



INSTALLATION INSTRUCTIONS FOR PART 95-8903B

APPLICATIONS

SUBARU LEGACY & OUTBACK 2010

(NON-NAVIGATION RADIOS ONLY)

95-8903B

KIT FEATURES

- DDIN radio provision
- Stacked ISO radio provision
- Painted scratch resistant matte black



KIT COMPONENTS

A) DDIN Trim plate B) DDIN Brackets

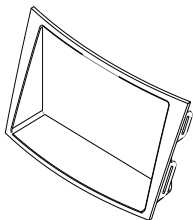

A

B

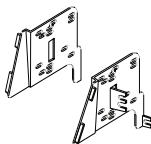

WIRING AND ANTENNA CONNECTIONS (Sold Separately)

Wiring Harness:

- 70-8901 Subaru Harness 1990-Up
- 70-7552 Nissan Harness 2007-Up

Antenna Adapter:

- 40-SB10 Subaru Antenna Adapter 2005-Up

TOOLS REQUIRED:

- Small Flat Blade Screwdriver
- Phillips Screwdriver
- Panel Removal Tool
- Socket Wrench

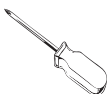

METRA. THE WORLD'S BEST KITS.™



1-800-221-0932



www.metraonline.com

© COPYRIGHT 2007-2009 METRA ELECTRONICS CORPORATION



TABLE OF CONTENTS

Dash Disassembly

- 2010 Subaru Legacy 1**
- 2010 Subaru Outback 1**

Kit Assembly

- Double DIN / Stacked ISO DIN Head Unit Provision. 2**

***Note:**

Refer also to the instructions included with the aftermarket radio.

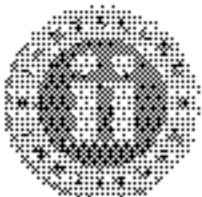

KNOWLEDGE IS POWER

Enhance your installation and subscription skills by enrolling in the most recognized and respected mobile electronics school in our industry. Log onto www.metradotcom.com or call 800-808-8787 for more information and take steps toward a better tomorrow.



Metra recommends MECP certified technicians.

2010 SUBARU LEGACY / OUTBACK

- 1** Disconnect the negative battery terminal to prevent an accidental short circuit.
- 2** Unclip and remove the radio trim panel including the a/c vents. (Figure A)
- 3** Remove (4) Phillips screws securing the factory radio.

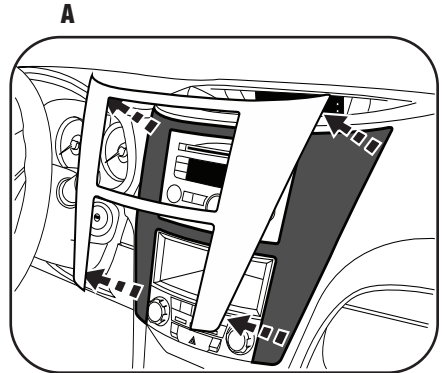



2010 SUBARU LEGACY / OUTBACK

DOUBLE DIN / STACKED ISO DIN HEAD UNIT PROVISIONS

- 1** Locate the factory wiring harness in the dash. Metra recommends using the proper mating adapter from Metra or AXCESS. Re-connect the negative battery terminal and test the unit for proper operation.
- 2** Attach the Double DIN brackets to the Double DIN trim plate. (Figure A)
- 3** Slide the Double DIN head unit or stacked ISO head units into the bracket/radio housing assembly and secure the Double DIN head unit or stacked ISO head units to the assembly using the screws supplied with the radio. (Figure B)
- 4** Reassemble dash in reverse order of disassembly.

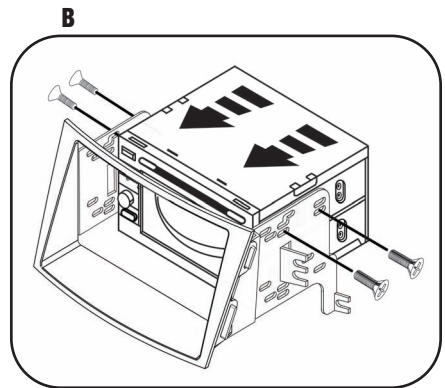
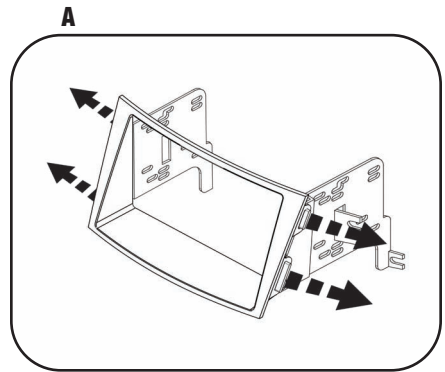



95-8903B

NOTES



95-8903B

NOTES



95-8903B

NOTES

95-8903B INSTRUCTIONS

METRA. THE WORLD'S BEST KITS.™



1-800-221-0932



www.metraonline.com

REV. 12/18/09 © COPYRIGHT 2003-2009 METRA ELECTRONICS CORPORATION INST95-8903B