



INSTALLATION INSTRUCTIONS FOR PART 95-3302

APPLICATIONS GM MULTI KIT (see models list inside)

95-3302

KIT FEATURES

- Double DIN Mount Radio Provision
- Stacked ISO Mount Radio Provision
- Painted To Match Factory Dash



KIT COMPONENTS

A) Double DIN Housing • B) Double DIN Brackets

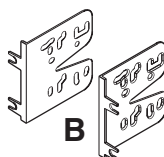
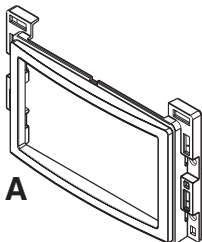

WIRING AND ANTENNA CONNECTIONS (Sold Separately)

Wiring Harness:

- See www.metraonline.com for specific interface applications

Antenna Adapter:

- 40-GM10 - GM antenna adapter 1988-up
- 40-CR10 - Chrysler antenna adapter 2002-up

TOOLS REQUIRED:

Small Flat Blade Screwdriver/ Panel Removal Tool

- Phillips Screwdriver • Socket Set • Cutting Tool

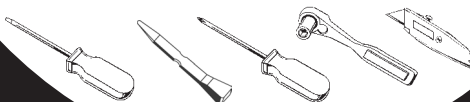

1-800-221-0932



www.metraonline.com

© COPYRIGHT 2004-2009 METRA ELECTRONICS CORPORATION



TABLE OF CONTENTS

Dash Disassembly

Chevrolet

- Cobalt 2005-20101
- Equinox 2005-2006 2
- HHR 2006-2010. 3
- Malibu 2004-20074,5
- Malibu 2008-20106

Saturn

- Aura 2007-2009 9
- Ion 2006-200710
- Sky 2006-200911
- Vue 2006-200712

Pontiac

- G5 2007-2009 1
- G6 2005-2009 7
- Solstice 2006-2009 8
- Torrent 2006..... 2

Kit Assembly

- Double DIN Mount Radio Provision 13
- Stacked ISO Mount Radio Provision 14

- Final Assembly 15

Note: (Cobalt and G5 2005-2006)
To retain Onstar use 99-3303 instead.

Note: (Malibu and G6 only)
•The Driver Information Center and radio are one unit. Removal of the radio will prohibit the vehicle owner from programming any of the features of the Driver Information Center. However once the features are programmed the vehicle will retain all the settings. An alternative kit 99-3303 includes a replacement driver information center with programming capabilities.

The 99-3303 does not allow for Double DIN installations.

• Refer also to the instructions included with the aftermarket radio.



KNOWLEDGE IS POWER

Enhance your installation and fabrication skills by enrolling in the most recognized and respected mobile electronics school in our industry.
 Log onto www.installerinstitute.com or call 800-354-6782 for more information and take steps toward a better tomorrow.

Chevrolet Cobalt 2005-2010/Pontiac G5 2007-09

1 Disconnect the negative battery terminal to prevent an accidental short circuit.

2 Unclip and remove trim panel from above glove box. **(Figure A)**

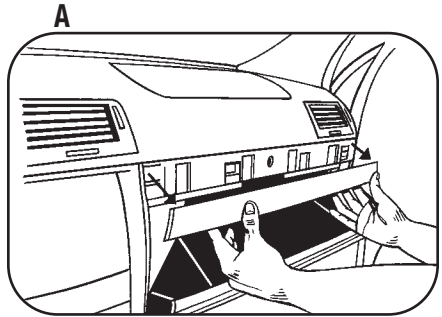

3 Unclip upper edge of panel below steering column and let hang. Not necessary to remove completely. **(Figure B)**

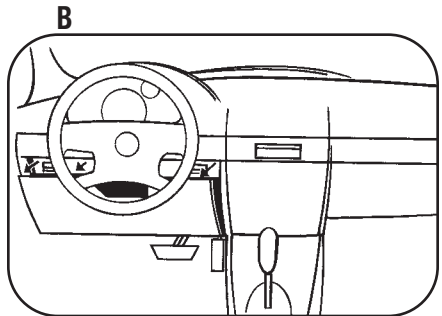

4 Unclip and remove small trim panel to right of ignition switch. **(Figure C)**

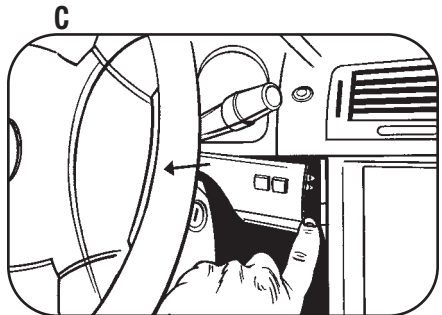

5 Unclip and remove trim panel surrounding radio and climate controls. **(Figure D)**

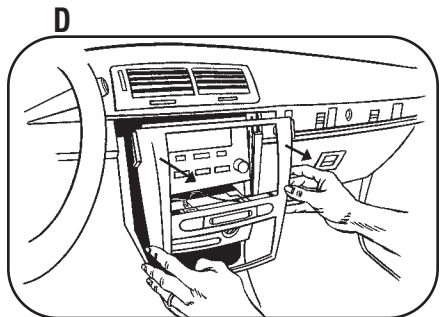

6 Remove (4) 9/32 screws securing radio. Unplug and remove the radio. **(Figure E)**

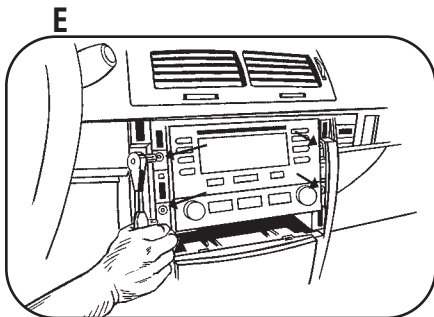

Continue to kit assembly.

Chevrolet Equinox 2005-2006
Pontiac Torrent 2006

- 1 Disconnect the negative battery terminal to prevent an accidental short circuit.
- 2 Unsnap panel below power window switch and remove. **Note:** *This allows you to unplug the window switch easier.* **(Figure A)**
- 3 Unsnap and remove entire panel surrounding radio and shifter. **(Figure B)**
- 4 Remove (4) 9/32 screws securing radio. Unplug and remove the radio. **(Figure C)**

Continue to kit assembly.

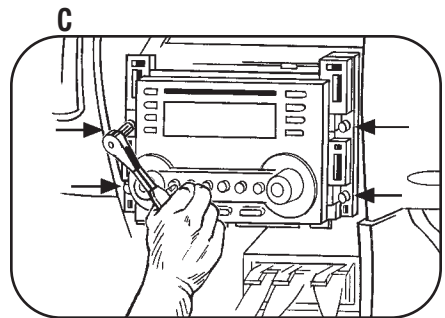
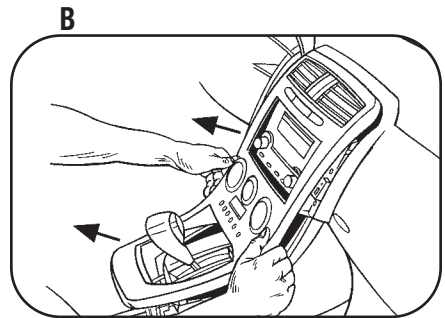
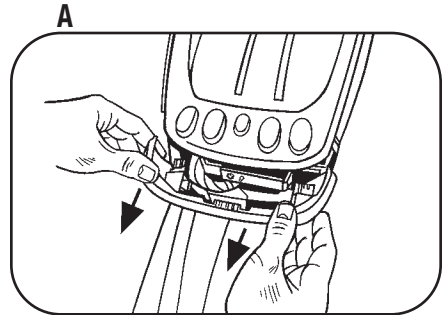

Chevrolet HHR 2006-2010

- 1** Disconnect the negative battery terminal to prevent an accidental short circuit.
- 2** Unclip and remove entire panel surrounding radio and a/c controls including the a/c vents. **(Figure A)**
- 3** Remove (8) 9/32" screws securing radio and a/c control to remove radio. **(Figure B)**

Continue to kit assembly.

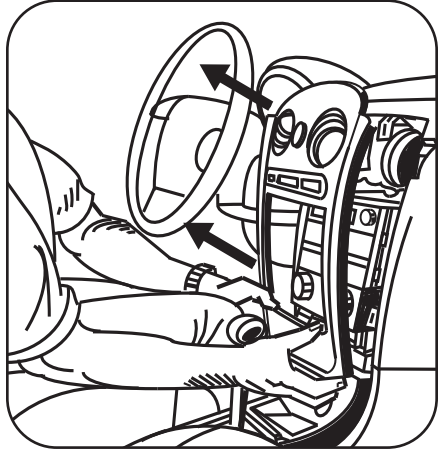
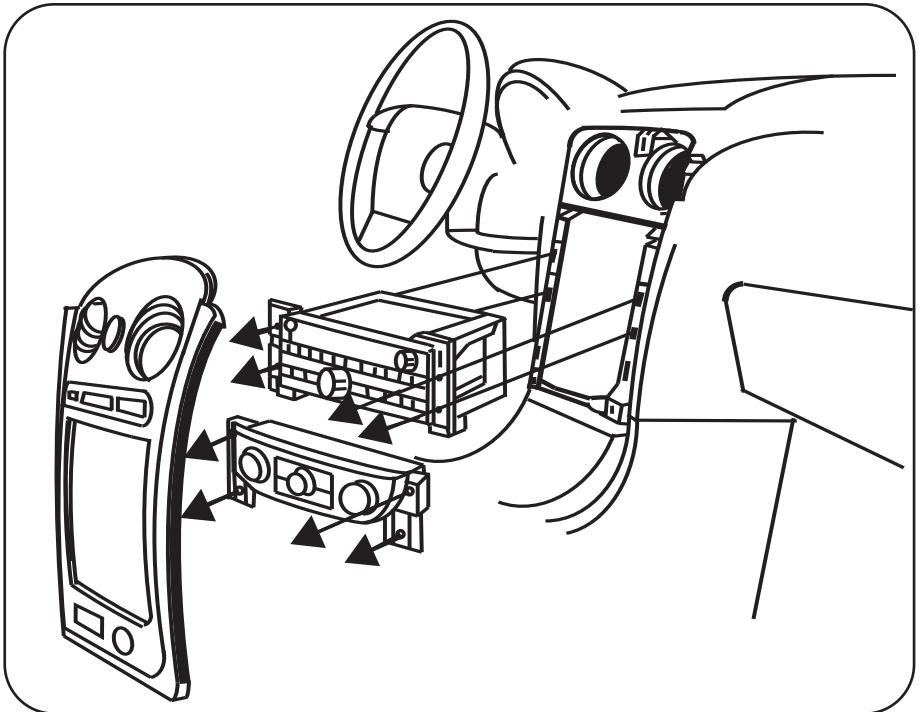
A

B

Chevrolet Malibu 2004-2007

1 Disconnect the negative battery terminal to prevent an accidental short circuit.

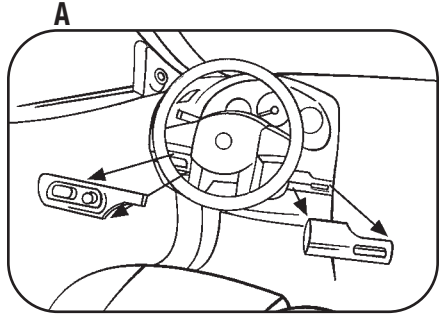
2 Unclip and remove wood grain/painted trim pieces from both sides of steering wheel. **(Figure A)**



3 Unclip and remove side panel from driver's side of dash with door open and remove (2) 7 MM screws. **(Figure B)**

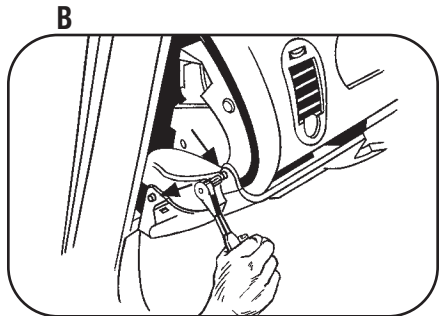

4 Remove (2) 7 MM screws from bottom edge of panel below steering wheel, unclip panel and let hang. It is not necessary to completely remove panel. **(Figure C)**

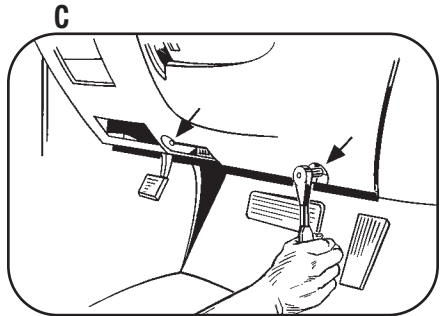

5 Unclip and remove wood grain/painted trim piece from above glove box. **(Figure D)**

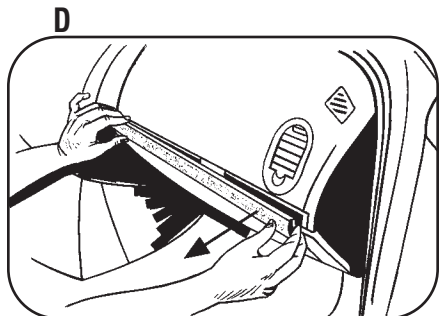

Chevrolet Malibu 2004-2007

- 6** Unclip and remove side panel from passenger side of dash with door open and remove (2) 7 MM screws from behind panel. **(Figure E)**
- 7** Remove (2) 7 MM screws from bottom of glove box then open box and squeeze sides together to open further and remove the remaining (4) 7MM screws. Unclip the black vent cover under the glove box then unclip and remove entire glove box assembly. **(Figure F)**
- 8** Unclip and remove trim panel surrounding radio and climate controls. **(Figure G)**
- 9** Remove (4) 7 MM screws securing the radio and (2) 7 MM screws securing the climate control. Unplug and remove the radio. **(Figure H)**

Continue to kit assembly.

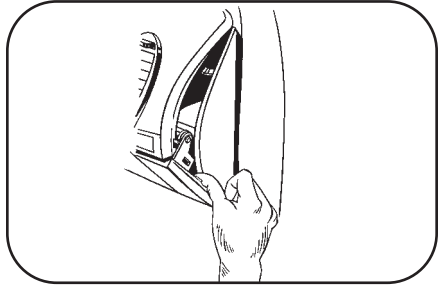
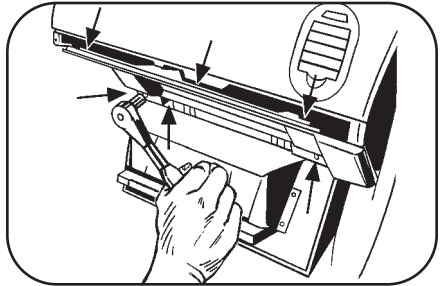
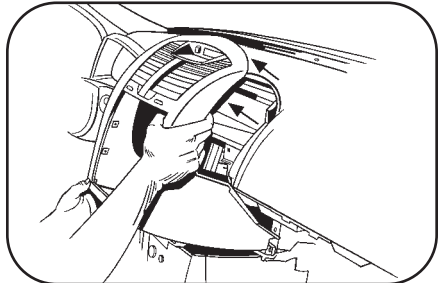
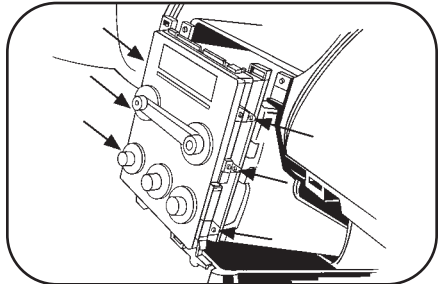
E

F

G

H

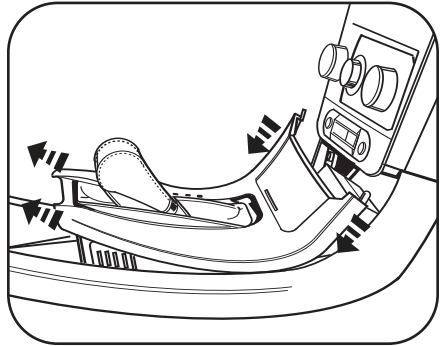
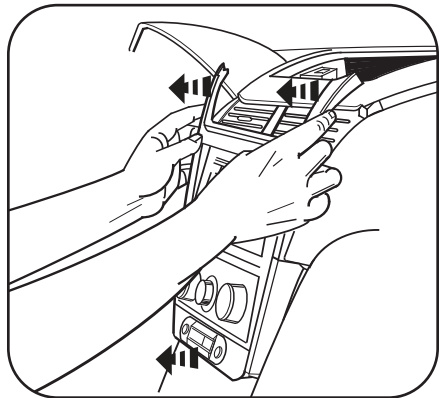
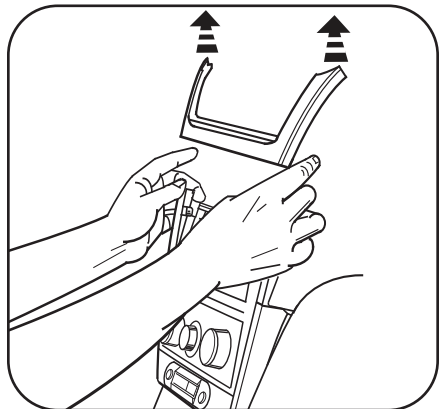
Chevrolet Malibu 2008-2010

- 1 Disconnect the negative battery terminal to prevent an accidental short circuit.
- 2 Unsnap and remove shifter trim.
Note – start around shifter and be sure to pull down before back because this panel slides up under the radio/climate panels. (Figure A)
- 3 Remove (2) 8 mm screws from bottom of radio/climate panel.
- 4 Unsnap and remove the climate/radio panel and upper vent trim panel together. (They can be separated after removal) (Figure B,C)
- 5 Remove (6) 8 mm screws from radio and climate controls.

Continue to kit assembly.

A

B

C

Pontiac G6 2005-2009

- 1 Disconnect the negative battery terminal to prevent an accidental short circuit.
- 2 Open glove box and remove (6) screws from outer edge then unclip and remove box. **(Figure A)**
- 3 Remove (4) screws from panel below steering column. Unclip and remove panel. **(Figure B)**
- 4 Unclip and remove center panel surrounding radio and A/C controls. **(Figure C)**
- 5 Remove (4) screws securing the radio. Unplug and remove the radio. **(Figure D)**

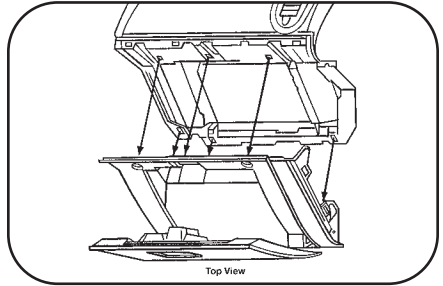
Continue to kit assembly.

A



B

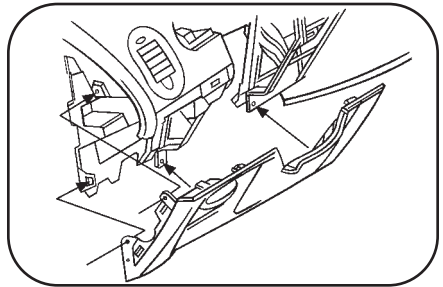

C

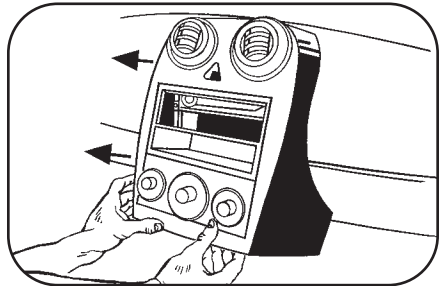

D

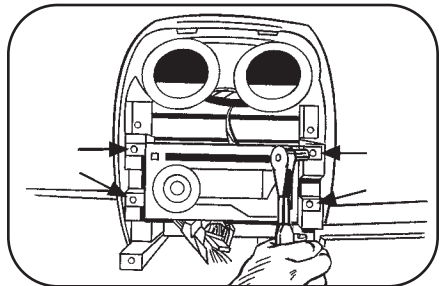

Pontiac Solstice 2006-2009

1 Disconnect the negative battery terminal to prevent an accidental short circuit.

2 Manual transmission:

A. Lift up the lower edge of the instrument panel cluster trim plate enough to reach underneath and release the shift boot trim ring retaining tabs. **(Figure A)**

B. Lift up on the shift boot and loosen the setscrew to release the shift lever. **(Figure B)**

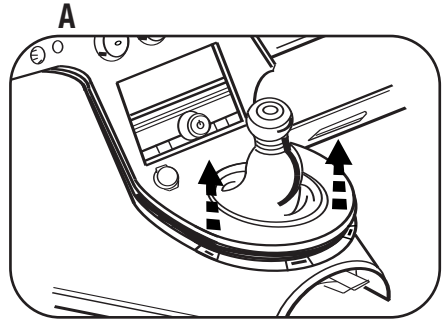

2 Automatic transmission:

A. Unclip and remove shifter trim ring. **(Figure C)**

3 Unclip and remove passenger assist handle trim panel. **(Figure D)**

4 Remove (2) bolts securing the passenger assist handle and remove handle. **(Figure D)**

5 Unclip and remove dash trim panel.

6 Remove (4) screws securing the radio. Unplug and remove the radio.

Continue to kit assembly.

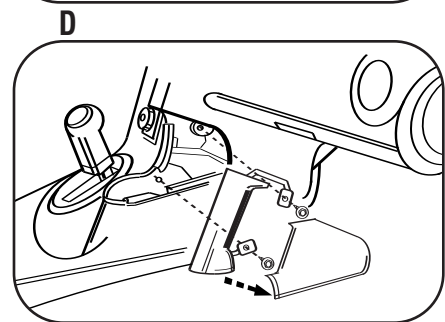
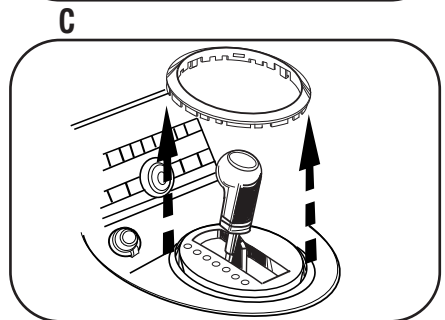
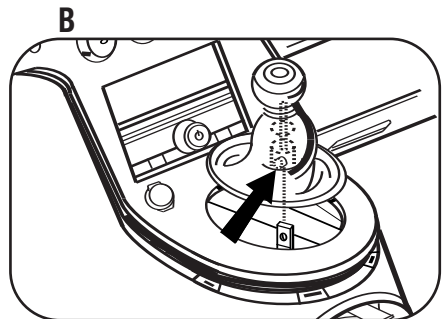

Saturn Aura 2007-2009

- 1 Disconnect the negative battery terminal to prevent an accidental short circuit.
- 2 Unclip and remove shifter trim ring. **(Figure A)**
- 3 Unclip and remove the center console trim panel, then remove (2) screws from bottom edge of dash trim panel. **(Figure B)**
- 4 Unclip and remove the key switch trim ring, then unclip and remove dash trim panel. **(Figure C)**
- 5 Remove (2) screws securing the climate controls.
- 6 Remove (4) screws securing the radio. Unplug and remove the radio.

Continue to kit assembly.

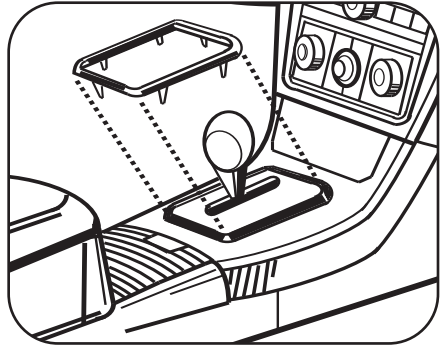
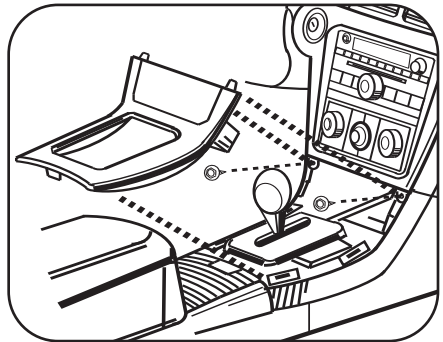
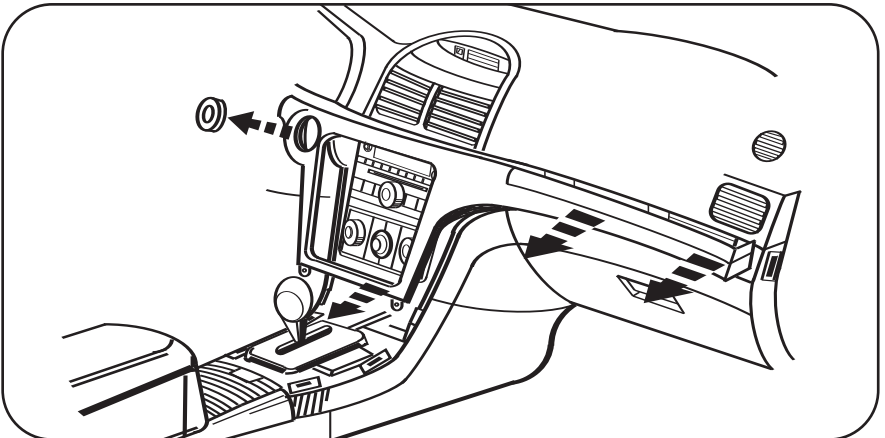
A

B

C

Saturn Ion 2006-2007

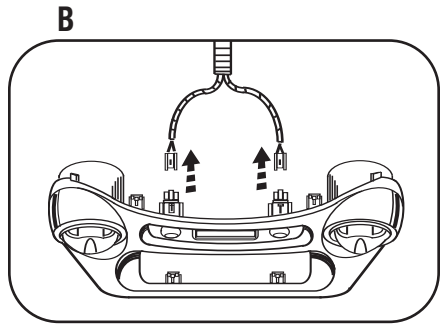
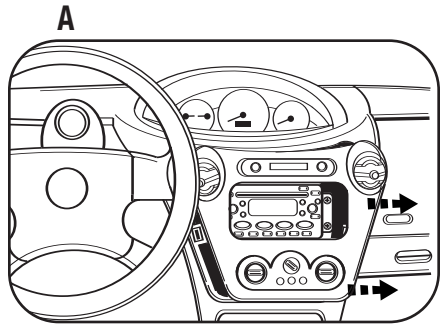
- 1** Disconnect the negative battery terminal to prevent an accidental short circuit.
- 2** Unclip radio trim panel. **(Figure A)**
Unplug connectors from trim panel and remove panel. **(Figure B)**
- 3** Remove (4) screws securing the radio. Unplug and remove the radio.

Continue to kit assembly.



Saturn Sky 2006-2009

- 1 Disconnect the negative battery terminal to prevent an accidental short circuit.
- 2 Unclip and remove side panel from driver's side of dash with door open and remove (2) 7 MM screws. **(Figure A)**
- 3 Remove (2) 7 MM screws from bottom edge of panel below steering wheel, unclip panel and remove panel.
- 4 Unclip and remove side panel from passenger side of dash with door open and remove (2) 7 MM screws from behind panel. **(Figure B)**
- 5 Open the glove box and disconnect the glove box dampener from the glove box assembly. Squeeze sides together to open further. **(Figure C)**
- 6 Remove (2) bolt covers from top edge of glove box frame. **(Figure C)**
- 7 Remove (5) bolts from glove box frame and remove frame. **(Figure C)**
- 8 Unsnap and remove climate control trim panel. **(Figure D)**
- 9 Remove (1) screw from lower left corner of radio trim panel and unplug connectors to remove panel. **(Figure D)**
- 10 Remove (4) screws securing the radio. Unplug and remove the radio.

Continue to kit assembly.

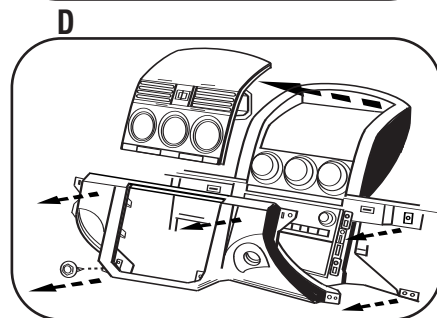
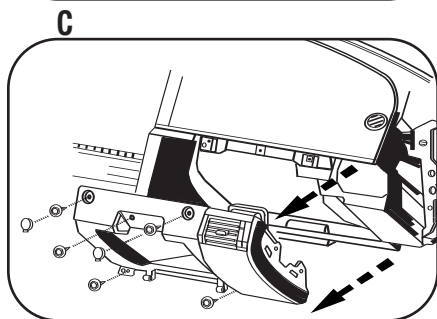
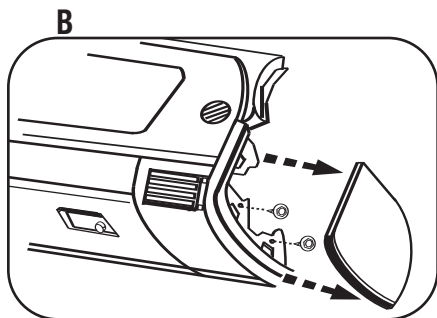
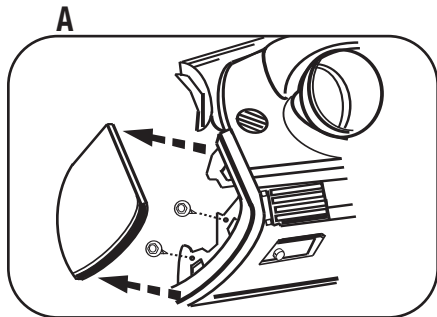

Saturn Vue 2006-2007

- 1** Disconnect the negative battery terminal to prevent an accidental short circuit.
- 2** Grasp the front edge of the shifter trim panel and pull outward and upward. (Figure A)
- 3** Squeeze the locking tabs located at the front edge of the shifter trim panel together to release the front edge of the panel from the center console. (Figure B)
- 4** Pull upward on the panel to release the remaining clips, and remove trim panel.
- 5** Remove (4) screws securing storage pocket and remove pocket. (Figure C)
- 6** Unclip and remove center dash trim panel. (Figure D)
- 7** Remove (4) screws securing the radio. Unplug and remove the radio.

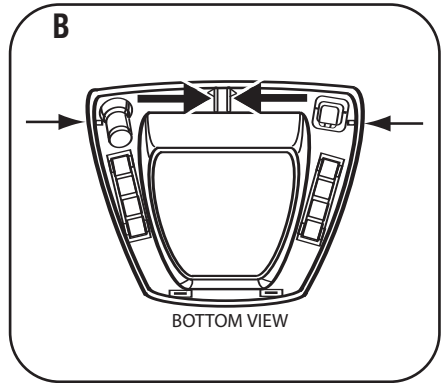
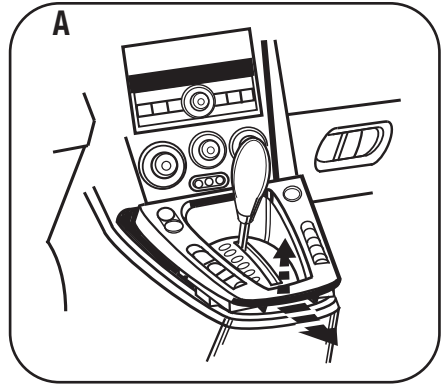

Continue to kit assembly.

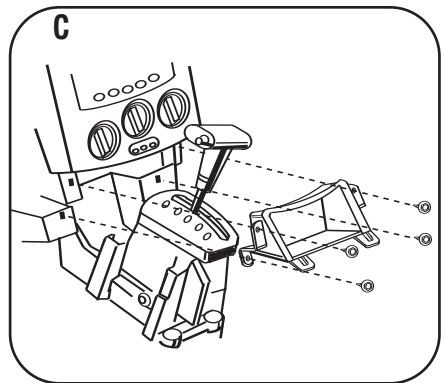
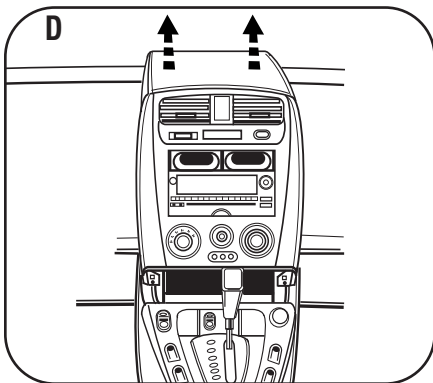

DOUBLE DIN MOUNT RADIO PROVISION

**Note: Refer also to the instructions included with the aftermarket radio.*

- 1 Slide the appropriate bracket into the trim plate aligning the holes in the trim plate to the clips on the bracket. (Figure A)
- 2 Slide the DDIN radio unit into the trim plate bracket assembly and secure the unit to the kit using the screws supplied with the head unit. (Figure B)
- 3 **Aura, Cobalt, G5, HHR, Sky and Vue only:**
Cut and remove top mounting tabs on each side of the Radio Housing. (Figure C)

Continue to final assembly.

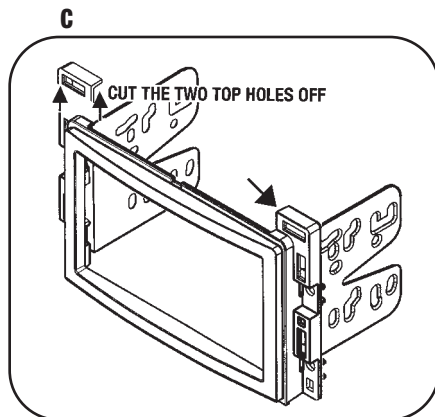
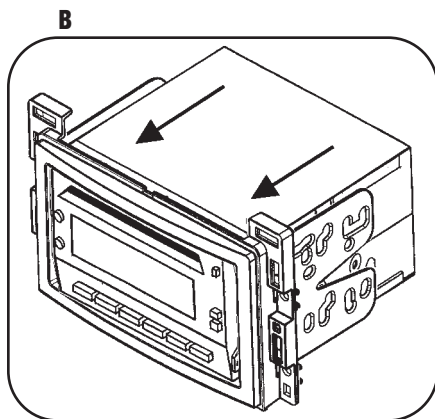
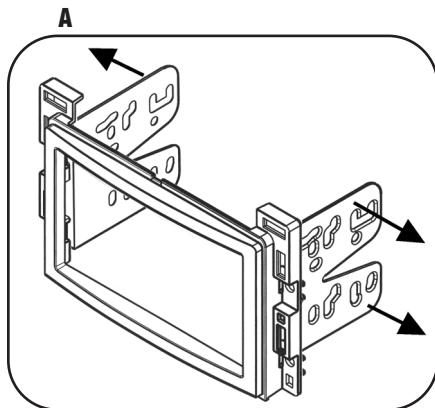

STACKED ISO MOUNT RADIO PROVISION

**Note: Refer also to the instructions included with the aftermarket radio.*

- 1 Slide the appropriate bracket into the trim plate aligning the holes in the trim plate to the clips on the bracket. (Figure A)
- 2 Slide the stacked ISO DIN units into the trim plate bracket assembly and secure the units to the kit using the screws supplied with the head units. (Figure B)
- 3 **Aura, Cobalt, G5, HHR, Sky and Vue only:**
Cut and remove top mounting tabs on each side of the Radio Housing.

Continue to final assembly.

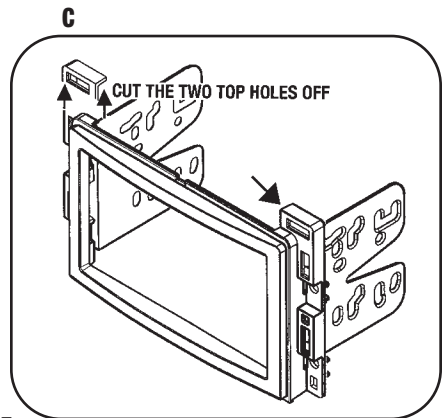
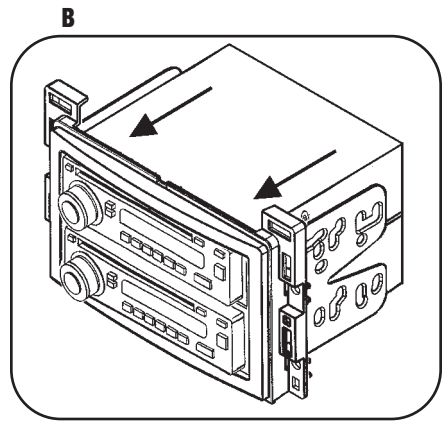
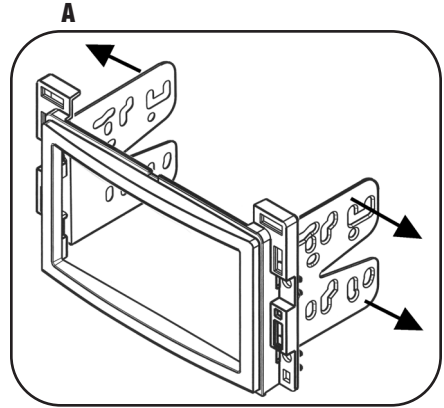

FINAL ASSEMBLY

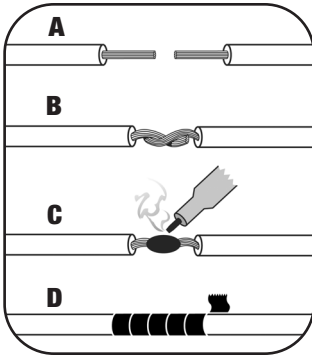

(A) Strip wire ends back 1/2"

B) Twist ends together

C) Solder

D) Tape

- 1** Locate the factory wiring harness in the dash. Metra recommends using the proper mating adapter and making connections as shown. (Isolate and individually tape off the ends of any unused wires to prevent electrical short circuit.)
- 2** Re-connect the negative battery terminal and test the unit for proper operation.
- 3** Reassemble radio and dash assemblies in reverse order of disassembly.

FINAL WIRING CONNECTIONS

Make wiring connections using the EIA color code chart shown below and the instructions included with the head unit. Metra recommends making connections as shown below; Strip, Splice, Solder, Tape. Isolate and individually tape off ends of any unused wires to prevent electrical short circuit.

METRA / EIA WIRING CODE

12V Ignition / Acc. Red	Right Front (+) Gray
12V Batt / Memory Yellow	Right Front (-) Gray / Black
Ground Black*	Left Front (+) White
Power Antenna Blue	Left Front (-) White / Black
Amp Turn-On Blue / White	Right Rear (+) Violet
Amp Ground Black / White	Right Rear (-) Violet / Black
Illumination Orange	Left Rear (+) Green
Dimmer Orange / White	Left Rear (-) Green / Black

***NOTE:** When a Black wire is not present, ground radio to vehicle chassis.
All colors may not be present on all leads due to manufacturer's specifications.

95-3302 INSTRUCTIONS



1-800-221-0932



www.metraonline.com

REV. 05/03/10 © COPYRIGHT 2001-2010 METRA ELECTRONICS CORPORATION INST95-3302