

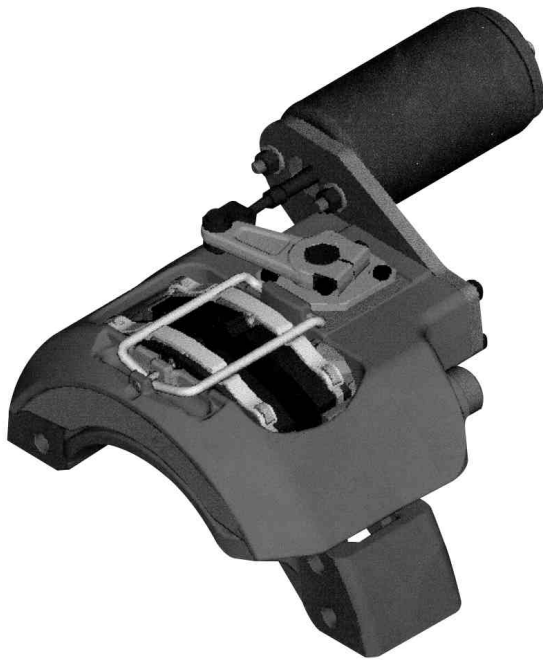


MERITOR™
A Heritage of Rockwell Technology

Issued 10-99
\$2.50

DXP 195 Air Release and Hydraulic Release Parking Disc Brakes

Maintenance Manual No. MM-9902



This publication provides maintenance and service procedures for Meritor's DXP 195 air release and hydraulic release parking disc brakes. The information contained in this publication was current at the time of printing and is subject to revision without notice or liability.

1. You must understand all procedures and instructions before you begin maintenance and service procedures.
2. You must follow your company's maintenance and service guidelines.
3. You must use special tools, when required, to avoid serious personal injury and damage to components.

Meritor uses the following notations to warn the user of possible safety problems and to provide information that will prevent damage to equipment and components.



WARNING

A WARNING indicates a procedure that you must follow exactly to avoid serious personal injury.

NOTE: A **NOTE** indicates an operation, procedure or instruction that is important for proper service. A **NOTE** can also supply information that can help to make service quicker and easier.



CAUTION

A CAUTION indicates a procedure that you must follow exactly to avoid damaging equipment or components. Serious personal injury can also occur.



This symbol indicates that fasteners must be tightened to a specific torque.

Visit Our Web Site

Visit the Technical Library section of www.meritorauto.com for additional product and service information on Meritor's Heavy Vehicle Systems component lineup.


Technical Electronic Library on CD

The CD includes product and service information on Meritor's component lineup. \$20. Order TP-9853.

How to Order

Call Meritor's Customer Service Center at 800-535-5560.



 **Asbestos and Non-Asbestos Fibers Warnings** 1

Section 1: Exploded View.....2

Section 2: Introduction

 Description.....4

 Identification5

Section 3: Disassembly

 Remove the Linings.....6

 Remove the Caliper Assembly7

Section 4: Assembly

 Install the Caliper Assembly8

 Install the Linings

 Adjust the Initial Caliper Clearance9

Section 5: Maintenance

 Hydraulic Fluid10

 Inspection Schedule

 Check the Adjusted Chamber Stroke Length

 Inspect the Brake Components11

 Cleaning13

Section 6: Diagnostics

 DXP 195 Air Release and Hydraulic Release Parking Disc Brakes15

Section 7: Specifications

 Torque Specifications16



ASBESTOS FIBERS WARNING

The following procedures for servicing brakes are recommended to reduce exposure to asbestos fiber dust, a cancer and lung disease hazard. Material Safety Data Sheets are available from Meritor.

Hazard Summary

Because some brake linings contain asbestos, workers who service brakes must understand the potential hazards of asbestos and precautions for reducing risks. Exposure to airborne asbestos dust can cause serious and possibly fatal diseases, including asbestosis (a chronic lung disease) and cancer, principally lung cancer and mesothelioma (a cancer of the lining of the chest or abdominal cavities). Some studies show that the risk of lung cancer among persons who smoke and who are exposed to asbestos is much greater than the risk for non-smokers. Symptoms of these diseases may not become apparent for 15, 20 or more years after the first exposure to asbestos.

Accordingly, workers must use caution to avoid creating and breathing dust when servicing brakes. Specific recommended work practices for reducing exposure to asbestos dust follow. Consult your employer for more details.

Recommended Work Practices

1. **Separate Work Areas.** Whenever feasible, service brakes in a separate area away from other operations to reduce risks to unprotected persons. OSHA has set a maximum allowable level of exposure for asbestos of 0.1 f/cc as an 8-hour time-weighted average and 1.0 f/cc averaged over a 30-minute period. Scientists disagree, however, to what extent adherence to the maximum allowable exposure levels will eliminate the risk of disease that can result from inhaling asbestos dust. OSHA requires that the following sign be posted at the entrance to areas where exposures exceed either of the maximum allowable levels:

**DANGER: ASBESTOS
CANCER AND LUNG DISEASE HAZARD
AUTHORIZED PERSONNEL ONLY
RESPIRATORS AND PROTECTIVE CLOTHING
ARE REQUIRED IN THIS AREA.**

2. **Respiratory Protection.** Wear a respirator equipped with a high-efficiency (HEPA) filter approved by NIOSH or MSHA for use with asbestos at all times when servicing brakes, beginning with the removal of the wheels.
3. **Procedures for Servicing Brakes.**
 - a. Enclose the brake assembly within a negative pressure enclosure. The enclosure should be equipped with a HEPA vacuum and worker arm sleeves. With the enclosure in place, use the HEPA vacuum to loosen and vacuum residue from the brake parts.
 - b. As an alternative procedure, use a catch basin with water and a biodegradable, non-phosphate, water-based detergent to wash the brake drum or rotor and other brake parts. The solution should be applied with low pressure to prevent dust from becoming airborne. Allow the solution to flow between the brake drum and the brake support or the brake rotor and caliper. The wheel hub and brake assembly components should be thoroughly wetted to suppress dust before the brake shoes or brake pads are removed. Wipe the brake parts clean with a cloth.
 - c. If an enclosed vacuum system or brake washing equipment is not available, employers may adopt their own written procedures for servicing brakes, provided that the exposure levels associated with the employer's procedures do not exceed the levels associated with the enclosed vacuum system or brake washing equipment. Consult OSHA regulations for more details.
 - d. Wear a respirator equipped with a HEPA filter approved by NIOSH or MSHA for use with asbestos when grinding or machining brake linings. In addition, do such work in an area with a local exhaust ventilation system equipped with a HEPA filter.
 - e. **NEVER** use compressed air by itself, dry brushing, or a vacuum not equipped with a HEPA filter when cleaning brake parts or assemblies. **NEVER** use carcinogenic solvents, flammable solvents, or solvents that can damage brake components as wetting agents.
4. **Cleaning Work Areas.** Clean work areas with a vacuum equipped with a HEPA filter or by wet wiping. **NEVER** use compressed air or dry sweeping to clean work areas. When you empty vacuum cleaners and handle used rags, wear a respirator equipped with a HEPA filter approved by NIOSH or MSHA for use with asbestos. When you replace a HEPA filter, wet the filter with a fine mist of water and dispose of the used filter with care.
5. **Worker Clean-Up.** After servicing brakes, wash your hands before you eat, drink or smoke. Shower after work. Do not wear work clothes home. Use a vacuum equipped with a HEPA filter to vacuum work clothes after they are worn. Launder them separately. Do not shake or use compressed air to remove dust from work clothes.
6. **Waste Disposal.** Dispose of discarded linings, used rags, cloths and HEPA filters with care, such as in sealed plastic bags. Consult applicable EPA, state and local regulations on waste disposal.

Regulatory Guidance

References to OSHA, NIOSH, MSHA, and EPA, which are regulatory agencies in the United States, are made to provide further guidance to employers and workers employed within the United States. Employers and workers employed outside of the United States should consult the regulations that apply to them for further guidance.



NON-ASBESTOS FIBERS WARNING

The following procedures for servicing brakes are recommended to reduce exposure to non-asbestos fiber dust, a cancer and lung disease hazard. Material Safety Data Sheets are available from Meritor.

Hazard Summary

Most recently manufactured brake linings do not contain asbestos fibers. These brake linings may contain one or more of a variety of ingredients, including glass fibers, mineral wool, aramid fibers, ceramic fibers and silica that can present health risks if inhaled. Scientists disagree on the extent of the risks from exposure to these substances. Nonetheless, exposure to silica dust can cause silicosis, a non-cancerous lung disease. Silicosis gradually reduces lung capacity and efficiency and can result in serious breathing difficulty. Some scientists believe other types of non-asbestos fibers, when inhaled, can cause similar diseases of the lung. In addition, silica dust and ceramic fiber dust are known to the State of California to cause lung cancer. U.S. and international agencies have also determined that dust from mineral wool, ceramic fibers and silica are potential causes of cancer.

Accordingly, workers must use caution to avoid creating and breathing dust when servicing brakes. Specific recommended work practices for reducing exposure to non-asbestos dust follow. Consult your employer for more details.

Recommended Work Practices

1. **Separate Work Areas.** Whenever feasible, service brakes in a separate area away from other operations to reduce risks to unprotected persons.
2. **Respiratory Protection.** OSHA has set a maximum allowable level of exposure for silica of 0.1 mg/m³ as an 8-hour time-weighted average. Some manufacturers of non-asbestos brake linings recommend that exposures to other ingredients found in non-asbestos brake linings be kept below 1.0 f/cc as an 8-hour time-weighted average. Scientists disagree, however, to what extent adherence to these maximum allowable exposure levels will eliminate the risk of disease that can result from inhaling non-asbestos dust. Therefore, wear respiratory protection at all times during brake servicing, beginning with the removal of the wheels. Wear a respirator equipped with a high-efficiency (HEPA) filter approved by NIOSH or MSHA, if the exposure levels may exceed OSHA or manufacturers' recommended maximum levels. Even when exposures are expected to be within the maximum allowable levels, wearing such a respirator at all times during brake servicing will help minimize exposure.
3. **Procedures for Servicing Brakes.**
 - a. Enclose the brake assembly within a negative pressure enclosure. The enclosure should be equipped with a HEPA vacuum and worker arm sleeves. With the enclosure in place, use the HEPA vacuum to loosen and vacuum residue from the brake parts.
 - b. As an alternative procedure, use a catch basin with water and a biodegradable, non-phosphate, water-based detergent to wash the brake drum or rotor and other brake parts. The solution should be applied with low pressure to prevent dust from becoming airborne. Allow the solution to flow between the brake drum and the brake support or the brake rotor and caliper. The wheel hub and brake assembly components should be thoroughly wetted to suppress dust before the brake shoes or brake pads are removed. Wipe the brake parts clean with a cloth.
 - c. If an enclosed vacuum system or brake washing equipment is not available, carefully clean the brake parts in the open air. Wet the parts with a solution applied with a pump-spray bottle that creates a fine mist. Use a solution containing water, and, if available, a biodegradable, non-phosphate, water-based detergent. The wheel hub and brake assembly components should be thoroughly wetted to suppress dust before the brake shoes or brake pads are removed. Wipe the brake parts clean with a cloth.
 - d. Wear a respirator equipped with a HEPA filter approved by NIOSH or MSHA when grinding or machining brake linings. In addition, do such work in an area with a local exhaust ventilation system equipped with a HEPA filter.
 - e. **NEVER** use compressed air by itself, dry brushing, or a vacuum not equipped with a HEPA filter when cleaning brake parts or assemblies. **NEVER** use carcinogenic solvents, flammable solvents, or solvents that can damage brake components as wetting agents.
4. **Cleaning Work Areas.** Clean work areas with a vacuum equipped with a HEPA filter or by wet wiping. **NEVER** use compressed air or dry sweeping to clean work areas. When you empty vacuum cleaners and handle used rags, wear a respirator equipped with a HEPA filter approved by NIOSH or MSHA, to minimize exposure. When you replace a HEPA filter, wet the filter with a fine mist of water and dispose of the used filter with care.
5. **Worker Clean-Up.** After servicing brakes, wash your hands before you eat, drink or smoke. Shower after work. Do not wear work clothes home. Use a vacuum equipped with a HEPA filter to vacuum work clothes after they are worn. Launder them separately. Do not shake or use compressed air to remove dust from work clothes.
6. **Waste Disposal.** Dispose of discarded linings, used rags, cloths and HEPA filters with care, such as in sealed plastic bags. Consult applicable EPA, state and local regulations on waste disposal.

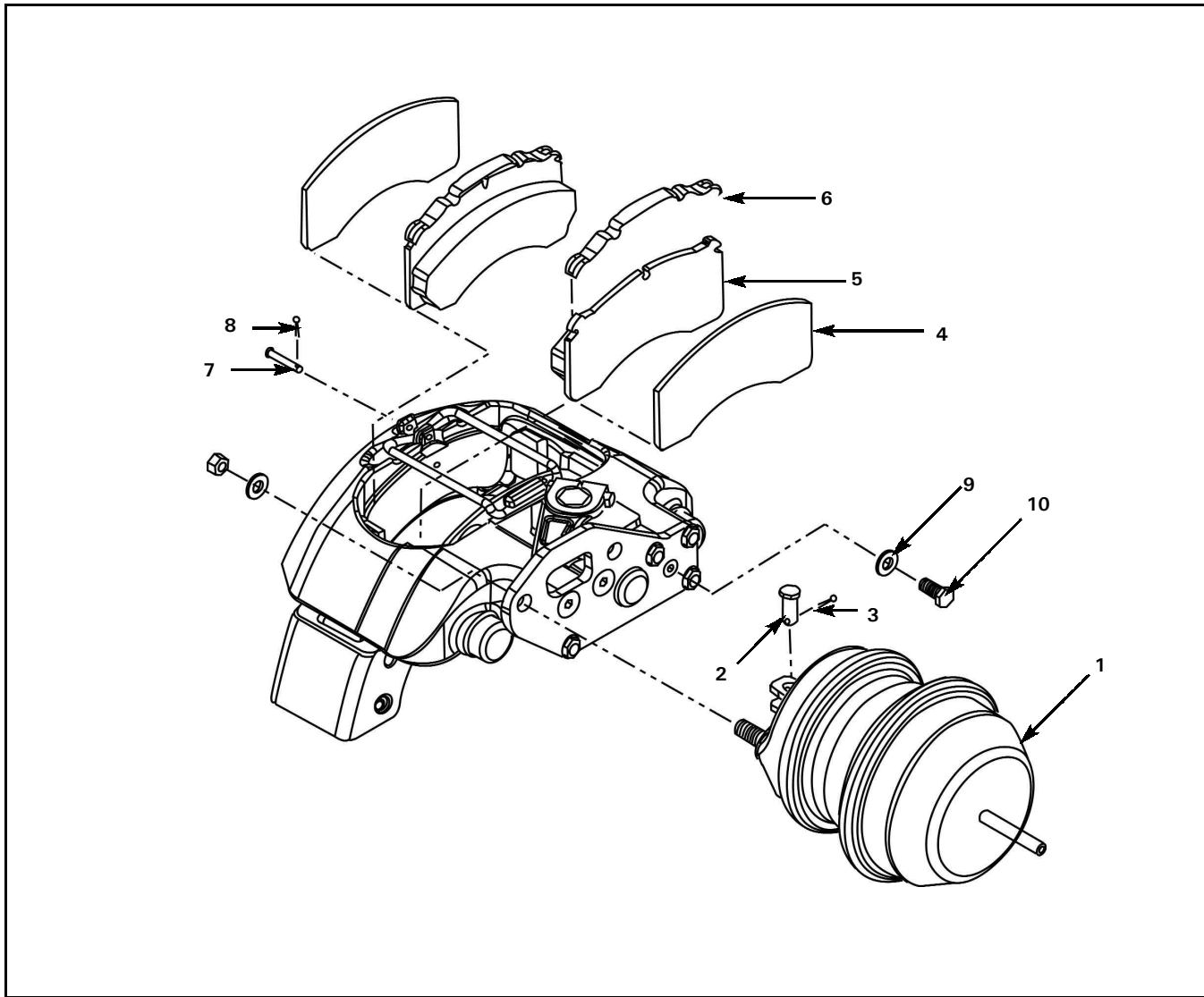
Regulatory Guidance

References to OSHA, NIOSH, MSHA, and EPA, which are regulatory agencies in the United States, are made to provide further guidance to employers and workers employed within the United States. Employers and workers employed outside of the United States should consult the regulations that apply to them for further guidance.

Section 1 Exploded View



Spring-Applied Air Release Brake (Left-Hand Brake)

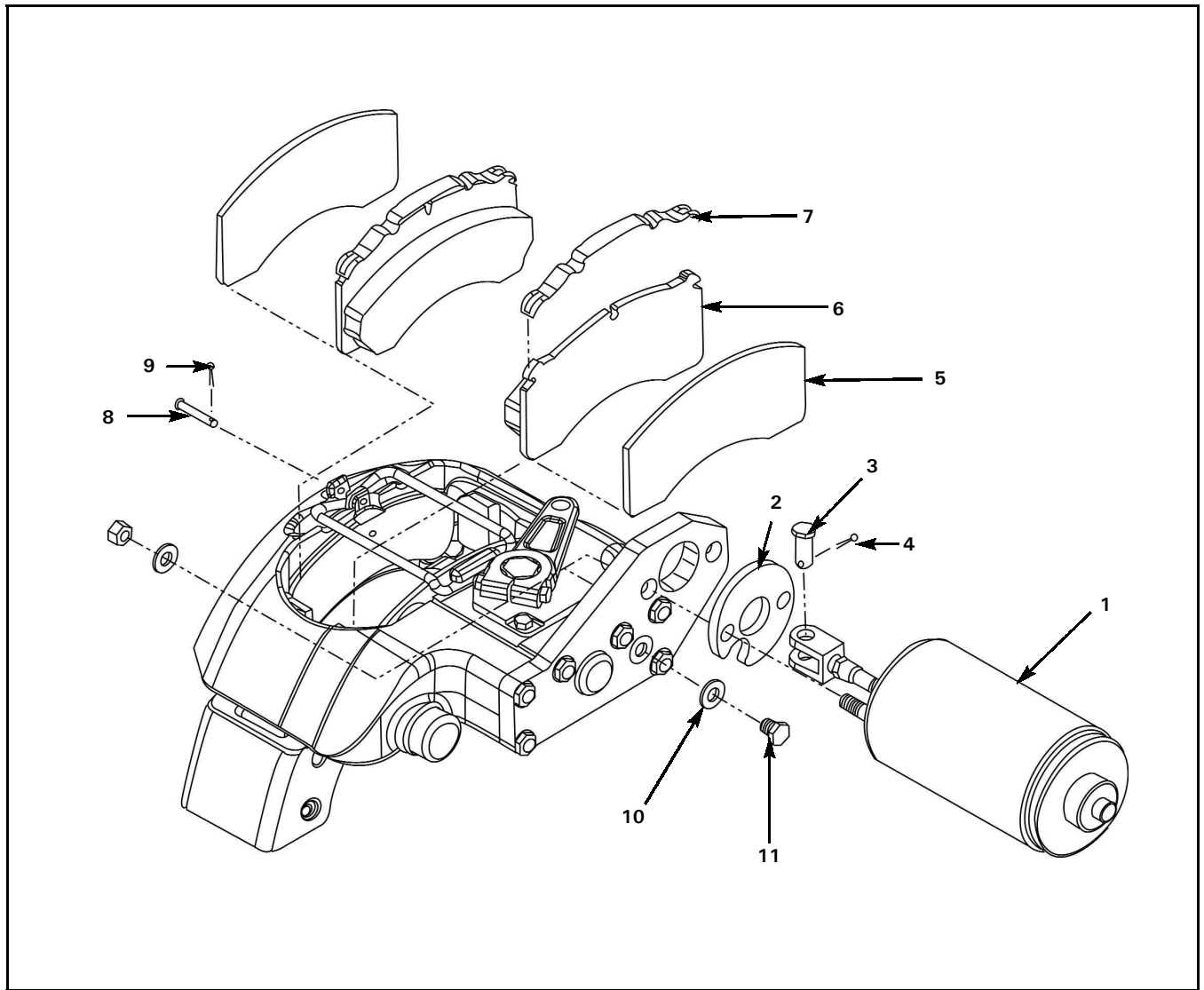


Item	Description	Sequence Number *
1	Chamber	00100
2	Pin	00110
3	Cotter Pin	00120
4	Spacer	00130
5	Lining Assembly	00140

Item	Description	Sequence Number *
6	Spring	00150
7	Retaining Pin	00160
8	Cotter Pin	00170
9	Washer	00180
10	Adjuster Plug	00190

* Sequence numbers appear in the bill of material available from the equipment manufacturer.

Spring-Applied Hydraulic Release Brake (Left-Hand Brake)



Item	Description	Sequence Number *
1	Chamber	00100
2	Spacer	00105
3	Pin	00110
4	Cotter Pin	00120
5	Spacer	00130
6	Lining Assembly	00140

Item	Description	Sequence Number *
7	Spring	00150
8	Retaining Pin	00160
9	Cotter Pin	00170
10	Washer	00180
11	Adjuster Plug	00190

* Sequence numbers appear in the bill of material available from the equipment manufacturer.

Section 2

Introduction



Description

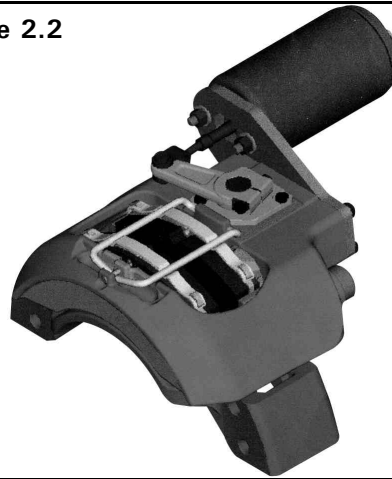
The DXP 195 dry disc parking brake fits a 14.88-16.54-inch (378-420 mm) disc range and can be packaged as a driveline, wheel end or axle-mounted park brake. It is designed for use in off-highway haulers, mining vehicles, front-end loaders and various stationary machinery.

- The brake features a lightweight single-piece cast caliper, supported on twin slide pins, which is fixed to a "universal" mounting saddle.
 - Brake pads are located in the saddle and are easily accessible for inspection or replacement.
 - The actuation device, with air or hydraulic release, can be placed in multiple positions to clear other components for easy packaging.
 - Additionally, the brake can mount in any position around the disc.
- Figures 2.1 and 2.2.**

Figure 2.1

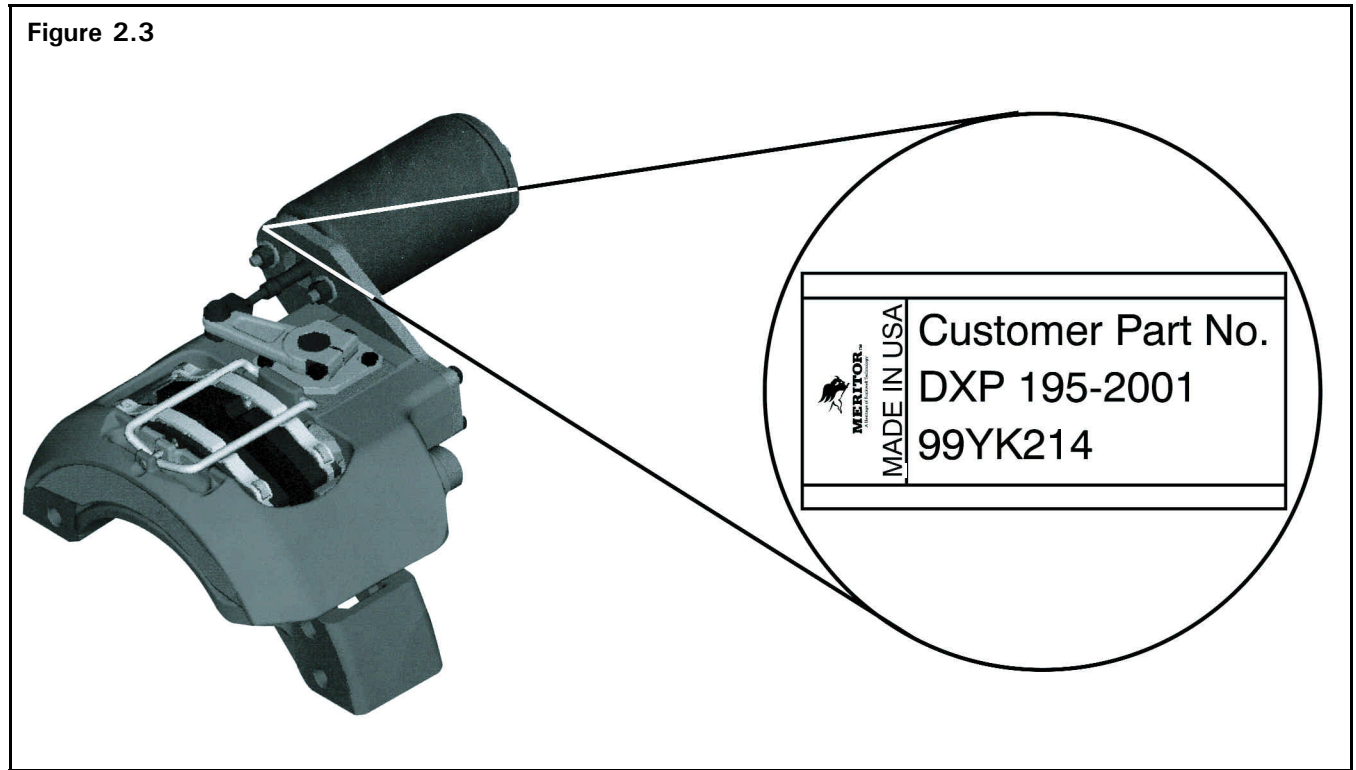


Figure 2.2



Identification

To identify the DXP 195 assembly, refer to the tag located on the chamber bracket. **Figure 2.3.**



Section 3 Disassembly



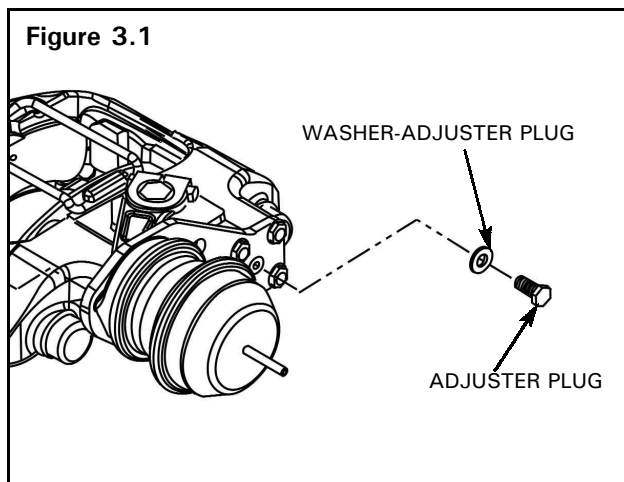
Remove the Linings

WARNING

To prevent serious eye injury, always wear safe eye protection when you perform vehicle maintenance or service.

Do not work under a vehicle supported only by jacks. Jacks can slip or fall over and cause serious personal injury. Support the vehicle with safety stands.

1. Block the wheels of the vehicle to prevent the vehicle from moving.
2. If necessary, raise the vehicle. Support the vehicle with safety stands.
3. Remove the adjuster plug and washer from the chamber bracket. **Figure 3.1.**



CAUTION

Use an Allen wrench to manually adjust and de-adjust the brakes. Do not use an air gun to adjust or de-adjust the brakes. Damage to components can result.

Stop turning the Allen wrench when you feel resistance. Do not continue to turn the Allen wrench beyond the resistance point. Damage to components can result.

NOTE: When you de-adjust the brake (increase disc clearance), you will hear a "clicking" sound and feel a "pulsing" sensation during the adjustment.

4. Use a 6 mm Allen wrench to de-adjust the brake as specified on the brake caliper and in **Table A** below. Stop turning the Allen wrench when you feel resistance, which indicates that the adjuster pistons are fully retracted. **Figure 3.2.**

- To ensure that the automatic adjustment will occur: Adjust the brake an additional ¼-turn after you reach the resistance point.

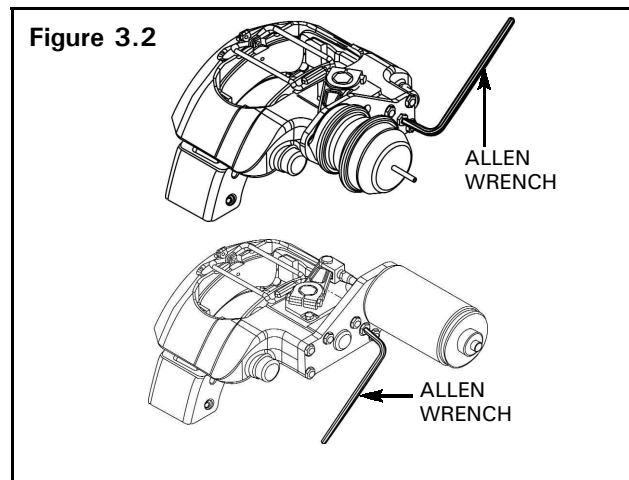
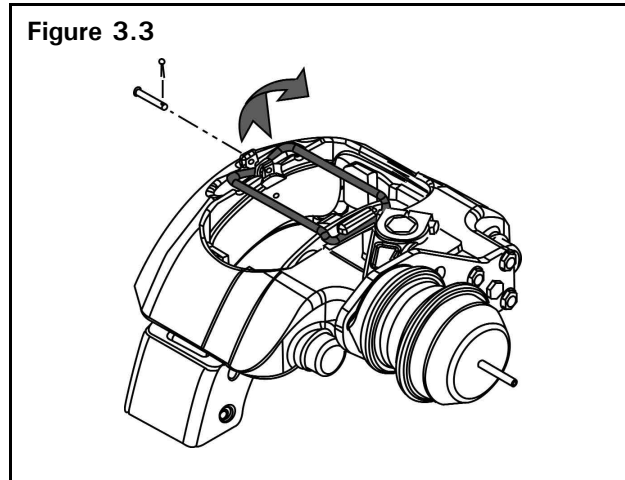


Table A: Increasing and Decreasing Disc Clearance

Caliper Identification	Increase Disc Clearance	Decrease Disc Clearance
LH Air Release Brake Assembly	Counterclockwise	Clockwise
RH Air Release Brake Assembly	Clockwise	Counterclockwise
LH Hydraulic Release Brake Assembly	Counterclockwise	Clockwise
RH Hydraulic Release Brake Assembly	Clockwise	Counterclockwise

- Remove the stabilizer bar cotter pin and retainer pin. Hinge the stabilizer bar so it is out of the way. **Figure 3.3.**



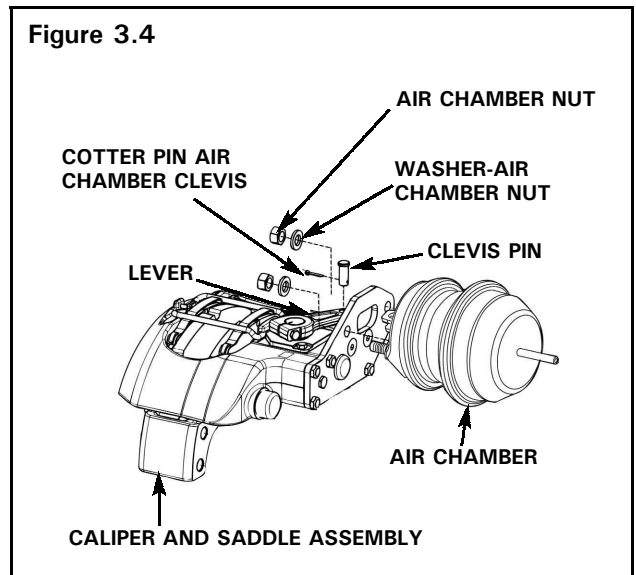
- Lift the inner lining out of the caliper assembly. If you plan to reuse the lining, mark the lining INBOARD.
 - Slide the caliper OUTWARD and remove the outboard lining. If you plan to reuse the lining, mark the lining OUTBOARD.
- NOTE:** If the caliper moves past its working position and jams on the slide pins, use a rubber mallet to move the caliper back to its working range.
- Verify that the caliper slides freely on the slide pins.
 - Remove dirt and dust from the lining contact surfaces of the saddle.
 - Inspect the caliper boots. If the boots are damaged, replace the caliper/saddle assembly.
 - Inspect the disc for wear and damage. Refer to Section 5.

Remove the Caliper Assembly



CAUTION
Do not use the stabilizer bar to lift the caliper on or off of the vehicle. Damage to the stabilizer bar can result.

- Remove the brake linings. Refer to "Remove the Linings" in this section.
- Remove the clevis pin from the lever. **Figure 3.4.**
- Remove the chamber. **Figure 3.4.**
- Remove the four saddle bolts.
- Lift the caliper and saddle assembly away from the disc.
 - If shims are used between the saddle and bracket: Mark the position of the shims.



Install the Caliper Assembly

⚠ WARNING

To prevent serious eye injury, always wear safe eye protection when you perform vehicle maintenance or service.

Use Meritor parts only. Do not use parts manufactured by other suppliers. Use of non-Meritor parts can cause damage, loss of braking and serious personal injury.

1. Lift the caliper over the disc.
 - **If you use shims:** Install the shims in the positions you marked during removal.
2. Align the bottom caliper saddle bolt holes. Install a bolt with hardened washer by hand.
3. Install the remaining saddle bolts by hand. Install the bolts at the top of the caliper first.
4. Tighten the saddle bolts to 400-500 lb-ft (544-680 N·m). **T**
5. Mount the chamber to the caliper assembly. Tighten the chamber nuts and washers to the correct torque. Refer to **Table B.** **T**
6. Install the clevis pin and cotter pin.

Table B: Chamber Nut and Washer Torque Specifications

Brake Type	Torque
Air Release Brake	135-155 lb-ft (180-210 N·m)
Hydraulic Release Brake	30-40 lb-ft (41-54 N·m)

Install the Linings

⚠ CAUTION

Use only the specified components when you service the caliper. Do not mix components from other calipers. If you install the wrong components, the caliper will not operate correctly and can cause damage to the equipment. Use of non-Meritor parts can cause damage, loss of braking and serious personal injury.

Always replace both linings at the same time to ensure brake performance. If only one lining is replaced, damage to the disc can result.

1. Slide the caliper OUTWARD. Install the lining and spring assembly in the OUTBOARD side of the caliper.

NOTE: Replace the linings before the lining material reaches a thickness of 0.200-inch (5.1 mm).

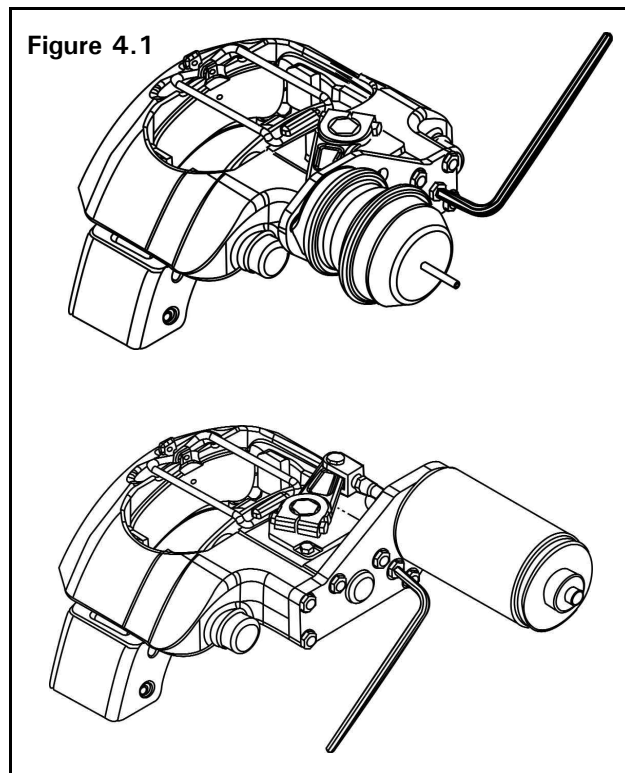
2. **If you reuse the linings:** Install the lining you marked OUTBOARD back into the OUTBOARD position.
3. Slide the caliper INWARD. Install the lining and spring assembly in the INBOARD side of the caliper.


NOTE: Replace the linings before the lining material reaches a thickness of 0.200-inch (5.1 mm).

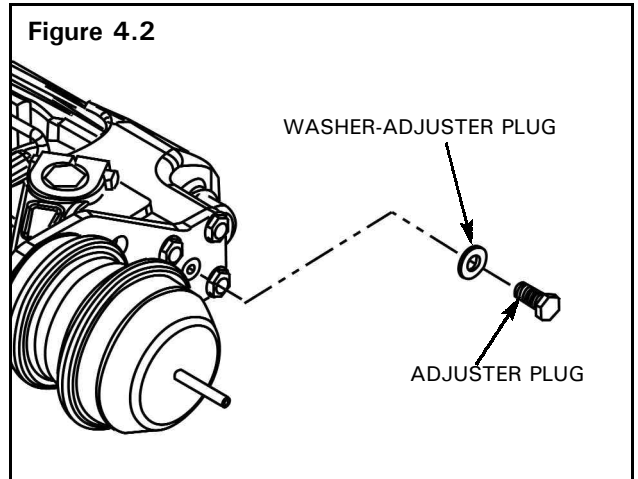
4. **If you reuse the lining:** Install the lining you marked INBOARD back into the INBOARD position.

Adjust the Initial Caliper Clearance

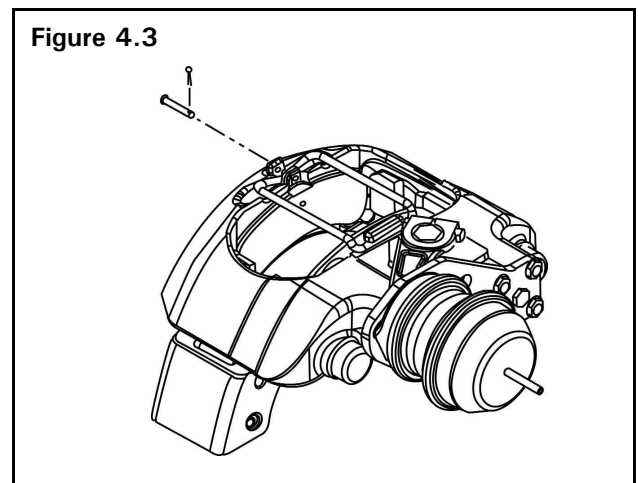
1. Adjust the caliper by reducing the caliper-to-disc clearance to ZERO. Refer to **Table A** for the adjusting direction.
2. Check that the load plate fully contacts the lining backing plate.
3. Use a 6 mm Allen wrench to increase the disc clearance **SEVEN CLICKS**, which sets the initial clearance. **Figure 4.1.**



4. Install the adjuster plug and washer. Tighten the adjuster plug to 8-12 lb-ft (11-17N·m). **Figure 4.2.** 



5. Unhinge the stabilizer bar and return it to position. Install the stabilizer bar pin and cotter pin. **Figure 4.3.**



6. Apply and release the brake assembly 15-20 times to allow the adjuster to set the final caliper clearance.
7. Check the adjusted chamber stroke length. Refer to Section 5.

Hydraulic Fluid

WARNING

Use only the type of hydraulic fluid specified by the equipment manufacturer. Do not use different types of hydraulic fluid. Using incorrect hydraulic fluid will damage the rubber parts of the caliper. Component damage, loss of braking and serious personal injury can result.

Do not reuse hydraulic fluid. Used fluid can be contaminated and cause incorrect operation. Serious personal injury can result.

The brake system uses a petroleum based hydraulic fluid (mineral oil) and includes fluids that meet MIL-H-5606 specifications.

For fluid type and specifications, refer to the equipment manufacturer's recommendations.

Inspection Schedule

Inspect the brake according to one of the following schedules. Choose the schedule that provides the most frequent inspection and lubrication interval.

- The chassis lubrication schedule used by your fleet
- The chassis lubrication schedule recommended by the OEM
- A minimum of four times during the life of the linings
- At tire replacement

Check the Adjusted Chamber Stroke Length

WARNING

To prevent serious eye injury, always wear safe eye protection when you perform vehicle maintenance or service.

Do not work under a vehicle supported only by jacks. Jacks can slip or fall over and cause serious personal injury. Support the vehicle with safety stands. Block the wheels to prevent the vehicle from moving.

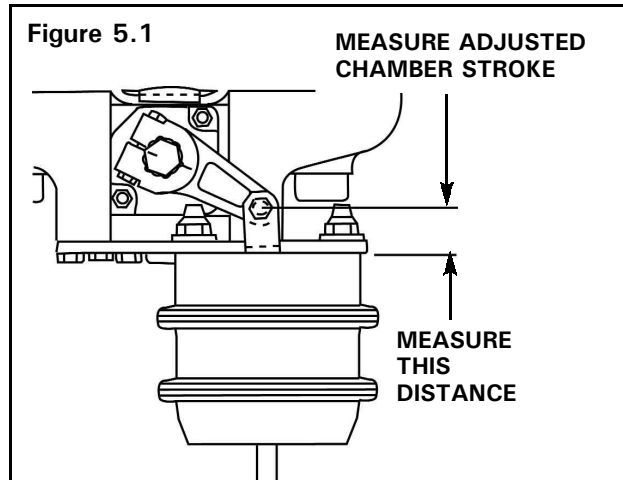
Use the following procedures to check in-service push rod travel.

1. Park the vehicle on a level surface.
2. Place blocks under the wheels.
3. Turn the engine OFF.
4. Check the gauges in the cab. Ensure the tanks contain the correct amount of pressure. Refer to **Table C**.

Table C: Pressure Specifications

Brake Type	Pressure
Air Release Brake	80-120 psi (5.52-8.3 bar)
Hydraulic Release Brake	1700-3000 psi (117.3-207 bar)

5. Measure the distance from the bottom of the chamber to the center of the clevis pin while the brakes are applied. **Figure 5.1.**



6. Have another person release and hold the brakes.
7. Measure the distance from the bottom of the chamber to the center of the clevis pin while the brakes are released.
 - **To determine push rod travel (adjusted chamber stroke):** Subtract the measurement you recorded in Step 5 from the measurement recorded in Step 7. The difference is the push rod travel (adjusted chamber stroke). Push rod travel (adjusted chamber stroke) must not exceed 2.0-inches (50.8 mm).
 - **If push rod travel (adjusted chamber stroke) exceeds specification:** Refer to Section 6.

Inspect the Brake Components

WARNING

Use Meritor parts only. Do not use parts manufactured by other suppliers. Use of non-Meritor parts can cause damage, loss of braking and serious personal injury.

Lining Thickness

Lining material thickness must not be less than 0.200-inch (5.1 mm). Replace the linings before the lining material thickness reaches this specification.

Anti-Rattle Springs

1. Anti-rattle springs are attached to the linings. Inspect for bent, cracked or broken springs.
2. If you find damaged springs, replace both springs.

Seals

Replace the caliper if you find cracked, torn or damaged seals.

CAUTION

Install only the specified components when you service the caliper. Do not mix components from other calipers. Installing non-specified components can cause the caliper to operate incorrectly and can cause equipment damage.

Caliper

1. The caliper should slide freely on the slide pins. Slide the caliper back and forth to check for clearance between the disc and pad.
2. Check that the linings slide freely in the caliper.
3. If components are worn enough to restrict free movement of the caliper or linings, replace the caliper.

Disc

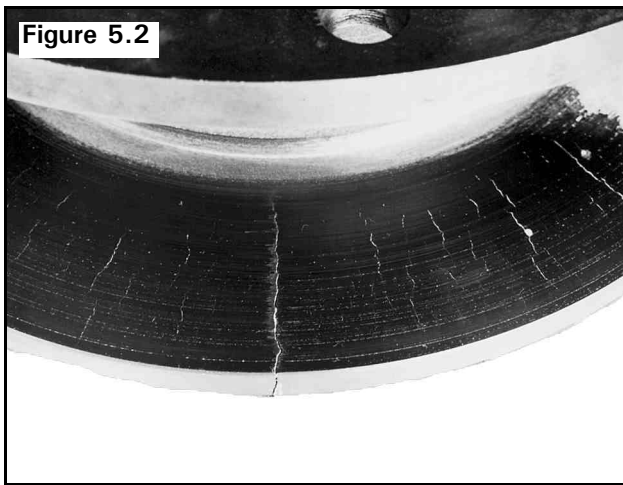
CAUTION

You must always replace a damaged disc.

1. When you inspect the brakes, inspect both sides and the outer diameter of the disc for the following conditions:
 - Cracks
 - Heat checking
 - Grooves or scoring
 - Blue marks or bands
2. When you reline the brakes, you must measure the thickness of the disc.

Cracks

When a crack extends deep into a section of the disc, replace the disc. **Figure 5.2.**



Heat Checking

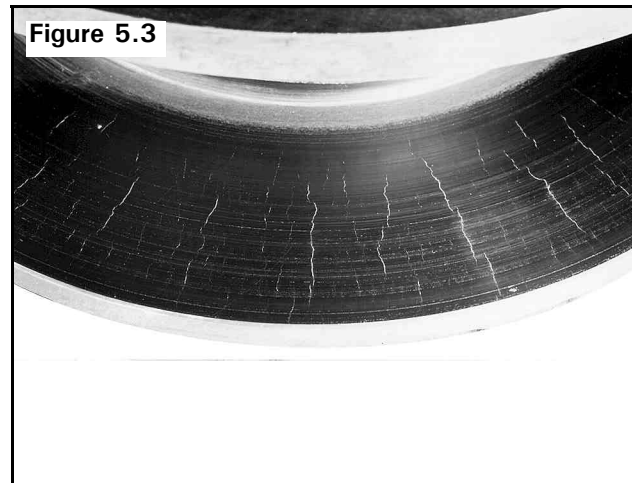
Heat checks are cracks in the surface of the disc caused by heat. Heat checking can be light or heavy.

Light Heat Checking

Light heat checking is very fine, tight, small cracks. Light heat checking is normal. You can continue to use a disc with light heat checking.

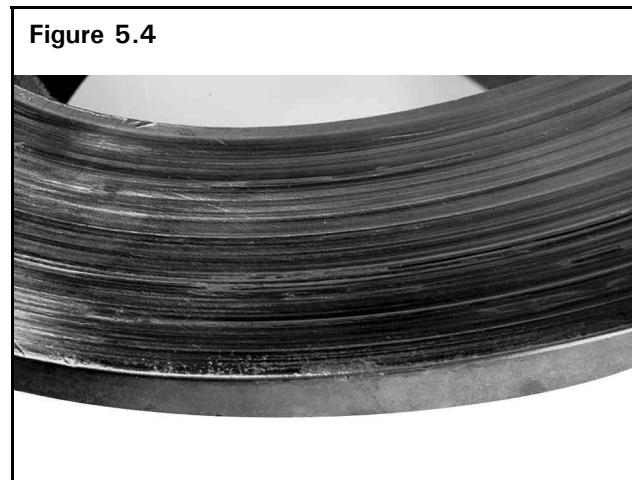
Heavy Heat Checking

Heavy heat checking is surface cracks with width and depth. **Figure 5.3.** If you find heavy heat checking, always replace the disc.



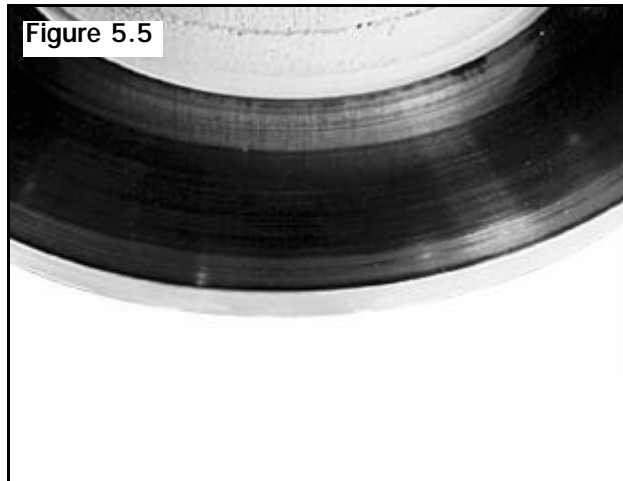
Deep Grooves or Scores

Check both sides of the disc for deep grooves or scores. If the grooves or scores are not too deep, you can continue to use the disc. **Figure 5.4.**



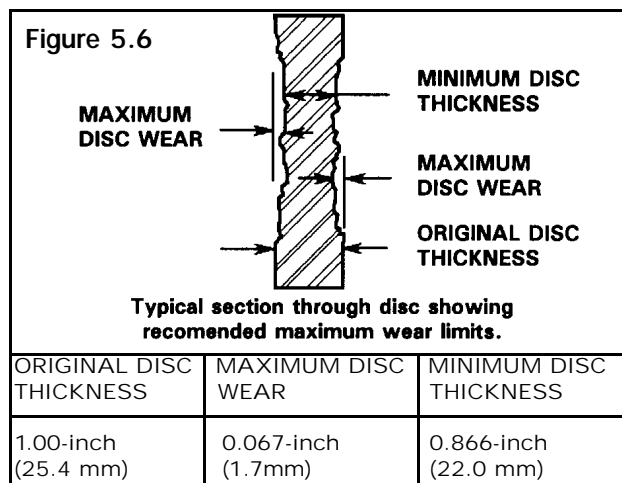
Blue Marks or Bands

Blue marks or bands indicate that the disc was very hot. If blue marks or bands are present, refer to Section 6 to find and correct the cause of the problem. **Figure 5.5.**



Measure Disc Thickness

Measure the thickness of the disc when you reline the brakes. The disc must be at least 0.866-inches (22.0 mm). **Figure 5.6.** If the disc thickness is outside specification, replace the disc.



Caliper Assembly

The caliper and saddle assembly are not serviceable. Replace the brake assembly when a caliper is worn or damaged.

Cleaning



WARNING
To prevent serious eye injury, always wear safe eye protection when you perform vehicle maintenance or service.

Solvent cleaners can be flammable, poisonous and cause burns. Examples of solvent cleaners are carbon tetrachloride, emulsion-type cleaners and petroleum-based cleaners. To avoid serious personal injury when you use solvent cleaners, you must carefully follow the manufacturer's product instructions and these procedures:

- *Wear safe eye protection.*
- *Wear clothing that protects your skin.*
- *Work in a well-ventilated area.*
- *Do not use gasoline or solvents that contain gasoline. Gasoline can explode.*
- *You must use hot solution tanks or alkaline solutions correctly. Follow the manufacturer's instructions carefully.*

Cleaning Ground or Polished Metal Parts

- Use a cleaning solvent to clean ground or polished parts or surfaces. Kerosene or diesel fuel oil can be used for this purpose. NEVER USE GASOLINE.
- Be careful not to damage ground surfaces.
- DO NOT clean ground or polished parts in a hot solution tank, water, steam or alkaline solution.

Cleaning Metal Parts With Rough Finishes

- Parts with a rough finish can be cleaned with cleaning solvent or in a hot solution tank with a weak alkaline solution.
- Parts must remain in hot solution tanks until completely cleaned and heated.
- Parts must be washed with water until the alkaline solution is removed
- Use a wire brush to clean the threads of fasteners and fittings.

Section 5

Maintenance



Cleaning Non-Metal Parts

- Use soap and water to clean non-metal parts.
- Scrape away build-ups of mud and dirt on the linings. Replace all linings contaminated with oil or grease.

Drying Cleaned Parts

- Dry the parts immediately after cleaning and washing.
- Dry the parts with soft clean paper or rags.

Corrosion Protection

Apply rust inhibiting fluid to the cleaned and dried parts that are not damaged and are to be immediately assembled. Do NOT apply fluid to the brake linings or the disc.

If you plan to store the brake parts, apply a special corrosion preventative material to all surfaces. Do NOT apply this material to brake linings or the disc. Store the parts inside special paper or other material that prevents corrosion.

DXP 195 Air Release and Hydraulic Release Parking Disc Brakes

Conditions:	Possible Cause(s):	What to Check:	Corrections:
① Chamber exceeds two-inch maximum stroke requirement	Incorrect initial adjustment or inoperative automatic adjuster	Check the chamber stroke after 20 brake applications.	If the air chamber still overstrokes, replace the caliper/saddle assembly. Refer to Sections 3 and 4.
② Brake drag	Incorrect lining-to-rotor clearance	Minimum stroke 7/8-inch (22 mm)	Replace the caliper/saddle assembly.
	Incorrect initial adjustment		Adjust the rotor to pad clearance. Refer to Section 4.
	Vehicle brake release pressure malfunction	Correct operation of the quick release valve	Repair or replace parts as required.
③ Short outboard brake pad lining life	Caliper seized or sticking on slide pins	Damaged slide-pin seals Caliper should move back and forth by hand with linings removed	Replace the caliper/saddle assembly.
④ Short lining life	Refer to conditions ② and ③.	Refer to conditions ② and ③.	Refer to conditions ② and ③.
	Rotor surface	Cracks or heavy heat checking. Refer to Section 5.	Refer to Section 5 for disc inspection.
⑤ Brake smoking	High brake temperature	Refer to conditions ②, ③ and ④.	Refer to conditions ②, ③ and ④.
	Grease, oil, etc., on the linings	Grease, oil, etc., on the linings	Check for oil leaks in the brake area. Repair as required. Clean the rotor and caliper assembly. Replace the linings. Refer to Sections 3 and 4.
⑥ Poor stopping power • Long stopping distances • Poor driver feel • Lack of normal response	Vehicle brake release pressure malfunction	Correct operation of the quick-release valve	Have the system evaluated by a qualified brake system specialist.
	Brakes out of adjustment	Stroke exceeds two-inch requirement	Refer to condition ①.
	Vehicle overload	Refer to the GAWR limitations on the vehicle I.D. plate.	Observe the vehicle manufacturer's load recommendations.
	Lining contamination	Grease, oil, etc., on the linings	Inspect for oil leaks in the brake area. Repair as required. Clean the rotor and caliper assembly. Replace the linings. Refer to Sections 3 and 4.

Section 7 Specifications



Torque Specifications

Component	Torque
Mounting Bolts	400-500 lb-ft (544-680 N•m)
Chamber Nuts <ul style="list-style-type: none">• Air Release Brakes• Hydraulic Release Brakes	135-155 lb-ft (180-210 N•m) 30-40 lb-ft (41-54 N•m)
Adjustment Plug	8-12 lb-ft (11-17 N•m)



MERITOR™

Notes



MERITOR™
A Heritage of Rockwell Technology

Meritor Heavy Vehicle Systems, LCC

2135 West Maple Road
Troy, MI 48084 U.S.A.
248-435-1085
800-535-5560 (North America only)
www.meritorauto.com

Meritor do Brasil Ltda.

Av. João Batista, 824
06097-900 Osasco-SP
BRAZIL
(55-11) 7084-6510
Fax: (55-11) 7084-6600

Meritor Heavy Vehicle Systems Saint-Etienne S.A.

4, Rue Jean Servanton
Boite Postale 656
42042 Saint Etienne Cedex 1
FRANCE
(33) 477.92.88.00 Fax: (33) 477.92.88.93

Information contained in this publication was in effect at the time the publication was approved for printing and is subject to change without notice or liability. Meritor Automotive, Inc., reserves the right to revise the information presented or discontinue the production of parts described at any time.

Maintenance Manual No. MM-9902
Issued 10-99
VFTIS/Meritor