

# *Digital Video Camera Recorder*

---

## Operating Instructions

Before operating the unit, please read this manual thoroughly,  
and retain it for future reference.

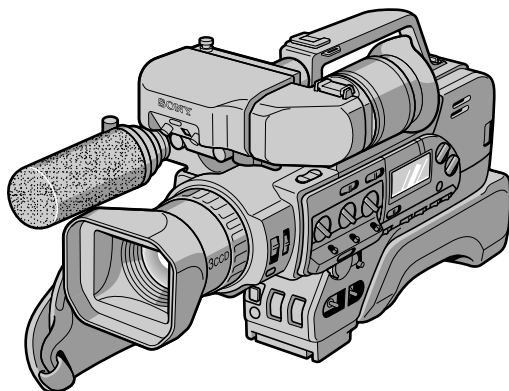

**DV** Digital  
Video  
Cassette

*DCR-VX9000*

# Welcome to digital video!

Congratulations on your purchase of this Sony digital camcorder. With your digital camcorder you can capture life's precious moments with superior picture and sound quality.

Your digital camcorder is loaded with advanced features, but at the same time it is very easy to use. You will soon be producing home video that you can enjoy for years to come.

## **WARNING**

To prevent fire or shock hazard, do not expose the unit to rain or moisture.

To avoid electrical shock, do not open the cabinet.

Refer servicing to qualified personnel only.

# Table of contents

---

## Before you begin

Using this manual .....	4
Checking supplied accessories .....	5

---

## Getting started

Attaching the viewfinder .....	6
Charging and installing the battery pack .....	7
Inserting a cassette .....	10

---

## Basic operations

Camera recording .....	12
Using the zoom feature .....	15
Hints for better shooting .....	16
Checking the recorded picture .....	19
Connections for playback .....	20
Playing back a tape .....	22

---

## Advanced operations

Using alternative power sources .....	24
Changing the mode settings .....	26

### - for camera recording -

Fade-in and fade-out .....	29
Overlapping two pictures .....	30
Using the wide mode function .....	31
Photo recording .....	33
Interval recording .....	34
Cut recording .....	35

### - for manual adjustment -

Selecting automatic or manual mode ..	36
Focusing manually .....	38
Adjusting the aperture .....	41
Adjusting the shutter speed .....	42
Adjusting the gain .....	45
Adjusting the white balance .....	47
Using the ND filter .....	50
Using the zebra pattern .....	51
Adjusting the recording sound .....	52
Releasing the STEADY SHOT function .....	55
Making a custom preset .....	56

### - for editing/playback -

Re-recording a picture in the middle of a recorded tape .....	58
Searching the recorded picture .....	59
Displaying recording data .....	61
Editing onto another tape .....	62
Replacing recording on a tape .....	64
Audio dubbing .....	65

---

## Additional information

Changing the lithium battery in the digital camcorder .....	67
Resetting the date and time .....	69
Notes on video cassettes .....	70
Tips for using the battery pack .....	71
Maintenance information and precautions .....	73
Using your digital camcorder abroad .....	76
Trouble check .....	77
Specifications .....	81
Identifying the parts .....	82
Warning indicators .....	93
Index .....	94

## Using this manual

As you read through this manual, buttons and settings on the digital camcorder are shown in capital letters.

e.g. Set the POWER switch to ON.

As indicated with  $\text{♩}$  in the illustrations, you can hear the beep sound to confirm your operation.

### Note on TV color systems

TV color systems differ from country to country. To view your recordings on a TV, you need an NTSC system-based TV.

### Precaution on copyright

Television programs, films, video tapes, and other materials may be copyrighted. Unauthorized recording of such materials may be contrary to the provision of the copyright laws.

### Precautions on digital camcorder care

- Do not let sand get into the digital camcorder. When you use the digital camcorder on a sandy beach or in a dusty place, protect it from the sand or dust. Sand or dust may cause the unit to malfunction, and sometimes this malfunction cannot be repaired [a].
- Do not let the digital camcorder get wet. Keep the digital camcorder away from rain and sea water. Letting the digital camcorder get wet may cause the unit to malfunction, and sometimes this malfunction cannot be repaired [b].
- Never leave the digital camcorder exposed to temperatures above 60°C (140°F), such as in a car parked in the sun or under direct sunlight [c].

[a]

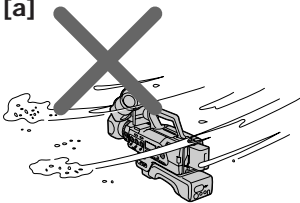

[b]

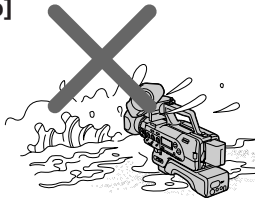

[c]

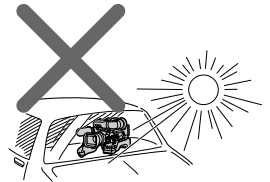

Contents of the recording cannot be compensated if recording or playback is not made due to a malfunction of the digital camcorder, video tape, etc.

# Checking supplied accessories

Check that the following accessories are supplied with your digital camcorder.

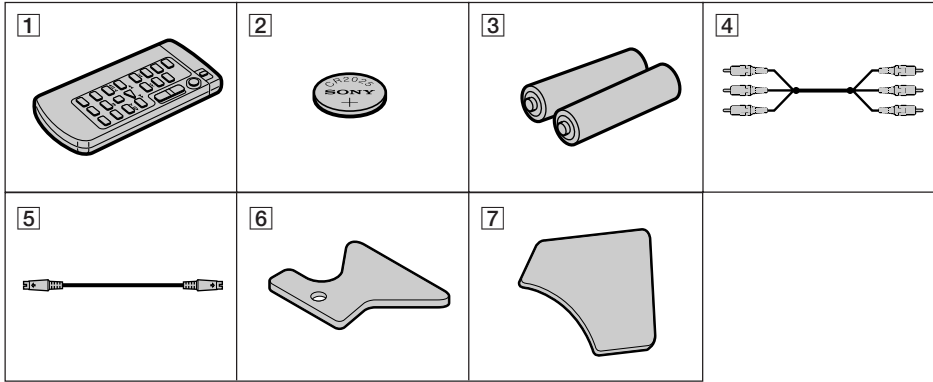

**1** Wireless Remote Commander (1) (p. 87)

**2** CR2025 Lithium Battery (1) (p. 67)  
The lithium battery is already installed in your digital camcorder.

**3** R6 (size AA) battery for Remote Commander (2) (p. 88)

**4** A/V connecting cable (1) (p. 20)

**5** S video cable (1) (p. 20)

**6** Shoulder pad cushion (1) (p. 86)

**7** Side cushion (2) (p. 87)

# Attaching the viewfinder

Before using the digital camcorder, attach the viewfinder.

- (1) Loosen the viewfinder release ring.
- (2) Slide the viewfinder onto the attaching plate.
- (3) Adjust the position of the viewfinder, then tighten the viewfinder release ring.
- (4) Attach the 8 pin connector to the VIEW FINDER jack on the digital camcorder.  
Match ridge on 8 pin connector to the ridge on the jack.

1

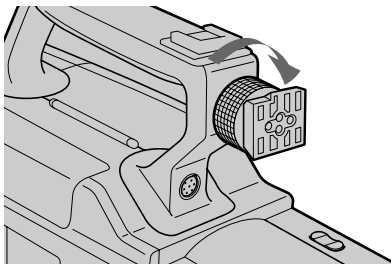

2

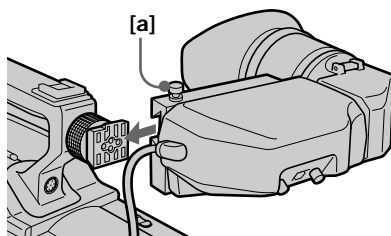

3

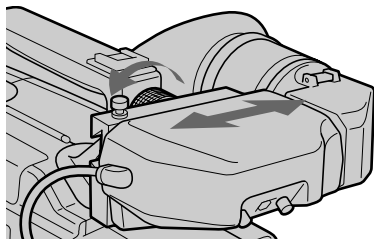

4

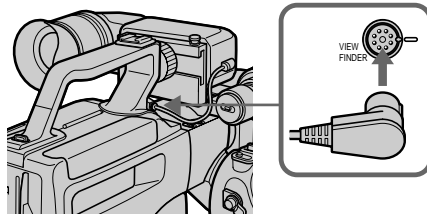

### Note on the VIEW FINDER jack

This VIEW FINDER jack is specially designed for this digital camcorder. Do not connect anything else to this VIEW FINDER jack.

### To remove the viewfinder

Loosen viewfinder release ring. Then pull stopper [a] up, and while holding, slide viewfinder off the attaching plate.

# Charging and installing the battery pack

Before using your digital camcorder, you first need to charge and install the battery pack (not supplied). To charge the battery pack, use the AC-V615 AC power adaptor (not supplied).

This digital camcorder does not interface with "InfoLITHIUM" batteries. The remaining time (minutes) indication does not appear when using "InfoLITHIUM" batteries.

## Charging the battery pack

Charge the battery pack on a flat surface without vibration.

- (1) If your AC power adaptor is direct type, pull down the plug. If it is inlet type, connect the power cord to the AC power adaptor.
- (2) Align the surface of the battery pack indicated by the ► mark with the edge of the terminal shutter of the AC power adaptor. Then fit and slide the battery pack in the direction of the arrow.
- (3) Connect the AC power adaptor to a wall outlet. The CHARGE lamp (orange) lights up. Charging begins.

When the CHARGE lamp goes out, **normal charge** is completed. For **full charge**, which allows you to use the battery longer than usual, leave the battery pack in place for approximately one hour. Unplug the unit from the wall outlet, then remove the battery pack and install it into the digital camcorder. You can also use the battery pack before it is completely charged.

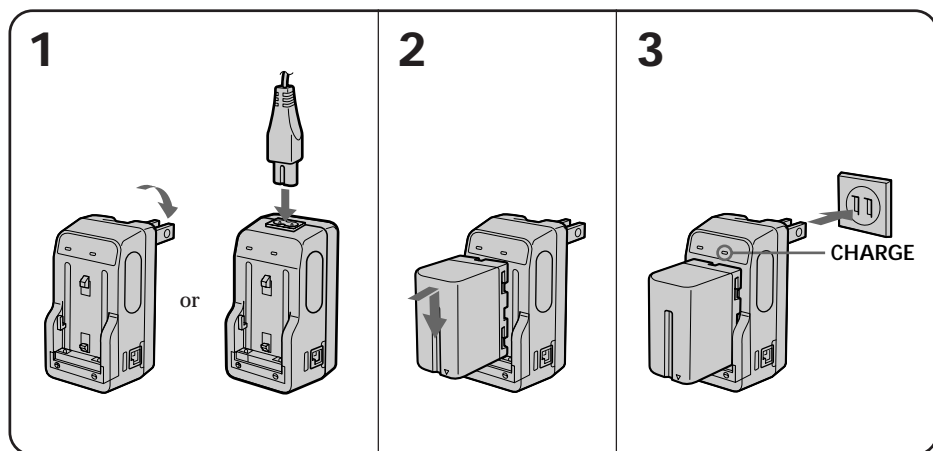

### Charging time

Battery pack	Charging time* (min.)
NP-F730**	250 (190)
NP-F750	270 (210)
NP-F930	330 (270)
NP-F950	360 (300)

The time required for a normal charge is indicated in parentheses.

\* Approximate minutes to charge an empty battery pack using the AC-V615 AC power adaptor. (Lower temperatures require a longer charging time.)

\*\* Some battery packs may not be supplied in some country.

## Charging and installing the battery pack

### Battery life

Battery pack	Continuous recording time*	Typical recording time**
NP-F730	80 (75)	50 (45)
NP-F750	95 (85)	60 (55)
NP-F930	120 (110)	75 (70)
NP-F950	145 (130)	90 (80)

Numbers in parentheses indicate the time when you use a normally charged battery. Battery life will be shorter if you use the digital camcorder in a cold environment.

\* Approximate continuous recording time indoors.

\*\* Approximate minutes when recording while you repeat recording start/stop, zooming and turning the power on/off. The actual battery life may be shorter.

### To remove the battery pack

Slide the battery pack in the direction of the arrow.

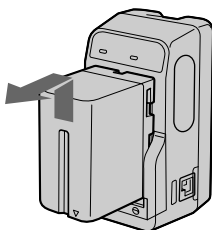

### Notes on charging the battery pack

- The CHARGE lamp will remain lit for a while even if the battery pack is removed and the AC power adaptor is unplugged after charging the battery pack. This is normal.
- If the CHARGE lamp does not light, disconnect the AC power adaptor. After about one minute, reconnect the AC power adaptor again.
- When operating the digital camcorder using the AC power adapter, you cannot charge the battery pack.
- When a fully charged battery pack is installed, the CHARGE lamp will light once, then go out.



## Installing the battery pack

Insert the battery pack in the direction of the ▼ mark on the battery pack. Slide the battery pack down until it catches on the battery release lever and clicks.

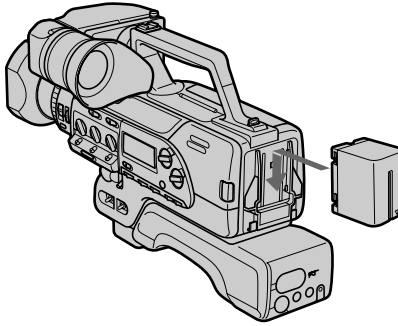

## To remove battery pack

While pressing BATT, lift the battery pack out in the direction of the arrow.

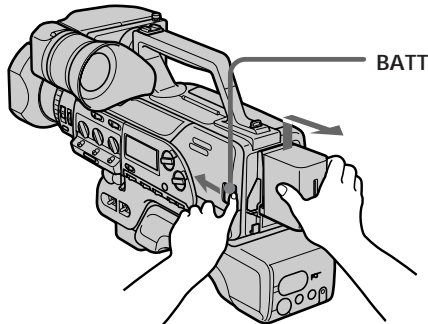

### Note

When you install or remove the battery pack, make sure that the POWER switch is set to OFF.

# Inserting a cassette

Use a DV cassette with **DV** logo\* only.

Make sure that a power source is installed.

We recommend you set the POWER switch to ON before inserting the cassette.

- (1) Open the cassette compartment cover.
- (2) Insert a cassette (not supplied) with the tab upwards, and the window facing out and press down so that the cassette loads.
- (3) Close the cover.

## Notes on the cassette

- Mini DV cassettes with <sup>Mini</sup>**DV** logo cannot be used.
- Do not insert a cassette by force. It may cause a malfunction.
- Do not close the cassette compartment cover when you eject a cassette.
- Keep fingers clear of cassette compartment.
- We recommend you to set the POWER switch to ON when you insert a cassette.

\* **DV** is a trademark.

1

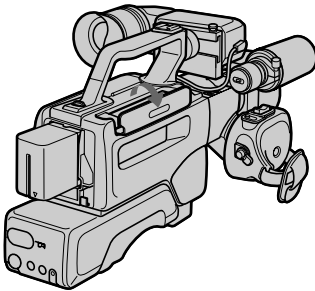

2

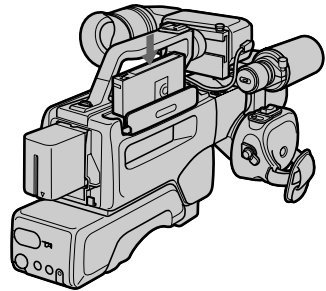

3

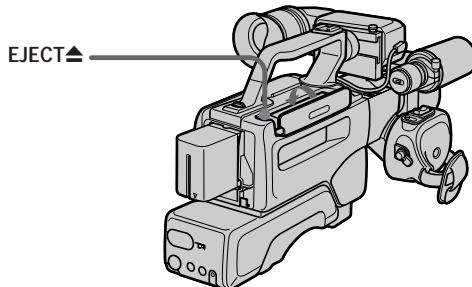

### To eject the cassette

Open the cassette compartment cover and press ▲. After the cassette rises, take it out, then close the cover.

You cannot eject the cassette while C MEMORY appears in the viewfinder because the digital camcorder is still writing information into the cassette memory. After C MEMORY disappears the cassette automatically rises.

When ejecting the cassette, never close the cassette compartment cover until the cassette is completely removed.

### To prevent accidental erasure

Slide the tab on the cassette to expose the red mark. If you insert the cassette with the red mark exposed, the beeps sound, the  and ▲ indicators flash in the viewfinder and display window, and you cannot record.

To re-record on this tape, slide the tab back out, covering the red mark.

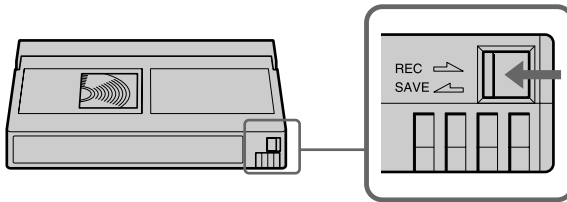

# Camera recording

Make sure that the power source is installed and a cassette is inserted and that AUTO LOCK is set to ON. When AUTO LOCK is set to ON, all settings are automatically adjusted to best suit your shooting environment. Before you record one-time events, you may want to make a trial recording to make sure that the digital camcorder is working correctly.

When you use the digital camcorder for the first time, power on it and reset the date and time to your time before you start recording (p. 69).

- (1) Remove the lens hood cap, and attach it to the grip strap.
- (2) Set the POWER switch to ON.
- (3) Set CAMERA/VTR to CAMERA.
- (4) Turn STANDBY up to STANDBY.
- (5) Press START/STOP.

The digital camcorder starts recording. The "REC" indicator appears and the red lamp lights up in the viewfinder. The tally lamps located on the front and rear also light up.

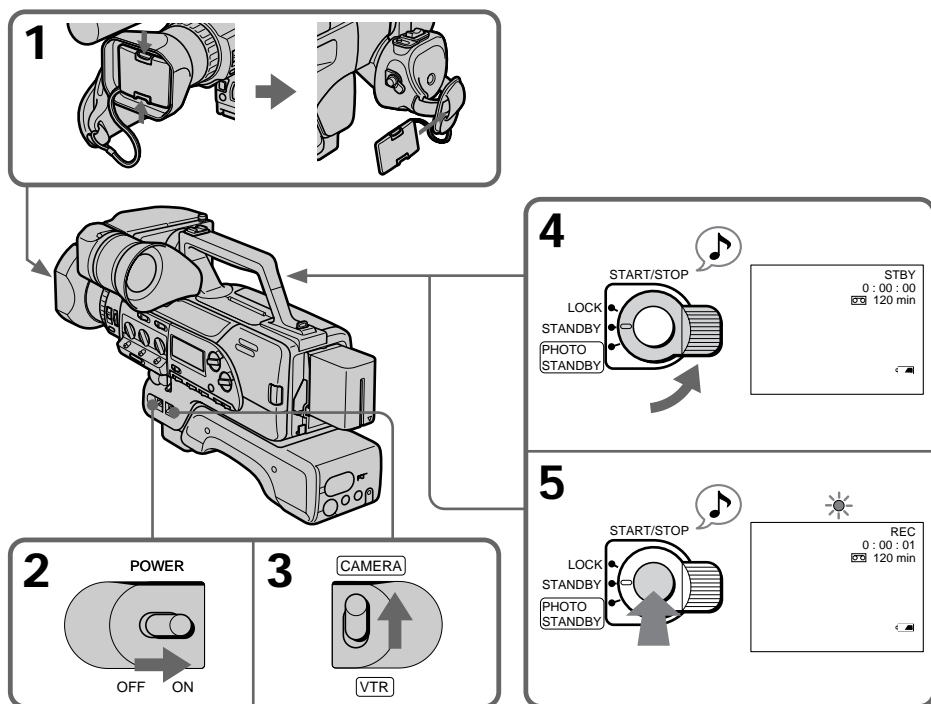

When ND ON flashes in the viewfinder  
Set ND FILTER to ON.

### To stop recording momentarily [a]

Press START/STOP again. The "STBY" indicator appears in the viewfinder (Standby mode).

### To finish recording [b]

Press START/STOP again. Turn STANDBY down to LOCK, and set the POWER switch to OFF. Then, eject the cassette and remove the battery pack.

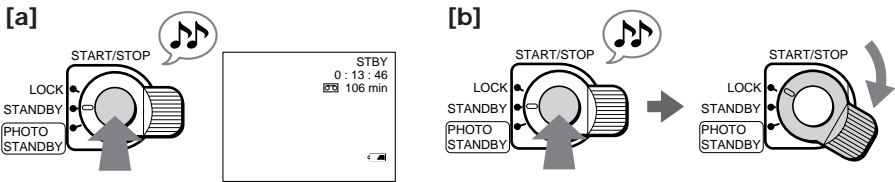

### To focus the viewfinder lens [c]

If you cannot see the indicators in the viewfinder clearly, or after someone else has used the digital camcorder, focus the viewfinder lens. Turn the viewfinder lens adjustment ring so that the indicators in the viewfinder come into sharp focus.

### To adjust the contrast and the brightness of the viewfinder [d]

To adjust the contrast, turn the CONTR knob.

To adjust the brightness, turn the BRIGHT knob.

### If you want to turn off the tally lamp [d]

Set TALLY to OFF.

The rear tally lamp cannot be turned off.

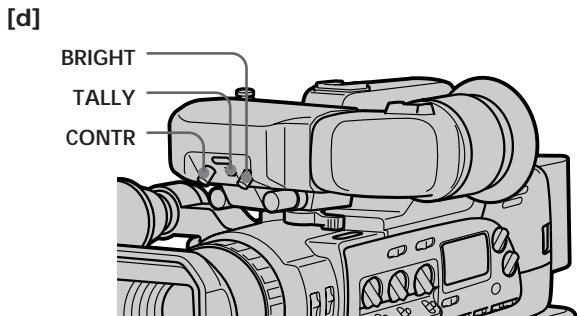
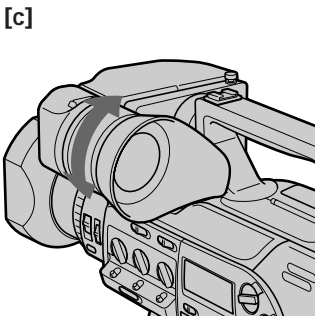

### Note on Standby mode

If you leave the digital camcorder in Standby mode for 5 minutes while a cassette is inserted, the digital camcorder turns off automatically. This prevents wearing down the battery and wearing out the tape. To resume Standby mode, turn STANDBY down and up again. To start recording, press START/STOP.

### Note on time code display

While recording, the time code shows hours, minutes and seconds (0:00:00). While playing back, it shows hours, minutes, seconds and frame number (0:00:00:00). If there is a blank portion between pictures on a tape, the time code restarts from zero. You cannot rewrite the time code only.

The time code of this digital camcorder is the drop frame system.

### Note on recording

When you record from the beginning of a tape, run the tape for about 15 seconds before starting the actual recording. This will ensure that you won't miss any start-up scenes when you play back the tape.

### Note on the beep sound

As indicated with  in the illustration, a beep sounds when you turn the power on or when you start recording, and two beeps sound when you stop recording, confirming the operation. Several beeps also sound as a warning of any unusual condition of the digital camcorder.

Note that the beep sound is not recorded on the tape. If you do not want to hear the beep sound, select "OFF" in the menu system.

### To change the directionality of the built-in microphone

Set DIRECTION SELECT on the back of the microphone to the desired position (0°/90°/120°).

### To record through an external microphone

Connect a microphone (not supplied) to the MIC (PLUG IN POWER) jack. In this case, sound from the built-in microphone will not be recorded. You can also attach a microphone to the accessory shoe.

### To monitor the sound while recording

Use headphones or the built-in speaker. To turn on the built-in speaker, set SPEAKER to ON. To use headphones, connect them to the  jack. Use the MONITOR LEVEL dial to adjust the volume of the speaker or headphones. When using headphones the built-in speaker becomes inactive.

When monitoring the built-in speaker, feedback may occur. In this case, turn down the MONITOR LEVEL or SPEAKER set to OFF.

### To select 16 bit [a] or 12 bit [b] recording mode

Set AUDIO MODE to 16 BIT so that you can get higher sound quality. In 16 bit mode, the digital camcorder records one video sector [c] and one audio sector [d]. In the viewfinder the "16 BIT" indicator appears.

Set AUDIO MODE to 12 BIT, and 1 sector is left open for audio dubbing afterwards. In 12 bit mode, the digital camcorder records one video sector [c], one audio sector [d], and one blank audio sector [e], which enables you to add narration or music after the initial recording.

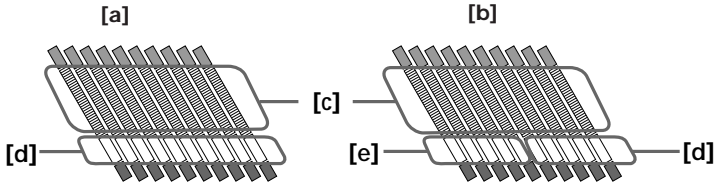

#### Notes on recording mode

- If you change the recording mode while recording, a blank portion may be recorded on a tape.
- You cannot operate audio dubbing on 16 bit recorded tapes.

### Using the zoom feature

Zooming is a recording technique that lets you change the size of the subject in the scene.

For more professional-looking recordings, use the zoom function sparingly.

"T" side: for telephoto (subject appears closer)

"W" side: for wide-angle (subject appears farther away)

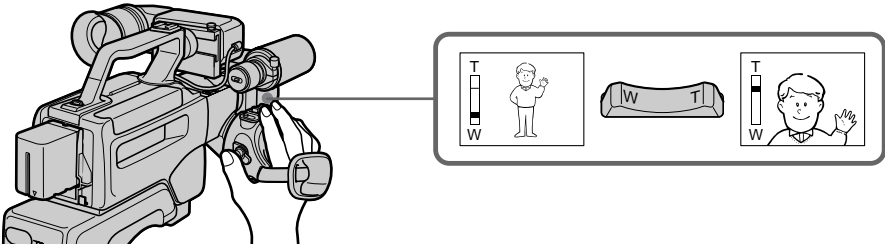

#### Zooming speed (Variable speed zooming)

Press the power zoom button a little for a slower zoom, press it more for a faster zoom.

## Camera recording

### When you shoot a subject using a telephoto zoom

If you cannot get a sharp focus while in extreme telephoto zoom, press the power zoom button to the “W” side until the focus is sharp. You can shoot a subject that is at least about 80 cm away from the lens surface in the telephoto position, or about 1 cm away in the wide-angle position.

### Notes on digital zoom

- More than 10x zoom is performed digitally if you set D ZOOM to ON in the menu system, and the picture quality deteriorates as you go toward the “T” side. To turn on the digital zoom function, set DIGITAL MODE to ZOOM/16:9 WIDE, then set D ZOOM to ON in the menu system. To turn it off, set D ZOOM to OFF. If you set DIGITAL MODE to OVERLAP, D ZOOM is automatically set to OFF.
- The upper side [a] of the power zoom indicator shows the digital zooming zone, and the lower side [b] shows the optical zooming zone. If you set the D ZOOM function to OFF, the [a] zone disappears.

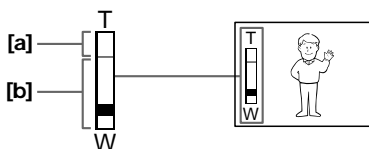

## Hints for better shooting

When shooting with the digital camcorder on your shoulder, you'll get better results by holding the digital camcorder according to the following suggestions:

- Place the digital camcorder on your shoulder and secure it with the grip strap so that you can easily manipulate the controls with your thumb.
- To adjust the grip, loosen the grip screw [a] with a coin, rotate the grip, and then tighten the screw. Set the grip to one of the three different position marks.

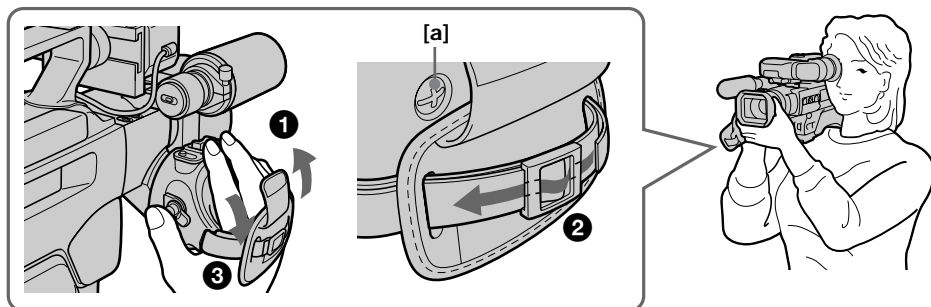

- Place your right elbow against your side.
- Place your left hand under the digital camcorder to support it. Be sure to not touch the built-in microphone.
- Place your eye firmly against the viewfinder eyecup.
- Use the viewfinder frame as a guide to determine the horizontal plane.



## Hints for better shooting

- You can also record in a low position to get an interesting angle. Lift the viewfinder up for recording from a low position [b].
- While recording in a low position, you can use the front START/STOP button [c].
- You can rotate the viewfinder 120° up and 90° down. This is useful when recording in a high or low position [d].

[b]



[c]

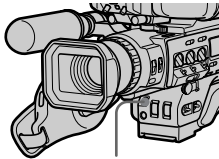

START/STOP

[d]

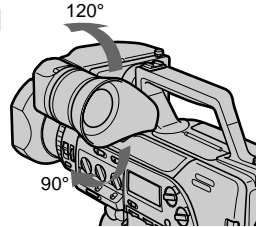

- You can move the viewfinder up to about 30 mm laterally. Turn the lock ring to release the viewfinder, and then move it. Turn back the lock ring to fix the viewfinder in place [e].
- You can move the viewfinder up to about 30 mm lengthwise. Turn the lock lever under the viewfinder to release it, and then move the viewfinder. Turn back the lock lever to fix the viewfinder in place [f].
- To change the position of the shoulder pad, loosen the two screws under the shoulder pad and move the shoulder pad [g]. Then tighten the screws well.

[e]

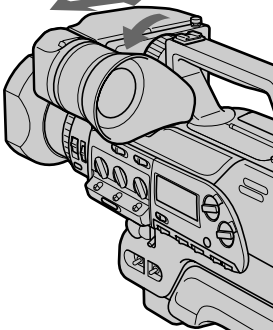

[f]

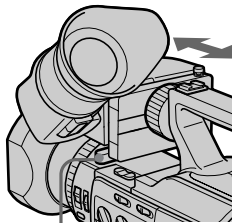

[g]

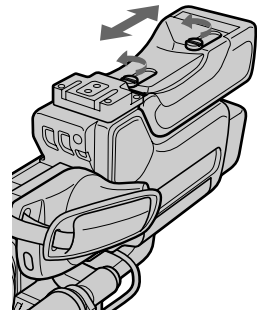

Release

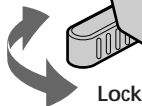

Lock

## Hints for better shooting

### Place the digital camcorder on a flat surface or use a tripod

Try placing the digital camcorder on a table top or any other flat surface of suitable height. If you have a tripod for a still camera, you can also use it with the digital camcorder.

When attaching a non-Sony tripod, make sure that the length of the tripod screw is less than 6.5 mm. Otherwise, the screw may damage the inner parts of the digital camcorder.

When you attach, maintain and tighten screw firmly to prevent this digital camcorder falling over.

### Caution on carrying

Do not pick up the digital camcorder by anything other than the grip or handle [h].

### Caution on the viewfinder

Do not place the digital camcorder so as to point the viewfinder toward the sun. The inside of the viewfinder may be damaged.

Be careful when placing the digital camcorder under sunlight or by a window [i].

[h]

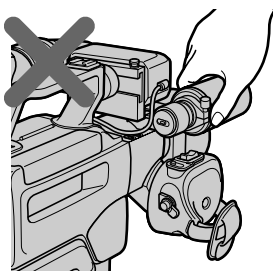
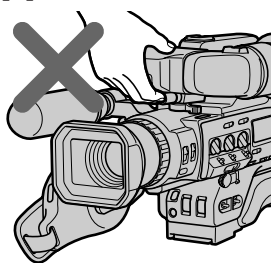

[i]

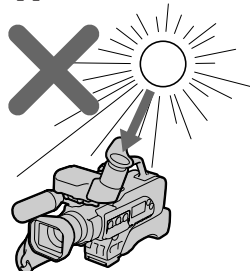

### Note on the viewfinder

When attaching the video light (not supplied) to the accessory shoe, do not lift the viewfinder. The video light heat may damage the eyecup.

# Checking the recorded picture

Using EDITSEARCH, you can review the last recorded scene or check the recorded picture in the viewfinder.

- (1) Set the POWER switch to ON and then set CAMERA/VTR to CAMERA.
- (2) Turn STANDBY up to STANDBY.
- (3) Press the - (⊖) side of EDITSEARCH momentarily; the last few seconds of the recorded portion play back (Rec Review).

Hold down the - side of EDITSEARCH until the digital camcorder goes back to the scene you want. The last recorded portion is played back. To go forward, hold down the + side (Edit Search).

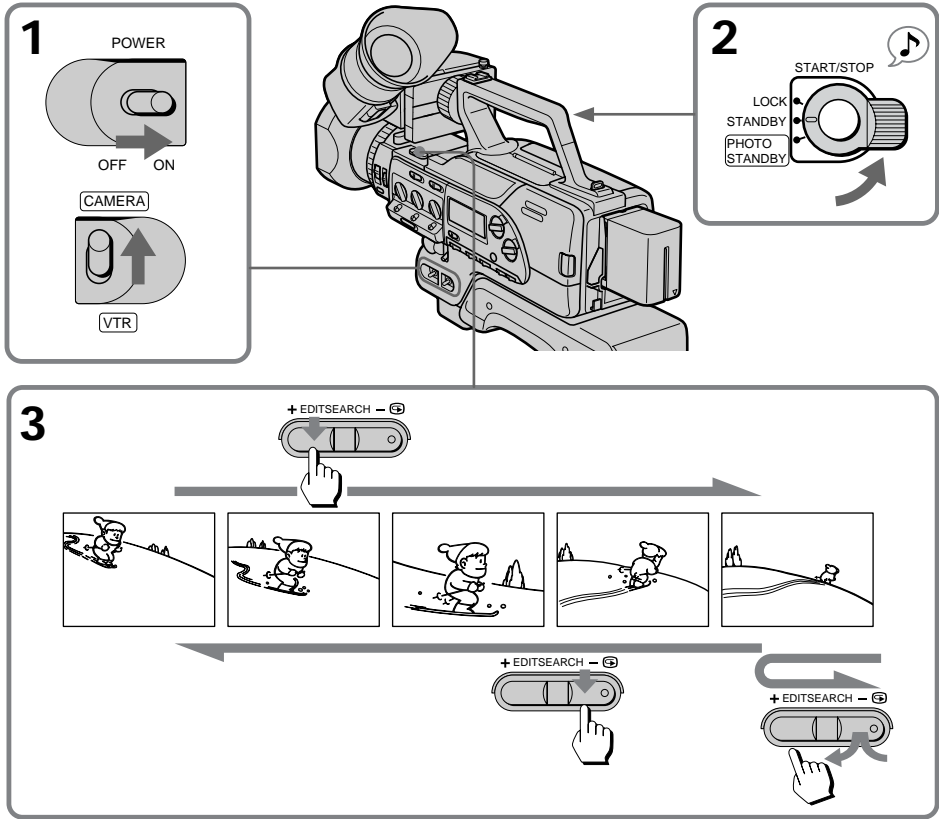

## To stop playback

Release EDITSEARCH.

## To begin re-recording

Press START/STOP. Re-recording begins from the point you released EDITSEARCH. Provided you do not eject the cassette, the transition between the last scene you recorded and the next scene you record will be smooth.

## Note on the EDITSEARCH

If you press EDITSEARCH fully, the playback speed doubles.

# Connections for playback

You can use this digital camcorder as a VCR by connecting it to your TV for playback. There are some ways to connect the digital camcorder to your TV. When monitoring the playback picture by connecting the digital camcorder to your TV, we recommend you to use house current for power source.

## Connecting directly to a TV/VCR with Video/Audio input jacks

### If you connect directly to a TV

Open the jack cover and connect the digital camcorder to the inputs on the TV by using the supplied A/V connecting cable. Set the TV/VCR selector on the TV to VCR.

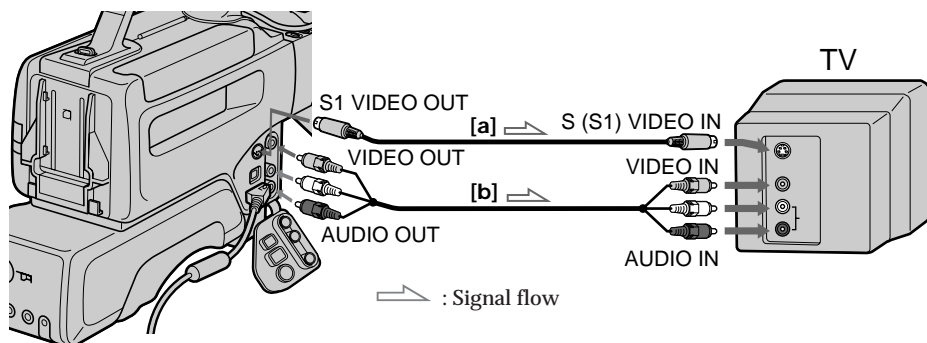

If you are going to connect the digital camcorder using the S video cable [a], you do not need to connect the yellow (video) plug of the A/V connecting cable [b]. If your TV has S (S1) VIDEO IN jack and it is connected with S1 VIDEO OUT on this digital camcorder, it turns to a wide picture automatically when you play back wide picture recorded by this digital camcorder.

### If your TV is already connected to a VCR

Open the jack cover and connect the digital camcorder to the LINE IN inputs on the VCR by using the supplied A/V connecting cable. Set the input selector on the VCR to LINE. Set the TV/VCR selector on the TV to VCR.

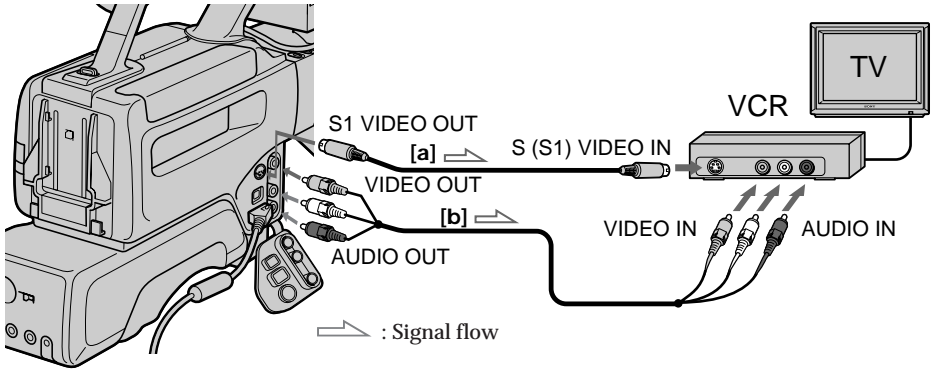

### If your TV or VCR is a monaural type

Connect only the white plug for audio on both the digital camcorder and the VCR or the TV. With this connection, the sound is monaural.

### To connect to a TV or VCR without Video/Audio input jacks



Use an RFU adaptor (not supplied).

# Playing back a tape

You can monitor the playback picture in the viewfinder. You can also monitor the picture on a TV screen, after connecting the digital camcorder to a TV or VCR.

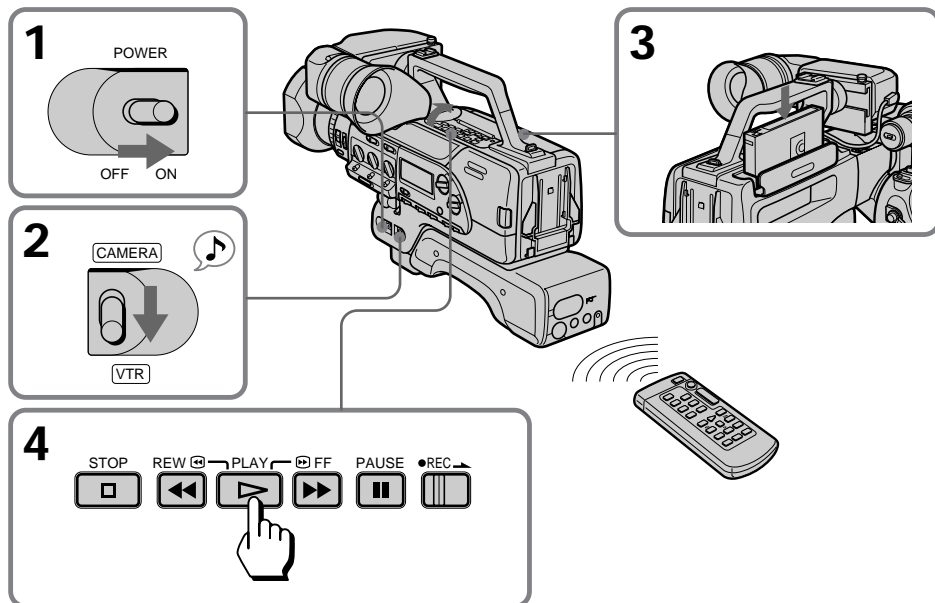
- (1) Set the POWER switch to ON
- (2) Set CAMERA/VTR to VTR.
- (3) Insert the recorded tape with the window facing out.
- (4) Open the cover, then press  to start playback.



- To stop playback, press .
- To rewind the tape, press .
- To fast-forward the tape rapidly, press .

To mark the portion you want to monitor again  
Press ZERO SET MEMORY while playing back. After you finish playing back, press . The tape rewinds to the position you want (0:00:00) and stops.

## To monitor the sound while viewing the playback picture in the viewfinder

Connect headphones (not supplied) to the  jack or turn on the built-in speaker by setting SPEAKER to ON.

## Using the Remote Commander

You can control playback using the supplied Remote Commander. Before using the Remote Commander, insert the R6 (size AA) batteries.

### Note on the DISPLAY button on the remote commander

Press DISPLAY to display the screen indicators. To erase the indicators, press DISPLAY again.

## Various playback modes

### To view a still picture (playback pause)

Press **II** during playback. To resume playback, press **II** or **▷**.

### To locate a scene (picture search)

Keep pressing **◀◀** or **▶▶** during playback. To resume normal playback, release the button.

### To monitor the high-speed picture while advancing the tape or rewinding (skip scan)

Keep pressing **◀◀** while rewinding or **▶▶** while advancing the tape. To resume normal playback, press **▷**.

### To view the picture at 1/5 speed (slow playback)

Press **II▶** during playback. To resume normal playback, press **▷**. If slow playback lasts for about 1 minute, it shifts to normal speed automatically.

### To view the picture at double speed

For double speed playback in the reverse direction, press **◀II/<**, then press **x2** on the Remote Commander during playback. For double speed playback in the forward direction, press **>/II▶**, then press **x2** during playback. To resume normal playback, press **▷**.

### To view the picture frame-by-frame

Press **◀II/<** or **>/II▶** in playback pause mode. If you keep pressing the button, you can view the picture at 1/30 speed. To resume normal playback, press **▷**.

### To change the playback direction

Press **◀II/<** for reverse direction or **>/II▶** for forward direction during playback. To resume normal playback, press **▷**.

### Notes on playback

- Streaks appear and the sound is muted in the various playback modes.
- When playback pause mode is left on for 5 minutes, the digital camcorder automatically enters stop mode.
- When using playback slow or still picture modes, images from the previous frames might be seen mixed in with the main picture.

## Using alternative power sources

You can choose any of the following power sources for your digital camcorder: battery pack and house current. Choose the appropriate power source depending on where you want to use your digital camcorder.

Place	Power source	Accessory to be used
Indoors	House current	AC power adaptor AC-V615
Outdoors	Battery pack	Battery pack NP-F950, NP-F930, NP-F750, NP-F730

### Note on AC power adaptor

Do not use anything other than the AC-V615 AC power adaptor with this digital camcorder.

### Note on battery pack

Some battery packs may not be supplied in some country.

### Note on power sources

Disconnecting the power source or removing the battery pack during recording or playback may damage the inserted tape. If this happens, restore the power supply again immediately.

## Using the mains

- (1) If your AC power adaptor is direct type, pull down the plug. If it is inlet type, connect the power cord to the AC power adaptor.
- (2) Connect the AC power adaptor to a wall outlet, then connect the connecting cord to the DC OUT jack on the AC power adaptor.
- (3) Connect the connecting cord to the DC IN jack on the digital camcorder.

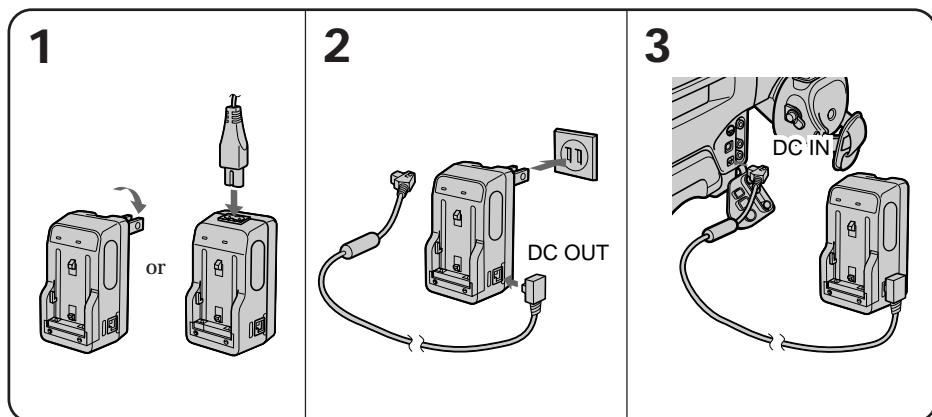



### Charging the attached battery pack

After connecting the AC power adaptor to the wall outlet and setting the POWER switch on the digital camcorder to OFF, you can charge the battery pack in either of the following two ways:

- Charging the battery pack attached to the digital camcorder  
Leave the battery pack attached to the digital camcorder. (The NP-F950 battery pack requires about 430 minutes for a full charge and about 370 minutes for a normal charge.)

While charging, the battery indicator appears repeatedly in the display window:



- Charging two battery packs at the same time  
Attach one battery pack to the AC power adaptor and the other to the digital camcorder. Both are charged simultaneously. When charged, CHARGE lamp and the  indicator goes out (normal charge). If either lamp is still lit, both battery packs are not charged (the NP-F950 battery packs require about 530 minutes for a full charge and about 460 minutes for a normal charge).

### To remove the adaptor

Pull out by the plug. Never pull on the connecting cord itself.

### WARNING

The power cord must only be changed at a qualified service shop.

### PRECAUTION

The set is not disconnected from the AC power source (mains) as long as it is connected to the wall outlet, even if the set itself has been turned off.

### Notes on the VTR/CAMERA lamp

- The VTR/CAMERA lamp will remain lit for a while even if the unit is unplugged after use. This is normal.
- If the VTR/CAMERA lamp does not light, disconnect the AC power adaptor. After about one minute, reconnect the AC power adaptor.

# Changing the mode settings

You can change the mode settings in the menu system to further enjoy the features and functions of the digital camcorder.

- (1) Open the cover, then press MENU to display the menu.
- (2) Press  $\nabla$  or  $\blacktriangle$  to select the desired item, then press EXECUTE.
- (3) Press  $\nabla$  or  $\blacktriangle$  to select the desired setting, then press EXECUTE.  
For some items, you may need to repeat steps 2 and 3.
- (4) Press MENU to erase the menu display.

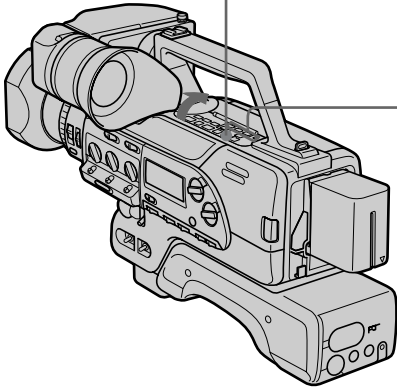



**1**

CAMERA	VTR
MENU	MENU
D ZOOM → OFF	COMMANDER → VTR4
16 : 9 WIDE	BEEP
ZEBRA	AUDIO MIX
COMMANDER	WIDE PB
BEEP	CM SEARCH
FRAME REC	DATA CODE
INT REC	CLOCK SET
↓	
[ MENU ] : END	[ MENU ] : END

**2**

1



2

EXECUTE

MENU

D ZOOM → OFF

16 : 9 WIDE → OFF

ZEBRA

COMMANDER → ON

BEEP

FRAME REC

INT REC

↓

[ MENU ] : END

MENU

BEEP



ON

OFF

[ MENU ] : END

**3**

1



2

EXECUTE

MENU

BEEP

ON

OFF

[ MENU ] : END

MENU

D ZOOM

16 : 9 WIDE

ZEBRA

COMMANDER → OFF

BEEP

FRAME REC

INT REC

↓

[ MENU ] : END

## Selecting the mode setting of each item

### Items for both CAMERA and VTR modes

#### COMMANDER\* <VTR4/OFF/ID/ID SET>

- Normally select VTR4.
- Select OFF when not using the Remote Commander.
- Select ID when using the Remote Commander with the ID number set.
- Select ID SET when setting the ID number of the Remote Commander.

#### BEEP\* <ON/OFF>

- Select ON so that beeps sound when you start/stop recording, etc.
- Select OFF when you do not want to hear the beep sound.

#### CLOCK SET\*

Reset the date and time.

### Items for CAMERA mode only

#### D ZOOM\* <OFF/ON>

Before turning on D ZOOM, set the DIGITAL MODE switch to ZOOM/16:9 WIDE.

- Select OFF to not use the digital zoom.
- Select ON to activate digital zooming. More than 10x zoom is performed digitally.

#### 16:9 WIDE\* <OFF/ON>

Before turning on 16:9 WIDE, set DIGITAL MODE to ZOOM/16:9 WIDE.

- Normally select OFF.
- Select ON to record a 16:9 wide picture to watch on a wide-screen TV.

#### ZEBRA\* <OFF/ON>

- Normally select OFF.
- Select ON to shoot with the zebra pattern displayed in the viewfinder.

#### FRAME REC <OFF/ON>

- Normally select OFF.
- Select ON for cut recording.

#### INT REC <RETURN> <SET> <INTERVAL\*/REC TIME\*>

- Select RETURN to return to the menu to change other menu items.
- Select SET to set interval recording ON or OFF.
- Select INTERVAL to set or change the interval time for interval recording.
- Select REC TIME to set or change the recording time for interval recording.

#### SLOW SHTR\* <4/8/15/30>

Before setting, turn the SHUTTER SPEED dial to SLOW.  
Select a slow shutter speed.

#### S PRESET\* <60/100/250/500/1000/2000/4000/10000>

Before setting, turn the SHUTTER SPEED dial to PRESET.  
Select a shutter speed.

#### G PRESET\* <-3dB/0dB/3dB/6dB/9dB/12dB/15dB/18dB>

Before setting, turn the GAIN dial to PRESET.  
Select a gain level.

## Changing the mode settings

**CUSTOM\*** <RETURN> <SET> <COLOR LEV/SHARPNESS/WB SHIFT/AE SHIFT>  
<RESET>

- Select RETURN to return to the menu to change other menu items.
- Select SET to set custom preset ON or OFF.
- Select COLOR LEV/SHARPNESS/WB SHIFT/AE SHIFT to preset the color intensity (COLOR LEV), sharpness (SHARPNESS), white balance (WB SHIFT), and brightness (AE SHIFT) of the picture.
- Select RESET to restore the default settings.

### Items for VTR mode only

#### AUDIO MIX\*

When playing back a tape recorded with 12 bit, select this item to adjust the volume balance between audio mode ST1 and ST2.

#### WIDE PB\* <OFF/ON>

- Normally select OFF.
- Select ON to playback a picture recorded in the 16:9 wide mode to watch on a normal (4:3) TV.

#### CM SEARCH\* <ON/OFF>

- Normally select ON to turn on the cassette memory search function.
- Select OFF to search without using the cassette memory function.

#### DATA CODE\* <DATE/CAM or DATE>

- Select DATE/CAM to display date and time, as well as various settings data, of your recordings.
- Select DATE to display date and time, of your recordings.

#### When DIGITAL MODE is set to OVERLAP

You cannot set 16:9 WIDE and D ZOOM to ON. When you set the DIGITAL MODE switch to OVERLAP, 16:9 WIDE and D ZOOM settings are changed to OFF automatically.

#### About FRAME REC and INT REC setting

Both settings are automatically set to off when:

- The POWER switch is set to OFF.
- CAMERA/VTR is set to VTR.
- Turn STANDBY up to PHOTO STANDBY.

\* These settings are retained even when the battery is removed, as long as the lithium battery is in place.

# Fade-in and fade-out

You can fade in or out to give your recording a professional appearance. When fading in, the picture gradually fades in from white while the sound increases. When fading out, the picture gradually fades to white while the sound decreases. To use fade-in and fade-out, press FADER/OVERLAP to display FADER in the viewfinder.

## When fading in [a]

- (1) While the digital camcorder is in Standby mode, press FADER/OVERLAP. The fade indicator starts flashing.
- (2) Press START/STOP to start recording. The fade indicator stops flashing.

## When fading out [b]

- (1) During recording, press FADER/OVERLAP. The fade indicator starts flashing.
- (2) Press START/STOP to stop recording. The fade indicator stops flashing, and then recording stops.

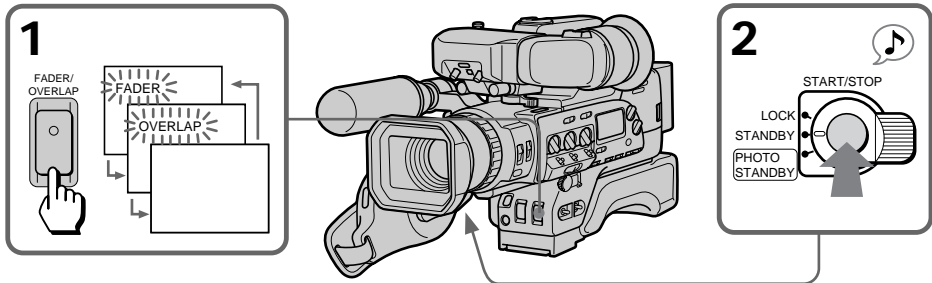

## To cancel the fade-in/fade-out function

Before pressing START/STOP, press FADER/OVERLAP until the indicator disappears.

## Note on the fade-in/fade-out function

You cannot fade-in or fade-out while recording with interval recording, cut recording, or photo recording.

# Overlapping two pictures

When using the overlap function, the picture gradually fades in over a still picture of the last scene recorded.

- (1) While the digital camcorder is in Standby mode, set DIGITAL MODE to OVERLAP.
- (2) Press FADER/OVERLAP repeatedly until "OVERLAP" appears in the viewfinder.
- (3) Press START/STOP to start recording.

The scene being shot gradually fades in over the still picture of the last recorded scene.

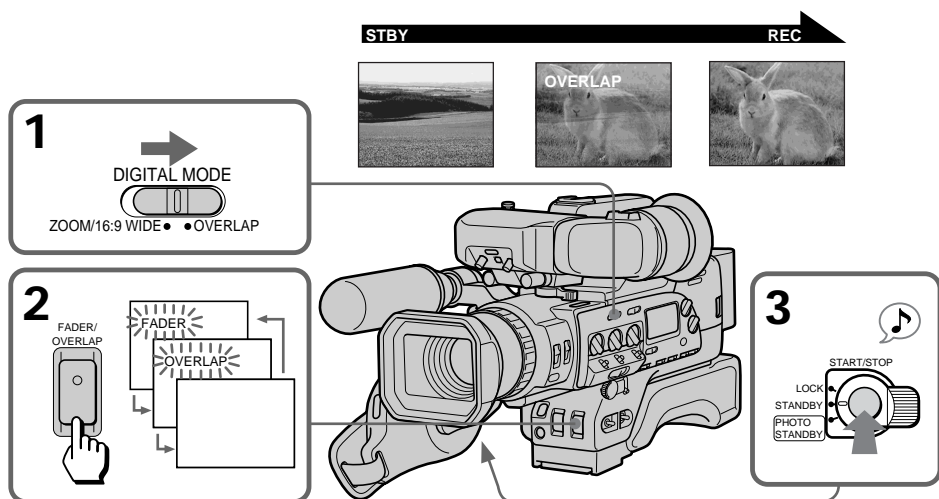

## To cancel the overlap function

Before pressing START/STOP, press FADER/OVERLAP until the indicator disappears.

### Notes on the overlap function

- You cannot use the overlap function while recording with interval recording, cut recording, or photo recording.
- When in Standby mode select OVERLAP, the digital camcorder automatically goes into picture search, then the last recorded scene is stored for overlap.
- When you set DIGITAL MODE to OVERLAP, 16:9 WIDE and D ZOOM settings are set to OFF automatically.

# Using the wide mode function

You can record a 16:9 wide picture to watch on a 16:9 wide-screen TV.

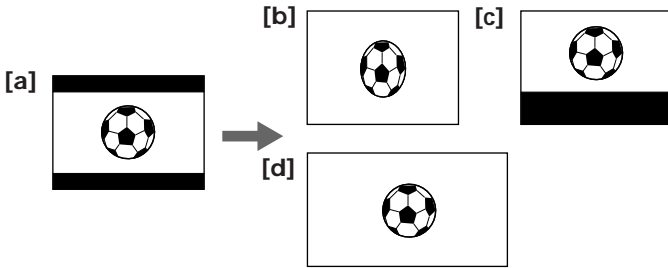

In the viewfinder black bands appear at the top and bottom of the screen [a].

On a normal TV screen, the picture appears horizontally compressed [b].

When setting WIDE PB to ON in the menu system, you get a cinema-like picture with a black band at the bottom of the screen [c].

You can watch the picture of normal images on a wide-screen TV [d].

- (1) While the digital camcorder is in Standby mode, set DIGITAL MODE to ZOOM/16:9 WIDE.
- (2) Open the cover, then press MENU to display the menu in the viewfinder.
- (3) Press  $\wedge$  or  $\vee$  to select 16:9 WIDE, then press EXECUTE.
- (4) Press  $\wedge$  or  $\vee$  to select ON, then press EXECUTE.
- (5) Press MENU to erase the menu display.

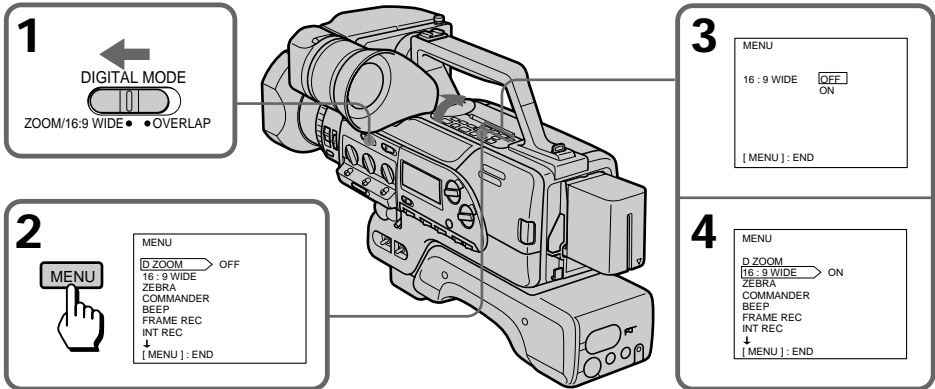

### **To cancel wide mode**

Set 16:9 WIDE to OFF in the menu system.

### **To watch a tape recorded in 16:9 wide mode on a wide-screen TV**

Set the screen mode of the wide-screen TV to full mode. For details, refer to the instruction manual of your TV.

### **Notes on wide mode**

- When you record in 16:9 wide mode, the date and time indicator will be widened on the wide-screen TV.
- If you dub a tape, the tape is copied in the same mode as the original recording.
- When you set DIGITAL MODE to OVERLAP, the 16:9 WIDE setting is changed to OFF automatically.



# Photo recording

You can record a still picture like a photograph for about seven seconds. This mode is useful when you want to enjoy a picture such as a photograph or when you print a picture using a video printer (not supplied).

(1) Turn STANDBY up to PHOTO STANDBY.

PHOTO appears in the viewfinder.

(2) Keep pressing PHOTO lightly until a still picture appears in the viewfinder.

To change the still picture, release PHOTO, select a still picture again, and then press and hold PHOTO lightly. PHOTO CHAPTER appears in the viewfinder.

(3) Press PHOTO deeper.

The still picture in the viewfinder is recorded for about seven seconds. The sound during those seven seconds is also recorded. If you change the POWER switch or STANDBY to other positions while recording, this operation is performed after recording.

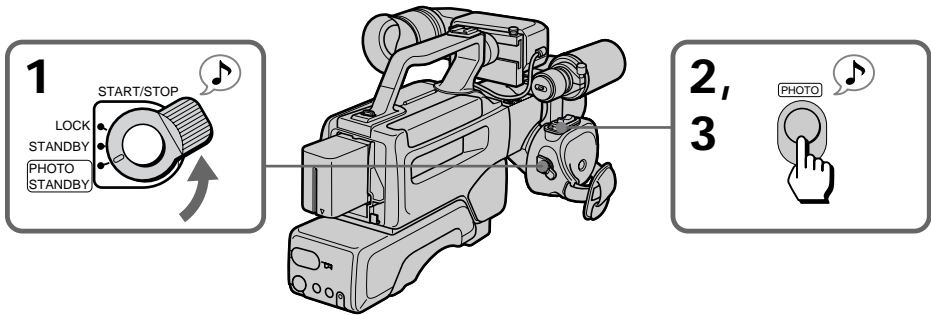

## To use the remote commander to take a photo

If you press the PHOTO button on the Remote Commander when a still picture appears in the viewfinder, the digital camcorder will record that still picture. However, you cannot select other still pictures by using this button.

## Note on automatic shutter speed adjustment

If AUTO LOCK is ON or AUTO/MANUAL is set to AUTO, the shutter speed is automatically adjusted up to 1/1000 depending on the environment.

## To use a flash

Attach the HVL-F7 video flash unit (not supplied) to the accessory shoe, and then connect a LANC cable to the  LANC jack.

## Note on using a flash

When using a flash, the shutter speed is automatically adjusted to 1/60 if using automatic adjustment, and if using manual adjustment, we recommend using a shutter speed of 1/60.

# Interval recording

You can make a time-lapse like recording by setting the digital camcorder to automatically record and standby sequentially. You can achieve an excellent recording for flowering, emergence, etc., with this function.

- (1) While the digital camcorder is in Standby mode, open the cover, then press MENU to display the menu in the viewfinder.
- (2) Press  $\downarrow$  or  $\uparrow$  to select INT REC, then press EXECUTE.
- (3) Press  $\downarrow$  or  $\uparrow$  to select SET, then press EXECUTE.
- (4) Press  $\downarrow$  or  $\uparrow$  to select ON, then press EXECUTE.
- (5) Press  $\downarrow$  or  $\uparrow$  to select INTERVAL, then press EXECUTE.
- (6) Press  $\downarrow$  or  $\uparrow$  to select the desired waiting time, then press EXECUTE.  
The time: 30SEC  $\leftrightarrow$  1MIN  $\leftrightarrow$  5MIN  $\leftrightarrow$  10MIN.
- (7) Press  $\downarrow$  or  $\uparrow$  to select REC TIME, then press EXECUTE.
- (8) Press  $\downarrow$  or  $\uparrow$  to select the desired recording time, then press EXECUTE.  
The time: 0.2SEC  $\leftrightarrow$  0.5SEC  $\leftrightarrow$  1SEC  $\leftrightarrow$  2SEC.
- (9) Press MENU to erase the menu display.  
You can also press  $\uparrow$  to select RETURN, then press EXECUTE to return to the menu display.
- (10) Press START/STOP to start interval recording.

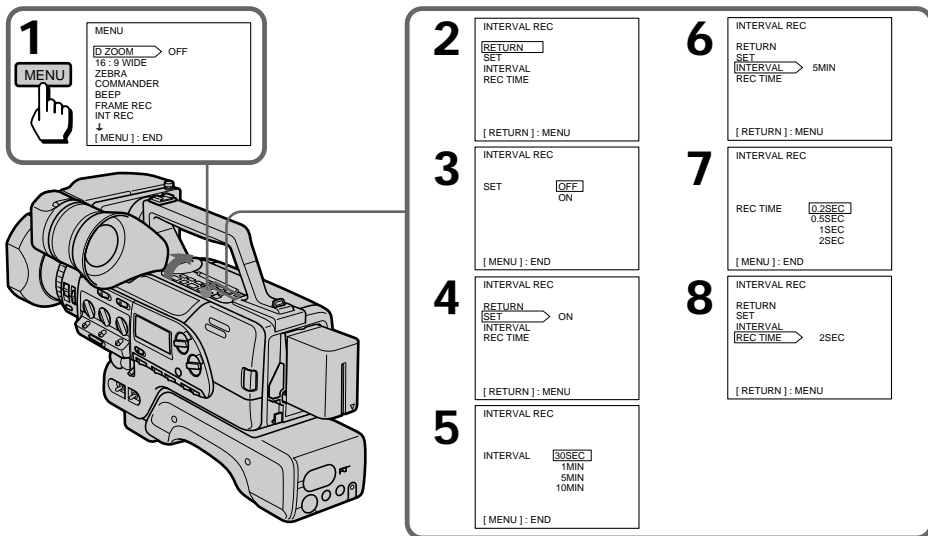

## To stop interval recording

Press START/STOP twice.

## To cancel interval recording

Set the INT REC mode to OFF in the menu system.

## Notes on interval recording

You cannot do interval recording with photo recording.

If you change the mode as follows, interval recording is cancelled

- Turn STANDBY down to LOCK.
- Set the POWER switch to OFF.
- Set CAMERA/VTR to VTR.

# Cut recording

You can make a recording with a stop-motion animated effect using cut recording. To create this effect, alternately move the subject a little and make a cut recording. Secure the digital camcorder and use the Remote Commander for effective cut recording.

- (1) While the digital camcorder is in Standby mode, open the cover, then press MENU to display the menu in the viewfinder.
- (2) Press  $\vee$  or  $\wedge$  to select FRAME REC, then press EXECUTE.
- (3) Press  $\vee$  or  $\wedge$  to select ON, then press EXECUTE.
- (4) Press MENU to erase the menu display.
- (5) Press START/STOP on the digital camcorder or the Remote Commander to start cut recording.  
The digital camcorder records about 6 frames, then enters recording Standby mode.
- (6) Move the subject, and repeat step 5.

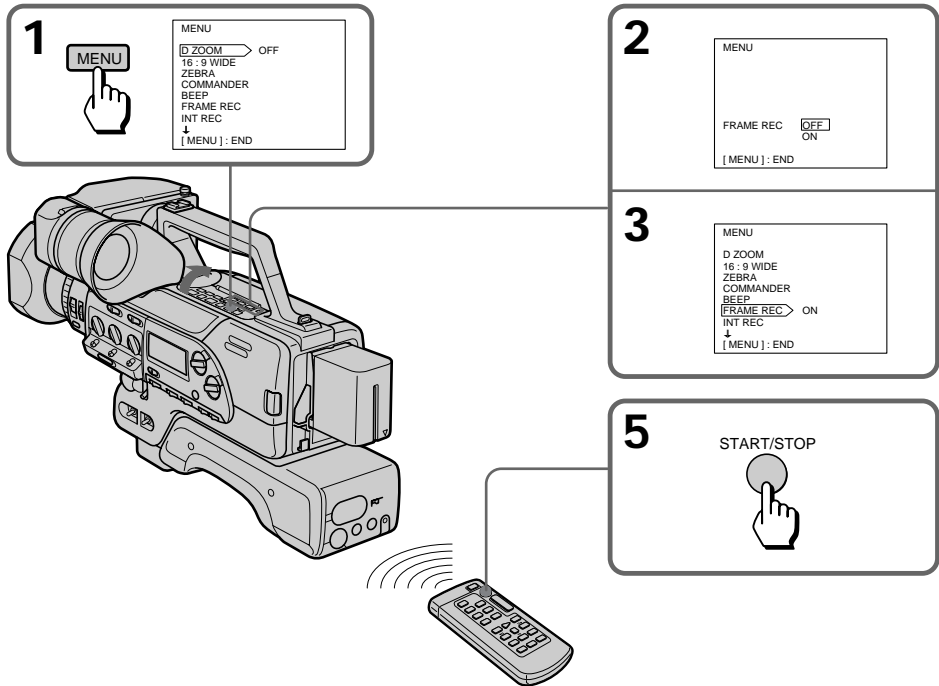

## To cancel cut recording

Set the FRAME REC mode to OFF in the menu system.

## Notes on cut recording

- The portion immediately after cut recording is completed may be longer than four frames.
- You cannot do cut recording with photo recording.
- The remaining tape indicator may not be accurate if you do cut recording repeatedly.

If you change the mode as follows, cut recording is cancelled

- Turn STANDBY down to LOCK.
- Set the POWER switch to OFF or CAMERA/VTR to VTR.

## Selecting automatic or manual mode

The digital camcorder's automatic functions offer you worry-free operation under most shooting conditions. But in some circumstances, manual adjustment is better for creative recording.

You can adjust focus, aperture, shutter speed, gain, and white balance automatically or manually.

Here's the overview of each manual adjustment. See the following pages for detailed information.

### **To focus manually**

Set FOCUS to MANU. You can adjust the focus regardless of the position of the AUTO LOCK switch. When you want to focus automatically, set FOCUS to AUTO.

### **To manually adjust aperture, shutter speed, gain, and white balance**

Set AUTO LOCK to OFF. By setting AUTO/MANUAL to MANUAL, you can adjust each item independently. When you want to adjust each item automatically, set AUTO/MANUAL to AUTO.

## When to adjust aperture, shutter speed, and gain manually

When selecting one of aperture, shutter speed, or gain to be adjusted manually and leaving the remaining two in automatic adjustment, the remaining two automatic settings adjust their values based on the value of that one manual setting. In the following cases, you should obtain better results by adjusting setting manually.

[a]



[b]



[c]



[a] Shooting portraits – adjust aperture manually.

To alter the depth of focus field, softening the background and making the subject stand out, portrait style.

[b] Shooting sporting events – adjust shutter speed manually.

- To record fast moving objects and protect against blurring of subject.
- To brighten subject in dark situations.
- To prevent the aperture from closing down in unusually bright situations.

[c] Shooting dark environments – adjust gain manually.

- To suppress color distortion when shooting bright objects in dark places.
- To protect against picture distortion when shooting bright objects.

### Settings for each item

Item	Selectable steps	Variation of exposure	Brighter ↔ Darker
Aperture	13 steps	0.5 EV/step	F1.6 ↔ F11, CLOSE
Shutter speed	12 steps	1 – 2 EV/step	1/4 ↔ 1/10000
Gain	8 steps	0.5 EV/step	+18 dB ↔ -3dB

### Notes on recording in manual mode

- We recommend that you adjust the focus and white balance manually.
- Depending on the shutter speed, a screen may flicker and a color of screen may change when you record under the illumination by a discharge tube such as a fluorescent lamp, a sodium light and a mercury lamp. In such a case, fix shutter speed in 1/100 in an area of 50 Hz and in 1/60 in an area of 60 Hz.

## Relation of aperture, shutter speed and gain

While recording, a picture's brightness varies by exposure, you need to keep the exposure fixed to obtain a fixed brightness.

$$\begin{aligned} \text{Total EV (exposure)} &= \text{EV from aperture control} \\ &\quad + \text{EV from shutter speed control} \\ &\quad + \text{EV from gain control} \end{aligned}$$

# Focusing manually

## When to use manual focus

In the following cases you should obtain better results by adjusting the focus manually.

[a]



[b]

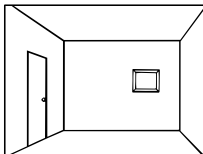

[c]

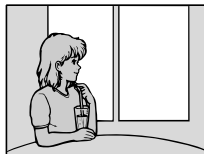

[d]

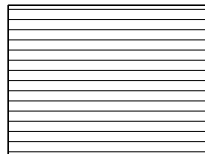

- Insufficient light [a]
- Subjects with little contrast - walls, sky, etc. [b]
- Too much brightness behind the subject [c]
- Horizontal stripes [d]
- Subjects through frosted glass
- Subjects beyond nets, etc.
- Bright subject or subject reflecting the light
- Shooting a stationary subject when using a tripod

## Focusing manually

When focusing manually, first focus in telephoto before recording, and then reset the shot length.

- (1) Set FOCUS to MANU. The  $\infty$  indicator appears in the viewfinder.
- (2) Press the power zoom button on the "T" side so that the bar in the viewfinder moves all the way to the "T" side.
- (3) Turn the focus ring to achieve a sharp focus.
- (4) Set the desired shot length using the power zoom button.

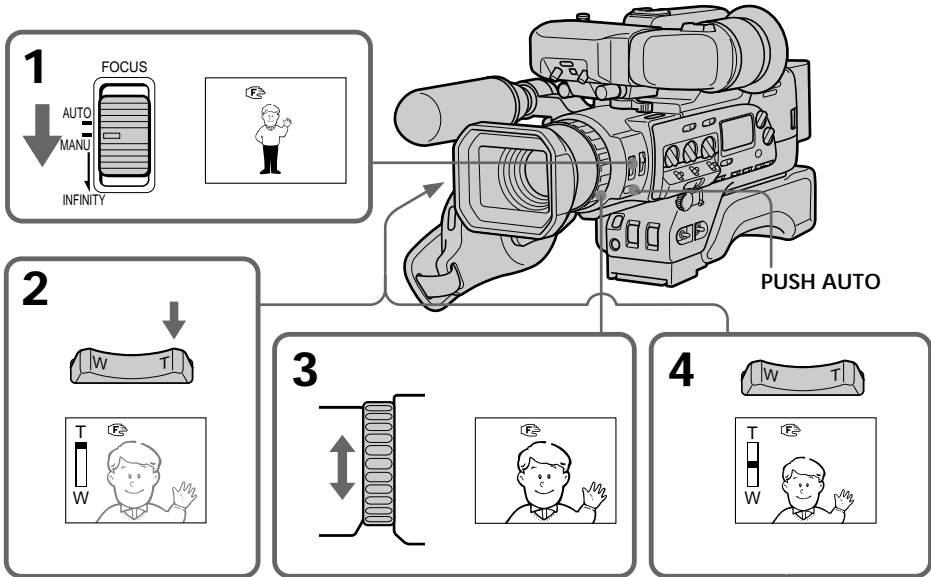

### Shooting with auto focusing momentarily

Press PUSH AUTO while focusing manually.

Auto focus functions while you are pressing PUSH AUTO.

When you release PUSH AUTO, manual focusing returns.

You can use this feature to switch between two subjects cleanly.

### To return to autofocus mode

Set FOCUS to AUTO. The  indicator in the viewfinder disappears.

### Shooting in relatively dark places

Shoot at wide-angle after focusing in the telephoto position.

### Shooting fast-moving subjects in relatively bright places

Shoot at wide-angle.



### To record a very distant subject

Push FOCUS down to INFINITY. The lens focuses on the most distant subject while FOCUS is held down. When it is released, manual focus mode is resumed.

Use this function when shooting through a window or a screen, to focus on a most distant subject.

### Notes on manual focusing

The following indicators may appear:

-  when recording a very distant subject.
-  when the subject is too close to focus on.

### When you shoot close to the subject

Shoot at wide-angle.



# Adjusting the aperture

If the difference between the brightness of the subject and the background is too great, adjust the aperture manually.

When the aperture opens (lowering the F value), focal point becomes smaller (reducing depth of field) so that the background will blur and the subject will be in focus [a].

When the aperture closes (raising the F value), focal point becomes greater (increasing depth of field) so that both background and subject will focus clearly [b].

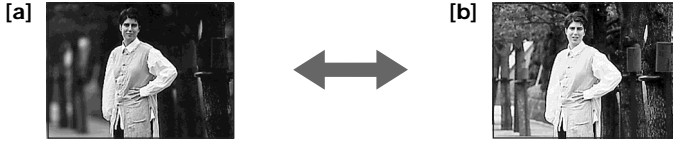

(1) Set AUTO LOCK to OFF.

(2) Set AUTO/MANUAL to the right of the IRIS dial to MANUAL.  
The current aperture setting appears in the viewfinder.

(3) Turn IRIS to adjust the aperture.

Using the dial, you can select F1.6, F2, F2.4, F2.8, F3.4, F4, F4.8, F5.6, F6.8, F8, F9.6, F11, and CLOSE. The aperture indicator appears in the viewfinder.

If you select CLOSE, the aperture closes completely, and the picture becomes black (the effect is the same as trying to record with the lens cover attached).

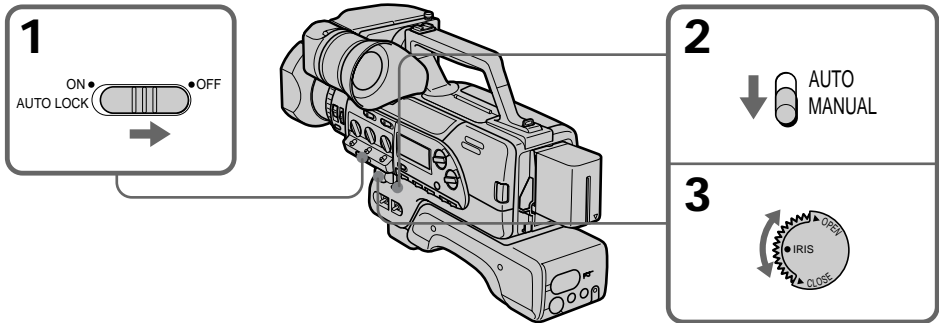

## To return to automatic aperture mode

Set AUTO/MANUAL at the right of the IRIS dial to AUTO.

## About the depth of focus field

The depth of focus field is the in-focus range measured from the distance behind a subject to the distance in front. The depth of focus field can vary with the aperture value and the focal length. Lowering the F value (larger aperture) reduces the depth of focus field. Raising the F value (smaller aperture) provides a larger depth of focus field. Zooming in telephoto position offers a smaller depth of focus field while the depth of focus field in wide-angle position is greater.

## Note on the aperture

When zoom is in telephoto, you can open the aperture as far as F2 (not to F1.6).

# Adjusting the shutter speed

Adjust the shutter speed to control the picture quality. When recording sports events, for example, use a high speed shutter to record fast moving objects clearly.

You can select from 6 different shutter speeds SLOW, 60, 100, 250, 1000 and PRESET. SLOW and PRESET have their own menus. Refer to “To adjust the SLOW SHTR (shutter) or S (shutter) PRESET menu items”.

Shutter speed numbers that appear in the viewfinder are inverted. For example, “250” means 1/250 sec.

- (1) Set AUTO LOCK to OFF.
- (2) Set AUTO/MANUAL under the SHUTTER SPEED dial to MANUAL.
- (3) Turn SHUTTER SPEED to select a shutter speed. Using the dial, you can select SLOW, 60, 100, 250, or PRESET. The shutter speed indicator appears in the viewfinder screen.

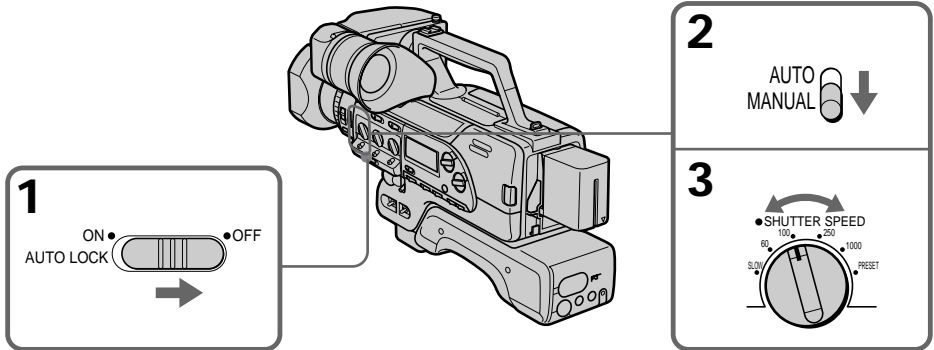

## To return to automatic shutter speed mode

Set AUTO/MANUAL under the SHUTTER SPEED dial to AUTO.

## To adjust the SLOW SHTR (shutter) or S (shutter) PRESET menu items

When you want to make a dark scene look brighter or give an object the appearance of motion, use a slow shutter. Select speed from the SLOW SHTR menu.

When you want to choose a shutter, select the appropriate shutter speed from the S PRESET menu.

The chosen speed data is set into memory. When you dial another setting, (e.g. 100), then return to SLOW or PRESET, the previous speed is selected automatically.

- (1) Open the cover, then press MENU to display the menu.
- (2) Press  $\vee$  or  $\wedge$  to select SLOW SHTR or S PRESET, then press EXECUTE.
- (3) Press  $\vee$  or  $\wedge$  to select a setting, then press EXECUTE.

You can select the following shutter speeds:

SLOW SHTR - 4, 8, 15, 30.

S PRESET - 60, 100, 250, 500, 1000, 2000, 4000, 10000.

- (4) Press MENU to erase the menu display.

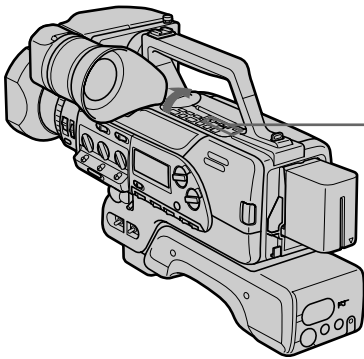

<b>2</b>	<b>SLOW SHTR</b>	<b>S PRESET</b>
	<div style="border: 1px solid black; padding: 5px;">           MENU             4            8            15            30             SLOW SHTR             [ MENU ] : END         </div>	<div style="border: 1px solid black; padding: 5px;">           MENU             ↑            500            1000            2000            4000            10000             S PRESET             [ MENU ] : END         </div>
<b>3</b>	<div style="border: 1px solid black; padding: 5px;">           MENU            ↑            ZEBRA            COMMANDER            BEEP            FRAME REC            INT REC            SLOW SHTR → 4            S PRESET            ↓            [ MENU ] : END         </div>	<div style="border: 1px solid black; padding: 5px;">           MENU            ↑            COMMANDER            BEEP            FRAME REC            INT REC            SLOW SHTR            S PRESET → 500            G PRESET            ↓            [ MENU ] : END         </div>

## Adjusting the shutter speed

### To select the Best Shutter Speed

Concerning shooting conditions and brightness, refer to the following chart to adjust shutter speed accordingly.

Subject	Shutter speed
<ul style="list-style-type: none"><li>• A golf swing or tennis match in fine weather</li></ul>	1/500 – 1/10000
<ul style="list-style-type: none"><li>• A landscape shot from a moving car or train</li><li>• A moving roller coaster in overcast days</li><li>• An athletic scene, marathon, etc.</li></ul>	1/100 – 1/500
<ul style="list-style-type: none"><li>• Indoor sports</li><li>• Replacement for the ND2 filter (to halve the exposure) in situations of glare a sunny beach or a snow covered mountain.</li><li>• Recording pictures with less flicker under a fluorescent lamp</li><li>• In sunny weather (to avoid an out-of-focus picture due to a small aperture)</li></ul>	1/100

#### Notes on the slow shutter speed

- You cannot use the slow shutter when DIGITAL MODE is set to OVERLAP.
- When using slow shutter, focusing can become difficult. In this case set focus to manual and put the digital camcorder on a tripod.

#### Notes on the high shutter speed

- Using high shutter speed can cause the image to darken. So check brightness using the viewfinder.
- Depending on the shutter speed, a screen may flicker and a color of screen may change when you record under the illumination by a discharge tube such as a fluorescent lamp, a sodium light and a mercury lamp. In such a case, fix shutter speed in 1/100 in an area of 50 Hz and in 1/60 in an area of 60 Hz.

# Adjusting the gain

If the picture is too dark even with the aperture fully open, and using the slowest acceptable shutter speed, adjust the gain to make the picture as bright as necessary. When shooting night scenes in automatic setting, the picture may become dark. To brighten the picture, the digital camcorder will automatically turn the gain value up, and picture noise can develop. In this case, adjust the gain in accordance with the atmosphere of the subject.



- (1) Set AUTO LOCK to OFF.
- (2) Set AUTO/MANUAL under the GAIN dial to MANUAL.
- (3) Turn GAIN to adjust the gain.

Using the dial, you can select -3, 0, 3, 6, 9, or PRESET. The gain indicator appears in the viewfinder.

If you turn the dial to PRESET (preset gain), the setting you selected in the menu activates.

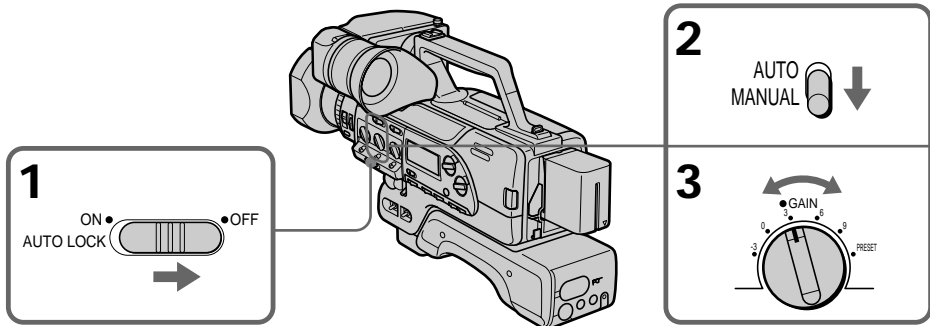

## To return to automatic gain mode

Set AUTO/MANUAL under the GAIN dial to AUTO.

## Adjusting the gain

### To adjust the G (gain) PRESET menu item

When you want to choose a gain setting higher than 9, select the appropriate level from the G PRESET menu.

The setting data is set into memory. When you dial another setting, (e.g. 9), then return to PRESET, the previous setting is selected automatically.

- (1) Open the cover, then press MENU to display the menu.
- (2) Press  $\vee$  or  $\wedge$  to select G PRESET, then press EXECUTE.
- (3) Press  $\vee$  or  $\wedge$  to select a setting, then press EXECUTE.

You can select the following settings: -3, 0, 3, 6, 9, 12, 15, 18 dB.

- (4) Press MENU to erase the menu display.

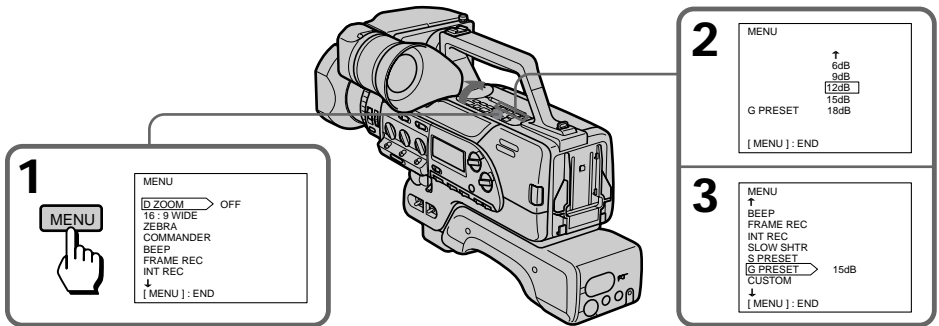

### Note on the gain

If you set gain too high, picture noise results.

# Adjusting the white balance

White balance is the adjustment to make white subjects look white and to obtain a more natural color balance. You can obtain better results by adjusting the white balance manually when lighting conditions change quickly or when recording outdoors, e.g. neon signs, fireworks.

## Selecting the appropriate mode

[a]



[b]



[c]



[d]



### one-push white balance mode

- Shooting with lighting condition on the subject set and with the white balance set in a particular condition
- Monochromatic subject or background [a]

### indoor mode

- Lighting conditions change quickly [b]
- A bright place such as a photography studio
- Under sodium or mercury lamps



### outdoor mode

- Under a color matching fluorescent lamp
- Recording a sunset/sunrise, just after sunset, just before sunrise [c], neon signs, or fireworks [d]

## Adjusting the white balance

### Adjusting white balance manually

- (1) Set AUTO LOCK to OFF.
- (2) Set AUTO/MANUAL under the WHT BAL dial to MANUAL.
- (3) Turn WHT BAL to select a white balance.

Usually select  (indoor mode) or  (outdoor mode). To fix the white balance by using one-push white balance, select  and see “Locking the white balance setting”.

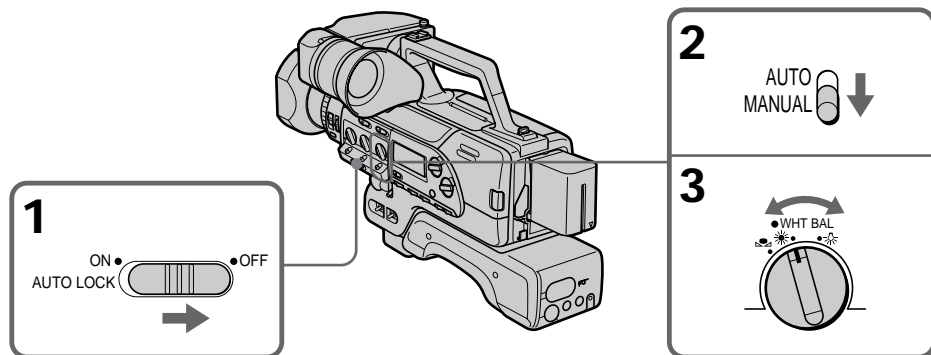





### To return to automatic white balance mode

Set AUTO/MANUAL under the WHT BAL dial to AUTO.

### Locking the white balance setting (One-push white balance mode)

When you set the white balance to one-push white balance mode, the setting is locked and maintained even if lighting conditions change. In addition, if the lithium battery is installed, the setting is saved for one hour if you remove the power source.

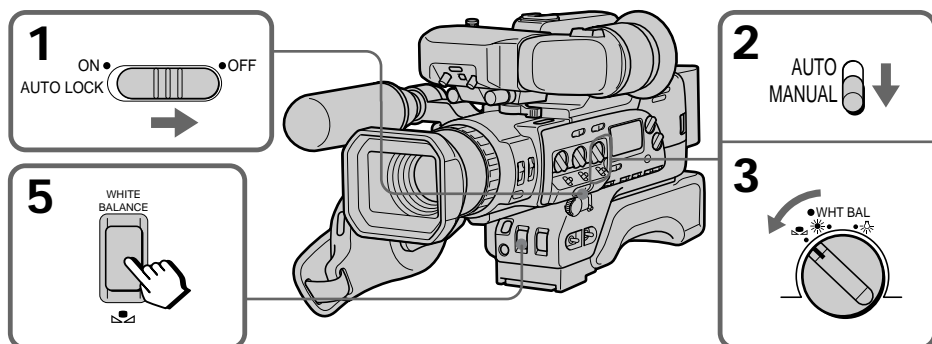

- (1) While in Standby mode, set AUTO LOCK to OFF.
- (2) Set AUTO/MANUAL under the WHT BAL dial to MANUAL.
- (3) Turn WHT BAL to . The  indicator appears in viewfinder.
- (4) Shoot a white object, such as paper, fully in the viewfinder.
- (5) Press WHITE BALANCE  on the front of the digital camcorder.

The  indicator flashes rapidly. When the white balance has been adjusted and stored in memory, the indicator stops flashing.







### Notes on the indicator in the viewfinder

- The indicator means:
  - Slow flashing: white balance is not adjusted
  - Fast flashing: white balance is being adjusted (after you pressed WHITE BALANCE )
  - Lit steady: white balance has been adjusted.
- If the  indicator keeps flashing even when you press WHITE BALANCE , shoot in automatic white balance mode. Set AUTO LOCK to ON and slide AUTO/MANUAL under the WHT BAL dial to AUTO.

### Notes on white balance

- When you shoot with studio lighting or video lighting, use  (indoor) mode.
- When you shoot under fluorescent lighting, use automatic white balance mode.

### Shooting when the lighting condition changes

- After the lighting condition changes, readjust the white balance using the WHITE BALANCE  button while the digital camcorder is in Standby mode. The WHITE BALANCE  button does not function during recording.
- If you are adjusting the aperture (iris) and shutter speed manually, then when you move from indoors to outdoors or vice-versa, set AUTO LOCK to ON and then set it to OFF again.
- After you move from indoors to outdoors or vice-versa, or detach the battery to replace it, while shooting in automatic white balance mode, point the digital camcorder at a white subject for about 10 seconds before you start recording.

# Using the ND filter

The digital camcorder automatically senses the need for the ND filter, in such a case, ND ON/OFF flashes in the display.

Using the ND filter (to filter down to one-tenth the quantity of light), you can prevent the picture from going out of focus under bright conditions.

## When ND ON flashes in the viewfinder

Set ND FILTER to ON [a].

The flashing indicator disappears, and the ND indicator remains.

## When ND OFF flashes in the viewfinder

Set ND FILTER to OFF [b].

The indicator disappears.

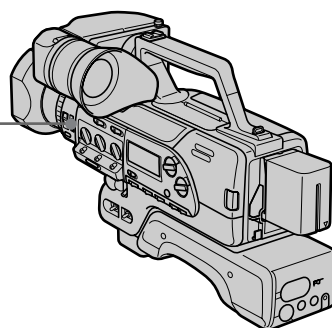
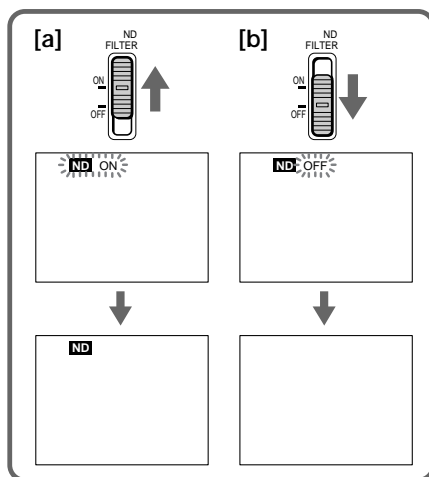

# Using the zebra pattern

You can set the digital camcorder to display a zebra pattern (diagonal stripes) [a] in the portion of the picture in the viewfinder where the brightness exceeds a certain level. The portion of the picture where the zebra pattern appears is an area of high brightness and overexposure. You can check the picture level of a subject by displaying the zebra pattern.

Before you start recording, use the zebra pattern as a guide for adjusting the aperture, gain, and shutter speed.

- (1) Open the cover, then press MENU to display the menu in the viewfinder.
- (2) Press  $\downarrow$  or  $\uparrow$  to select ZEBRA, then press EXECUTE.
- (3) Press  $\downarrow$  or  $\uparrow$  to select ON, then press EXECUTE.
- (4) Press MENU to erase the menu display.



[a]

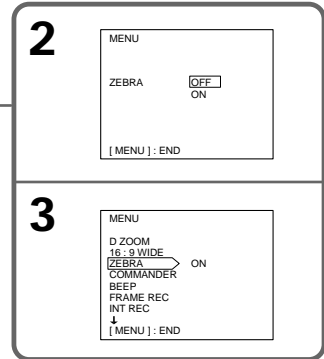
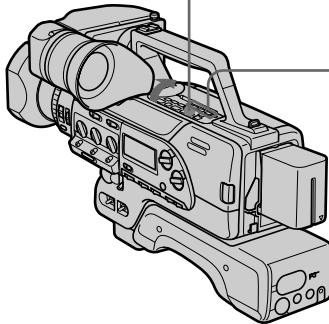
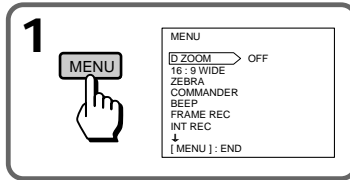

## Note on shooting with the zebra pattern

Even though you see the zebra pattern in the viewfinder, the zebra pattern is not recorded.

# Adjusting the recording sound

You can adjust the recording sound level. Use headphones (not supplied) to monitor the sound when you adjust.

## Checking the recording level

Use the level indicator in the display window. If the input level is excessive, the PEAK indicator lights. If the PEAK indicator remains lit, adjust the recording sound manually.

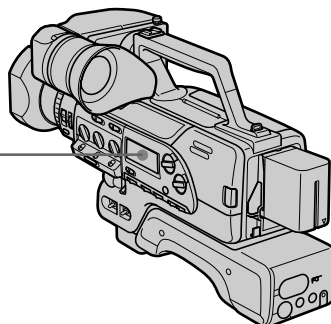
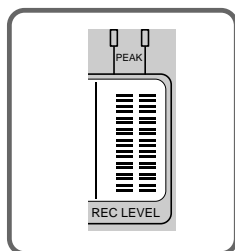

## Adjusting the recording level automatically

Set the REC LEVEL switch to AUTO.

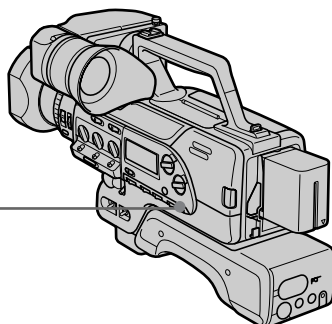
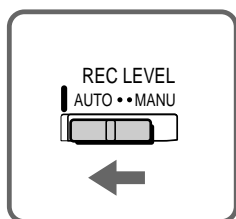

## Adjusting the recording level manually

- (1) Set the REC LEVEL switch to MANU.
  - (2) Turn REC LEVEL to adjust the sound level so that the PEAK indicator does not light up. You can adjust the level of each channel separately.
- We recommend using headphones (not supplied) to monitor the sound when you adjust.  
You can use AUDIO MONITOR to monitor the L, R, or stereo sound.

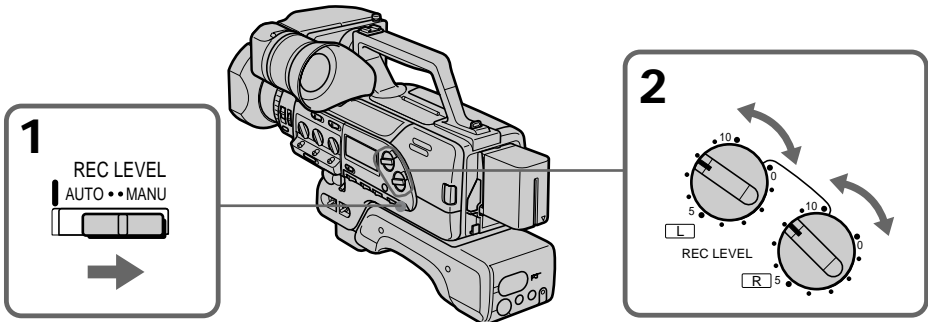

### To attenuate the recording level

Set the MIC switch to ATT.

- Normally set to off (green position)
- When recording very loud sounds, set to ATT

### To reduce wind noise of the built-in microphone

If there is a loud wind, set the BUILT-IN MIC switch to WIND, however, low frequency input signal will weaken.

### To change the directionality of the built-in microphone

Set DIRECTION SELECT to the desired position (0°/90°/120°).

When set to 0° the sound is in monaural.

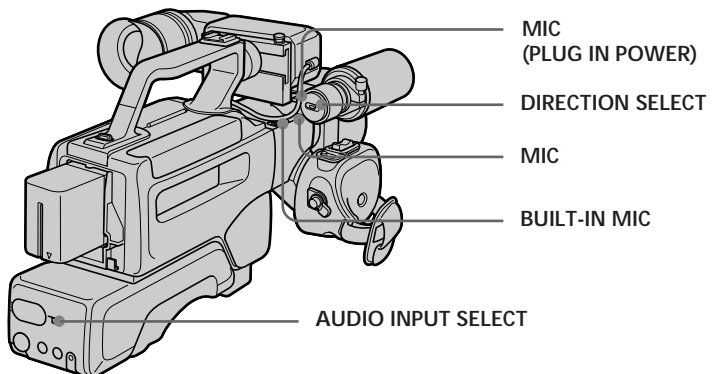

## Adjusting the recording sound

### To use external microphone

You can record narration using an external microphone.

Set AUDIO INPUT SELECT to MIC.

Set MIC SELECT to NORM so that you can record with an external microphone but the built-in microphone will be disabled.

Set MIC SELECT to DUAL so that the external microphone records on the L channel and the built-in microphone records on the R channel. Respectively, the sound is in monaural.

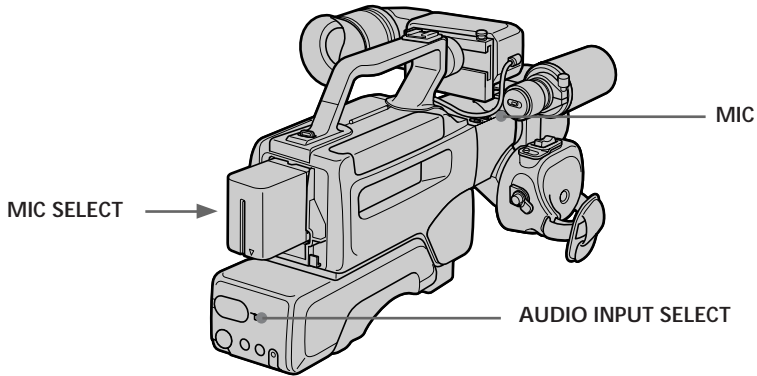

# Releasing the STEADY SHOT function

When you shoot, the (👉) indicator appears in the viewfinder. This indicates that the Steady Shot function is working and the digital camcorder compensates for camera-shake.

When you attach the digital camcorder to a tripod, you need not worry about camera-shake.

Release the Steady Shot function.

Set STEADY SHOT to OFF.

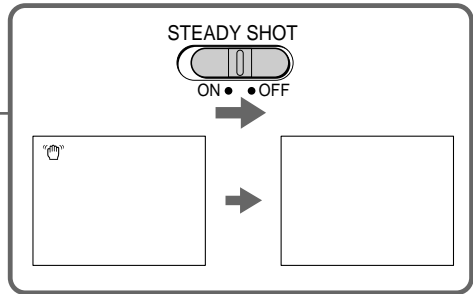
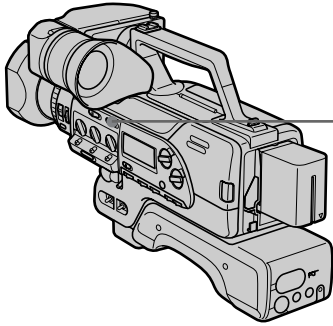

## To activate the Steady Shot function again

Set STEADY SHOT to ON.

### Note on the Steady Shot function

The Steady Shot function will not correct excessive camera-shake.

# Making a custom preset

Use this menu setting to achieve consistent picture quality. This feature lets you customize the picture quality.

Item	Adjusts	Adjustment value
COLOR LEV	Color intensity	Decreases color intensity ↔ Increases color intensity
SHARPNESS	Sharpness	Softer ↔ Sharper
WB SHIFT	White balance	Bluish ↔ Reddish
AE SHIFT*	Brightness	Darker ↔ Brighter

\* When the aperture, shutter speed and gain are set manually, AE SHIFT level does not change.

- (1) Open the cover, then press MENU to display the menu in the viewfinder.
- (2) Press  $\vee$  or  $\wedge$  to select CUSTOM, then press EXECUTE.  
The custom preset menu appears.
- (3) Press  $\vee$  to select SET, then press EXECUTE.
- (4) Press  $\vee$  to select ON, then press EXECUTE.
- (5) Press  $\vee$  or  $\wedge$  to select the desired item, then press EXECUTE.
- (6) Press  $\vee$  or  $\wedge$  to adjust the selected mode, then press EXECUTE.
- (7) Press MENU to erase the menu display and display  $\square$  in the viewfinder.  
To perform other menu settings, press  $\wedge$  to select RETURN, then press EXECUTE.

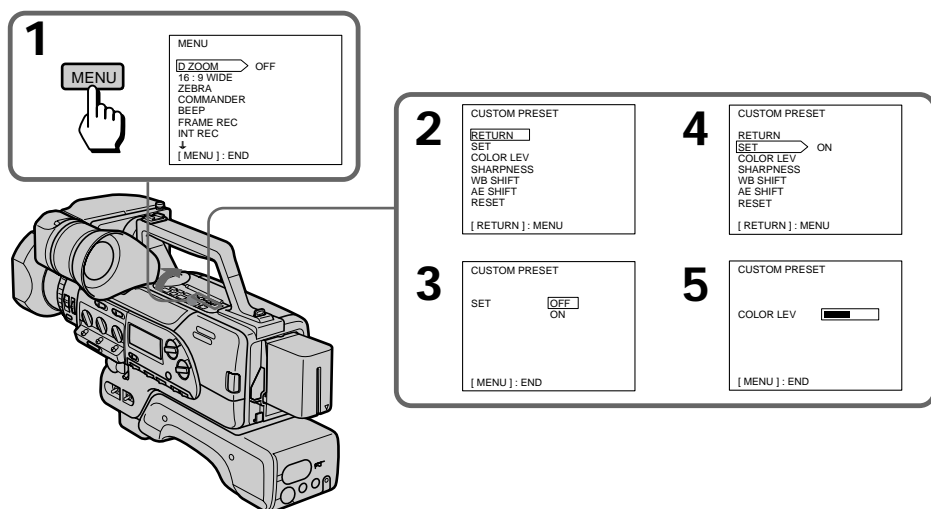



**To turn off custom preset**

- (1) While the digital camcorder is in Standby mode, press MENU.
- (2) Press  $\blacktriangledown$  or  $\blacktriangle$  to select CUSTOM, then press EXECUTE.
- (3) Press  $\blacktriangledown$  to select SET, then press EXECUTE.
- (4) Press  $\blacktriangledown$  to select OFF, then press EXECUTE.  
CP goes off in the viewfinder.
- (5) Press MENU to erase the menu display.

**To turn on custom preset again**

- (1) While the digital camcorder is in Standby mode, press MENU.
- (2) Press  $\blacktriangledown$  or  $\blacktriangle$  to select CUSTOM, then press EXECUTE.
- (3) Press  $\blacktriangledown$  to select SET, then press EXECUTE.
- (4) Press  $\blacktriangledown$  to select ON, then press EXECUTE.
- (5) Press MENU to display CP in the viewfinder.

**To restore the standard settings**

- (1) While the digital camcorder is in Standby mode, press MENU.
- (2) Press  $\blacktriangledown$  or  $\blacktriangle$  to select CUSTOM, then press EXECUTE.
- (3) Press  $\blacktriangledown$  to select RESET, then press EXECUTE.  
FINISHED appears in the viewfinder
- (4) Press MENU to erase the menu display.

**To check the custom preset settings**

You can display and check the custom preset settings in the viewfinder while recording. Press CP CHECK on the front of the digital camcorder while the digital camcorder is in Standby mode or recording mode.

The custom preset settings are displayed in the viewfinder.  
Press CP CHECK again to make the display disappear.

**Note on custom preset**

You can turn on custom preset when in automatic mode and also when in manual mode.

# Re-recording a picture in the middle of a recorded tape

You can insert a scene in the middle of a recorded tape by setting the starting and ending points. The previous recorded portion will be erased.

- (1) While the digital camcorder is in Standby mode, keep pressing the + (forward playback) or - (reverse playback) side of EDITSEARCH, and release the button where you want to end the insertion [b]. The digital camcorder enters Standby mode again.
- (2) Press ZERO SET MEMORY.  
The counter is reset to "0:00:00".  
"ZERO SET MEMORY" flashes and the ending point is stored in memory.
- (3) Hold down the - side of EDITSEARCH until the digital camcorder goes back to the point where you want to start the insertion [a].
- (4) Press START/STOP to start re-recording. The insert recording stops automatically at the counter zero point, and the digital camcorder enters Standby mode again. Zero set memory resumes automatically.

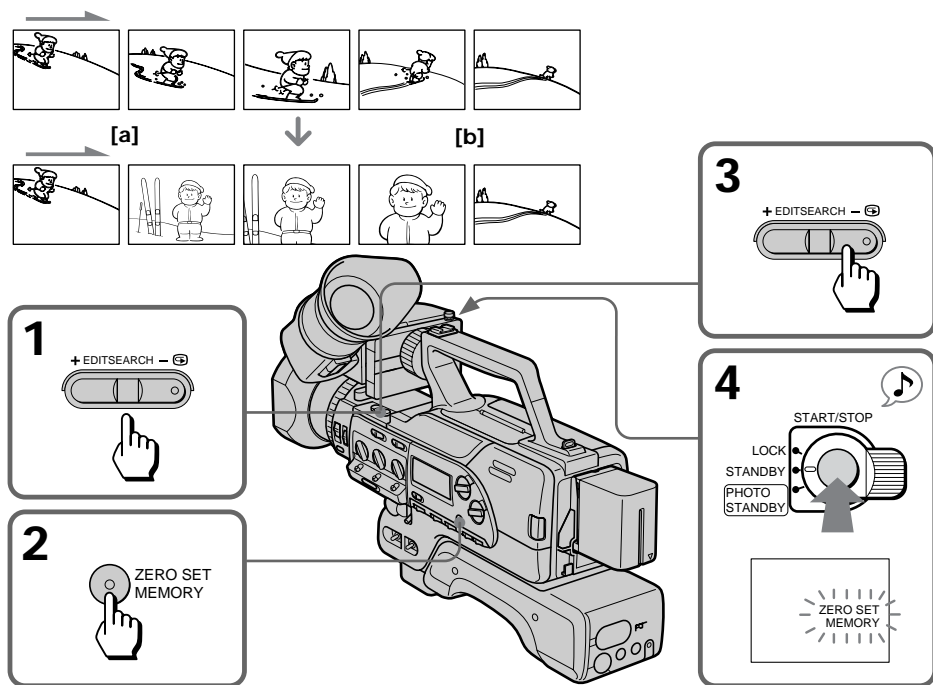

## To change the end point

Press ZERO SET MEMORY so that "ZERO SET MEMORY" disappears.  
Repeat steps 1 to 3.

### Notes on editsearch

- The picture may be distorted at the end of the inserted portion when it is played back.
- Zero set memory may not function when there is a blank portion between pictures on a tape.
- You can re-record without using the zero set memory. Skip steps 1 and 2. Press START/STOP to stop recording.

# Searching the recorded picture

When you use a cassette memory-mounted DV cassette (CIII logo\*) which can store the recorded date and time, etc., you can search the recorded picture with the date or time using the Remote Commander (Cassette memory search). You can also search the photo-recorded pictures only, or the recorded picture in the backward and forward direction from the present position without cassette memory.

\*CIII is a trademark.

## Searching the recorded picture with the date or time - Cassette memory search

- (1) Set the POWER switch to ON, then set CAMERA/VTR to VTR.
- (2) Open the cover, press MENU to display the menu in the viewfinder.
- (3) Set CM SEARCH to ON in the menu system.
- (4) Press MENU to erase the menu display.
- (5) Press SEARCH MODE on the Remote Commander to select date search (search with the date) or photo search (search the photo recorded-pictures only).
- (6) On the Remote Commander, press ►► to search forward or ◀◀ to search backward.

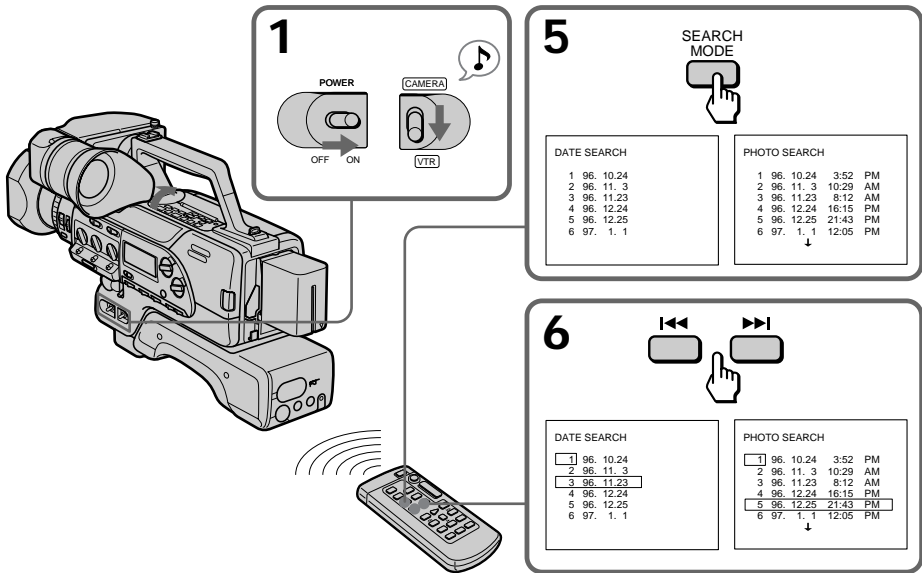

## Searching the recorded picture

### Notes on cassette memory search

- You can search up to 6 days for date search and 43 pictures for photo search when you use the 4k-bit cassette memory.
- Make sure that the lithium battery is installed if using cassette memory.

## Searching the recorded picture without using cassette memory

- (1) Set the POWER switch to ON, then set CAMERA/VTR to VTR.
- (2) Open the cover, press MENU to display the menu in the viewfinder.
- (3) Set CM SEARCH to OFF in the menu system.
- (4) Press MENU to erase the menu display.
- (5) Press SEARCH MODE on the Remote Commander to select date search (search with the date) or photo search (search the photo-recorded pictures only).
- (6) On the Remote Commander, press ►► to search forward or ◄◄ to search backward.  
Each time you press ►► or ◄◄, the digital camcorder searches for the next scene.

### To stop searching

Press □.

### If your tape has blank portions between pictures

The digital camcorder may not search for the recorded picture or data may not be stored.

### Notes on searching

- The digital camcorder may not search correctly if the beginning of the search portion is too close to the tape head position.
- When you use date search, the digital camcorder plays back the search picture, and when you use photo search, the digital camcorder enters playback pause when it finds the point it was searching for.

# Displaying recording data

You can display the recording data (date/time or various setting when recorded) when you recorded (**Data Code**), on the TV during playback or editing. The Data Code is also displayed in the viewfinder and the display window.

Press **DATA CODE** on the Remote Commander while playing back. Each time you press **DATA CODE**, the indicator cycles in the viewfinder as follows:

When you select **DATE/CAM** from the menu **[a]**:  
recorded date and time → various settings → no indication

When you select **DATE** from the menu **[b]**:  
recorded date and time → no indication

Press **DATA CODE** repeatedly to erase the display.

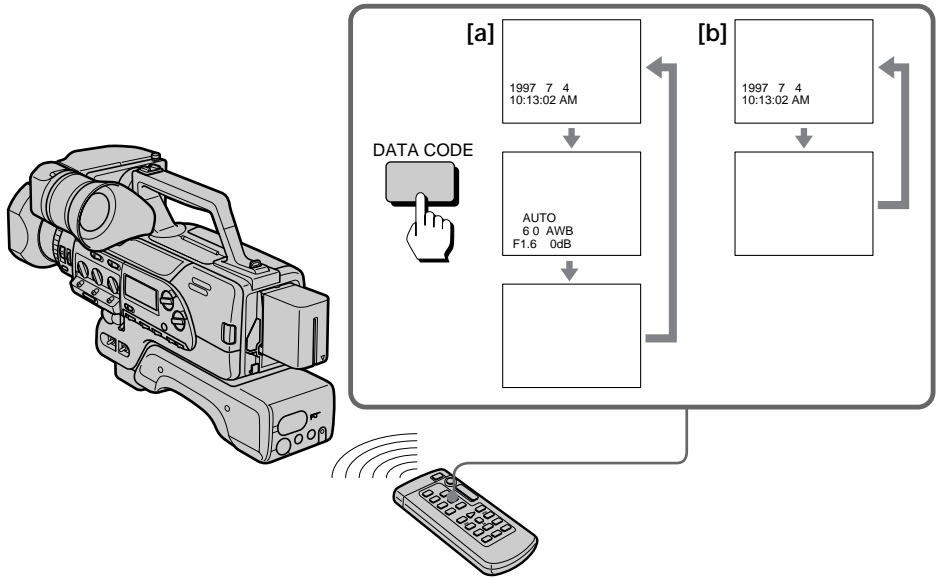

## When bars (---:---) appear

- A blank portion of the tape is being played back.
- The tape was recorded by a digital camcorder without the Data Code function.
- The tape was recorded by a digital camcorder without having date and time set.

# Editing onto another tape

You can create your own video program by editing with any other DV, <sup>Mini</sup>**DV** mini DV, **8** 8 mm, **Hi8** Hi8, **VHS** VHS, **S-VHS** S-VHS, **VHS-C** VHSC, **S-VHS-C** S-VHSC, or **B** Betamax VCR that has video/audio inputs.

You can edit with little deterioration of picture and sound quality when using the DV connecting cable (not supplied).

## Before editing

Connect the digital camcorder to the VCR using the supplied A/V connecting cable or the VMC-2DV connecting cable (not supplied).

### To use the A/V connecting cable

Set the input selector on the VCR to LINE.

### If your VCR is a monaural type

Connect only the white plug for audio on both the digital camcorder and the VCR.

With this connection, the sound is monaural.

### To use the DV connecting cable

Simply connect the DV connecting cable to DV IN/OUT of the digital camcorder and DV products to DV IN of DV products.

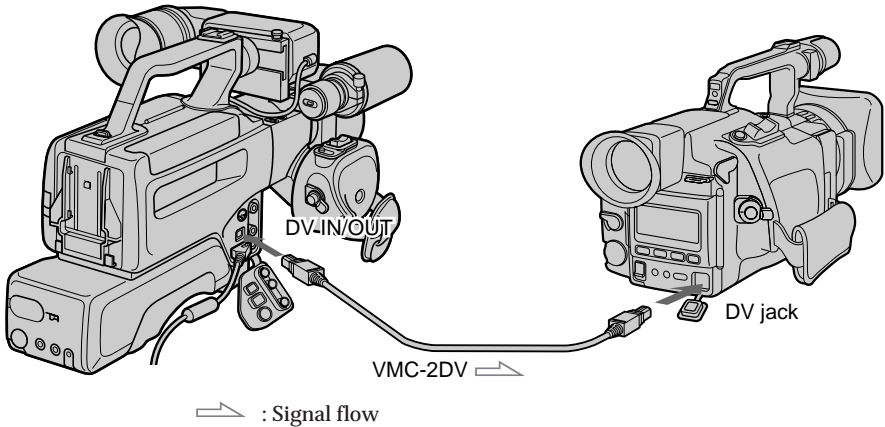

**Notes on editing when using the DV connecting cable**

- You can connect one VCR only.
- Connect the  LANC jacks when controlling this digital camcorder from another VCR for editing.
- If you recorded the playback pauses picture via the DV jack, the recorded picture becomes rough.
- You can use this digital camcorder as a recorder.  
In this case, you do not need to change the DV connecting cable's connection since the direction of signal flow changes automatically, make sure that "DV IN" appears on the TV and/or in the viewfinder.

**When you use this digital camcorder as a recorder**

Cassette memory data is not recorded.

**Starting editing**

- (1) Set the POWER switch to ON and then set CAMERA/VTR to VTR.
- (2) Insert a blank tape (or a tape you want to record over) into the recording VCR.  
Then insert your recorded tape into the digital camcorder.
- (3) Play back the recorded tape on the digital camcorder until you locate the point where you want to start editing. Then set the digital camcorder to playback pause mode.
- (4) Set the recording VCR to recording pause mode.
- (5) Press **II** on the digital camcorder and VCR simultaneously to start editing.

**To edit more scenes**

Repeat steps 3 to 5.

**To stop editing**

Press  on the digital camcorder and VCR.

**Note on editing when using the A/V connecting cable**

Press DISPLAY on the Remote Commander while editing onto another tape to turn off the display indicators. Otherwise, the indicators will be recorded on the tape.

**Note on Fine Synchro Edit**

If you connect a VCR that has the Fine Synchro Edit feature to the  LANC jack of the digital camcorder using a LANC cable (not supplied), the edit will be even more precise.

# Replacing recording on a tape

You can insert a new picture, sound, recording data/time, camera information, etc., from a VCR onto your already recorded tape by specifying the starting and ending points.

Connection is the same as in “To use the DV connecting cable” on page 62.

- (1) Set the POWER switch to ON and then set CAMERA/VTR to VTR.
- (2) On the VCR, search for the start point to be inserted for playback, then set it to playback pause mode.
- (3) On the digital camcorder, search for the point where you want to end insert editing, then set it to playback pause mode.  
It is convenient to use EDITSEARCH.
- (4) Press ZERO SET MEMORY.  
The counter is reset to zero (0:00:00).  
“ZERO SET MEMORY” flashes and the ending point is stored in memory.
- (5) On the digital camcorder, search for the point where you want to start editing, then set it to playback pause mode.
- (6) Set the digital camcorder to recording pause mode.
- (7) Press **II** on the digital camcorder and VCR simultaneously to start editing.  
The editing starts and the new scene is inserted on the recorded tape. The editing stops automatically near the counter zero point (0:00:00).

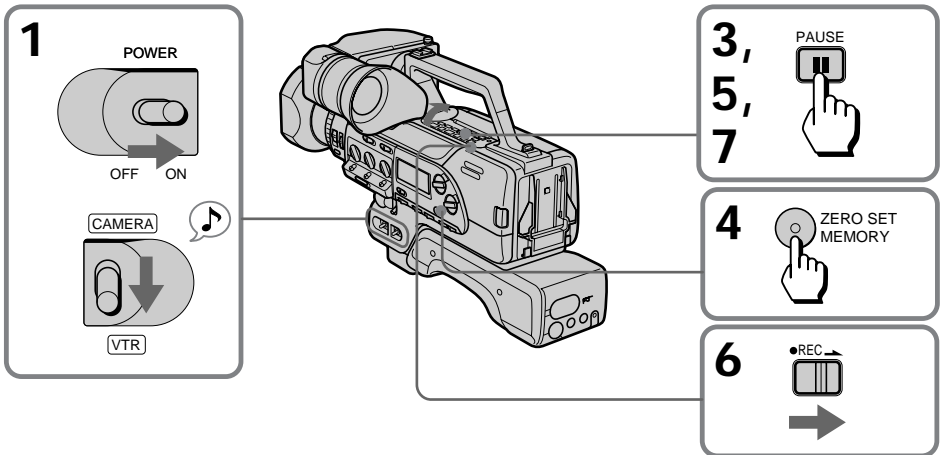

## To change the end point

Press ZERO SET MEMORY so that “ZERO SET MEMORY” disappears.  
Repeat steps 3 to 4.

## To stop editing

Press **□**.

## To edit without setting the end point

Instead of steps 3 and 4, press **□** at the desired end point.

## Notes on editing

- You cannot edit with equipment which is not connected the DV connector.
- The previous recommended scene is erased when editing starts.
- The picture may be distorted at the end of the inserted portion when it is play back.



# Audio dubbing

If you recorded in 12 bit recording mode, you can add stereo narration or music to the recording.

## Making connections

### To use additional audio line in

Connect the LINE OUT jacks of an audio source to the rear AUDIO IN jacks of the digital camcorder using an audio connecting cord (not supplied) and then set AUDIO INPUT SELECT to LINE.

### To use an additional microphone

Use the built-in microphone or connect an external microphone (not supplied) to the MIC (PLUG IN POWER) jack, then set AUDIO INPUT SELECT to MIC.

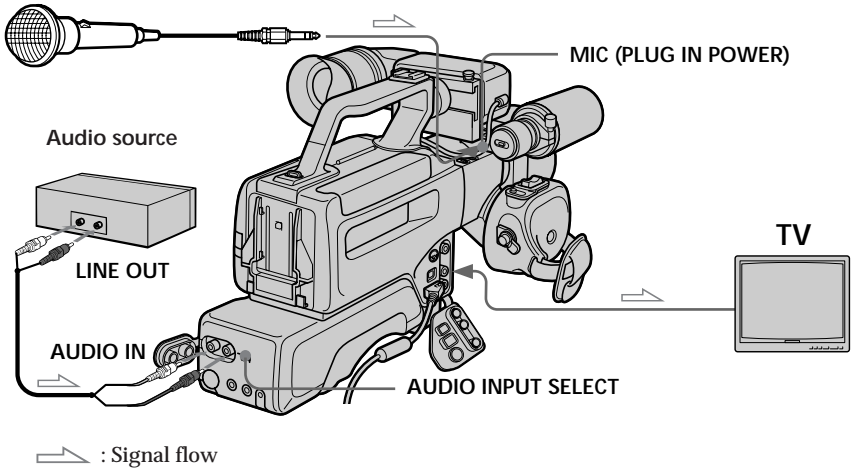

# Audio dubbing

## Recording

- (1) Set the POWER switch to ON and then set CAMERA/VTR to VTR.
- (2) Open the cover, press  $\triangleright$ , then  $\blacktriangleright$  or  $\blacktriangleleft$ , to search for the start and end points of the recording.
- (3) Press  $\parallel$  at the start point of the recording.
- (4) Press AUDIO DUB  $\ominus$ .
- (5) Adjust the recording volume.
- (6) Press  $\parallel$ .

Audio dubbing begins.

If you are using an audio source system, press  $\parallel$  on the stereo at the same time.

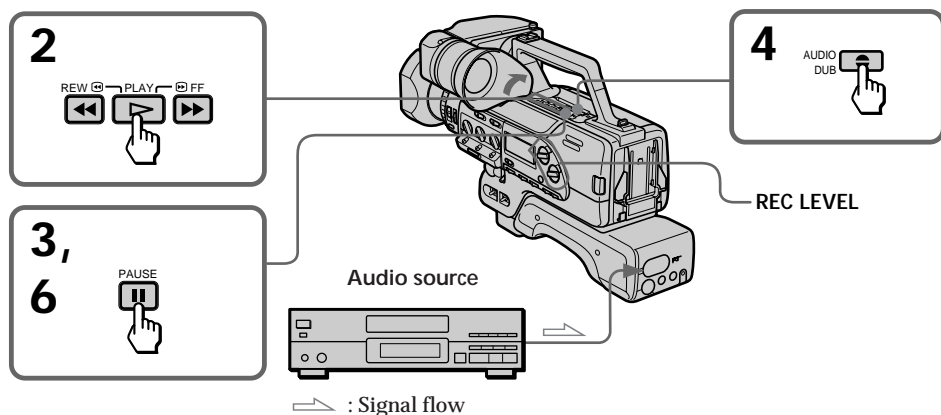

### To stop recording

Press  $\square$ .

### To pause recording

Press  $\parallel$ . To start recording again, press  $\parallel$ .

### To adjust the volume

If you set REC LEVEL to AUTO, the volume is automatically adjusted.

To adjust the volume manually, set REC LEVEL to MANU, and turn the REC LEVEL dials.

### To find the end point of a recording when dubbing

Use the time code display. Set ZERO SET MEMORY to the end point of the recording, and you will be able to see when you have reached the end point.

### Note on audio dubbing

You cannot operate audio dubbing on 16 bit recorded tapes.

# Changing the lithium battery in the digital camcorder

Your digital camcorder is supplied with a lithium battery installed. When the battery becomes weak or dead, the  indicator flashes in the viewfinder for about 5 seconds when you set the digital camcorder to CAMERA mode with the POWER switch ON. In this case, replace the battery with a Sony CR2025 or Duracell DL-2025 lithium battery. Use of any other battery may present a risk of fire or explosion. The lithium battery for the digital camcorder lasts for about 1 year under normal operation. (The lithium battery that comes installed at the factory may not last 1 year.)

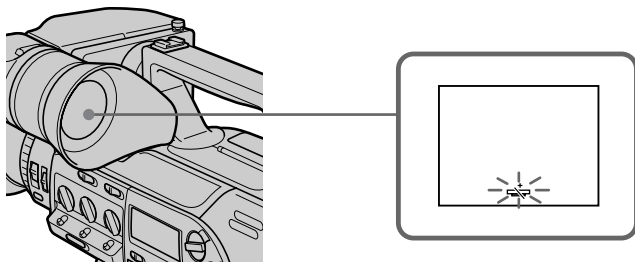

## Notes on lithium battery

- Keep the lithium battery out of the reach of children.  
Should the battery be swallowed, immediately consult a doctor.
- Wipe the battery with a dry cloth to assure a good contact.
- Do not hold the battery with metallic tweezers, otherwise a short-circuit may occur.
- The lithium battery has positive (+) side and negative (-) side as illustrated. Be sure to insert the lithium battery with the positive side facing out.



## WARNING

The battery may explode if mistreated. Do not recharge, disassemble, or dispose of in fire.

## Changing the lithium battery in the digital camcorder

### Changing the lithium battery

When replacing the lithium battery, keep the battery pack or other power source attached. Otherwise, you will need to reset the date, time and other items in the menu system retained by the lithium battery.

- (1) Loosen the two screws under the shoulder pad.
- (2) Slide the shoulder pad toward the back of the camera.
- (3) Open the lid of the lithium battery compartment.
- (4) Push the lithium battery down once and pull it out from the holder.
- (5) Install the lithium battery with the positive (+) side facing out. Close the lid.
- (6) Slide the shoulder pad toward the front of the camera and tighten the screws.

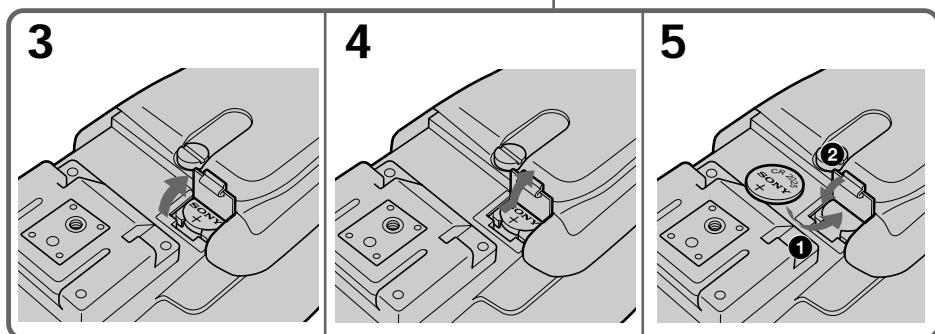
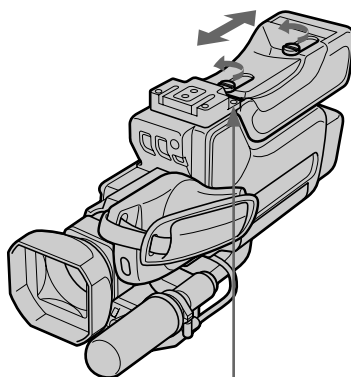

# Resetting the date and time

You can reset the date and time in the menu system.

- (1) Open the cover, then press MENU to display the menu.
- (2) Press  $\checkmark$  to select CLOCK SET, then press EXECUTE.
- (3) Press  $\checkmark$  or  $\wedge$  to select the desired year, then press EXECUTE. Set the day, month, hour, and minutes by pressing  $\checkmark$  /  $\wedge$  and then pressing EXECUTE.
- (4) Press MENU to erase the menu display.

**1** MENU

MENU  
 D ZOOM  $\rightarrow$  OFF  
 16 : 9 WIDE  
 ZEBRA  
 COMMANDER  
 BEEP  
 FRAME REC  
 INT REC  
 [ MENU ] : END

**2**

MENU  
 FRAME REC  
 INT REC  
 SLOW SHTR  
 S PRESET  
 G PRESET  
 CUSTOM  
 CLOCK SET  
 [ MENU ] : END

MENU  
 1996  
 CLOCK SET 12 00 AM  
 [ MENU ] : END

**3**

1997  
 CLOCK SET 12 00 AM  
 [ MENU ] : END

1997 7  
 CLOCK SET 12 00 AM  
 [ MENU ] : END

1997 7 4  
 CLOCK SET 12 00 AM  
 [ MENU ] : END

1997 7 4  
 CLOCK SET 12 00 AM  
 [ MENU ] : END

1997 7 4  
 CLOCK SET 12 00 AM  
 [ MENU ] : END

1997 7 4  
 CLOCK SET 12 00 AM  
 [ MENU ] : END

1997 7 4  
 CLOCK SET 12 00 AM  
 [ MENU ] : END

1997 7 4  
 CLOCK SET 12 00 AM  
 [ MENU ] : END

1997 7 4  
 CLOCK SET 12 00 AM  
 [ MENU ] : END

**4**

1997 7 4  
 CLOCK SET 8 00 AM  
 [ MENU ] : END

1997 7 4  
 CLOCK SET 8 00 AM  
 [ MENU ] : END

**5**

MENU  
 FRAME REC  
 INT REC  
 SLOW SHTR  
 S PRESET  
 G PRESET  
 CUSTOM  
 CLOCK SET  
 [ MENU ] : END

MENU  
 FRAME REC  
 INT REC  
 SLOW SHTR  
 S PRESET  
 G PRESET  
 CUSTOM  
 CLOCK SET  
 1997 7 4  
 8:20:01 AM  
 [ MENU ] : END

## To correct the date and time setting

Repeat the above procedure.

## To check the preset date and time

The date and time are shown in the display window. Which can only be seen when the power is on.

The year changes as follows:

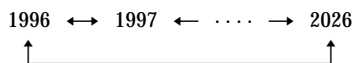

## Note on the time indicator

The internal clock of this digital camcorder operates on a 12-hour cycle.

- 12:00 AM stands for midnight.
- 12:00 PM stands for noon.

# Notes on video cassettes

## Usable cassettes

Use a DV cassette. You cannot use any other **Mini DV** mini DV, **8 mm**, **Hi8** Hi8, **VHS** VHS, **S-VHS** S-VHS, **VHS-C** VHSC, **S-VHS-C** S-VHSC or **B** Betamax cassette.

### We recommend using an ME cassette

You can get the highest quality pictures with this digital camcorder using an ME cassette which is the highest quality cassette.

You may not get as good quality with lesser quality cassettes.

## Copyright signal

### When you play back

Using this digital camcorder, you cannot play back a tape that has recorded copyright control signals for copyright protection of software. "COPY INHIBIT" appears on the TV and in the viewfinder if you try to play back such a tape. This digital camcorder does not record copyright control signals on the tape when it records.

## Notes on the DV cassette

### Gold-plated connector of the DV cassette

If the gold-plated connector of the DV cassette gets dirty or dust sticks to the connector, the digital camcorder may malfunction when using the cassette memory functions such as cassette memory search.

Clean the connector with the swab once every ten times you eject the cassette [a].

### To prevent accidental erasure

Slide the protect tab on the cassette so that the red portion is visible [b].

### When affixing a label on the DV cassette

Be sure to affix a label on only the location illustrated below so as not to cause malfunction of the digital camcorder [c].

### After using the DV cassette

After use, please be sure to rewind the tape completely (to prevent picture and sound distortion).

Return to its case and store in upright position.

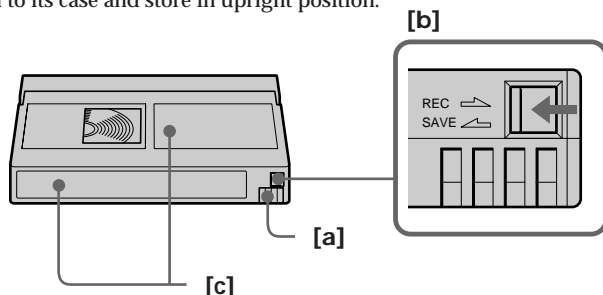

# Tips for using the battery pack

This section shows you how you can get the most out of your battery pack.

## Preparing the battery pack

### Always carry additional batteries

Have sufficient battery pack power to do 2 to 3 times as much recording as you have planned.

### Battery life is shorter in a cold environment

Battery efficiency is decreased, and the battery will be used up more quickly, if you are recording in a cold environment.

### To save battery power

Turn STANDBY down to LOCK when not recording to save battery power.

A smooth transition between scenes can be made even if recording is stopped and started again. While you are positioning the subject, selecting an angle, or looking through the viewfinder lens, the lens moves automatically and the battery is used. The battery is also used when a tape is inserted or removed.

## When to replace the battery pack

While you are using your digital camcorder, the remaining battery indicator in the viewfinder decreases gradually as battery power is used up.



When the remaining battery indicator reaches the lowest point, the  $\infty$  indicator may appear and start flashing in the viewfinder.

When the  $\infty$  indicator in the viewfinder changes from slow flashing to rapid flashing while you are recording, set the POWER switch to OFF on the digital camcorder and replace the battery pack. Leave the tape in the digital camcorder to obtain a smooth transition between scenes after the battery pack has been replaced.

## Notes on the rechargeable battery pack

### Caution

Never leave the battery pack in temperatures above 60°C (140°F), such as in a car parked in the sun or under direct sunlight.

### The battery pack heats up

During charging or recording, the battery pack heats up. This is caused by energy that has been generated and a chemical change that has occurred inside the battery pack. This is not cause for concern and is normal.

### Battery pack care

- Remove the battery pack from the digital camcorder after using it, and keep it in a cool place. When the battery pack is installed to the digital camcorder, a small amount of current flows to the digital camcorder even if the POWER switch is set to OFF. This shortens battery life.
- The battery pack is always discharging even when it is not in use after charging. Therefore, you should charge the battery pack right before using the digital camcorder.

## Tips for using the battery pack

### The switch on the battery pack

This switch is provided so that you can mark the charged battery pack. Set the switch to the “green mark” position when charging is completed. (When removed from the charging adaptor, the switch exposes the green mark. When removed from your digital camcorder, no mark is indicated.)

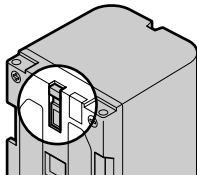

### The life of the battery pack

If the battery indicator flashes rapidly just after turning on the digital camcorder with a fully charged battery pack, the battery pack should be replaced with a new fully charged one.

### Charging temperature

You should charge batteries at temperatures from 10°C to 30°C (from 50°F to 86°F). Lower temperatures require a longer charging time.

## Notes on charging

### A brand-new battery pack

A brand-new battery pack is not charged. Before using the battery pack, charge it completely.

### Recharge the battery pack whenever you like

You do not have to discharge it before recharging. If you charged the battery pack fully but you did not use it for a long time, it becomes discharged. Then recharge the battery pack before use.

## Notes on the terminals

If the terminals (metal parts on the back) are not clean, the battery charge duration will be shortened.

When the terminals are not clean or when the battery pack has not been used for a long time, repeatedly install and remove the battery pack a few times. This improves the contact condition. Also, wipe the + and - terminals with a soft dry cloth or paper.

### Be sure to observe the following

- Keep the battery pack away from fire.
- Keep the battery pack dry.
- Do not open nor try to disassemble the battery pack.
- Do not expose the battery pack to any mechanical shock.





# Maintenance information and precautions

## Moisture condensation

If the digital camcorder is brought directly from a cold place to a warm place, moisture may condense inside the digital camcorder, on the surface of the tape, or on the lens. In this condition, the tape may stick to the head drum and be damaged or the unit may not operate correctly. To prevent possible damage under these circumstances, the digital camcorder is furnished with moisture sensors. Please, take the following precautions.

### Inside the digital camcorder

If there is moisture inside the digital camcorder, the beep sounds and the  indicator flashes. If this happens, none of the functions except cassette ejection will work. Open the cassette compartment, turn off the digital camcorder, and leave it about 1 hour. When  indicator flashes at the same time, the cassette is inserted in the digital camcorder. Eject the cassette, turn off the digital camcorder, and leave also the cassette about 1 hour. You can continue use of digital camcorder when the  indicator does not appear when the power is turned on again.

### On the lens

If moisture condenses on the lens, no indicator appears, but the picture becomes dim. Turn off the power and do not use the digital camcorder for about 1 hour.

### How to prevent moisture condensation

When bringing the digital camcorder from a cold place to a warm place, put the digital camcorder in a plastic bag and allow it to adapt to room conditions over a period of time.

- (1) Be sure to tightly seal the plastic bag containing the digital camcorder.
- (2) Remove the bag when the air temperature inside it has reached the temperature surrounding it (after about 1 hour).

## Video head cleaning

To ensure normal recording and clear pictures, clean the video heads.

The video heads may be dirty when:

- mosaic-pattern noise appears on the playback picture
- playback pictures do not move
- playback pictures are hardly visible
- the playback picture does not appear
- the  indicator flashes in the viewfinder.



If the picture becomes like [a] or [b], clean the video heads with the Sony DV-12CL cleaning cassette (not supplied). After checking the picture, if it is still “noisy”, repeat the cleaning. (Do not repeat cleaning more than 5 times.)

### Note

If the Sony DV-12CL cleaning cassette (not supplied) is not available in your area, consult your nearest Sony dealer.

## Maintenance information and precautions

### Removing dust from inside the viewfinder

- (1) While pressing PUSH, open the viewfinder.
- (2) Clean the surface with a commercially available blower.
- (3) Close the viewfinder until it clicks.

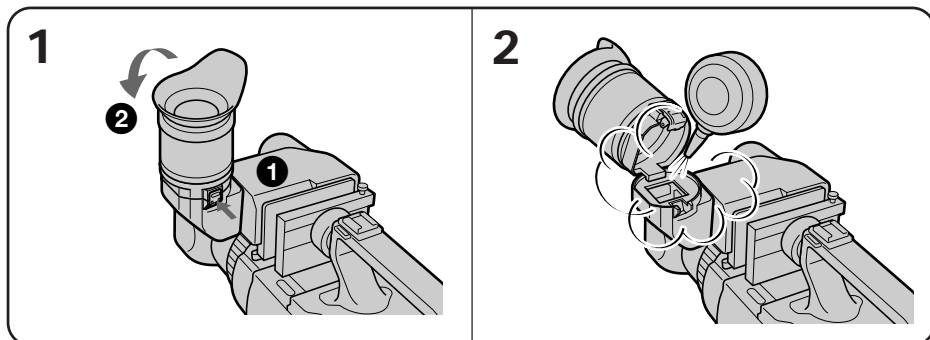

### Precautions

#### Digital camcorder operation

- Operate the digital camcorder on 7.2 V (battery pack) or 8.4 V (AC power adaptor).
- For DC or AC operation, use the accessories recommended in this manual.
- Should any solid object or liquid get inside the casing, unplug the digital camcorder and have it checked by a Sony dealer before operating it any further.
- Avoid rough handling or mechanical shock. Be particularly careful of the lens.
- Keep the POWER switch set to OFF when not using the digital camcorder.
- Do not wrap up the digital camcorder and operate it since heat may build up internally.
- Keep the digital camcorder away from strong magnetic fields or mechanical vibration.

#### On Handling Tapes

- Do not insert anything into the small holes on the cassette.
- Do not open the tape protect cover or touch the tape.
- Avoid touching or damaging the terminals.  
To remove dust, clean the terminals with a soft cloth.

## Digital camcorder care

- When the digital camcorder is not to be used for a long time, disconnect the power source and remove the tape. Periodically turn on the power, operate the camera and player sections and play back a tape for about 3 minutes.
- Clean the lens with a soft brush to remove dust. If there are fingerprints on it, remove them with a soft cloth.
- Clean the digital camcorder body with a dry soft cloth, or a soft cloth lightly moistened with a mild detergent solution. Do not use any type of solvent which may damage the finish.

## AC power adaptor

### Charging

- Use only a lithium ion type battery pack.
- Place the battery pack on a flat surface without vibration during charging.
- The battery pack will get hot during charging. This is normal.

### Others

- Unplug the unit from the wall outlet when not in use for a long time. To disconnect the power cord pull it out by the plug. Never pull the power cord itself.
- Do not operate the unit with a damaged cord or if the unit has been dropped or damaged.
- Do not bend the power cord forcibly, or put a heavy object on it. This will damage the cord and may cause a fire or electrical shock.
- Be sure that nothing metallic comes into contact with the metal parts of the connecting plate. If this happens, a short may occur and the unit may be damaged.
- Always keep the metal contacts clean.
- Do not disassemble the unit.
- Do not apply mechanical shock or drop the unit.
- While the unit is in use, particularly during charging, keep it away from AM receivers and video equipment because it will disturb AM reception and video operation.
- The unit becomes warm while in use. This is normal.
- Do not place the unit in locations that are:
  - Extremely hot or cold
  - Dusty or dirty
  - Very humid
  - Vibrating

If any difficulty should arise, unplug the unit and contact your nearest Sony dealer.



This mark indicates that this product is a genuine accessory for Sony video products.

When purchasing Sony video products, Sony recommends that you purchase accessories with this "GENUINE VIDEO ACCESSORIES" mark.

# Using your digital camcorder abroad

Each country has its own electric and TV color systems. Before using your digital camcorder abroad, check the following points.

## Power sources

You can use your digital camcorder in any country with the AC-V615 AC power adaptor within 100 V to 240 V AC, 50/60 Hz.

## Difference in color systems

This digital camcorder is an NTSC system based digital camcorder. If you want to view the playback picture on a TV, it must be an NTSC system based TV. Check the following list.

### NTSC system countries

Bahama Islands, Bolivia, Canada, Central America, Chile, Colombia, Ecuador, Jamaica, Japan, Korea, Mexico, Peru, Surinam, Taiwan, the Philippines, the U.S.A., Venezuela, etc.

### PAL system countries

Australia, Austria, Belgium, China, Denmark, Finland, Germany, Great Britain, Holland, Hong Kong, Italy, Kuwait, Malaysia, New Zealand, Norway, Portugal, Singapore, Spain, Sweden, Switzerland, Thailand, etc.

### PAL-M system country

Brazil

### PAL-N system countries

Argentina, Paraguay, Uruguay

### SECAM system countries

Bulgaria, Czech Republic, France, Guyana, Hungary, Iran, Iraq, Monaco, Poland, Russia, Slovak Republic, Ukraine, etc.

# Trouble check

If you run into any problem using the digital camcorder, use the following table to troubleshoot the problem. Should the difficulty persist, disconnect the power source and contact your Sony dealer or local authorized Sony service facility.

## Digital camcorder

### Power

Symptom	Cause and/or Corrective Action
The power is not on.	<ul style="list-style-type: none"><li>• The battery pack is not installed. → Install the battery pack. (p. 9)</li><li>• The battery is dead. → Use a charged battery pack. (p. 7)</li><li>• The AC power adaptor is not connected to a wall outlet. → Connect the AC power adaptor to a wall outlet. (p. 24)</li></ul>
The power goes off.	<ul style="list-style-type: none"><li>• While being operated in CAMERA mode, the digital camcorder has been in Standby mode for more than 5 minutes. → Turn STANDBY down once and then up again. (p. 12)</li><li>• The battery is dead. → Use a charged battery pack. (p. 7)</li></ul>
The battery pack is quickly discharged.	<ul style="list-style-type: none"><li>• The ambient temperature is too low. (p. 71)</li><li>• The battery pack has not been charged fully. → Charge the battery pack again. (p.7)</li><li>• The battery pack is completely dead, and cannot be recharged. → Use another battery pack. (p. 72)</li></ul>

### Operation

Symptom	Cause and/or Corrective Action
START/STOP does not operate.	<ul style="list-style-type: none"><li>• The tape is stuck to the drum. → Eject the tape. (p. 11)</li><li>• The tape has run out. → Rewind the tape or use a new one. (p. 22)</li><li>• CAMERA/VTR is set to VTR. → Set it to CAMERA. (p. 12)</li><li>• The tab on the cassette is out (red). → Use a new tape or slide the tab. (p. 11)</li></ul>
The cassette cannot be removed from the holder.	<ul style="list-style-type: none"><li>• The battery is dead. → Use a charged battery pack or the AC power adaptor. (p. 7, 24)</li></ul>
and indicators flash and no function except for cassette ejection works.	<ul style="list-style-type: none"><li>• Moisture condensation has occurred. → Remove the cassette and leave the digital camcorder for at least 1 hour. (p. 73)</li></ul>
The time code is flashing in display window.	<ul style="list-style-type: none"><li>• The lithium battery is weak or dead. → Replace the lithium battery with a new one. (p. 68)</li></ul>

## Trouble check

Symptom	Cause and/or Corrective Action
The tape does not move when a video control button is pressed.	<ul style="list-style-type: none"><li>• CAMERA/VTR is set to CAMERA. → Set it to VTR. (p. 22)</li><li>• The tape has run out. → Rewind the tape or use a new one. (p. 22)</li><li>• The digital camcorder is updating the cassette memory data (only for DV cassettes with cassette memory). → Eject the cassette after the C MEMORY indicator disappears. (p. 11)</li></ul>
The Steady Shot function does not activate.	<ul style="list-style-type: none"><li>• STEADY SHOT is set to OFF. → Set STEADY SHOT to ON. (p. 55)</li></ul>
The autofocus function does not work.	<ul style="list-style-type: none"><li>• FOCUS is set to MANU. → Set it to AUTO. (p. 39)</li><li>• Shooting conditions are not suitable for autofocus. → Set FOCUS to MANU to focus manually. (p.38)</li></ul>
The microphone does not work while recording.	<ul style="list-style-type: none"><li>• AUDIO INPUT SELECT is set to LINE. → Set it to MIC.</li></ul>
Built-in microphone sound does not record in stereo when monitoring by headphone or line out jacks.	<ul style="list-style-type: none"><li>• DIRECTION SELECT is set to 0°. → Set it to 90° or 120°. (p. 14)</li></ul>
Audio dubbing does not work.	<ul style="list-style-type: none"><li>• Audio format of recording tape is 16 bit. → Dub the tape into another DV cassette in 12 bit using AV connecting cable. (p. 15)</li></ul>
Excessive high-pitched sound is heard.	<ul style="list-style-type: none"><li>• The picture has been recorded with BUILT-IN MIC set to WIND. → When there is no wind, set it to off (green position). (p. 53)</li></ul>
The date and time indicator disappears.	<ul style="list-style-type: none"><li>• Reset the date and time. (p. 69)</li></ul>
The overlap function does not work.	<ul style="list-style-type: none"><li>• Set DIGITAL MODE to OVERLAP. (p. 30)</li></ul>
D ZOOM does not work.	<ul style="list-style-type: none"><li>• Set DIGITAL MODE to ZOOM/16:9 WIDE and set D ZOOM in the menu to ON. (p. 27)</li></ul>
D ZOOM or 16:9 WIDE mode in the menu system cannot be set to ON.	<ul style="list-style-type: none"><li>• Set DIGITAL MODE to ZOOM/16:9 WIDE. (p. 27)</li></ul>
The slow shutter does not work.	<ul style="list-style-type: none"><li>• Set DIGITAL MODE to ZOOM/16:9 WIDE.</li></ul>

## Picture

Symptom	Cause and/or Corrective Action
The image on the viewfinder screen is not clear.	<ul style="list-style-type: none"> <li>The viewfinder lens is not adjusted. → Adjust the viewfinder lens. (p. 13)</li> </ul>
A vertical band appears when a subject such as lights or a candle flame is shot against a dark background.	<ul style="list-style-type: none"> <li>When the contrast between the subject and background is too high, vertical band appears, the digital camcorder is not malfunctioning. → Change locations.</li> </ul>
A vertical band appears when shooting a very bright subject.	<ul style="list-style-type: none"> <li>This is a "smear". The digital camcorder is not malfunctioning.</li> </ul>
The picture is "noisy" or hardly visible.	<ul style="list-style-type: none"> <li>The video heads may be dirty. → Clean the heads using the Sony DV-12CL cleaning cassette (not supplied). (p. 73)</li> </ul>
⊗ indicator flashes in the viewfinder.	<ul style="list-style-type: none"> <li>The video heads may be dirty. → Clean the heads using the Sony DV-12CL cleaning cassette (not supplied). (p. 73)</li> </ul>
Battery remaining indicator does not indicate full  when you insert a charged battery pack.	<ul style="list-style-type: none"> <li>The ambient temperature is too low.</li> <li>The battery pack is completely dead, and cannot be recharged. → Use another battery pack. (p. 72)</li> </ul>
While editing using the DV connecting cable, recording picture cannot be monitored.	<ul style="list-style-type: none"> <li>Remove the DV connecting cable, and connect it again.</li> </ul>

## Others

Symptom	Cause and/or Corrective Action
The supplied Remote Commander does not work.	<ul style="list-style-type: none"> <li>COMMANDER is set to OFF in the menu system. → Set it to VTR4 or ID. (p. 27)</li> <li>VTR4/ID/VTR2 on the Remote Commander is set to ID. → Register the ID of the Remote Commander to the digital camcorder. (p. 89)</li> <li>Something is blocking the infrared rays. → Remove the obstacle.</li> <li>The batteries are not inserted with the correct polarity. → Insert the batteries with the correct polarity. (p. 88)</li> <li>The batteries are dead. → Insert new ones. (p. 88)</li> </ul>
There is dust in the viewfinder.	<ul style="list-style-type: none"> <li>While pressing PUSH, open the viewfinder. Clean the viewfinder surface. (p.74)</li> </ul>

(to be continued)

## Trouble check

### AC power adaptor

Symptom	Corrective Actions
The VTR/CAMERA or CHARGE lamp does not light.	• Disconnect the power cord. After about 1 minute, reconnect the power cord.
The CHARGE lamp flashes.	• See the following chart.

#### When the CHARGE lamp flashes

Check through the following chart.

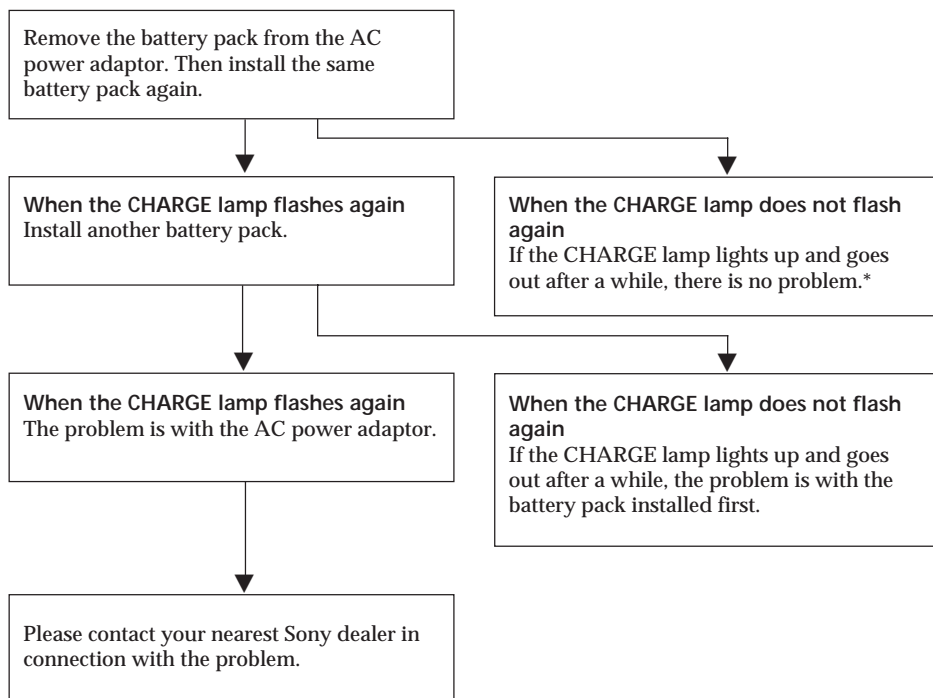

\* If you use a battery pack which you have just bought or which has been left unused for a long time, the CHARGE lamp may flash at the first charging. This does not indicate a problem. Repeat again to charge with the same battery pack.



# Specifications

## System

### Video recording system

Two rotary heads, Helical scanning system

### Audio recording system

Two rotary heads, PCM system

### Video signal

NTSC color, EIA standards

### Usable cassette

DV logo printed cassette

### Recording / Playback time

(using DV-120ME2 cassette)

2 hours

### Fastforward/rewind time

Approx. 3 min.

### Image device

3 CCD (Charge Coupled Device 1/3")

### Viewfinder

Electronic viewfinder:

Monochrome

### Lens

10x (optical), 20x (digital)

f = 5.9 to 59 mm

42 to 420 mm

when converted into a 35-mm still camera

F = 1.6 to 2.1

Filter diameter 52 mm

### Color temperature

Auto/Indoors (3200 K)/

Outdoors (5800 K)/one-push

### Minimum illumination

8 lux (F 1.6)

### Illumination range

8 lux to 100,000 lux

### Recommended illumination

More than 100 lux

### Shutter speed control

1/4 to 1/10,000

### Gain control

-3 to 18 dB

### Aperture control

F 1.6 to F 11, CLOSE

## Input and output connectors

### S video output

4-pin mini DIN

Luminance signal: 1 Vp-p, 75

ohm, unbalanced

Chrominance signal: 0.286 Vp-p, 75ohm, unbalanced

### Video output

Phono jack, 1 Vp-p, 75 ohm, unbalanced

### Audio output

Phono jacks (2: stereo L and R)

327 mV, (at load impedance 47 kilohm) impedance less than

2.2kilohm

### RFU DC OUT

Special minijack, DC 5V

### Headphone jack

Stereo minijack (ø 3.5 mm)

### LANC control jack

Stereo mini-minijack (ø 2.5 mm)

### MIC jack

Stereo minijack, 0.388 mV low impedance with 2.5 to 3.0 V DC, output impedance 6.8 kilohm (ø 3.5 mm)

### Audio input

Phono jacks (2: stereo L and R)

327 mV, impedance more than 4.7 kilohm

### Speaker

Dynamic speaker

### DC input

4-pin connector

### DV IN/OUT

4-pin special connector

### Viewfinder connector

8-pin connector

## General

### Power requirements

7.2 V (battery pack)

8.4 V (AC power adaptor)

### Average power consumption

11.6 W during camera recording

### Operating temperature

0°C to 40°C (32°F to 104°F)

### Storage temperature

-20°C to +60°C (-4°F to +140°F)

### Dimensions (Approx.)

216 x 225 x 470 mm (w/h/d)

(when the viewfinder is lying flat)

### Mass (Approx.)

3.4 kg excluding the battery pack, lithium battery, cassette and lens cover

3.7 kg including the battery pack NP-F950, lithium battery CR2025, cassette DV-120ME2 and lens cover

### Microphone

Stereo type

### Supplied accessories

See page 5.

Design and specifications are

subject to change without notice.

# Identifying the parts

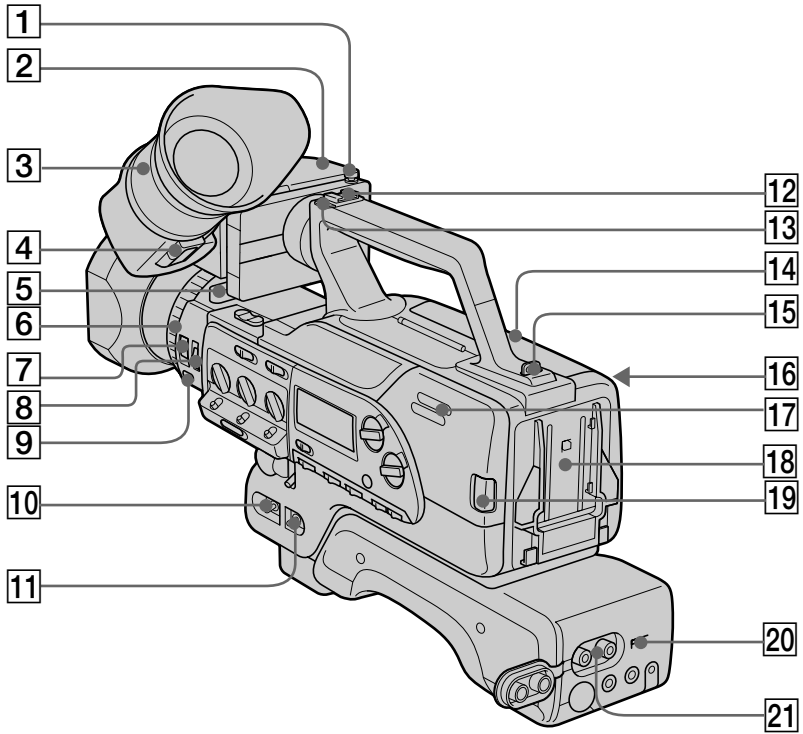

- 1** Stopper (p. 6)
- 2** Viewfinder (p. 6, 13, 74)
- 3** Viewfinder adjustment ring (p. 13)
- 4** PUSH button (p. 74)
- 5** Viewfinder release lever (p. 17)
- 6** Focus ring (p. 39)
- 7** FOCUS switch (p. 39)
- 8** ND FILTER switch (p. 50)
- 9** PUSH AUTO button (p. 39)
- 10** POWER switch (p. 12)
- 11** CAMERA/VTR switch (p. 12, 22)

- 12** Accessory shoe (p. 33)
- 13** Hook for shoulder strap (p. 92)
- 14** Cassette compartment and cassette compartment cover (p. 10)
- 15** Hook for shoulder strap (p. 92)
- 16** EJECT ▲ button (p. 10)
- 17** Speaker (p. 14)
- 18** Battery mounting surface (p. 9)
- 19** BATT lever (p. 9)
- 20** AUDIO INPUT SELECT switch (p. 65)
- 21** AUDIO IN jacks (p. 65)

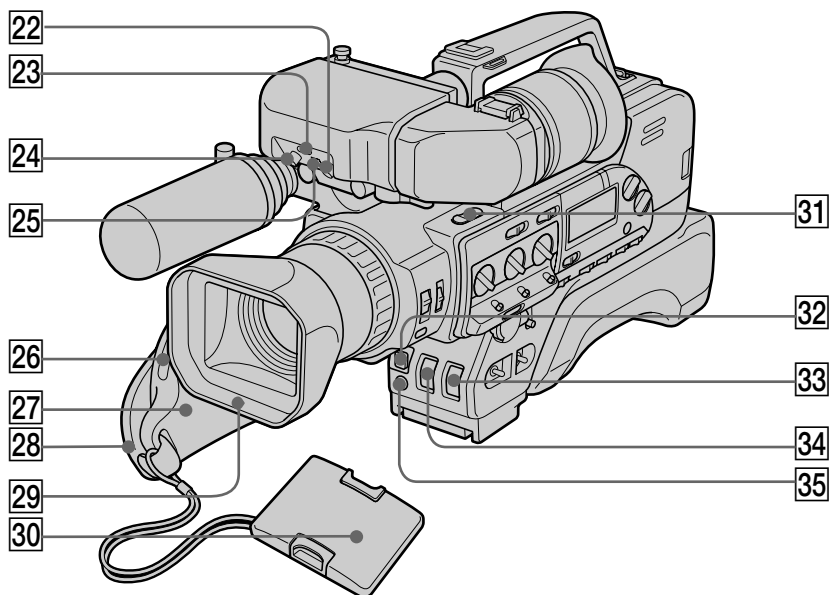

- 22** BRIGHT knob (p. 13)
- 23** TALLY lamp (p. 13)
- 24** CONTR knob (p. 13)
- 25** TALLY switch (p. 13)
- 26** Front Remote Commander sensor (p. 90)
- 27** Grip (p. 16)
- 28** Grip strap (p. 16)
- 29** Lens hood
- 30** Lens hood cap (p. 12)
- 31** EDITSEARCH button (p. 19)
- 32** Front START/STOP button (p. 17)
- 33** FADER/OVERLAP button (p. 29, 30)
- 34** WHITE BALANCE  (one-push white balance) button (p. 48)
- 35** CP CHECK button (p. 57)

You can attach a wide teleconversion lens (not supplied) by removing the lens hood. To remove the lens hood, loosen the lens hood screw **50**, and unscrew the lens hood counterclockwise.

## Identifying the parts

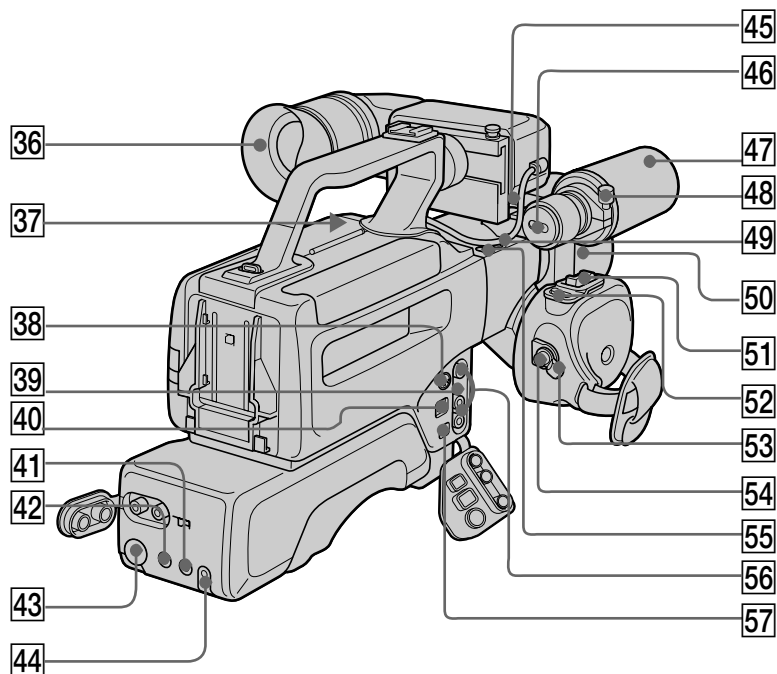

- 36** Eyecup
- 37** VIEW FINDER jack (p. 6)
- 38** S VIDEO OUT jack (p. 20)
- 39** RFU DC OUT jack (p. 21)
- 40** DV IN/OUT jack (p. 62)
- 41** **CL**ANC jack
  - CL** stands for Local Application Control Bus System. The **CL** control jack is used for controlling the tape transport of video equipment and peripherals connected to it. This jack has the same function as the jack indicated as CONTROL L or REMOTE.
- 42**  (headphones) jack (p. 14)
- 43** MONITOR LEVEL dial (p. 14)
- 44** Tally lamp/Rear Remote Commander sensor (p. 13, 90)
- 45** MIC (PLUG IN POWER) jack (p. 14)
  - Connect an external microphone (not supplied). This jack also accepts a “plug-in-power” microphone.
- 46** DIRECTION SELECT switch (p. 14)
- 47** Built-in microphone (p. 53)
- 48** Microphone wind screen screw
  - Loosen the screw to remove wind screen.
- 49** MIC switch (p. 54)
- 50** Lens hood screw
- 51** Power zoom button (p. 15)
- 52** PHOTO button (p. 33)
- 53** STANDBY (LOCK/STANDBY/PHOTO STANDBY) switch (p. 12)
- 54** START/STOP button (p. 12)
- 55** BUILT-IN MIC switch (p. 53)
- 56** AUDIO OUT/VIDEO OUT jacks (p. 20)
- 57** DC IN jack (p. 24)

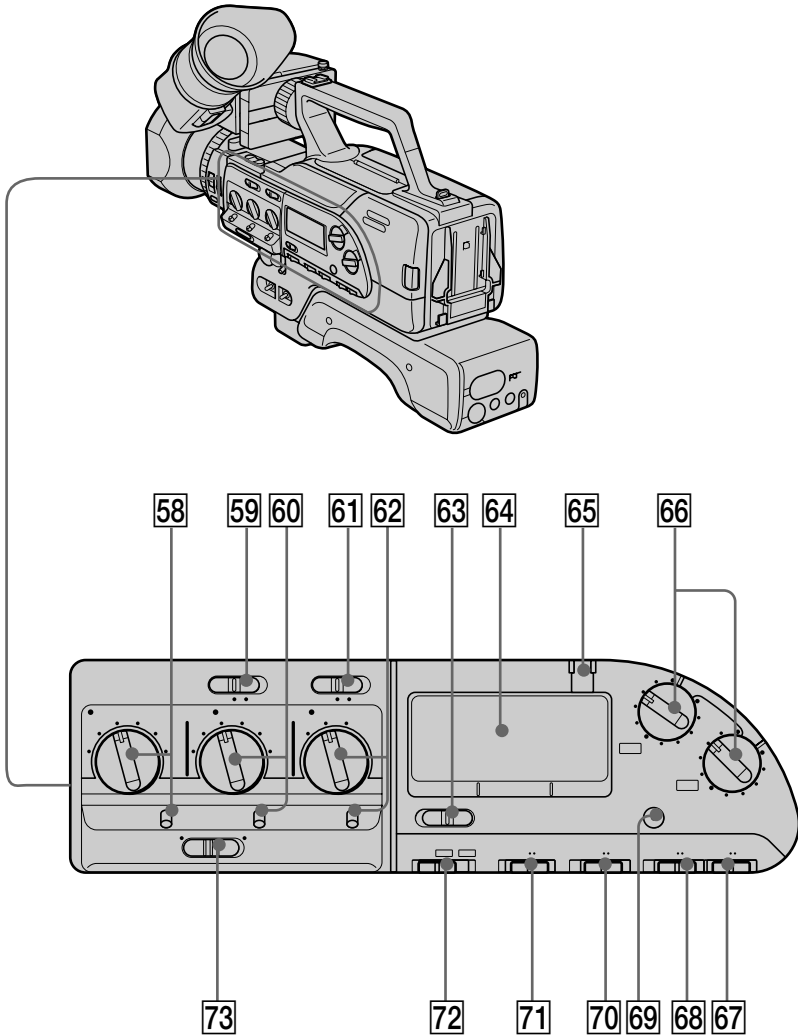

- 58** SHUTTER SPEED dial and AUTO/MANUAL switch (p. 42)
- 59** DIGITAL MODE switch (p. 16, 30, 31, 44)
- 60** GAIN dial and AUTO/MANUAL switch (p. 45)
- 61** STEADY SHOT switch (p. 55)
- 62** WHT BAL (white balance) dial and AUTO/MANUAL switch (p. 48)
- 63** DISPLAY LIGHT switch (for display window)

- 64** Display window (p. 92)
- 65** PEAK indicators (L and R) (p. 52)
- 66** REC LEVEL dials (p. 53)
- 67** REC LEVEL switch (p. 53)
- 68** MIC SELECT switch (p. 54)
- 69** ZERO SET MEMORY button (p. 58)
- 70** AUDIO MODE switch (p. 15)
- 71** SPEAKER switch (p. 14)
- 72** AUDIO MONITOR switch (p. 53)
- 73** AUTO LOCK switch (p. 12, 36)

## Identifying the parts

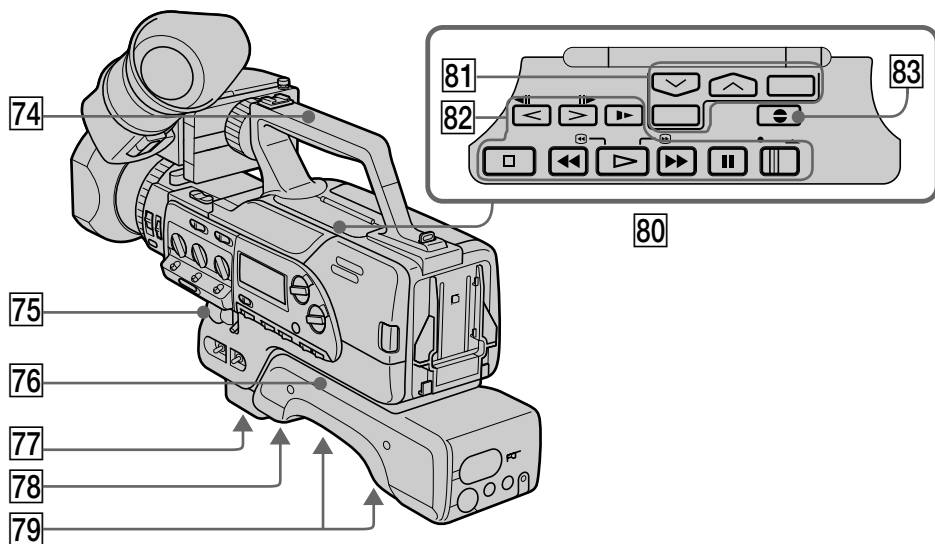

74 Carrying handle

75 IRIS dial and AUTO/MANUAL switch  
(p. 41)

76 Shoulder pad (p. 17)

77 Tripod receptacle (p. 18)

78 Lithium battery cover (p. 68)

79 Shoulder pad screws (p. 17)

80 Cover for menu and video controls

81 Menu buttons (p. 26)

82 Video controls (p. 22)

□ STOP button (stop)

◀◀ REW button (rewind)

▷ PLAY button (playback)

▶▶ FF button (fast forward)

|| PAUSE button (pause)

● REC switch (recording)

▶ SLOW button (slow speed playback)

◀||/||▶ FRAME buttons (direction select/  
frame-by-frame)

83 AUDIO DUB  button (p. 66)

## Attaching the shoulder pad cushion

Attach the supplied shoulder pad cushion to the shoulder pad.

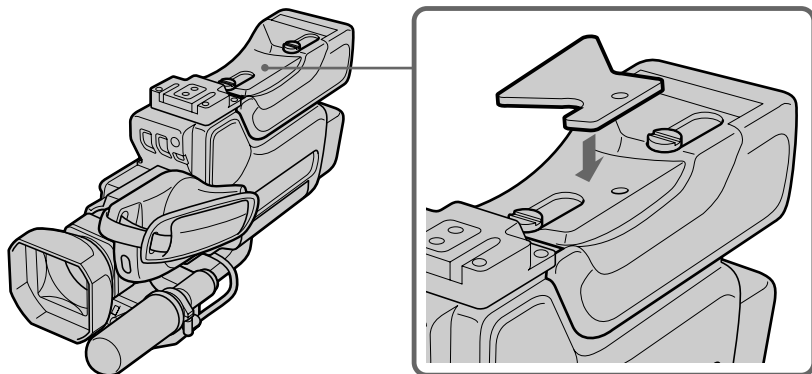

## Attaching the side cushion

We recommend you to attach the side cushion to shoot with stable position.

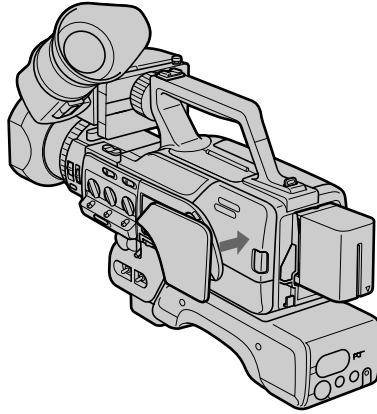

## Remote Commander

The buttons that have the same name on the Remote Commander as on the camcorder function identically.

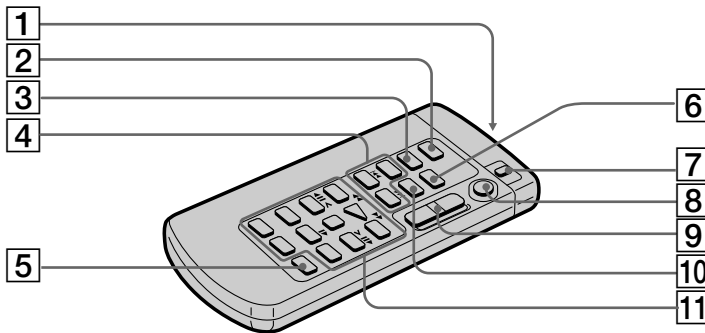

**1** Transmitter

Point toward the remote sensor to control the digital camcorder after turning on the digital camcorder.

**2** PHOTO button (p. 33)

**3** DISPLAY button (p. 22)

**4** SEARCH MODE/◀◀/▶▶ buttons (p. 59)

Press SEARCH MODE to select date search or photo search.

**5** AUDIO DUB button

**6** ZERO SET MEMORY button

**7** VTR4/ID/VTR2 switch (p. 89)

Select VTR4 or ID, the same setting as COMMANDER in the menu system.

The VTR2 position does not function on this digital camcorder.

**8** START/STOP button

**9** Zoom button

The zooming speed is unchangeable by the Remote Commander.

**10** DATA CODE button (p. 61)

**11** Video control buttons

### To prepare the Remote Commander

To use the Remote Commander, you must insert two R6 (size AA) batteries. Use the supplied R6 (size AA) batteries.

- (1) Remove the battery cover from the Remote Commander.
- (2) Insert both of the R6 (size AA) batteries with correct polarity.
- (3) Put the battery cover back onto the Remote Commander.

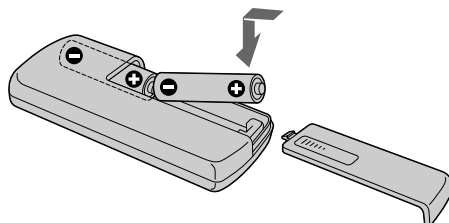

### Note on battery life

The batteries for the Remote Commander last about 6 months under normal operation. When the batteries become weak or dead, the Remote Commander does not work.

### To avoid damage from possible battery leakage

Remove the batteries when you will not use the Remote Commander for a long time.

### To use the Remote Commander

Make sure that the COMMANDER is set to VTR4/ID in the menu system on the digital camcorder.



## About the ID of the Remote Commander

You can avoid having the digital camcorder accidentally respond to signals from other remote commanders by setting the VTR4/ID/VTR2 switch to ID. Use the supplied Remote Commander when you set the switch to ID. When you use the Remote Commander for the first time, register the ID following the procedure below. Once you have registered the ID, you do not need to do so again.

- (1) Open the cover, then press MENU to display the menu in the viewfinder.
- (2) Press  $\vee$  or  $\wedge$  to select COMMANDER, then press EXECUTE.
- (3) Press  $\vee$  or  $\wedge$  to select ID SET.
- (4) Set VTR4/ID/VTR2 on the Remote Commander to ID.
- (5) Point the Remote Commander at the Remote Commander sensor on the digital camcorder and press  $\blacksquare$  STOP on the Remote Commander.

After the beep sound, the ID of the Remote Commander is registered, and the COMMANDER is set to ID in the menu system.

- (6) Press MENU to erase the menu display.

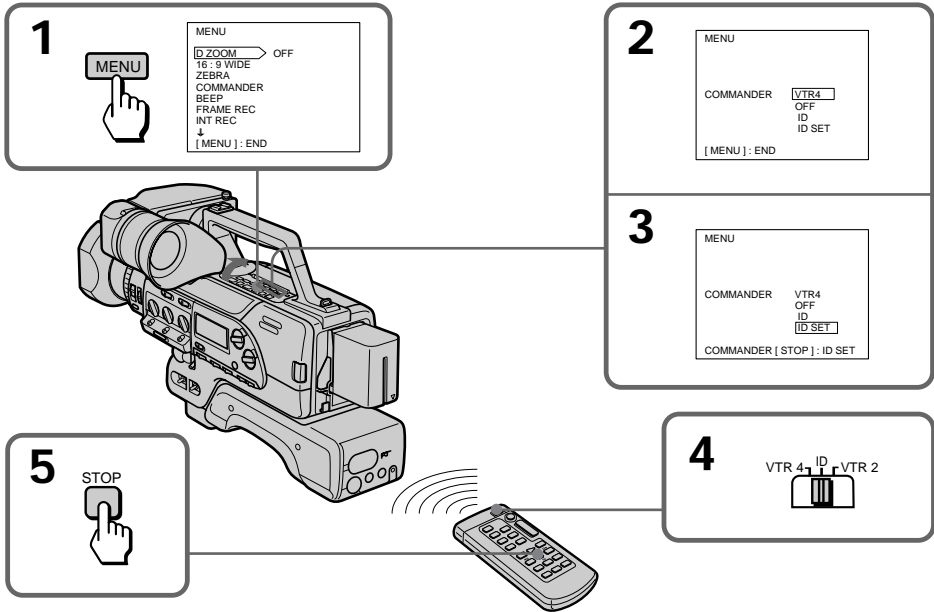

## Identifying the parts

### Remote control direction

Aim the Remote Commander at either of the two remote commander sensors. The range of the Remote Commander is about 5m indoors. Use the Remote Commander as close to flat as possible, otherwise it may not work.

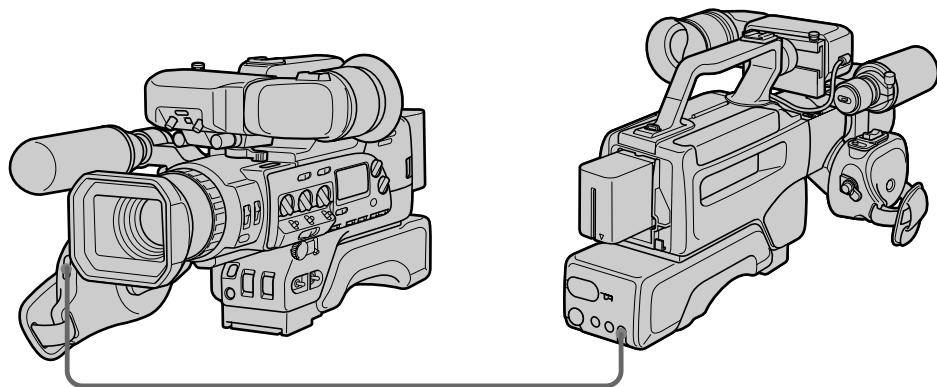

Remote Commander sensors

### Notes on the Remote Commander

- Keep the Remote Commander sensor away from strong light sources such as direct sunlight or illumination. Otherwise, the remote control may not be effective.
- Be sure that there is no obstacle between the Remote Commander sensor on the digital camcorder and the Remote Commander.
- When you operate this digital camcorder using the supplied Remote Commander, other video equipment may work in error. In this case, set the commander modes of this digital camcorder to ID.
- You do not need to store the ID again, after having done so once. Set COMMANDER to ID in the menu system, and set the VTR4/ID/VTR2 switch on the Remote Commander to ID.
- The stored ID is not erased even if you replace the lithium battery.

## In the viewfinder

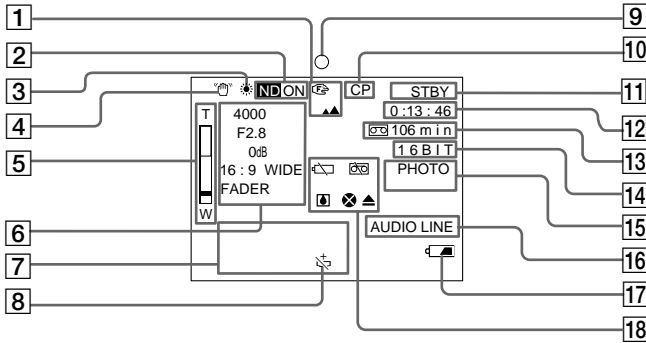

**1** Manual focusing indicator (p. 40)

▲ appears when focusing far, ▼ appears when focusing close.

**2** ND filter indicator (p. 50)

**3** White balance indicator (p. 48)

**4** Steady shot indicator (p. 55)

**5** Zoom indicator (p. 15, 39)

**6** Manual setting data/ wide mode/ fader or overlap indicators (p. 41, 42, 45, 31, 29, 30)

If not set, the indicator disappears, and all indicators below rise 1 row.

**7** Data code indicators (p. 61)

**8** Lithium battery indicator (p. 67)

**9** Recording/battery lamp (p. 12)

**10** Custom preset indicator (p. 56)

**11** Video control mode (p. 12)

**12** Time code

**13** Remaining tape indicator

**14** Audio mode indicator (p. 15)

**15** INTERVAL/ FRAME REC/ PHOTO/ ZERO SET MEMORY/ C MEMORY/ date search/ Photo search indicator (p. 34, 35, 33, 11, 58, 59)

**16** AUDIO LINE/DV IN indicator (p. 65)

When AUDIO INPUT SELECT is set to LINE, this indicator appears

**17** Remaining battery indicator (p. 71)



**18** Warning indicators (p. 93)

## Identifying the parts

### In the display window

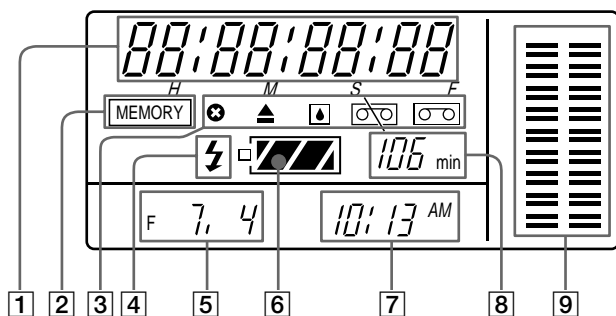

- |   |  |
|---|--|
| <b>1</b> Time code  | <b>5</b> Date/aperture indicator (p. 69, 41) |
| <b>2</b> MEMORY indicator (p. 58)<br>Same as ZERO SET MEMORY indicator in the viewfinder. | <b>6</b> Remaining battery indicator (p. 71) |
| <b>3</b> Warning indicators (p. 93)   | <b>7</b> Time indicator (p. 69)              |
| <b>4</b> Flash indicator  | <b>8</b> Remaining tape indicators           |
|   | <b>9</b> Audio level indicators (p. 52)      |

### Attaching the shoulder strap

Attach the shoulder strap (not supplied) to the hooks for the shoulder strap.

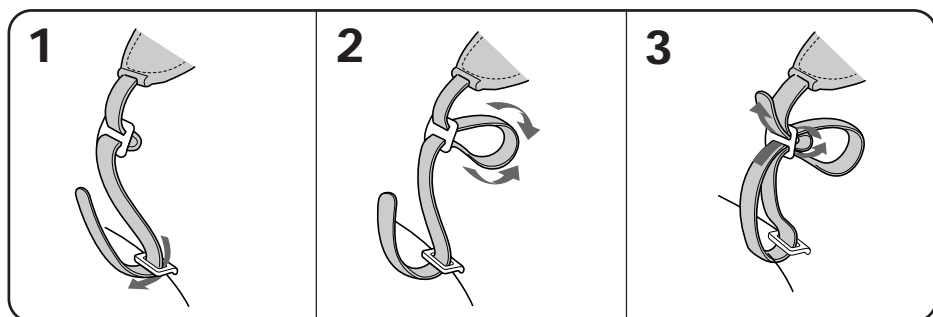

# Warning indicators

If indicators flash in the viewfinder, or a caution lamp on the digital camcorder flashes, check the following:  
 ♪: you can hear the beep sound when the BEEP is set to ON.

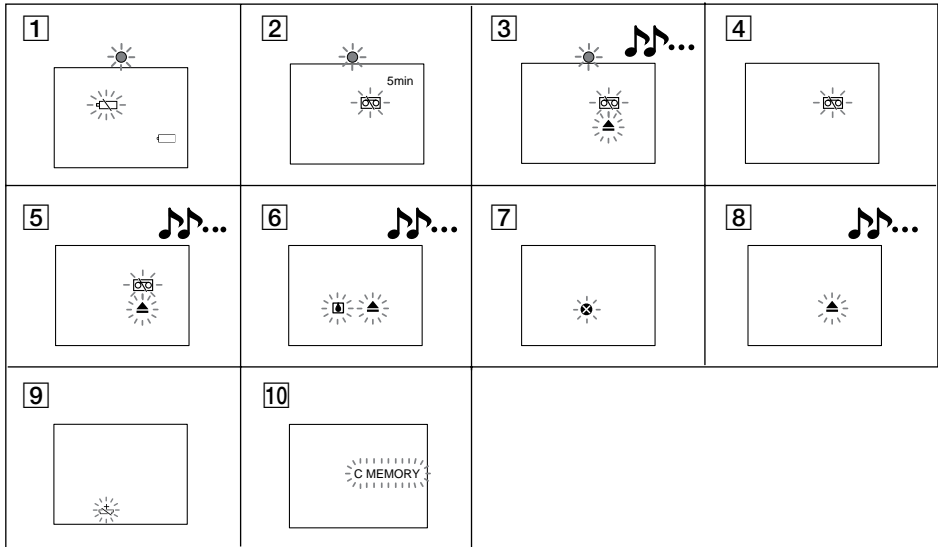

- 1 The battery is weak or dead.  
Slow flashing: The battery is weak.  
Fast flashing: The battery is dead.
- 2 The tape is near the end.  
The flashing is slow.
- 3 The tape has run out.  
The flashing becomes rapid.
- 4 No tape has been inserted.
- 5 The tab on the tape is out (red).
- 6 Moisture condensation has occurred.
- 7 The video heads may be contaminated.  
This indicator appears only in the viewfinder.
- 8 Some other trouble has occurred.  
Disconnect the power source and contact your Sony dealer or local authorized facility.
- 9 The lithium battery is weak or is not installed.
- 10 Updating the cassette memory data.  
Wait until C MEMORY disappears.  
The cassette compartment automatically lifts up and opens after the indicator disappears.

# Index

## A, B

Adjusting viewfinder .....	13
AE SHIFT .....	56
AUDIO MODE .....	15
AUDIO MONITOR .....	53
Auto focus .....	39
AUTO LOCK .....	36
BEEP .....	14
BUILT-IN MIC .....	53

## C, D

Camera recording .....	12
Cassette memory search .....	59
Charging battery .....	7
Cleaning video heads .....	73
Clock set .....	69
Connection .....	20
Custom preset .....	56
DATA CODE .....	61
Depth of field .....	41
DIGITAL MODE .....	16, 30, 31
Digital zoom .....	16
Display window .....	92
DISPLAY .....	22
DV connecting cable .....	62

## E

Editing .....	62
EDITSEARCH .....	19
EJECT (▲) .....	11

## F, G, H

Fade-in/Fade-out .....	29
FADER/OVERLAP .....	29, 30
Gain .....	45
House current .....	24

## I, J, K, L

ID .....	89
LANC .....	84
Lithium battery .....	67

## M, N

Manual focus .....	38
Menu system .....	26
MIC (microphone) jack .....	14
MIC .....	53
ND filter .....	50

## O, P

One-push white balance .....	48
Overlap .....	30
Playback pause .....	23
Power sources .....	24
Power zoom .....	15
PEAK .....	52

## Q, R

Rec review .....	19
Recording mode .....	15
Remote control jack (LANC) ..	84
Reverse .....	23

## S

Shoulder strap .....	92
Shutter speed .....	42
Skip scan .....	23
SPEAKER .....	14
Standby mode .....	14
STEADYSHOT .....	55

## T, U, V

Tripod mounting .....	18
Trouble check .....	77
VTR4 .....	89

## W, X, Y, Z

White balance .....	47
Zebra pattern .....	51
ZERO SET MEMORY .....	58
Zoom .....	15



