

**SONY®**

MULTI ACCESS VIDEO DISK RECORDER

**MAV-555SS** (Ver. 2.32)

***SUPER MOTION***  
VIDEO SYSTEM

***MPEG IMX***

OPERATION MANUAL English

1st Edition (Revised 1)

Serial No. 10001 and Higher

## WARNING

To prevent fire or shock hazard, do not expose the unit to rain or moisture.

To avoid electrical shock, do not open the cabinet. Refer servicing to qualified personnel only.

## AVERTISSEMENT

Afin d'éviter tout risque d'incendie ou d'électrocution, ne pas exposer cet appareil à la pluie ou à l'humidité.

Afin d'écartier tout risque d'électrocution, garder le coffret fermé. Ne confier l'entretien de l'appareil qu'à un personnel qualifié.

## WARNING

Um Feuergefahr und die Gefahr eines elektrischen Schlages zu vermeiden, darf das Gerät weder Regen noch Feuchtigkeit ausgesetzt werden.

Um einen elektrischen Schlag zu vermeiden, darf das Gehäuse nicht geöffnet werden. Überlassen Sie Wartungsarbeiten stets nur qualifiziertem Fachpersonal.



This symbol is intended to alert the user to the presence of important operating and maintenance (servicing) instructions in the literature accompanying the appliance.

**WARNING: THIS WARNING IS APPLICABLE FOR USA ONLY.**

If used in USA, use the UL LISTED power cord specified below. DO NOT USE ANY OTHER POWER CORD.

Plug Cap	Parallel blade with ground pin (NEMA 5-15P Configuration)
Cord	Type SJT, three 16 or 18 AWG wires
Length	Less than 2.5 m (8 ft. 3 in.)
Rating	Minimum 10 A, 125 V

**WARNING:** Using this unit at a voltage other than 120 V may require the use of a different line cord or attachment plug, or both. To reduce the risk of fire or electric shock, refer servicing to qualified service personnel.

**WARNING: THIS WARNING IS APPLICABLE FOR OTHER COUNTRIES.**

1. Use the approved power cord (3-core mains lead)/appliance connector/plug with earthing-contacts that conforms to the safety regulations of each country if applicable.
2. Use the power cord (3-core mains lead)/appliance connector/plug conforming to the proper ratings (voltage, ampere).

If you have questions on the use of the above power cord/appliance connector/plug, please consult a qualified service personnel.

**AVERTISSEMENT: CET AVERTISSEMENT EST APPLICABLE AUX AUTRES PAYS.**

1. Utiliser un cordon d'alimentation approuvé (conducteur d'alimentation 3 âmes)/connecteur d'appareil/prise avec contacts de mise à la terre conforme aux règles de sécurité de chaque pays si applicable.
2. Utiliser un cordon d'alimentation approuvé (conducteur d'alimentation 3 âmes)/connecteur d'appareil/prise conforme aux valeurs nominales (tension, ampérage) correctes.

S'adresser à un personnel de service qualifié pour toute question concernant l'emploi du cordon d'alimentation/connecteur d'appareil/prise ci-dessus.

**WARNING: DIESE WARNUNG GILT FÜR ANDERE LÄNDER.**

1. Verwenden Sie Netzkabel (dreiadrig), Geräteanschlüsse und Netzkabelstecker mit Masseleitung, die den Sicherheitsrichtlinien des jeweiligen Landes entspricht.
2. Verwenden Sie Netzkabel (dreiadrig), Geräteanschlüsse und Netzkabelstecker mit Masseleitung, die den vor Ort herrschenden Spannungsanforderungen (Spannung, Stromstärke) entsprechen.

Bei Fragen über die Eignung und Sicherheit von Netzkabeln (dreiadrig), Geräteanschlüssen und Netzkabelsteckern wenden Sie sich bitte an einen qualifizierten Elektrotechniker.

## WARNING

THIS APPARATUS MUST BE EARTHED.

## AVERTISSEMENT

CET APPAREIL DOIT ÊTRE RELIÉ À LA TERRE.

## WARNING

DIESES GERÄT MUSS GEERDET WERDEN.

## For the customers in the USA

This equipment has been tested and found to comply with the limits for a Class A digital device, pursuant to Part 15 of the FCC Rules. These limits are designed to provide reasonable protection against harmful interference when the equipment is operated in a commercial environment. This equipment generates, uses, and can radiate radio frequency energy and, if not installed and used in accordance with the instruction manual, may cause harmful interference to radio communications. Operation of this equipment in a residential area is likely to cause harmful interference in which case the user will be required to correct the interference at his own expense.

You are cautioned that any changes or modifications not expressly approved in this manual could void your authority to operate this equipment.

The shielded interface cable recommended in this manual must be used with this equipment in order to comply with the limits for a digital device pursuant to Subpart B of Part 15 of FCC Rules.

## For the customers in Europe

This product with the CE marking complies with both the EMC Directive (89/336/EEC) and the Low Voltage Directive (73/23/EEC) issued by the Commission of the European Community. Compliance with these directives implies conformity to the following European standards:

- EN60950: Product Safety
- EN55103-1: Electromagnetic Interference (Emission)
- EN55103-2: Electromagnetic Susceptibility (Immunity)

This product is intended for use in the following Electromagnetic Environment(s):

E1 (residential), E2 (commercial and light industrial), E3 (urban outdoors) and E4 (controlled EMC environment, ex. TV studio).

## Pour les clients européens

Ce produit portant la marque CE est conforme à la fois à la Directive sur la compatibilité électromagnétique (EMC) (89/336/CEE) et à la Directive sur les basses tensions (73/23/CEE) émises par la Commission de la Communauté européenne. La conformité à ces directives implique la conformité aux normes européennes suivantes:

- EN60950: Sécurité des produits
- EN55103-1: Interférences électromagnétiques (émission)
- EN55103-2: Sensibilité électromagnétique (immunité)

Ce produit est prévu pour être utilisé dans les environnements électromagnétiques suivants:

E1 (résidentiel), E2 (commercial et industrie légère), E3 (urbain extérieur) et E4 (environnement EMC contrôlé, ex. studio de télévision).

## Für Kunden in Europa

Dieses Produkt besitzt die CE-Kennzeichnung und erfüllt sowohl die EMV-Direktive (89/336/EEC) als auch die Direktive Niederspannung (73/23/EEC) der EG-Kommission. Die Erfüllung dieser Direktiven bedeutet Konformität für die folgenden Europäischen Normen:

- EN60950: Produktsicherheit
- EN55103-1: Elektromagnetische Interferenz (Emission)
- EN55103-2: Elektromagnetische Empfindlichkeit (Immunität)

Dieses Produkt ist für den Einsatz unter folgenden elektromagnetischen Bedingungen ausgelegt:

E1 (Wohnbereich), E2 (kommerzieller und in beschränktem Maße industrieller Bereich), E3 (Stadtbereich im Freien) und E4 (kontrollierter EMV-Bereich, z.B. Fernsehstudio).

## Voor de Klanten in Nederland

Dit apparaat bevat een vast ingebouwde batterij die niet vervangen hoeft te worden tijdens de levensduur van het apparaat.

Raadpleeg uw leverancier indien de batterij toch vervangen moet worden. De batterij mag alleen vervangen worden door vakbekwaam servicepersoneel.

Gooi de batterij niet weg maar lever deze in als klein chemisch afval (KCA).

Lever het apparaat aan het einde van de levensduur in voor recycling, de batterij zal dan op correcte wijze verwerkt worden.

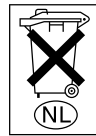

## Für Kunden in Deutschland

Die in diesem Produkt verwendete Speicherbatterie muß während der Lebensdauer des Produkts nicht ausgetauscht werden.

Wenn die Batterie nach langer oder intensiver Nutzung erschöpft ist und entsorgt werden muß, wenden Sie sich bitte an den Händler, bei dem Sie das Produkt erworben haben. Um einen möglichen Kurzschluß oder elektrischen Schlag zu vermeiden, darf die Batterie nur durch qualifiziertes Kundendienstpersonal herausgenommen und ausgetauscht werden.

Entsorgen Sie die Batterie als Sondermüll. Entsorgen Sie sie nicht im normalen Müll.

---

# Table of Contents

---

## Chapter 1 Overview

1-1 MAV-555SS Overview.....	1-1
1-2 Features.....	1-1
1-3 Changes from Ver. 1.00.....	1-4
1-3-1 Changes from Ver. 1.00 to Ver. 2.32.....	1-4
1-4 Optional Accessories.....	1-4

---

## Chapter 2

### Names and Functions of Parts

2-1 Front Panel .....	2-1
2-1-1 Meter Panel.....	2-2
2-1-2 Blank Panel.....	2-6
2-2 System Setup Panel.....	2-6
2-3 Connector Panel .....	2-8
2-4 Analog Audio Expansion Box BKMA-570...	2-11

---

## Chapter 3 Preparations

3-1 MAV-555SS Modes.....	3-1
3-2 Connecting External Devices .....	3-10
3-2-1 Connections with the Panel Mode.....	3-10
3-2-2 Connections with the DTR + Panel Mode .....	3-13
3-2-3 Connections with the DTR + DTR Mode.....	3-15
3-2-4 BVE Mode Connections.....	3-16
3-3 External Synchronization of Output Video Signals .....	3-17
3-4 Setup.....	3-18
3-4-1 Basic Menu Settings .....	3-18
3-4-2 Basic Menu Operation.....	3-23
3-4-3 Contents of the Expansion Menu .....	3-26
3-4-4 Expansion Menu Operation.....	3-41
3-4-5 System Time Settings .....	3-41
3-5 Superimposed Character Information.....	3-42

---

## Chapter 4 Recording & Playback

4-1 Preparations for Recording.....	4-1
4-1-1 Switch Settings .....	4-1
4-1-2 Selecting the Recording Port to be Controlled .....	4-2
4-1-3 Selecting the Video Signals .....	4-2
4-1-4 Selecting the Audio Signals .....	4-2
4-1-5 Selecting the Video and Audio Signals to be Monitored.....	4-2
4-1-6 Adjusting Recording Levels .....	4-3

4-1-7 Selecting the External Device Used for Controlling Recording Operations .....	4-3
4-1-8 Recording Analog Audio .....	4-3
4-2 Preparations for Playback .....	4-4
4-2-1 Switch Settings .....	4-4
4-2-2 Selecting the Playback Port to be Controlled.....	4-5
4-2-3 Selecting the Video and Audio Signals to be Monitored.....	4-5
4-2-4 Selecting the Displayed Time Data.....	4-5
4-2-5 Adjusting Playback Audio Levels.....	4-6
4-2-6 Selecting the External Device Used for Controlling Playback Operations .....	4-6
4-2-7 Remotely Controlling the Video Processor	4-6

---

## Chapter 5 Basic Functions of Each Mode

5-1 Motion Modes .....	5-1
5-1-1 Changing the Motion Mode .....	5-1
5-1-2 Basic Operation with SS Mode.....	5-1
5-2 Changing the Operation Mode.....	5-2
5-3 Basic Operation with Panel Mode .....	5-2
5-3-1 Recording Operation.....	5-2
5-3-2 Playback Operation .....	5-2
5-3-3 EE Signal Selection .....	5-3
5-4 Basic Operations with DTR+Panel and DTR+DTR Modes .....	5-3
5-4-1 Initial Setup for DTR+Panel and DTR+DTR Modes.....	5-3
5-4-2 Basic Operations in DTR+Panel and DTR+DTR Modes.....	5-4
5-5 Basic Operations in BVE Mode .....	5-5
5-5-1 Port Configuration .....	5-5
5-5-2 Basic Operation of the RP Port.....	5-5
5-5-3 Basic Operation of the R2 Port .....	5-7
5-5-4 Basic Operation of the P2 and P3 Ports .....	5-7
5-5-5 New File Names.....	5-8
5-5-6 Monitoring the RP Port.....	5-8
5-5-7 Pre-roll Time .....	5-9
5-5-8 File Backup Function.....	5-9
5-5-9 Editing-Related Error Messages .....	5-9

---

## Appendixes

Error Messages .....	A-1
Specifications.....	A-4

---

# About This Operation Manual

This section describes the organization and use of this manual in using the Sony MAV-555SS Multi Access Video Disk Recorder. This unit is a hard disk recorder, but has the operability of a VTR, allowing easy understanding and operation by those experienced at using VTRs. Read this section to understand how the manual is put together, and determine which sections you need to read, according to your degree of experience with a VTR.

---

## Purpose and intended audience for this manual

This operation manual describes the parts and functions of the MAV-555SS, preparations for operation, basic operations, and other essential information required for using the unit.

This unit is intended for use principally by operators in broadcasting stations and production houses. It therefore assumes that the reader has a general understanding of the operation of VTRs and other broadcast equipment.

Readers well-acquainted with the operation of VTRs and hard disk recorders, after reading Chapter 2 “Names and Functions of Parts”, should be able to understand the operation of the unit, with reference to other sections as required.

However, regardless of experience level, you are recommended to read Chapter 1 “Overview” to get a grasp of the many features and functions of the unit. For first-time users of a VTR or hard disk recorder, or those with limited experience, a thorough reading of this manual is recommended.

---

## Organization of this manual

This manual is divided into chapters as follows. The title page to each chapter also includes a summary of the chapter contents.

### Chapter 1 Overview

This gives an overview of the features of the unit.

### Chapter 2 Names and Functions of Parts

This lists the parts of the unit by function, with summaries of their operation.

### Chapter 3 Preparations

This gives an overview of the various modes of the MAV-555SS (two motion modes and four operation modes), and describes how external devices are connected according to the selected mode.

### Chapter 4 Recording & Playback

This chapter describes the preparations and settings for recording and playback.

### Chapter 5 Basic Functions of Each Mode

Describes basic operation of the various modes of the MAV-555SS described in Chapter 3.

### Appendixes

#### • Error Messages

This appendix lists MAV-555SS errors and warnings that appear on the front display panel.

#### • Specifications

This provides the basic physical specifications, and specifications of the audio and video systems of the unit.

# Using this manual

## Descriptions of operating procedures

The numerals attached to buttons and switches in the illustrations refer to corresponding step numbers in the operating procedure. Additionally, affected switches and indicators which should be checked are indicated.

The first time a technical term appears it is defined in a footnote. Where required, a cross-reference (in italics) shows the page in this manual or in another manual where related information may be found.

Numbers on switches etc. refer to steps in procedure

Step number in procedure

Results of a step and related information

Description of step operation

Cross-reference

### 3-4-2 Basic Menu Operation

To change the factory default settings, proceed as follows.

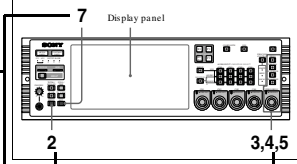

**1** Set the SET UP SELECT switch on the system setup panel to the desired menu bank.

**Note**  
When the menu bank is modified after power up, the MAV-555SS must be restarted or the FAST REBOOT (menu 027) on the Basic menu must be executed. (Changes in settings made while the power is off do not become effective the next time the power is turned on. It is necessary to start up the system a second time.)

**2** Press the MENU button.  
A menu item appears in the time counter display in the display panel.

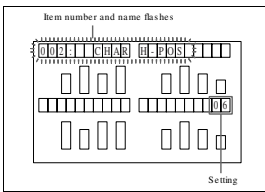

**3** Turn the MENU control to select the item you want to change.  
Turning the MENU control clockwise increases the item number, and turning it counterclockwise decreases the item number.

**4** Press the MENU control once.  
This allows the setting to be changed, and the setting value flashes.

**5** When the desired setting appears, press the MENU control once more.  
This confirms the setting, and the menu item number and name starts flashing again.  
*To change settings in a menu item including a submenu, see the section, "Menu items with submenus".*

**6** To make other menu settings, repeat steps 3 to 5.

**7** When the settings are complete, press the SET button.  
This saves the settings, and the display returns to showing a time value.

**To cancel setting changes**  
In step 7 above, before pressing the SET button, press the MENU button.  
This exits the menu mode, without saving the settings.

**To change the menu display group by group**  
To change the menu display group by group, press the CHROMA button (it is not necessary to hold down the button).  
In this state, turning the MENU control moves from one menu group to the next. To return to the MAIN MENU display, press the CHROMA button once more, or click the MENU control.

**Modes of operating the MENU control**  
It is possible to select either of two modes in which the MENU control operates when selecting items or changing settings: either the value changes only when you turn the control, or the value continues changing even when you stop turning.  
Normally, the state is such that when you use the MENU control to select items or change settings, the value changes only when you turn the MENU control (the value stops changing when you stop turning).  
However, if you press the SETUP/BLACK button, turning on the PRESET indicator above and to the left of the MENU control, the menu item or setting continues changing even when you stop turning.  
To stop the change when the PRESET indicator is lit, do any of the following:

3-4 Setup 3-23 (E)

**4-1-7 Selecting the External Device Used for Controlling Recording Operations**

Use the following procedure to determine whether you should use the optional control panel (BKMA-505) or an external unit when recording with the MAV-555SS.

- With the PORT SELECT buttons, select the recording port to which the setting applies.
- Press the REMOTE button, turning it on or off.

4-1 Preparations for Recording 4-3 (E)

### Example of procedure description

---

## Related manuals

The following related manuals are also available.

- **Installation Manual (supplied)**

This describes the installation procedure for this unit.

- **Maintenance Manual (Option)**

This lists basic maintenance procedures, associated accessories, electrical adjustment procedures, and how to replace the unit's HDDs.





# Chapter 1 Overview

## 1-1 MAV-555SS Overview

The MAV-555SS is a multi-access video disk recorder that supports Super Motion Camera recording of video conforming to the MPEG-2 4:2:2 Profile@Main Level compression format, yielding an excellent image quality. The MAV-555SS is also capable of simultaneous recording of Super Motion images and playback in Sony Super Motion mode (henceforth, SS mode) or Standard Motion mode (henceforth, SD mode). These two motion modes can be selected from the setup menu. High compatibility with VTR-based editing systems is preserved by a VTR-like interface, with the added benefits of high-speed search functions and nonlinear editing made possible by hard disk recording.

In SS mode, the internal hard disk drive (henceforth, HDD) provides a maximum recording time of 6 hours and 20 minutes (30 Mbps/16-bit audio). Recording bit rates of 30, 40, or 50 Mbps can be selected. Input/output can be

configured as 1 input/1 output. The signal type is SDI (4:2:2) for video input/output. AES/EBU is available for audio input/output.

In SD mode, the HDD provides a maximum recording time of 19 hours and 20 minutes (30 Mbps/16-bit audio). Recording bit rates of 30, 40, or 50 Mbps can be selected. Input/output can be configured as 2 input/2 output, 1 input/3 output, or 3 input/1 input. The signal type is SDI (4:2:2) for video input/output. SDI (4:2:2) and AES/EBU are available for audio input/output.

Regardless of the motion mode, installing optional boards (BKMA-513, BKMA-570) allows the use of analog input and output.

An optional dedicated control panel (BKMA-505) is available for real-time control of recording and playback, nonlinear editing, and more.

*For details about the SD and SS modes, see Section 3-1, "MAV-555SS Modes" (page 3-1).*

## 1-2 Features

### ■ SS mode only

#### Super Motion video and audio synchronized playback

In SS mode in the 1 input/1 output configuration, you can record video with an image quality 3 times sharper than normal and perform synchronized playback of video and audio.

#### Easy changing between the SS and SD modes

When the MAV-555SS is not in SS mode, it is possible to change to SD mode from the setup menu and perform normal operations in 2 input/2 output, 1 input/3 output, and 3 input/1 output configurations.

#### Material sharing between modes

In SD mode, you can play back (at 1/3 speed) and edit material recorded in SS mode.

#### Compatible with two different Super Slow cameras

The MAV-555SS simultaneously supports three SDI inputs from the BVP-9500WS System (Sony Super Motion Camera System) and provides one SDI Super Motion output. It can do the same for the Philips LDK23 Camera System. Switch between these two formats from the setup menu.

## Flexible I/O Configuration Possible

Various I/O and control panel options are set according to the external equipment that is connected and the operating environment. The standard input and output configurations of the unit and when various optional boards are installed are shown below.

I/O signals	Configuration for standard equipment and when using optional boards
SDI video	Standard
AES/EBU digital audio	Standard
Composite analog video	<ul style="list-style-type: none"> <li>BKMA-513 (AD/DA converter board) is needed</li> <li>1 output only</li> </ul>
Analog audio (four channels)	<ul style="list-style-type: none"> <li>BKMA-570 (analog audio expansion unit) is needed</li> <li>BKMA-513 (AD/DA converter board) is needed</li> </ul>
Time codes	<ul style="list-style-type: none"> <li>Standard</li> </ul>

For details on the basic options, refer to Section 1-4, "Optional Accessories" (page 1-4).

## Common to SS and SD modes

### Compliance with MPEG-2 4:2:2 Profile @ Main Level

This unit records video with intraframe compression conforming to the MPEG-2 4:2:2 Profile @ Main Level standard. The recording bit rate can be set to 50, 40 or 30 Mbps to suit the intended video application. Maximum recording time depends on bit rate setting and selected Motion mode, as shown in the following table.

Input/output signal	30 Mbps		40 Mbps	50 Mbps
	16-bit	20-bit	20-bit	20-bit
SS mode	6 h 20 min	5 h 20 min	4 h 50 min	3 h 40 min
SD mode	19 h 20 min	16 h	14 h 40 min	11 h 20 min

For details about the SD and SS modes, see Section 3-1, "MAV-555SS Modes" (page 3-1).

### High grade AES/EBU digital audio as standard equipment

This unit provides four independent 20-bit/16-bit AES/EBU digital audio signals on each DSI input/output port. Further, you can record video signals and asynchronous AES/EBU digital audio signals.

### Rapid response to scene searches

The design of this unit puts the emphasis on operability as a disk recorder. In particular, the unit provides VTR-like

operability and response for scene searches, while a unique shuttle system reduces frame drop-out. Variable speed playback is supported by the dedicated control panel (using the optional BKMA-505 control panel) and existing external controllers provide jog, variable, and shuttle control with operability and response comparable to that of a VTR. Digital jog sound is supported, allowing audio segments to be found quickly and easily.

Scene searches and other editing operations on frame-based material files can be carried out rapidly and accurately.

To enhance its function as a disk recorder, high speed cue-up for editing points is also possible.

### Real-time playback process control

Process control of audio and video inputs and outputs can be carried out in real time, using the level adjustment knob on the front panel of the unit.

### Menu-driven setup

The operating conditions, initial settings for interfaces to other devices, and other settings can be controlled by menu operations on the front panel of the unit.

### Nonlinear editing functions through the control panel

The optional control panel (BKMA-505) can be used to perform nonlinear editing through a user interface similar to that used for conventional VTR editing. Furthermore, independent audio channel editing is possible for up to 4 channels.

#### Note

Version 2.30 or later is required for the control panel (BKMA-505).

### Broad range of information displays

The large display panel displays information on the operation of each of the ports (maximum four) in this unit. The displays include timecode values, error messages, setup menu information, HDDs space used and remaining capacity, and audio levels for each port.

### Plug-in printed circuit boards/HDDs

Plug-in components allow easy replacement of printed boards and HDDs, keeping maintenance simple.

### Self-diagnosis functions

If a fault occurs in the system or in a HDD, the cause is diagnosed, and an error code appears on the display panel.

## Security

This unit provides the following functions expected of equipment in broadcasting stations.

### Data protection

In case of HDD failure, RAID technology is used to ensure that data recovery is possible. For example, even if a drive fails during recording, an equivalent drive interpolates the data, allowing operation to continue.

### Help function and information displays

If there are any problems in system operation, error messages appear on the front panel.

## Vibration resistance

The robust construction is resistant against vibration and dust, allowing the unit to be used in vehicle-borne situations. In particular, to protect the HDDs, they are mounted in special caddies independent of the main chassis of the unit.

## Rack mounting

The unit can be mounted in an EIA standard 19-inch rack (optional rack mount kit RMM-555 required).

*For details of rack mounting, refer to the Installation Manual.*

## ■ SD mode only

### Multi-access, Multi-operation (Simultaneous recording/playback operations possible while recording)

One of the advantages of a hard disk recorder (such as the MAV-555SS) over a conventional VTR is the ability to simultaneously access, edit, and output material (stored as files) that is being recorded. The MAV-555SS has four input and output ports standard. Each port can record or playback one video channel and four audio channels. 2 input/2 output, 3 input/1 output, and 1 input/3 output input/output port configurations can be selected on the Setup menu. An external editor or control panel can be used to perform multiple editing/output operations simultaneously.

### Flexible I/O Configuration Possible

Various I/O and control panel options are set according to the external equipment that is connected and the operating environment. The standard input and output configurations of the unit and when various optional boards are installed are shown below.

I/O signals	Configuration for standard equipment and when using optional boards
SDI video/audio	Standard equipment: 2 input/2 output, 3 input/1 output, 1 input/3 output
AES/EBU digital audio	Standard equipment: 2 input/2 output, 1 input/3 output, 3 input/1 output
Composite analog video	<ul style="list-style-type: none"> <li>BKMA-513 (AD/DA converter board) is needed</li> <li>Select from: 2 input/2 output, 2 input/1 output, 1 input/3 output</li> </ul>
Analog audio (four channels)	<ul style="list-style-type: none"> <li>BKMA-570 (analog audio expansion unit) is needed</li> <li>BKMA-513 (AD/DA converter board) is needed</li> <li>Select from: 2 input/2 output, 2 input/1 output, 1 input/3 output</li> </ul>
Time codes	<ul style="list-style-type: none"> <li>Standard equipment</li> </ul>

*For details on the basic options, refer to Section 1-4, "Optional Accessories" (page 1-4).*

## Linear editing functions

The MAV-555SS is equipped with the "BVE mode", an operation mode that provides the unit with linear editing capabilities. If the operation mode is switched to BVE mode, the MAV-555SS recording and playback ports are integrated, and the recorder can then be used as a recording/playback VTR. This mode allows the MAV-555SS to be connected to editing machines such as the BVE-600 or the BVE-2000 as a "recorder/player". Note that in other modes the MAV-555SS playback port can still be connected to editing machines such as the BVE-600 or the BVE-2000 as a "player".

The following functions are supported when using the BVE mode.

- Independent audio channel editing of up to 4 channels.
- Operation of the optional MAV-E-F555 editing panel and the MAV-E-D555 dial panel.
- Control by LTC from a BVE editor.
- Auto Assembly editing from a BVE editor.

## Ability to record asynchronous signals

By setting the standard signals of each recording port as input signals, input signals that are asynchronous with the reference signals can be recorded.

## 1-3 Changes from Ver. 1.00

### 1-3-1 Changes from Ver. 1.00 to Ver. 2.32

#### Improved BVE Mode

The following improvements were made.

- Addition of the Time Tracking function (automatic/manual).
- Ability to modify the recorder OUT point after recording is started, and the addition of the REC OFF function.
- Ability to insert text and graphics.
- Ability to edit material from a BUS signal.

- Ability to save cut point information.
- Ability to change the recording level with the Editing Fader Panel BKNE-1011, and to select the MAV-555SS (in SD mode) internal RP port or VTR for the recorder to mix or swap audio channels.
- Ability to insert video with voice over editing.
- Ability to make cuts using only the RP port.
- Addition of a function that backs up files being edited if the power to the MAV-555SS is accidentally cut.
- Ability to prohibit operations from the MAV-F555 background port in the setup menu.
- Ability to output editing point timing pulses from the GPI to an external device.

## 1-4 Optional Accessories

The following optional accessories are available for the MAV-555SS.

### Common to SS and SD modes

#### Control Panel BKMA-505

This is a dedicated control panel, which can be installed in the front blank panel of the MAV-555SS (interface cables are supplied). It controls recording, playback, and editing operations on this unit.

#### Control Panel Case Kit BKMA-506

This kit consists of a special case for the BKMA-505 control panel and a 10-m extension cable as a set. This kit makes it possible to use the MAV-555SS at a distance of up to 10m from the control panel.

#### AD/DA Converter Board BKMA-513

When this board is installed in the MAV-555SS, the input and output of analog composite video signals and analog audio signals becomes possible with the MAV-555SS.

- To be able to use analog audio, the BKMA-570 analog audio expansion unit is also necessary.
- The R3 port does not support analog input when the configuration is 3 input/1 output. Even if the BKMA-513 is installed, the analog inputs and outputs are 2 input/1 output.
- Cannot input analog SS signals in SS mode.

#### Analog Audio Expansion Unit BKMA-570

This expansion unit connects to the AUDIO I/O ports of the MAV-555SS with the supplied interface cable, and allows the MAV-555SS to use analog audio inputs and outputs.

- The BKMA-513 AD/DA Converter Board is required for analog audio input.

#### Rack Mount Kit RMM-555

When attached, the MAV-555SS can be fitted into an EIA standard 19-inch rack.

#### SD mode only

#### Video Effect Board BKMA-560/ Effect Expansion Board BKMA-561

When these boards are installed in the MAV-555SS, it allows you to edit materials that employ effect transitions.

*For more details about materials that employ effect transitions, see the BKMA-505 Control Panel Operation Manual.*

*For information about the patterns that can be used and other details, refer to the Video Effect Board BKMA-560 Operation Manual or Video Effect Board BKMA-561 Operation Manual.*

#### Editing Panel MAV-F555

When using the BVE editor, this editing panel can be used to perform file assignment operations, nonlinear editing operations, and operations through free ports that are not being used for editing.

#### Dial Panel MAV-D555

When the MAV-F555 is connected to the MAV-555SS, it can be used in conjunction with the MAV-D555 and BKNE-1011 to perform BVE editing operations, such as JOG dial operations, [PLAY], [SHTL], [REW], and [FF] operations, with all the ease of conventional BVE editing. Furthermore, nonlinear editing operations that were not possible with BVE editing can also be performed.

---

## Editing Fader Panel BKNE-1011

This panel can be used to adjust audio levels and make effect settings when performing nonlinear editing with the MAV-555SS and the MAVE-F555, MAVE-D555, or BKNE-1011.



# Chapter 2

## Names and Functions of Parts

### 2-1 Front Panel

The front panel of the MAV-555SS is in two sections:

- Meter panel (upper)
- Blank panel (lower)

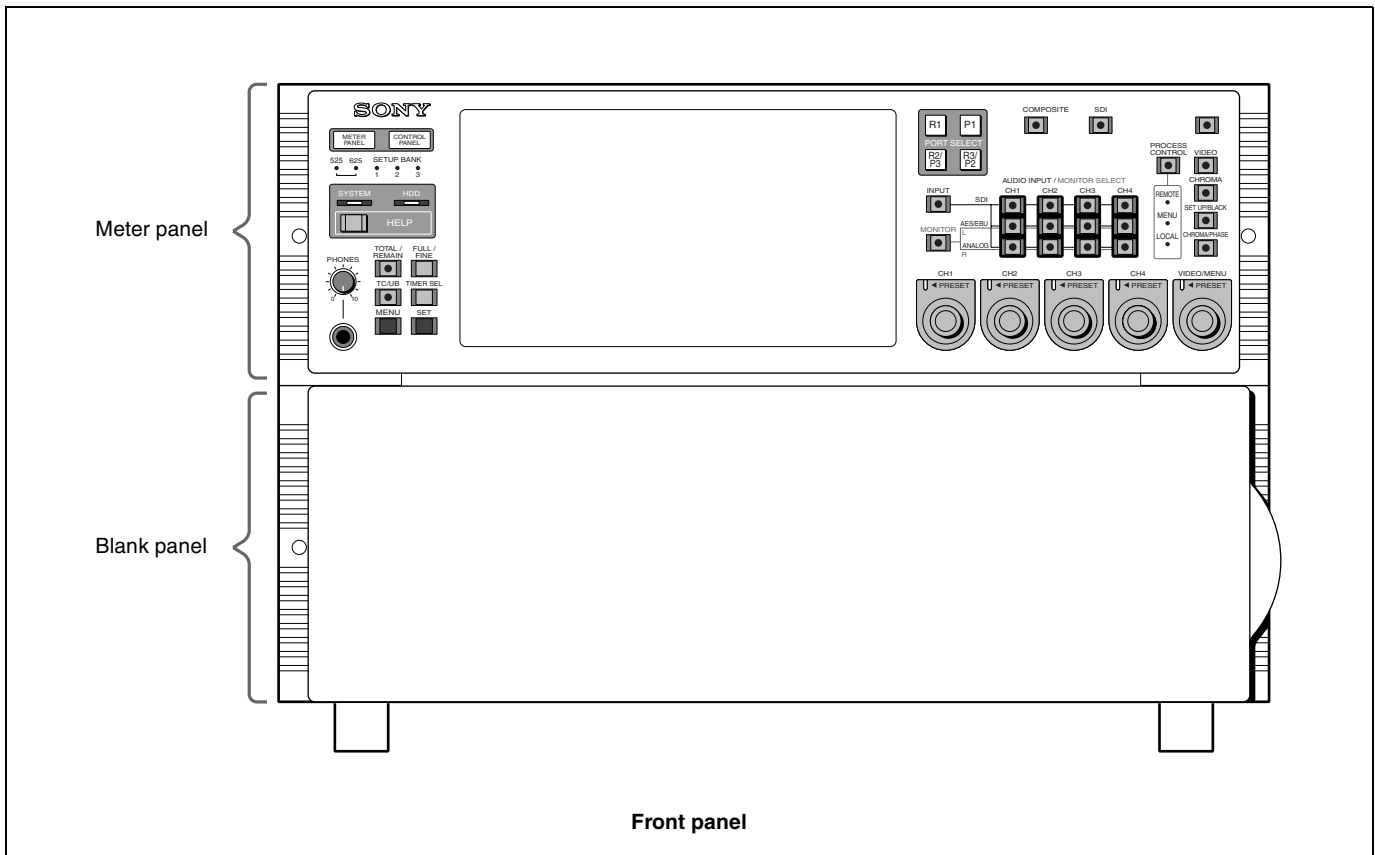

The blank panel in the lower part of the front panel accommodates the optional BKMA-505 Control Panel.

For details of this control panel, see Section 1-4, "Optional Accessories" (page 1-4).

## 2-1-1 Meter Panel

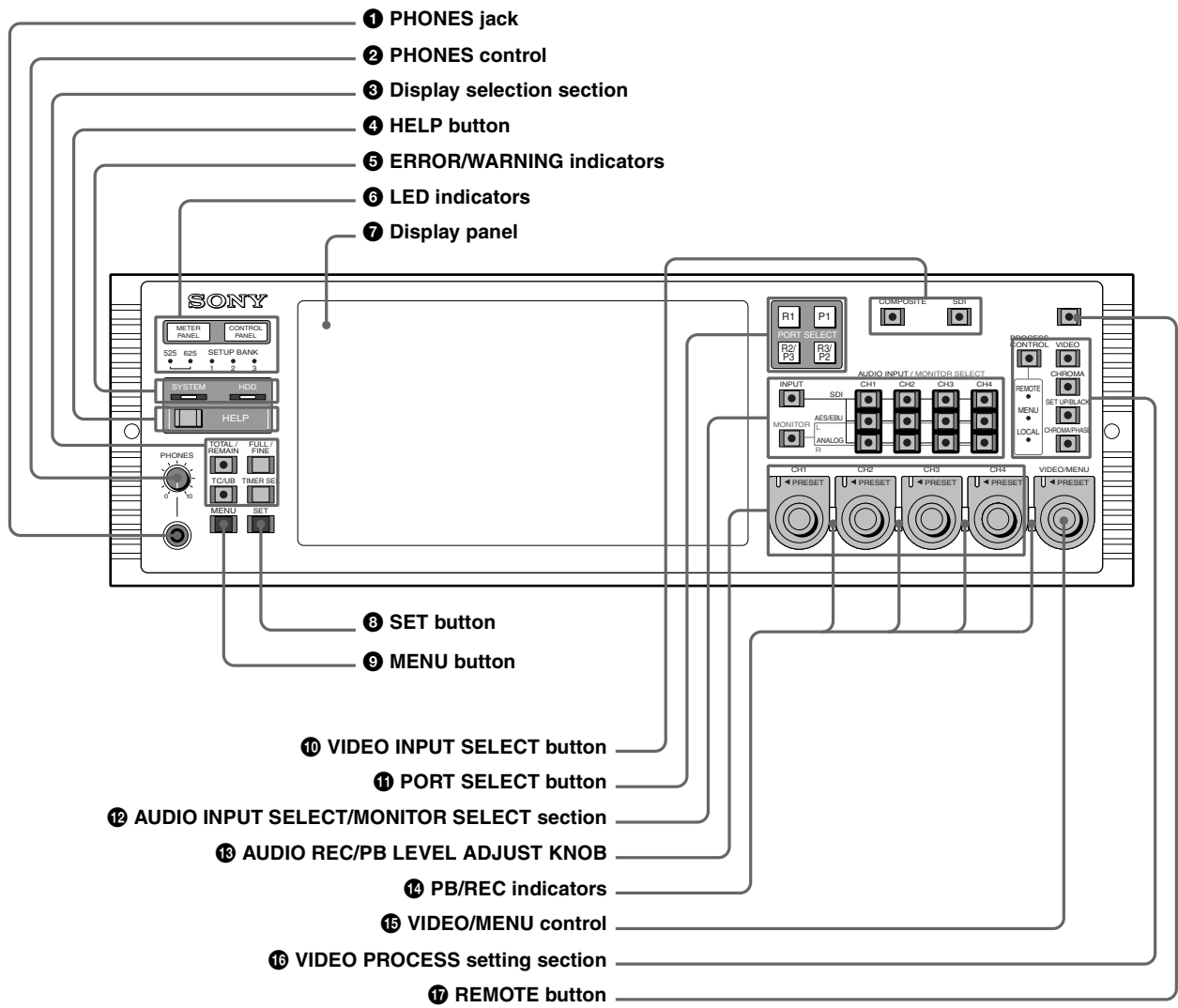

Meter panel



**1 PHONES jack**

By connecting stereo headphones with an impedance of 8 ohms to this jack, you can monitor the sound during recording, playback, and editing. This monitors the sound on the channels selected for monitor output on the currently selected port (using the PORT SELECT buttons (11) and AUDIO INPUT SELECT/MONITOR SELECT buttons (12)). Adjust the monitor volume with the PHONES control (2).

**2 PHONES control**

This adjusts the volume of the output from the PHONES jack.

**3 Display selection section****TOTAL/REMAIN (remaining) button**

Displays the total time of the files of material held on the HDD (Sys Total), the remaining available HDD capacity (Sys Remain), and the time remaining of the material currently being played/recorded for each port on the display panel (7). The button lights up when these are displayed.

**FULL/FINE button**

Selects the range of the audio level meter on the display panel (7) for the port currently selected by the PORT SELECT button (11).

**FULL:** The level meter range is -60 dB to 0 dB or -40 dB to +20 dB. A setup menu item determines which of these ranges is used (peak value 0 dB or +20 dB).

**FINE:** The level meter display range is magnified, to display 0.25 dB steps. If the audio level goes above the maximum display range, the top segment flashes; if the audio level goes below the minimum display range, the bottom segment flashes.

**TIMER SEL (time data display select) button**

This selects the type of time data displayed on the display panel (7) for the currently selected port. When normal time data (one of LTC, VITC, TM1, and TM2) is displayed, pressing the TIMER SEL button cycles the display through the sequence LTC → VITC → TM1 → TM2 → LTC ...

When user bit values are displayed, pressing the TIMER SEL button toggles between LTC and VITC user bit information.

**TC/UB (timecode/user bits) button**

When this button is pressed, turning it on, the user bit information in the timecode signal on the currently selected port appears on the display panel.

When the TIMER SEL selection being displayed is LTC or VITC, then the user bit information from the corresponding timecode signal is displayed.

Pressing the TC/UB button again when the user bit information is displayed turns the button off, and returns the display to normal timecode (i.e. not the user bits).

**4 HELP button**

If a fault occurs in the system (either Error or Warning level), press this button to display details of the problem on the display panel. If more than one error or warning condition exists simultaneously, press the HELP button repeatedly to step through the corresponding displays.

After displaying the error/warning information, the operation mode of the unit and the cumulative operating times appear on the display panel in sequence. Pressing the HELP button when no fault has occurred displays only this information.

**5 ERROR/WARNING indicators****SYSTEM indicator**

If a fault occurs in the system (either Error or Warning level), this indicator flashes red. During normal operation it lights green. When it is flashing red, you can press the HELP button (4) to display details of the problem on the display panel.

**HDD indicator**

This indicator flashes green during access to the HDD. If a fault (either Error or Warning level) occurs in a HDD, this indicator flashes red. When it is flashing red, you can press the HELP button (4) to display details of the problem on the display panel.

*When the ERROR/WARNING indicator blinks red, refer to the "Error Messages" appendix (page A-1).*

**6 LED indicators****Operating panel indicators**

These indicate which control panel can be operated: the METER PANEL indicator refers to the unit's meter panel, and the CONTROL PANEL indicator refers to the optional control panel (BKMA-505). Each indicator lights independently when the corresponding panel is enabled, and goes off when the panel is disabled. Further, operable panel settings can be enabled through the unit's system setup panel.

**525/625 indicators**

One of these lights, to show the number of scan lines in the television standard selected by basic menu item 010 (NTSC: 525 scan lines, 59.94 Hz field frequency; PAL: 625 scan lines, 50 Hz field frequency).

**MENU BANK indicators**

The indicator lights that corresponds to the currently valid SETUP MENU BANK. The SETUP MENU BANK is selected from the unit's system set up panel.

All the LED indicators light when reading from or saving to the memory card.

For details, refer to Section 2-2, “System Setup Panel” (page 2-6).

## 7 Display indicators panel

The display panel provides four sets of identical information, for each of the ports which can be used. The following figure shows one of these displays.

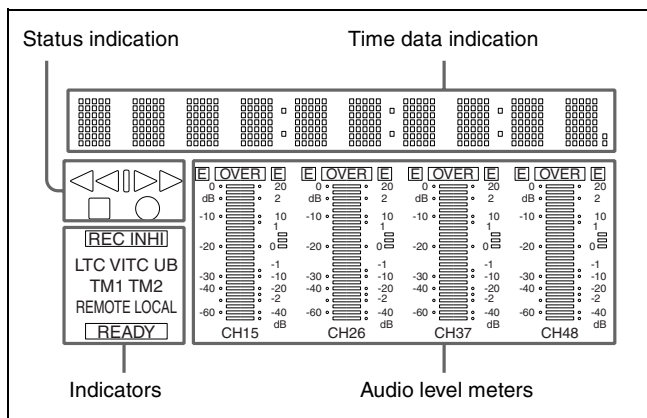

### Time data indication

This shows time data value for the corresponding port. When you press the MENU button it also shows setup menu items, and information about Error/Warning states.

### Status indication

This shows the operating status of the port, as follows.

- Play ..... ▶
- Stopped ..... ■
- Recording ..... ●
- Variable speed playback (FWD) at less than 1× speed ..... ▶
- Variable speed playback (REV) at less than 1× speed ..... ◀
- Fast forward or variable speed playback exceeding 1× speed ..... ▶▶
- Rewind or variable speed reverse playback exceeding 1× speed ..... ◀◀

### Indicators

These show the type of timecode displayed, the remote/local setting, whether recording is inhibited, and so forth.

- **REC INHIBIT**  
This appears when recording is inhibited on a recording port. The recording inhibit setting is carried out by a setup menu item.
- **Time data type**  
This appears as LTC, VITC, TM1, or TM2, according to the type of time data currently being displayed. When user bits from LTC or VITC are displayed, the UB indicator also appears.

- **Remote/local setting**  
This shows whether the port is set to LOCAL or REMOTE.
- **Port status**  
When the port is operating normally, the READY indicator appears.

### Audio level meters

These show the audio levels for each of the channels for the currently displayed port (either recording levels or playback levels as appropriate). When playing back material recorded with emphasis on, the “E” indicator appears for the corresponding channel. Either the FULL mode display (with two possible range selections) or the FINE mode display is available. To change the FULL/FINE selection, use the FULL/FINE button in the display selection section (3). Setup menu items determine the scale and headroom settings.

## 8 SET button

Press this button after changing a setup menu item.

## 9 MENU button

Pressing this button lights the indicator, and displays a setup menu item. Press once again to clear the menu display without changing the setting.

## 10 VIDEO INPUT SELECT buttons

Press one of these buttons, turning it on, to select the video input signal to the currently selected port.

**SDI:** Selects the serial digital video signal input to the SDI INPUT connector.

**COMPOSITE:** Selects the analog composite video signal input to the VIDEO INPUT (COMPOSITE) connector.

## 11 PORT SELECT buttons

These select the port used for time data display, audio/video input source selection, and other settings. The port selected by these buttons also determines the port output from MONITOR OUTPUT.

## 12 AUDIO INPUT SELECT/MONITOR SELECT section

### AUDIO INPUT SELECT/MONITOR SELECT buttons

Select the input audio signals or monitor output signals for the selected port. When the INPUT SELECT button is lit select the input audio signals, and when the MONITOR SELECT button is lit select the monitor output signals.

### INPUT SELECT button

Select the type and channel of the audio signal input to the currently selected port. Press this button, turning it on, then press the required AUDIO INPUT/

MONITOR SELECT button to assign the type and channel.

**SDI (CH1 to CH4):** Select audio signals input to the SDI INPUT connectors.

**AES/EBU (CH1 to CH4):** Select audio signals input to the AUDIO INPUT connectors.

**ANALOG (CH1 to CH4):** Select the audio signals that were input at the BKMA-570's ANALOG AUDIO INPUT connectors.

If no signal is present on the selected channel the corresponding button will flash.

### MONITOR SELECT buttons

Select the audio signals monitored on the MONITOR OUTPUT L and R connectors. Press these buttons, turning them on, then press selected of the AUDIO INPUT/MONITOR SELECT buttons to assign channels to the MONITOR OUTPUT L and R outputs. If you assign more than one of the channels (channels 1 to 4) to the same monitor output channels, the channels are mixed to form the monitor output.

### 13 AUDIO REC (recording)/PB (playback) LEVEL controls

These adjust the recording or playback levels for each of the four channels on the currently selected port. If the currently selected port is a recording port, these control the recording level, and if a playback port, the playback level. To make an adjustment, first push in the knob, so that the PRESET indicator goes off. While the PRESET indicator is lit, the level is fixed at the preset value, and cannot be adjusted.

### 14 PB/REC indicators

These light red when the currently selected port is a recording port, and green when the currently selected port is a playback port.

### 15 VIDEO/MENU control

While the indicator of the MENU button (9) is lit, this is used to select an item in the setup menu. For menu operation, please refer to Section 3-4, "Setup". While the indicator of the MENU button is off, this carries out the VIDEO PROCESS adjustment according to the VIDEO PROCESS setting mode currently selected in the VIDEO PROCESS setting section (16). The adjustment is only possible if both of the following conditions are met:

- The VIDEO PROCESS control mode is set to LOCAL
- The PRESET indicator to the top left of the knob is off

While the PRESET indicator is lit, the preset value for the currently selected VIDEO PROCESS setting mode is used, and adjustment is not possible. By pushing in the knob, the PRESET indicator goes off, and adjustment is then possible.

### 16 VIDEO PROCESS setting section

The four buttons on the right (VIDEO GAIN, CHROMA LEVEL, SETUP LEVEL/BLACK LEVEL, and CHROMA PHASE) are used to select the corresponding VIDEO PROCESS setting modes. Press one of the buttons, lighting the indicator, which shows that the corresponding VIDEO PROCESS setting mode is selected. The actual adjustment in each VIDEO PROCESS setting mode is made with the VIDEO PROCESS control (15). This adjustment applies only to the currently selected playback port.

### VIDEO GAIN button

Press this button, lighting the indicator, to allow the VIDEO PROCESS control (15) to control the video output level. The current setting of the video output level appears around the control knob.

### CHROMA LEVEL button

Press this button, lighting the indicator, to allow the VIDEO PROCESS control (15) to control the chrominance output level. The current setting of the chrominance output level appears around the control knob.

### SETUP LEVEL/BLACK LEVEL button

Press this button, lighting the indicator, to allow the VIDEO PROCESS control (15) to control the setup level (black level). The current setting of the setup level (black level) appears around the control knob.

### CHROMA PHASE button

Press this button, lighting the indicator, to allow the VIDEO PROCESS control (15) to control the hue (burst and chrominance relative phase). The current setting of the hue appears around the control knob. The button on the left (the PROCESS CONTROL button) and the three indicators (the PROCESS CONTROL MODE indicators) are used to set and indicate the VIDEO PROCESS control mode.

### PROCESS CONTROL button

This sets the VIDEO PROCESS control mode for the selected port. Each time you press the button, the control mode cycles through REMOTE, MENU, LOCAL, REMOTE, and so on. The current mode is shown by the PROCESS CONTROL MODE indicators.

### PROCESS CONTROL MODE indicators

These show the current VIDEO PROCESS control mode for the selected port.

**REMOTE:** The internal digital video processor is controlled with the HD Digital Video Controller HKDV-503/900 (sold separately).

**MENU:** Indicates that the internal video processor is under control of the Setup menu.

**LOCAL:** The internal video processor is controlled by the VIDEO PROCESS control (15) on this unit.

**LOCAL:** This unit is controlled only from the optional BKMA-505 Control Panel.

**17 REMOTE button**

This switches the currently selected port between the REMOTE and LOCAL modes. The button lights in REMOTE mode, and goes off in LOCAL mode.

**REMOTE:** This unit is controlled by the device connected to the REMOTE IN connector.

**2-1-2 Blank Panel**

The blank panel in the lower part of the front panel accommodates the optional BKMA-505 Control Panel. For details of this control panel, see Section 1-4, "Optional Accessories" (page 1-4).

**2-2 System Setup Panel**

To operate the system setup panel, raise the blank panel until it is horizontal.

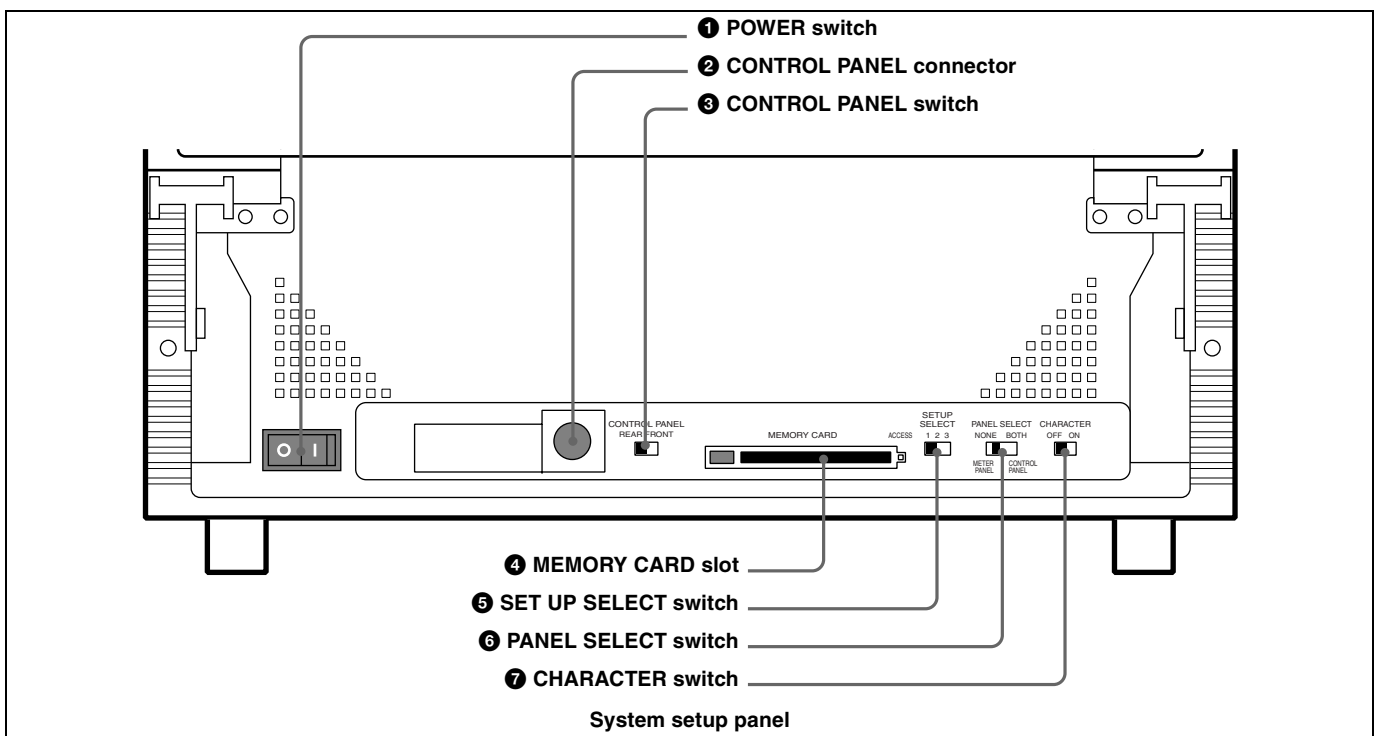
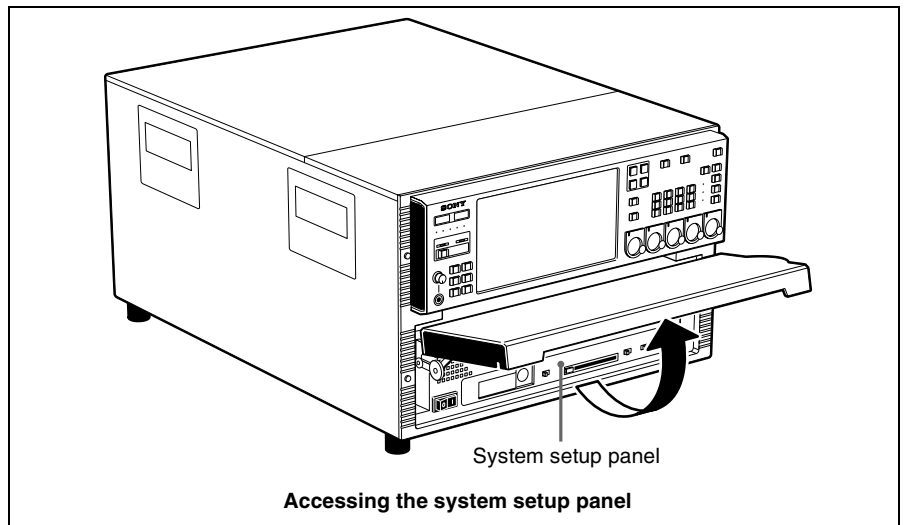

- 1 POWER switch
- 2 CONTROL PANEL connector
- 3 CONTROL PANEL switch

- 4 MEMORY CARD slot
- 5 SET UP SELECT switch
- 6 PANEL SELECT switch
- 7 CHARACTER switch

**1 POWER switch**

Set this to the ON position to power on this unit.

**2 CONTROL PANEL connector**

Connect an optional BKMA-505 Control Panel.

**3 CONTROL PANEL switch**

This selects whether an optional control panel is connected to the connector on the front panel or to the connector on the rear panel. If there are control panels connected to both connectors, this switch determines which is enabled.

**FRONT:** Enables the control panel connected to the connector on the front panel.

**REAR:** Disables the control panel connected to the connector on the front panel.

**4 MEMORY CARD slot**

Insert the memory card (sold separately) in this slot. Settings made on the Setup menu can be saved and read on a memory card as required.

To remove the card, press the eject button next to the slot.

**Note**

Do not eject the memory card while the ACCESS lamp is lit as this may damage the information on the memory card.

**5 SET UP SELECT switch**

This selects the number of the menu bank for this unit's settings. The menu bank selected by changing the switch setting becomes effective after the unit is restarted. However, changes are not effective if made while the power is off do not become effective the next time the power is turned on. In order to make the changes effective, either cycle the power off and on again, or reboot by means of the FAST REBOOT item (item number 027) in the basic menu. The currently valid menu bank is indicated by the MENU BANK indicators. You can change the settings of the current menu bank by pressing the MENU button to display the setup menu. To change the settings of any other bank, select the bank with the SET UP SELECT switch while the setup menu is displayed.

*For details of setup menus, see Section 3-4-1, "Basic Menu Settings" (page 3-18).*

**6 PANEL SELECT switch**

This switch enables or disables each of the meter panels fitted as standard to this unit and the operation control panel. The switch settings are as follows.

**NONE:** Both of the control panels are disabled.

**METER PANEL:** The meter panel only is enabled.

**CONTROL PANEL:** The control panel only is enabled.

**BOTH:** Both of the control panels are enabled.

**7 CHARACTER switch**

This switch selects whether or not timecodes and other character information is superimposed on the video signal output from the MONITOR OUTPUT connector.

**ON:** Superimposed information is output.

**OFF:** Superimposed information is not output.

The factory default setting is ON.

\* When the basic menu item ANALOG MONITOR SUPERIMPOSE (menu 008) is set to "inhibit", superimposition cannot be enabled from the ANALOG COMPOSITE (SUPER) connector.

# 2-3 Connector Panel

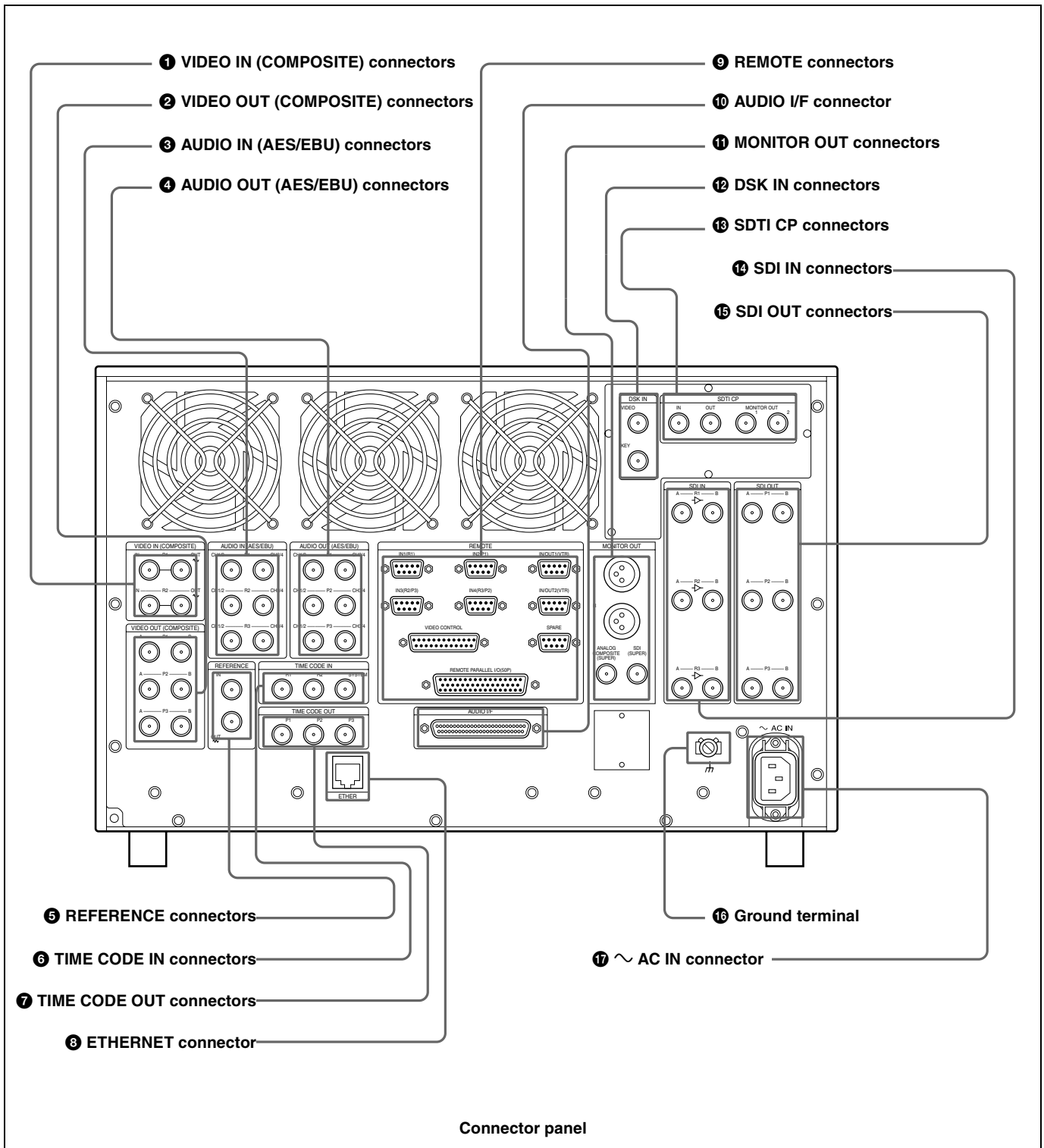

**1 VIDEO IN (COMPOSITE) connectors (BNC type)**

Input composite video signals (when the BKMA-513 option is installed). The connectors provide a loop-through connection. A maximum of two inputs are possible.

**2 VIDEO OUT (COMPOSITE) connectors (BNC type)**

Output composite video signals (when the BKMA-513 option is installed). A maximum of two outputs are possible.

**3 AUDIO IN (AES/EBU Digital Audio Input) connectors (BNC type)**

These jacks input digital audio signals in the AES/EBU format. Up to three inputs can be supported.

**4 AUDIO OUT (AES/EBU) connectors (BNC type)**

These jacks output digital audio signals in the AES/EBU format. Up to three outputs can be supported.

**5 REFERENCE connectors (BNC type)**

Input a reference video signal. This may be a video signal with chrominance burst (VBS) or a monochrome video signal (VS).  
The connectors provide a loop-through connection.

**6 TIME CODE IN (Time Code Input) connectors (BNC type)**

This is the input jack that is used when recording time codes from an external device. This jack connects to the time code output jack on the external device. The setting that indicates which of the inputs, either SYSTEM or R1 (R2), in each recording port is to be used for time code recording is made in the "LTC SELECT" expansion menu item (menu 670, 671). (However, when the configuration is 3 input/1 output, SYSTEM is always used at the R3 port.)

**Note**

The TIME CODE IN (SYSTEM) jack supports only a 1× time code signal. The error message "TM Warning LTC" appears if any other signal is input.

**7 TIME CODE OUT connectors (BNC type)**

These connectors output playback time codes.

**8 ETHERNET<sup>1)</sup> (10BaseT) connector**

In order to control the MAV-555SS from an external device that is connected via Ethernet, connect this connector to the external device with an Ethernet cable.

When using a LAN cable: For safety, do not connect to the connector for peripheral device wiring that might have excessive voltage.

<sup>1)</sup> Ethernet is a registered trademark of the XEROX Corporation.

**9 REMOTE (Remote Control Input/Output) Connectors****REMOTE IN connector (R1, P1, R2/P3, R3/P2, SPARE)**

When controlling the MAV-555SS through an external device, use the 9-pin remote control cable to connect this connector to the external device.

**REMOTE IN/OUT connector (1, 2)**

When controlling an external device from the MAV-555SS, use the 9-pin remote control cable to connect the external device to this connector.

**VIDEO CONTROL connector (D-SUB 25 pins)**

When controlling the internal digital video processor from a remote location, connect the HD digital video controller HKDV-503/900 (sold separately) to this connector.

*For details, refer to the installation manual.*

**REMOTE PARALLEL I/O connector (D-SUB 50 pins)**

The remote control signals from an external device are connected to this connector.

*For details, refer to the installation manual.*

**10 AUDIO I/F connector**

Connect to the optional BKMA-570 Analog Audio Expansion Unit.

*For information on the BKMA-570 connectors, refer to Section 2-4, "Analog Audio Expansion Box BKMA-570" (page 2-11).*

**11 MONITOR OUT connectors (BNC type, XLR-3-31)**

Output video and audio monitor signals for the port currently selected on the front panel. The XLR connectors (L/R) output the audio monitor signal, and the SDI and ANALOG connectors output a video signal including superimposed information.

**Audio monitor output connectors**

There are two audio outputs, L and R. The channels output are selected with the meter panel's MONITOR SELECT buttons and AUDIO INPUT/MONITOR SELECT buttons.

### **SDI (SUPER) connector**

This outputs a serial digital video/audio signal.  
The audio output signals output by this connector are as follows:

CH1: Audio monitor output. Same as the Lch signal.

CH2: Audio monitor output. Same as the Rch signal.

CH3: No output

CH4: No output

If the CHARACTER switch on the system setup panel is set to ON, timecode information and menu settings appear as text superimposed on the video signal.

### **ANALOG (COMPOSITE) (SUPER) connector**

This outputs an analog composite video signal.  
If the CHARACTER switch on the system setup panel is set to ON, timecode information and menu settings appear as text superimposed on the video signal.

#### **12 DSK IN connectors**

When the optional BKMA-560 is installed, the DSK VIDEO signal is input to the VIDEO connector and the DSK KEY signal is input to the KEY connector.

#### **13 SDTI CP connectors**

These connectors cannot be used.

#### **14 SDI IN (Serial Video/Audio Input) connectors (BNC type)**

The left jack inputs serial digital video/audio signals. When the power is on, signals that are input to the jack on the right is output through an internal circuit, making a bridge connection possible in SD mode. A maximum of three inputs are available.

#### **15 SDI OUT (Serial Video/Audio Input) connectors (BNC type)**

These jacks output serial digital video/audio signals. A maximum of three outputs are available.

#### **16 Ground terminal**

Connect to ground as required.

#### **17 ~ AC IN connector**

Connect to a power outlet using the power cord (1-776-997-11) (sold separately).



## 2-4 Analog Audio Expansion Box BKMA-570

When using analog audio input and output with this unit, connect the optional Analog Audio Expansion Box BKMA-570 to the AUDIO I/F connectors on the unit's connector panel, then connect to peripheral units via the BKMA-570.

The optional BKMA-513 is necessary for analog input and output.

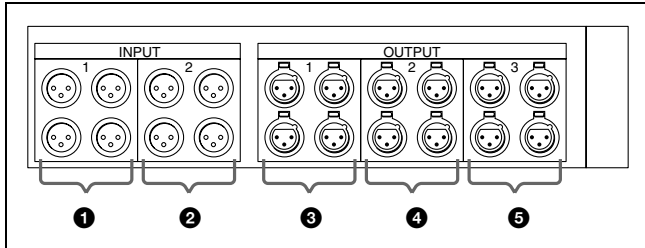

- 1 INPUT 1 (R1 input) connectors (XLR-3-31)**  
Analog audio inputs to the R1 port.
- 2 INPUT 2 (R2 input) connectors (XLR-3-31)**  
Analog audio inputs to the R2 port.
- 3 OUTPUT 1 (P1 output) connectors (XLR-3-32)**  
Analog audio outputs from the P1 port.
- 4 OUTPUT 2 (P2 output) connectors (XLR-3-32)**  
Analog audio outputs from the P2 port.
- 5 OUTPUT 3 (P3 output) connectors (XLR-3-32)**  
Analog audio outputs from the P3 port. (Planned for use with future functions.)

Input connectors (1 and 2) have LEVEL switches for each channel as shown below.

Channel LEVEL switches are set for use as follows:

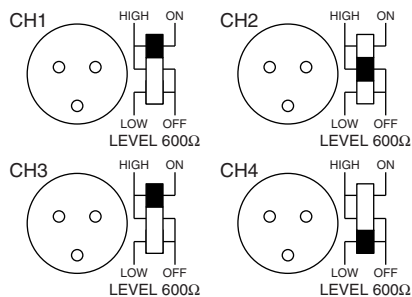

Audio Input		Switch Setting
Level	Impedance	
-60 dBu (microphone input)	High impedance (approx. 20 kΩ)	LOW-OFF (lower position)
+4 dBu (line voice input)	High impedance (approx. 20 kΩ)	HIGH-OFF (central position)
+4 dBu (line voice input)	600 Ω	HIGH-ON (upper position)



# Chapter 3 Preparations

## 3-1 MAV-555SS Modes

Before using the unit, you need to select a mode according to how you want to use the MAV-555SS. The available modes are described below.

### Motion modes (Two modes)

The motion modes allow you to select the MAV-555SS playback and recording speeds. When you want to record/playback at standard speed, select the SD mode (Standard Motion mode). When you want to record/playback at 3 times speed, select the SS mode (Sony Super Motion mode).

- SS mode: The MAV-555SS can simultaneously record signals input from Sony Super Motion or Philips cameras and perform playback at  $-3/3$  to  $3/3$  speed. In SS mode, you can only use the Panel and DTR+Panel operation modes. For details, see “Operation modes” below.
- SD mode: This is the mode to use under normal recording or playback conditions. It allows you to edit material recorded in SS mode and to play back such material at  $1/3$  speed. In SD mode, you can use all four operation modes. For details, see “Operation modes” below.

### Operation modes (Four modes)

The operation modes allow you to select how the MAV-555SS is controlled. There are four modes to select from.

- Panel mode: This mode allows you to control the MAV-555SS from the optional BKMA-505 Control Panel, Player port on the editor, or an external device.
- DTR+Panel mode: Replay and slow motion playback using one camera (Replay & Slow 1).
- DTR+DTR mode: Replay and slow motion playback using two cameras (Replay & Slow 2).
- BVE mode: The MAV-555SS is used as a recorder VTR.

This section contains examples of system configurations for each mode, as well as required option settings.

Select the motion mode from Basic menu item 042 PORT CONFIGURATION. Select the operation mode from Basic menu item 019 SYSTEM OPERATE CONFIGURATION. For details about the Basic menu, see Section 3-4, “Setup” (page 3-18).

For details about how to connect external devices according to the mode, see Section 3-2, “Connecting External Devices” (page 3-10).

## Panel Mode

### SS Mode (Sony Super Motion Mode)

In this mode you can record input signals from Sony Super Motion and Philips cameras, and perform playback simultaneously. This mode allows you to select the Panel and DTR+Panel operation modes.

The following illustration shows a three SDI input and one SDI Super Motion output system from a BVP-9500WS System (Sony Digital Super Motion Camera System) connected to the MAV-555SS.

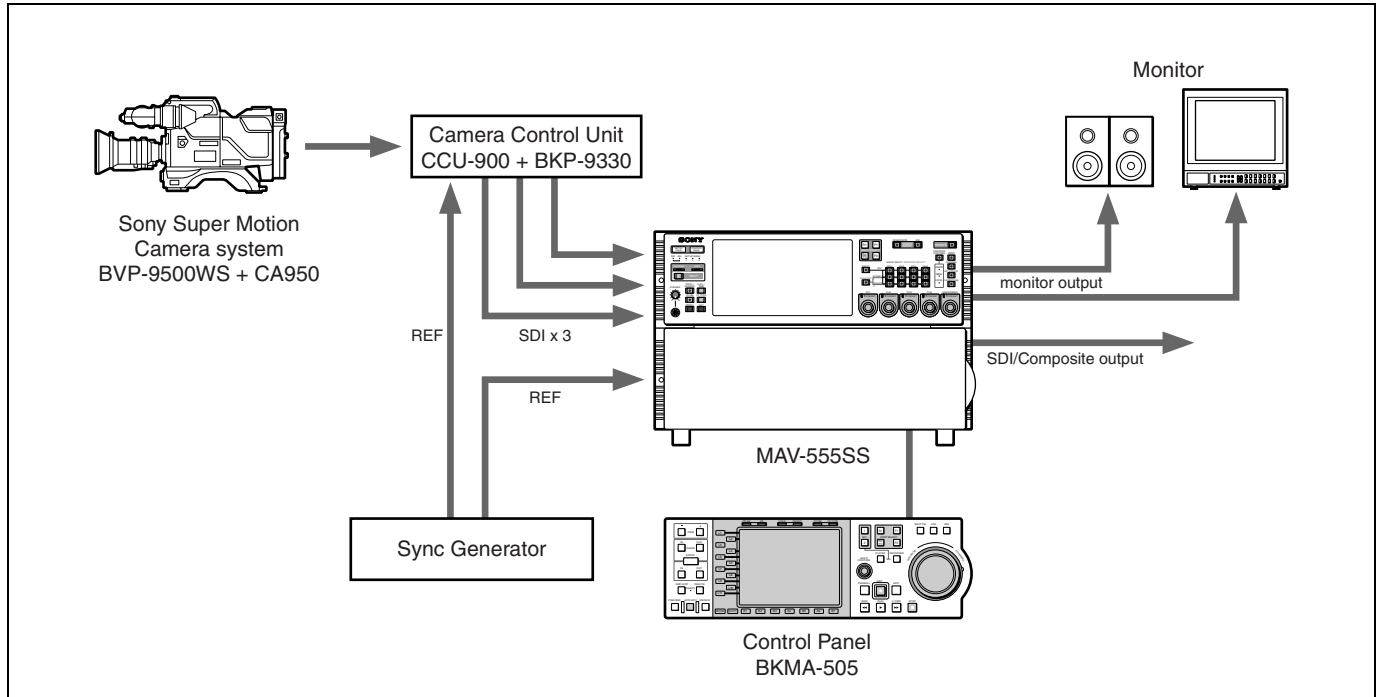

#### Note

- In SS mode, set the MAV-555SS expansion menu OUTPUT REF LOCK (menu 120) to REF, and REFERENCE SELECT (menus 349, 350, 351) to output ref.
- In SS mode, it is necessary to adjust the MAV setting of the Camera Control Unit (CCU-900). For details about this setting, refer to the CCU-900 Installation Manual, section 1-5-4, “VPR-57 Board (BKP-9330)”.

## SD Mode (Standard Motion mode)

In this mode, the input and output ports are controlled independently from the optional BKMA-505 Control Panel or from the Player port of the editor. However, an external device cannot be selected as the recorder.

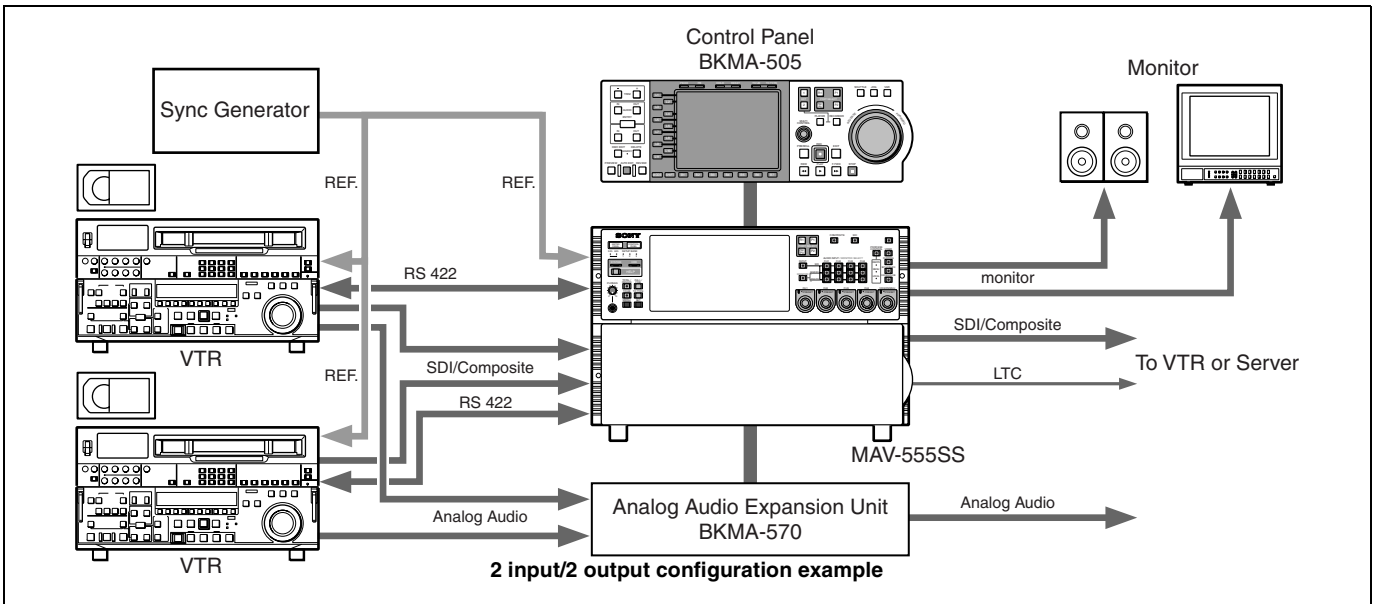

### Note

When editing, set expansion REFERENCE SELECT (menu 349, 350, 351) to “output ref”.

## DTR + Panel Mode

This mode allows a single camera to be used for a live relay, with replay and slow-motion playback during recording.

## SS Mode

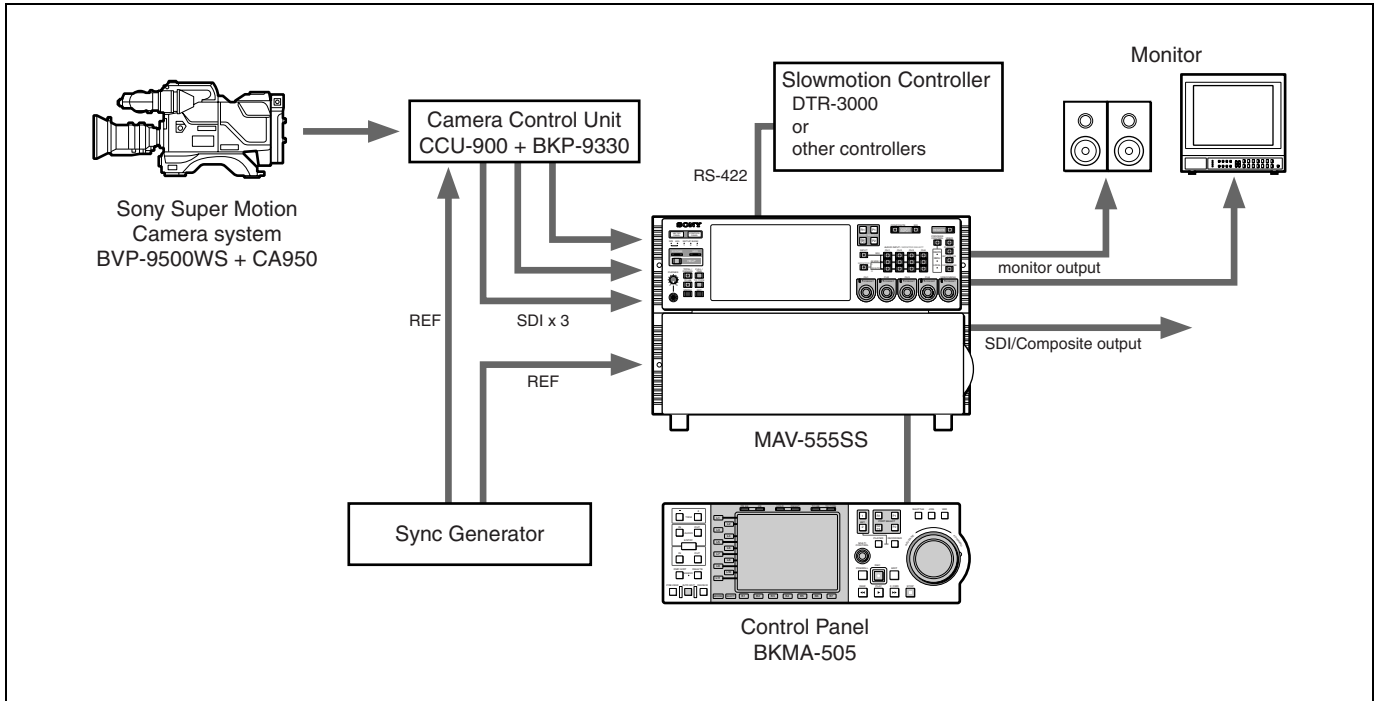

### Note

- In SS mode, set the MAV-555SS expansion menu OUTPUT REF LOCK (menu 120) to REF, and REFERENCE SELECT (menus 349, 350, 351) to output ref.
- In SS mode, it is necessary to adjust the MAV setting of the Camera Control Unit (CCU-900). For details about this setting, refer to the CCU-900 Installation Manual, section 1-5-4, “VPR-57 Board (BKP-9330)”.

## SD Mode

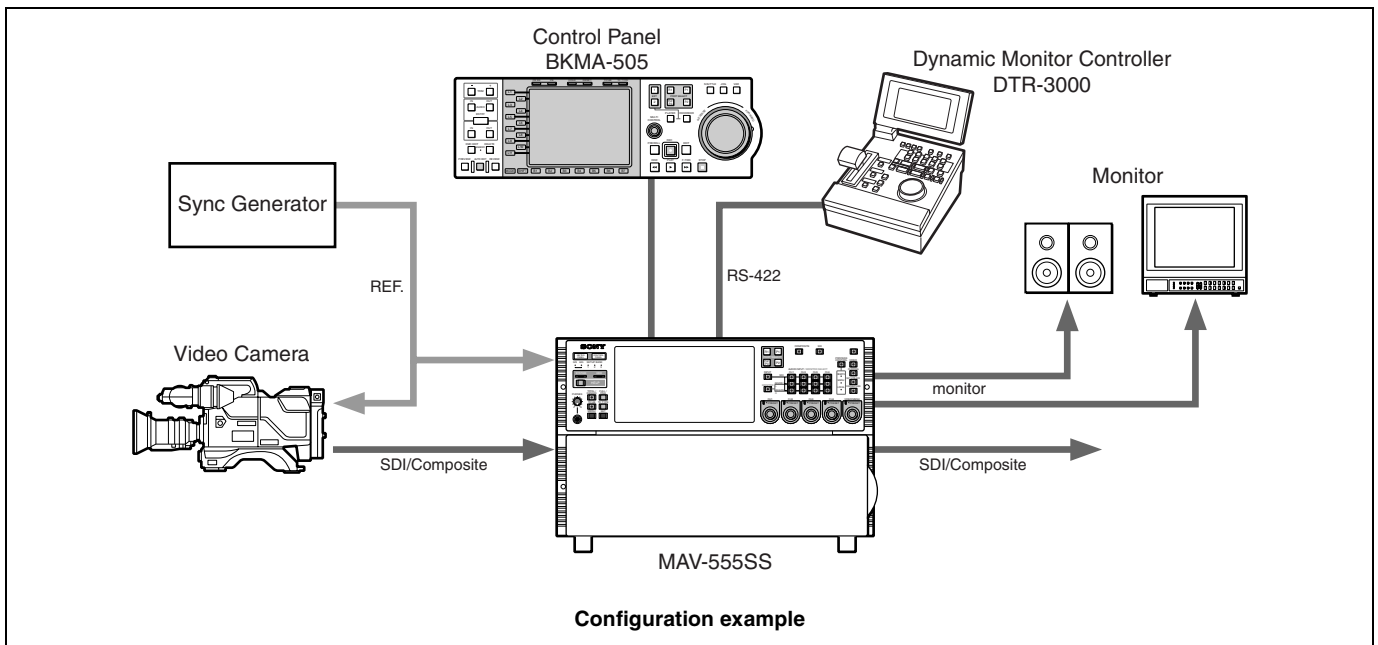

This example assumes ports R1 and P1 are controlled from a DTR-3000. Use the basic menu item LIVE DURATION (menu 034) to set the recording time for port R1.

*For details on basic menu settings and operation sequences, refer to Section 3-4, "Setup" (page 3-18).*

When using the BKMA-505 control panel, the following ports can be controlled through the control panel depending on the settings of the basic menu PORT CONFIGURATION (menu 042).

2 input/2 output ports	R2 and P2 ports
1 input/3 output ports	R2 and P3 ports

#### Notes

- When using a DTR-3000 with this unit, the DTR-3000 version must be CP:V01.30, VS:V01.20, or later. Further, the unit must be used in the DISK:INDIVIDUAL mode. For details, please contact the company from which you purchased the unit.
- To change from another operation mode to this mode, execute the -ALL ERASE (menu 099) basic menu item and then reboot.
- When the LIVE DURATION time value is changed, or when recording from the beginning of the recording area, existing material must be erased. Delete the "LIVE1" material in the Panel mode and reboot to this mode, or reboot after erasing all material using the -ALL ERASE (menu 099) basic menu item.
- Material recorded in this mode will be erased when this mode is again selected from the Panel mode.

## DTR + DTR Mode (SD mode only)

This mode allows two cameras to be used for a live relay, with replay and slow-motion playback during recording.

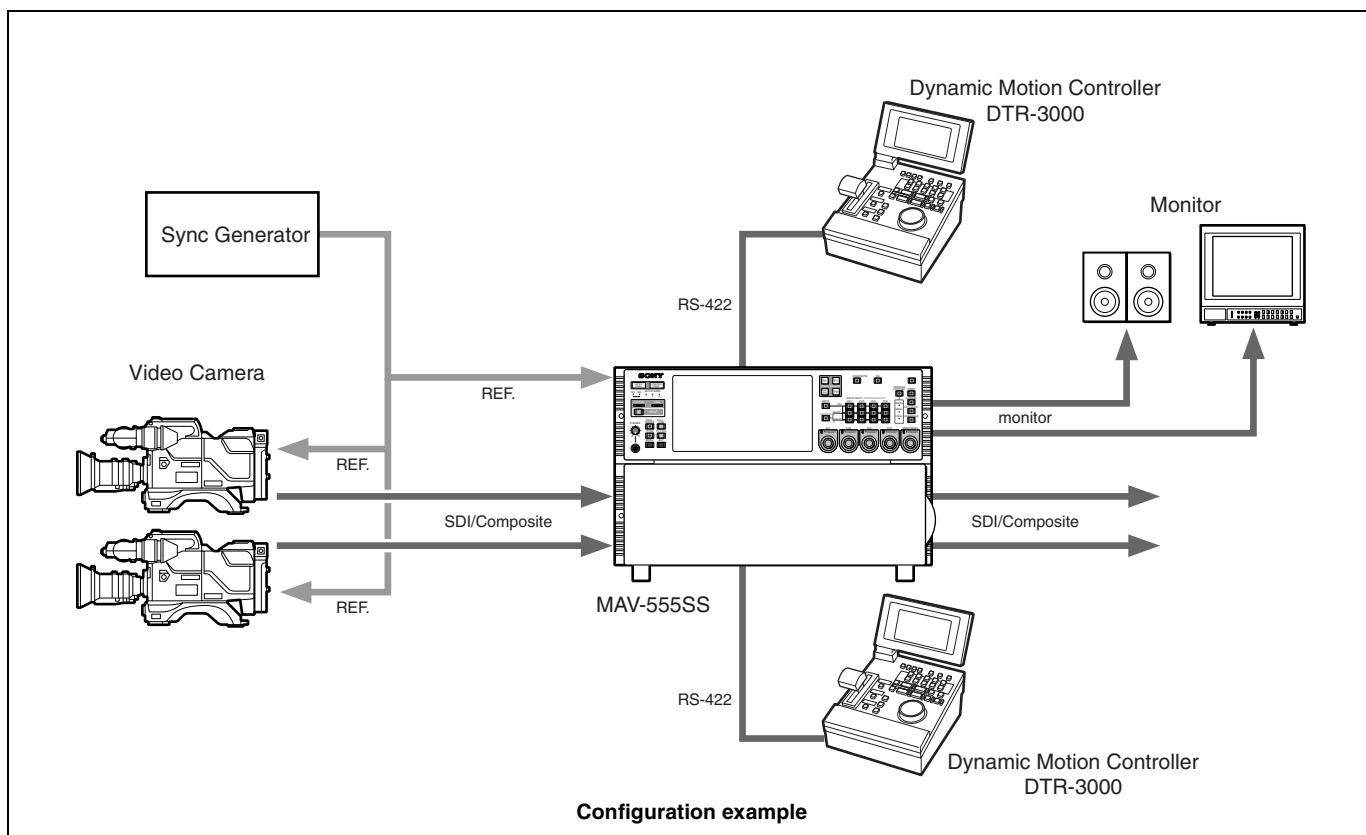

In this mode, the two groups of ports R1/P1 and R2/P2 are controlled from two DTR-3000 units.

Use the basic menu item LIVE DURATION (menu 034) to set the recording time for ports R1 and R2.

*For details on basic menu settings and operation sequences, refer to Section 3-4, "Setup" (page 3-18).*

### Notes

- When a DTR-3000 is used with this unit, it must be version CP:V01.30, VS:V01.20 or later, and this unit must be used in the DISK:INDIVIDUAL mode. For details, please contact the supplier of the unit or your Sony representative.
- To change from another operation mode to this mode, execute the -ALL ERASE (menu 099) basic menu item and then reboot.
- When the LIVE DURATION time value is changed, or when recording from the beginning of the recording area, existing material must be erased. Delete the "LIVE1" (and "LIVE2") material in the Panel mode and reboot to this mode, or reboot after erasing all material using the -ALL ERASE (menu 099) basic menu item.
- Material recorded in this mode will be erased when this mode is again selected from the Panel mode.



## BVE Mode (SD mode only)

In BVE mode, editing operations can be performed simultaneously while recording or playing back footage.

This mode makes nonlinear editing possible when the MAV-555SS and MAV-555SS special panel or VTR are connected (1), or linear editing when the MAV-555SS and a linear editing device (such as the BVE-600) or a VTR are connected. Examples of system configurations (1) and (2) are shown below.

### (1) 2 input/2 output configuration when the MAV-555SS special panel is connected

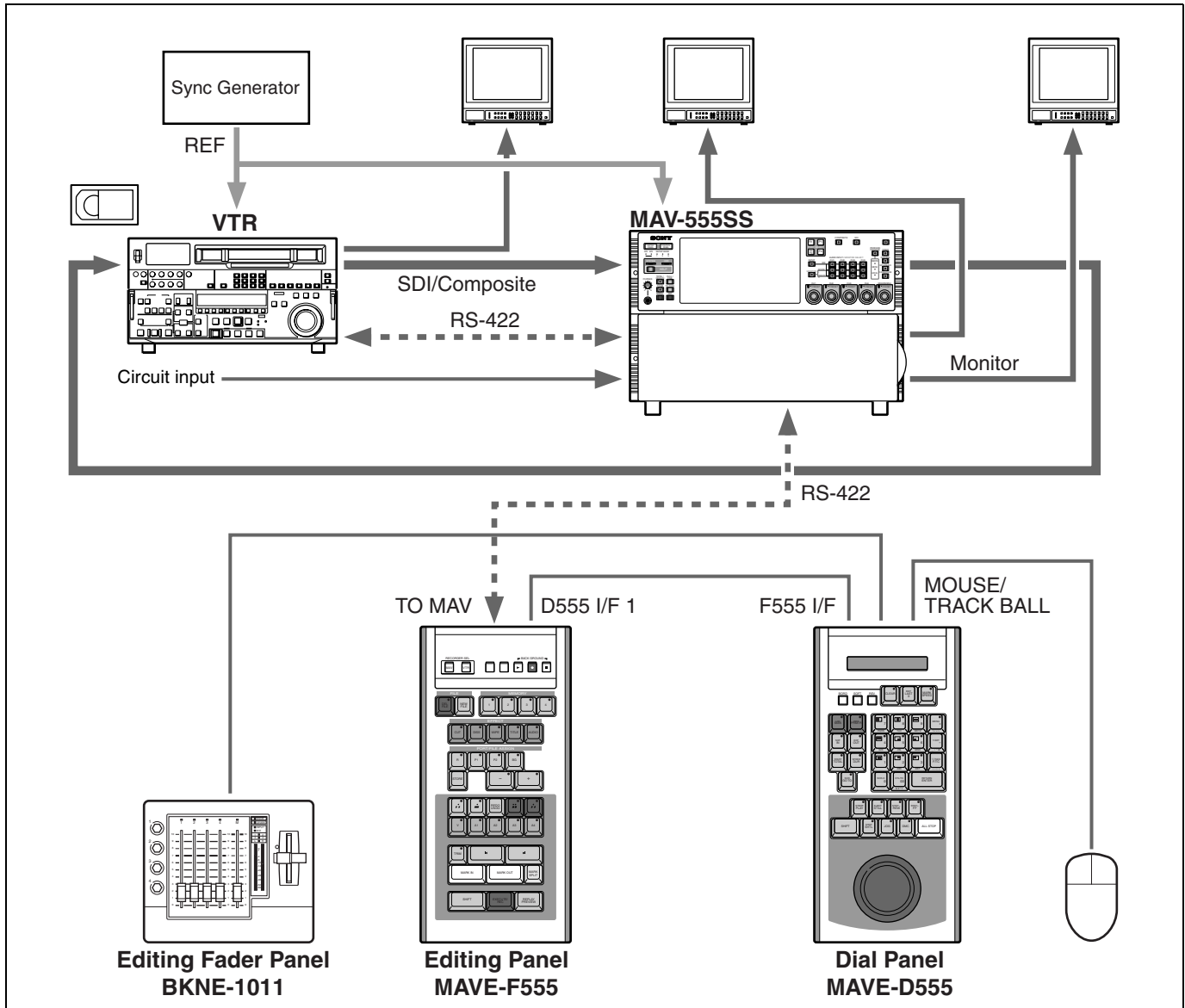

## (2) 2 input/2 output configuration when a linear editing device is connected

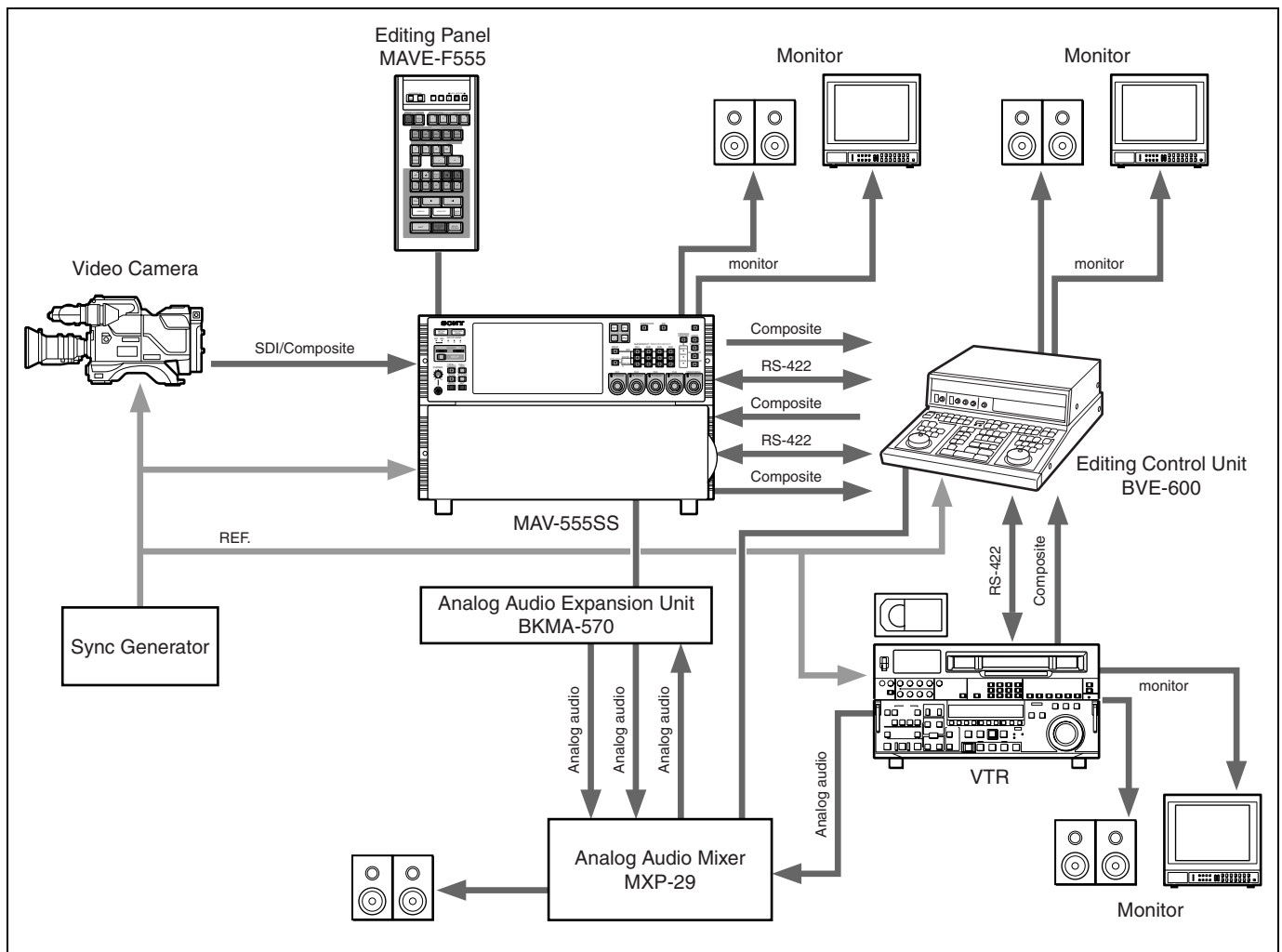

- In the BVE mode, the Record port (R1) and the Play port (P1) are combined, so the unit can serve as the VTR of a re-recorder (a combination recording and playback port is called an RP port). This means that recording at the R2 port while editing is possible.
- To begin editing, execute the Linear Edit New Material command from the optional BKMA-505 Control Panel to create a BLACK/MUTING file. This file is assigned to the RP port. The length of the initial file must be specified by LINEAR EDIT NEW FILE (menu 321) beforehand.
- When performing four-channel editing with a two-channel audio editor, select ANALOG AUDIO EDIT PRESET REPLACE (menu 307) on the expansion menu.
- For two-channel audio editing, use the BKMA-570 Analog Audio Expansion Unit. If not enough analog audio connectors are available for wiring of the system, channel 1 and 2 audio can be output from the channel 3 and 4 terminals by setting 821 AUDIO OUTPUT CHANNEL on setup menu 821.
- In BVE mode, only 2 input/2 output and 1 input/3 output configurations can be used.

- Specify the following as the editor VTR constants:

```

NTSC  BLOCK-1
      A0 70 00 3C 05 05 00 80
      BLOCK-2
      0C 04 FE 00 80 3C FF
PAL   BLOCK-1
      A1 70 00 3C 05 05 00 80
      BLOCK-2
      0C 04 FE 00 80 3C FF

```

*Please refer to Section 3-4, "Setup" (page 3-18) for details about setup contents and basic menu operations.*

#### **Notes**

- Apply the same reference video signal to the VTR, editor, and the MAV unit, set MAV-555SS expansion menu OUTPUT REF LOCK (menu 120) to REF and REFERENCE SELECT (menus 349, 350, 351) to output ref.  
*Please refer to Section 3-3, "External Synchronization of Output Video Signals" (page 3-17) and Section 3-4, "Setup" (page 3-18).*
- Collection is performed from the controller connected to the R2 port, the optional control panel (BKMA-505), the editing panel (MAVE-F555), etc.
- File assignments made to the RP port or the P2/P3 port are made from the optional control panel (BKMA-505), the editing panel (MAVE-F555), etc.
- When configured with an editor that uses analog composite signals, the optional BKMA-513 AD/DA Converter Board is necessary. When configured with an analog audio mixer (such as MXP-29), the optional BKMA-570 Analog Audio Expansion Unit is also required.
- In BVE mode, the maximum variable mode playback speed is  $\pm 1 \times$  normal speed; you cannot playback at double speed.

# 3-2 Connecting External Devices

This section illustrates the connections of this unit to other devices, in the operation modes described in Section 3-1, "MAV-555S Modes".

## 3-2-1 Connections with the Panel Mode

### Connecting to digital devices (SS mode)

The following example illustrates how to connect a Sony BVP-9500WS to the MAV-555SS.

**Note**

- To connect an analog VTR you need an optional AD/DA Converter Board (BKMA-513) and Analog Audio Expansion Unit (BKMA-570).
- The SS-A, SS-B, SS-C, cables must be no longer than 10 meters.
- In SS mode, set the MAV-555SS expansion menu OUTPUT REF LOCK (menu 120) to REF, and REFERENCE SELECT (menus 349, 350, 351) to output ref.

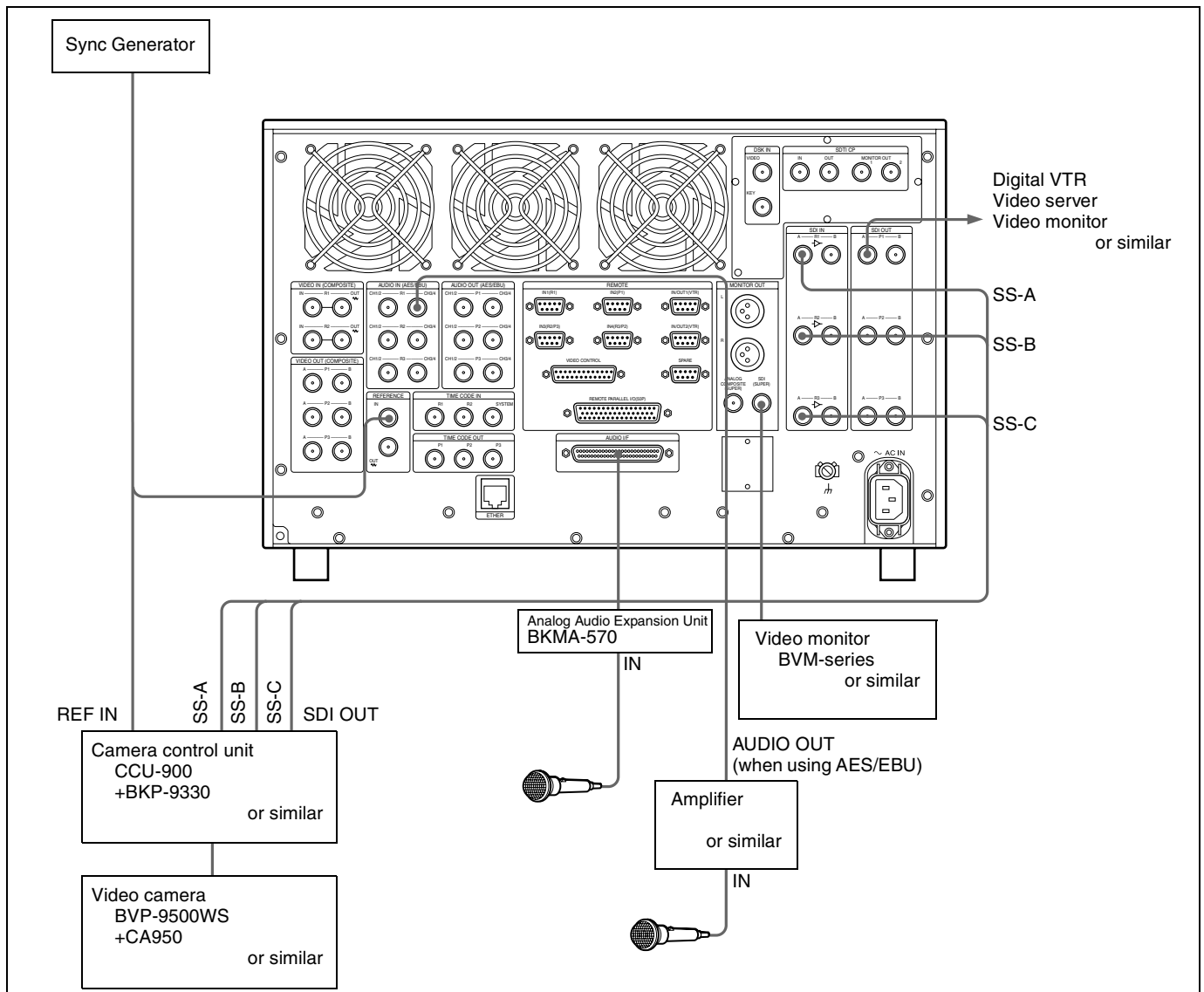

## Connecting to digital devices (SD mode)

The following example illustrates connection to a digital VTR, such as one from the Sony DVW series.

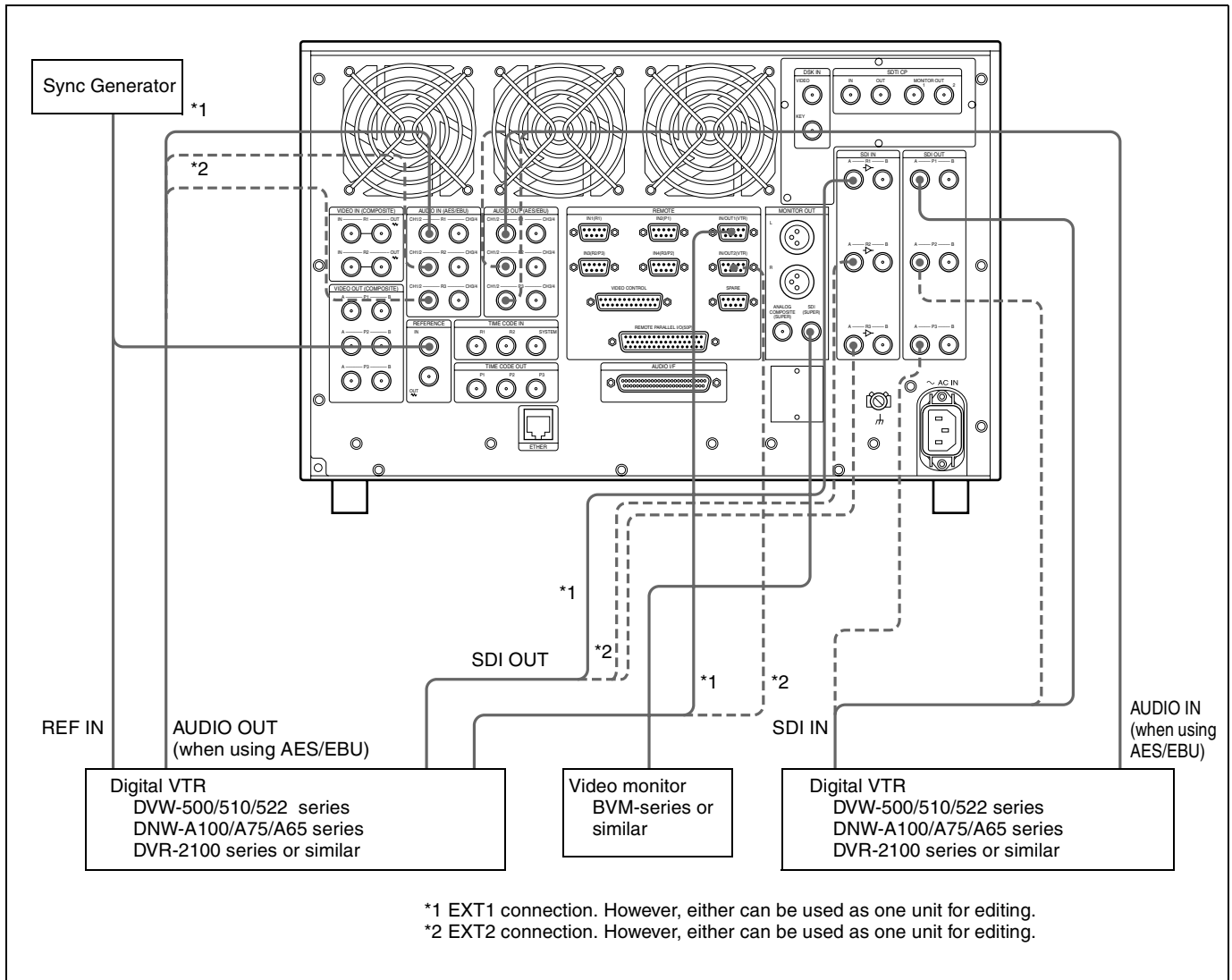

## Connecting to analog devices (SD mode)

The following options are required in order to connect an analog VTR to the MAV-555S: AD/DA Converter Board BKMA-513 and Analog Audio Expansion Unit BKMA-570.

### Note

When using a 3 input/1 output configuration, the R3 port does not support analog input.

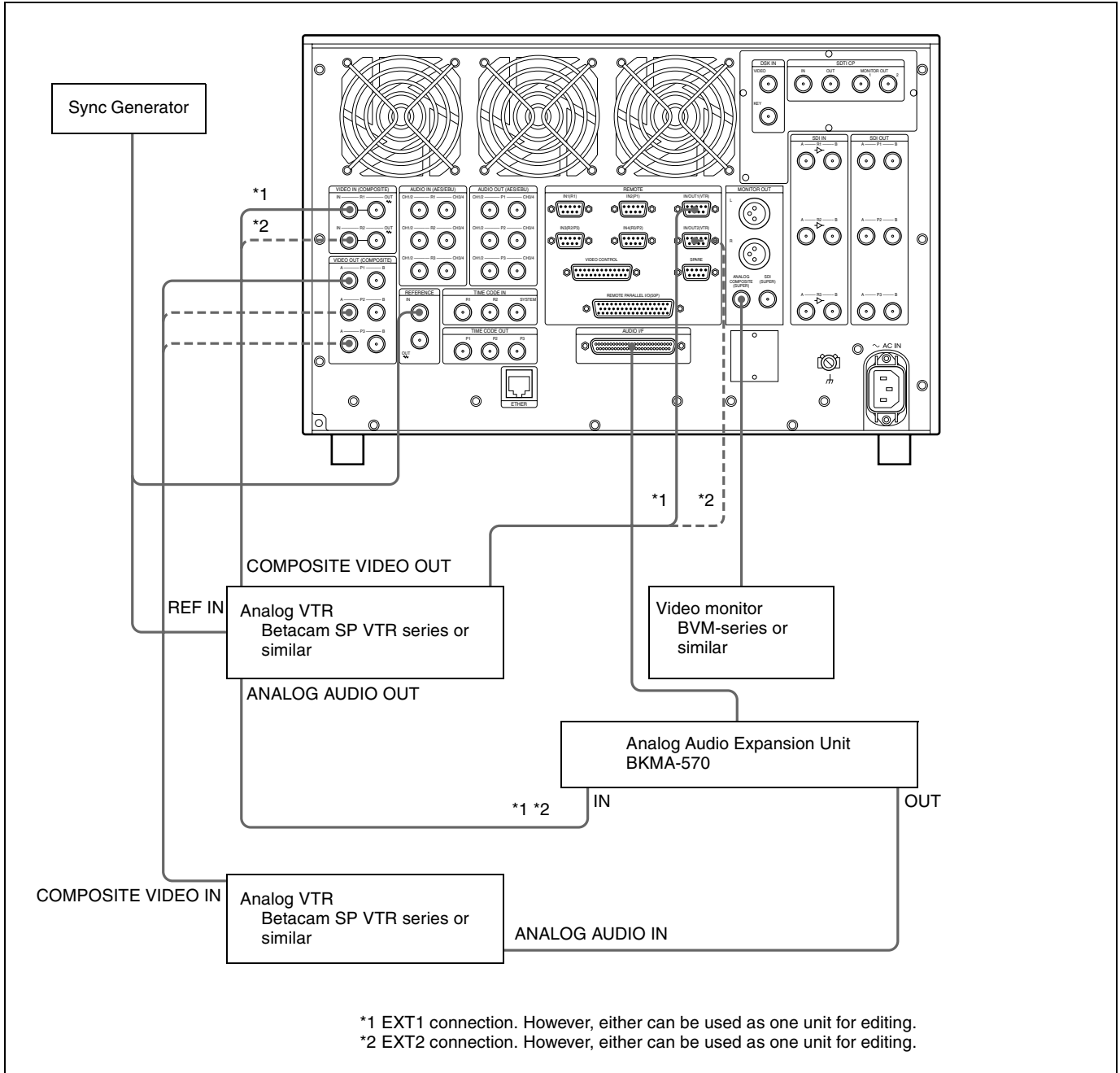

## 3-2-2 Connections with the DTR + Panel Mode

### Connecting with the DTR+Panel mode (SS mode)

The following example illustrates how to connect a Sony BVP-9500WS to the MAV-555SS.

#### Note

- To connect an analog VTR you need an optional AD/DA Converter Board (BKMA-513) and Analog Audio Expansion Unit (BKMA-570).
- The SS-A, SS-B, SS-C cables must be no longer than 10 meters.
- In SS mode, set the MAV-555SS expansion menu OUTPUT REF LOCK (menu 120) to REF, and REFERENCE SELECT (menus 349, 350, 351) to output ref.

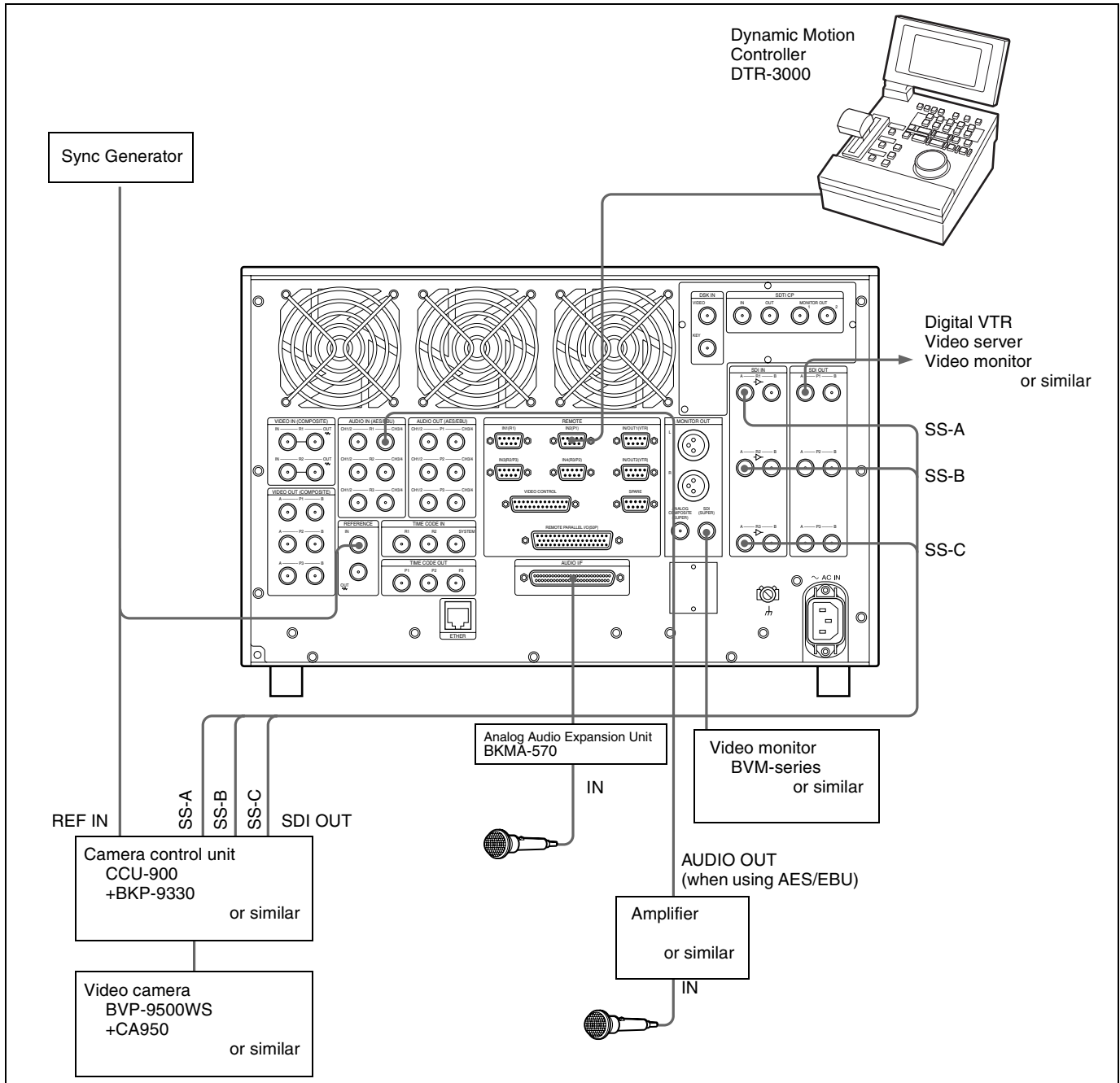

# Connecting with the DTR+Panel mode (SD mode)

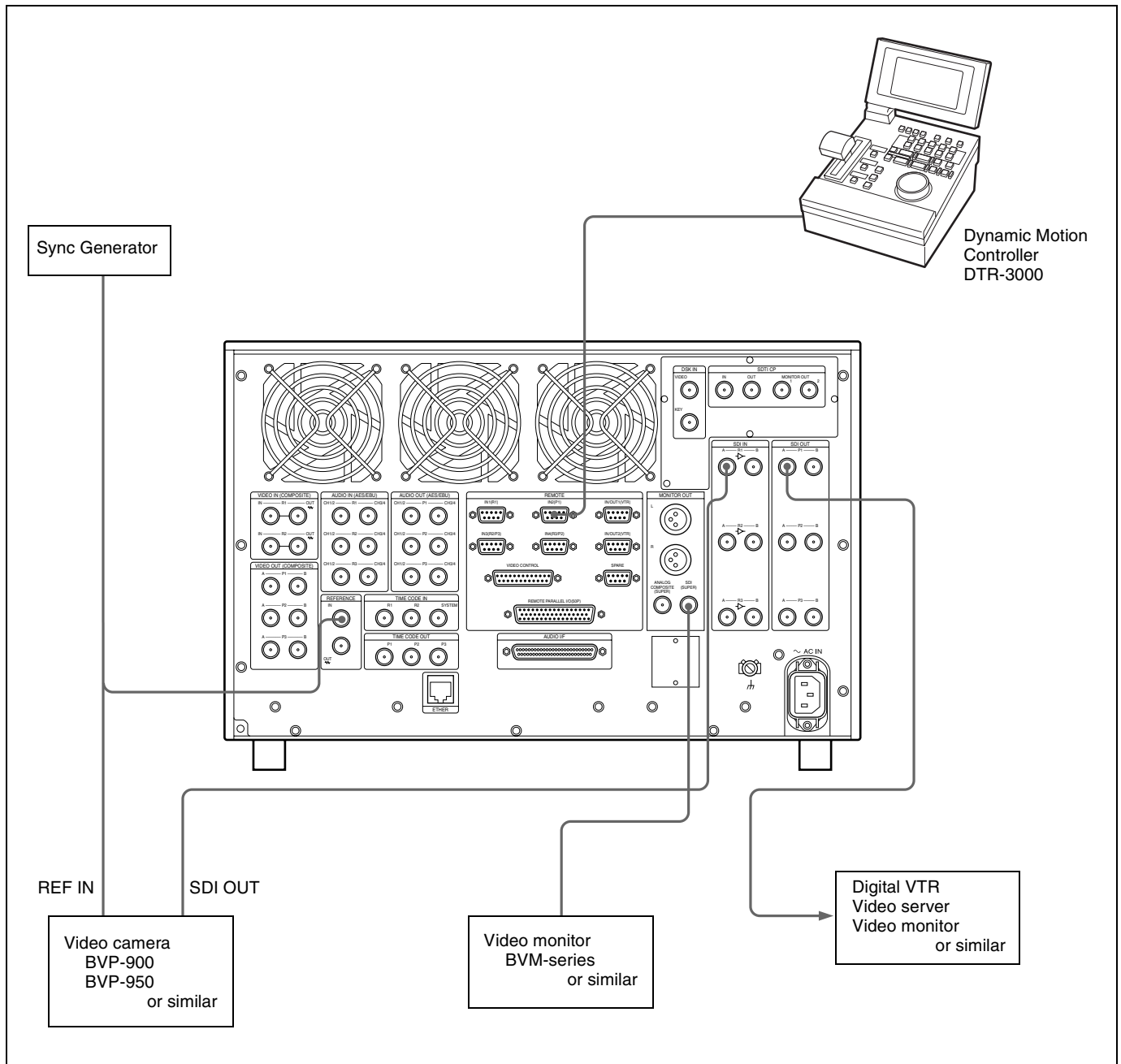



### 3-2-3 Connections with the DTR + DTR Mode

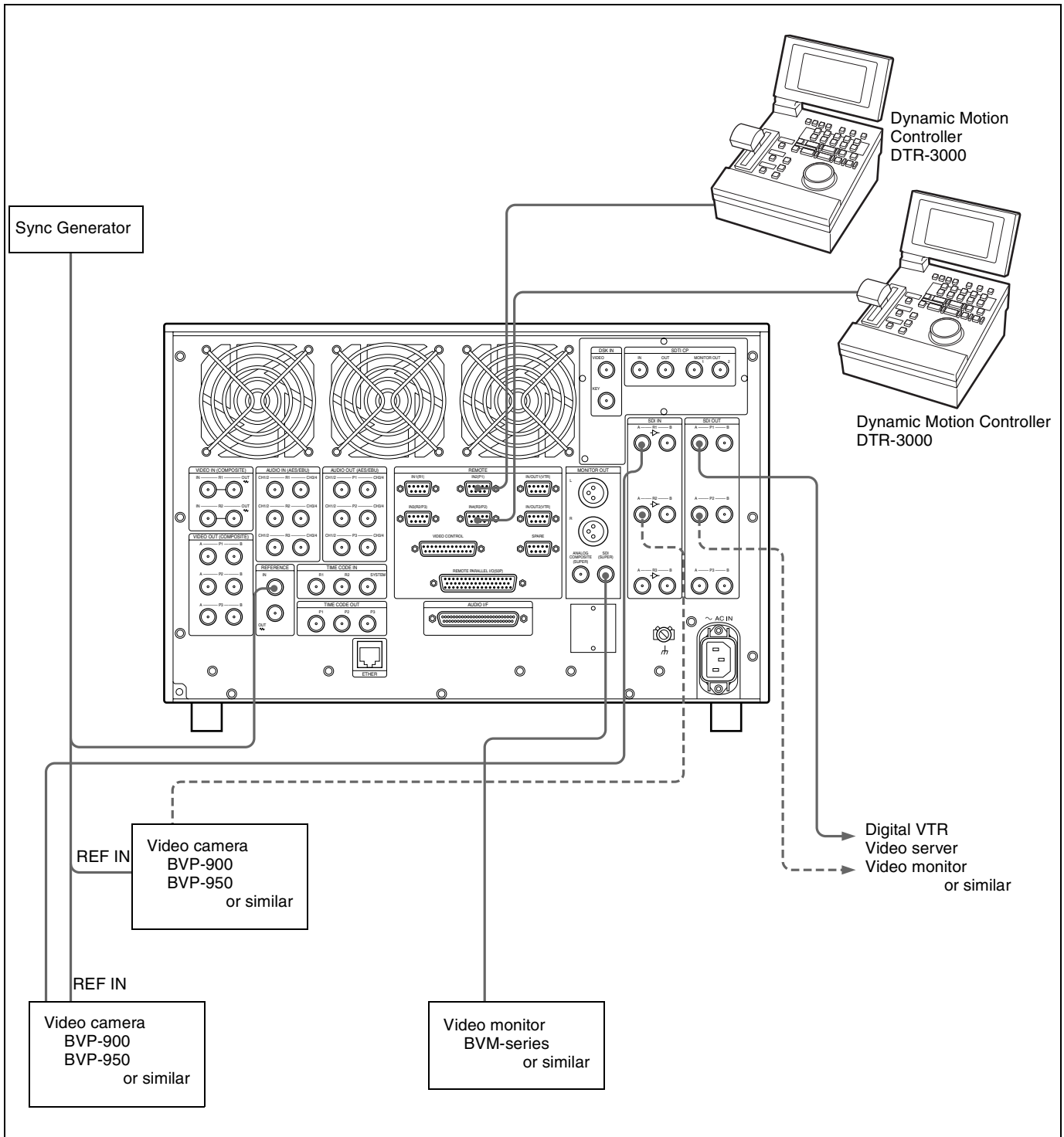

### 3-2-4 BVE Mode Connections

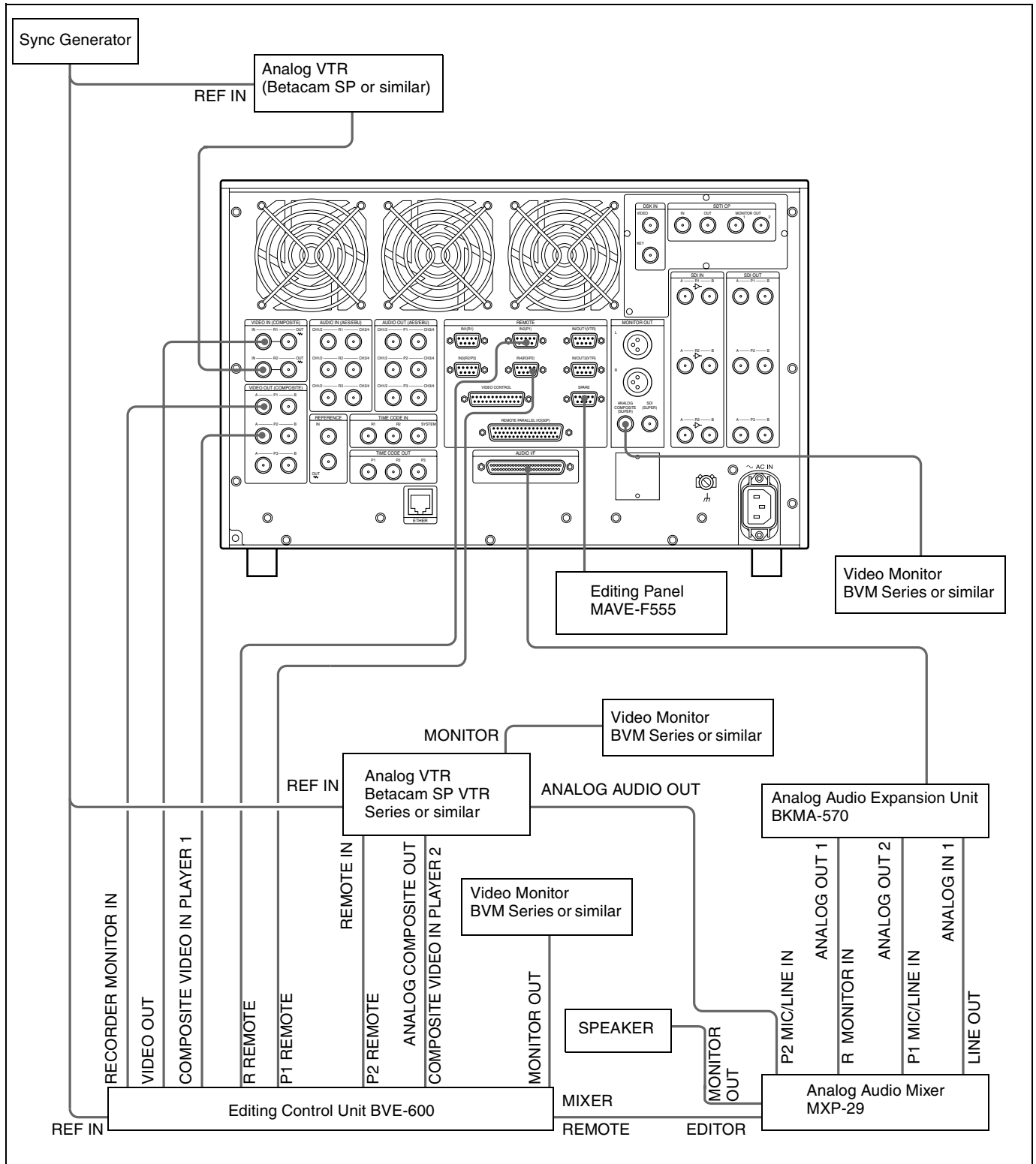

**Note**

When configured with an editor that uses analog composite signals, 2 each of the optional BKMA-513 AD/DA Converter Board is required. When configured with an analog audio mixer (such as MXP-29), the optional BKMA-570 Analog Audio Expansion Unit is also required.

# 3-3 External Synchronization of Output Video Signals

Output image signals are synchronized with either the reference video signal input to the REF.IN connector, or the video signal input to R1 and R2. External synchronization varies as follows according to the settings of Expansion menu item OUTPUT REF LOCK (menu 120).

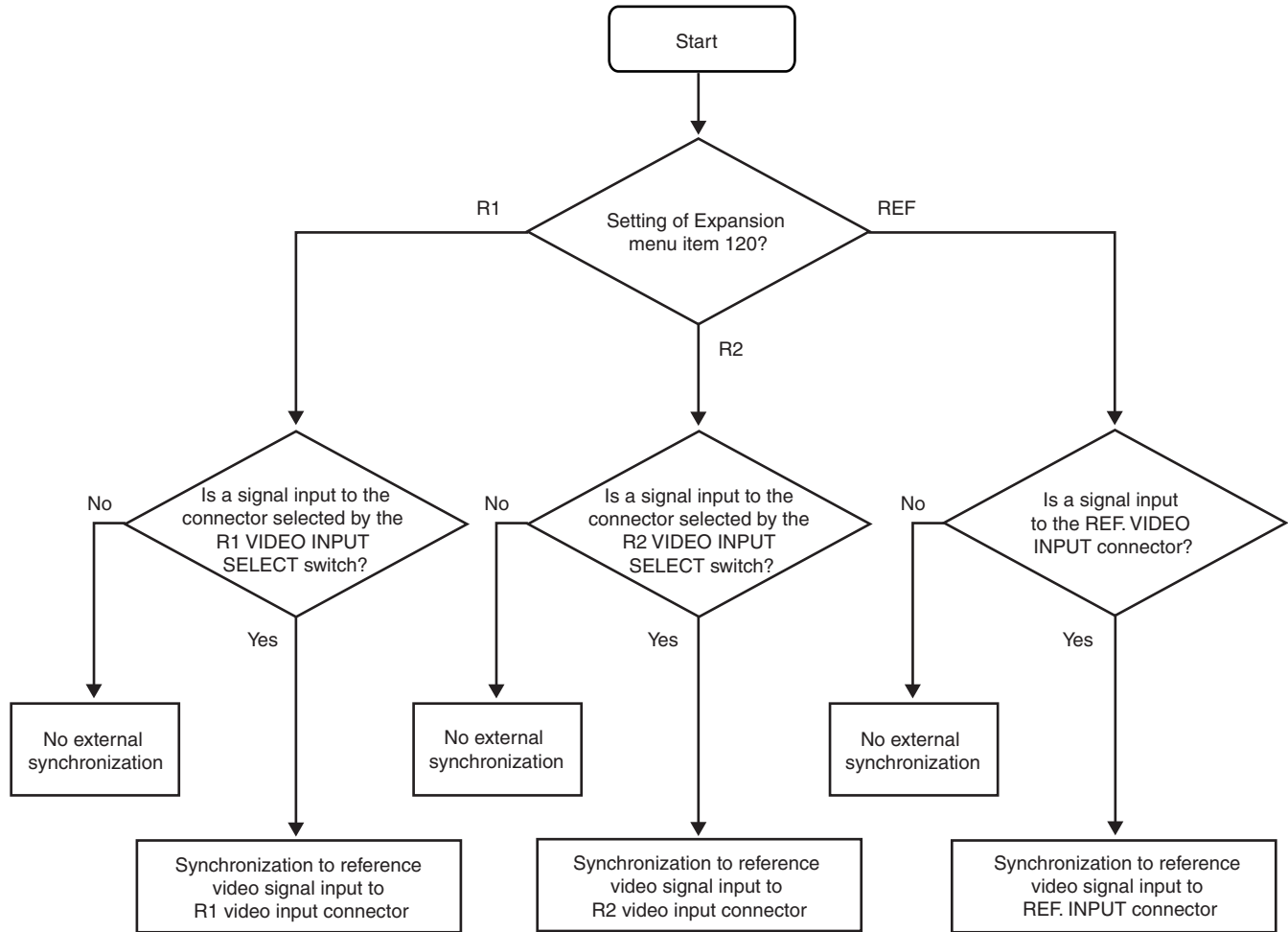

**Note**

In SS mode, set the MAV-555SS expansion menu OUTPUT REF LOCK (menu 120) to REF.

# 3-4 Setup

Carry out the principal settings required before using this unit by menu operations.

The setup menus on this unit consist of the Basic menu and the Expansion menu, and these menus include the following items.

- Basic menu.....Application selection, content and position of superimposed text information, 525 (NTSC) or 625 (PAL) selection, HDD and RAID settings, bit rate selection, and other settings.
- Expansion menu....REC INHIBIT settings for individual ports, audio/video control, and other settings.

Settings made in the Basic and Expansion menus can be saved on a memory card (sold separately) and read as required. All banks (bank 1 to bank 3) can be saved at once, or each bank can be saved and read separately. Up to 10 banks can be saved or read.

The following memory cards (sold separately) can be used:

- Supported format
- ATA flash card: PCMCIA 2.0 (JEIDA 4.1), PCMCIA ATA 1.02, Type 2-compatible
- Capacity: 8 MB or higher
- Recommended product: "MemoryStick" + adapter
- MSA-8AN (8 MB) "MemoryStick"
- MSAC-PC2N PC card adapter

### Note

Data recorded with the MAV-555/555A is incompatible with the MAV-555SS, and vice-versa.

This section lists the contents of the menus, and describes how to make settings.

## 3-4-1 Basic Menu Settings

### How to Read the Tables

- In the "Settings" column, values enclosed in squares are defaults.

### About the Display

- The monitor screen and time data display on the front panel show the item number, the item name, and the setting value.

- The upper and lower dots of the colon displayed between the item number and name may either flash or remain lit, indicating the following conditions.

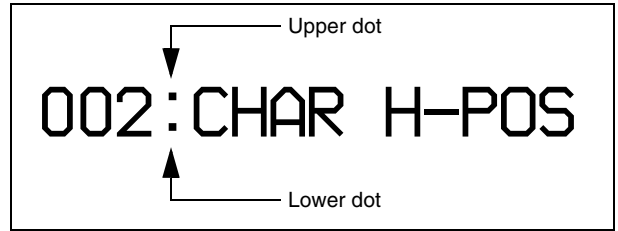

- (1) Items that take effect immediately or items that take effect after the system has been rebooted. For items that take effect immediately, the lower colon dot lights up, and for items that take effect after rebooting, the dot flashes.
- (2) Items that can be set for each bank or items with a common setting for all banks. When items can be set for each bank, the upper colon dot lights up, and when items have a common setting for all banks, the dot flashes.

Example: 002:CHAR H-POS indicates an item that can be set independently for each bank, which setting takes effect immediately.

010 -525/625 indicates an item that has a common setting for all banks, which setting takes effect only after rebooting.

- On the front panel display, the upper dot is displayed alone to indicate items that can be set for each bank and which become effective upon rebooting. On the monitor screen, this is indicated by a dot displayed in the center.
- The letters 'B' and 'I' appear at the upper right of the setup menu on the monitor screen. 'B' indicates that the selected setting item can be set for each BANK independently, and 'I' indicates that the selected setting takes effect immediately.
- The distinction between "B" and "I" is also indicated in the "Item number" column.

### Note

If the power is turned off while the menu is open, please note that changes made nonetheless become effective.

### Basic menu items

Item number	Display indication	Settings
001 BI	PREROLL TIME	This item sets the pre-roll time when performing editing from the BKMA-505. 0 .. <u>5</u> .. 15 seconds
002 * BI	CHARACTER H-POSITION	Set the horizontal position of timecode and other superimposed text information output from the MONITOR OUT terminals of the SDI (SUPER) and ANALOG COMPOSITE (SUPER) terminals. The value 00 .. <u>16</u> .. 31:00 corresponds to the distance from the left edge of the screen: incrementing the value by one moves the displayed text one character position to the right.
003 * BI	CHARACTER V-POSITION	Set the vertical position of timecode and other superimposed text information output from the MONITOR OUT terminals of the SDI (SUPER) and ANALOG COMPOSITE (SUPER) terminals. The value 00 .. <u>10</u> .. 12:00 corresponds to the distance from the top edge of the screen: incrementing the value by one moves the displayed text down one line.
005 BI	DISPLAY INFORMATION SELECT	Select the information superimposed on the output from the SDI (SUPER) and ANALOG COMPOSITE (SUPER) connectors when the CHARACTER switch on the system setup panel is set to ON. <u>time &amp; stat</u> : Time data information and operating status <u>time &amp; UB</u> : Time data information and user bits <u>time only</u> : Time data only <u>time &amp; TM1</u> : Time data information and TM1 <u>time &amp; TM2</u> : Time data information and TM2
006 BI	LOCAL FUNCTION ENABLE	Select which buttons on the control panel of this unit can be operated when being remotely controlled by another device. <u>all disable</u> : All buttons and switches are disabled. <u>stop</u> : Only the STOP button operates. <u>all enable</u> : All controls operate.
007 BI	POSTROLL TIME	This item sets the post-roll time when performing editing from the BKMA-505. 0 .. <u>5</u> .. 15 seconds
008 BI	ANALOG MONITOR SUPERIMPOSE	Sets the control method for superimpose data output for MONITOR OUT of ANALOG COMPOSITE. <u>switch</u> : Switches the CHARACTER SW on/off. <u>inhibit</u> : Normally not output.
009 * BI	CHARACTER TYPE	Select the character style of the information superimposed on the output from the SDI (SUPER) and ANALOG COMPOSITE (SUPER) connectors. <u>white</u> : White characters on black background <u>black</u> : Black characters on white background <u>W/out</u> : White characters with black outline <u>B/out</u> : Black characters with white outline
010	- 525/625 SUB MENU EXECUTE 525/625	Select the NTSC or PAL standard. <u>525/60</u> : NTSC <u>625/50</u> : PAL <b>Note:</b> After changing the settings for this item, all material must be erased using - ALL ERASE (menu 099).
011 * BI	CHARACTER V-SIZE	Set the height of timecode and other information superimposed on the output from the SDI (SUPER) and ANALOG COMPOSITE (SUPER) connectors. <u>X1</u> : Normal <u>X2</u> : Double height
012	DROP FRAME MODE (WITH 525 OPERATION ONLY)	Select the timecode generator operating mode. <u>DF</u> : Drop-frame mode <u>NDF</u> : Non-drop-frame mode <b>Note:</b> After changing the settings for this item, all material must be erased using - ALL ERASE (menu 099).

\* When setting items 002, 003, 009 and 011, watch the monitor to obtain the desired condition. (However, if the setting differs from the currently running SETUP BANK, the location of the character data on the monitor will not change.

Basic menu items (Continued)

Item number	Display indication	Settings
013 014 015	PB/EE SELECT P1 PB/EE SELECT P2 PB/EE SELECT P3  BI	For the PANEL, DTR+PANEL, DTR+DTR and BVE modes, specifies when the PB port enters the state indicated by SETUP MENU 108 AUTO EE SELECT, and whether it should automatically correspond to the REC port. <b>PB</b> : Always output at the PB side. PB/EE : Switch to the REC side according to the SETUP MENU 108 status. <b>Note:</b> In the BVE mode, "PB/EE SELECT P2" item (menu 014) is disabled.
016	CHARACTER POSITION V SHIFT  BI	The vertical position of text display of time codes output from the MONITOR OUT terminal, SDI (SUPER) and ANALOG COMPOSITE (SUPER) terminals, can be more minutely adjusted than is possible with SETUP MENU 003. <b>0</b> .. 20
019	SYSTEM OPERATE CONFIGURATION	Select the application mode for this unit. <b>PANEL</b> : All ports are controlled only from the optional BKMA-505 DTR + PANEL : Controls R1 and P1 with the DTR-3000, controls R2 and P2 (or P2 and P3) from the BKMA-505. DTR + DTR : The R1/P1 and R2/P2 pairs are controlled by two DTR-3000 units. BVE : R1 and P1 are controlled as an RP port by the editor.
022	ERROR INFORMATION SELECT  BI	Activate or deactivate various status information display output from the MONITOR OUT connectors of the SDI (SUPER) or ANALOG COMPOSITE (SUPER) connectors. <b>Note:</b> This setting item takes priority over the system setup panel CHARACTER switch setting.
	SUB MENU	
	ERROR/WARNING	Specifies whether the ERROR/WARNING display is on or off. <b>on</b> off <b>Note:</b> Even if this is set to "on", the warning message "Ref. Missing" is not displayed.
	NOT ENOUGH SPACE	Specifies whether a warning message is displayed when there remains approximately five minutes of recording time on the HDD. <b>on</b> off
027	- FAST REBOOT	Carry out a fast reboot of the system. This is faster than switching the system off and on again, because the HDD power supply is not turned off. Start : Start reboot.
	SUB MENU	
	EXECUTE	
028	AUDIO BIT LENGTH	Select the word length for audio sampling. 16 bits <b>20 bits</b> <b>Notes:</b> <ul style="list-style-type: none"> <li>• Bit length cannot be set for individual lots of material.</li> <li>• After changing the settings for this item, all material must be erased using -ALL ERASE (menu 099).</li> </ul>
030	GOOD SHOT PARAMETER  BI	Specifies the partial save method to use for Replay scenes with the DTR-3000, for highlight editing with DTR+Panel and DTR+DTR modes.
	SUB MENU	
	SAVE DUR. (1 .. <b>5</b> .. 255)	Specifies the partial save duration, in seconds.
	TRIM SIZE (0 .. <b>5</b> .. 15)	Specifies the trim length to be added before and after the partial save period.
	AUTO SAVE	Specifies the trigger command to start partial saving. <b>off</b> : Partial save disabled cue up with data : Start partial save after cue up.
	CUEUP SELECT	Specifies the time data at which to perform cue up in DTR+PANEL or DTR+DTR mode. <b>FTC</b> : Regardless of the timer mode, cue up is performed with TM2 (FTC). timer mode : Cue up is performed according to the timer mode. <b>Notes:</b> <ul style="list-style-type: none"> <li>• When using the DISK INDIVIDUAL MODE of the DTR-3000, select "FTC". However, select "timer mode" in the following cases: <ul style="list-style-type: none"> <li>- When performing direct cue up in 205 point mode from the keypad.</li> <li>- When performing cue up in 10 point mode with SERACH + CUEn.</li> </ul> </li> <li>• When using a controller other than the DTR-3000, select "timer mode". In this situation it is not possible to use the GOOD SHOT function, so set the AUTO SAVE item (menu 030) to "off".</li> </ul>

Basic menu items (Continued)

Item number	Display indication	Settings																				
030	DTR CUE LIST CLEAR B	Selects whether to delete the DTR-3000 cue list when files are unloaded. enable : The cue list is deleted. disable : The cue list is not deleted.																				
034	LIVE DURATION B SUB MENU DTR-1 HOUR (0 .. 1 .. 23) DTR-1 MIN (0 .. 59) DTR-2 HOUR (0 .. 1 .. 23) DTR-2 MIN (0 .. 59)	In the DTR + Panel or DTR + DTR mode, specify the length reserved for recording. DTR-1 settings apply to the R1/P1 pair, and DTR-2 settings apply to the R2/P2 pair. <b>Notes:</b> This is affected by the VIDEO COMPRESSION RATE and HDD capacity. Confirm the available disk space (SysRemain page 2-3), and follow the notes below on setting. Maximum recording times are shown in the following table. <table border="1" data-bbox="727 476 1410 661"> <thead> <tr> <th>Input/output signal</th> <th colspan="2">30 Mbps</th> <th>40 Mbps</th> <th>50 Mbps</th> </tr> <tr> <th>Audio</th> <th>16-bit</th> <th>20-bit</th> <th>20-bit</th> <th>20-bit</th> </tr> </thead> <tbody> <tr> <td>SS mode</td> <td>6 h 20 min</td> <td>5 h 20 min</td> <td>4 h 50 min</td> <td>3 h 40 min</td> </tr> <tr> <td>SD mode</td> <td>19 h 20 min</td> <td>16 h</td> <td>14 h 40 min</td> <td>11 h 20 min</td> </tr> </tbody> </table> <ul style="list-style-type: none"> <li>• After changing LIVE DURATION, the material must be erased. Delete the material named “LIVE1” (and “LIVE2”) in the Panel mode and reboot with DTR+Panel (or DTR+DTR) mode, or reboot after deleting all materials.</li> <li>• In DTR+Panel mode, the time specified by this menu must not exceed SysRemain.</li> <li>• In DTR+DTR mode, the time specified for DTR-1 plus the time specified for DTR-2 in this menu item must not exceed the SysRemain time minus 3 minutes.</li> <li>• If an incorrect setting is specified, the warning message “DM1 File Open Fail” or “DM2 File Open Fail” appears on the front panel after rebooting. In this case, make the correct setting, then reboot the unit.</li> <li>• To record from the beginning of the disk, recorded material must first be erased. In the Panel mode, delete the material named “LIVE1” (and “LIVE2”) in and reboot to DTR+Panel (or DTR+DTR) mode, or reboot after deleting all materials by executing -ALL ERASE (menu 099).</li> </ul>	Input/output signal	30 Mbps		40 Mbps	50 Mbps	Audio	16-bit	20-bit	20-bit	20-bit	SS mode	6 h 20 min	5 h 20 min	4 h 50 min	3 h 40 min	SD mode	19 h 20 min	16 h	14 h 40 min	11 h 20 min
Input/output signal	30 Mbps		40 Mbps	50 Mbps																		
Audio	16-bit	20-bit	20-bit	20-bit																		
SS mode	6 h 20 min	5 h 20 min	4 h 50 min	3 h 40 min																		
SD mode	19 h 20 min	16 h	14 h 40 min	11 h 20 min																		
	DTR-1 LOOP REC DTR-2 LOOP REC	Specifies whether to record in a loop within the allocated space. off : Record normally on : Record in a loop. When recording reaches the end of the allocated space, recording returns to the beginning of the space and continues.																				
035	VIDEO COMP. RATE	This item sets the default value for the recording video rate. (Note that this value is always used for ports that are used by the DTR in DTR-panel mode or DTR-DTR mode.) 30M bps 40M bps 50M bps																				
042	PORT CONFIGURATION	Specifies port configurations for input and output. 1 in 1 out Super Slow :SS mode 2 in 2 out :SD mode 3 in 1 out :SD mode 1 in 3 out																				

### Basic menu items (Continued)

Item number	Display indication	Settings	
050 051 052	LINE SUPERIMPOSE P1 LINE SUPERIMPOSE P2 LINE SUPERIMPOSE P3	Set the time code and other superimposed text information to be output from the analog composite B terminal of ports P1, P2 and P3.	
BI	SUB MENU		
	SUPERIMPOSE		off : No superimposed text information is displayed. on : Superimposed text information is displayed.
	DISPLAY INFORMATION		Sets the superimposed text information contents time data & status : Time data and operational status time data & UB : Time data and user bits time data & time data time data & TM1 : Time data and TM1 time data & TM2 : Time data and TM2 time data only time data & file name
	CHARACTER TYPE		Sets the character type for superimposed text information. white : White characters on black background black : Black characters on white background White out : White characters with black outlines Black out : Black characters with white outlines
	CHARACTER H POSITION		Sets the horizontal position of the superimposed text information. 0 .. 20 .. 37 : Setting 0 displays from the left edge of the screen, with each increment moving the displayed text to the right one character.
	CHARACTER V POSITION		Sets the vertical position of the superimposed text information. 0 .. 86 .. 107 : Setting 0 displays from the top edge of the screen, with each increment moving the displayed text down one line.
	CHARACTER V SIZE		Select the vertical size of the superimposed text information. 1 .. 2
097	FACTORY PRESET	Restores all items on the SETUP MENU to their default settings set at the factory before shipping. Start : Restores SETUP MENU defaults. <b>Note:</b> The new settings are not shown until you have executed FACTORY PRESET and cycled the system off and on.	
	SUB MENU		
	EXECUTE		
098	- NEW HDD	Rebuilds a replacement HDD. Carry this out once after replacing a HDD. Start : Start setup and rebuild operation begin.	
I	SUB MENU		
	EXECUTE		
099	- ALL ERASE	Erase all material saved on the HDD. Start : Erases all material	
I	SUB MENU		
	EXECUTE		



## 3-4-2 Basic Menu Operation

To change the factory default settings, proceed as follows.

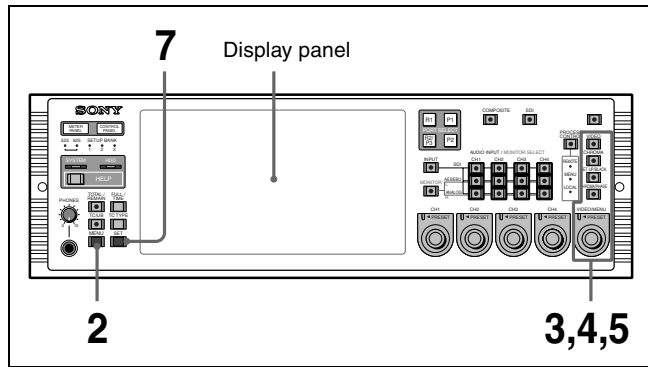

- 1 Set the SET UP SELECT switch on the system setup panel to the desired menu bank.

### Note

When the menu bank is modified after power up, the MAV-555SS must be restarted or the FAST REBOOT (menu 027) on the Basic menu must be executed. (Changes in settings made while the power is off do not become effective the next time the power is turned on. It is necessary to start up the system a second time.)

- 2 Press the MENU button. A menu item appears in the time counter display in the display panel.

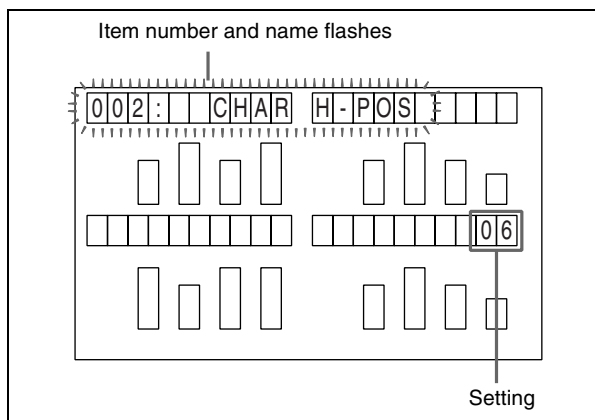

- 3 Turn the MENU control to select the item you want to change. Turning the MENU control clockwise increases the item number, and turning it counterclockwise decreases the item number.
- 4 Press the MENU control once. This allows the setting to be changed, and the setting value flashes.

Turn the MENU control to change the setting.

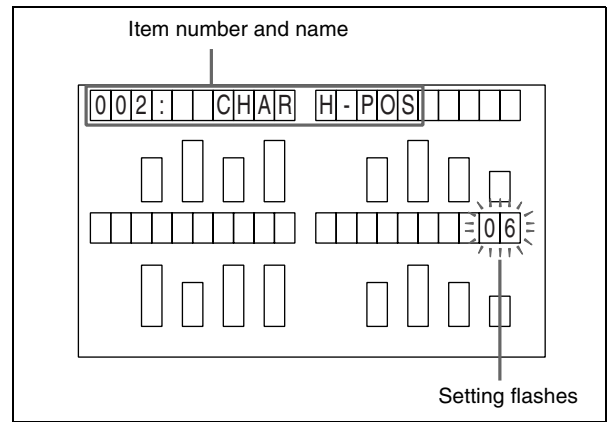

- 5 When the desired setting appears, press the MENU control once more. This confirms the setting, and the menu item number and name starts flashing again. *To change settings in a menu item including a submenu, see the section, "Menu items with submenus".*
- 6 To make other menu settings, repeat steps 3 to 5.
- 7 When the settings are complete, press the SET button. This saves the settings, and the display returns to showing a time value.

### To cancel setting changes

In step 7 above, before pressing the SET button, press the MENU button. This exits the menu mode, without saving the settings.

### To change the menu display group by group

To change the menu display group by group, press the CHROMA button (it is not necessary to hold down the button).

In this state, turning the MENU control moves from one menu group to the next. To return to the MAIN MENU display, press the CHROMA button once more, or click the MENU control.

### Modes of operating the MENU control

It is possible to select either of two modes in which the MENU control operates when selecting items or changing settings: either the value changes only when you turn the control, or the value continues changing even when you stop turning.

Normally, the state is such that when you use the MENU control to select items or change settings, the value changes only when you turn the MENU control (the value stops changing when you stop turning).

However, if you press the SETUP/BLACK button, turning on the PRESET indicator above and to the left of the MENU control, the menu item or setting continues changing even when you stop turning.

To stop the change when the PRESET indicator is lit, do any of the following:

- Return the control to the center position
- Press the MENU control once
- Press the SETUP/BLACK button once more, turning the PRESET indicator off

### Menu items with submenus

The procedure for making settings in a menu including a submenu is slightly different from that described above in Section 3-4-2, “Basic Menu Operation”.

### Menus including a setting submenu

This type of menu item has a number of parameters to be set within a single menu item.

Use the following procedure in this type of menu.

- 1 Carry out steps 1 to 3 of the procedure at the beginning of this Section 3-4-2, “Basic Menu Operation”, and select a menu item. The following example shows menu item 034.
- 2 Press the MENU control once. This calls the submenu, and the display appears as follows.

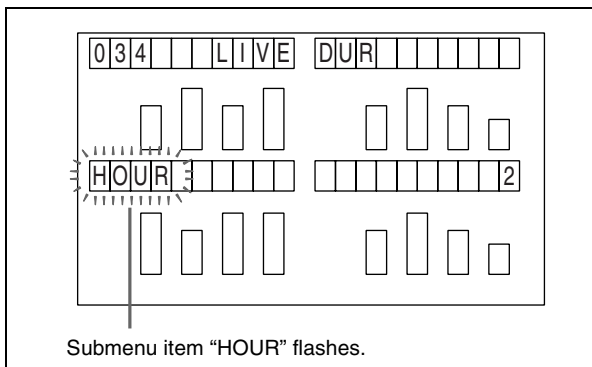

- 3 Turn the MENU control to select the submenu item (HOUR/MIN). Select the submenu item you want to change.
- 4 Press the MENU control once more. The menu item stops flashing, and in its place the setting value starts flashing.
- 5 Turn the MENU control to change the setting value.
- 6 Here, to return to the submenu item selection, press the VIDEO button. The submenu item starts flashing again.
- 7 Repeat steps 3 to 6 above as required.
- 8 After all of the necessary submenu items have been set, press the MENU control. This returns to the main menu (with the menu item on the top line flashing).

- 9 To save the changed settings, press the SET button. This saves the settings, and the display returns to showing a time value.

### Menu containing executable submenus

Executable submenus perform operations such as formatting replacement HDDs. Names of these menu items are preceded by a hyphen, “-”.

Use the following procedure with this type of menu item. See the next page for the procedure to use with menu number 010.

- 1 Carry out steps 1 to 3 of the procedure at the beginning of this Section 3-4-2, “Basic Menu Operation”, and select menu item 098, 099, or 027. The following example shows menu item 027.
- 2 Press the MENU control once. This calls the submenu, and the display appears as follows.

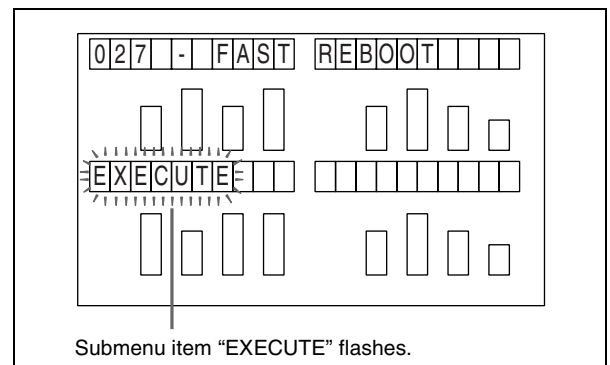

- 3 Press the MENU control once more. The “EXECUTE” stops flashing, and in its place the “NO?” starts flashing.
- 4 Turn the MENU control to display “YES → [SET]”

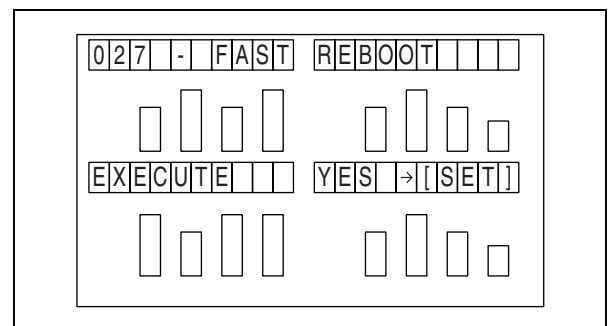

When you have changed the indication to “1: START,” a YES/NO confirmation screen appears for the physical formatting operation.

- 5 To start reformatting, press the SET button while the display shows “YES → [SET]”. To cancel the operation, select “NO?” and press the MENU knob or the MENU button.

For menu number 010 - 525/625, make settings as follows.

- 1** Carry out steps 1 to 3 of the procedure at the beginning of this Section 3-4-2, “Basic Menu Operation”, and select menu item 010.
- 2** Press the MENU knob once.
- 3** Turn the MENU knob to the right, and the display appears as follows.

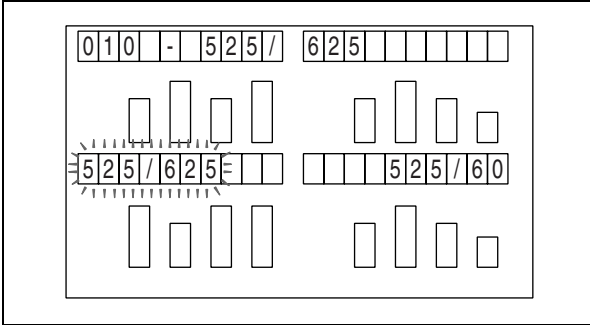

- 4** Press the MENU knob.

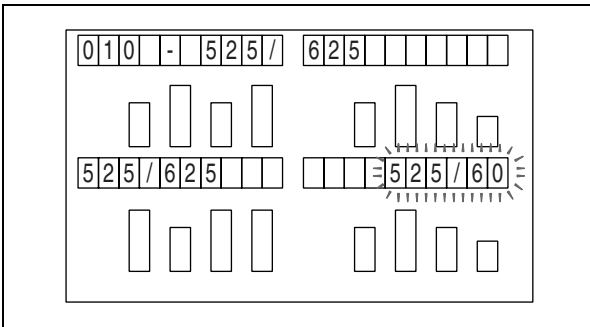

- 5** Turn the MENU knob and make the desired settings.
- 6** Press the VIDEO button.  
You will return to the screen in step 3.
- 7** Turn the MENU knob, and the display appears as follows.

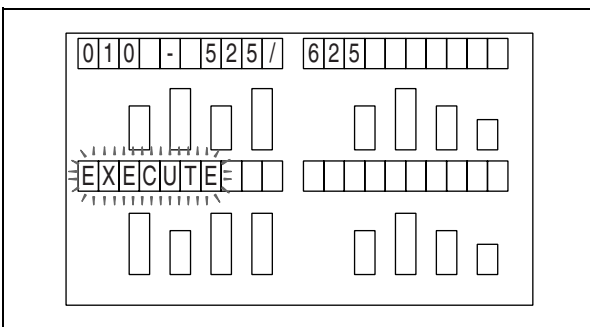

- 8** Press the MENU knob.

“EXECUTE” stops flashing, and “NO?” starts flashing instead.

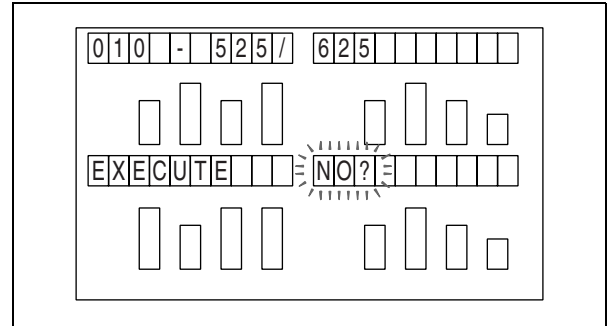

- 9** When changing settings, turn the MENU knob to display “YES → [SET]”, then press the SET button. To cancel the operation, select “NO” and turn the MENU knob or press the MENU button.

### 3-4-3 Contents of the Expansion Menu

The contents of the Expansion menu are described in the table that follows.

- The item enclosed in a square in the “Settings” column indicates defaults.
- The letters “B” and “I” in the item number column indicate when a change to that setting becomes effective, just as in the Basic menu.

For details on the meaning of each letter, refer to Section 3-4-1, “Basic Menu Settings” (page 3-18).

Expansion menu items

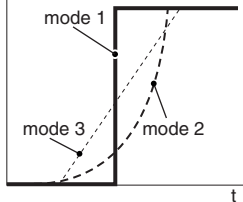
Item number	Display indication	Settings	Description
101	BI	SELECTION FOR SEARCH DIAL ENABLE	This item sets the method for putting the MAV-555SS into search mode. dial direct : The unit enters search mode when the search dial is turned from any mode except while recording/editing are in progress. via search key : The unit enters search mode when any of the following buttons is pressed: JOG, SHUTTLE, VAR.
102	BI	SHUTTLE MODE SYNCHRONIZE	This item specifies the startup characteristics when entering shuttle mode. mode 1 : Normal disk characteristics mode 2 : Squared acceleration mode 3 : Linear acceleration
			
105	B	SYNCHRONIZE	This item specifies, for playback and for variable speed playback (JOG/VAR) with FORT synchronization control, whether to apply speed limitations when reversing the playback direction or to not apply speed limitations and give priority to response. off : Apply no speed limitations, and give priority to response. on : Apply speed limitation. <b>Note:</b> When playing back material recorded in SS mode, this setting reverts to off.
106	BI	MAXIMUM SHUTTLE SPEED	This item specifies the maximum shuttle speed. ×8 : Maximum shuttle speed is 8×. ×16 : Maximum shuttle speed is 16×. ×32 : Maximum shuttle speed is 32×. ×50 : Maximum shuttle speed is 50×. ×100 : Maximum shuttle speed is 100×. ×200 : Maximum shuttle speed is 200×. ×500 : Maximum shuttle speed is 500×. <b>Note:</b> With some editing equipment, if a maximum speed of 100× or greater is set, the speed is deemed to be impossible for FF or REW, and the TC display disappears. If using equipment in which this happens, set a speed of less than 100×.
107	BI	MAXIMUM JOG SPEED	Sets the maximum JOG speed. ×1, ×2, ×4, SHUTTLE When SHUTTLE is selected, the maximum speed set in SETUP MENU 106 is applied. <b>Note:</b> This means that synchronization is not possible during linear editing when the JOG speed is set to ×2 (or greater). For linear editing, set the JOG speed to ×1.
108	BI	AUTO EE SELECT	This item sets the conditions for switching to the REC port when PB/EF SELECT (menu 013) is set to PB/EE. stop/f.fwd/rew : Switch the PB side to the EE side during STOP/FAST FORWARD/REWIND. stop : Switch the PB side to the EE side during STOP.
109	BI	ENFORCED EE INTERFACE	Enables the ENFORCED function of the EE command specified from the 9PIN terminal and meter panel in the Panel mode. This menu setting and the control panel setting match and determine the ENFORCED EE function from the control panel. enable : Enables ENFORCED EE disable : Ignores the command.
120	I	OUTPUT REF LOCK	This item specifies whether to synchronize the output system video refresh with the REF input jack, the R1 video input jack, or the R2 video input jack. REF : Synchronize with the reference video signal input through the REF IN jack. R1 : Synchronize with the video signal input through R1. R2 : Synchronize with the video signal input through R2. <b>Note:</b> When the configuration is 3 input/1 output, the R3 port cannot be specified.

### Expansion menu items (Continued)

Item number	Display indication	Settings	Description	
140* <sup>1</sup>	LOAD SETUP ALL		Loads Setup menu settings of all banks (bank 1 to bank 3) from a memory card. <b>Note:</b> Loaded settings are not effective until you restart.	
	SUB MENU			
	EXECUTE	Start	: Loads Setup menu settings. <b>Note:</b> Cannot be executed unless all bank data is saved on a memory card.	
141* <sup>1</sup>	SAVE SETUP ALL		Saves the Setup menu settings of all banks (bank 1 to bank 3) on a memory card. <b>Notes:</b> <ul style="list-style-type: none"> <li>• Overwrites bank data previously saved on the memory card.</li> <li>• When you use a memory card for the first time with the MAV-555SS, it takes ten to twenty seconds to save the data.</li> </ul>	
	SUB MENU			
	EXECUTE	Start	: Saves Setup menu settings.	
142* <sup>1</sup>	LOAD SETUP BANK		Loads Setup menu settings of a specific bank from a specified bank on the memory card. <b>Note:</b> Loaded settings are not effective until you restart.	
	SUB MENU			
	EXECUTE	Start	: Loads Setup menu settings. <b>Note:</b> Cannot be executed unless bank data is saved on a memory card.	
	SETUP BANK		Specifies the bank where data is loaded. [BANK1] BANK2 BANK3	
	CARD BANK		Specifies a bank on the PC card. [1] .. 10	
143* <sup>1</sup>	SAVE SETUP BANK		Saves the Setup menu settings of a specified bank in a specified bank on the memory card. <b>Notes:</b> <ul style="list-style-type: none"> <li>• Overwrites bank data previously saved on the memory card.</li> <li>• When you use a memory card for the first time with the MAV-555SS, it takes ten to twenty seconds to save the data.</li> </ul>	
	SUB MENU			
	EXECUTE	Start	: Saves Setup menu settings. <b>Note:</b> SETUP MENU settings cannot be saved unless a memory card is inserted in the PCMCIA card slot.	
	SETUP BANK		Specifies the bank where data is saved. [BANK1] BANK2 BANK3	
	CARD BANK		Specifies a bank on the memory card. [1] .. 10	
200	9PIN CONNECTOR		Sets the SONY 9PIN protocol connector on the rear panel.	
	SUB MENU			
	SPARE		Sets the SPARE terminal. [F-555] : Connects the MAVE-F555. DFSCP : Connects any control panel.	
220	IP ADDRESS		This item specifies the Ethernet* <sup>2</sup> interface IP address.	
	SUB MENU			
	BYTE1			0 .. [192] .. 255
	BYTE2			0 .. [168] .. 255
	BYTE3			[0] .. 255
	BYTE4			0 .. [1] .. 255
221	SUBNET MASK		This item specifies the Ethernet* <sup>2</sup> interface subnet mask.	
	SUB MENU			
	BYTE1			0 .. [225]
	BYTE2			
	BYTE3			
	BYTE4			[0] .. 255

\*1 Data recorded with the MAV-555/555A is incompatible with the MAV-555SS, and vice-versa.

\*2 "Ethernet" is a registered trademark of the Xerox Corporation.

Expansion menu items (Continued)

Item number	Display indication	Settings	Description																																									
222	DEFAULT GATEWAY		This item specifies the Ethernet* interface default gateway.																																									
	SUB MENU																																											
	BYTE1	0 .. 255																																										
	BYTE2																																											
	BYTE3																																											
223	BI	GPI INPUT CONFIGURATION	When GPI CONFIG MODE (menu 225) is "CONFIG," this item specifies the function for the GPI pins.																																									
		SUB MENU																																										
		PIN 1 .. 8 PORT PIN 18 .. 25 PORT PIN 34 .. 41 PORT	<p>This item specifies the effect of the set function on each port input pin.</p> <ul style="list-style-type: none"> <li>When the function is not FILE+, FILE-, RECED <table border="1"> <thead> <tr> <th>Setting</th> <th>1 input/3 output</th> <th>2 input/2 output</th> <th>3 input/1 output</th> <th>1 input/1 output (SS mode)</th> </tr> </thead> <tbody> <tr> <td>1</td> <td>R1</td> <td>R1</td> <td>R1</td> <td>R1</td> </tr> <tr> <td>2</td> <td>P1</td> <td>P1</td> <td>P1</td> <td>P1</td> </tr> <tr> <td>3</td> <td>P2</td> <td>R2</td> <td>R2</td> <td rowspan="2">Invalid</td> </tr> <tr> <td>4</td> <td>P3</td> <td>P2</td> <td>R3</td> </tr> </tbody> </table> </li> <li>When the function is FILE+, FILE-, RECED <table border="1"> <thead> <tr> <th>Setting</th> <th>1 input/3 output</th> <th>2 input/2 output</th> <th>3 input/1 output</th> <th>1 input/1 output (SS mode)</th> </tr> </thead> <tbody> <tr> <td>1</td> <td colspan="3">RP(BVE mode) P1(Panel mode)</td> <td>P1 (Panel mode)</td> </tr> <tr> <td>2</td> <td>P2</td> <td>P2</td> <td>Invalid</td> <td rowspan="2">Invalid</td> </tr> <tr> <td>3</td> <td colspan="3">R2</td> </tr> </tbody> </table> </li> </ul>	Setting	1 input/3 output	2 input/2 output	3 input/1 output	1 input/1 output (SS mode)	1	R1	R1	R1	R1	2	P1	P1	P1	P1	3	P2	R2	R2	Invalid	4	P3	P2	R3	Setting	1 input/3 output	2 input/2 output	3 input/1 output	1 input/1 output (SS mode)	1	RP(BVE mode) P1(Panel mode)			P1 (Panel mode)	2	P2	P2	Invalid	Invalid	3	R2
Setting	1 input/3 output	2 input/2 output	3 input/1 output	1 input/1 output (SS mode)																																								
1	R1	R1	R1	R1																																								
2	P1	P1	P1	P1																																								
3	P2	R2	R2	Invalid																																								
4	P3	P2	R3																																									
Setting	1 input/3 output	2 input/2 output	3 input/1 output	1 input/1 output (SS mode)																																								
1	RP(BVE mode) P1(Panel mode)			P1 (Panel mode)																																								
2	P2	P2	Invalid	Invalid																																								
3	R2																																											
PIN 1 .. 8 FUNCTION PIN 18 .. 25 FUNCTION PIN 34 .. 41 FUNCTION	<p>This item specifies the function of the GPI input pins. Also, when GPI CONFIG MODE (menu 225) is "CONFIG," this item specifies the function for the GPI input pins.</p> <p> <b>NOF</b> : No operation.  <b>STOP</b> : Executes the STOP command.  <b>PLAY</b> : Executes the PLAY command.  <b>REC</b> : Executes the REC command.  <b>FF</b> : Executes the Fast Forward command.  <b>REW</b> : Executes the Rewind command.  <b>TOP</b> : Executes the CueUp SOF command.  <b>END</b> : Executes the CueUP EOF command.  <b>STP+1</b> : Executes the STEP+1 command.  <b>STP-1</b> : Executes the STEP-1 command.  <b>ST+10</b> : Executes the STEP+10 command.  <b>ST-10</b> : Executes the STEP-10 command.  <b>ULOAD</b> : Executes the UNLOAD command.  <b>REMOT</b> : Executes REMOTE (for REMOTE/LOCAL).  <b>LOCAL</b> : Executes LOCAL (for REMOTE/LOCAL).  <b>REC1F</b> : Executes 1-frame recording.  <b>SOFPL</b> : After executing the CueUp SOF command, executes the PLAY command.  <b>FILE+</b> : Executes file switch in the + direction.  <b>FILE-</b> : Executes file switch in the - direction.  <b>FILE+/FILE-</b> can be used with <ul style="list-style-type: none"> <li>The playback port in the PANEL mode</li> <li>Port P2 in the DTR+PANEL mode</li> <li>The playback port in the BVE mode.</li> </ul> <b>RECED</b> : Stops on the R2 port, switches files. (BVE mode)  <b>TOPFL</b> : Switches to the beginning of the file list. </p>																																											

\* "Ethernet" is a registered trademark of the Xerox Corporation.

**Expansion menu items (Continued)**

Item number	Display indication	Settings	Description																								
224	GPI OUTPUT CONFIGURATION		When GPI CONFIG MODE (menu 225) is "CONFIG," this item specifies the function for the GPI pins.																								
	SUB MENU																										
	PIN 9 .. 16 PORT PIN 26 .. 33 PORT PIN 42 .. 49 PORT		This item specifies the effect of the set function on each port output pin.																								
		<table border="1"> <thead> <tr> <th>Setting</th> <th>1 input/3 output</th> <th>2 input/2 output</th> <th>3 input/1 output</th> <th>1 input/1 output (SS mode)</th> </tr> </thead> <tbody> <tr> <td>1</td> <td>R1</td> <td>R1</td> <td>R1</td> <td>R1</td> </tr> <tr> <td>2</td> <td>P1</td> <td>P1</td> <td>P1</td> <td>P1</td> </tr> <tr> <td>3</td> <td>P2</td> <td>R2</td> <td>R2</td> <td rowspan="2">Invalid</td> </tr> <tr> <td>4</td> <td>P3</td> <td>P2</td> <td>R3</td> </tr> </tbody> </table>	Setting	1 input/3 output	2 input/2 output	3 input/1 output	1 input/1 output (SS mode)	1	R1	R1	R1	R1	2	P1	P1	P1	P1	3	P2	R2	R2	Invalid	4	P3	P2	R3	
Setting	1 input/3 output	2 input/2 output	3 input/1 output	1 input/1 output (SS mode)																							
1	R1	R1	R1	R1																							
2	P1	P1	P1	P1																							
3	P2	R2	R2	Invalid																							
4	P3	P2	R3																								
	PIN 9 .. 16 FUNCTION PIN 26 .. 33 FUNCTION PIN 42 .. 49 FUNCTION		<p>This item sets the function of the GPI output pins.</p> <p><b>NOP</b> : No operation.</p> <p><b>LOCAL</b> : Indicates the LOCAL status.</p> <p><b>REF</b> : Indicates ALARM-REFERENCE.</p> <p><b>COMPL</b> : Indicates port command was completed.</p> <p><b>INPRO</b> : Indicates port command is in progress.</p> <p><b>TOP</b> : At File Top.</p> <p><b>END</b> : At File End.</p> <p><b>MPLAY</b> : File was opened in Open Play mode.</p> <p><b>MREC</b> : File was opened in Open Rec mode.</p> <p><b>MNEXT</b> : File was opened in Open Next mode.</p> <p><b>MEDIT</b> : File was opened in Open Edit mode. (DTR mode only)</p> <p><b>STBON</b> : STANDBY ON state.</p> <p><b>STOP</b> : STOP state.</p> <p><b>REW</b> : REWIND state.</p> <p><b>FF</b> : FAST FORWARD state.</p> <p><b>REC</b> : REC state.</p> <p><b>PLAY</b> : PLAY state.</p> <p><b>SHUTL</b> : SHUTTLE state.</p> <p><b>JOG</b> : JOG state.</p> <p><b>VAR</b> : VARIABLE state.</p> <p><b>RV/FW</b> : Indicates the playback direction.(displays ON for REV playback)</p> <p><b>STILL</b> : STILL state.</p> <p><b>CUECP</b> : Cue Up was completed.</p> <p><b>SELEE</b> : Selected EE state.</p> <p><b>FULEE</b> : Full EE state.</p> <p><b>EDIT</b> : Edit state. (BVE mode only)</p> <p><b>CUPRE</b> : Either Cue Up or Preroll state. (BVE mode only)</p> <p><b>INSPR</b> : Insert Preset enabled. (BVE mode only)</p> <p><b>ASMPR</b> : Assemble Preset enabled. (BVE mode only)</p> <p><b>VPRST</b> : Video Preset enabled. (BVE mode only)</p> <p><b>DA1</b> : Digital Audio 1 is preset. (BVE mode only)</p> <p><b>DA2</b> : Digital Audio 2 is preset. (BVE mode only)</p> <p><b>DA3</b> : Digital Audio 3 is preset. (BVE mode only)</p> <p><b>DA4</b> : Digital Audio 4 is preset. (BVE mode only)</p> <p><b>RECIH</b> : Rec Inhibit enabled.</p> <p><b>WPROT</b> : Write Protect enabled.</p> <p><b>ENDLS</b> : Endless Mode.</p> <p><b>EP1</b> : Indicates the passage of this IN point. (Only for IN points specified with the MAVE-F555 in BVE mode.)*1</p> <p><b>READY</b> : Port Not Ready state. (DTR mode only)</p> <p><b>EP2</b> : Indicates the passage of this IN point. (Only for IN points specified with the MAVE-F555 in BVE mode.)*1</p> <p><b>TEVWR</b> : Displays the warning using the time difference forward function.</p> <p><b>TEVER</b> : Displays the error using the time difference forward function.</p> <p><b>STOP2</b> : Either Stopped or UNLOAD state.</p> <p>*1 Offset control is submitted to MAVE-F555 CONTROL (menu 320). Further, port settings are unnecessary.</p>																								

Expansion menu items (Continued)

Item number	Display indication	Settings Description																																																						
225	GPI CONFIG MODE	Setting determines whether the GPI I/O PIN is a fixed function or can be set.																																																						
	BI SUB MENU																																																							
	GPI CONFIGURE MODE	Setting determines whether the GPI I/O PIN is a fixed function or can be set. If it can be set, the GPI INPUT CONFIGURATION (menu 223) and GPI INPUT CONFIGURATION (menu 224) settings are effective. <b>preset</b> : Used as a fixed function. <b>config</b> : Allows setting. When set as fixed function, the following functions are assigned.																																																						
		<table border="1"> <thead> <tr> <th>PIN</th> <th>I/O</th> <th>FF</th> </tr> </thead> <tbody> <tr><td>1</td><td>i</td><td>R1 Rec</td></tr> <tr><td>2</td><td>i</td><td>R1 Stop</td></tr> <tr><td>3</td><td>i</td><td>P1 Play</td></tr> <tr><td>4</td><td>i</td><td>P1 Stop</td></tr> <tr><td>5</td><td>i</td><td>R2 Rec</td></tr> <tr><td>6</td><td>i</td><td>R2 Stop</td></tr> <tr><td>7</td><td>i</td><td>R2 Rec Close (BVE mode only)</td></tr> <tr><td>8</td><td>i</td><td>P2 Play</td></tr> <tr><td>18</td><td>i</td><td>P2 Stop</td></tr> <tr><td>9</td><td>o</td><td>R1 REC Status</td></tr> <tr><td>10</td><td>o</td><td>R1 Stop Status</td></tr> <tr><td>11</td><td>o</td><td>P1 Play Status</td></tr> <tr><td>12</td><td>o</td><td>P1 Stop Status</td></tr> <tr><td>13</td><td>o</td><td>R2 Rec Status</td></tr> <tr><td>14</td><td>o</td><td>R2 Stop Status</td></tr> <tr><td>16</td><td>o</td><td>P2 Play Status</td></tr> <tr><td>26</td><td>o</td><td>P2 Stop Status</td></tr> </tbody> </table>	PIN	I/O	FF	1	i	R1 Rec	2	i	R1 Stop	3	i	P1 Play	4	i	P1 Stop	5	i	R2 Rec	6	i	R2 Stop	7	i	R2 Rec Close (BVE mode only)	8	i	P2 Play	18	i	P2 Stop	9	o	R1 REC Status	10	o	R1 Stop Status	11	o	P1 Play Status	12	o	P1 Stop Status	13	o	R2 Rec Status	14	o	R2 Stop Status	16	o	P2 Play Status	26	o	P2 Stop Status
	PIN	I/O	FF																																																					
1	i	R1 Rec																																																						
2	i	R1 Stop																																																						
3	i	P1 Play																																																						
4	i	P1 Stop																																																						
5	i	R2 Rec																																																						
6	i	R2 Stop																																																						
7	i	R2 Rec Close (BVE mode only)																																																						
8	i	P2 Play																																																						
18	i	P2 Stop																																																						
9	o	R1 REC Status																																																						
10	o	R1 Stop Status																																																						
11	o	P1 Play Status																																																						
12	o	P1 Stop Status																																																						
13	o	R2 Rec Status																																																						
14	o	R2 Stop Status																																																						
16	o	P2 Play Status																																																						
26	o	P2 Stop Status																																																						
	INPUT FUNCTION	Collects and halts GPI input functions. <b>enable</b> : GPI input terminals operate. <b>disable</b> : GPI input terminals do not operate.																																																						
	OUTPUT FUNCTION	Collects and halts GPI output functions. <b>enable</b> : GPI output terminals operate. <b>disable</b> : GPI output terminals do not operate.																																																						
299	BI RS422 INHIBIT on LOCAL MODE	When the LOCAL MODE is set with the REMOTE button on the front panel, makes the settings relative to the 9-pin connectors.																																																						
	BI SUB MENU																																																							
	BI DISK PROTOCOL	Specifies whether DISK PROTOCOL is accepted when the mode is set to LOCAL. <b>off</b> : Accepted in LOCAL MODE. <b>on</b> : Rejected in LOCAL MODE.																																																						
	BI PRESET COMMAND	Specifies whether the VTR Protocol 4x: Preset type command from the RS422 is effective and whether it is possible to switch between REMOTE and LOCAL with the RS422 when the mode is set to LOCAL. <b>on</b> : Ineffective in LOCAL MODE. <b>off</b> : Effective in LOCAL MODE.																																																						



Expansion menu items (Continued)

Item number	Display indication	Settings	Description
301	BI STANDARD COMPOSITE		This item selects either STD or NON-STD in accordance with the composite input signal. <input type="checkbox"/> auto : Automatically determines whether the luminance signal and color temperature signal in the input video signal are interleaved or not. Sets STD mode if they are interleaved, sets NON-STD mode if they are not interleaved. forced STD : Set this mode when STD mode is to be used at all times. forced non-STD : Set this mode if the color framing of the input video signal is unstable.
302 303 304	BI AUDIO FADE MODE P1 AUDIO FADE MODE P2 AUDIO FADE MODE P3		Specifies audio processing for the join between cuts produced by editing. <b>Note:</b> For editing from the control panel (BKMA-505), BVE mode editing is enabled only for the TIME setting, and the TYPE is set for close fade.
	SUBMENU		
	TYPE	X V <input type="checkbox"/> CUT	: Cross fade : V fade : No fade
	TIME	20 m sec <input type="checkbox"/> 1msec 2msec 4msec 5msec 6msec	
307	BI ANALOG AUDIO EDIT PRESET REPLACE		When editing digital audio on the MAV-555SS through a remote controller or an editor (such as the BVE-600) that does not have the functions that control the digital audio edit presets, this item sets the assignment of the channels to the editor's or remote controller's analog audio presets. This setting can be made for all digital audio channels.
	SUBMENU		
	CH 1 CH 2 CH 3 CH 4	nodef ch1 ch2 ch1+2	: No setting. : Follow the analog channel 1 edit presets. : Follow the analog channel 2 edit presets. : Follow either the analog channel 1 edit presets or the analog channel 2 edit presets. The default values for each channel are: CH1:ch1, CH2:ch2, CH3:nodef, and CH4:nodef.
317	B PANEL MODE RECORDER PORT		Sets the RECORDER port for editing from the BKMA-505 in the Panel mode. <input type="checkbox"/> R1P1 : Uses R1, P1 Port as the RECORDER port. The external device can be selected as the Player only on EXT1. R2P2 : Uses R2, P2 Port as the RECORDER port. The external device can be selected as the Player only on EXT2.
320	BI MAVE-F555 CONTROL		Sets control of MAVE-F555 when it is connected.
	SUB MENU		
	FILE CHANGE TIME		Sets the time to output an image after a key is released when using the +/- keys for file switching. 0s .. <input type="checkbox"/> 0.3s .. 0.9s
	DECISION BASE	<input type="checkbox"/> video audio	Sets the standard for A/V Split editing from the MAVE-F555. : Audio is split with Video as standard. : Video is split with Audio as standard.
	GPI EP1 TIME(F) GPI EP2 TIME(F)	-90 .. <input type="checkbox"/> 00 .. +90	Performs offset control for the IN point of the GPI output. (GPI OUTPUT CONFIGURATION item (menu 224)). <b>Notes:</b> <ul style="list-style-type: none"> <li>When the player is an external VTR or when performing DMC editing, the PREROLL TIME + GPI EPx TIME must be set so that it exceeds 2 seconds plus 2 frames.</li> <li>When trimming, the GPI EPx TIME must be set so that it exceeds -28 frames (in 525 mode. -23 frames in 625 mode). In other editing situations, PREROLL TIME + GPI EPx TIME must be set so that it exceeds 2 frames.</li> </ul>

Expansion menu items (Continued)

Item number	Display indication	Settings	Description
321	BI LINEAR EDIT NEW FILE LENGTH		Sets the BLACK/MUTING total file length in hours and minutes for the editing base in the BVE mode. <b>Note:</b> The BLACK/MUTING file is created with the New Material command on the BKMA-505 control panel, or by pressing the NEW FILE key on the editing panel of the MAVE-F555.
	SUB MENU		
	LENGTH HOUR	[0] .. 3	Sets hour units for total length.
	LENGTH MIN	0 .. [30] .. 59	Sets minute units for total length.
	SHOW TC HOUR		Specifies the New file Show point time code. The time code at the head of the file is set 15 sec. before the Show point time code. If no time code exists as with NTSC drop frames or PAL frames 25 to 29, then the nearest time code before the specified time code is used.
	SHOW TC MIN		
	SHOW TC SEC		
SHOW TC FRAME	HOUR : [00] .. 23 MIN : [00] .. 59 SEC : [00] .. 59 FRAME : [00] .. 29		
323	BI LINEAR EDIT MESSAGE		Sets the text information to be displayed in the BVE mode: current monitor port, file number, and file name.
	SUB MENU		
	V POSITION	0 .. [1] .. 11	Sets the vertical position of the text information (0 .. [1] .. 11)
	FADE TIME	Infinite : Always display. 1sec : Display for 1 second. 2sec : Display for 2 second. 3sec : Display for 3 second. [5sec] : Display for 5 second. 10sec : Display for 10 second. 15sec : Display for 15 second. 30sec : Display for 30 second. 1min : Display for 1 minute.	This item specifies how many seconds that changes in the display information will be displayed before automatically disappearing.
	TYPE	[norm] : Each type of information is displayed according to the operation. full : Detailed information is normally displayed. none : No information is displayed	Sets the text information display.
324	BI MAVE-F555 PORT		This item specifies the port that is assigned to the port selection keys ([P1], [P2]) in the F555 when the MAVE-F555 is connected to the MAV-555SS.
	SUB MENU		<i>For details, refer to section 3-4, "Recorder Selection Function," in the MAVE-F555 operation manual.</i>
	R SEL-VTR P1 KEY		This item assigns the port in the MAV-555SS that is selected by the [P1] and [P2] keys in the F555 when the [VTR] key in the F555 is selected. Further, the [R] key is set to VTR. none : No assignment to an MAV-555SS port. R1P1 : Assignment to the RP port in BVE mode. P2 : Assignment to the P2 port in BVE mode. [P2] , [R1P1]
	R SEL-VTR P2 KEY		
	R SEL-MAV P1 KEY		This item assigns the port in the MAV-555SS that is selected by the [R], [P1], and [P2] keys in the F555 when the [MAV] key in the F555 is selected. Further, the [R] key is set to R1P1. none : No assignment to an MAV-555SS port. R1P1 : Assignment to the RP port in BVE mode. P2 : Assignment to the P2 port in BVE mode. EXT : Assignment to an external VTR. [P2] , [none] It is also possible to assign different keys to the same ports. For details, refer to the MAVE-F555 Operation Manual.
	R SEL-MAV P2 KEY		
	BG PORT	[enable] : Operations such as REC or STOP on the R2 port, or LOAD, PLAY, STOP on the P3 port from the MAVE-F555 are permitted. disable : Operations such as REC or STOP on the R2 port, or LOAD, PLAY, STOP on the P3 port from the MAVE-F555 are prohibited.	Specifies whether the background port (R2/P3) is used.

Expansion menu items (Continued)

Item number	Display indication	Settings Description
325	BI MAVE-F555 EXT VTR CONTROL	Specifies edit parameters when an external VTR is selected as the Recorder in the BVE mode.
		SUB MENU
	EDIT DELAY	Specifies EDIT DELAY of the external VTR [0] .. 9 frame
	EDIT PRESET COMMEND	Specifies whether Audio Analog Channel 2 is used or Digital Audio Channel 4 is used in the EDIT PRESET command. [Digital] : Digital Audio Channel 4 is used. Analog : Analog Audio Channel 2 is used and Audio Channel 3 or 4 selections are ignored.
	UB BYTE 1 UB BYTE 2 UB BYTE 3 UB BYTE 4	Specifies the value of the user bit to specify the VTR during editing. [00] to FF
349 350 351	BI REFERENCE SELECT R1 REFERENCE SELECT R2 REFERENCE SELECT R3	Selects the reference signal for the recorder port. [output ref] : Selects the output signal as the reference. Input video : Selects the input signal as the reference. <b>Notes:</b> <ul style="list-style-type: none"> <li>• Changes in settings do not become effective until any file on the recorder port is unloaded.</li> <li>• In SS mode, set to output ref.</li> </ul>
352 353 354	BI REC INHIBIT R1 REC INHIBIT R2 REC INHIBIT R3	These items prohibit port recording. [REC INHIBIT off] : REC INHIBIT OFF (recording enabled) REC INHIBIT on : REC INHIBIT ON (recording prohibited)
401 402 403	BI FUNCTION MODE AFTER CUEUP P1 FUNCTION MODE AFTER CUEUP P2 FUNCTION MODE AFTER CUEUP P3	These items select the mode to be in effect for the MAV-555SS after the cue-up operation is completed. [stop] : Set stop mode. still : Set still mode (search mode).
404 405 406	BI VIDEO OUTPUT AFTER UNLOAD P1 VIDEO OUTPUT AFTER UNLOAD P2 VIDEO OUTPUT AFTER UNLOAD P3	These items specify whether to output the last picture or use "BLACK MUTING" after a file is closed. [black] : Black Muting. pb : Output the last picture.
630 631 632	ID CODE R1 ID CODE R2 ID CODE R3	Sets the ID CODE.
	SUB MENU	
	BYTE 0 BYTE 1 BYTE 2 BYTE 3	[0x00] .. 0xFF
633 634 635	BI TCG MODE R1 TCG MODE R2 TCG MODE R3	Sets the Time Code Generator.
	SUBMENU	
	ID CODE PRESET	Sets whether the ID CODE is registered. [USER BIT] : Registers the USER BIT without registering the ID CODE. ID CODE : Registers the ID CODE.
	REGEN MODE	Selects the regenerate signal when the Time Code Generator is in the regenerate mode. [TC] : Only TC is regenerated. UB : Only UB is regenerated. TC & UB : Regenerates TC and UB.
	REGEN / PRESET	Sets whether Time Code Generator regenerates. [REGEN] : Regenerates the time code. [PRESET] : Does not regenerate the time code.

### Expansion menu items (Continued)

Item number	Display indication	Settings	Description
633 634 635	INT / EXT  BI		Determines whether the time code generated by the time code generator, or whether the externally supplied time code is used for the record time code. INTERNAL : Time code generated by the Time Code Generator is used. EXTERNAL : Externally supplied time code is used.
	REC RUN / FREE RUN		Sets the timing for the start of transfer of the TCG regenerate. REC RUN : Transfer starts with REC. FREE RUN : Normal transfer.
	REGEN SOURCE		Sets the TC for generation of the original TCG. LTC : Generates from the LTC. VITC : Generates from the VITC.
	BINARY GROUP		Sets the user bit specifications of the time code generated by the Time Code Generator. 000 : Not specified : Character set not used. 001 : ISO character : 8-bit characters in compliance with ISO646, ISO2022 010 : Unassigned-1 : Undefined 011 : Unassigned-2 : Undefined 100 : Unassigned-3 : Undefined 101 : Page/line : SMPTE262M Page/Line Multiplex System 110 : Unassigned-4 : Undefined 111 : Unassigned-5 : Undefined
636 637 638	REC VITC SELECT R1 REC VITC SELECT R2 REC VITC SELECT R3  BI		Sets whether the time code can be output from the VITC time generator when recording is loaded. on : Switches to the VITC of the time code generator. off : Records the VITC of the input signal.
639 640 641	REC VITC POSITION R1 REC VITC POSITION R2 REC VITC POSITION R3  BI		Selects two lines to insert VITC during recording.
	SUB MENU		
	SELECT 1 SELECT 2	NTSC : 10 Line .. 16 Line .. 18 Line .. 20 Line PAL : 7 Line .. 19 Line .. 21 Line .. 22 Line	
642 643 644	PB TC REPLACE P1 PB TC REPLACE P2 PB TC REPLACE P3  BI		These items select the data that is output as VITC and LTC during playback. off : Output VITC and LTC from the recorded material. LTC : Output LTC from the recorded material for LTC and VITC. TM2 : Output TM2 from the recorded material for LTC and VITC.
645 646 647	PB VITC POSITION P1 PB VITC POSITION P2 PB VITC POSITION P3  BI		These items select two lines for inserting VITC during playback. (This items are valid only if LTC and TM2 were selected in items 642 to 644.)
	SUB MENU	NTSC : 10 Line .. 16 Line .. 18 Line .. 19 Line PAL : 7 Line .. 19 Line .. 21 Line .. 22 Line	
	SELECT 1 SELECT 2		
670 671	LTC SELECT R1 LTC SELECT R2  BI		These items select what to use as LTC input. SYSTEM TC : SYSTEM TIME CODE .. Selects the system time code. LINE INPUT : LINE INPUT .. Selects the LTC that is input to each port. When the configuration is 3 input/1 output, the R3 port is fixed to SYSTEM TIME CODE.
679	PB LTC OUTPUT  BI		Selects the player port's LTC output mode. normal : Outputs the LTC (speed 1x) of the current location. stop muting : When playback is stopped or paused, LTC output is muted.
701 702	INPUT SETUP REMOVE R1 INPUT SETUP REMOVE R2 (only in 525 mode)  BI		These items turn SETUP removal from the recording signal on or off. off on
704 705 706	OUTPUT SETUP P1 OUTPUT SETUP P2 OUTPUT SETUP P3 (only in 525 mode)  BI		These items specify whether to add SETUP to composite video output. off on

Expansion menu items (Continued)

Item number	Display indication	Settings	Description																							
712 713 714	NON COMPRESS LINE R1 NON COMPRESS LINE R2		During recording, excludes from compression the three largest scanning lines of the 1st Field and 2nd Field. The number of lines in the 1st and 2nd fields must be the same. <b>Note:</b> Set the sequence for continuous line settings as follows. NTSC : 10, 11, 12, 13, 14, 15, 16, 17, 18, 19, 20, 21, 273, 274, 275, 276, 277, 278, 279, 280, 281, 283, 284 PAL : 9, 10, 11, 12, 13, 14, 15, 16, 17, 18, 19, 20, 21, 22, 322, 323, 324, 325, 326, 327, 328, 329, 330, 331, 332, 333, 334, 335																							
	BI																									
	SUB MENU																									
	when in 525 mode	F1 SELECT 1 F1 SELECT 2 F1 SELECT 3	<input type="checkbox"/> : Compress. <u>10</u> line .. 21line : Exclude the specified scan lines from compression.																							
		F2 SELECT 1 F2 SELECT 2 F2 SELECT 3	<input type="checkbox"/> : Compress. 273line .. 284line : Exclude the specified scan lines from compression.																							
	when in 625 mode	F1 SELECT 1 F1 SELECT 2 F1 SELECT 3	<input type="checkbox"/> : Compress. 9line .. 22line : Exclude the specified scan lines from compression.																							
		F2 SELECT 1 F2 SELECT 2 F2 SELECT 3	<input type="checkbox"/> : Compress. 322line .. 335line : Exclude the specified scan lines from compression.																							
723 724 725	BLANK LINE SELECT P1 BLANK LINE SELECT P2 BLANK LINE SELECT P3		The method for processing the video signal during the vertical blanking intervals is specified for each line independently.																							
	BI																									
	SUB MENU																									
	when in 525 mode	All Lines	<input type="checkbox"/> : Specify line blanking for each line. thru : Turn off blanking for all lines that can be specified in this menu, regardless of the other SUB MENU settings. blank : Turn on blanking for all lines that can be specified in this menu, regardless of the other SUB MENU settings.																							
		Lines 10 .. 19	thru : Do not perform blanking. <u>blank</u> : Perform blanking.																							
		Line 20, 21	full : Perform blanking. <u>half</u> : Perform half-blanking. thru : Do not perform blanking. <b>Notes:</b> <ul style="list-style-type: none"> <li>Although the settings for LINE20 and LINE21 can be made as desired, actual operation will be as described in the following table. The underlined portions indicate special operations.</li> </ul> <table border="1" style="margin-left: auto; margin-right: auto;"> <thead> <tr> <th colspan="2"></th> <th colspan="3">LINE 20 SETTING</th> </tr> <tr> <th colspan="2"></th> <th>Thru</th> <th>Half</th> <th>Full</th> </tr> </thead> <tbody> <tr> <td rowspan="3">LINE 21 SETTING</td> <td>Thru</td> <td>20=Thru 21=Thru</td> <td>20=Half 21=Thru</td> <td>20=Full 21=Thru</td> </tr> <tr> <td>Half</td> <td>20=Thru 21=Half</td> <td>20=Half 21=<u>Thru</u></td> <td>20=Full 21=Half</td> </tr> <tr> <td>Full</td> <td>20=Thru 21=Full</td> <td>20=Half 21=<u>Thru</u></td> <td>20=Full 21=Full</td> </tr> </tbody> </table> <ul style="list-style-type: none"> <li>Initial settings: Line 20: "half", Line 21: "thru".</li> </ul>			LINE 20 SETTING					Thru	Half	Full	LINE 21 SETTING	Thru	20=Thru 21=Thru	20=Half 21=Thru	20=Full 21=Thru	Half	20=Thru 21=Half	20=Half 21= <u>Thru</u>	20=Full 21=Half	Full	20=Thru 21=Full	20=Half 21= <u>Thru</u>	20=Full 21=Full
		LINE 20 SETTING																								
		Thru	Half	Full																						
LINE 21 SETTING	Thru	20=Thru 21=Thru	20=Half 21=Thru	20=Full 21=Thru																						
	Half	20=Thru 21=Half	20=Half 21= <u>Thru</u>	20=Full 21=Half																						
	Full	20=Thru 21=Full	20=Half 21= <u>Thru</u>	20=Full 21=Full																						
	when in 625 mode	All Lines	<input type="checkbox"/> : Specify line blanking for each line. thru : Turn off blanking for all lines that can be specified in this menu, regardless of the other SUB MENU settings. blank : Turn on blanking for all lines that can be specified in this menu, regardless of the other SUB MENU settings.																							
		Lines 7 .. 22	thru : Do not perform blanking. <u>blank</u> : Perform blanking.																							
		Line 23	thru : Do not perform blanking. <u>half</u> : Perform blanking.																							

Expansion menu items (Continued)

Item number	Display indication	Settings	Description
726 727	BI DECODE Y/C SEP MODE R1 DECODE Y/C SEP MODE R2		The method for processing the video signal during the vertical blanking intervals is specified for each line independently.
	SUB MENU		
	when in 525 mode	All Lines <input type="checkbox"/> : Specify for each line according to other submenus. BPF : Perform Y/C color separation on all lines. B&W : Process as the luminance signal for all lines.	
		Lines 10 .. 21 BPF : Perform Y/C color separation. <input checked="" type="checkbox"/> B&W : Process as the luminance signal for all. However, for line 21 the default value is BPF.	
	when in 625 mode	All Lines <input type="checkbox"/> : Specify for each line according to other submenus. BPF : Perform Y/C color separation on all lines. B&W : Process as the luminance signal for all lines.	
		Lines 7 .. 22 BPF : Perform Y/C color separation. <input checked="" type="checkbox"/> B&W : Process as the luminance signal for all.	
744 745 746	BI VIDEO ADJUST RANGE P1 VIDEO ADJUST RANGE P2 VIDEO ADJUST RANGE P3		When the PROCESS CONTROL switch on the front panel is set to "LOCAL," these items select the variable range for the control that is used when VIDEO or CHROMA is selected on the front panel. <input checked="" type="checkbox"/> -3 .. +3dB wide
747 748 749	BI OUTPUT LEVEL CONTROL DATA P1 OUTPUT LEVEL CONTROL DATA P2 OUTPUT LEVEL CONTROL DATA P3		When the PROCESS CONTROL switch on the front panel is set to "MENU," these items specify the video output level. 0 .. <input checked="" type="checkbox"/> 400 .. 5A8
750 751 752	BI CHROMA OUTPUT LEVEL CONTROL DATA P1 CHROMA OUTPUT LEVEL CONTROL DATA P2 CHROMA OUTPUT LEVEL CONTROL DATA P3		When the PROCESS CONTROL switch on the front panel is set to "MENU," these items specify the chroma output level. 0 .. <input checked="" type="checkbox"/> 400 .. 5A8
753 754 755	BI CHROMA OUTPUT PHASE CONTROL DATA P1 CHROMA OUTPUT PHASE CONTROL DATA P2 CHROMA OUTPUT PHASE CONTROL DATA P3		When the PROCESS CONTROL switch on the front panel is set to "MENU," these items specify the chroma phase level. 62 .. <input checked="" type="checkbox"/> 80 .. 9E
756 757 758	BI CHROMA SETUP LEVEL CONTROL DATA P1 CHROMA SETUP LEVEL CONTROL DATA P2 CHROMA SETUP LEVEL CONTROL DATA P3		When the PROCESS CONTROL switch on the front panel is set to "MENU," these items specify the setup level (black level). 56 .. <input checked="" type="checkbox"/> 80 .. AA
759 760 761	BI SYSTEM PHASE COARSE P1 SYSTEM PHASE COARSE P2 SYSTEM PHASE COARSE P3		These items set the output video signal in 37ns steps. The range that can be set is -37µs to +37µs. 0 .. <input checked="" type="checkbox"/> 400 .. 7FF
762 763 764	BI SYSTEM PHASE FINE P1 SYSTEM PHASE FINE P2 SYSTEM PHASE FINE P3		These items set the output video signal in 0.14ns steps. The range that can be set is 0 to +37ns. <input checked="" type="checkbox"/> 00 .. FF
765 766 767	BI FREEZE MODE P1 FREEZE MODE P2 FREEZE MODE P3		This item sets how the video signal is output in slow motion playback <input checked="" type="checkbox"/> Field : Playback by fields. Frame : Playback by frames.

**Expansion menu items (Continued)**

Item number	Display indication	Settings Description
768 769 770	H BLANKING WIDTH P1 H BLANKING WIDTH P2 H BLANKING WIDTH P3  BI	These items select the horizontal blanking width for the video output signal. If analog blanking was selected, the horizontal blanking width conforms with the RS170A. The wider the blanking width, the narrower the picture is.  <b>narrow</b> : Digital blanking (narrow) <b>wide</b> : Analog blanking (wide)
778	SELECTION OF VIDEO/SYNC DELAY MONITOR  BI	Selects the video output phase that is set for PB/EE on the 013 Setup menu. <b>VIDEO DELAY</b> : Ignores video signal delays and adds the same sync as the output ref to the video output. In this case, the picture moves downward when in EE mode. <b>SYNC DELAY</b> : Adds a sync signal that is offset to match the video signal delay.
779 780 781	VAR CONROL P1 VAR CONROL P2 VAR CONROL P3  BI SUB MENU	These items set up the video process.
	Y ADD	This item specifies whether to forcibly turn Y ADD off in a playback mode other than normal playback mode (JOG, VAR, SHUTTLE, STILL, etc.). <b>auto</b> : Perform Y ADD automatically in any playback mode other than normal playback mode. <b>off</b> : Forcibly turn Y ADD off in any playback mode other than normal playback mode.
	ESR	When recording or playing back a composite signal, this item specifies whether to automatically turn the edge subcarrier reducer on/off in accordance with the playback mode, or to force the edge subcarrier reducer on (in order to play back a non-standard signal). <b>auto</b> : Turn the edge subcarrier reducer on/off in accordance with the playback mode. <b>on</b> : Force the edge subcarrier reducer on.
782 783 784	INTERNAL SIGNAL GENERATOR R1 INTERNAL SINGAL GENERATOR R2 INTERNAL SINGAL GENERATOR R3	These items select the test signal that is output from the internal signal generator. When off: No test signal is generated, and the unit operates normally. When not off: If an INPUT SELECT switch is held down for at least three seconds while lit, all INPUT SELECT switches light and the internal signal generator operates. The selected test signal is input to the REC port. It is also possible to record this signal. <b>off</b> : No test signal is generated. <b>CB100</b> : 100% color bar signal <b>CB75</b> : 75% color bar signal <b>CB75R</b> : 75% color bar (reverse) signal <b>BOW</b> : Bowtie signal <b>PLSBR</b> : Pulse and bar signal <b>MLTBS</b> : Multi-burst signal <b>HSWP</b> : HSWP signal (available only in 525 mode) <b>5STEP</b> : 5-step signal <b>RAMP</b> : Ramp signal <b>SH</b> : Shallow ramp signal <b>RED</b> : Full red signal <b>GRAY</b> : 50% flat signal <b>WHITE</b> : 100% flat signal <b>BB</b> : Black burst signal <b>SDI</b> : SDI check field signal <b>NTC7</b> : NTC7 test signal (available only in 525 mode) <b>LN330</b> : Line 330 test signal (available only in 525 mode)
785 786 787	INPUT VIDEO BLANK R1 INPUT VIDEO BLANK R2 INPUT VIDEO BLANK R3  BI SUB MENU	These items turn blanking during the input video signal vertical blanking interval on and off.

### Expansion menu items (Continued)

Item number	Display indication	Settings	Description
785 786 787	when in 525 mode  BI	All Lines  <input type="checkbox"/> thru  blank	: Specify line blanking for each line. : Turn off blanking for all lines that can be specified in this menu, regardless of the other SUB MENU settings. : Turn on blanking for all lines that can be specified in this menu, regardless of the other SUB MENU settings.
		Lines 10 .. 20 <input type="checkbox"/> blank	: Do not perform blanking. : Perform blanking.
	when in 625 mode	All Lines <input type="checkbox"/> thru  blank	: Specify line blanking for each line. : Turn off blanking for all lines that can be specified in this menu, regardless of the other SUB MENU settings. : Turn on blanking for all lines that can be specified in this menu, regardless of the other SUB MENU settings.
		Lines 7 .. 22 <input type="checkbox"/> blank	: Do not perform blanking. : Perform blanking.
788 789	VIDEO INPUT AGC/MANUAL R1 BI VIDEO INPUT AGC/MANUAL R2	<input type="checkbox"/> AGC MANUAL	These items select AGC ON/OFF (MANUAL) for the input video signal.
791 792	VIDEO INPUT MANUAL LEVEL R1 BI VIDEO INPUT MANUAL LEVEL R2	0 .. <input type="text" value="40"/> .. FF	These items specify the input video signal level when VIDEO INPUT AGC/MANUAL (menu 788, 789) are set to "MANUAL."
794 795 796	SELECTION OF VIDEO/SYNC DELAY P1 BI SELECTION OF VIDEO/SYNC DELAY P2 SELECTION OF VIDEO/SYNC DELAY P3	<input type="checkbox"/> VIDEO DELAY  SYNC DELAY	Selects the VIDEO OUTPUT phase for the EE mode. : Adds the same SYNC to the VIDEO OUTPUT as to OUTPUT REF while ignoring the video signal delay. In this case, in EE mode, an NTSC image moves down 4 lines, whereas a PAL image moves down 6 lines. : Attaches SYNC that matches the video signal delay.
797	VIDEO EDIT PREVIEW SWITCHER BI	<input type="checkbox"/> internal  external switcher	Sets the output phase of the video playback signal for the Edit Preset status. : Matches the output phase during EE. Set when previewing the MAV-555SS or while monitoring the VTR output signal. : Matches the internal or external video code. Set when switching the signal with the external switcher and Previewing.
801	AUDIO MONITOR OUTPUT MIXING B	<input type="checkbox"/> add <input type="checkbox"/> rms average	This item sets the mixing method for the digital audio or analog audio that is output from the SDI (SUPER) jack, the audio monitor out jack, and PHONE OUT. : Simple addition : Root mean square : Average
802	METER SCALE BI	<input type="checkbox"/> peak 0dB  ref 0dB	This item sets the mode for the display of the digital audio level. : Assume 0dB as the maximum level, and display the audio level as negative values. : Assume 0dB as the reference level, and display the audio level as positive and negative values.
803	AUDIO LEVEL METER DIMMER CONTROL BI	<input type="text" value="0"/> .. 7	This item sets the brightness of the audio level meter. : 0 is the brightest, 7 is the darkest.
804	AUDIO HEAD ROOM BI	<input type="text" value="20 dB"/> 18 dB 16 dB 14 dB 12 dB 15 dB 9 dB	This item sets the headroom for the audio level meter.
805	DIGITAL JOG SOUND BI	off  <input type="checkbox"/> muting +1.0	This item turns the digital jog sound on and off. : Digital channel audio is output without any speed compensation processing. : Audio is output after speed compensation processing is applied. : Muting while jog operation is in progress. : At settings other than +1.0, JOG is muting.



### Expansion menu items (Continued)

Item number	Display indication	Settings	Description
806 BI	SHUTTLE MUTING	<input type="checkbox"/> off <input type="checkbox"/> on	This item specifies audio muting during shuttle operations. : Audio is always output. : Muting is always applied.
809	AUDIO MONITOR MUTING	<input type="checkbox"/> normal <input type="checkbox"/> muting	This item specifies the muting of the audio output from the audio monitor. : Outputs audio normally. : Mutes the audio output.
820 BI	AUDIO OUTPUT MIXING	add average <input type="checkbox"/> rms	This item specifies the mixing method when mixing the audio output by the PB ports. : Simple addition : Average : Root mean square
821 822 823 BI	AUDIO OUTPUT CHANNEL P1 AUDIO OUTPUT CHANNEL P2 AUDIO OUTPUT CHANNEL P3 SUB MENU		These items make the settings for substituting, mixing and outputting the audio output by the PB ports on each channel.
	CHANNEL 1		Select from among none, <input type="checkbox"/> 1, 2, 12, 3, 13, 23, 123, 4, 14, 24, 124, 34, 134, 234, and 1234. The displayed channels are mixed and output.
	CHANNEL 2		Select from among none, 1, <input type="checkbox"/> 2, 12, 3, 13, 23, 123, 4, 14, 24, 124, 34, 134, 234, and 1234. The displayed channels are mixed and output.
	CHANNEL 3		Select from among none, 1, 2, 12, <input type="checkbox"/> 3, 13, 23, 123, 4, 14, 24, 124, 34, 134, 234, and 1234. The displayed channels are mixed and output.
	CHANNEL 4		Select from among none, 1, 2, 12, 3, 13, 23, 123, <input type="checkbox"/> 4, 14, 24, 124, 34, 134, 234, and 1234. The displayed channels are mixed and output.
824 BI	AUDIO EDIT PREVIEW SWITCHER	<input type="checkbox"/> internal external switcher	Sets the output phase of the Audio playback signal for the Edit Preset Status. : Matches the output phase during EE. Set when previewing the MAV-555SS or while monitoring the VTR output signal. : Matches the internal or external video code. Set when switching the signal with the external switcher and Previewing.
827 828 829 BI	AUDIO OUTPUT PHASE P1 AUDIO OUTPUT PHASE P2 AUDIO OUTPUT PHASE P3		Sets the output timing of the audio playback signal (SIF, AES/EBU only). With 0x100 as the reference, as it becomes smaller, the output timing comes earlier, and as it becomes larger, the output timing comes later. 0x000 .. <input type="checkbox"/> 0x100 .. 0x1ff
880 881 882 BI	INTERNAL AUDIO SIGNAL GENERATOR R1 INTERNAL AUDIO SIGNAL GENERATOR R2 INTERNAL AUDIO SIGNAL GENERATOR R2	<input type="checkbox"/> off silence 1 KHz sine 1 KHz-9 dB	Selects the device to generate the internal audio test signal. : No audio test signal is generated. : Silent signal. : Generates a sine wave of 1KHz - 20dB FS. : Generates a sine wave of 1KHz - 9dB FS. <b>When not off</b> For any selection other than “off”, press the INPUT SELECT button on the front panel to switch the button on, and then press and hold down the CH1 AUDIO INPUT button for 3 sec. or more to switch all of the digital audio input signals for all channels to the internal audio SG.
883 884 BI	EMPHASIS ON/OFF R1 EMPHASIS ON/OFF R2	<input type="checkbox"/> on <input type="checkbox"/> off	When the BKMA-513 optional board is installed, these items enable and disable pre-emphasis for each individual port.
886 887 888 BI	RATE CONVERTER R1 RATE CONVERTER R2 RATE CONVERTER R3	<input type="checkbox"/> enable disable	Specifies whether an audio AES/EBU rate converter is used. : Uses a rate converter. : Does not use a rate converter.
950 B	SS CAMERA SELECT	<input type="checkbox"/> sony other	Sets the input video format from cameras that support Super Slow. : Records video signals from standard format Sony cameras. : Records video signals from cameras other than standard format Sony cameras.
951 BI	SS AUDIO INPUT DELAY ADJUST	000 .. <input type="checkbox"/> 100 .. 1FF <b>Note:</b>	Sets the timing of the input audio signal with Super Slow recording. <b>Note:</b> If you set SS LIP SYNC ADJUST (menu 953) to on, be sure to adjust this setting.

Expansion menu items (Continued)

Item number	Display indication	Settings	Description
952	BI SS AUDIO MUTING	off <input type="checkbox"/> on	Specifies whether to use MUTING when playing back Super Slow files at 1/3 speed. off : Uses MUTING according to the settings in DIGITAL JOG SOUND (menu 805) and SHUTTLE MUTING (menu 806). on : Uses MUTING. <b>Note:</b> In 3/3 speed playback, this setting is off.
953	BI SS LIP SYNC ADJUST	off <input type="checkbox"/> on	Specifies whether to synchronize the audio and video phase when playing back Super Slow files. When synchronization is active, restrictions pertain to the frames that can be cued up. off : All the Super Slow file frames can be cued up. Because of the Super Slow signal's 3-frame sequence, it is only possible to synchronize the audio and video phase when cueing up to the first frame. on : The phase of the audio and video is synchronized during Super Slow file playback. However, cue up is limited to the first frame of the 3-frame sequence of the Super Slow signal.
954	BI SS NORMAL PLAY SPEED	1/3 3/3	When controlling in SD mode with the REMOTE port (9-pin), sets the playback speed of Super Slow files. 1/3 : Plays back at 1/3 speed. 3/3 : Plays back at 3/3 speed. When the conditions for this playback speed are not met, the playback speed is 1/3 speed. <b>Notes:</b> <ul style="list-style-type: none"> <li>• In SS mode, regardless of the settings made in this menu, playback with the BKMA-505 to port P1 is at 3/3 speed. It is possible to play back at 1/3 speed by turning the search dial.</li> <li>• In SD mode, regardless of the settings made in this menu, playback with the BKMA-505 is at 1/3 speed.</li> </ul> <i>For details about the BKMA-505, refer to the operation manual.</i>

### 3-4-4 Expansion Menu Operation

You can use the same setting operation in the Expansion menu as in the Basic menu.

For details of operation in the Basic menu, see Section 3-4-2, “Basic Menu Operation” (page 3-23).

**Note**

To access the Expansion menu requires the EM-3 board to be installed.

For details, refer to the Installation Manual.

### 3-4-5 System Time Settings

Set the system date and time as follows.

**Note**

If any input is present at the TIME CODE IN (SYSTEM) (page 2-9) connector on the connector panel, that input takes priority and the system time cannot be set as described below.

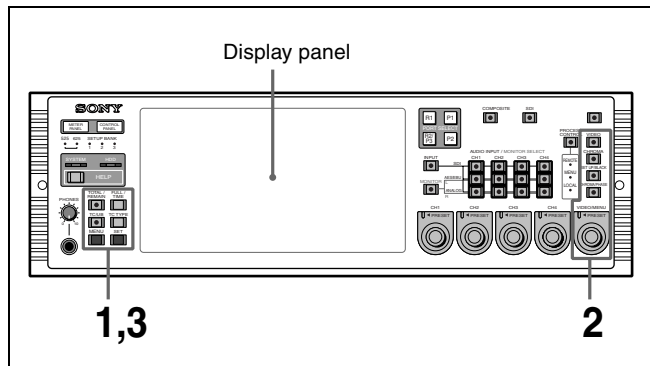

- 1 Simultaneously press the TIMER SEL and SET buttons for two seconds or longer. The current date and time settings appear in the upper time data display area on the display panel.

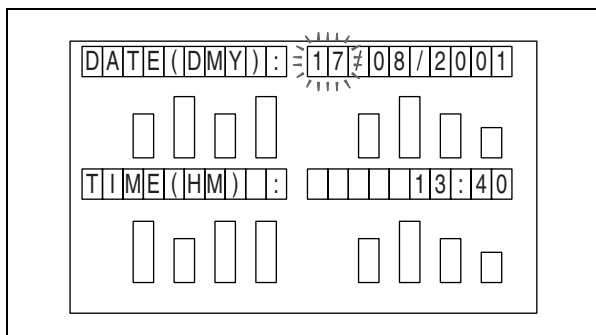

Date appears in the order day (D), month (M), and year (Y), and time appears as hour (H):minute (M).

- 2 Using the MENU knob, set each of the items day, month, year, hour, and minute in that order.
  - By turning the MENU knob, you can change the setting of the currently flashing item.
  - By pressing the MENU knob, you can move the flashing cursor to the next item.

- When you want to move the flashing cursor to the previous item, press the VIDEO button.

- 3 To set the changed date and time settings, press the SET button. To cancel the changes, press the MENU button instead of the SET button

**Note**

If you press the SET button while an invalid date is displayed, that setting will not be set. Repeat the above process.

## 3-5 Superimposed Character Information

When the CHARACTER switch on the system setup panel is turned ON, time values and text information indicating the operating mode are superimposed on the signals output from the SDI (SUPER) and ANALOG COMPOSITE (SUPER) MONITOR OUT connectors. The text information can also be superimposed on the P1, P2, P3 VIDEO OUT (COMPOSITE) B connectors by making a setting in the Setup menu.

### Note

To control the signal output from the ANALOG COMPOSITE (SUPER) terminal, specify SWITCH in Setup menu item 008 ANALOG MONITOR SUPERIMPOSE. This enables you to switch the output signal on and off by using CHARACTER SW.

### Character adjustment

You can adjust the position, size, and style of the superimposed characters in the setup menu.

For details, see Section 3-4, "Setup" (page 3-18).

### Displayed information

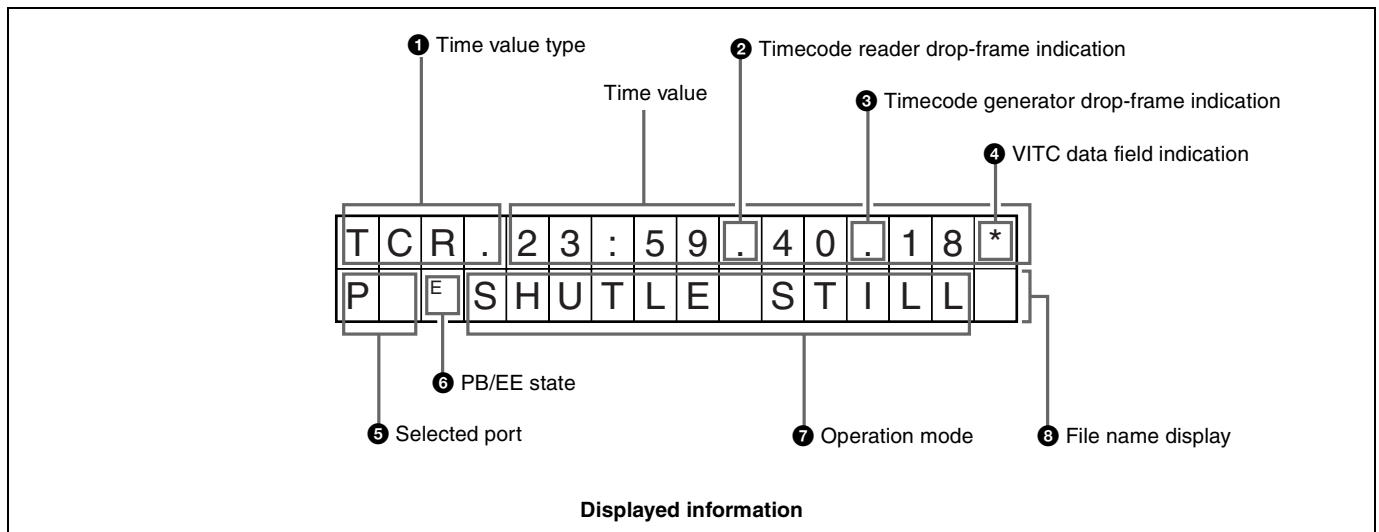

### Notes

- The above example shows the display with the factory default settings. By changing setup menu item 005 DISPLAY INFORMATION SELECT, you can change the type of time value shown in the second line.
- If the EE state is enabled when monitoring the P1 port in the DTR+Panel mode or the P1/P2 ports in the DTR+DTR mode, the time value display in ❶ above changes to R1/R2 port data.
- When outputting EE in the Panel mode, time data is displayed at ❶ above and the playback port data is left as it is.

**1 Time value type**

Indication	Meaning
TCR	Timecode value from LTC reader
TCR.	Timecode value from VITC reader
UBR	User bits from LTC reader
UBR.	User bits from VITC reader
TM1	Time value for TM1
TM2	Time value for TM2
TCG	LTC generator timecode value
TCG.	VITC generator timecode value
UBG	LTC generator user bit value
UBG.	VITC generator user bit value

**Note**

If the time data is not read correctly, the asterisk mark is displayed: “T\*R”, “T\*R.”

**2 Timecode reader drop-frame indication**

A period (“.”) indicates drop-frame mode (factory default).

A colon (“:”) indicates non-drop-frame mode.

**3 Timecode generator drop-frame indication**

A period (“.”) indicates drop-frame mode (factory default).

A colon (“:”) indicates non-drop-frame mode.

**4 VITC data field indication**

A blank indicates fields 1 and 3.

An asterisk (“\*”) indicates fields 2 and 4.

**5 Selected Port**

The currently selected port (R1, P1, R2, P2 or RP) is displayed. Also, when an external device is selected, “T1” or “T2” is displayed.

When RP is selected in BVE mode while monitoring R1, a small ‘P’ is displayed; and while monitoring P1, a small ‘R’ is displayed.

**6 PB/EE Status**

If the EE state is enabled when monitoring the playback port, a small ‘E’ is displayed here. This is not displayed when an external device is selected.

**7 Control VTR indication**

This part of the display is in two parts, A and B.

- Part A: operating mode
- Part B: tape speed

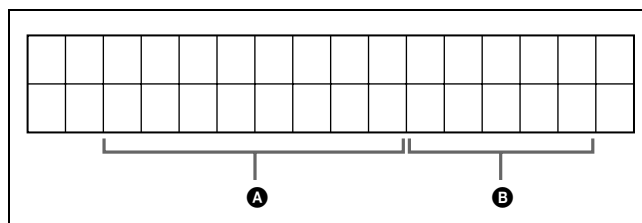
**Note**

Indications		Operating mode
Part A	Part B	
STOP		Stopped
F.FWD		Fast forward
REW		Rewind
PLAY	LOCK	Play
REC	LOCK	Recording
JOG	STILL	Still playback in jog mode
JOG	FWD	Forward playback in jog mode (▶ indicator lights)
JOG	REV	Reverse playback in jog mode (◀ indicator lights)
SHUTLE	(speed)	Shuttle mode
VAR	(speed)	Variable mode
PREROL		Preroll mode
EDIT	LOCK	Edit mode
STANDBY OFF*		Standby off mode
TAPE UNTHREAD*		Cassette not installed

\* Displayed only when an external device has been specified.

**8 File Name Display**

When superimposing on the VIDEO OUT (COMPOSITE) B terminal, the name of the file (up to 16 characters) loaded on the port can be displayed using the lower half of the display.

**Additional information displayed in the BVE mode**

When conducting nonlinear editing in the BVE mode, the port name of the port being monitored, IN point, OUT point, duration, edit channel, and the edit mode are displayed. The position of the display is set with the “323 Linear Edit Message” item in the Setup menu.

For details, see description of initial settings in Section 3-4, “Setup” (page 3-18).

The BVE mode display is shown below.

For details about the BVE mode display, see the MAVE-F555

Operation manual.

R	I	N		0	0	:	0	0	:	0	1	:	0	0		V	1	2	3	4	
		O	U	T		0	0	:	0	0	:	0	3	:	0	0					→←
		D	U	R		0	0	:	0	0	:	0	2	:	0	0					



# Chapter 4 Recording & Playback

## 4-1 Preparations for Recording

### 4-1-1 Switch Settings

Before recording, make any necessary switch settings. The relevant switches are shown in the following figure: refer to the pages shown in parenthesis.

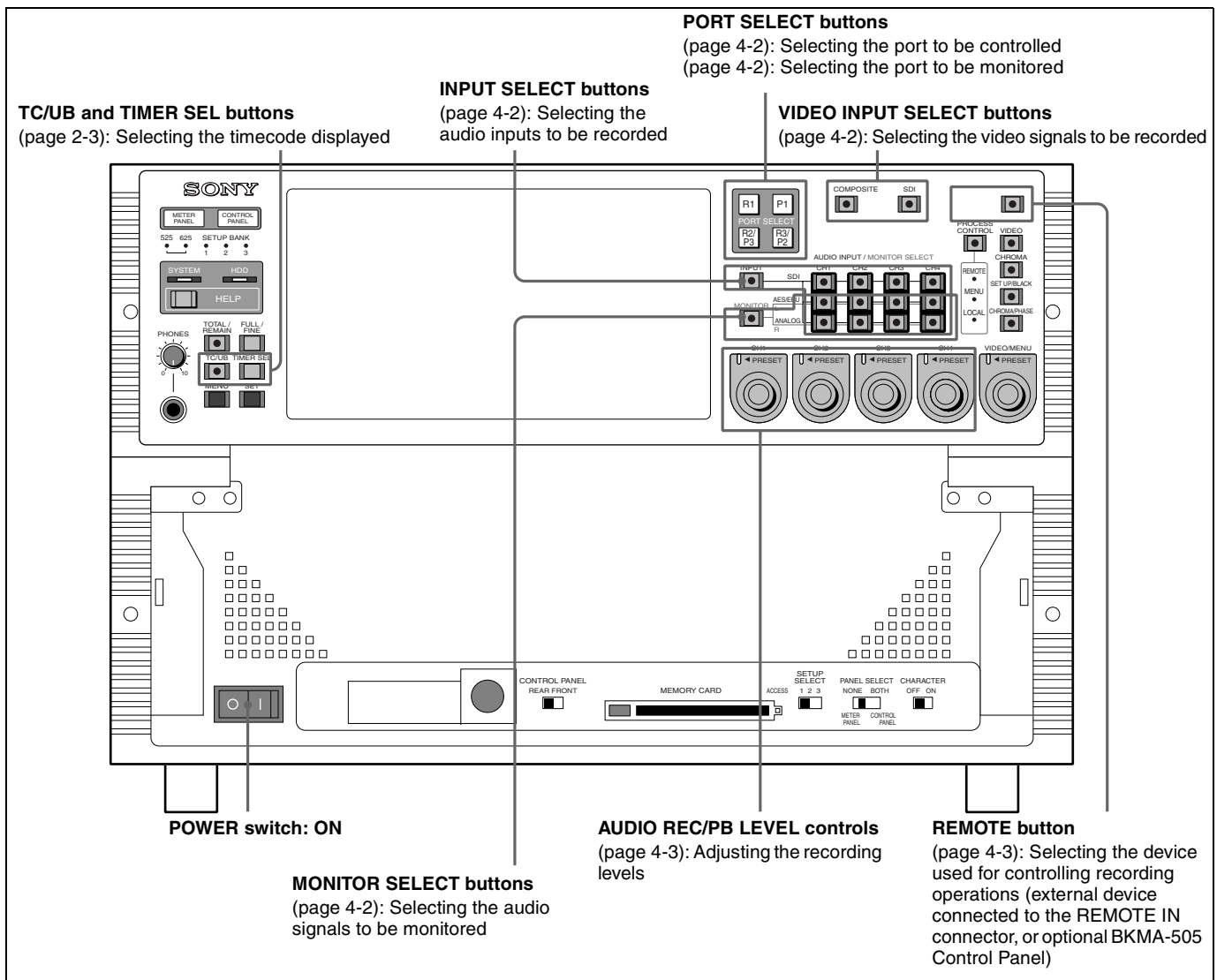

## 4-1-2 Selecting the Recording Port to be Controlled

Because the MAV-555SS can handle up to three recording ports, when making the various settings concerning recording that are described later in this chapter it is first necessary to specify which recording port is the target of the setting. (Settings must be made individually for each port.)

To select a recording port, press the PORT SELECT button that corresponds to that port so that the button is lit.

Mode	PORT SELECT button	Application	Configuration
SS mode	R1	Selecting the R1 port	1 input/ 1 output
SD mode	R2/P3	Selecting the R2 port	2 input / 2 output
			3 input / 1 output
	R3/P2	Selecting the R3 port	3 input / 1 output

## 4-1-3 Selecting the Video Signals

Set the VIDEO INPUT SELECT buttons by the following procedure, according to the video input signals.

- 1 With the PORT SELECT buttons, select the recording port to which the setting applies.
- 2 Press the SDI or COMPOSITE VIDEO INPUT SELECT button, turning it on.
  - SDI button:  
to select the signal input to the SDI INPUT connectors
  - COMPOSITE button:  
The optional AD/DA converter board BKMA-513 is required when selecting the signal input for the VIDEO IN (COMPOSITE) connectors.

## 4-1-4 Selecting the Audio Signals

Set the AUDIO INPUT/MONITOR SELECT buttons as follows, according to the audio input signals.

- 1 Press the PORT SELECT button to select the applicable recording port.
- 2 Press the INPUT SELECT button, turning it on. The AUDIO INPUT/MONITOR SELECT buttons which are lit show the current selection.
- 3 Use the following buttons to select the input channels. You can select input sources individually for each channel.

- SDI CH1 to CH4 buttons:  
signals input to the SDI INPUT connectors (channels 1 to 4)
- AES/EBU CH1 to CH4 buttons:  
signals input to the AUDIO INPUT (AES/EBU) connectors (channels 1 to 4)
- ANALOG CH1 to CH4 buttons:  
signals input to the ANALOG AUDIO INPUT connectors (channels 1 to 4)
- \* Requires the optional AD/DA Converter Board BKMA-513 and Analog Audio Extension Unit BKMA-570.

## 4-1-5 Selecting the Video and Audio Signals to be Monitored

This section describes how to select the video and audio signals to be monitored.

### Note

The video and audio signals in the monitor output are those of the currently selected port.

### Selecting the video signals to be monitored

The video signal of the currently selected port is output from the SDI (SUPER) and ANALOG COMPOSITE (SUPER) connectors.

Character information is superimposed on the outputs from these connectors.

*For details of settings relating to the superimposed character information, see Section 3-4-1, "Basic Menu Settings" (page 3-18).*

### Selecting the audio signals to be monitored

Using the AUDIO INPUT/MONITOR SELECT buttons, switch the audio signals output from the PHONES jack, SDI (SUPER) connector, and MONITOR OUTPUT L/R connectors, as follows.

- 1 Press the MONITOR SELECT button, turning it on. The AUDIO INPUT/MONITOR SELECT buttons that are lit show the current monitoring selection.
- 2 Press the corresponding buttons, turning them on, to select from channels 1 to 4 for the L and R monitoring channels (a channel can be assigned to both L and R).

### Notes

- The monitored audio signal uses the same port as the video signal.
- Audio signals output from the SDI (SUPER) connector are as follows:  
CH1: Audio monitor output. Same as the Lch signal.



CH2: Audio monitor output. Same as the Rch signal.  
CH3: No output.  
CH4: No output.

### To adjust the volume of the audio output from the PHONES jack

Turn the PHONES control.

## 4-1-6 Adjusting Recording Levels

### Note

Before performing the following operation, please select the applicable ports.

### To adjust the recording level

#### When recording with a reference level

Press the AUDIO REC/PB LEVEL adjustment control, so that the PRESET indicator lights. The audio signal is recorded at the preset reference level (shown as reference 0 dB for an input of +4 dBm).

#### To record with manual adjustment

For each channel, press the AUDIO REC/PB LEVEL adjustment control, so that the PRESET indicator goes off, then adjust so that the average sound level produces an indication on the level meter close to the 0 dB reference.

### Changing the display range of the audio level meters

By pressing the FULL/FINE button, you can switch the audio level meter display range.

FULL display mode:

the meter display range is -60 dB to 0 dB or -40 dB to +20 dB.

FINE display mode:

the meter display is enlarged, and a reference marker lights in the center of the meter, with the display in 0.25 dB steps.

To select the display range in the FULL mode, use Expansion menu item 802. See Section 3-4-3, "Contents of the Expansion Menu" (page 3-26).

## 4-1-7 Selecting the External Device Used for Controlling Recording Operations

Use the following procedure to determine whether you should use the optional control panel (BKMA-505) or an external unit when recording with the MAV-555SS.

- 1 With the PORT SELECT buttons, select the recording port to which the setting applies.
- 2 Press the REMOTE button, turning it on or off.

When lit:

The unit is controlled from the external unit connected to the REMOTE IN (P1/P2) connector on the unit's rear connector panel.

When off:

This unit is controlled from the optional control panel (BKMA-505).

## 4-1-8 Recording Analog Audio

### Using the emphasis function

To record audio signals input to the ANALOG AUDIO INPUT connectors of the BKMA-570 (optional), you can use the emphasis function.

To activate the emphasis function, set EMPHASIS ON in the Expansion menu (883 and 884).

For details of the Expansion menu, see Section 3-4-3, "Contents of the Expansion Menu" (page 3-26).

On playback, for a signal to which emphasis has been applied, regardless of the setting of the EMPHASIS switch, de-emphasis processing is automatically applied. Further, when recording digital audio signals (SDI or AES/EBU), emphasis is set automatically according to the input signal emphasis information. With this unit, this information cannot be changed.

# 4-2 Preparations for Playback

## 4-2-1 Switch Settings

Before starting playback, make any necessary switch settings. The relevant switches are shown in the following figure: refer to the pages shown in parenthesis.

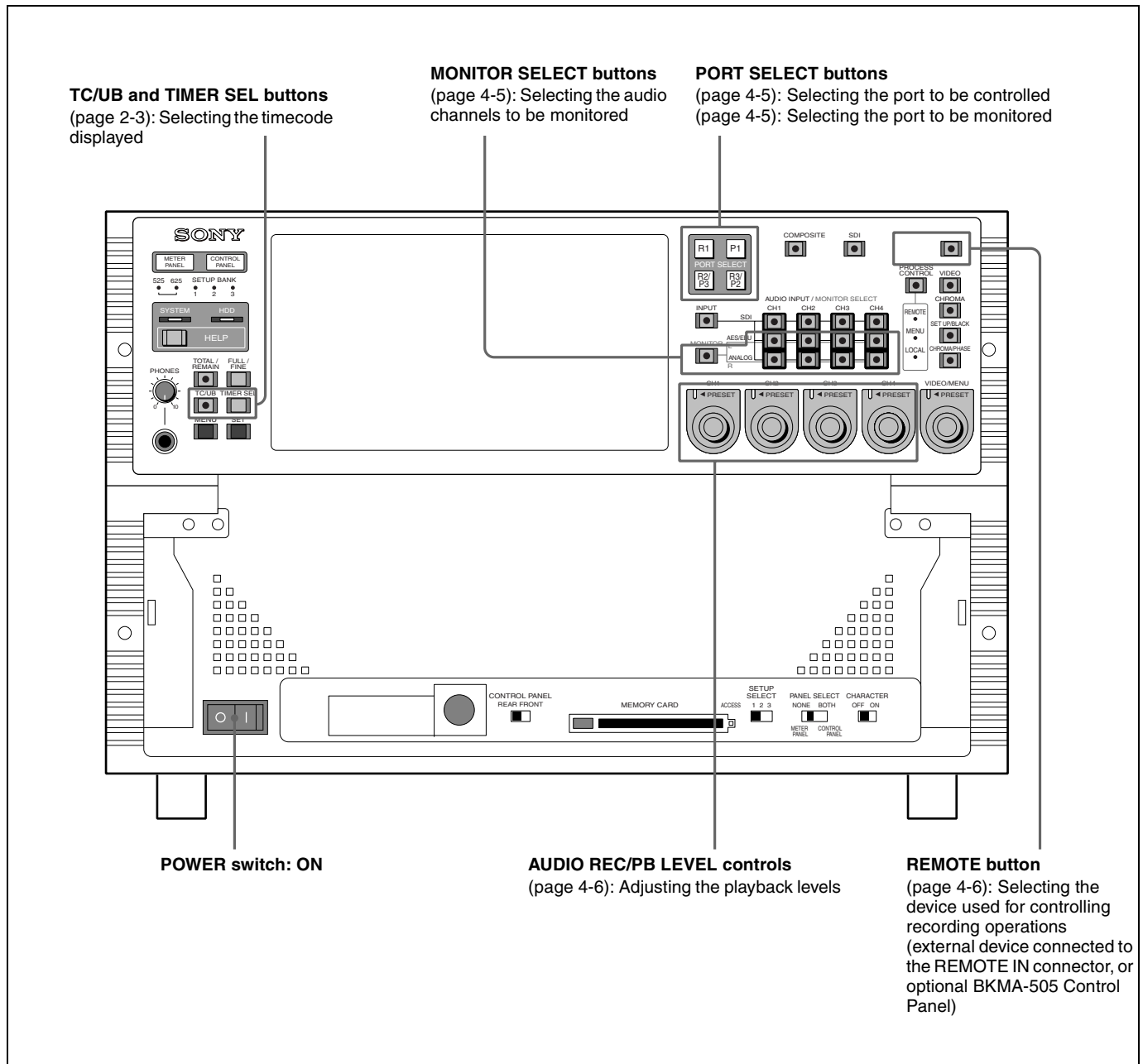

Chapter 4 Recording & Playback

## 4-2-2 Selecting the Playback Port to be Controlled

Because the MAV-555SS can handle up to three playback ports, when making the various settings concerning playback it is first necessary to specify which playback port is the target of the setting. (Settings must be made individually for each port.)

To select a playback port, press the PORT SELECT button that corresponds to that port so that the button is lit.

### Note

The PORT SELECT button that needs to be pressed in order to select a playback port depends on the port configuration selected on the menu, as described in the table below.

Mode	PORT SELECT button	Application	Configuration
SS mode	P1	Selecting the P1 port	1 input / 1 output
SD mode	R3/P2	Selecting the P2 port	2 input / 2 output
			1 input / 3 output
	R2/P3	Selecting the P3 port	1 input / 3 output

## 4-2-3 Selecting the Video and Audio Signals to be Monitored

This section describes how to select the video and audio signals to be monitored.

### Note

The video and audio signals in the monitor output are those of the currently selected port.

### Selecting the video signals to be monitored

The video signal of the currently selected port is output from the SDI (SUPER) and ANALOG COMPOSITE (SUPER) connectors.

Character information is superimposed on the outputs from these connectors.

*For details of settings relating to the superimposed character information, see Section 3-4-1, "Basic Menu Settings" (page 3-18).*

### Selecting the audio signals to be monitored

Using the AUDIO INPUT/MONITOR SELECT buttons, switch the audio signals output from the PHONES jack, SDI (SUPER) connector, and MONITOR OUTPUT L/R connectors, as follows.

- 1 Press the MONITOR SELECT button, turning it on. The AUDIO INPUT/MONITOR SELECT buttons which are lit show the current monitoring selection.
- 2 Press the corresponding buttons, turning them on, to select from channels 1 to 4 for the L and R monitoring channels (a channel can be assigned to both L and R).

### Notes

- The monitored audio signal uses the same port as the video signal.
- Audio signals output from the SDI (SUPER) connector are as follows:  
CH1: Audio monitor output. Same as the Lch signal.  
CH2: Audio monitor output. Same as the Rch signal.  
CH3: No output.  
CH4: No output.

### To adjust the volume of the audio output from the PHONES jack

Turn the PHONES control.

## 4-2-4 Selecting the Displayed Time Data

You can select the time data displayed in the time data indicator from the following:

- Time data
- User bits

### To display time data

To display time data, use the following procedure.

- 1 With the PORT SELECT buttons, select the playback port to which the setting applies.
- 2 Press the TC/UB button, turning it off.
- 3 Press the TIMER SEL button, to select the type of timecode you want to display. Each time you press the TIMER SEL button cycles through the following indications in the display panel for the playback port for which the setting is currently being made: LTC → VITC → TM1 → TM2 → LTC.

### To display user bits

To display user bits, use the following procedure. However, when time data is TM1 or TM2, the user bit does not appear.

- 1 With the PORT SELECT buttons, select the playback port to which the setting applies.
- 2 Press the TC/UB button, turning it on.

- 3 Press the TIMER SEL button, to select the type of user bits you want to display. Each time you press the TIMER SEL button switches between the following indications in the display panel for the playback port for which the setting is currently being made: LTC and VITC.  
When LTC appears, the LTC user bits are displayed, and when VITC appears, the VITC user bits are displayed.

### 4-2-5 Adjusting Playback Audio Levels

After choosing a playback port, if the AUDIO REC/PB LEVEL adjustment control is pressed so that the PRESET indicator lights, the audio signal is played back at the preset reference level (shown as reference 0 dB for an input of +4 dBm).

*For details of how to set the reference output level for the preset level (changing head room), refer to the Installation Manual.*

#### To adjust the playback level manually

For each channel, press the AUDIO REC/PB LEVEL adjustment control, so that the PRESET indicator goes off, then adjust to the desired level.

### 4-2-6 Selecting the External Device Used for Controlling Playback Operations

Use the following procedure to determine whether you should use the optional control panel (BKMA-505) or the DTR-3000 when recording with this unit.

- 1 With the PORT SELECT buttons, select the playback port to which the setting applies.
- 2 Press the REMOTE button, turning it on or off.  
When lit:  
The unit is controlled from the DTR-3000 connected to the REMOTE IN (P1/P2) connector on the unit's rear connector panel.  
When off:  
This unit is controlled from the optional control panel (BKMA-505).

## 4-2-7 Remotely Controlling the Video Processor

This section explains how to control the internal digital video processor with the HD Digital Video Controller HKDV-503/900 (sold separately).

- 1 Connect the HD Digital Video Controller HKDV-503/900 to the VIDEO CONTROL connector (D-SUB 25-pin) of the Connector Panel.  
*For details, refer to the HKDV-503/900 Installation Manual.*
- 2 Press the PROCESS CONTROL button to select REMOTE. The button lights.
- 3 Press the D2 button on the HD Digital Video Controller HKDV-503/900 to switch to the D2 mode and make VIDEO PROCESS settings. Furthermore, Unity values can be changed from setup menu items 747 to 764.

#### Note

- The HD Digital Video Controller HKDV-503 must be at least version 2.00, and the HKDV-900 must be at least version 1.10.
- With the MAV-555SS, CROSS COLOR cannot be adjusted

*For details about the setup menu, refer to Section 3-4, "Setup" (page 3-18).*

# Chapter 5

## Basic Functions of Each Mode

### 5-1 Motion Modes

As explained in Chapter 3, this unit has 2 motion modes: the SS mode (Sony Super Motion mode) and the SD mode (Standard Motion mode). Normal playback, recording, and editing are performed in SD mode. Recording and simultaneous playback from a Super Slow-compatible camera connected to the MAV-555SS are performed in SS mode.

This section explains how to change modes and the differences in the selection procedures.

#### 5-1-1 Changing the Motion Mode

The motion mode is selected using the Basic menu.

##### To change the motion mode

- 1 Select the desired mode or SD mode port configuration with the PORT CONFIGURATION (menu 042) Basic menu item.
- 2 Execute -FAST REBOOT (menu 027) in the Basic menu. Instead of executing -FAST REBOOT, you can restart the unit.

#### 5-1-2 Basic Operation with SS Mode

##### Available operation modes with SS mode

Unlike with SD mode when you can select any of the operation modes, with SS mode you can only select the Panel or DTR+Panel mode.

*For details about changing the operation mode and the basic operation with each operation mode, see sections 5-2 to 5-5. For an overview of each operation mode, see Chapter 3.*

##### Port configuration with SS mode

Regardless of the operation mode selected, only the 1 input/1 output configuration is available, with R1 as the recording port and P1 as the playback port.

##### Limitations with SS mode

- With Panel mode, Super Motion material being recorded with the optional BKMA-505 control panel cannot be edited with effects from the optional BKMA-560 or BKMA-561.
- With DTR+Panel mode, the file name appended automatically is LIVE\_SS.
- When changing from SD to SS mode, the possible remaining recording time for material assigned to the port becomes 1/3 of that in SD mode.
- EE signal outputs SS-A signals.
- In SS mode, a bridge connection at the SDI IN port is not possible.

---

## 5-2 Changing the Operation Mode

As described in Chapter 3, this unit has four operation modes: Panel Mode, DTR + Panel Mode, DTR + DTR Mode and BVE Mode. The operation mode is selected using the Basic menu.

### Note

'Control Panel' in this chapter refers to the optional BKMA-505 Control Panel, unless stated otherwise.

---

### To change the operation mode

- 1 Select the desired mode with the SYSTEM OPERATE CONFIGURATION (menu 019) Basic menu item.

- 2 Execute -FAST REBOOT (menu 027) in the Basic menu.  
Instead of executing -FAST REBOOT, you can also turn the unit off and back on.

*For Basic menu operations, please see Section 3-4-2, "Basic Menu Operation" (page 3-23).*

### Note

Before changing to DTR+Panel or DTR+DTR mode, the following operations must be performed in the Panel mode:

- Delete the material named "LIVE1" (and "LIVE2").
  - Execute the -ALL ERASE (menu 099) Basic menu item.
- Please refer to Section 5-4, "Basic Operations with DTR+Panel and DTR+DTR Modes" (page 5-3) for details.*

---

## 5-3 Basic Operation with Panel Mode

The Panel mode provides control of the unit from the Control Panel or the Player port of an editor.

*For details about playback in SS or SD mode of material recorded in SS mode, refer to the BKMA-505 operation manual.*

### 5-3-1 Recording Operation

Use the following procedure for recording in the Panel mode:

- 1 Press the R1 or R2 button to select the recording port.
- 2 Hold the REC key on the Control Panel, and press the PLAY key.
  - New recording material is created as recording starts. The name of the recording material is automatically assigned by the Control Panel.
  - Recording is indicated by a lit red disk in the status display on the display panel for the corresponding port being used for recording.

---

### To stop recording

To stop recording the current material, do the following.

- 1 Press the STOP key on the control panel. Recording to the material stops and the status display changes to ■.  
To continue recording using the same material name, hold down the REC key and press the PLAY key.  
To record using a new material name, before you start recording, hold down the SHIFT key and press B1 (Unload).

Recording to the material stops and the status display goes out. The next time you start recording, recording is done under a new media name.

### 5-3-2 Playback Operation

Use the following procedure for playback in the Panel mode:

- 1 Press PORT SELECT to select the playback port.
- 2 While holding the MODE button on the Control Panel, press L1 (Material) to set the Control Panel to the Material mode.
- 3 Turn the MULTI CONTROL knob to select the playing material, and press B1 (Load).  
A ■ mark appears in the status display on the display panel of this unit corresponding to the playback port selected in Step 1 to indicate playback is stopped.
- 4 Press the PLAY key on the Control Panel.  
Playback begins and the ► mark lights in place of the ■ mark.
- 5 Press the STOP key on the Control Panel to stop playback.

---

### Changing the playback material

Use the following procedure to change the playback material from that currently loaded:

- 1 While holding the SHIFT key on the Control Panel, press B1 (Unload).
- 2 Turn the MULTI CONTROL knob to select the next material to play, and press B1 (Load).

**Note**

Depending on the settings for the Control Panel, Step 1 may not be necessary.  
Please refer to the BKMA-505 Control Panel Operating Manual for details.

### 5-3-3 EE Signal Selection

In panel mode, when EE signal output has been specified for each playback port, it is possible to specify the recording port for which the EE value is to be output.

In order to make this specification, hold down the PORT SELECT button that corresponds to the target playback port, and then press the PORT SELECT button for the recording port for which the EE value is to be output.

- While the PORT SELECT button for a recording port is pressed, that EE signal is output. When the PORT SELECT button for that recording port is released, the output returns to the PB picture.
- Subsequently, if the EE picture output specification is made for this playback port, the input signal for the recording port that was specified by the initial operation is output as the EE picture.

**Note**

Combinations of ports that can be used with EE operation are as indicated by the circles in the table below.

		Playback port		
		P1	P2	P3
Recording port	R1	○	○	○
	R2	○	○	
	R3	○		

(Operation Example)

Outputting the R2 port signal when the EE specification is made for the P1 port:

- 1 While holding down the P1 key, press the R2 key. While the R2 key is held down, the R2 input signal is output to P1.
- 2 Press the R2 key. The display returns to the P1 PB picture. Subsequently, if the EE specification is made for the P1 port, the input signal for the R2 port is output as the P1 EE signal.

**Note**

In Expansion menu item REFERENCE SELECT (menus 349 to 351), when the recording port standard signal is set to “input video”, the EE picture is not output.  
For details about the setup menu, refer to Section 3-4, “Setup” (page 3-18).

## 5-4 Basic Operations with DTR+Panel and DTR+DTR Modes

In DTR+Panel mode, the R1 and P1 ports are controlled through the DTR-3000, while the other ports are controlled through the control panel or an external device. In DTR+DTR mode, R1/P1 and R2/P2 are each controlled separately through two DTR-3000s.

### 5-4-1 Initial Setup for DTR+Panel and DTR+DTR Modes

Before using the DTR+Panel and DTR+DTR modes, confirm and set up the following:

- (1) The DTR-3000 version connected to this unit must be CP:V01.30, VS:V01.20 or later.
- (2) The DTR-3000 must be set to the DISK:INDIVIDUAL mode.
- (3) The DTR-3000 recording time should be set on this unit.

- (4) Whether or not loop recording is used, it should be set on this unit.
- (5) Whether or not partial save is performed should be set on this unit.

Please contact your supplier or Sony representative if you require more details about (1) and (2) above. For more details on (3) and (4) above, please refer to the following operating information.

#### Setting the Recording Time from the DTR-3000

- 1 Set DTR-1 (and DTR-2) in LIVE DURATION (menu 034) on the basic menu to the desired time.

**2** Assuming it is okay to delete all material on this unit, execute ALL ERASE (menu 099) on the basic menu, and reboot the unit.

\* If you don't want to delete all material, change this unit to the Panel mode, delete the "LIVE1" (and "LIVE2") material, the change back to the DTR+Panel (or DTR+DTR) mode.

*For basic menu operations, please see Section 3-4-2, "Basic Menu Operation" (page 3-23).*

#### Note

After changing the recording time (LIVE DURATION), the materials must be deleted per Step 2 above. It is not possible to extend the recording time and continue recording from previously recorded material, or to otherwise change the recording time in the midst of recording.

*For precautions and setup related to LIVE DURATION, please see Section 3-4-1, "Basic Menu Settings" (page 3-18).*

## Loop Recording

During loop recording, when the recording time exceeds the time set for LIVE DURATION, the oldest recorded material is overwritten, so that even when the length of the recording exceeds preset recording time, the most recent recorded images are always stored up to the time set for LIVE DURATION.

Loop recording is performed by the following procedure:

- 1** Set the LIVE DURATION (menu 034) on the basic menu for DTR-1 (and DTR-2) to the desired time.
- 2** Set DTR-1 LOOP REC (or DTR-2 LOOP REC) on.
- 3** Assuming it is okay to delete all material on this unit, execute ALL ERASE (menu 099) on the basic menu, and reboot the unit.

\* If you don't want to delete all material, change this unit to the Panel mode, delete the "LIVE1" (and "LIVE2") material, the change back to the DTR+Panel (or DTR+DTR) mode.

*For basic menu operations, please see Section 3-4-2, "Basic Menu Operation" (page 3-23).*

#### Note

Once material has been recorded, loop recording cannot be turned on or off until the recorded material is erased.

## 5-4-2 Basic Operations in DTR+Panel and DTR+DTR Modes

After the initial settings described in the previous section, the following operations can be performed.

## Setting the preroll time in SS mode (DTR+Panel mode)

In SS mode, when setting the preroll time, it is necessary to specify a value three times larger than that of the desired time.

Examples

- When you want to specify 10 frames (525)  
Input [1S 00F] and the preroll time becomes 10 frames.
- When you want to specify 3 seconds  
Input [9S 00F] and the preroll time becomes three seconds.

## Recording from the DTR-3000

**1** While holding the SHIFT key, press the REC key on the DTR-3000.  
Recording starts at the recording port of this unit that is connected to the operating DTR-3000.

**2** To stop recording, hold the SHIFT key and press the STOP key on the DTR-3000.  
To resume recording, hold the SHIFT key while pressing the REC key again.

*Refer to the DTR-3000 Operating Manual for further details.  
The input signal can be verified at the output terminal by pressing the REC key by itself.*

## Re-recording from the beginning of the recording area

Recording cannot be restarted randomly within previously recorded material: it is always resumed from the point where it was last stopped. To re-record from the beginning of the recording area, perform the following procedure:

**1** Assuming it is okay to delete all material on this unit, execute ALL ERASE (menu 099) on the basic menu, and reboot the unit.

\* If you don't want to delete all material, change this unit to the Panel mode, delete the "LIVE1" (and "LIVE2") material, the change back to the DTR+Panel (or DTR+DTR) mode. However, if you want to retain previously recorded material, rename it to something other than "LIVE1" or "LIVE2."

**2** Follow the above steps for recording from the DTR-3000 to re-record.  
Recording starts at the beginning of the recording area.

## Playback from the DTR-3000

**1** Press the PLAY key on the DTR-3000.

- Playback starts at the playback port of this unit that is connected to the controlling DTR-3000.



- You can adjust the playback speed using the DTR-3000 Jog control.

Refer to the DTR-3000 Operating Manual for further details.

---

## Changing the playback material

The material for playback with DTR-3000 operations can be changed from the Control Panel.

Use the same procedure as for the Panel mode to change the material at the playback port (P1 or P2) being used for DTR-3000 operation.

For details on the procedure, refer to Section 5-3-2, “Playback Operation” (page 5-2).

---

## Editing from the optional BKMA-505 Control Panel

In the DTR+Panel mode, the R2, P2, P3 Port can be used from the control panel, so the materials being spliced/recorded with operation from the DTR-3000 can be edited using the existing materials in the MAV-555SS.

Even if the source material being loop recorded is overwritten by the Audio Channel mode loop recording with the Video/Audio mode, the referenced portion is not deleted.

Please refer to the BKMA-505 Operating Manual for editing procedures.

---

# 5-5 Basic Operations in BVE Mode

BVE mode is used for linear editing through an editor.

### Notes

- In BVE mode, set expansion MAXIMUM JOG SPEED (menu 107) to  $\times 1$ .
- BVE mode can be used only when the configuration is 2 input/2 output or 1 input/3 output.
- BVE mode does not permit editing through the control panel.
- In the BVE mode, the settings of the PB/EE SELECT (menu 013, 014) in the Basic menu correspond only to the PB/EE SELECT P1 (menu 013).
- When editing, set expansion REFERENCE SELECT (menu 349, 350, 351) to “output ref”.

## 5-5-1 Port Configuration

In BVE mode, the playback port (P1) is integrated with the recording port (R1), and can be used as a linear editing recorder. (The integrated recording/playback port is called the “RP port.”) When using a 2 input/2 output configuration, the R2 port becomes a collection-only port. When using a 1 input/3 output configuration, the P2 and P3 ports become playback-only ports.

---

## Saving part of the material during loop recording

During loop recording, if material is recorded beyond the time set as the LIVE DURATION, previously recorded material will be overwritten. If necessary, any part of the recorded material can be saved as follows to prevent it from being overwritten.

- 1 In GOOD SHOT PARAMETER (menu 030), change the AUTO SAVE setting to “cut up with data” and restart the set.
- 2 During recording, cue up to the part which you wish to save. The interval saved is the one set in SAVE DURATION on GOOD SHOT PARAMETER (menu 030), when the save duration starts at the cue point and the TRIM SIZE is added to both ends of the section.

### Notes

- Partial material will not be saved if available disk space is insufficient.
- Partial save is also possible when LOOP REC on LIVE DURATION is OFF (menu 034).

Files are loaded to the RP port and to the P2 and P3 ports from the control panel or the MAV-F555. The collection file is loaded automatically to the R2 port. (It is not possible to manually load any other file to this port.)

## 5-5-2 Basic Operation of the RP Port

The RP port is intended for use as a linear editing recorder. Once a file is loaded through the RP port, insert and assemble editing can be performed on that file just as with a normal recording/playback VTR.

Connect the RS-422 cable for the RP port to the REMOTE IN2 connector.

---

## Loading a File through the RP Port

### ■ When performing the operation through the control panel

- 1 Press the R1 button or the P1 button to select the RP port.

- 2 While holding down the MODE button on the control panel, press L1 (Material) to set the control panel to material mode.
- 3 Turn the MULTI CONTROL knob to select the material, and then press B1 (Load). The selected material file is loaded to the RP port, and can now be edited through the editor. The JOG, SHUTTLE and PLAY operations can also be performed through the control panel.

#### ■ When performing the operation through the MAVE-F555

- 1 Press the port assignment key on the MAVE-F555 to which the RP port was assigned.
- 2 Press the “+”/”-” keys on the MAVE-F555.

#### Notes

- A file in the process of being collected through the R2 port can be loaded to the RP port. However, the RP port is automatically set to REC INHIBIT, and the file cannot be saved or edited.
- CTL and TC can be used for the time code reference for the editor. Note that in order to use TC, set Expansion Menu “PB TC REPLACE” (menu 642, 643, 644) to “TM2” in order to output the TM2 data to LTC/VITC. When a MAVE-F555 is connected for nonlinear editing, the operation is carried out with TM2 as shown by the superimposed display. For the above settings, we recommend you select “TM2.”

### Loading a New File for Editing in the RP Port

#### ■ When performing the operation through the control panel

- 1 Press the R1 button or the P1 button to select the RP port.
- 2 If a file is loaded in the RP port, hold down the SHIFT key on the control panel and press B1 (Unload).
- 3 Hold down the SHIFT key on the control panel and press B1 (New Material).
- 4 A BLACK/MUTING file is created and is loaded to the RP port.
- 5 The file that is loaded to the RP port can be used for insert/assemble editing immediately.

#### ■ When performing the operation through the MAVE-F555

- 1 Press the R key in the port assignment section of the MAVE-F555.
- 2 Press the New File key on the MAVE-F555.  
*The overall size of the new file can be specified in the setup menu. For details, refer to Section 3-4, “Setup” (page 3-18). For details on control panel operation, refer to the BKMA-505 operation manual. For details on MAVE-F555 operation, refer to the MAVE-F555 operation manual.*

#### Note

The editor’s fast edit function cannot be used to collect a file through the RP port.

### Linear Editing through the RP Port

In order to perform linear editing through the RP port, load the file to the RP port and then perform insert/assemble editing through the editor. If the MAV-555SS detects the end of editing through the editor, an editing results file is created in the MAV-555SS and is automatically loaded to the RP port. The output picture momentarily goes to black.

#### Notes

- During insert/assemble intervals in RECORDER material, LTC/VITC are replaced with those of the PLAYER. In order to consecutively replace the time codes from the editing results file, set Expansion menu “PB TC REPLACE” (menu 642, 643, 644) to “TM2” in order to output the TM2 data to LTC/VITC. When a MAVE-F555 is connected for nonlinear editing, the operation is carried out with TM2 as shown by the superimposed display. For the above settings, we recommend you select “TM2.”
- The REMOTE setting on the P side is valid. Select the P1 port first, and then set REMOTE.

### Manual Recording through the RP Port

Manual recording through the RP port is possible through the following procedure:

- 1 Press the R1 button or the P1 button to select the RP port.
- 2 Use the control panel to load a file to the RP port.
- 3 Cue up the position in the file from which you wish to begin recording manually.
  - You may begin recording from any position within the file. You cannot, however, specify a recording start position that is outside of the recorded length of the file.

- 4 To begin recording, hold down the REC key on the control panel and then press the PLAY key.
  - Recording starts from the cued up position in the file that is currently loaded. Previously recorded contents are overwritten.
- 5 To stop recording, press the STOP key.
  - The STOP key can also be pressed after the length of the original file has been exceeded.
  - Pressing the STOP key is the only way to halt recording; pressing PLAY or any other keys will not halt recording.

### 5-5-3 Basic Operation of the R2 Port

In BVE mode, the R2 port is a collection-only port. Immediately after the MAV-555SS is started up in BVE mode, the recording file is automatically loaded to the R2 port; recording may then begin at any point thereafter.

---

#### Collecting through the R2 Port

##### ■ When performing the operation through the control panel

- 1 Press the R2 button on the control panel to select the R2 port.
- 2 While holding down the REC key on the control panel, press the PLAY key. Recording begins. While recording is in progress, a red ● lights in the status display area for the R2 port on the display panel.
- 3 To stop recording, press the STOP key. Recording stops and the red ● in the status display area disappears. Recording can be resumed at any time by holding down the REC key and pressing the PLAY key. Repeatedly starting and stopping recording will produce sequential collection at the end of the same file.

##### ■ When performing the operation through the MAVE-F555

- 1 Press the ► key and the ● key on the MAVE-F555 simultaneously.
- 2 To stop recording, select the BG port and then press the ■ key. Repeatedly starting and stopping recording will produce sequential collection at the end of the same file.

---

### Replacing Files through the R2 Port

#### ■ When performing the operation through the control panel

Follow the procedure described below through the control panel in order to replace the file collected in the R2 port with a new file.

- 1 Press the R2 button on the control panel to select the R2 port.
- 2 On the control panel, hold down the SHIFT key and press B1 (Unload). The file is unloaded and a new file for collection is automatically loaded to the R2 port in its place.

#### ■ When performing the operation through the MAVE-F555

When performing the replacement operation through the MAVE-F555, press the ■ key while holding down the ● key in order to first unload the file collected in the R2 port and then replace it with a new file. When performing this operation, the BG port must be selected and the unit must not be recording.

#### Note

If you have just collected important information, be sure to confirm the file number and file name in the R2 port before unloading the file.

In addition, when using the control panel, we recommend using the RENAME function to change the file name while recording is in progress. When using the MAVE-F555, we recommend registering the file with the MEMORY key.

*For details on control panel operation, refer to the BKMA-505 operation manual.*

*For details on MAVE-F555 operation, refer to the MAVE-F555 operation manual.*

### 5-5-4 Basic Operation of the P2 and P3 Ports

The P2 port operates in the same manner in BVE mode as it does in panel mode. It can be used as the PLAYER side for linear editing and as an output port. When using a 2 input/2 output configuration, the file being collected through the R2 port can also be loaded to the P2 port. Furthermore, when using a 1 input/3 output configuration, output through the P3 port can be controlled through the control panel or the MAVE-F555.

Connect the RS-422 cable for the P2 port to the REMOTE IN4 connector.

Connect the RS-422 cable for the P3 port to the REMOTE IN3 connector.

## Playback through the P2 and P3 Ports

### ■ When performing the operation through the control panel

- 1 Press the PORT SELECT button on the control panel to select either the P2 or P3 port.
- 2 On the control panel, hold down the MODE button and press L1 (Material) to set the control panel to material mode.
- 3 Turn the MULTI CONTROL knob to select the material to be played back, and then press B1 (Load).
  - You can also select to load the file that is being collected through the R2 port.
  - When the load operation is executed, ■ lights in the status display for the P2 or P3 port on the display panel of the MAV-555SS, indicating that playback is paused.
- 4 Press the PLAY key on the control panel. Playback begins, the indicator changes to ►, indicating that playback is in progress.
- 5 To stop playback, press the STOP key on the control panel.

### ■ When performing the operation through the MAVE-F555 (P2 Port)

- 1 Press the port assignment key on the MAVE-F555 that is assigned to the P2 port.
- 2 Press the “+”/“-” keys on the MAVE-F555 to select the file.
- 3 Press the PLAY key on the linear editor or the control panel. To stop playback, press the STOP key on the linear editor or the control panel.

### ■ When performing the operation through the MAVE-F555 (P3 port)

- 1 Press the BG key on the MAVE-F555.
- 2 Press the “+”/“-” keys on the MAVE-F555 to select the file.
- 3 Press the ► key on the MAVE-F555. To stop playback, press the STOP key on the MAVE-F555.

## 5-5-5 New File Names

When files are collected on the R2 Port, and new files are assigned to the RP Port, they are assigned new file names as shown below.

R2 Port Collection	BG#XXXX
RP Port New Files	NEW#XXXX

\*Where “XXXX”, a simple 4-digit number, is added.

When copying existing files, a number is added at the end of the original file name.

Example: Executing Load Copy on a file named “Program”

First time Load Copy is executed: Program.1

Second time Load Copy is executed: Program.2

Third time Load Copy is executed: Program.3

If, in the case of the above example, the Load Copy operation is performed directly on the file “Program.2”, the system will attempt to create “Program.3”. However, since “Program.3” already exists, the system will start a new branch of numbers as follows:

First time Load Copy is executed: Program.2A.1

Second time Load Copy is executed: Program.2A.2

The last digit at the end of the file name indicates the number of times Load Copy was executed, while the portion of the name preceding the last “dot” indicates the original file name. If multiple branches of duplicates are made from the original file, a letter is inserted before the last “dot” in the file name.

### Note

If Load Copy is executed repeatedly, the file names will gradually become longer; if it is no longer possible to add more characters, the name “%LongName” will be used. In addition, if all branches have been used (i.e., Load Copy has been used to generate file names from “ProgramA.1” to “ProgramZ.1”) the name “%MaxBranch” will be used. Because these alternate names do not bear any relation to the name of the original file, rename such duplicates with a shorter file name as soon as possible.

## 5-5-6 Monitoring the RP Port

When either the R1 or P1 key is pressed, both R1 and P1 light to indicate that the RP port is selected. However, the monitored output differs according to which key was pressed.

### When the R1 key was pressed

In this status, you will see “Inp Adj” displayed in the upper left corner of the display panel.

Signals applied to the R1 input terminal are also present at the monitor output. The status is the same as INPUT CHECK with a VTR.

Audio volume and input signal selection at the meter panel apply to the recording material for INSERT/ASSEMBLE operation.

## When the P1 key was pressed

The signal supplied to the R1 port is output in the EE status when the monitor output is an RP port playback signal, or when PB/EE has been specified.

Audio volume and video process level at the meter panel apply to the playback signal.

After pressing the P1 key, perform REMOTE setup of the RP port. REMOTE mode

## 5-5-7 Pre-roll Time

When using this unit as the player during DMC editing, the setting should be at least five seconds.

Also, with DMC editing, the insertion point may be displaced by one frame.

## 5-5-8 File Backup Function

If the power to the MAV-555SS is accidentally cut while you are editing a file, the "Backupxxxxx" file (where xxxxx is the date, for example: 05.20-14:00) is automatically created. Therefore, if this happens and the edited file is deleted, you can continue editing using the backup file. However, if the edited file is unloaded before the power is cut, backup is not possible. Further, because the cut point information is not saved along with the backup file, you cannot perform cut jumps or trim cuts in this file.

You can unload files from the MAV-D555 and BKMA-505.

*For details about unloading files, refer to the MAV-D555 and BKMA-505 operation manuals.*

## 5-5-9 Editing-Related Error Messages

There are some unique editing function-related errors which may occur in BVE mode that do not exist in other modes. These error messages and their remedies are described below.

### [Cut Entry Full]

In BVE mode, cut information for the file being edited is stored internally. Although this information cannot be used in linear editing, it can be used as cut information for nonlinear editing when the MAV-F555 is connected.

There is a limit on the number of cuts per file. The [Cut Entry Full] error appears when this limit has been reached, and indicates that the file in question cannot be edited any further.

#### Remedy:

- When the above error is generated, follow the instructions that are provided in the dialog box that appears on the control panel. Doing so will clear the cut information for that file, making further editing on the file possible.

- This error can be avoided by performing certain operations through the MAV-F555. For details, refer to the "Error Message List" in the appendix in the MAV-F555 operation manual.

### [Edit Entry Full]

The internal area where cut information is stored limits the number of files that can be stored. The [Cut Entry Full] error appears when this limit has been reached, and indicates that no more files can be created for editing. Because an internal temporary file is created when editing through the RP port, editing is no longer possible once this error has been generated.

#### Remedy:

- When the above error is generated, follow the instructions that are provided in the dialog box that appears on the control panel. Doing so will clear the internal cut information area, making further file creation and editing possible.
- This error can be avoided by performing certain operations through the MAV-F555. For details, refer to the "Error Message List" in the appendix in the MAV-F555 operation manual.

### [Rec Inhibit]

This error is generated if an attempt was made to record or edit while the recording port or RP port was in the "Rec Inhibit" state, or an attempt was made to record or edit a file with file protection on.

#### Remedy:

Cancel "Rec Inhibit" or file protection in order to record or edit.

### [Material Entry Full]

The MAV-555SS material management information is full; no files can be created.

#### Remedy:

Unneeded files are deleted.

### [Nearly Rec Stop]

When editing or recording a collection file in BVE mode, a four-minute area is allocated on the HDD; then, as recording continues, when two minutes of this allocated area is used up, enough area for two more minutes is allocated. This operation repeats as recording continues. This error occurs when the area for two additional minutes cannot be allocated because the disk is full. Once this error is generated, recording/editing stops after two minutes.

#### Remedy:

- Recording/editing can continue further even after this error is generated if you delete any unnecessary files within two minutes of the moment when this error was generated.

- This error can be avoided by performing certain operations through the MAVE-F555. For details, refer to the “Error Message List” in the appendix in the MAVE-F555 operation manual.

[Rec Stopped]

This error is generated if nothing is done during the two minutes after [Nearly Rec Stop] is generated. The disk is now full, and further recording/editing is not currently possible.

Remedy:

Delete any unnecessary files.

The next recording operation in the R port will begin from the start of a new file.

The next manual recording operation in the RP port will begin from the point where recording was halted.

Editing in the RP port stops automatically, and a new editing command must be issued.

[Not Enough Space To Rec]

Because the disk is full, there is not enough space to automatically allocate a four-minute area. Recording/editing is not possible.

Remedy:

Create free space by deleting any unnecessary files.

Once free space has been created, the four-minute area will be allocated automatically and the error will be cancelled.

[Too Much Fragmentation]

Too many fragmented files have been recorded on the HDD and the limit of processing has been exceeded.

Remedy

From the playback port play back the files that you have been editing, then by recording the files as new files on the recording port you can continue editing.

[Temp. File Protected]

The temporary file that you are using in the BVE mode has been protected in another mode.

Remedy

In any mode other than BVE mode, check the names of the files. If any file is prefixed with a percent symbol (%), set Protect Off.

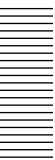

# Appendixes

## Error Messages

If a malfunction or internal system error/warning occurs and the MAV-555SS unit fails to function properly, the SYSTEM indicator or HDD indicator on the front panel lights up red. In addition, when an error occurs, an error message immediately appears on the time data display on the front panel. When a warning occurs, you can check the details by pressing the HELP button.

If an error or warning occurs, refer to the list below and, if a remedy is indicated, follow the instructions given. Errors and warnings can often be corrected by turning the POWER switch off and then back on again.

If an error or warning still occurs after restarting the unit, please contact the company from which you purchased the unit.

---

### Error

#### Power Trouble

Meaning: Detected a malfunction in the power supply unit.  
Power supply may be defective.

#### EM Board Not Respond

Meaning: Normally: Detected a malfunction in communications between the EM-3 Board and other boards. Thought to be an EM-3 Board malfunction.  
When booting: Failed to boot the EM-3, DM-127, or FM-81 board. A board may be defective.

#### FM Board Not Respond

Meaning: Detected a malfunction in communications between the FM-81 Board and other boards. The FM-81 Board may be defective.

#### R1 Port Not Respond

Meaning: Detected a malfunction in communications between R1 port control and other boards. The DM-127 Board may be defective.

#### R2 Port Not Respond

Meaning: Detected a malfunction in communications between the R2 port control area and other boards. The DM-127 Board may be defective.

#### R3 Port Not Respond

Meaning: A communications problem was detected between the R3 port controller and the other boards. The DM-127 Board may be defective.

#### P1 Port Not Respond

Meaning: An abnormality has been detected in a data transfer between the P1 port control area and another board. The DM-127 Board may be defective.

#### P2 Port Not Respond

Meaning: Detected a malfunction in communications between P2 port control and other boards. The DM-127 Board may be defective.

#### P3 Port Not Respond

Meaning: A communications problem was detected between the P3 port controller and the other boards. The DM-127 Board may be defective.

#### SLOT3 Not Respond

Meaning: Detected a malfunction in communications between the optional BKMA-540 and some other board. The BKMA-540 may be defective.

### **RAID Com. Error**

Meaning: Detected a malfunction in communications between the RAID control display and the FM-81 Board.  
The PU-121 Board or FM-81 Board may be defective.

### **RAID Error**

Meaning: Detected malfunctions in two or more HDDs making up the RAID.  
Recording and playback do not run correctly.  
By pressing HELP, you can view the numbers of HDDs displaying warnings.

---

## **Warning**

### **Fan1 Trouble**

Meaning: Detected a malfunction in the left fan unit (as viewed when facing the rear panel).  
The fan unit may be defective.

### **Fan2 Trouble**

Meaning: Detected a malfunction in the central fan unit (as viewed when facing the rear panel).  
The fan unit may be defective.

### **Fan3 Trouble**

Meaning: Detected a malfunction in the right fan unit (as viewed when facing the rear panel).  
The fan unit may be defective.

### **Ref. Missing**

Meaning: Reference signal is not input.  
Remedy: Input the reference signal.

### **Ref. Not Lock**

Meaning: Cannot synchronize with the reference signal.  
The reference signal or FM-81 Board may be defective.  
Remedy: Confirm that the reference signal and “525/625” (menu 010) settings on the base menu are correct. If they are correct, the FM-81 Board may be defective.

### **DM1 File Open Fail**

Meaning: Upon startup, failed to allocate space for the LIVE1 material (in SS mode, LIVE\_SS) for R1 and P1 ports in DTR+PANEL or DTR+DTR mode. R1 and P1 ports cannot be controlled from the DTR-3000. A recording time exceeding recording capacity may be set for LIVE DURATION (menu 034) on the basic menu.

Remedy: Press the TOTAL/REMAIN button and confirm the settings for SysRemain (HDD available space) and “LIVE DURATION” (menu 034) on the basic menu. When the operation mode is DTR+Panel, this warning occurs if the “LIVE DURATION” setting for DTR-1 exceeds

SysRemain. When the operation mode is DTR+DTR, this warning occurs if the LIVE DURATION settings for DTR-1 plus DTR-2 plus three minutes exceeds SysRemain. Correct the LIVE DURATION settings, then reboot the unit.

### **DM2 File Open Fail**

Meaning: Upon startup, failed to allocate space for the LIVE2 material for R2 and P2 ports in DTR + DTR mode. R2 and P2 ports cannot be controlled from the DTR-3000. A recording time exceeding recording capacity may have been set for LIVE DURATION (menu 034) on the basic menu.

Remedy: See “DM1 File Open Fail.”

### **EM Board Warning**

Meaning: Detected a malfunction on the EM-3 Board.  
The EM-3 Board may be defective.

### **FM Board Warning**

Meaning: Detected a malfunction on the FM-81 Board.  
The FM-81 Board may be defective.

### **FM Battery Warning**

Meaning: Detected a malfunction in the battery that maintains settings on the FM-81 Board.  
The battery may be discharged.

### **R1 port Warning**

Meaning: Detected a malfunction in the R1 port control area.  
The DM-127 Board and DPR-189(A) Board may be defective.

### **R2 port Warning**

Meaning: Detected a malfunction in the R2 port control area.  
The DM-127 Board and DPR-189 (B) Board may be defective.

### **R3 port Warning**

Meaning: Detected a malfunction in the R3 port control area.  
The DM-127 Board and DPR-189 (B) Board may be defective.

### **P1 port Warning**

Meaning: Detected a malfunction in the P1 port control area.  
The DM-127 Board and DPR-189 (A) Board may be defective.

### **P2 port Warning**

Meaning: Detected a malfunction in the P2 port control area.  
The DM-127 Board and DPR-189 (B) Board may be defective.



### **P3 port Warning**

Meaning: Detected a malfunction in the P3 port control area.

The DM-127 Board and DPR-189 (B) Board may be defective.

### **RAID SBX(U) Warning**

Meaning: Detected a malfunction in communications between the FM-81 Board and RAID.

The FM-81 Board and PU-121 Board may be defective.

### **RAID SBX(D) Warning**

Meaning: Detected a malfunction in communications with the FM-81 Board in the PU-121 Board.

The FM-81 Board and PU-121 Board may be defective.

### **RAID Battery Warning**

Meaning: Detected a malfunction in the battery that maintains PU-121 Board settings.

The battery may be discharged.

### **RAID Flash Warning**

Meaning: A Flash ROM malfunction detected in the PU-121 Board.

The PU-121 Board may be defective.

### **HDD xx Warning**

Meaning: Errors occur frequently while reading/writing HDD number xx.

### **HDD xx Fail**

Meaning: HDD number xx cannot be used due to malfunction.

### **HDD xx Unknown HDD**

Meaning: HDD number xx has not been recognized yet. This message appears when a new replacement HDD is inserted.

Remedy: Run -NEW HDD (menu 098) from the base menu and restore AV data to the new HDD. During restoration, "Rebuilding" is displayed on the front panel. Do not turn off the power until restoration is complete.

### **HDD xx SPC Error**

Meaning: SPC connected to HDD number xx is not usable due to malfunction.

The IF-837 Board may be defective.

### **HDD xx No HDD**

Meaning: No HDD is inserted in HDD slot number xx.  
EM Router Init. Fail

### **EM Router Init. Fail**

Meaning: The video router on the EM-3 board cannot be initialized. The EM-3 board may be defective.

### **TM Warning LTC**

Meaning: Either the correct time code signal is not being input to the TIMECODE IN (SYSTEM) jack on the rear panel, or there may be a hardware problem with the LTC Reader IC on the FM-81 board.

\* Only a 1× time code signal can be input to the TIMECODE IN (SYSTEM) jack.

Remedy: Check the signal that is being input to the TIMECODE IN (SYSTEM) jack. If the correct signal is being input, there may be a hardware problem with the LTC Reader IC (IC1101) on the FM-81 board.

### **EM Recorder Init. Fail**

Meaning: Was unable to initialize the RP port on the EM-3 board in the BVE mode.

### **EM Mixer Config Fail**

Meaning: Detected a malfunction in communications between the EM-3 Board and the DSP.

The EM-3 Board may be defective.

### **Temperature Rise**

Meaning: The internal temperature of the unit is too high. If the unit is being used in a normal temperature environment, this error may indicate that the fan is not functioning properly.

Remedy: Confirm that no fan warning has been output.

### **LoopRec Will Stop**

Meaning: The remaining available recording space is exceeded and partial save performed during loop recording. If recording continues, the available recording space becomes insufficient and recording is stopped.

Remedy: To continue recording, delete the partially saved file or the unnecessary unedited file to create space. Once the file is deleted and the warning display disappears, it is possible to continue loop recording.

### **Material Entry Full**

#### **Nearly Rec Stop**

#### **Rec Stopped**

#### **Not enough Space To Rec**

#### **Too Much Fragmentation**

#### **Temp. File Protected**

These are all special errors that may occur while editing in BVE mode. For details on these errors, refer to Section 5-5-9, "Editing-Related Error Messages" (page 5-9).

### **EF-30 Boot Fail**

#### **EF-30 ConfigFail**

#### **EF-31 ConfigFail**

These errors can occur only with the BKMA-560 or BKMA-561 installed, and indicates that the EF-30 board or EF-31 board has malfunctioned.

# Specifications

## General

Power supply voltage	100 to 240 V AC, 50/60 Hz
Current consumption	100 V : 5.5 A, 240 V : 2.3 A (with all options installed)
Operating temperature	+5°C to +40°C (41°F to 40°F)
Peak inrush current	(1)Power ON, current probe method: 70 A (240 V), 30 A (100 V) (2)Hot switching inrush current, measured in accordance with European standard EN55103-1: 60 A (230 V)
Storage temperature	-20°C to +60°C (-4°F to 140°F)
Humidity	20% to 90%
Mass	Approx. 50 kg (110 lb) (with all options installed)
Dimensions	424 × 265.6 × 631 mm (16.75 × 10.5 × 24.8 in.) (width/height/depth) (excluding projections)

## Operation

Recording/playback time	
SS mode	Maximum 6 h 20 min. (Bit rate: 30 Mbps, Audio: 16 bit/sample) Approx. 4 h 50 min (Bit rate: 40 Mbps, Audio: 20 bit/sample) Approx. 3 h 40 min (Bit rate: 50 Mbps, Audio: 20 bit/sample)
SD mode	Maximum 19 h 20 min. (Bit rate: 30 Mbps, Audio: 16 bit/sample) Approx. 14 h 40 min (Bit rate: 40 Mbps, Audio: 20 bit/sample) Approx. 11 h 20 min (Bit rate: 50 Mbps, Audio: 20 bit/sample)
Search speed	
SS mode	Shuttle mode: Stationary, ± 500 times normal speed Jog mode: -3/3 to 3/3 times normal speed Variable mode: -3/3 to 3/3 times normal speed
SD mode	Shuttle mode: Stationary, ± 500 times normal speed Jog mode: -2 to 2 times normal speed Variable mode: -2 to 2 times normal speed
Cue-up time	Minimum 0.5 s
Shortest time difference when sending	60 frames

## Port configuration

In SS mode:	1 input/1 output
In SD mode:	Select 3 input/1 output, 2 input/2 output, or 1 input/3 output on the menu

## Digital video system

### Codec

Compression	Complies with MPEG-2 4:2:2 Profile @ Main Level, GOP N=1
Bit rate	50 Mbps, 40 Mbps, 30 Mbps, selectable
Encoding samples	Y: 720/line B-Y/R-Y: 360/line
Encoded lines	525: 7-262, 270-525 625: 7-310, 320-623

### Digital video signal format

Sampling frequency	Y: 13.5 MHz R-Y/B-Y: 6.75 MHz
Quantization	8 bits/sample

### Digital inputs and outputs

Frequency range Y:	0.5 to 5.75 MHz +0.5/-0.75 dB
R-Y/B-Y:	0.5 to 2.75 MHz +0.5/-0.75 dB

### Analog composite input/output (with optional BKMA-513 installed)

Frequency range Y:	0 to 4.2 MHz +0.5/-0.5 (NTSC) 0 to 4.8 MHz +0.5/-1.0 (PAL)
--------------------	---

Signal-to-noise ratio	53 dB or more
Differential gain	2% or less
Differential phase	2° or less
Y/C delay	20 ns or less
K factor (2T pulse)	1% or less
Output SCH phase	Complies with RS-170A/CCIR R.624-3
LF nonlinearity	3.0% or less (includes quantization noise)

## Digital audio system

### Digital audio signal format (channels 1 to 4)

Sampling frequency	SDI: 48 kHz (synchronous with video) AES/EBU: 48 kHz (not synchronized with video)
Quantization	20 bits/sample, 16 bits/sample, selectable

Wow and flutter Unmeasurable  
Headroom 20 dB (or 18 dB, 16 dB, 14 dB, 12 dB, 15 dB, 9 dB, selectable)

### Analog input/output (with optional BKMA-513 installed)

A/D, D/A Quantization  
20 bits/sample

Frequency characteristics  
20 Hz to 20 kHz +0.5 dB/-1.0 dB (0 dB, 1 kHz)

Dynamic range 95 dB or more  
(1 kHz, emphasis on, 20 bits/sample)  
90 dB or more  
(1 kHz, emphasis on, 16 bits/sample)

Distortion 0.05% or less  
(1 kHz, emphasis on, +4 dBm, 600 Ω)

Cross-talk -85 dB or less  
(1 kHz, between channels, 20 bits/sample)  
-80 dB or less  
(1 kHz, between channels, 16 bits/sample)

Input reference level  
+4 dBm (+4/0/-3/-20 dBm, selectable)

Emphasis T1 = 50 μs, T2 = 15 μs  
(on/off selectable during recording)

### Processor adjustment ranges

#### Video system

Recording level ±3 dB/-∞ to +3 dB, selectable  
Chrominance level  
±3 dB/-∞ to +3 dB, selectable  
Setup/black level  
±30 IRE/±210 mV  
Hue/chrominance phase  
±30°  
System phase COARSE: ±30 μs (37 ns steps)  
FINE: 0 to +37 ns (0.14 ns steps)

#### Audio system

Input level -∞ to +12 dB  
Output level -∞ to +12 dB

---

### Input connectors

SDI INPUT BNC (2, active loop-through) ×3 ports  
Serial digital (270 Mbits/s)  
SMPTE 259M/CCIR 656-III

REF. VIDEO INPUT  
BNC (2, loop-through)  
black burst or composite sync  
0.3 Vp-p, 75 Ω (automatic termination)\*  
synchronized load

COMPOSITE VIDEO INPUT  
BNC (2, loop-through) ×2 ports  
1.0 Vp-p, 75 Ω (automatic termination)\*  
synchronized load  
(with optional BKMA-513 installed)

AUDIO INPUT (AES/EBU)  
CH1/2, CH3/4  
BNC (2) ×2 ports  
Complies with AES-3id-1995

ANALOG AUDIO INPUT  
XLR, 3-pin, male (4) ×2 ports  
LOW OFF: -60 dBu, high impedance,  
balanced  
HIGH OFF: +4 dBu, high impedance,  
balanced  
HIGH ON: +4 dBm, 600 Ω termination,  
balanced  
(with optional BKMA-570 (J)  
connected)

#### TIME CODE IN

BNC (1) ×2 ports  
0.5 to 18 Vp-p, 3.3 kΩ, unbalanced

#### TIME CODE IN (SYSTEM)

BNC (1)  
0.5 to 18 Vp-p, 3.3 kΩ, unbalanced

\* When the cable is not connected to the loop-through out connector, loop-through is automatically terminated (at 75 Ω). When the cable is connected, termination goes off.

---

### Output connectors

SDI OUTPUT BNC (2) ×3 ports  
Serial digital (270 Mbits/s)  
SMPTE 259M/CCIR 656-III

VIDEO MONITOR OUTPUT (SDI)  
BNC (1), with superimposed character  
information, SMPTE /CCIR 656-III

COMPOSITE VIDEO OUTPUT  
BNC (2) ×3 ports, character  
superimposition provided (B only)  
1.0 Vp-p, 75 Ω, negative  
synchronization  
(when the optional BKMA-513, sold  
separately, is installed)

VIDEO MONITOR OUTPUT (COMPOSITE)  
BNC (1), with superimposed character  
information  
1.0 Vp-p, 75 Ω, synchronized load

AUDIO OUTPUT(AES/EBU)  
CH1/2, CH3/4  
BNC (2) ×3 ports  
Complies with AES-3id-1995

ANALOG AUDIO OUTPUT  
CH1/2/3/4  
XLR, 3-pin, female (4) ×3 ports  
+4 dBm (with 600 Ω load), low  
impedance, balanced  
(with optional BKMA-570 (J)  
connected)

MONITOR OUTPUT (L/R)  
XLR, 3-pin, male (2)  
+4 dBm (with 600 Ω load), low  
impedance, balanced

TIME CODE OUTBNC (1) ×3 ports  
2.2 Vp-p (with 600 Ω load), low  
impedance, unbalanced

PHONES JM-60 stereo phones jack  
-∞ to -12 dBu (with 8 Ω load),  
unbalanced

---

## Remote connectors

REMOTE IN 1/2/3/4  
D-sub 9-pin, female ×4 (supports Sony's  
9-pin VTR protocol and DISK  
protocol)

REMOTE IN/OUT 1/2  
D-sub 9-pin, female ×2, for external  
VTR control (compatible with SONY  
9PIN VTR protocols)

REMOTE PARALLEL I/O  
D-sub 50-pin, female ×1, 24 inputs (5 V  
CMOS), 24 outputs (open collector)

Ethernet\* RJ45 ×1, 10 Base T

SPARE D-sub 9-pin, female ×1

Video CONTROL  
D-sub 25 pins, female ×1, video process  
control playback system (total of 3  
independent ports)

\* Ethernet is a registered trademark of the XEROX  
Corporation.

---

## Memory Card (sold separately)

Compatible memory cards: ATA flash card (PCMCIA 2.0  
(JEIDA 4.1), PCMCIA ATA 1.02, Type 2-compatible)  
Capacity: at least 8 MB

## Recommended products: "MemoryStick" + adapter

PC card adapter: MSAC-PC2N

"MemoryStick": MSA-8AN (8 MB)

---

## Supplied accessories

Operation Manual (1)

Installation Manual (1)

---

## Optional accessories

Control Panel BKMA-505

Control Panel Case Kit BKMA-506

AD/DA Converter Board BKMA-513

Video Effect Board BKMA-560

Video Effect Expansion Board BKMA-561

Analog Audio Expansion Unit BKMA-570

Rack Mounting Kit RMM-555

Editing Panel MAVE-F555

Dial Panel MAVE-D555

Editing Fader Panel BKNE-1011

In the interests of continuing product development,  
specification and external appearance are liable to change  
without prior notice.



The material contained in this manual consists of information that is the property of Sony Corporation and is intended solely for use by the purchasers of the equipment described in this manual.

Sony Corporation expressly prohibits the duplication of any portion of this manual or the use thereof for any purpose other than the operation or maintenance of the equipment described in this manual without the express written permission of Sony Corporation.

MAV-555SS  
(SY)  
3-206-660-02 (1)

**Sony Corporation**  
B & P Company  
<http://www.sony.net/>

Printed in Japan  
2002.06.13  
© 2001