

## INSTALL INSTRUCTIONS C-VS-1200-F250-1

### Vehicle Specific Console

**2008 FORD F-250, 350, 450 and 550 Pickup and Cab Chassis Trucks**

**TOOLS REQUIRED:**

Ratcheting wrench	Phillips Screwdriver
Metric/Standard Socket Set	T-20 Torx Driver bit
7/16" Wrench	7 mm Socket or Driver

**INSTALLATION HARDWARE:**

<u>QTY</u>	<u>DESCRIPTION</u>	<u>PART #</u>
1	1/4" X 1" Hex Bolt	GSM33002B
5	1/4" X 1/2" Carriage Bolt	GSM31999
6	1/4" Serrated Hex Flange Nut	GSM30023
1	1/4" Flat Washer	GSM31005B
3	#8 x 1/4" Flat Head Phillips Screw	GSM33178
1	Torx Screw Kit	C-HK-1

All other hardware is pre assembled on console or OEM hardware is reused.

**Always!**

- Read all instructions before installing any Havis-Shields Equipment Corp products.
- **Check for obstructions (Wire, brake lines, fuel tank, etc.) before drilling any holes!**
- Use only hardware provided with install kit.
- For product support, visit the Install Instructions Section of our website at <http://havis.com/Installation/Installation.html>, email [technicalsupport@havis.com](mailto:technicalsupport@havis.com) or call 1-800-524-9900 and ask for technical support.

**\*\*\*Crew Cab trucks will require the removal of the air conditioning / heat duct that runs on top of the transmission hump to rear seats. Installer will need to block off remaining duct opening. Screws, foam and duct tape can be used to close off duct. (Not included)\*\*\***

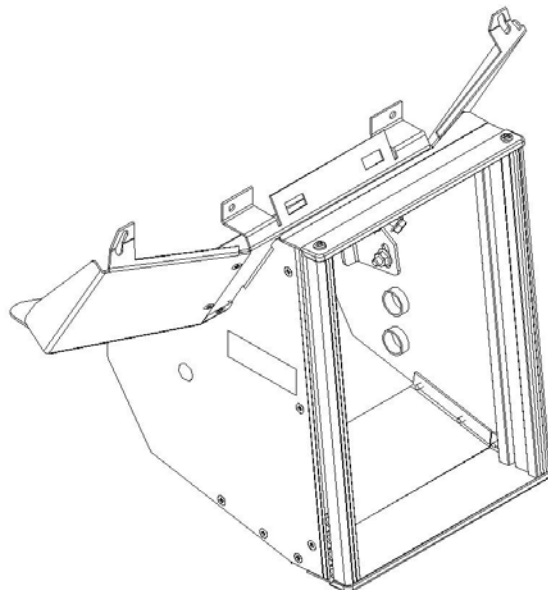



OEM Dashboard



Carefully remove the small dash panel that holds the lighter plug. Use 7mm socket and remove dash mount screw



Remove passenger side small panel. Use 7mm socket and remove dash mount screw



Carefully detach upper dash panel assembly from spring clips.



Unplug and remove complete upper dash panel. Note: Installation can be done without complete removal, but install is easier when removed.



Detach lower dash panel under steering column.



Use 7mm socket and remove three mount screws for lower center dash panel



Lower dash panels removed





Use 7mm socket and remove two center dash screws. Reuse these screws and attach lower console bracket.

Console shipped unassembled

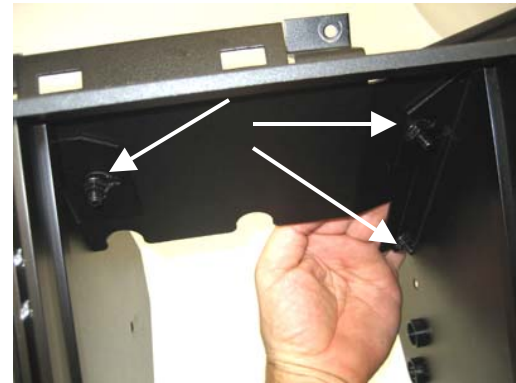

Assemble the two-piece dash adaptor panel with three (3) #8 x 1/4" Flat Head sheet metal screws.

Attach dash panel to console housing with three 1/4" x 1/2" carriage bolts and flange nuts. Do not tighten yet.

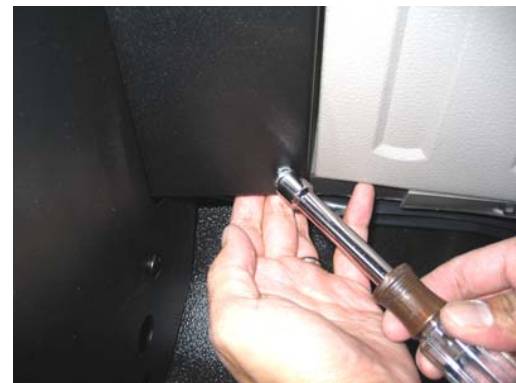

Attach console assembly with two OEM screws. Only attach two center screws at this time

Attach console housing to lower dash bracket with two 1/4" x 1/2" carriage bolts and flange nuts. Do not tighten yet.

Attach Dash panel at lower passenger side with 1/4" x 1" Hex bolt and flange nut. Reattach upper dash panel and driver side lower dash panel Use OEM dash screws



If truck has OEM center console, it will be a tight fit depending on control heads. This may require installation of lower faceplates into console prior to console housing mounting.



The cup holder on OEM console can be temporarily removed to create more space during installation. Remove two Phillips screws under armrest and unclip gray plastic front cap.



Wire and mount all control heads.  
 Note: Installation of lower faceplate screws may require a T-20 Torx bit in a ratchet wrench with a 1/4" hex socket.



Optional cup holder model C-CUP2-E-C mounted on side of console. Mount holes must be drilled in desired location.  
 Optional Mic Clip brackets model C-MCB mount to side accessory nuts.