

HOLLYWOOD RACKS

Pour instructions en Français, continuer aux pages 6 et 7.

Sport Rider Instruction Manual Model HR1000 – 2 Bike Hitch Rack *with ratcheting hooks*

- Not to be used on any trailer, fifth wheel or vehicle being towed by another vehicle
- Weight Limit 45lbs/20 kg per bike
- 2 bike maximum capacity
- Optional locking kits available



ID#	Description	Qty
A	MAIN RACK ASSY	1
B	SHORT FRAME HOOK	1
C	LONG FRAME HOOK	1
D	RECEIVER TUBE & SPACER	1
E	LEFT SIDE WHEEL TRAY	2
F	RIGHT SIDE WHEEL TRAY	2
G	REC. TUBE STOP BOLTS	2
H	LOWER BRACKET	1
I	8MM BOLTS	4
J	FLAT WASHERS	4
K	5MM HEX KEY	1
L	LOCK WASHERS	2
M	½-13 THREADED HITCH PIN	1
N	HITCH PIN CLIP	1
P	WHEEL TUBE STOP SCREWS	2

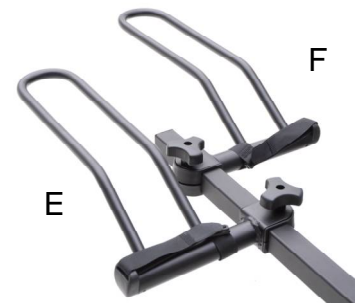
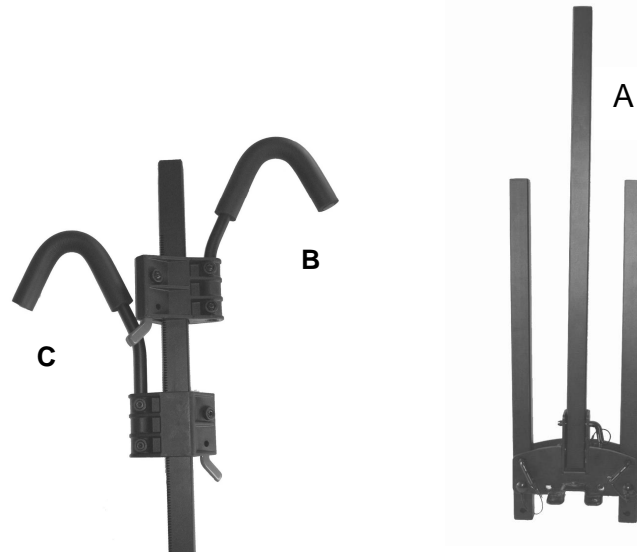
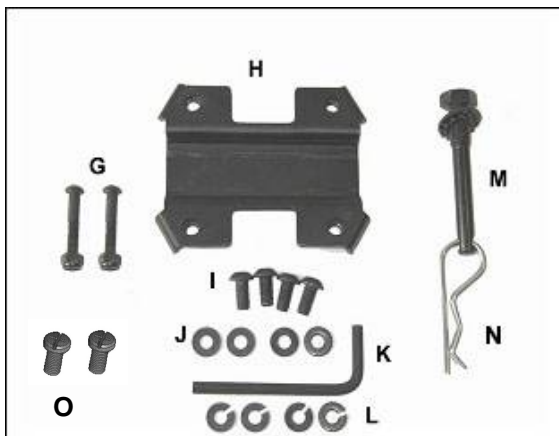
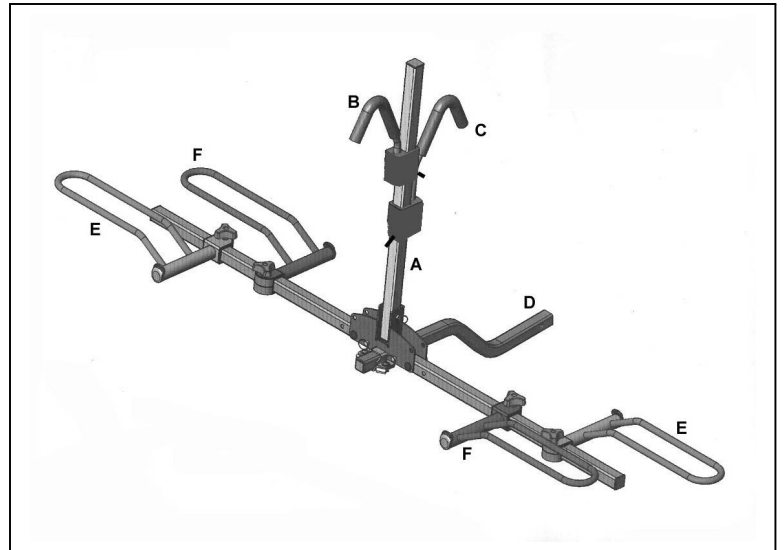

Assembly & Installation Procedure:

Step 1: Locate holes on main rack assembly, bracket and hardware (Fig. 1)

Step 2: Loosely assemble bracket to main rack as shown in Fig. 2 & 3. Bolts (I) inserts through lock washer (L), then flat washer (J), then top plate and into bottom plate Do Not tighten!

Step 3: Slide main rack assembly onto Receiver tube as shown in Fig. 4 & 5. Adjust position so that is 3 or 4 inches between the end of the rack and end of the receiver tube. Tighten using hex wrench provided or equivalent. *Note: Final position of vertical portion of the rack can be re-adjusted after you have installed the rack on your vehicle*

Step 4: Insert "stop bolts" (G) through hole in receiver tube as indicated. See Fig. 6.

Fig. 1

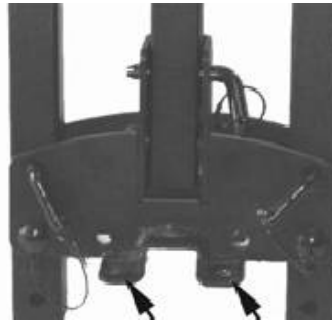

Fig. 2



Fig. 3



Fig. 4

Fig. 5

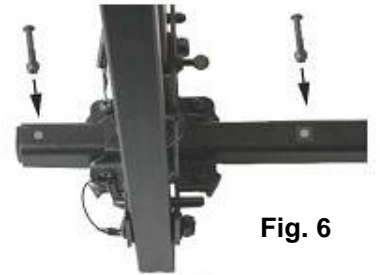

Fig. 6

Step 5a: Install Wheel holders:

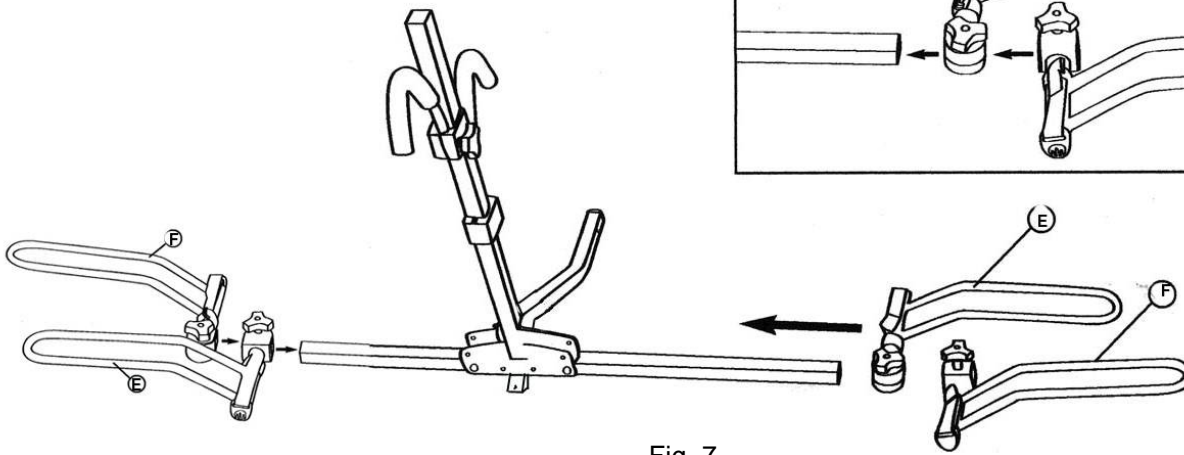
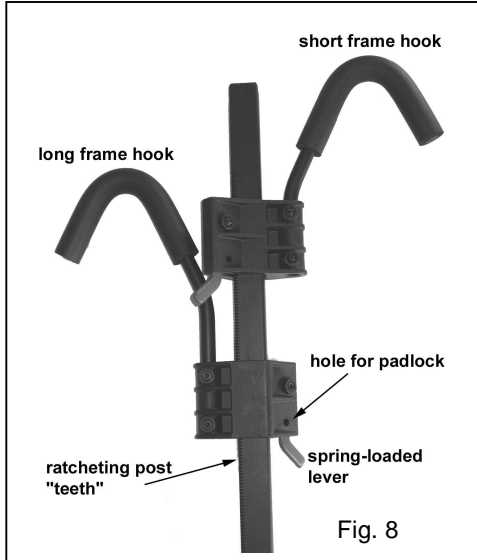

Fig. 7

Step 6: Install frame hooks:

Slide long frame hook down vertical post facing vehicle. Then slide short frame hook onto post, facing away from vehicle. You should hear the spring loaded lever engaging the teeth on the post as shown in fig. 8.



Step 6A: Installing into a 1 1/4" trailer

Note: The receiver tube comes ready for installation into a 2" hitch. If you have a 1 1/4" hitch, use the provided hex wrench to remove the plastic spacer as shown in Fig. 9. Place lock washer and flat washer onto hitch pin bolt as indicated. Insert the receiver tube into the hitch. Align the holes, insert the hitch pin bolt and tighten securely using a 3/4" wrench.

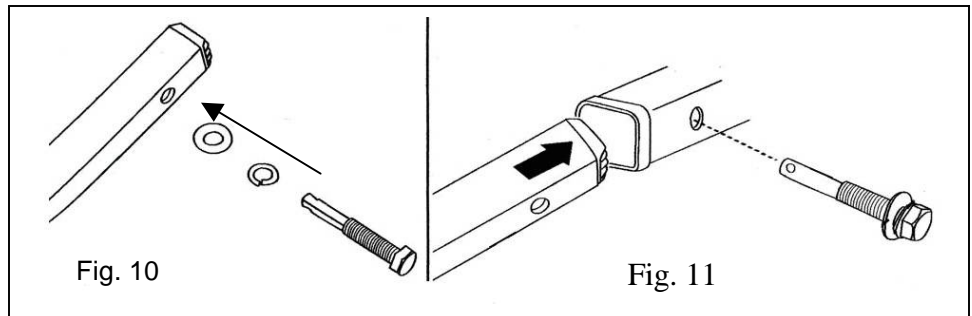
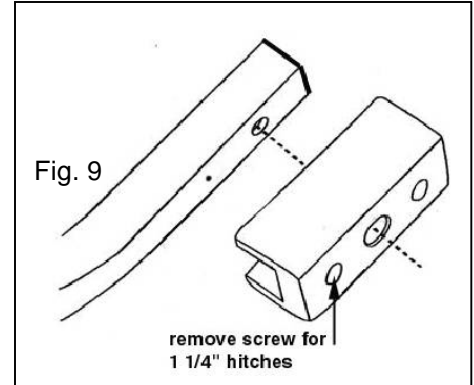

Step 6 B: Installing into a 2" trailer hitch

Place lock washer and flat washer onto hitch pin bolt as indicated. Insert the receiver tube into the hitch. Align the holes, insert the hitch pin bolt and tighten securely using a 3/4" wrench.

Important! When inserting the hitch pin bolt, the bolt should pass through the receiver tube first then through the plastic spacer.

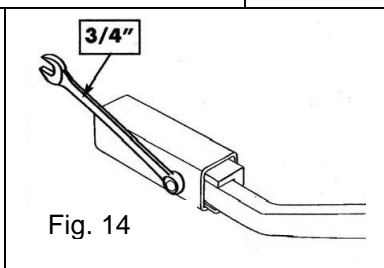
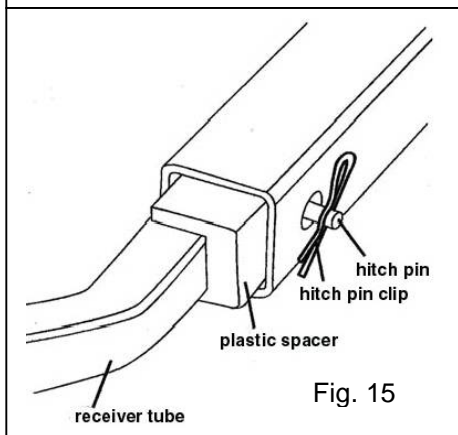
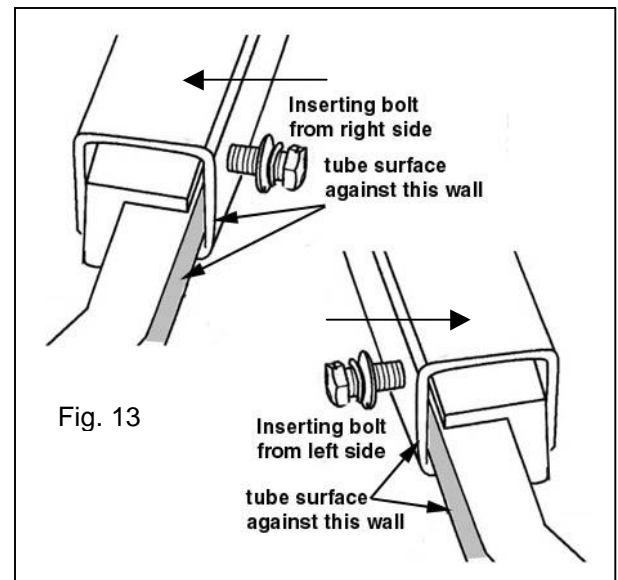
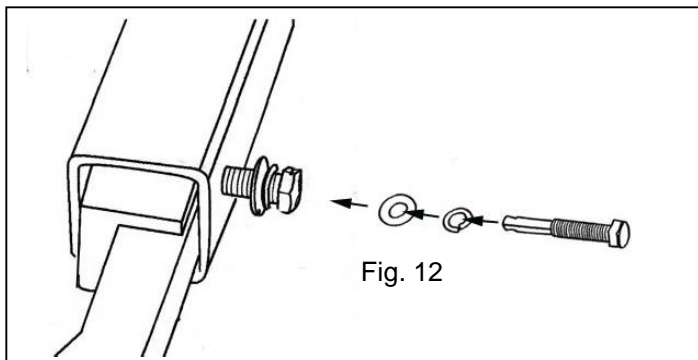

Install Hitch pin clip after tightening bolt

Folding Down Vertical Post

For easy access to the cargo area, the vertical post can be folded down. To fold down vertical post, rotate and remove the side-retaining pin as shown in Fig. 16a-16d. Be sure to re-tighten the thumbscrew after replacing pin.

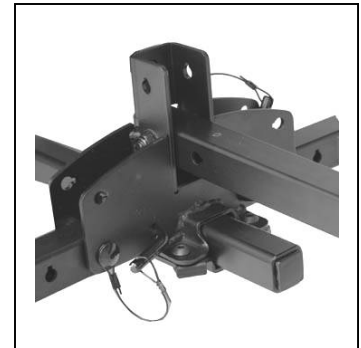
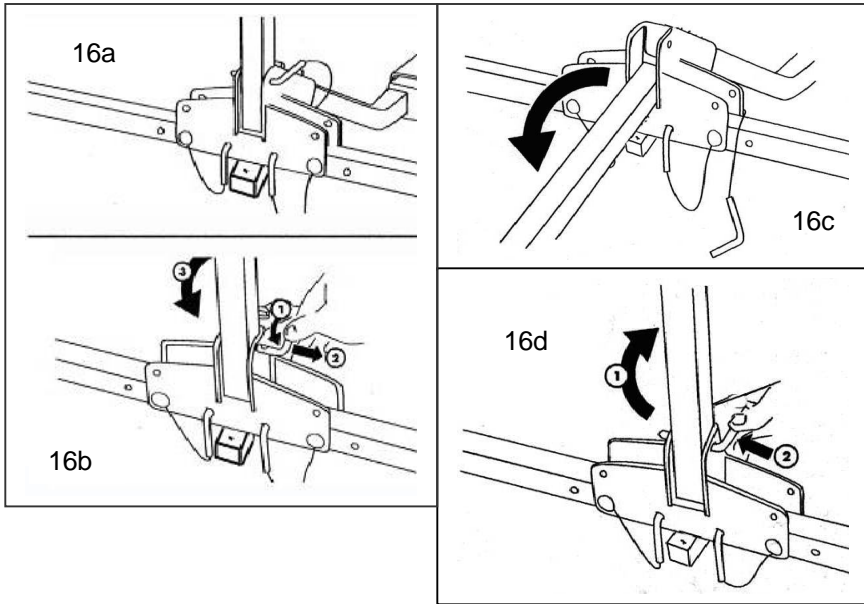

Folding Up the Wheel Holders

To fold up the wheel holders, rotate and remove the front retaining pins. Then rotate the tube up and re-install the pins. See Fig. 17a & 17b

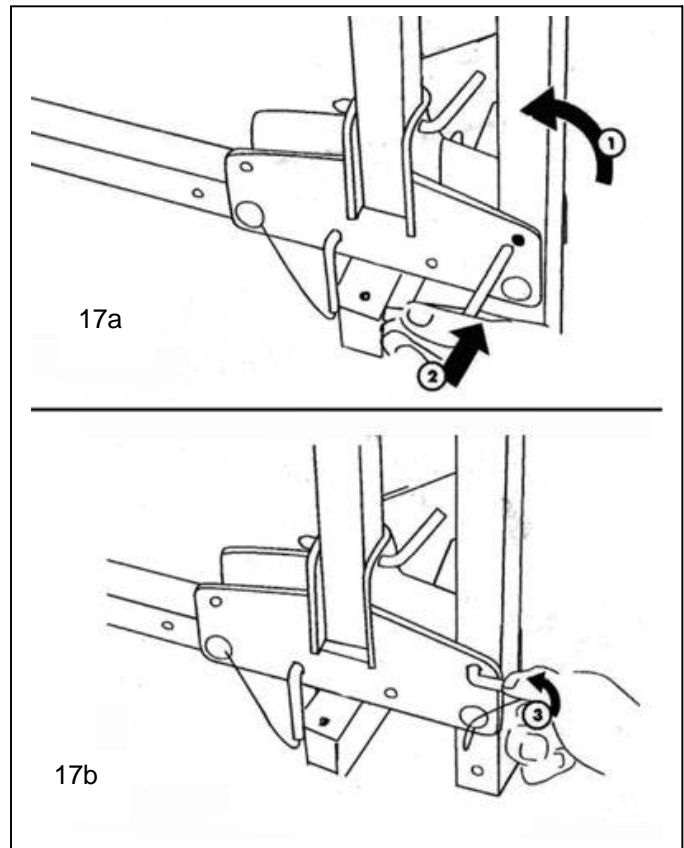

Installing Bikes on the Rack

Pre-position the wheel trays to fit the bike's wheel base (center to center distance between the wheel axels) such that they are directly beneath each wheel. To adjust the wheel trays, loosen the knobs and slide along the wheel holder support tube. Tighten knobs securely.

To fit the first bike (closest to the vehicle) more easily, the vertical post may be tilted down (away from vehicle). To do this, simply remove the side retaining pin per. Note: Never fold down main tube with bike(s) mounted. Place the first bike in the wheel holders, and then rotate the vertical post up per Fig 16d. Handlebars for the first bike should be on the driver's side of the vehicle. If carrying two bikes, always load the smaller bike first (position the smaller bike between the vehicle and vertical post)

Be sure that the hooks are well supported on the bike's frame. Push hook firmly down onto bike frame as shown in Fig 18d. Try pulling up on the hook to be sure the teeth and lever are properly engaged. Use the Velcro strap on the wheel holder as the final step of installing the bikes on the rack, per Fig. 18e.

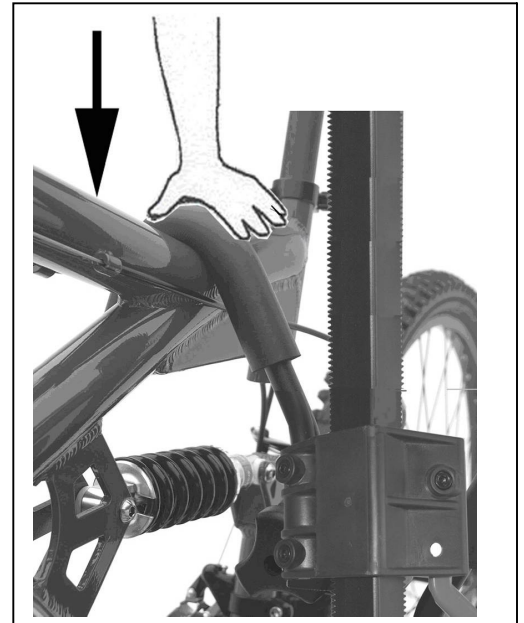
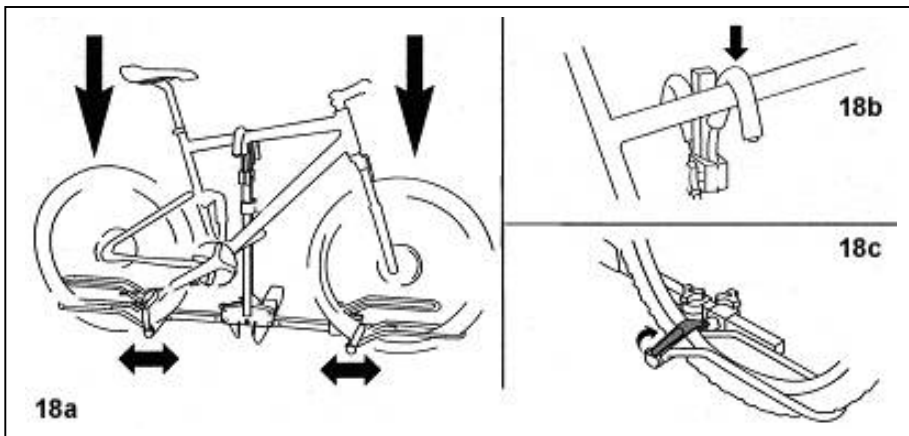

Tips for carrying woman's bikes and bikes with slanted top tubes

Adjust the wheel trays so that the hook will rest in the bike frame's top tube and seat tube, as shown in Fig. 19a and 19b.

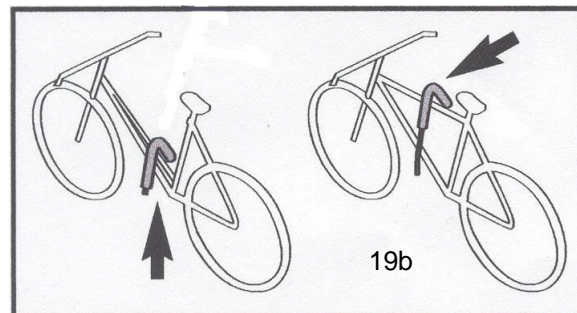

To release the frame hook, depress the Lever and pull the hook up.

Tip: you may have to push the hook down a bit while holding in the lever to release it.

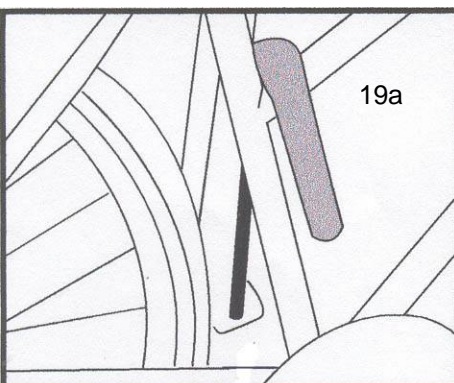

INSTRUCTIONS CONTINUED ON BACK PAGE

Hollywood Sport Rider.

Modele HR1000 Porte-vélo pour atelage remorque pour 2 vélos.

ne pas utiliser ce produit sur une remorque ou un véhicule qui est remorqué.
Limite de poids par vélo de 45lbs ou 20 kgs
Capacité maximum 2 vélos

<u>Ref</u>	<u>Description des pièces</u>	<u>Quantité</u>
A	Cadre principal	1
B	Crochet court	1
C	Crochet long	1
D	Tube pour l'attelage remorque	1
E	Support roue gauche	2
F	Support roue droite	2
G	Boulon pour extrémité de D	1
H	Attache inférieure	1
I	Boulons de 8mm	4
J	Rondelles	4
K	Clefs de 5mm	1
L	Rondelles de sécurité	2
M	½-13 Cheville anti-jeu	1
N	Agrafe pour cheville anti-jeu	1
O	Boulons pour tube de support roués	2

Assemblage et procédure d'installation

1. Trouver les trous sur le cadre principal A, attache inférieure H et boulons et rondelles I et J (Fig 1 et 2) Attacher légèrement A et H avec I et J comme sur Fig.3. Ne Pas serrer!
2. Glisser le Tube pour l'attelage remorque D entre A et H comme sur la Fig 5. Ajuster la position pour que la distance entre l'extrémité de D et l'extrémité de l'ensemble A et H soit de 3 ou 4 pouces. Serrer fermement avec la clef K ou équivalent. *Note: la position verticale de l'ensemble peut être ré-ajusté après avoir installé le Sport Rider sur le véhicule.*
3. Insérer le boulon G à l'extrémité de D (Fig 6)
4. Installation des crochets. Glisser le long crochet C le long du mât central, crochet court vers le véhicule. Ensuite glisser le crochet court B le long du mât central, crochet vers l'extérieur ou l'arrière. Vous devriez entendre les cliquements du levier avec ressort s'engageant sur le mât comme sur Fig.8
- 6A Installation du tube de l'attelage pour attelage de 1-1/4"
Note: La pièce D est prête pour l'attelage de 2". Si vous avez l'attelage pour 1-1/4", utiliser la clef K pour enlever la pièce en plastique comme sur la Fig 9. Placer la rondelle de blocage et la rondelle plate sur la cheville anti-jeu (Fig 10). Insérer le Porte-vélo dans l'attelage. Aligner les trous et insérer la cheville anti-jeu et serrer fermement avec une clef de ¾" (Fig 11).
- 6B Installation du tube de l'attelage pour attelage de 2".
Placer la rondelle de blocage et la rondelle plate sur la cheville anti-jeu (Fig 12). Insérer le Porte-vélo dans l'attelage. Aligner les trous et insérer la cheville anti-jeu et serrer fermement avec une clef de ¾" (Fig 14).
Important! La cheville doit passer en premier à travers le tube métallique de l'attelage avant la pièce en plastique (Fig 13)

Inclinaison du mât central.

For un accès facile a la porte arrière, le mât central s'incline en tournant et en enlevant la broche comme sur Fig 16a-16d. Assurez vous de reserrer la vis après avoir redresser le mât.

Rangement des support de roues

Pour ranger les supports de roues, tounez et enlevez les broches de devant. Fig 17a & 17b.

Installation des vélos sur le Porte-vélo

Pré-positionner les supports de roues E et F à la distance du centre de chaque roue de chaque vélo. Pour ajuster les supports de roues, deserrer les molettes, faire glisser les supports de roues le long des tubes pour les supports de roues. Reserrer les molettes fermement (Fig 18a)

Pour monter le premier vélo vers le véhicule, le mât central peut être incliné Fig 16a-16d. Le guidon du premier vélo devrait être du côté du conducteur. Si vous portez 2 vélos, toujours charger le vélo le plus petit d'abord (entre le véhicule et le mât central).

Baisser les crochets sur le cadre fermement comme sur Fig 18d. Essayer de relever le crochet pour d'assurrer que les dents du levier soient bien engages. Toujours utiliser les sangles en Velcro pour les roues du vélo.

Répèter pour le deuxième vélo (côté extérieur du mât).

Important: Pour les vélos femmes/ mixte ou avec cadre avec tube central incliné.

Ajuster les supports de roues de façon à ce que le crochet soit à l'intersection sur le cadre du tube de selle et du tube central incliné (Fig 19a)

Etape finale: Installer les boulons pour les supports roues: Après avoir monte les vélos sur le Sport Rider, les boulons P doivent être intallés a l'extrémité et au dessous des tubes de support de roues Fig.20a et 20b

Vérifier Les choses suivantes avant de partir.

Molettes bien serrées pour les supports de roues et les crochets

Toutes les broches soient proprement inserrées et securisées.

Les sangles pour les roues soient bien attachées.

Cheville anti-jeu et attache pour cheville soient bien installées

Conduire doucement sur chaussée en mauvais état ou chemin de terre.

Important:

Le fabricant de ce produit n'est pas responsable des dommages causés par le mauvais usage de ce produit. C'est la responsabilité de l'utilisateur de s'assurer que le porte vélo est monté proprement sur le véhicule et que les vélos soient proprement chargés sur le porte vélo comme decrit dans ces instructions d'installation.

Final Step: Install wheel tube stop screws: After you have installed the bikes on the rack and are comfortable with the positions of the wheel holders, the stop screws can be installed. Locate items P from hardware bag. Thread them into the hole located on the bottom of wheel tubes (Fig. 20), and tighten with a flat edge screwdriver. The screws are removable.

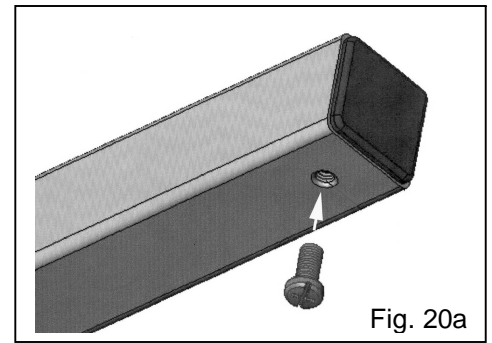
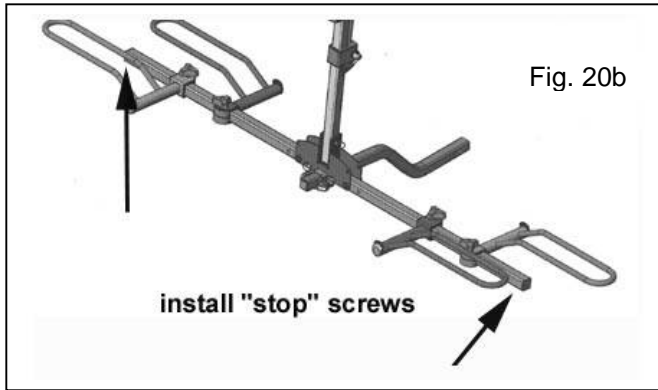

Double check before driving off:

- Knobs are tight on all four wheel trays and
- Frame hooks are pushed all the way down
- All three retaining pins are properly inserted and secure
- Wheel straps are fastened
- Hitch pin is secure and hitch pin clip is installed
- Drive slowly on bumpy or dirt roads

**Optional accessories
for your Sport Rider**



Locking Threaded
hitch pin with
security cable
part no. LHPTC



Locking threaded
hitch pin
part no. LHPT

Limited Lifetime Warranty (effective January 1, 2008):

Hollywood Racks will warrant its car racks and accessories during the time that an original retail purchaser owns the product subject to the exclusions and limitations of this warranty. Hollywood Racks will remedy defects in materials and workmanship by repairing or replacing (at its option) a defective part or the complete rack without charge for labor or parts. Hollywood Racks may elect (at its option) to issue a refund equal to the purchase price paid for the product.

This warranty does not cover problems caused by normal wear and tear including (but not limited to) weather, scratches, dents, rust, accidents, unlawful vehicle operation, misuse, abuse, neglect, theft, unauthorized modifications, or unauthorized repair. No warranty is given for defects resulting in incorrect assembly, incorrect installation onto the vehicle, installation on a "no fit" vehicle, incorrect attachment of bicycles onto the rack, or overloading of the rack's weight restrictions. This warranty terminates if the original retail purchaser transfers the product to any other person. If a product is believed to be defective, the original retail purchaser should contact either the original retailer or Hollywood Racks directly at 800-747-4085 or at info@hollywoodracks.com

Disclaimer of Liability: Repair or replacement of a defective product or the issuance of a refund or credit (as determined by Hollywood Racks) is a purchaser's exclusive remedy under this warranty. Damage to a purchaser's vehicle, cargo, bicycles and or to any other person is excluded. This warranty is expressly made in lieu of any and all other express warranties, whether oral or written.

Hollywood Racks shall not be liable for any direct, indirect, consequential, incidental, special, punitive or any other damages in connection with the purchase, use or handling of this product. Some states do not allow the exclusion or limitation of consequential or incidental damages and the above limitation may not apply to you. This warranty gives you specific legal rights and you have other rights, which vary from state to state.

Hollywood Racks
Quality bicycle racks since 1973
 12812 S. Spring St. Los Angeles, CA 90061
 Tel (310) 516-8600 (800) 747-4085 FAX (310)516-8955
www.hollywoodracks.com email: info@hollywoodracks.com
Customer Service Hours: M-F 8:00AM to 3:00 PM PST
Made in Taiwan *102908 rev. E*