



PRO-MAX[®] SMOOTH TWO-SIDED CHROME GRILL

Model GR14C

Features/Benefits:

- ★ Expand your menu with Star's Pro-Max two sided grills. Prepare chicken, quesadillas, sandwiches and many other menu items quickly and easily while maximizing space.
- ★ Grill features a hard chrome surface to provide superior cooking performance and even heat distribution. Highly polished chrome surface reflects heat inward reducing radiant heat, lowers energy costs and keeps the kitchen cooler. The non-porous surface eliminates food taste transfer and can be cleaned easily, reducing labor costs.
- ★ A heavy - duty counter balance hinge system provides safe and effortless operation of top platen.
- ★ Thermostat is rated from 250°F(79°C) to 550°F (302°C).
- ★ Ergonomically control panel provides easy access to controls and grease drawer.
- ★ Spacious grilling height accommodates product up to three inches with three to four pounds of pressure for proper cooking between platens.
- ★ Painted aluminum platen handle provides heavy-duty, safe operation of top platen.
- ★ The bottom platen has a patented splash guard to help keep products and grease in their place.
- ★ Front grease trough and drawer for easy cleaning.

Applications:

Star's two-sided grill can prepare chicken, sandwiches, quesadillas and many other menu items quickly and easily. The chrome surface retains more energy to provide maximum cooking performance.

Quality Construction:

The rugged body is constructed of 18 gauge stainless steel. The grill is supplied with grease trough and stainless steel grease drawer. The counter balance mechanism is constructed from hardened aluminum. The 6 foot lead-in cord has a special covering that is resistant to water and oil and the wires are protected by metallic braiding. Cord comes complete with plug (see typical specifications).

Warranty:

Two-sided grill is covered by Star's one year parts and labor warranty.



Model GR14C





**PRO-MAX® SMOOTH
TWO-SIDED CHROME GRILL**
Model GR14C

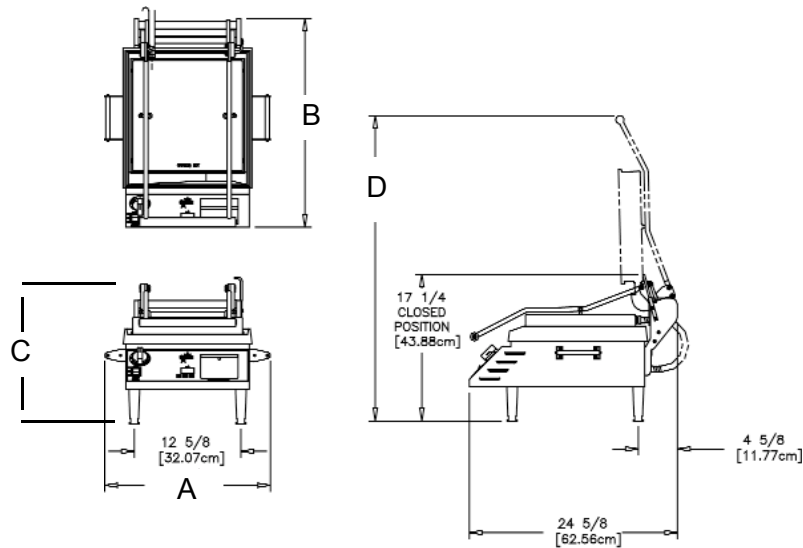

14" SANDWICH GRILL
WITH 4" LEGS

Model and Specifications

Model No.	Grid Surface	(A) Width Inches (cm)	(B) Depth Inches (cm)	(C) Closed Inches (cm)	(D) Open Inches (cm)	Voltage	Wattage	Amps	NEMA Plug	Approximate Weight	
										Shipping lbs. (kg)	Installed lbs. (kg)
GR14C	Chrome	16 (40.6)	23-1/8 (58.7)	17-1/4 (43.8)	34-5/8 (88.0)	208/240V	2700/3600	13/15	6-20P	101 (45.9)	90 (40.9)

Typical Specifications

Two-sided grill is constructed with a stainless steel body and smooth chrome plated plates. Designed with electric controls for precise temperature control and digital timer for select menu items. A counter balance hinge mechanism provides easy operation of both top platens. Grilling height between platens is up to 3" with counter balance system providing 3-4 pounds of pressure to the cooking product placed on bottom platen. Metal sheathed tubular elements and adjustable non-skid feet are standard. Unit has six foot power cord with NEMA plug. Units approved with UL, UL Sanitation or UL Canada Standards. Printed in the U.S.A.

Due to periodic changes in designs, methods, procedures, policies and regulations, the specifications contained in this sheet are subject to change without notice. While Star Manufacturing exercises good faith efforts to provide information that is accurate, we are not responsible for errors or omissions in information provided or conclusions reached as a result of using the specifications. By using the information provided, the user assumes all risks in connection with such use.