



# **3Com Family Switch 7750 Installation Guide**

**3C16896 8-slot AC Chassis  
3C16897 8-slot DC Chassis  
3C16895 7-slot Chassis  
3C16894 4-slot Chassis  
and associated modules**

**<http://www.3com.com/>**

Part No. 10016428-AB  
Published December 2007

**3Com Corporation**  
**350 Campus Drive**  
**Marlborough, MA**  
**01752-3064**

Copyright © 2005, 2007 3Com Corporation. All rights reserved. No part of this documentation may be reproduced in any form or by any means or used to make any derivative work (such as translation, transformation, or adaptation) without written permission from 3Com Corporation.

3Com Corporation reserves the right to revise this documentation and to make changes in content from time to time without obligation on the part of 3Com Corporation to provide notification of such revision or change.

3Com Corporation provides this documentation without warranty, term, or condition of any kind, either implied or expressed, including, but not limited to, the implied warranties, terms or conditions of merchantability, satisfactory quality, and fitness for a particular purpose. 3Com may make improvements or changes in the product(s) and/or the program(s) described in this documentation at any time.

If there is any software on removable media described in this documentation, it is furnished under a license agreement included with the product as a separate document, in the hard copy documentation, or on the removable media in a directory file named LICENSE.TXT or !LICENSE.TXT. If you are unable to locate a copy, please contact 3Com and a copy will be provided to you.

#### **UNITED STATES GOVERNMENT LEGEND**

*If you are a United States government agency, then this documentation and the software described herein are provided to you subject to the following:*

All technical data and computer software are commercial in nature and developed solely at private expense. Software is delivered as "Commercial Computer Software" as defined in DFARS 252.227-7014 (June 1995) or as a "commercial item" as defined in FAR 2.101(a) and as such is provided with only such rights as are provided in 3Com's standard commercial license for the Software. Technical data is provided with limited rights only as provided in DFAR 252.227-7015 (Nov 1995) or FAR 52.227-14 (June 1987), whichever is applicable. You agree not to remove or deface any portion of any legend provided on any licensed program or documentation contained in, or delivered to you in conjunction with, this User Guide.

Unless otherwise indicated, 3Com registered trademarks are registered in the United States and may or may not be registered in other countries.

3Com and the 3Com logo are registered trademarks of 3Com Corporation.

Intel and Pentium are registered trademarks of Intel Corporation. Microsoft, MS-DOS, Windows, and Windows NT are registered trademarks of Microsoft Corporation. UNIX is a registered trademark in the United States and other countries, licensed exclusively through X/Open Company, Ltd.

IEEE and 802 are registered trademarks of the Institute of Electrical and Electronics Engineers, Inc.

All other company and product names may be trademarks of the respective companies with which they are associated.

#### **ENVIRONMENTAL STATEMENT**

It is the policy of 3Com Corporation to be environmentally-friendly in all operations. To uphold our policy, we are committed to:

Establishing environmental performance standards that comply with national legislation and regulations.

Conserving energy, materials and natural resources in all operations.

Reducing the waste generated by all operations. Ensuring that all waste conforms to recognized environmental standards. Maximizing the recyclable and reusable content of all products.

Ensuring that all products can be recycled, reused and disposed of safely.

Ensuring that all products are labelled according to recognized environmental standards.

Improving our environmental record on a continual basis.

#### **End of Life Statement**

3Com processes allow for the recovery, reclamation and safe disposal of all end-of-life electronic components.

#### **Regulated Materials Statement**

3Com products do not contain any hazardous or ozone-depleting material.

# CONTENTS

## ABOUT THIS GUIDE

Conventions	5
Related Documentation	5

## SWITCH 7750 COMPONENTS

Switch Chassis	7
Switch Backplane	7
Fabric Module	8
Fabric 32 Submodules	12
I/O Modules	14
Power Module	33
Power Distribution	33
External PoE Power System	33
Fan Assembly	34
Switch 7750 Specifications	35

## INSTALLING THE SWITCH 7750

Preparing to Install	37
General Site Requirements	38
Installation Checklist	39
Installing the Chassis	40
Installing the Cabling Rack	40
Installing a Module	41
Installing a Submodule	41
Connecting the Ground Wire	42
Connecting and Configuring Power	42
Installing the Fan Assembly	45
Installing Cables	45
Installing Cabling	47
Post-installation Checklist	48

## CONFIGURING THE SWITCH 7750

Configuring the Switch 7750 and a Local Terminal	49
Setting Terminal Parameters	49
Booting the Switch 7750	52

## **MAINTAINING SOFTWARE**

- Upgrading Software 55
- Lost Passwords 63
- Using the BOOT Menu 63

## **TROUBLESHOOTING**

- Troubleshooting the Configuration 67
- Troubleshooting Power 67
- Troubleshooting the Fan 68
- Troubleshooting the Modules 68

## **MAINTAINING HARDWARE**

- Replacing a Power Module 69
- Replacing a Power Supply 70
- Replacing I/O Modules 71
- Replacing the Fan Assembly 71

## **OBTAINING SUPPORT FOR YOUR SWITCH**

- Register Your Product to Gain Service Benefits 73
- Purchase Value-Added Services 73
- Troubleshoot Online 73
- Access Software Downloads 73
- Contact Us 74
- Telephone Technical Support and Repair 74

## **SWITCH 7750 CABLES**

- Console Cable 77
- AUX Cable 77
- Electrical Port Connector 78
- Optical Fiber Cable Connectors 79

# ABOUT THIS GUIDE

This guide describes the 3Com® Switch 7750 and how to install hardware, configure and boot software, and maintain software and hardware. This guide also provides troubleshooting and support information for your switch.

This guide is intended for qualified Service personnel who are responsible for configuring, using, and managing the switches. It assumes a working knowledge of local area network (LAN) operations and familiarity with communication protocols that are used to interconnect LANs.



Always download the Release Notes for your product from the 3Com World Wide Web site and check for the latest updates to software and product documentation at <http://www.3com.com>.

---

## Conventions

Table 1 lists icon conventions that are used throughout this guide.

**Table 1** Notice Icons

Icon	Notice Type	Description
	Information note	Information that describes important features or instructions.
	Caution	Information that alerts you to potential loss of data or potential damage to an application, system, or device.
	Warning	Information that alerts you to potential personal injury.

---

## Related Documentation

The following manuals offer additional information necessary for managing your Switch 7750:

- *Switch 7750 Command Reference Guide* — Provides detailed descriptions of command line interface (CLI) commands, that you require to manage your Switch 7750.
- *Switch 7750 Configuration Guide*— Describes how to configure your Switch 7750 using the supported protocols and CLI commands.
- *Switch 7750 Release Notes* — Contains the latest information about your product. If information in this guide differs from information in the release notes, use the information in the *Release Notes*.

These documents are available in Adobe Acrobat Reader Portable Document Format (PDF) on the 3Com World Wide Web site at <http://www.3com.com/>.



# 1

## SWITCH 7750 COMPONENTS

The chapter describes the following Switch 7750 components:

- Switch Chassis
- Switch Backplane
- Fabric Module
- Fabric 32 Submodules
- I/O Modules
- Power Module
- Power Distribution
- External PoE Power System
- Fan Assembly
- Switch 7750 Specifications

---

### Switch Chassis

The Switch 7750 is available with a 4-slot, 7-slot, or 8-slot chassis. Table 2 lists the hardware features of each model.

**Table 2** Hardware Features of the Switch 7750 Models

	<b>4-Slot Chassis 3C16894</b>	<b>7-Slot Chassis 3C16895</b>	<b>8-Slot Chassis AC 3C16896 DC 3C16897</b>
Fabric slots	1	1	2
I/O module slots	3	6	6
Fan slot	1	1	2
AC/DC Power module slots	2	3	3

---

### Switch Backplane

The Switch 7750 backplane is part of the integrated chassis and delivers high-speed data transfer between the Fabric and I/O modules. The backplane bandwidth capacity is 96 Gbps.

The backplane supports the following functions:

- Interconnection of signals between modules
- Provides communication channels
- Hot swapping for modules
- Automatic recognition of slots
- Distribution of power and management of the power supply for the system

## Fabric Module

There are three Fabric modules for the Switch 7750:

- Fabric 64 (3C16857 or 3C16857R)
- Fabric 32 (3C16872)
- PoE Fabric 96 (3C16886)

The Fabric 64 and Fabric 32 are not interchangeable. You can install the Fabric 32 only in a 4-slot chassis. You can install the Fabric 64 only in the 7-slot or 8-slot chassis. You can install the PoE Fabric 96 in all three chassis.

The Fabric module is the core of Switch 7750 system. It has the following functions:

- Connects the I/O modules through the backplane and forwards Layer 2 and Layer 3 data
- Manages and calculates routing
- Performs the switch’s software upgrade and system reset functions
- Monitors system power and the fan frame

Figure 1 illustrates the front panel of the PoE Fabric 96.

**Figure 1** PoE Fabric 96

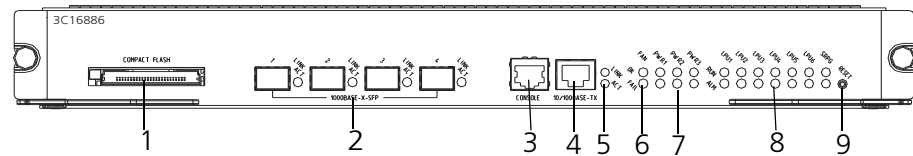

- 1 Compact Flash port
- 2 1000BASE-X-SFP ports
- 3 Console port
- 4 Ethernet port
- 5 Ethernet port LEDs
- 6 Fan LEDs
- 7 Power LEDs
- 8 I/O module LEDs
- 9 Reset button

Figure 2 illustrates the front panel of the Fabric 64.

**Figure 2** Fabric 64

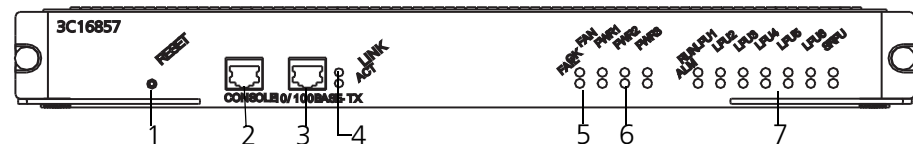

- 1 Reset button
- 2 Console port
- 3 Ethernet port
- 4 Ethernet port LEDs



- 5 Fan LEDs
- 6 Power module LEDs
- 7 I/O module LEDs

Figure 3 illustrates the front panel of the Fabric 32.

**Figure 3** Fabric 32

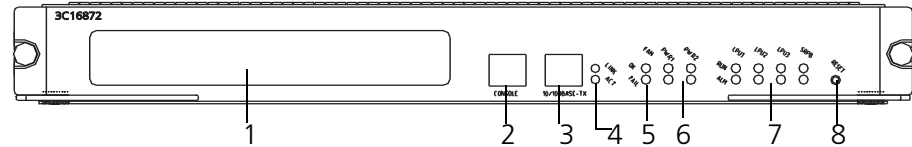

- 1 Submodule slot
- 2 Console port
- 3 Ethernet port
- 4 Ethernet port LEDs
- 5 Fan LEDs
- 6 Power LEDs
- 7 I/O module LEDs
- 8 Reset button

Table 3 lists Fabric specifications.

**Table 3** Fabric Specifications

Item	PoE Fabric 96 (3C16886)	Fabric 64 (3C16857 or 3C16857R)	Fabric 32 (3C16872)
Bandwidth	96 Gbps	64 Gbps	32 Gbps
CPU	MPC8245	MPC8260 200 Mhz	
BootROM	512 KB	1 MB	
SDRAM	256 M	256 MB	
Flash	32 MB	16 MB	
Submodule slot			1
Dimensions (L x W)	366.7 mm x 340 mm (14.5 x 13.5 in)		
External ports	<p>One console port that supports local and remote dial-up configuration management of the switch.</p> <p>One 10BASE-T/100BASE-TX port for upgrade and network management</p> <p>One Compact Flash port for storing log and host version and for online software upgrades</p> <p>Four 1000BASE-X-SFP ports</p>		
Maximum power consumption	80 W	80 W	70 W (with submodule)

**Submodule Slot** The submodule slot in the Fabric 32 offers extended Ethernet capacity using the following submodules:

- 4-port 1000BASE-X-GBIC submodule
- 4-port 10/100/1000BASE-T submodule

For more information on these submodules, see “Fabric 32 Submodules” on page 12.

**Fixed Ports** The Switch 7750 Fabric modules provide the following fixed ports:

- Compact Flash (CF) Port
- 1000BASE-X-SFP (PoE Fabric 96 only)
- Console Port
- Ethernet Port

**Compact Flash (CF) Port**

The Fabric module provides a CF port to accommodate a standard CF card, where you can save logging information, host version information, alarming and other diagnostic information. You can also use the CF port to upgrade software online.

**1000BASE-X-SFP Ports**

The PoE Fabric 96 provides four 1000 Mbps full-duplex SFP ports. Table 4 describes the SFP cables for these ports.

**Table 4** Cables for 1000BASE-T-SFP Modules

SFP Module	Central Wavelength	Connector	Matching Cable	Maximum transmission distance
1000BASE-SX-SFP	850 nm	LC	50/125 μm multimode optical fiber cable	550 m (1804 ft.)
			62/125 μm multimode optical fiber cable	275 m (902 ft.)
1000BASE-LX-SFP	1310 nm		9/125 μm single mode optical fiber cable	10 km (6 mi.)
1000BASE-LH-SFP				30 km (19 mi.)
1000BASE-ZX-LR-SFP	1550 nm			40 km (25 mi.)
1000BASE-ZX-VR-SFP				70 km (43 mi.)
1000BASE-T-FD-SFP		RJ-45		100 m (328 ft.)

Table 8 describes the LEDs of the SFP ports.

**Table 5** SFP Port LEDs

LED	Description
LINK/ACT	Off — The line is not connected. Green — The line is connected. Green flashing — Data is being transmitted or received.

## Console Port

The console port is connected to the configuration terminal using an RJ-45 connector. You can use the console port for system debugging, configuration, maintenance, management, and loading application files.

The console port can also be connected to a modem for functions such as remote system debugging, configuration, maintenance, and management. You can configure the baud rate on the console port.

Table 6 lists console port specifications.

**Table 6** Console Port Specifications

Specification	Description
Port connector	RJ-45
Port standard	Asynchronous EIA/TIA-232
Baud rate	9600 bps (by default)
Transmission distance	15 m (45 ft)
Services	Connects with character terminal Connects with local or remote PC serial port and runs terminal emulation on a PC (a pair of modems are required for a remote connection)

## Ethernet Port

The Ethernet port on the Fabric is connected to a computer using an RJ-45 connector. You can use the Ethernet port for system application downloading and debugging. The Ethernet port can also be connected to devices such as a network management workstation to manage the system remotely.

Table 7 lists Ethernet port specifications.

**Table 7** Ethernet Port Specifications

Specification	Description
Port connector	RJ-45
Number of port(s)	1
Port speed	10 Mbps, half/full duplex 100 Mbps, half/full duplex MDI/MDIX auto sensing
Cable and maximum transmission distance	Category-5 twisted pair for transmission within 100 m (328 ft)
Port function	Switch software upgrade and network management

See “Electrical Port Connector” on page 78 for an illustration of the RJ-45 connector and MDI/MDI-X pinout details.

Table 8 describes the LEDs of the Ethernet port.

**Table 8** Ethernet Port LEDs

LED	Description
LINK	Off — The line is not connected. Green — The line is connected.

**Table 8** Ethernet Port LEDs (continued)

LED	Description
ACTIVE	Green — No data is being transmitted or received. Green flashing — Data is being transmitted or received.

**Module LEDs** The module LEDs show the status of the I/O modules, as described in Table 9.

**Table 9** I/O Module LEDs

LED	Status description
RUN	Green or off — The module failed or has not been inserted. Green flashing — The module is working normally.
ALM	Off — The module is working normally or has not been inserted. Green or green flashing — The module failed or is not working normally.

**Power LEDs** PWR1, PWR2, and PWR3 LEDs show the status of the power modules, as described in Table 10.

**Table 10** Power LEDs

LED	Description
OK	Green — The corresponding power module is working normally. Off — The corresponding power module is not working or has not been installed.
FAIL	Green — The corresponding power module is not working. Off — The corresponding power module works normally or has not been installed.

**Fan LED** Fan LEDs show the status of the fan frame, as described in Table 11.

**Table 11** Fan LEDs

LED	Description
OK	Green — The fan is working normally. Off — The fan is not working or has not been installed.
FAIL	Green — The fan is not working. Off — The fan is working normally or has not been installed.

**Reset Button** The reset button resets the entire system.

**Fabric 32 Submodules** The Fabric 32 provides a slot for one submodule. The Fabric 32 supports the following submodules:

- 4-Port 1000BASE-X-GBIC Submodule (3C16874)
- 4-Port 10/100/1000BASE-T Submodule (3C16873)

**4-Port 1000BASE-X-GBIC Submodule** The 4-port 1000BASE-X-GBIC submodule provides four GE full-duplex Ethernet GBIC ports.

Figure 4 illustrates the 4-port 1000BASE-X-GBIC submodule.

**Figure 4** 4-Port 1000BASE-X-GBIC Submodule

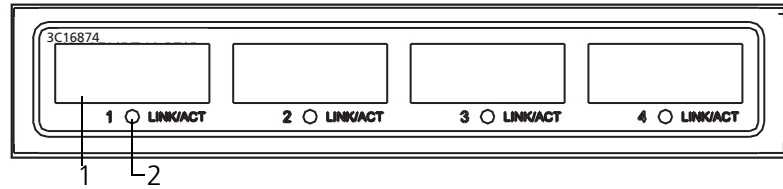

1 Ethernet GBIC port  
 2 Ethernet GBIC port LED

Table 12 describes the 4-port 1000BASE-X-GBIC submodule LEDs.

**Table 12** 4-Port 1000BASE-X-GBIC Submodule LEDs

LED	Description
LINK/ACT	Green — The link is operating normally. Off — The link is not operating. Green flashing — Data is being transmitted or received.

Table 13 lists the specifications for each of the 4-port 1000BASE-X-GBIC submodule.

**Table 13** 4-Port 1000BASE-X-GBIC Submodule Specifications

Optional GBIC Module	Central Wavelength	Connector Type	Interface Fiber Specifications	Max. Transmission Distance
1000BASE-SX-MM (3CGBIC91)	850 nm	SC	50/125 µm multi-mode fiber 62.5/125 µm Multi-mode fiber	500 m (1640 ft) 220 m (722 ft)
1000BASE-LX-SM-IR (3CGBIC92)	1310 nm	SC	9/125 µm Single-mode fiber	10 km (6 mi)
1000BASE-LX-SM (3CGBIC97)	1550 nm	SC	9/125 µm Single-mode fiber	40 km (25 mi) 70 km (43.5 mi)

**4-Port 10/100/1000BASE-T Submodule**

The 4-Port 10/100/1000BASE-T submodule provides four 10/100/1000 Mbps auto-negotiation service ports.

Figure 5 illustrates the 4-port 10/100/1000BASE-T submodule.

**Figure 5** 4-Port 10/100/1000BASE-T Submodule

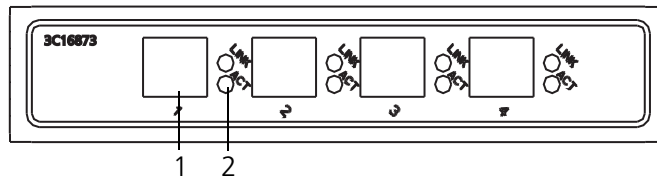

1 Ethernet port  
 2 Ethernet port LEDs

Table 14 describes the 4-port 10/100/1000BASE-T submodule LEDs.

**Table 14** 4-Port 10/100/1000BASE-T Submodule LEDs

LED	Description
LINK	Off — The link is not operating. On — The link is operating normally.
ACT	Off — No data is being transmitted or received. Green flashing — Data is being transmitted or received.

Table 15 lists specifications of the 4-port 10/100/1000BASE-T submodule.

**Table 15** 4-Port 10/100/1000BASE-T Submodule Specifications

Specification	Description
Connector type	RJ-45
Number of ports	4
Port speed	1000 Mbps full duplex 100 Mbps half/full duplex 10 Mbps half/full duplex MDI/MDI-X auto-sensing
Cable and maximum transmission distance	Category 5 twisted pair up to 100 m (328 ft)

See “Electrical Port Connector” on page 78 for an illustration of the RJ-45 connector and MDI/MDI-X pinout details.

## I/O Modules

The Switch 7750 provides multiple slots for I/O modules below the Fabric slots. The following I/O modules are supported:

- 48-port 10/100BASE-T FE PoE Module (3C16891)
- 48-port 10/100/1000BASE-T PoE Module (3C16890)
- 48-port 10/100BASE-TX FE Module (3C16889)
- 48-port 10/100/1000BASE-T Module (3C16888)
- 48-port 100BASE-X SFP Module
- 20-Port 10/100/1000BASE-T Module (3C16863A)
- 20-Port 100BASE-X-SFP Module (3C16862A)
- 12-port 10/100/1000BASE-T and 4-port 1000BASE-X SFP Module (3C168916)
- 12-port 1000BASE-X SFP and 4-port 10/100/1000BASE-T Module (3C186917)
- 8-port 1000BASE-X GBIC Module (3C16858)
- 8-port 10/100/1000BASE-T GE Module (3C16859)
- 100Base-FX SFP mode (3C16865915)

Consider the following when selecting I/O modules:

- You can configure several I/O modules of the same type
- Any combination of I/O modules can be inserted but only PoE I/O modules provide the features of power over Ethernet.

- You must select I/O module port cables that are compatible with each installed I/O module

### 48-port 10/100BASE-T FE PoE Module

The 48-port 10/100BASE-T FE PoE module provides 48 10/100 Mbps auto-sensing Ethernet ports that provide a remote power supply to powered devices

Figure 12 illustrates the 48-port 10/100BASE-T FE PoE module.

**Figure 6** 48-port 10/100BASE-T FE PoE Module

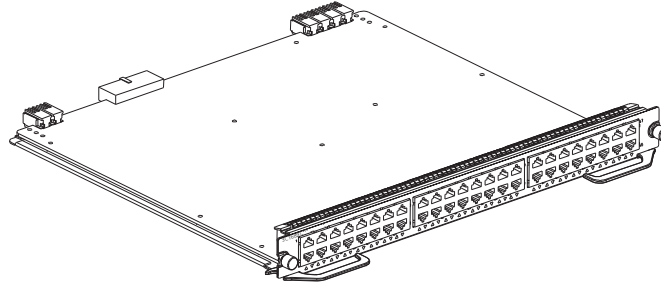
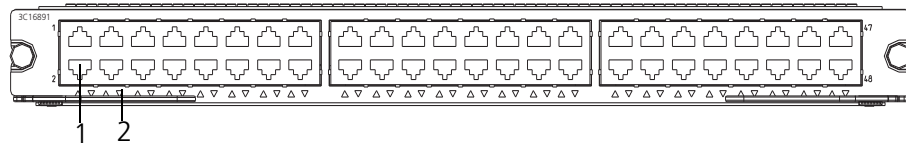

Figure 13 illustrates the front panel and LEDs of the 48-port 10/100BASE-T FE PoE module.

**Figure 7** Front Panel of the 48-port 10/100BASE-T FE PoE Module



- 1 Ethernet port
- 2 Ethernet port LED

Table 22 describes the 48-port 10/100BASE-T FE PoE Module LEDs.

**Table 16** module LED

LED	Description
LINK/ACT	Green — The port is connected. Off — The port is not connected. Green flashing — Data is being transmitted or received.

Table 23 describes the specifications for the 48-port 10/100BASE-T FE PoE module.

**Table 17** Specifications for the 48-port 10/100BASE-T FE PoE Module

Specification	Description
CPU	MPC8241
BootROM	512 KB
SDRAM	128 M
Dimensions (L X W)	366.7 x 340 mm (14.4 x 13.4 in.)
Maximum power consumption	35 W
Connector	RJ-45
Number of ports	48

**Table 17** Specifications for the 48-port 10/100BASE-T FE PoE Module (continued)

Specification	Description
Port transmission speed	10/100 Mbps half-/full-duplex MDI/MDI-X auto-sensing
Cables and maximum transmission distance	100 m (328 ft.)
Maximum power each port provides	15.4 W
Compliance	IEEE802.3 IEEE802.3u IEEE802.3x IEEE802.3ad IEEE802.1p IEEE802.1D IEEE802.1Q IEEE802.1X IEEE802.1s IEEE802.1w IEEE802.3af

**48-port  
10/100/1000BASE-T PoE  
Module**

The 48-port 10/100/1000BASE-T PoE module provides 48 10/100/1000 Mbps auto-sensing Ethernet ports that provide a remote power supply to powered devices.

Figure 12 illustrates the 48-port 10/100/1000BASE-T PoE module.

**Figure 8** 48-port 10/100/1000BASE-T PoE Module

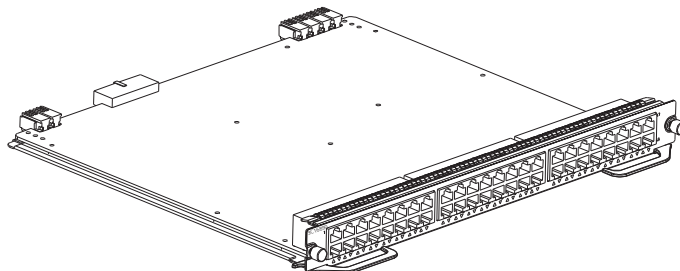
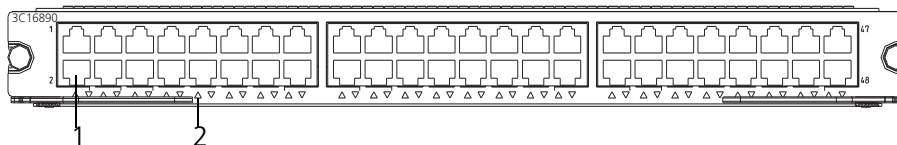

Figure 13 illustrates the front panel and LEDs of the 48-port 10/100/1000BASE-T PoE module.

**Figure 9** Front Panel of the 48-port 10/100/1000BASE-T PoE Module



- 1 Ethernet port
- 2 Ethernet port LED



Table 22 describes the 48-port 10/100/1000BASE-T PoE module LEDs.

**Table 18** 48-port 10/100/1000BASE-T PoE Module LED

LED	Description
LINK/ACT	Green — The port is connected. Off — The port is not connected. Green flashing — Data is being transmitted or received.

Table 23 describes the specifications of the 48-port 10/100/1000BASE-T PoE module.

**Table 19** Specifications for the 48-port 10/100/1000BASE-T PoE Module

Specification	Description
CPU	MPC8241
BootROM	512 KB
SDRAM	128 M
Dimensions (L X W)	366.7 x 340 mm (14.4 x 13.4 in.)
Maximum power consumption	70 W
Connector	RJ-45
Number of ports	48
Port transmission speed	10/100/1000 Mbps half-/full-duplex MDI/MDIX auto-sensing
Cables and maximum transmission distance	Category 5 twisted pair with a maximum distance of 100 m (328 ft.)
Compliance	IEEE802.3ab IEEE802.3 IEEE802.3i IEEE802.3x IEEE802.1p IEEE802.1D IEEE802.1Q IEEE802.1X IEEE802.1s IEEE802.1w

#### 48-port 10/100BASE-TX FE Module

The 48-port 10/100BASE-TX FE module provides 48 10/100 Mbps auto-sensing Ethernet electrical ports.

Figure 10 illustrates the 48-port 10/100BASE-T FE module.

**Figure 10** 48-port 10/100BASE-T FE Module

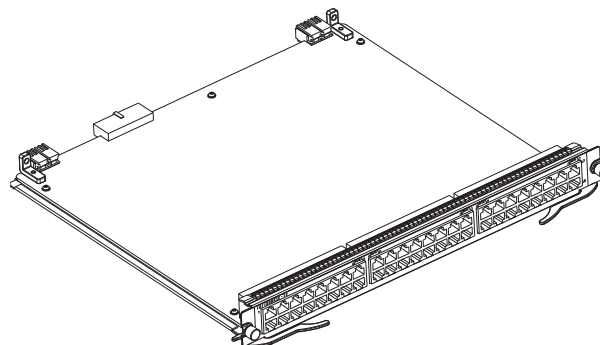
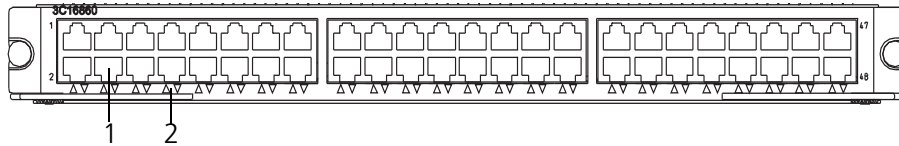

Figure 11 illustrates the front panel and LEDs of the 48-port 10/100BASE-TX FE module.

**Figure 11** Front Panel of the 48-Port 10/100BASE-TX FE module



- 1 Ethernet port
- 2 Ethernet port LED

Each 100 Mbps Ethernet port has a green LED, indicating LINK/ACTIVE status.

Table 20 describes the 48-port 10/100BASE-TX FE module LED.

**Table 20** 48-Port 10/100BASE-TX FE module LED

LED	Description
LINK/ACT	Green — The port is connected. Off — The port is not connected. Green flashing — Data is being transmitted or received.

Table 21 describes the specifications of the 48-port 10/100BASE-TX FE module.

**Table 21** Specifications for the 48-Port 10/100BASE-TX FE Module

Specification	Description
CPU	MPC850
BootROM	512 KB
SDRAM	64 MB
Dimensions (L X W)	366.7 x 340 mm (14.5 x 13.4 in)
Maximum power consumption	75 W
Connector	RJ-45
Number of ports	48
Port transmission speed	10/100 Mbps half/full duplex MDI/MDIX auto-sensing
Cables and maximum transmission distance	Cables are 2 100-ohm Category-5 twisted pairs up to 100 m (300 ft).
Compliance	IEEE802.3 IEEE802.3u IEEE802.3x IEEE802.3ad IEEE802.1p IEEE802.1D IEEE802.1Q IEEE802.1X IEEE802.1s IEEE802.1w

See “Electrical Port Connector” on page 78 for an illustration of the RJ-45 connector and MDI/MDI-X pinout details.

### 48-port 10/100/1000BASE-T Module

The 48-port 10/100/1000BASE-T module provides 48 10/100/1000 Mbps auto-sensing Ethernet electrical ports.

Figure 12 illustrates the 48-port 10/100/1000BASE-T module.

**Figure 12** 48-port 10/100/1000BASE-T Module

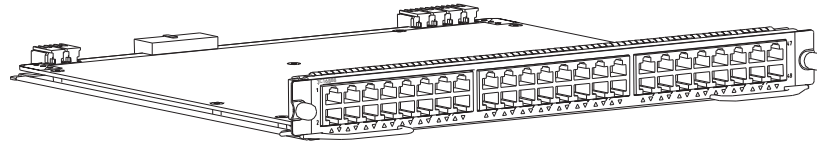
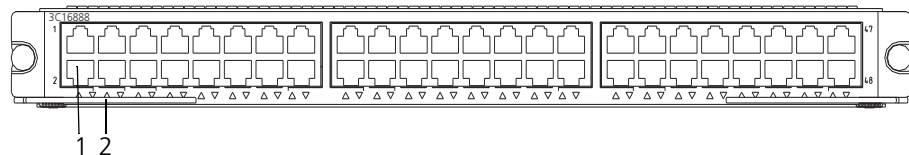

Figure 13 illustrates the front panel and LEDs of the 48-port 10/100/1000BASE-T module.

**Figure 13** Front Panel of the 48-port 10/100/1000BASE-T Module



1 Ethernet port

2 Ethernet port LED

Table 22 describes the 48-port 10/100/1000BASE-T module LEDs.

**Table 22** 48-port 10/100/1000BASE-T Module LED

LED	Description
LINK/ACT	Green — The port is connected. Off — The port is not connected. Green flashing — Data is being transmitted or received.

Table 23 describes the specifications of the 48-port 10/100/1000BASE-T module.

**Table 23** Specifications for the 48-port 10/100/1000BASE-T Module

Specification	Description
CPU	MPC8241
BootROM	512 KB
SDRAM	128 M
Dimensions (L X W)	366.7 x 340 mm (14.4 x 13.4 in.)
Maximum power consumption	70 W
Connector	RJ-45
Number of ports	48
Port transmission speed	10/100/1000 Mbps half-/full-duplex MDI/MDI-X auto-sensing
Cables and maximum transmission distance	Category 5 twisted pair with a maximum transmission distance of 100 m (328 ft.)

**Table 23** Specifications for the 48-port 10/100/1000BASE-T Module (continued)

Specification	Description
Compliance	1EEE 802.3ab 1EEE 802.3 1EEE 802.3u 1EEE 802.3x 1EEE 802.1p 1EEE 802.1D 1EEE 802.1Q 1EEE 802.1X 1EEE 802.1s 1EEE 802.1w

**48-port 100BASE-X SFP Module**

The 48-port 100BASE-X SFP module provides 48 100 Mbps full-duplex Ethernet optical ports.

Figure 14 illustrates the 48-port 100BASE-X SFP module.

**Figure 14** 48-port 48-port 100BASE-X SFP Module

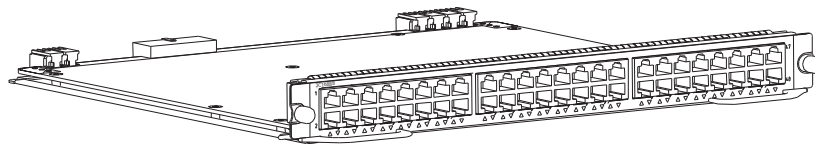
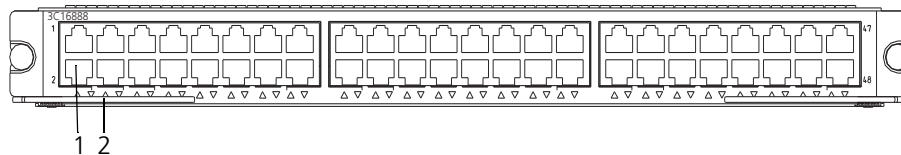

Figure 15 illustrates the front panel and LEDs of the 48-port 100BASE-X SFP module.

**Figure 15** Front Panel of the 48-port 48-port 100BASE-X SFP Module



- 1 Ethernet port
- 2 Ethernet port LED

Table 24 describes the 48-port 100BASE-X SFP module LEDs.

**Table 24** 48-port 100BASE-X SFP Module LED

LED	Description
LINK/ACT	Green — The port is connected. Off — The port is not connected. Green flashing — Data is being transmitted or received.

Table 25 describes the specifications of the 48-port 100BASE-X SFP module.

**Table 25** Specifications for the 48-port 100BASE-X SFP Module

Specification	Description
CPU	MPC8241
BootROM	512 KB
SDRAM	128 M

**Table 25** Specifications for the 48-port 100BASE-X SFP Module (continued)

Specification	Description
Dimensions (L X W)	366.7 x 340 mm (14.4 x 13.4 in.)
Maximum power consumption	36.5 W
Connector	LC
Number of ports	48
SFP module	100BASE-FX-MM-SFP 100BASE-FX-SM-SFP 100BASE-FX-SM-LR-SFP 100BASE-FX-SM-VR-SFP
Port transmission speed	100 Mbps full-duplex
Compliance	1EEE 802.3 1EEE 802.3u 1EEE 802.3x 1EEE 802.3ad 1EEE 802.1p 1EEE 802.1D 1EEE 802.1Q 1EEE 802.1X 1EEE 802.1s 1EEE 802.1w

Table 26 lists the cables for the 48-port 100BASE-X (SFP) ports

**Table 26** Cables for the 48-port 100BASE-X SFP Module

SFP module	Central wave-length	Connector	Matching cable	Maximum transmission distance
100BASE-FX-MM-SFP	1310nm	LC	multimode optical fiber cable	2 km (1.2 mi)
100BASE-FX-SM-SFP	1310nm			15 km (9.3 mi)
100BASE-FX-SM-LR-SFP	1310nm		9/125 $\mu$ m single mode optical fiber cable	40 km (24.9 mi)
100BASE-FX-SM-VR-SFP	1550nm			70km (43 mi)

### 24-port 100BASE-FX MMF FE Module

The 24-port 100BASE-FX MMF FE module provides 24 100 Mbps multi-mode Ethernet optical port service channels.

Figure 16 illustrates the 24-port 100BASE-FX MMF FE module.

**Figure 16** 24-Port 100BASE-FX MMF FE Module

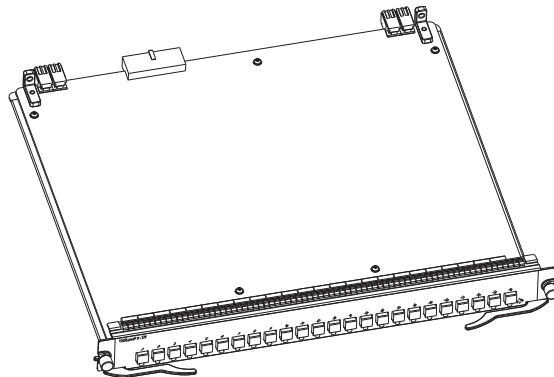

Each 100 Mbps optical port has a green LED, as shown in Figure 17.

**Figure 17** Front Panel of the 24-Port 100BASE-FX MMF FE Module

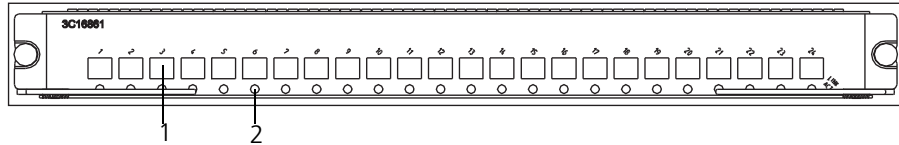

- 1 Ethernet port
- 2 Ethernet port LED

Table 27 describes the status of the 24-port 100BASE-FX MMF FE module LEDs.

**Table 27** 24-Port 100BASE-FX MMF FE Module LEDs

LED	Description
LINK/ACT	Green — The port is connected. Off — The port is not connected. Green flashing — Data is being transmitted or received.

The 24-port 100BASE-FX MMF FE module requires a 62.5/125 μm multi-mode optical fiber cable with an MT-RJ connector and a central wavelength of 1300 nm.

Table 28 describes the specifications of the 24-port 100BASE-FX MMF FE module.

**Table 28** Specifications for the 24-Port 100BASE-FX MMF FE Module

Specification	Description
CPU	MPC850
BootROM	512 KB
SDRAM	64 MB
Dimensions (L x W)	366.7 x 340 mm (14.5 x 13.4 in)
Maximum power consumption	55 W
Connector type	MT-RJ
Number of ports	24
Port transmission speed	100 Mbps, full-duplex

**Table 28** Specifications for the 24-Port 100BASE-FX MMF FE Module (continued)

Specification	Description
Cables and maximum transmission distance	62.5/125 $\mu\text{m}$ multi-mode optical fiber up to 2 km (1.3 mi)
Compliance	IEEE 802.3 IEEE 802.3i IEEE 802.3u IEEE 802.3x

### 20-Port 10/100/1000BASE-T Module

The 20-Port 10/100/1000BASE-T module provides 20 10/100/1000BASE-T auto-sensing Ethernet ports.

Figure 18 illustrates the 20-Port 10/100/1000BASE-T Module.

**Figure 18** 20-Port 10/100/1000BASE-T Module

Figure 19 illustrates the front panel of the 20-port 10/100/1000BASE-T module.

**Figure 19** Front Panel of the 20-Port 10/100/1000BASE-T Module

- 1 Ethernet port
- 2 Ethernet port LED

Table 29 describes the 20-port 10/100/1000BASE-T module LEDs.

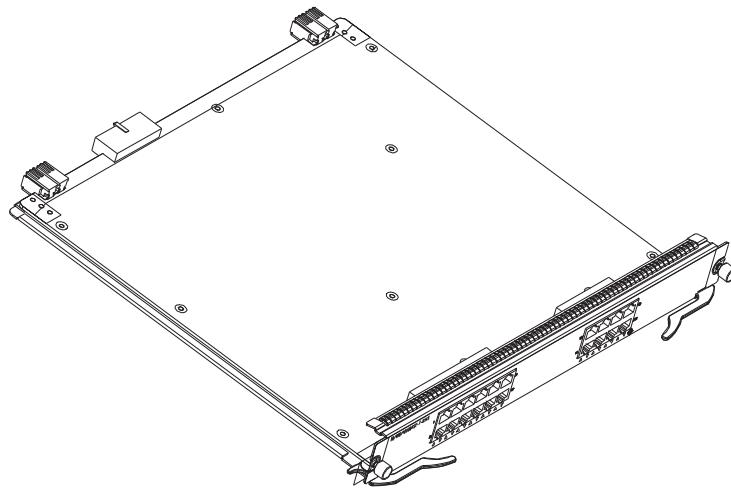
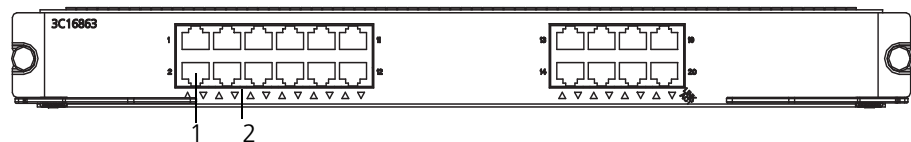
**Table 29** 20-Port 10/100/1000BASE-T Module LEDs

LED	Description
LINK/ACT	Off — The port is not operating. On — The port is operating. Green flashing — The port is transmitting or receiving data

Table 30 lists specifications of the 20-port 10/100/1000BASE-T module.

**Table 30** Specifications for the 20-Port 10/100/1000BASE-T Module

Specification	Description
CPU	MPC8241LZU200
BootROM	512 KB
SDRAM	64 MB
Dimensions (L x W)	366.7 x 340 mm (14.5 x 13.4 in)
Power consumption	45 W
Connector	RJ-45
Number of ports	20
Transmission rate	10 Mbps half/full duplex 100 Mbps half/full duplex 1000 Mbps full duplex
Cable and maximum transmission distance	Category-5 twisted pair 100 m (300 ft)
Compliance	IEEE 802.3ab IEEE 802.3 IEEE 802.3u IEEE 802.3x IEEE 802.1D IEEE 802.1Q

**20-Port 1000BASE-X-SFP Module**

The 20-port 1000BASE-X-SFP module provides 20 1000 BASE-X full duplex ports and uses an SFP cable.

Figure 20 illustrates the 20-port 1000BASE-X-SFP module.

**Figure 20** 20-Port 1000BASE-X-SFP Module

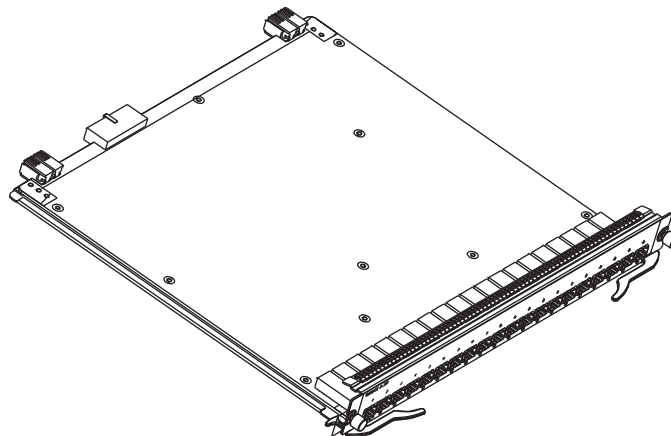
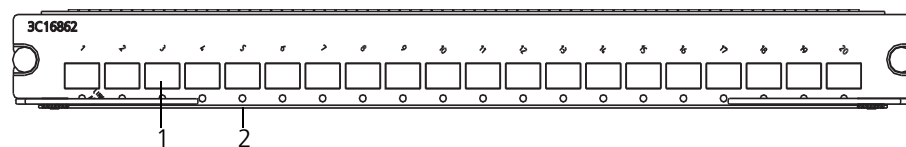

Figure 21 illustrates the front panel of the 20-port 1000BASE-X-SFP module.

**Figure 21** Front Panel of the 20-Port 1000BASE-X-SFP Module





- 1 Ethernet port
- 2 Ethernet port LED

Table 31 describes the 20-port 1000BASE-X-SFP module LEDs.

**Table 31** 20-Port 1000BASE-X-SFP Module LEDs

LED	Description
LINK/ACT	Off — The port is not operating. On — The port is operating. Green flashing — The port is transmitting or received data

Table 32 lists specifications of the 20-port 1000BASE-X-SFP module.

**Table 32** Specifications for the 20-Port 1000BASE-X-SFP Module

Specification	Description
CPU	MPC8241LZU200
BootROM	512 KB
SDRAM	64 MB
Dimensions (L x W)	366.7 x 340 mm (14.5 x 13.4 in)
Power consumption	35 W
Connector	SFP socket
Number of ports	20
Transmission rate	1000 Mbps full duplex
Cable and maximum transmission distance	1000BASE-SX-SFP (multi-mode optical fiber, short haul) 1000BASE-LX-SFP (single mode optical fiber, 1310 nm) 1000BASE-LH-SFP (single mode optical fiber, 1310 nm) 1000BASE-ZX-LR-SFP (single mode optical fiber, 1550 nm) 1000BASE-ZX-VR-SFP (single mode optical fiber, 1550 nm)
Compliance	IEEE 802.3z IEEE 802.1p IEEE 802.1Q IEEE 802.1D IEEE 802.3x IEEE 802.3ad

**12-port  
10/100/1000BASE-T  
and  
4-port 1000BASE-X SFP  
Module**

The 12-port 10/100/1000BASE-T and 4-port 1000BASE-X SFP module provides 12 10/100/1000 BASE-T ports and 4 1000BASE-X ports.

Figure 22 illustrates the 12-port 10/100/1000BASE-T and 4-port 1000BASE-X SFP module.

**Figure 22** 12-port 10/100/1000BASE-T and 4-port 1000BASE-X SFP Module

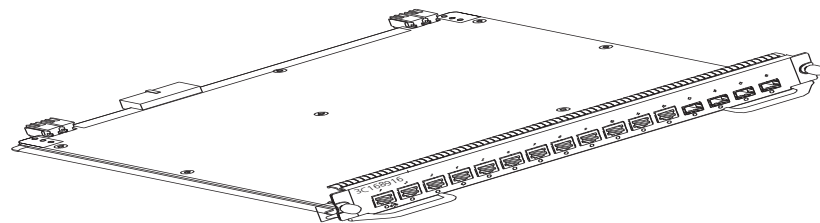
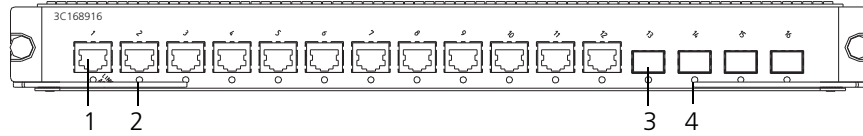

Figure 23 illustrates the front panel of the 12-port 10/100/1000BASE-T and 4-port 1000BASE-X SFP module.

**Figure 23** Front Panel of the 12-port 10/100/1000BASE-T and 4-port 1000BASE-X SFP Module



- 1 Ethernet port
- 2 Ethernet port LED
- 3 SFP port
- 4 SFP LED

Table 31 describes the 12-port 10/100/1000BASE-T and 4-port 1000BASE-X SFP module LEDs.

**Table 33** 12-port 10/100/1000BASE-T Module LEDs

LED	Description
LINK/ACT	Off — The port is not operating. On — The port is operating. Green flashing — The port is transmitting or receiving data.

Table 34 lists specifications of the 12-port 10/100/1000BASE-T and 4-port 1000BASE-X SFP module.

**Table 34** Specifications for the 12-port 10/100/1000BASE-T and 4-port 1000BASE-X SFP Module

Specification	Description
CPU	MPC8245
BootROM	512 KB
SDRAM	256 MB
Dimensions (L x W)	366.7 x 340 mm (14.5 x 13.4 in)
Power consumption	45 W
Connector	SFP socket
Number of ports	12 10/100/1000BASE-T Ethernet ports 4 1000BASE-X (SFP) Ethernet ports
Transmission rate	1000 Mbps full duplex (optical port) 10 Mbps half/full duplex (electrical port) 100 Mbps half/full duplex (electrical port) 1000 Mbps full duplex (electrical port)
Ethernet cable and maximum transmission distance	100 m (328 ft) over category-5 twisted pair cable
Compliance	IEEE 802.3 IEEE 802.3u IEEE 802.3z IEEE 802.3ab IEEE 802.1p IEEE 802.1Q IEEE 802.1D IEEE 802.1X IEEE 802.1s IEEE 802.1w IEEE 802.3x IEEE 802.3ad

Table 35 lists the cables for the 1000BASE-X (SFP) ports.

**Table 35** SFP Cables for the 12-port 10/100/1000BASE-T and 4-port 1000BASE-X SFP Module

SFP module	Central wavelength	Connector	Matching cable	Maximum transmission distance
SFP-GE-SX-MM850-A	850nm	LC	50/125 $\mu$ m multimode optical fiber cable	550 m (1804 ft)
			62.5/125 $\mu$ m multimode optical fiber cable	275 m (902 ft)
SFP-GE-LX-SM1310-A	1310nm	LC	9/125 $\mu$ m single mode optical fiber cable	10 km (6 mi)
SFP-GE-LH40-SM1310				40 km (about 25 mi)
SFP-GE-LH40-SM1550	1550nm	LC	9/125 $\mu$ m single mode optical fiber cable	40 km (about 25 mi)
SFP-GE-LH70-SM1550				70 km (43 mi)
SFP-GE-LH100-SM1550				100km (62 mi)
SFP-GE-LH70-SM1470-CW				70km (43 mi)
SFP-GE-LH70-SM1490-CW	1490nm	LC	9/125 $\mu$ m single mode optical fiber cable	70km (43 mi)
SFP-GE-LH70-SM1510-CW	1510nm	LC	9/125 $\mu$ m single mode optical fiber cable	70km (43 mi)
SFP-GE-LH70-SM1530-CW	1530nm	LC	9/125 $\mu$ m single mode optical fiber cable	70km (43 mi)
SFP-GE-LH70-SM1550-CW	1550nm	LC	9/125 $\mu$ m single mode optical fiber cable	70km (43 mi)
SFP-GE-LH70-SM1570-CW	1570nm	LC	9/125 $\mu$ m single mode optical fiber cable	70km (43 mi)
SFP-GE-LH70-SM1590-CW	1590nm	LC	9/125 $\mu$ m single mode optical fiber cable	70km (43 mi)
SFP-GE-LH70-SM1610-CW	1610nm	LC	9/125 $\mu$ m single mode optical fiber cable	70km (43 mi)
SFP-GE-T	-	RJ45	-	100m (328 ft)

**12-port 1000BASE-X SFP and 4-port 10/100/1000BASE-T Module**

The 12-port 1000BASE-X SFP and 4-port 10/100/1000BASE-T module provides 12 1000BASE-X SFP ports and 4 10/100/1000BASE-X SFP ports.

Figure 24 illustrates the 12-port 1000BASE-X SFP and 4-port 10/100/1000BASE-T module.

**Figure 24** 12-port 1000BASE-X SFP and 4-port 10/100/1000BASE-T Module

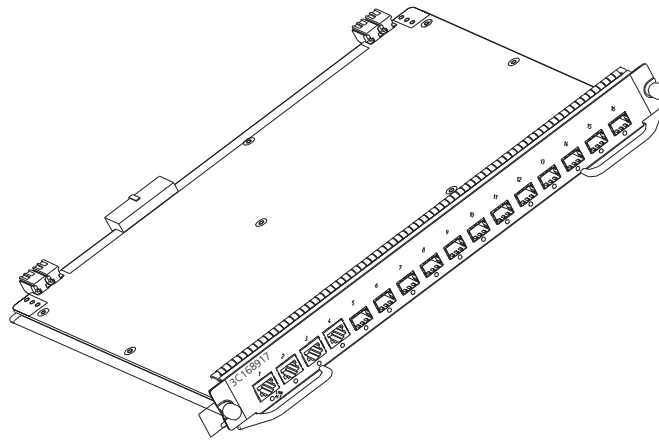
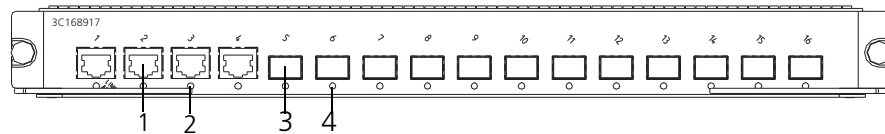

Figure 25 illustrates the front panel of the 12-port 1000BASE-X SFP module.

**Figure 25** Front Panel of the 12-port 1000BASE-X SFP and 4-port 10/100/1000BASE-T Module



- 1 SFP port
- 2 SFP port LED
- 3 Ethernet port
- 4 Ethernet port LED

Table 36 describes the 12-port 1000BASE-X SFP and 4-port 10/100/1000BASE-T module LEDs.

**Table 36** 12-port 1000BASE-X SFP and 4-port 10/100/1000BASE-T Module LEDs

LED	Description
LINK/ACT	Off — The port is not operating. On — The port is operating. Green flashing — The port is transmitting and receiving data.

Table 37 lists specifications of the 12-port 1000BASE-X SFP and 4-port 10/100/1000BASE-T module.

**Table 37** Specifications for the 12-port 1000BASE-X SFP and 4-port 10/100/1000BASE-T Module

Specification	Description
CPU	MPC8241
BootROM	512 KB
SDRAM	64 MB
Dimensions (L x W)	366.7 x 340 mm (14.5 x 13.4 in)
Power consumption	35 W
Connector	RJ-45, LC

**Table 37** Specifications for the 12-port 1000BASE-X SFP and 4-port 10/100/1000BASE-T Module (continued)

Specification	Description
Number of ports	16
Transmission rate	1000 Mbps full duplex (optical/electrical) 10/100 Mbps half-/full-duplex (electrical)
Cable and maximum transmission distance	Category-5 twisted pair with maximum transmission distance of 100 m (328 ft)
Compliance	IEEE 802.3 IEEE 802.3u IEEE 802.3z IEEE 802.3ab IEEE 802.1p IEEE 802.1Q IEEE 802.1D IEEE 802.1X IEEE 802.1s IEEE 802.1w IEEE 802.3x IEEE 802.3ad

Table 38 lists the cables for the 1000BASE-X SFP ports.

**Table 38** SFP Cables for the 12-port 1000BASE-X SFP and 4-port 10/100/1000BASE-T Module

SFP module	Central wavelength	Connector	Matching cable	Maximum transmission distance
SFP-GE-SX-MM850-A	850nm	LC	50/125 $\mu$ m multimode optical fiber cable	550 m (1804 ft)
			62.5/125 $\mu$ m multimode optical fiber cable	275 m (902 ft)
SFP-GE-LX-SM1310-A	1310nm	LC	9/125 $\mu$ m single mode optical fiber cable	10 km (6 mi)
SFP-GE-LH40-SM1310				40 km (about 25 mi)
SFP-GE-LH40-SM1550	1550nm	LC	9/125 $\mu$ m single mode optical fiber cable	40 km (about 25 mi)
SFP-GE-LH70-SM1550				70 km (43 mi)
SFP-GE-LH100-SM1550				100km (62 mi)
SFP-GE-LH70-SM1470-CW	1470nm	LC	9/125 $\mu$ m single mode optical fiber cable	70km (43 mi)
SFP-GE-LH70-SM1490-CW	1490nm	LC	9/125 $\mu$ m single mode optical fiber cable	70km (43 mi)
SFP-GE-LH70-SM1510-CW	1510nm	LC	9/125 $\mu$ m single mode optical fiber cable	70km (43 mi)
SFP-GE-LH70-SM1530-CW	1530nm	LC	9/125 $\mu$ m single mode optical fiber cable	70km (43 mi)
SFP-GE-LH70-SM1550-CW	1550nm	LC	9/125 $\mu$ m single mode optical fiber cable	70km (43 mi)
SFP-GE-LH70-SM1570-CW	1570nm	LC	9/125 $\mu$ m single mode optical fiber cable	70km (43 mi)

**Table 38** SFP Cables for the 12-port 1000BASE-X SFP and 4-port 10/100/1000BASE-T Module

SFP module	Central wavelength	Connector	Matching cable	Maximum transmission distance
SFP-GE-LH70-SM1590-CW	1590nm	LC	9/125 μm single mode optical fiber cable	70km (43 mi)
SFP-GE-LH70-SM1610-CW	1610nm	LC	9/125 μm single mode optical fiber cable	70km (43 mi)
SFP-GE-T	-	RJ45	-	100m (328 ft)

**8-port 1000BASE-X GBIC Module**

The 8-port 1000BASE-X GBIC module provides 8 external GBIC module ports. A GBIC module is used for each data receiving/transmitting channel. The following modules are available:

- 3CGBIC91
- 3CGBIC92
- 3CGBIC97

Figure 26 illustrates the 8-port 1000BASE-X GBIC module.

**Figure 26** 8-Port 1000BASE-X GBIC Module

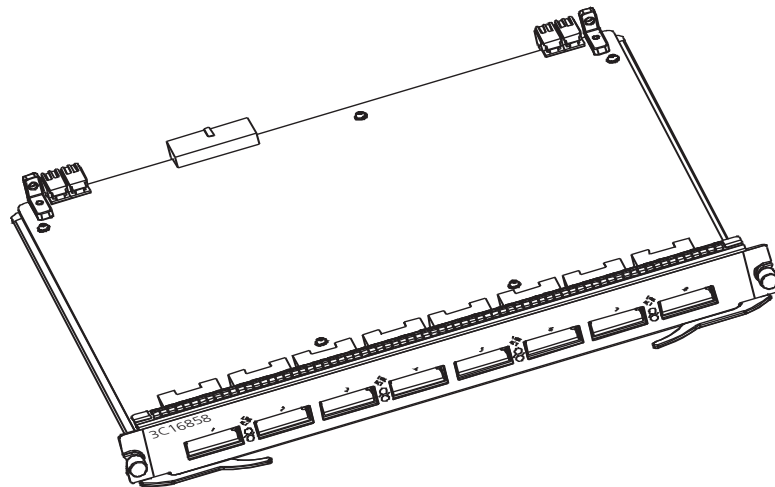

Every GBIC port has a LED, as shown in Figure 27.

**Figure 27** Front Panel of the 8-Port 1000BASE-X GBIC Module

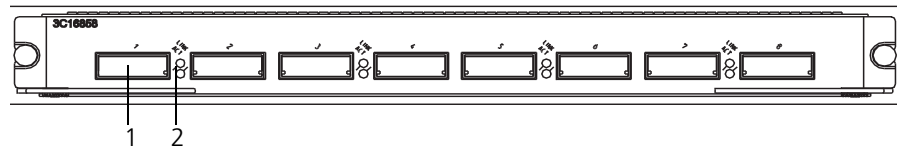

- 1 GBIC port
- 2 GBIC port LED

Table 39 describes the 8-Port 1000BASE-X GBIC module LEDs.

**Table 39** 8-Port 1000BASE-X GBIC Module LEDs

LED	Description
LINK	Off — The link is not connected Green — The link is connected
ACT	Off — No data is being transmitted or received Green flashing — Data is being transmitted or received

The cables for each of the supported 8GBIC modules are described in Table 40.

**Table 40** GBIC Module Port Cables

GBIC Module Type	Central Wave Length
3CGBIC91	850 nm
3CGBIC92	1550 nm
3CGBIC97	1550 nm

Table 41 describes the specifications of the 8-port 1000BASE-X GBIC module.

**Table 41** Specifications for the 8-Port 1000BASE-X GBIC Module

Specification	Description
CPU	MPC850
BootROM	512 KB
SDRAM	64 MB
Dimensions (L x W)	366.7 x 340 mm (14.5 x 13.4 in)
Maximum power consumption	50 W
Number of ports	8
Optional GBIC module types	3CGBIC 91 3CGBIC 92 3CGBIC 97
Port transmission speed	1000 Mbps, full duplex
Compliance	IEEE 802.3z IEEE 802.3x

### **8-port 10/100/1000BASE-T GE Module**

The 8-port 10/100/1000BASE-T GE module provides 8 external 10/100/1000 Mbps auto-sensing Ethernet electrical ports.

Figure 28 illustrates the 8-port 10/100/1000BASE-T GE module.

**Figure 28** 8-Port 10/100/1000BASE-T GE Module

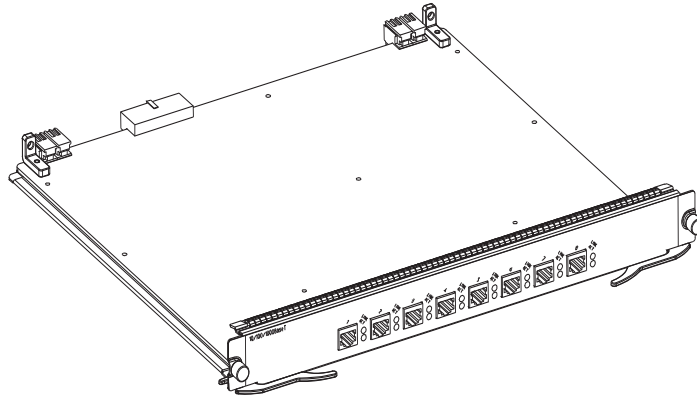

Each port on the 8-port 10/100/1000BASE-T GE module has 2 LEDs, as shown in Figure 29.

**Figure 29** Front Panel of the 8-Port 10/100/1000BASE-T GE Module

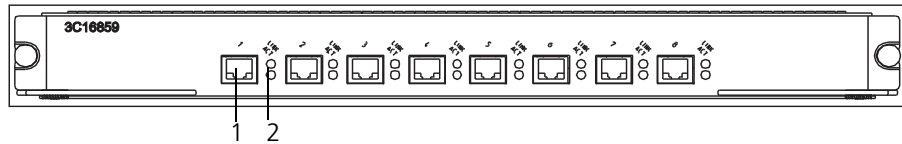

- 1 Ethernet port
- 2 Ethernet port LEDs

Table 42 describes the LEDs on the 8-port 10/100/1000BASE-T GE module.

**Table 42** 8-Port 10/100/1000BASE-T GE Module LEDs

LED	Description
LINK	Off — The link is not connected. Green — The link is connected.
ACT	Off — No data is being transmitted or received. Green flashing — Data is being transmitted or received.

Specifications of the 8-port 10/100/1000BASE-T GE module are described in Table 43.

**Table 43** Specifications for the 8-Port 10/100/1000BASE-T GE Module

Specification	Description
CPU	MPC850
BootROM	512 Kb
SDRAM	64 MB
Dimensions (L x W)	366.7 x 340 mm (14.5 x 13.4 in)
Maximum power consumption	50 W
Connector type	RJ-45
Number of ports	8



**Table 43** Specifications for the 8-Port 10/100/1000BASE-T GE Module (continued)

Specification	Description
Port transmission speed	10 Mbps, half/full duplex 100 Mbps, half/full duplex 1000 Mbps, full duplex
Cables and maximum transmission distance	4 100-ohm Category-5 non-shielded twisted pairs up to 100 m (300 ft).
Compliance	IEEE 802.3ab IEEE802.3 IEEE802.3u IEEE802.3x

## Power Module

Only one AC power module is required for the 4-slot chassis, although two power module slots are provided to implement N+1 redundancy.

The 7-slot and 8-slot chassis provides three power module slots to implement N+1 redundancy. However, two power modules are sufficient to power one of these fully loaded Switch 7700 systems.

The 8-slot chassis offers both AC and DC power modules. Table 44 describes the specifications of each type of power module.

**Table 44** Specifications for AC and DC Power Modules

Specification	AC Power Module	DC Power Module
Input	100 V to 240 V, 47 to 63 Hz	-48 V to -60 V
Maximum output	460 W	460 W

## Power Distribution

The Switch 7750 power distribution box is installed on the chassis floor in the back of the chassis. It filters, connects, disconnects, and distributes electrical current to the switch.

The power distribution box for the 4-slot chassis has two inputs and each input has a separate ON/OFF switch. One input can support the normal operation of one power module. Both AC inputs must be connected and switched on to provide power to both power modules and to offer N+1 AC power redundancy. When two power modules are installed but only one AC power input is working, only one power module will operate. However, the power module LEDs on the Fabric display alarm information for the power module that is not working.

The power distribution box for the 7-slot and 8-slot chassis has two inputs and two ON/OFF switches. One input can support the normal operation of three AC power modules at the same time. When both AC power inputs are connected and switched on, the power distribution box offers N+1 AC power redundancy.

## External PoE Power System

The Switch 7750 supports power-over-Ethernet (PoE). When the Switch 7750 is equipped with an external PoE power system and PoE-capable I/O modules, it can provide -48 V DC power to remote powered devices (PDs), such as IP phones, WLAN APs, and network cameras through twisted pair cable.

Figure 30 illustrates the Switch 7750 PoE power system.

**Figure 30** Switch 7750 PoE Power Supply

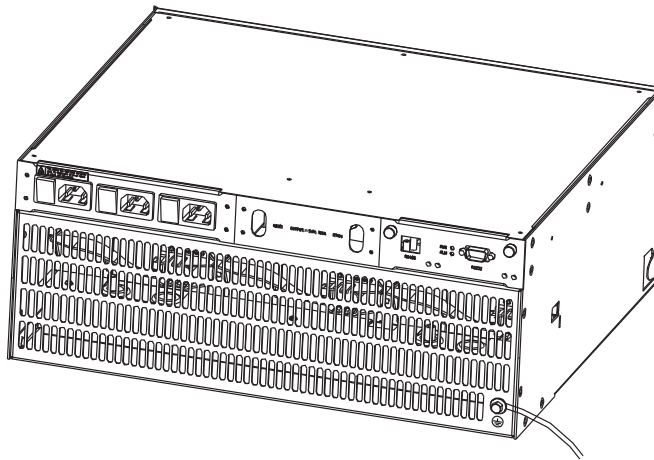

The Switch 7750 supports PoE external input power up to 2400 W.

Table 45 describes the capabilities of the Switch 7750 PoE power module.

**Table 45** PoE Power Modules

Input voltage	Power supplied		Power modules needed for redundancy
	1 Power module	2 Power module	
100 to 140 V	1200 W	2400 W	3
200 to 240 V	2400 W		2

The Switch 7750 provides power through Ethernet ports on the PoE-supported I/O modules, supporting the maximum distance of 100 m (328 ft.).

When the Switch 7750 provides power remotely, each Ethernet port can provide up to 15.4 W of power to the connected PD.

---

## Fan Assembly

The fan assembly consists of two to four individual fans and is located on the right side of the chassis:

- 4-slot chassis — 3C16871
- 7-slot chassis — 3C16856
- 8-slot chassis — 3C16855

The fans are directly connected to the backplane through connectors. Fan operation fault signals are collected and transmitted to the system alarm board through the backplane.

Figure 31 illustrates the fan assembly for the 7- and 8-slot chassis.

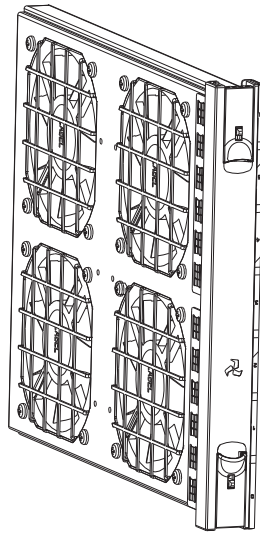
**Figure 31** Fan Assembly

## Switch 7750 Specifications

Table 46 provides detailed information about features of the Switch 7750.

**Table 46** Specifications for the Switch 7750 System

Item	4-Slot Chassis	7-Slot Chassis	8-Slot Chassis
Dimensions (W x H x D)	436 x 352.8 x 480 mm (17 x 14 x 19 in)	436 x 486.2 x 480 mm (17 x 19 x 19 in)	436 x 530.6 x 480 mm (17 x 21 x 19 in)
Weight (with all components)	50 Kg (110 lbs)	70 Kg (154 lbs)	80 Kg (177 lbs)
Fabric slots	1	1	2
I/O module slots	3	6	
Fabric submodule options	4-port 1000BASE-X-GBIC 4-port 10/100/1000BASE-T		
I/O module options	48-port 10/100BASE-T FE PoE Module 48-port 10/100/1000BASE-T PoE Module 48-port 10/100BASE-TX FE Module 48-port 10/100/1000BASE-T Module 48-port 100BASE-X SFP Module 20-Port 10/100/1000BASE-T Module 20-Port 1000BASE-X-SFP Module 12-port 10/100/1000BASE-T and 4-port 1000BASE-X SFP Module 12-port 1000BASE-X SFP and 4-port 10/100/1000BASE-T Module 8-port 1000BASE-X GE Module 8-port 10/100/1000BASE-T GE Module 1-port 10GBASE-X-XENPAK Module		
PoE Fabric performance	96 Gbps	96 Gbps	96 Gbps
Fabric performance	32 Gbps	64 Gbps	64 Gbps
Maximum aggregate system performance	72 Gbps 54 Mpps	144 Gbps 108 Mpps	
Packet processing	24 Mpps	48 Mpps	48 Mpps

**Table 46** Specifications for the Switch 7750 System (continued)

<b>Item</b>	<b>4-Slot Chassis</b>	<b>7-Slot Chassis</b>	<b>8-Slot Chassis</b>
Input voltage	AC: 100 V to 240 V, 50 to 60 Hz		AC: 100 V to 240 V, 50 to 60 Hz  DC: -48 V to -60 V
PoE input voltage	-46 V to -55 V; 55.0 A		
Max power consumption (all components installed)	350 W	650 W	800 W
Environment temperature and humidity	0 to 40 °C (32 to 104 °F) and 10% to 90%		

# 2

## INSTALLING THE SWITCH 7750

The following sections describe how to prepare and install the components of the Switch 7750:

- Preparing to Install
- General Site Requirements
- Installation Checklist
- Installing the Chassis
- Installing the Cabling Rack
- Installing a Module
- Installing a Submodule
- Connecting the Ground Wire
- Connecting and Configuring Power
- Installing the Fan Assembly
- Installing Cables
- Connecting Module Cables
- Post-installation Checklist



**WARNING:** Only trained and qualified personnel should install and maintain 3Com products.

---

### Preparing to Install

This section provides guidelines for preparing your site and switch for installation.

#### General Safety Recommendations

Before installing your switch, note the following safety recommendations:

- Switch off the power supply before connecting the cables.
- Keep the switch away from heat sources.
- To ensure normal heat dissipation, do not stack switches.
- Do not keep the switch in a damp place, and prevent liquid from getting into the switch.
- Ensure that the neutral point of the power is grounded properly, to avoid personal injury.
- Ensure that the power is off before plugging or unplugging the modules and cables of the switch.
- Before moving the chassis, disconnect all the power cords and external cables.
- To avoid damage to the switch, connect all the cables correctly. Never connect telephone cables (including the ISDN lines) to the console or AUX port.

- During the installation, wear an antistatic wrist strap and antistatic gloves. See “Static Electricity” on page 39 for additional information on preventing static.



**WARNING:** Follow local safety regulations when performing any operation with the Switch 7750. Follow the related safety information and special safety instructions provided by 3Com. 3Com bears no responsibility for accidents that occur due to violations of safe operation requirements.

**Electrical Safety** To maintain electrical safety, note the following recommendations:

- Look carefully for possible hazards in your work area, such as ungrounded power extension cables, missing safety grounds, and moist floors.
- Locate the emergency power-off switch in the room where you are working. Shut the power off at once in the event of an accident.
- Unplug all the power cords and external cables before moving the chassis.
- Never assume that power is disconnected from a circuit. Always check.

**Moving the Switch** Use caution when moving the Switch 7750. Note the following recommendations when moving the switch:

- Do not move the switch alone. Work with another person.
- Move the switch slowly. Never move suddenly or twist your body.
- Always disconnect all external cables (including power cord) before lifting or moving the chassis.
- Do not hold the power handles when carrying the switch.
- Do not put fingers into the vent of the chassis when carrying the switch.
- Since the power handles and vent have not been designed to bear the weight of the entire chassis, using them to carry the switch may damage the switch or even injure personnel.

**Laser Safety** Some I/O modules on the Switch 7750 have optical ports. Make sure that an optical connector is connected to the optical ports, or a dust proof cover is fitted, as invisible laser radiation can be emitted from the port.



**WARNING:** Never look at the transmit LED/laser through a magnifying device while it is powered on. Never look directly at the fiber TX port and fiber cable ends when they are powered on.

---

## General Site Requirements

The environment of the installation site influences the performance and lifetime of the switch. The installation site for your switch should meet the requirements described in the following sections.

### Temperature and Humidity

To ensure normal operation and to prolong the operational lifetime of the switch, the temperature and humidity of the equipment room must be within controlled limits. The requirements for the temperature and humidity of the switch installation site are listed in Table 47.

**Table 47** Temperature and Humidity Requirements

Temperature	Relative humidity (noncondensing)
0° to 40°C (32° to 104°F)	10% to 90%

**Static Electricity**

To prevent damage caused by the static electricity, ensure that:

- The equipment is grounded
- The equipment room is dust-proof
- Adequate temperature and humidity conditions are maintained.
- The operator wears an antistatic wrist strap while handling the module.
- The module is placed upward on the antistatic workbench, or put into an antistatic bag.
- Avoid direct contact with the elements of the circuit board.

**Electromagnetic Discharge**

To prevent damage by electromagnetic discharge, do the following:

- Take effective measures against electrical interference for the power supply system.
- Separate the working ground of the switch from the grounding device of the power equipment, or lightning conductor.
- Adopt electromagnetic shielding if necessary.

**Lightning Damage**

To minimize the risk of lightning damage do the following:

- Install a lightning arrester on the input end of a telephone cable, or other external line.
- Ensure that the PGND wire of the chassis is well grounded
- Ensure that the neutral point of the socket of AC power supply is well grounded
- Install a lightning arrester at the input end of the power supply

**Installation Space**

The Switch 7750 is a complex piece of equipment so it is necessary to make arrangements for the installation position, power supply, and cabling.

For better heat dissipation and equipment maintenance, 3Com recommends that you keep the front and back of the switch more than 1 meter (3 feet) away from the walls or other devices. The sides of the switch should be at least 0.8 meters (2.5 ft) away from the walls. If the optional cabinet is installed, the clear height of room should be more than 3 meters (10 ft).

**Installation Checklist**

When you open the packing case of the switch, check the contents against the your order contract. Contact your Service representative if you find any discrepancies.

To install the Switch 7750, you will need:

- Tools
  - Phillips screwdriver
  - Flat-head screwdriver
  - Antistatic wrist strap
- Cables
  - Console cable
  - AUX cable
  - Power cord and chassis ground wire
  - Interface cables for the selected interface modules
- Equipment
  - The switch
  - Ethernet 100BASE-T Hub or LAN switch
  - Channel service unit/data service unit (CSU/DSU) or other data communications equipment (DCE) equipment (such as a modem)
  - Configuration terminal, such as a PC
  - Additional equipment for the selected interface modules

**Installing the Chassis** You can install the Switch 7750 in a standard, 19-inch cabinet or on a workbench.

**Installing in a Standard Cabinet**

When you are ready to install the Switch 7750 in the cabinet:

- 1 Carry the switch to the front of the cabinet. At least two people are required to move the switch.
- 2 Put the switch on the tray or the guides and push it into the cabinet.
- 3 Fix the switch in the cabinet with the combination screw and floating nuts that are shipped with the switch.

**Installing on a Workbench**

To install the switch on a workbench, take the following precautions:

- Ensure that the workbench is smooth and stable.
- Leave a heat-dissipation clearance in the front and back of the switch of more than 1 m (3 ft) and at least 0.8 meters (2.5 ft) away from the walls on the sides.
- Do not put heavy objects on the switch.

**Installing the Cabling Rack**

To install the cabling rack:

- 1 Attach the rack brace to the left side of the chassis (opposite the fan frame).
- 2 Insert the wiring channel into the brace and fasten the screws.



---

**Installing a Module**

To install a module:

- 1 Wear an antistatic wrist strap.
- 2 Remove the blanking plate from the chassis slot and save it for future use.
- 3 Hold the ejector levers of the module with both hands and push them outward.
- 4 Align the module with the guides in the chassis and slide it gently into the slot.
- 5 Push the module until the captive thumb screw on its handle bar touches the hole in the chassis.
- 6 Push the ejector levers inward and push the handle bar pin into the positioning hole in the chassis.
- 7 Fasten the module's captive mounting screws into the holes in the chassis with a screwdriver.

---

**Installing a Submodule**

To install a submodule in the Fabric 32 you need the following tools:

- Phillips-head screwdriver #2
- Small pliers

Do the following:

- 1 Wear an antistatic wrist strap.
- 2 Unfasten the screws on the Fabric 32 printed circuit board at locations M11 and M18.
- 3 Unfasten and remove the submodule blanking plate from the Fabric 32.
- 4 Fasten the screw with guide pin on the Fabric 32 printed circuit board at location M2.1
- 5 Fasten the four hexagonal stand-off bolts at M3, M4, M11, and M18 on the Fabric 32 printed circuit board. Do not overtighten these bolts.
- 6 Position the submodule on the four hexagonal stand-off bolts, insuring that the guide pin on the Fabric 32 matches the guide hole of the submodule.
- 7 Apply pressure near the edge connectors of the submodule to insure that the submodule connector is firmly seated.
- 8 Insert and fasten screws into the bolts that you installed in Step 5.



*To remove the submodule, reverse this procedure.*

### Connecting the Ground Wire

To connect the ground wire:

- 1 Wear an antistatic wrist strap.
- 2 Remove the screw from the grounding hole in the switch chassis.
- 3 Set the ground wire connector around the grounding screw.
- 4 Fasten the grounding screw in the hole on the chassis.
- 5 Connect the other end of the ground wire to the grounding bar of the switch.



*If you install the switch in a cabinet, 3Com recommends that the ground wire of the switch be connected to the grounding bar of the cabinet.*



**WARNING:** *The resistance between switch chassis and the ground should be less than 1 ohm.*

### Connecting and Configuring Power

The Switch 7750 requires power connection from the AC or DC power source and from the PoE power rack.

#### Connecting AC Power Cords

To connect AC power cords:

- 1 Power off all the related parts of the switch before connecting the AC power cord
- 2 Plug the power cords into the sockets in the switch and attach the retention clips to the power cord plugs.
- 3 Plug the other end of the cords into a socket strip with surge protector. Connect the strip to the power source in the room.

Figure 32 illustrates the AC power cord connection.

**Figure 32** AC Power Cord Connection

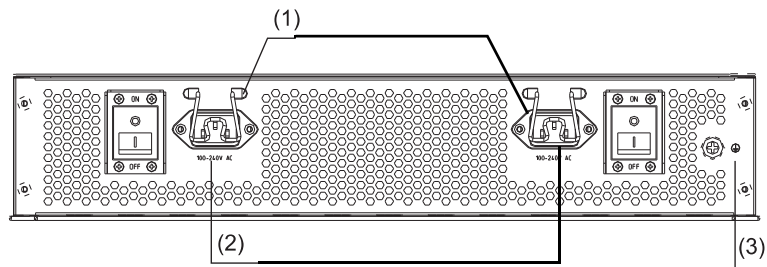

- 1 AC power sockets
- 2 Retention clips
- 3 Grounding screw



**WARNING:** *For surge protection, the power should be channelled through an external protection device into the Switch 7750.*

**Connecting DC Power Cords**

To connect DC power cords, do the following:

- 1 Power off all the related parts of the switch when connecting the DC power cord.
- 2 Loosen the mounting screw and remove the cover of the connection terminals on the DC power distribution box.
- 3 Loosen the mounting nut of the connection terminal, using a socket wrench.
- 4 Connect the -48 V terminal (with a blue wire) of the DC power cord on the switch to the terminal marked with -48 V and fasten the nut.
- 5 Connect the grounding terminal (with a black wire) of the DC power cord of the switch to the return terminal and fasten the mounting nut with socket wrench.
- 6 Cover the connection terminals and fasten the mounting screws.
- 7 Connect the other end of the DC power cord to the connection terminal for power input to the switch.

**Figure 33** Connecting the DC Power Cord

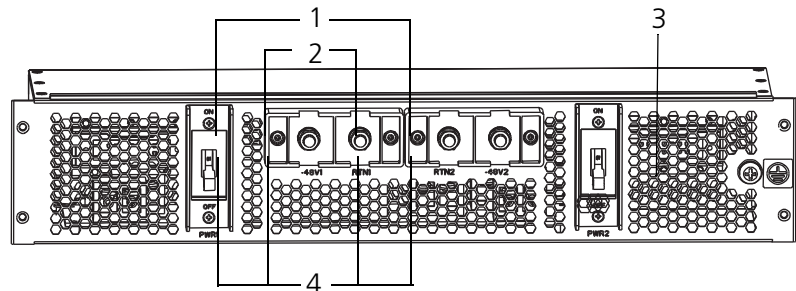

- 1 -48 V input
- 2 Return
- 3 Grounding screw
- 4 Fastening screw

**Configuring AC Power Sources**

The dual AC input power module uses an internal switch that automatically selects the primary power source. However, to select the primary power source manually, do the following:

- 1 Connect the first power cord to the AC source or backup system that you select as the primary power source for the chassis.
- 2 Power on the switch. The power module will receive power from the AC source you connected to.
- 3 Connect the second power cord to the second AC source or backup system.

If the primary AC source fails, the switch automatically fails over to the secondary AC source. There is no disruption to system operation during the power fail-over.

**Connecting the PoE Power Cord**

Follow these steps to connect the power cord from the PoE rack:

- 1 Loosen the mounting screw of the PoE terminal block on the rear panel of the switch.
- 2 Insert the -48V OT terminal of the DC power cord to the NEG (-) terminal of the switch and fasten the mounting screw; insert the other end to the NEG (-) terminal of the external PoE power supply. See Figure 34 for a detailed view.

**Figure 34** Back of the PoE Rack

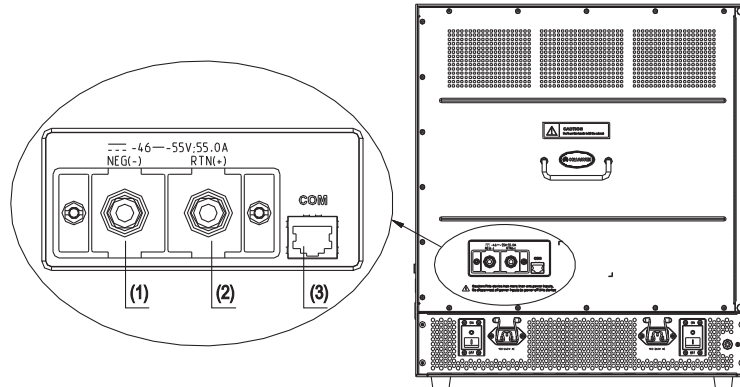

- 1 PoE external power input: NEG (-)
  - 2 (+) PoE external power input: NEG (+)
  - 3 COM port (external power monitor)
- 3 Insert the GND OT terminal of the DC power cord to the RTN (+) terminal of the switch and fasten the mounting screw; insert the other end to the NEG (-) terminal of the site power.

**Figure 35** Front Panel of the PoE Rack

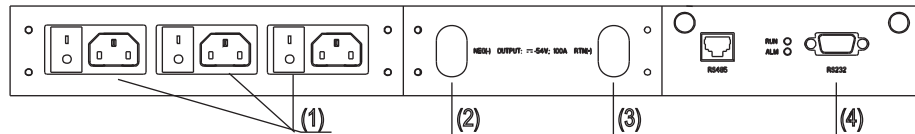

- 1 AC input socket
  - 2 DC output terminal: NEG (-)
  - 3 DC output terminal: RTN (+)
  - 4 RS232 serial port
- 4 Insert the PGND OT terminal of the DC power cord to the grounding screw of the switch and fasten the mounting screw; insert the other end to the grounding bar for the switch.

For detailed instructions on how to install the PoE rack, see the *Switch 7750 PoE Rack Installation Guide*.

---

## Installing the Fan Assembly

To install the fan:

- 1 Wear an antistatic wrist strap.
- 2 Remove the fan frame from the pack.
- 3 Hold the ejector levers on the fan frame with both hands and push them outward.
- 4 Align the fan with the guides in the chassis and slide it gently into the slot.
- 5 Push the fan until its positioning pin touches the hole in the chassis.
- 6 Push the ejector levers inward.
- 7 Push the handle bar pin into the hole in the chassis.



**WARNING:** To avoid injury, do not touch any naked wire, terminal, or any other part of the product labelled Dangerous Voltage. Always wear the antistatic wrist strap when installing the fan.

---

## Installing Cables

This section describes how to connect console and AUX cables to the Switch 7750.

### Connecting the Console Cable

The console cable is an 8-core shielded cable. One end of the cable has a crimped RJ-45 connector, which is plugged into the console port of the switch. The other end has both a DB-9-hole connector and a DB-25-hole connector for connection to a 9-hole or 25-hole serial port at the configuration terminal.

See "Console Cable" on page 77 for cable illustration and pinout details.

To connect a terminal or PC to the Switch 7750 using the console cable:

- 1 Plug the DB-9 or DB-25 female plug of the console cable to the serial port of the PC or the terminal where the switch is to be configured.
- 2 Connect the RJ-45 connector of the console cable to the console port of the switch.

### Connecting the AUX Cable

An AUX cable is used to connect the Switch 7750 to a modem in a remote dial-up configuration.

The AUX cable is an 8-core shielded cable. One end of the cable is an RS-232 RJ-45 connector, which is used to plug into the switch at the console port. The other end has both a DB-9-pin connector and a DB-25 pin for connection to a 9-hole or 25-hole serial port on the virtual modem.

See "AUX Cable" on page 77 for cable illustration and pinout details.

To connect the AUX cable:

- 1 Plug the RJ-45 end of the AUX cable into the switch console port.
- 2 Connect the DB-25 or DB-9 end of the AUX cable to the serial port of the virtual modem.

## Connecting Module Cables

This section describes how to connect electrical and optical cables.

### Connecting Electrical Port Cables

The 48-port 10/100BASE-T module and 8-port 10/100/1000BASE-T module require a RJ-45 connector and category-5 twisted pair cable. See “Electrical Port Connector” on page 78 for an illustration of the RJ-45 connector and MDI/MDI-X pinout details.

Use the following steps to connect the port:

- 1 Plug one end of the straight-through cable into the Ethernet RJ-45 port of the switch.
- 2 Plug the other end of the straight-through cable into the RJ-45 port of the hub or LAN Switch.



*Ports on 48-port 10/100BASE-T and 8-port 10/100/1000BASE-T modules support MDI/MDI-X auto-sensing.*

### Connecting Optical Fiber Cables

The following modules require fiber optic cables:

- 24-port 100BASE-FX MMF FE module
- 20-port 1000BASE-X-SFP module
- 1000BASE-SX-MM, 1000BASE-LX-SM-IR, and 1000BASE-LX-SM optional GBIC modules for the 4-port 1000BASE-X-GBIC submodule

When connecting optical fiber cables, use the fiber connectors that are appropriate for the optical port type of the peer equipment that is connected to the local network port module. See “Optical Fiber Cable Connectors” on page 79 for illustrations of the fiber optic cable connectors.

Single-mode optical fiber cable is used for external connections of the single-mode optical port. Multi-mode optical fiber cable is used for external connections of the multi-mode optical port.

Before connecting the optical fiber cable, make sure the type of the connector and the optical fiber cable are consistent with the optical port type.



**WARNING:** *When a connector is not inserted in the optical port or when its dustproof cover is open, invisible radiation can escape from the optical port. Do not stare into the optical port directly. Cover the optical port if there is no connector plugged in.*

### SC fiber connector

The 8-port 1000BASE-X GBIC module requires an SC optical fiber connector.

To attach the SC fiber connector:

- 1 Plug one end of the SC fiber connector into the optical port in the module.
- 2 Connect the other end of the connector to the corresponding device.



**CAUTION:** When connecting an SC fiber connector, the switch TX must be connected to the RX of the device on the network, and the switch RX must be connected to the TX of the device on the network.

### MT-RJ fiber connector

The 24-port 100BASE-FX MMF FE module requires an MT-RJ optical fiber connector.

To attach the MT-RJ fiber connector:

- 1 Plug the MT-RJ fiber connector in the optical port into the module.
- 2 Connect the other end of the fiber connector to the corresponding device.

## Installing Cabling

This section describes how to install and bind cables for your Switch 7750.

### Bench-Mounted Switch

If you have installed your chassis on a bench, all interface cables run on the left side of the chassis in the cabling channel, and the chassis power cords run by the rear chassis panel.

### Rack-Mounted Switch

If you have installed your switch in a 19-inch standard rack, the cables are bound on the cable binding rack at the left side of the chassis and arranged to run on the cable rack or under a raised floor. Collect all the transit data signal cable connectors and locate them on the floor of the chassis. Power cords run out of the rear left of the chassis and on a cable rack or under a raised floor.

### Cable Binding

Keep the following precautions in mind as you bind cables:

- Do not allow cables to twist or bend as you bind them.
- The cable body cannot be bent at an angle that is more than twice its diameter. The cable running out of a connector cannot be bent more than five times its diameter.
- Different types of cables (power cord, signal cable, and ground wire) should not be bound together in a cabinet. Although different types of cable may cross over each other, they must not be bound together where they cross. For parallel cabling, the space between a power cord and a signal cable should be no less than 30 mm (1.25 in).
- The cable binding rack and cable channel inside and outside a cabinet should be smooth.
- The hole through which a cable runs through should be smooth or have a rubber grommet.
- Use plastic cabling ties to bind the cables.
- Bind cables before bending them. Ensure that no tie binds the bent part of any cables to prevent the core of the cable from breaking.
- Do not tie power cables to the guides of any mobile components.
- For the cable terminals fixed with screws, the screws or nuts should be fastened securely.
- Do not use tapping screws to fasten the cabling terminals.

Follow the parameters defined in Table 48 for binding cables with ties.

**Table 48** Cable Binding Parameters

Cable Bundle Diameter	Space Between Bundles
10 mm (0.5in)	80-150 mm (3.5 – 6 in)
10-30 mm (.5 – 1.2 in)	150-200 mm (6 – 8 in)
30 mm (1.2 in)	200-300 mm (8 – 12 in)

## Post-installation Checklist

After you install your switch, use the checklist in Table 49 to verify that your switch operates correctly.



**WARNING:** *Confirm that you have turned off the power before checking your installation. Improper connections can injure people or damage components of the switch.*

**Table 49** Installation Checklist

Item	Normal	Abnormal (Remarks)
Antistatic wrist strap		
Console cable		
Ground wire		
Power cord		
Fabric		
I/O module		
Fan frame		



# 3

## CONFIGURING THE SWITCH 7750

The following sections of this chapter describe how to configure and boot the Switch 7750:

- Configuring the Switch 7750 and a Local Terminal
- Setting Terminal Parameters
- Booting the Switch 7750

---

### Configuring the Switch 7750 and a Local Terminal

Configure the local terminal and Switch 7750, using Figure 36 as a reference. The terminal (a PC in this example) is connected to the switch console port using a console cable.

**Figure 36** Connecting the Switch 7750 to a PC

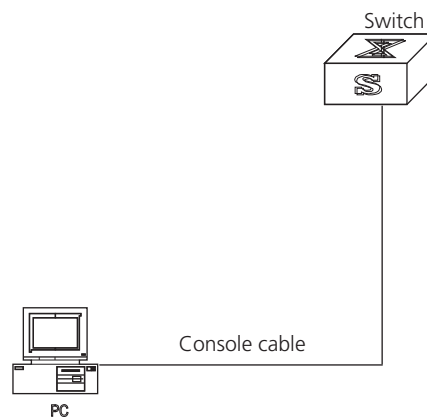

- 1 Plug the DB-9 or DB-25 female plug of the console cable into the serial port of the PC or the terminal where the switch will be configured.
- 2 Connect the RJ-45 connector of the console cable to the console port of the switch.

---

### Setting Terminal Parameters

To set terminal parameters and open a HyperTerminal session:

- 1 Start the PC and select *Start > Programs > Accessories > Communications > HyperTerminal*.

The *Connection Description* dialog box displays, as shown in Figure 37.

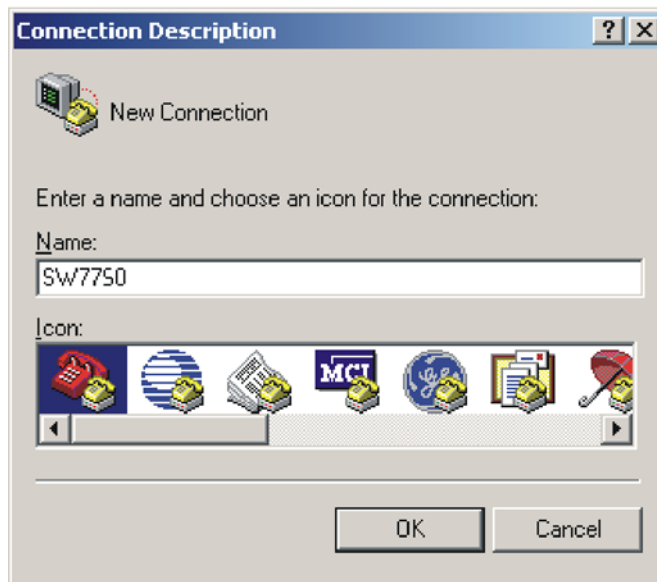
**Figure 37** Connection Description Dialog Box

- 2 Enter the name of the new connection in the *Name* field and click *OK*. The dialog box, shown in Figure 38 displays. Select the serial port to be used from the *Connect using* dropdown menu.

**Figure 38** Properties Dialog Box

- 3 After selecting serial ports, click *OK*. The port shown in Figure 39 displays and you can set serial port parameters. Set the following parameters:
  - Baud rate = 9600
  - Databit = 8
  - Parity check = none
  - Stopbit = 1
  - Flow control = none

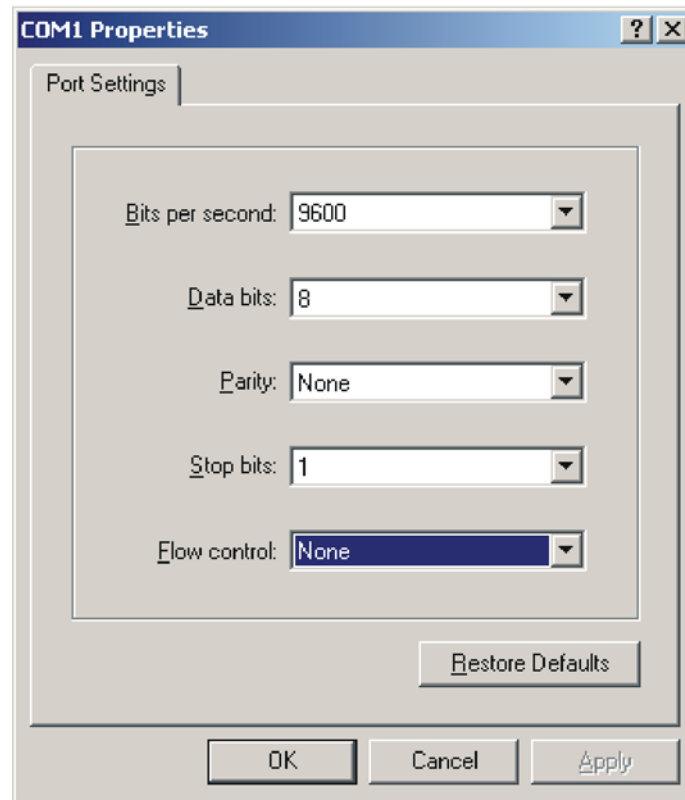
**Figure 39** COM1 Properties Dialog Box

- 4 Click *OK*. The HyperTerminal dialogue box displays, as shown in Figure 40.

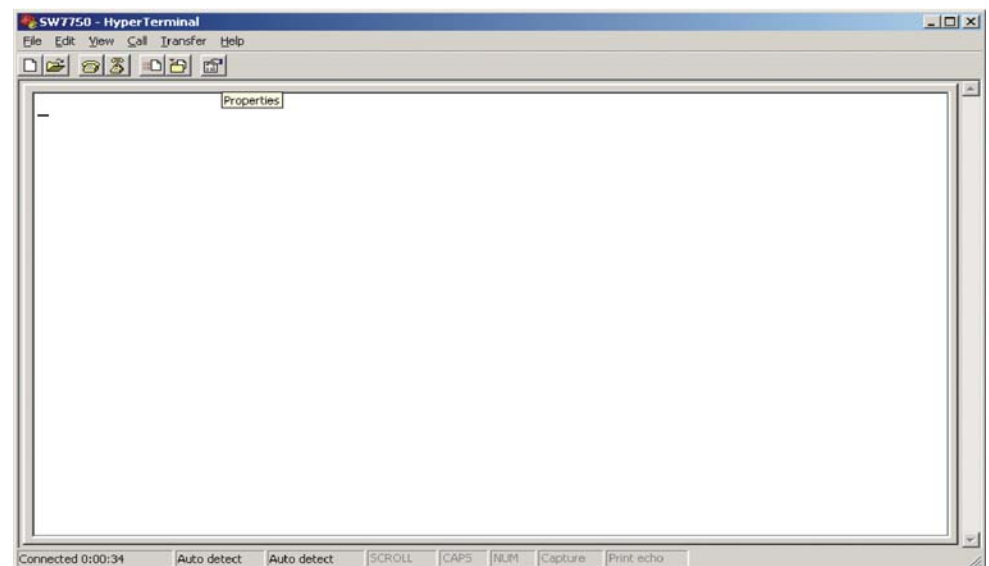
**Figure 40** HyperTerminal Window

- 5 Select *Properties*.
- 6 In the Properties dialog box, select the *Settings* tab, shown in Figure 41.
- 7 Select *VT100* in the *Emulation* dropdown menu.
- 8 Click *OK*.

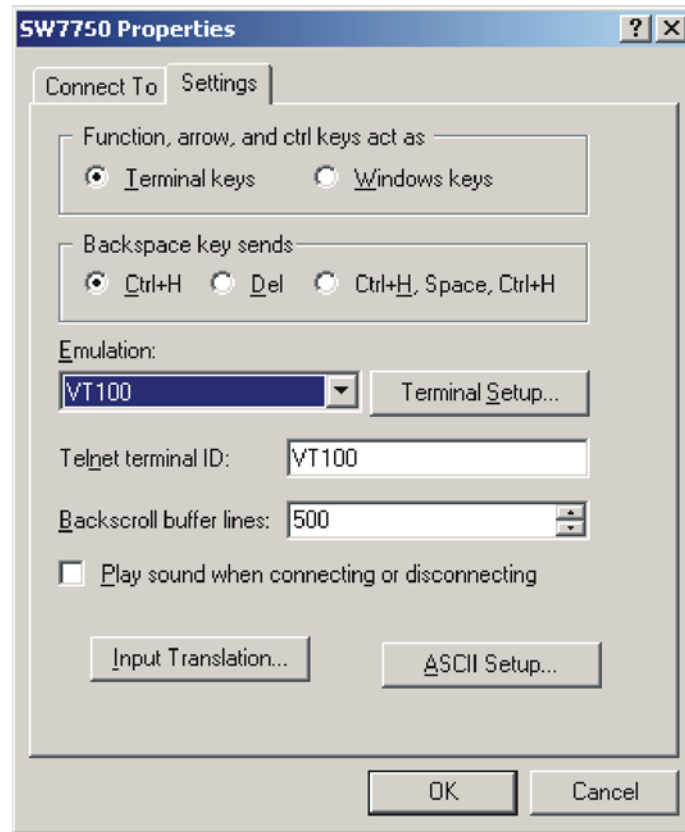
**Figure 41** Settings Tab

## Booting the Switch 7750

Before powering on the Switch 7750, verify that:

- Power cords have been properly connected.
- The voltage of power supply can meet the requirements on the switch.
- The console cable has been connected properly.
- The PC or terminal for configuration has been started.
- The terminal parameters have been set.

**Powering up and Booting**

Turn on the power for the Switch 7750 and run the BootROM program. The terminal displays the following information:

```
Starting.....
RAM Line...OK
System is booting.....
```

```
*****
*
* Switch 7750 BOOTROM, Version 300 *
*
*****
```

```
Copyright(C) 2001-2005 by 3Com Corporation, Inc.
Creation date: Mar 25 2003, 09:33:05
CPU type      : MPC8260
CPU Clock Speed : 200Mhz
BUS Clock Speed : 66Mhz
Memory Size   : 256MB
```

```
FAB64 self testing.....
60X_SDRAM Data lines Selftest.....OK!
60X_SDRAM Address lines Selftest.....OK!
60X_SDRAM fast selftest.....OK!
Please check LEDs.....LEDs selftest finished!
Switch chip selftest.....OK!
CPLD selftest.....OK!
The switch Mac address is .....00E0.FC00.7505
```

Press Ctrl+B to enter Boot Menu... 5



*To enter Boot Mode (see Chapter 6), press Ctrl+B during the 5 seconds that "Press Ctrl+B to enter Boot Menu...5" is displayed. To perform decompression immediately, press ESC while this message is displayed. If you do nothing, the system enters the following auto-booting port within 5 seconds:*

```
Auto-booting.....
Auto booting file is sw7750001.app
There are 2 files in this packet
FAB64 app file <<FAB64001.app>> is...OK
Decompress
Image.....
.....
.....
.....
.....OK!
Starting at 0x60000...
```

User interface Aux0 is available

The display of these messages indicates the completion of the switch auto-booting. Press *Enter* and the terminal screen displays:

```
<3Com>
```

You can now begin the configuration for the Switch 7750.

# 4

## MAINTAINING SOFTWARE

This chapter covers the following topics:

- Upgrading Software
- Lost Passwords
- Using the BOOT Menu

---

### Upgrading Software

The following sections describe how to upgrade software on your Switch 7750:

- Upgrading the Software Image
- Upgrading Software with FTP
- Upgrading Software Using The BOOT Menu
- Upgrading Software Using Xmodem
- Upgrading Software Using TFTP
- Upgrading Software in the Secondary Fabric of the 8-slot Chassis



*Always save the configuration file before upgrading applications.*

### Upgrading the Software Image

To upgrade the software image of a Switch 7750, use one of the following procedures:

- “Upgrading Software with FTP” on page 55
- “Upgrading Software Using The BOOT Menu” page 56
- “Upgrading Software Using Xmodem” page 60
- “Upgrading Software Using TFTP” page 62

### Upgrading Software with FTP

Use the following procedure to upgrade software with FTP:

- 1 Log in to the system with super-user privileges.
- 2 From the SW7750 command line, transfer the file from the FTP server to the system, using the `ftp` command.
- 3 Specify the file to boot the system from, using the `boot` command.
- 4 Reboot the system, using the `reboot` command.

The following example illustrates this procedure:

```
<SW7750>su  
Password:
```

```
Now user privilege is 3 level, and just commands which level is  
equal to or less than this level can be used.
```

```

Privilege note: 0-VISIT, 1-MONITOR, 2-SYSTEM, 3-MANAGE
<SW7750>ftp 10.10.110.1
Trying ...
Press CTRL+K to abort
Connected.
220 3Com 3CDaemon FTP Server Version 2.0
User(none):anonymous
331 User name ok, need password
Password: xxxxxxx
230 User logged in

[ftp]bin
200 Type set to I.

[ftp]get sw7750003.app
200 PORT command successful.
150 File status OK ; about to open data connection
226 Closing data connection; File transfer successful.
FTP: 3794803 byte(s) received in 130.480 second(s)
29.08Kbyte(s)/sec.

[ftp]quit
221 Service closing control connection

<SW7750>boot boot-loader primary sw7750003.app
The specified file will be booted next time!
<SW7750>reboot
This will reboot Switch. Continue? [Y/N] y

```

For more detailed descriptions of the setup and procedures for upgrading software, see the remaining sections in this chapter.

### Upgrading Software Using The BOOT Menu

To perform this procedure, you must have a network connection to the management port on the Switch 7750 Fabric module.

After powering on the Switch 7750, the BootROM program runs automatically. The terminal displays the following information:

```

Starting.....
RAMLine.....OK
System is booting.....

*****
*                               *
*   Switch 7750 BOOTROM, Version 516   *
*                               *
*****

Copyright (c)   : 2003-2005 3Com Corporation
Creation date   : Jan 20 2005, 09:37:12
CPU type       : MPC8245
CPU Clock Speed : 400Mhz
BUS Clock Speed : 66Mhz
BOOT_FLASH type : M29W040B
Flash Size     : 32MB
Memory Size    : 256MB

```



```
FAB96 self testing.....
SDRAM Data lines Selftest.....OK!
SDRAM Address lines Selftest.....OK!
SDRAM fast selftest.....OK!
Please check LEDs.....LEDs selftest finished!
CPLD selftest.....OK!
FPGA selftest.....OK!
The switch Mac address is .....0020.4C6A.CF04
```

Press Ctrl+B to enter Boot Menu...

- 1 Press *Ctrl+B*. The system displays the prompt for the BootROM password:

Password :



*To access the BOOT Menu, press Ctrl+B during the five seconds that "Press Ctrl-B to enter Boot Menu..." displays. After five seconds, the system begins program decompression. If you want to access the BOOT Menu after this, you must reboot the switch.*

- 2 Enter the BootROM password. After entering the correct password (no password is set for the switch by default), the system will access the BOOT Menu:



**CAUTION:** *While using the switch, keep in mind the modified BOOTROM password.*

```
Boot Menu
1: Download application file to flash
2: Select application file to boot
3: Display all files in flash
4: Delete file from flash
5: Modify bootrom password
0: Reboot
Enter your choice(0-5):
```

### Downloading an Application to Flash Memory

To download an application to flash memory:

- 1 Select option **1** on the Boot Menu. The following menu displays:
 

```
1. Set TFTP protocol parameter
2. Set FTP protocol parameter
3. Set XMODEM protocol parameter
0. Return to boot menu
Enter your choice(0-3): 1
```
- 2 Select option **1** then enter the appropriate information in the fields that display:
 

```
Load File name           :sw7750003.app
Switch IP address        :10.10.110.1
Server IP address        :10.10.110.50
```
- 3 Type **Y** at the download prompt so the system downloads the file to flash:
 

```
Are you sure to download file to flash? Yes or No(Y/N) y
```
- 4 After the download is complete, select option **0** to return to the boot menu.
- 5 From the boot menu, select option **2** then select the newly downloaded file.

### Selecting the Application File for the Boot

If the Switch 7750 primary image fails because of a CRC error or a file format error, you can configure the system to find the backup image you select to boot from.

To select the image file that you want the system to boot from:

- 1 Select **0** to return to the Boot Menu.
- 2 Select option **2** from the Boot Menu. The following text displays:

```
File Number           File Size (bytes)      File Name
=====
1.                    4                      snmpboots
2 (-) .              6256229                SW7750-V300RE-8016.app
3.                    1012                   taskswitch.log
4.                    151                    private-data.txt
5.                    228308                 s.t
6.                    1975                   sw7750.cfg
7.                    631736                 Btm400.btm
8 (*) .              462848                 SW7750-V300R-.app
9.                    228376                 S3com400.app
10.                   199696                 8241btm.app
11.                   2427                   vrpcfg.txt
12.                   203460                 lpcom400.app
13.                   228308                 snec400.app
```

The current application file is :SW7750-V300R-.app

The backup application file is :SW7750-V300RE-8016.app

Free Space : 7536640 bytes

- 3 Enter the file number of the primary image:

Please input the primary image file number : **13**

- 4 To confirm this choice, type **Y** at the prompt:

The primary file you selected is snec400.app, are you sure? Yes or No (Y/N) **Y**

On reboot, snec400.app will become the default application file to boot!

- 5 Enter the file number of the backup image:

Please input the backup image file number : **8**

- 6 To confirm this choice, type **Y** at the prompt:

The file you selected is SW7750-V300R-.app, are you sure? Yes or No(Y/N) **y**

On reboot,SW7750-V300R-.app will become the default application file to boot!

## 7 Type Y to run the primary image:

Do you want to run snec400.app now? Yes or No(Y/N)? **Y**

**No Backup Image** If you do not enter the number of a backup boot file, the following text displays:

Please input the backup boot file number :

Input Error!

Failed to select backup image file!

Type Y to run the primary boot file:

Do you want to run snec400.app now? Yes or No(Y/N)? **Y**

**Backup Image Fails** If the backup image fails and another backup image configuration does not exist, the Switch 7750 will try to find any valid image on the flash. This image is not the primary or backup image:

**All Images Fail** If all images fail, the Switch 7750 will return to the boot menu:

primary image : snec400.app

backup image : SW7750-V300R-.app

There is one passed image in addition:

File Number	File Size(bytes)	File Name
=====		
1.	6256229	SW7750-V300RE-8016.app

Press Ctrl+B to enter Boot Menu... 0

Auto-booting.....

Auto booting file is snec400.app

No LPU application file < vxworks.app > in flash

Please download LPU application file vxworks.app to flash

No correct main file to boot!

loading backup image file to boot!

Auto booting backup file is SW7750-V300R-.app

```

Assert at file: 'vfs_flsh.c', Line: 4549

There are 3 files in this package

SRPU app file error! backup boot file is corrupted!

Select a file to boot from!

the num is 1

the num is 2

File SW7750-V300RE-8016.app is selected for autoBoot:

    backup file is SW7750-V300RE-8016.app

There are 3 files in this package

SRPU app file <<FAB64R.app>> is...OK

Decompress
Image.....
.....
.....
.....
.....
.....OK!

```



Starting at 0x60000...

*The primary image name is saved in flash memory, the secondary image name is saved in the EPPROM. However, if you use the **display boot** command to display the boot image it will only read from flash so only the primary image will be displayed. The secondary boot image name cannot be displayed when there is an image error.*

**Upgrading Software  
Using Xmodem**

The Xmodem protocol transmits files through serial ports and supports both 128-byte and 1K-byte packets. Xmodem also supports two types of check; normal checksum and CRC. When there is a packet error, retransmission is supported, normally 10 times.

The Xmodem protocol completes transmission by receiving and sending programs. The receiving program first sends the negotiating characters to negotiate the check means. After passing the negotiation, the sending program begins to send the packet.

The receiving program checks the packet according to the negotiated means after receiving a complete packet. The acknowledgement characters are sent after passing the check and then the sending program continues to send the next

packet. If the check fails, negative characters are sent and the sending program sends the packet again.

- 1 Enter **1** in the BOOT Menu and press *Enter*. The system accesses the download application file menu:

```
1. Set TFTP protocol parameter
2. Set FTP protocol parameter
3. Set XMODEM protocol parameter
0. Return to boot menu
Enter your choice (0-3):
```

- 2 Enter **3** in the download program menu.

```
Enter your choice(0-3): 3
```

- 3 Press *Enter*. The system enters the download rate-setting menu:

```
Please select your download baudrate:
1. 9600
2. 19200
3. 38400
4. 57600
5. 115200
0. Exit
Enter your choice (0-5):
```

- 4 Select the appropriate download speed. For example, enter **5** to select a download speed of 115200bps.

- 5 Press *Enter*. The terminal displays the following information:

```
Download baudrate is 115200 bps. Please change the terminal's
baudrate to 115200 bps, and select XMODEM protocol.
Press enter key when ready.
```

- 6 Change the baud rate set at the configuration terminal, so that the baud rate is consistent with the selected download baud rate of the software.

- 7 Disconnect the terminal and reconnect it.

- 8 Press *Enter* to start downloading. The terminal displays the following information:

```
Now please start transfer file with XMODEM protocol.
If you want to exit, Press <Ctrl+X>.
Waiting ... CCCCC
```

- 9 Select *Transfer\Send File* from the terminal window.

- 10 Click *Browse* in the Send file dialog box, shown in Figure 42 and select the application you want to download.

**Figure 42** Send File dialog box

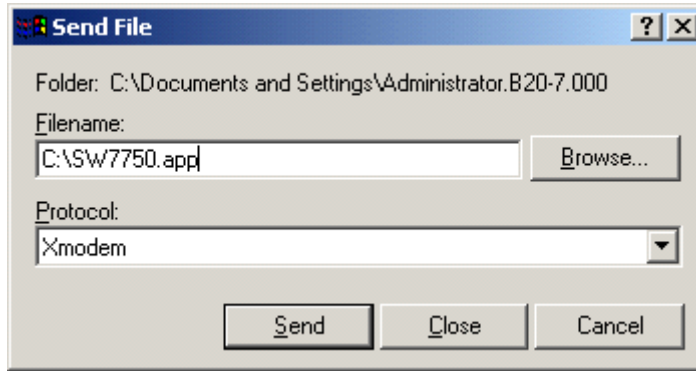

- 11 Change the protocol name for the download to *Xmodem*.
- 12 Click *Send*. The dialog box shown in Figure 43 displays.

**Figure 43** Xmodem File Send Dialog Box

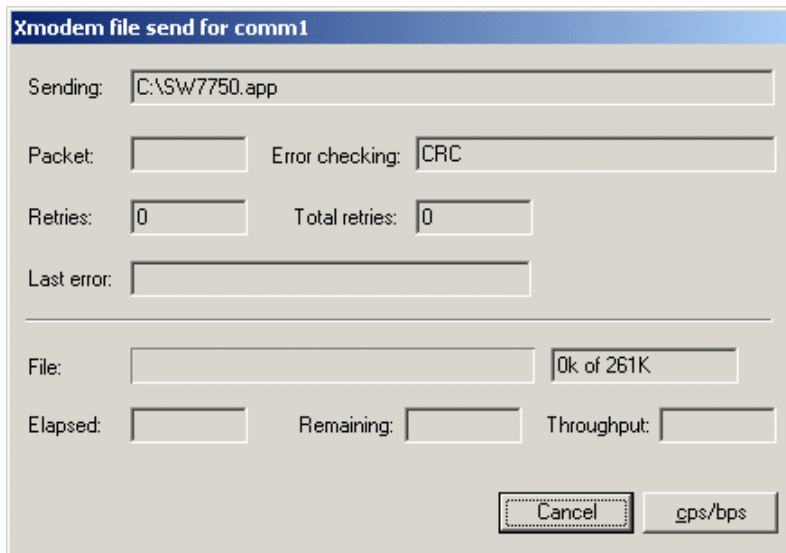

- 13 After the download is complete, the system interface is shown, as follows:  
Loading ...cc done!
- 14 Select *0* to return to the Boot Menu.
- 15 From the boot menu, select option *2* then select the newly downloaded file.

**Upgrading Software Using TFTP**

TFTP (Trivial File Transfer Protocol) is a simple file transfer protocol that is used without complex interaction between clients and servers.

The client initiates a TFTP transmission. To download files, the client sends a read request packet to the TFTP server, receives the packet from the server, and sends the acknowledgement to the server. To upload files, the client sends a write request packet to the TFTP server, sends the data packet to the server, and receives the acknowledgement from the server.

The Switch 7750 provides the functions of the TFTP client.



A TFTP Server program is shipped on the CDROM with the Switch 7750.

Before you upgrade:

- Verify that there is a connection between the TFTP server and the Switch 7750 (use the `ping` command.)
- Verify that the TFTP server is set up according to the manufacturer's instructions and that it is enabled and pointing to the correct directory.

To upgrade using TFTP:

- 1 Verify that you are logged in with super-user privileges.
- 2 From the Switch 7750 command line (in user view), TFTP the image file from the TFTP server to the Switch 7750 using the following command:

```
tftp <TFTP Server IP Address> get <Source File/image>< Dest
File-Optional>
```

- 3 Set the boot parameters to specify the file to boot the system from, using the following command:

```
boot boot-loader primary filename
```

- 4 Reboot the system.

The following example illustrates this procedure:

```
<SW7750>tftp 10.10.110.1 get sw7750003.app
Transfer file in binary mode.
Now begin to download file from remote tftp server, please wait...
/
TFTP: 5690749 bytes received in 376 second(s).
File downloaded successfully.

<SW7750>boot boot-loader primary sw7750003.app
The specified file will be booted next time!
<SW7750>reboot
This command will reboot the system. Continue? [Y/N] y
```

### Upgrading Software in the Secondary Fabric of the 8-slot Chassis

After you have upgraded the software on the primary Fabric in an 8-slot chassis, you must copy the software to the secondary Fabric.

- 1 Copy the code to the secondary Fabric.
 

```
<SW-7700-8-slot>copy slot0#flash:/77h03_01_51s56c10.app slot1#flash
```
- 2 Set the boot-loader to boot off from the new application image after the next reboot.

```
<SW-7700-8-slot>boot boot-loader primary
slot1#flash:/77h03_01_51s56c10.app slot1#flash
```

---

### Lost Passwords

If the BootROM password of the switch is lost, contact your local support center, listed in Appendix B.

---

### Using the BOOT Menu

After you power on the Switch 7750, the BootROM program runs automatically. The terminal displays the following information:

```

Starting.....
RAMLine.....OK
System is booting.....

*****
*
*   Switch 7750 BOOTROM, Version 516   *
*
*****

Copyright (c)   : 2003-2005 3Com Corporation
Creation date   : Jan 20 2005, 09:37:12
CPU type        : MPC8245
CPU Clock Speed : 400Mhz
BUS Clock Speed : 66Mhz
BOOT_FLASH type : M29W040B
Flash Size     : 32MB
Memory Size    : 256MB

FAB96 self testing.....
SDRAM Data lines Selftest.....OK!
SDRAM Address lines Selftest.....OK!
SDRAM fast selftest.....OK!
Please check LEDs.....LEDs selftest finished!
CPLD selftest.....OK!
FPGA selftest.....OK!
The switch Mac address is .....0020.4C6A.CF04

Press Ctrl+B to enter Boot Menu...

```



*The contents displayed on the terminal can vary with different versions of Boot ROM.*

If you press *Ctrl+B* immediately, the system displays the Boot Menu. If you do not press *Ctrl+B*, the system initiates the program decompression process. At this time if you want to access the BOOT Menu, you must reboot the switch.

Press *Ctrl+B*. The system displays:

```

Initialize flash file system. Please wait!
Password :

```

Enter the BootROM password. After entering the correct password (no password is set for the switch by default), the system will access the BOOT Menu:

```

Boot Menu
1: Download application file to flash
2: Select application file to boot
3: Display all files in flash
4: Delete file from flash
5: Modify bootrom password
0: Reboot
Enter your choice(0-5):

```





**CAUTION:** While using the switch, please keep in mind the modified BOOTROM password.



# 5

## TROUBLESHOOTING

This chapter covers the following topics:

- Troubleshooting the Configuration
- Troubleshooting Power
- Troubleshooting the Fan
- Troubleshooting the Modules

The simplest way to diagnose a fault is to check the system status LEDs on the Fabric modules. In addition, with the DeviceMgr network management system, you can also locate the fault through management software.

---

### Troubleshooting the Configuration

After the switch is powered on, booting information is displayed on the configuration terminal. If the configuration system has failed, there is no screen display at the configuration terminal or the displayed characters are illegible.

#### No information is displayed on the terminal

If there is no information displayed on the terminal after the Switch 7750 is powered on, check that:

- The power system is working normally.
- The Fabric is working normally.
- The console cable has been connected to the console port in the Fabric.

If this procedure does not reveal the problem, verify that the console cable is properly connected and that the configuration terminal is set correctly.

#### The display characters are illegible

If the displayed characters are illegible, the parameters of configuration terminal may not have been set correctly. See Setting Terminal Parameters on page 49.

---

### Troubleshooting Power

If the Power OK LED is off, there may be something wrong with the system power supply. Check that:

- The power module has been installed in the correct position to ensure normal communication with the backplane.
- The switch power has been turned on.
- The power cord is connected properly.
- The source voltage is correct.

Table 50 describes power LEDs on the Fabric. (continued)

**Table 50** Power LEDs on the Fabric

LED	Status Description
OK	On — The power is working normally. Off — The power has failed or has not been installed.
FAIL	On — The power has failed. Off — The power is working normally or has not been installed.

## Troubleshooting the Fan

If the fan OK LED is off, check that:

- The fan has been installed in the correct position for normal communication with the backplane.
- Every heat dissipation fan is working normally.
- There is nothing blocking the vent of the chassis.
- The blanking plates are installed on the chassis where no module is inserted.

Table 51 describes fan LEDs on the Fabric.

**Table 51** Fan LEDs on the Fabric

LED	Status Description
OK	On — The fan is working normally. Off — The fan has failed or has not been installed.
FAIL	On — The fan has failed. Off — The fan is working or has not been installed

## Troubleshooting the Modules

The Fabric and I/O module LEDs show the status of the FABRIC and the I/O modules, as described in Table 52.

- If the ALM LED of the module remains green or green flashing, it indicates there is something wrong with the module.
- During the process of resetting the module, the ALM LED remains on. After normal booting, it is off.
- When resetting the module, if the ALM LED remains off, the module may not be connected to the power source. Verify that the module has been properly installed in the correct position.

**Table 52** Module LEDs on the Fabric

LED	Status Description
RUN	Green/Off — The module has failed or has not been inserted. Green flashing — The module is working normally.
ALM	Off — The module is working or has not been inserted. Green or green flashing— The module has failed.

# 6

## MAINTAINING HARDWARE

This chapter covers the following topics:

- Replacing a Power Module
- Replacing a Power Supply
- Replacing I/O Modules
- Replacing the Fan Assembly



*The procedures in this chapter should be performed by trained service personnel only.*

---

### Replacing a Power Module

To replace a power module, you need:

- An antistatic wrist strap
- A screwdriver



**WARNING:** *Insure that the switch is powered off before removing or installing a power module.*

### Removing the AC Power Module

To remove the power module, do the following:

- 1 Power off the Switch 7750.
- 2 Remove the power cord from both the power module and the AC power socket.
- 3 Loosen the retaining screw that secures the power supply on the lower right front of the power supply.
- 4 Remove the power supplies approximately 2 inches (5 cm) from the chassis to disconnect the power supply AC connectors from the AC power module.
- 5 Loosen and remove the 4 screws at the corners of the power module.
- 6 Remove the power module from the chassis.

### Installing the AC Power Module

To install the new power module, do the following:

- 1 Slide the replacement power module into the power module slot in the bottom rear of the chassis.
- 2 Insert and tighten the 4 screws at the corners of the power module.
- 3 Reconnect the power supplies to the power module.
- 4 Tighten the retaining screw on the lower right front of the power supply.
- 5 Connect 2 power cords to the power module.

- 6 Connect the power cords to separate AC power sources on separate power grids or to a UPS/backup power system.



**WARNING:** Do not power on the switch until you reconnect all the components.

## Replacing a Power Supply

To replace a power supply, you need:

- An antistatic wrist strap
- A screwdriver



**WARNING:** When installing or replacing the power supply when the power is on, do not touch any naked wire, terminal, or any other part of the product labeled Dangerous Voltage. Always wear the antistatic wrist strap when replacing the supply.

Use the following steps to replace a power supply:

- 1 Loosen the captive screws in the supply that you want to replace.
- 2 Support the power supply you are removing with one hand and gently pull the handle with the other hand until it slides out of the slot.
- 3 If you are not going to install another power supply in this slot, install a blanking plate on the chassis for dust-proofing and heat dissipation.
- 4 Remove the new power supply from the package and check the input mode.
- 5 Support the power supply in one hand and hold the handle with another hand. Align the supply with the guides in the chassis and slide the supply gently into the slot.



**CAUTION:** As you are inserting the power supply, if the pin terminal springs up, the pin cannot be seated into the hole and the system will sound an alarm. If the power supply has not been inserted properly, you should slide it out and insert it again to avoid breaking or cracking the power terminals.

- 6 Fasten the captive screws.



**CAUTION:** If the captive screws cannot be fastened, the power supply may not have been properly seated. Remove and replace the supply.

Over time, the filter on the power supply accumulates dust, which interferes with the heat dissipation of the chassis. It is important to periodically clean the filter as described below:

- 1 Remove the gauze filter by gently pulling it from the front of the power supply.
- 2 Take the filter to a fresh water supply and clean it.
- 3 Leave the filter to dry. Do not use heat to dry the filter as this may cause it to distort.
- 4 When the filter is completely dry, gently push it back into the front of the power module.



**CAUTION:** Do not clean the filter while it is in position at the front of the power supply. Attempts to do so could result in damage to the equipment or severe electrical shock.

---

**Replacing I/O Modules** To replace an I/O module, you need:

- An antistatic wrist strap
- A Screwdriver

To remove a module:

- 1 Remove all the cables from the module to be removed.
- 2 Loosen the captive screws.
- 3 Hold the ejector levers on the module with both hands, and press them toward both sides to separate the connectors of the module from the motherboard.
- 4 Gently slide the module along the guides and out of the slot.
- 5 Put the removed module into the package that contained the replacement module.



*Replace the blanking plate on the chassis if you do not install a new module in the place where the old one was removed.*

To install a replacement module:

- 1 With both hands, hold the ejector levers on the module that will be installed.
- 2 Align the module with the guides in the chassis and slide it into the slot gently until you feel the positioning pin on the handle bar touch the hole in the chassis.
- 3 Press the ejector levers inward and seat the pin on the handle bar into the positioning hole in the chassis.
- 4 Fasten the captive screws to fix the module.

---

## Replacing the Fan Assembly

You can hot-swap fan assemblies in the Switch 7750.

To replace a fan assembly, you need:

- An antistatic wrist strap
- A Screwdriver



**WARNING:** *To avoid injury, do not touch any naked wire, terminal, or any part of the product labeled Dangerous Voltage. Always wear the antistatic wrist strap when replacing the fan module.*

To replace a fan assembly:

- 1 Put on the antistatic wrist strap.
- 2 With both hands, pull out the ejector levers on the fan assembly to separate the fan assembly connector from the backplane.
- 3 Pull the fan gently along the guides of the slot to remove it.
- 4 With both hands, pull out the ejector levers of the fan that will be installed. Align it with the guides in the chassis and slide it gently into the slot until you feel the positioning pin on the handle bar touch the hole in the chassis.
- 5 Press the ejector levers inward and seat the pin on the handle bar into the positioning hole in the chassis.



**WARNING:** *If the fan fails, replace it with a new one without delay before operating the Switch 7750. Failure to do so will cause the switch to overheat.*



# B

## OBTAINING SUPPORT FOR YOUR SWITCH

---

### Register Your Product to Gain Service Benefits

To take advantage of warranty and other service benefits, you must first register your product at <http://eSupport.3com.com/>. 3Com eSupport services are based on accounts that you create or have authorization to access. First time users must apply for a user name and password that provides access to a number of eSupport features including Product Registration, Repair Services, and Service Request.

---

### Purchase Value-Added Services

To enhance response times or extend warranty benefits, contact 3Com or your authorized 3Com reseller. Value-added services can include 24x7 telephone technical support, software upgrades, onsite assistance or advance hardware replacement. Experienced engineers are available to manage your installation with minimal disruption to your network. Expert assessment and implementation services are offered to fill resource gaps and ensure the success of your networking projects. More information on 3Com Extended Warranty and Professional Services is available at <http://www.3com.com/>

Contact your authorized 3Com reseller or 3Com for additional product and support information.

---

### Troubleshoot Online

You will find support tools posted on the 3Com web site at <http://www.3com.com/>

- **3Com Knowledgebase** helps you troubleshoot 3Com products. This query-based interactive tool is located at <http://knowledgebase.3com.com> and contains thousands of technical solutions written by 3Com support engineers.
- **Connection Assistant** helps you install, configure and troubleshoot 3Com desktop and server NICs, wireless cards and Bluetooth devices. This diagnostic software is located at:  
[http://www.3com.com/prodforms/software/connection\\_assistant/ca\\_thankyou.html](http://www.3com.com/prodforms/software/connection_assistant/ca_thankyou.html)

---

### Access Software Downloads

**Software Updates** are the bug fix / maintenance releases for the version of software initially purchased with the product. In order to access these Software Updates you must first register your product on the 3Com web site at <http://eSupport.3com.com/>.

First time users will need to apply for a user name and password. A link to software downloads can be found at <http://eSupport.3com.com/>, or under the Product Support heading at <http://www.3com.com/>.

**Software Upgrades** are the software releases that follow the software version included with your original product. In order to access upgrades and related documentation you must first purchase a service contract from 3Com or your reseller.

**Contact Us**

3Com offers telephone, e-mail and internet access to technical support and repair services. To access these services for your region, use the appropriate telephone number, URL or e-mail address from the list below. You will find a current directory of support telephone numbers posted on the 3Com web site at <http://csoweb4.3com.com/contactus/>

**Telephone Technical Support and Repair**

To obtain telephone support as part of your warranty and other service benefits, you must first register your product at <http://eSupport.3com.com/>

When you contact 3Com for assistance, please have the following information ready:

- Product model name, part number, and serial number
- A list of system hardware and software, including revision level
- Diagnostic error messages
- Details about recent configuration changes, if applicable

To send a product directly to 3Com for repair, you must first obtain a return authorization number (RMA). Products sent to 3Com, without authorization numbers clearly marked on the outside of the package, will be returned to the sender unopened, at the sender's expense. If your product is registered and under warranty, you can obtain an RMA number online at <http://eSupport.3com.com/>. First time users will need to apply for a user name and password.

Telephone numbers are correct at the time of publication. Find a current directory of support telephone numbers posted on the 3Com web site at <http://csoweb4.3com.com/contactus/>

Country	Telephone Number	Country	Telephone Number
<b>Asia, Pacific Rim Telephone Technical Support and Repair</b>			
Australia	1 800 678 515	Philippines	1235 61 266 2602 or
Hong Kong	800 933 486		1800 1 888 9469
India	+61 2 9424 5179 or	P.R. of China	10800 61 00137 or
	000800 650 1111		021 6350 1590 or
Indonesia	001 803 61009		00800 0638 3266
Japan	00531 616 439 or	Singapore	800 6161 463
	03 5977 7991	S. Korea	080 333 3308
Malaysia	1800 801 777	Taiwan	00801 611 261
New Zealand	0800 446 398	Thailand	001 800 611 2000
Pakistan	+61 2 9937 5083		

You can also obtain support in this region using the following e-mail: [apr\\_technical\\_support@3com.com](mailto:apr_technical_support@3com.com)

Or request a repair authorization number (RMA) by fax using this number: + 65 543 6348

Country	Telephone Number	Country	Telephone Number
---------	------------------	---------	------------------

### Europe, Middle East, and Africa Telephone Technical Support and Repair

From anywhere in these regions, call: +44 (0)1442 435529

From the following countries, you may use the numbers shown:

Austria	01 7956 7124	Luxembourg	342 0808128
Belgium	070 700 770	Netherlands	0900 777 7737
Denmark	7010 7289	Norway	815 33 047
Finland	01080 2783	Poland	00800 441 1357
France	0825 809 622	Portugal	707 200 123
Germany	01805 404 747	South Africa	0800 995 014
Hungary	06800 12813	Spain	9 021 60455
Ireland	01407 3387	Sweden	07711 14453
Israel	1800 945 3794	Switzerland	08488 50112
Italy	199 161346	U.K.	0870 241 3901

You can also obtain support in this region using the following URL: <http://emea.3com.com/support/email.html>

### Latin America Telephone Technical Support and Repair

Antigua	1 800 988 2112	Guatemala	AT&T +800 998 2112
Argentina	0 810 444 3COM	Haiti	57 1 657 0888
Aruba	1 800 998 2112	Honduras	AT&T +800 998 2112
Bahamas	1 800 998 2112	Jamaica	1 800 998 2112
Barbados	1 800 998 2112	Martinique	571 657 0888
Belize	52 5 201 0010	Mexico	01 800 849CARE
Bermuda	1 800 998 2112	Nicaragua	AT&T +800 998 2112
Bonaire	1 800 998 2112	Panama	AT&T +800 998 2112
Brazil	0800 13 3COM	Paraguay	54 11 4894 1888
Cayman	1 800 998 2112	Peru	AT&T +800 998 2112
Chile	AT&T +800 998 2112	Puerto Rico	1 800 998 2112
Colombia	AT&T +800 998 2112	Salvador	AT&T +800 998 2112
Costa Rica	AT&T +800 998 2112	Trinidad and Tobago	1 800 998 2112
Curacao	1 800 998 2112	Uruguay	AT&T +800 998 2112
Ecuador	AT&T +800 998 2112	Venezuela	AT&T +800 998 2112
Dominican Republic	AT&T +800 998 2112	Virgin Islands	57 1 657 0888

You can also obtain support in this region using the following:

Spanish speakers, enter the URL:

<http://lat.3com.com/lat/support/form.html>

Portuguese speakers, enter the URL:

<http://lat.3com.com/br/support/form.html>

English speakers in Latin America should send e-mail to:

[lat\\_support\\_anc@3com.com](mailto:lat_support_anc@3com.com)

### US and Canada Telephone Technical Support and Repair

1 800 876 3266



# A

## SWITCH 7750 CABLES

This appendix covers the following types of cables and connectors:

- Console Cable
- AUX Cable
- Electrical Port Connector
- Optical Fiber Cable Connectors

### Console Cable

Figure 44 illustrates the console cable and connectors.

**Figure 44** The Console cable

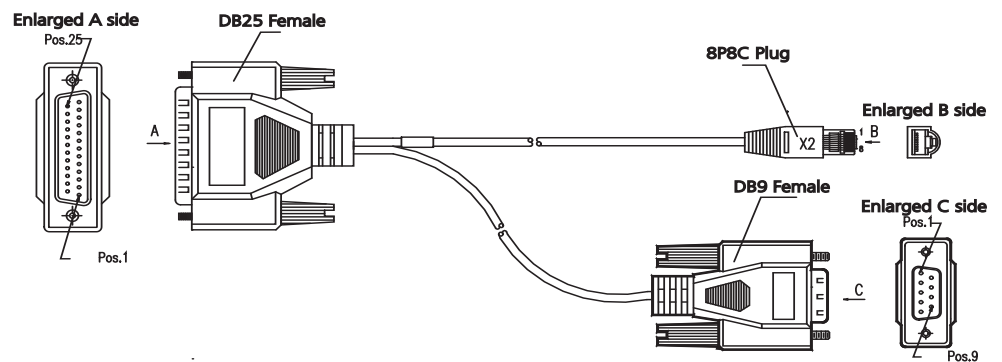

Table 53 lists console cable pin-outs.

**Table 53** Console Cable Pin-outs

RJ-45	Signal	Direction	DB-25	DB-9
1	RTS	<---	4	7
2	DTR	<---	20	4
3	TXD	<---	2	3
4	CD	--->	8	1
5	GND	---	7	5
6	RXD	--->	3	2
7	DSR	--->	6	6
8	CTS	--->	5	8

### AUX Cable

Figure 45 illustrates the AUX cable.

**Figure 45** The AUX Cable

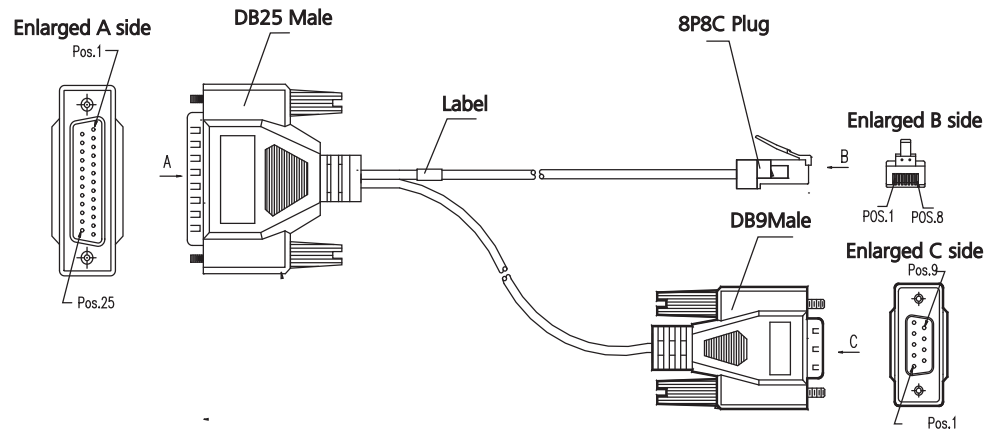

Table 54 lists the AUX cable pin-outs.

**Table 54** AUX Cable Pin-outs

RJ-45	Signal	Direction	DB-25	DB-9
1	RTS	--->	4	7
2	DTR	--->	20	4
3	TXD	--->	2	3
4	CD	<---	8	1
5	GND	---	7	5
6	RXD	<---	3	2
7	DSR	<---	6	6
8	CTS	<---	5	8

## Electrical Port Connector

Figure 46 illustrates the RJ-45 connector.

**Figure 46** The RJ-45 Connector

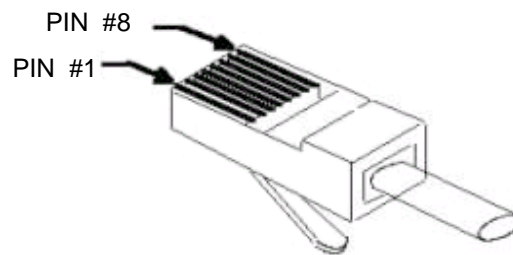

Table 55 lists RJ-45 MDI port pin-outs.

**Table 55** RJ-45 MDI Port Pin-outs

Pinout	10BASE-T/100BASE-TX		1000BASE-T	
	Signal	Function	Signal	Function
1	Tx+	Send data	BIDA+	Send data to direction A
2	Tx-	Send data	BIDA-	Receive data from direction A

**Table 55** RJ-45 MDI Port Pin-outs (continued)

Pinout	10BASE-T/100BASE-TX		1000BASE-T	
3	Rx+	Receive data	BIDB+	Send data to direction B
4	Reserved	-	BIDC+	Receive data from direction C
5	Reserved	-	BIDC-	Send data to direction C
6	Rx-	Receive data	BIDB-	Receive data from direction B
7	Reserved	-	BIDD+	Send data to direction D
8	Reserved	-	BIDD-	Receive data from direction D



*Tx = Send data Rx = Receive data BI = I-directional data.*

Table 56 lists RJ-45 MDI-X Port Pin-outs.

**Table 56** RJ-45 MDI-X Port Pinouts

Pinout	10BASE-T/100 BASE-TX		1000BASE-T	
	Signal	Function	Signal	Function
1	Rx+	Receive data	BIDB+	Send data to direction B
2	Rx-	Receive data	BIDB-	Receive data from direction B
3	Tx+	Send data	BIDA+	Send data to direction A
4	Reserved	-	BIDD+	Receive data from direction D
5	Reserved	-	BIDD-	Send data to direction D
6	Tx-	Send data	BIDA-	Receive data from direction A
7	Reserved	-	BIDC+	Send data to direction C
8	Reserved	-	BIDC-	Receive data from direction C

## Optical Fiber Cable Connectors

Figure 47 illustrates the SC optical fiber cable connector.

**Figure 47** SC Optical Fiber Connector

Figure 48. illustrates the MT-RJ fiber optic cable connector.

**Figure 48** The MT-RJ Fiber Connector

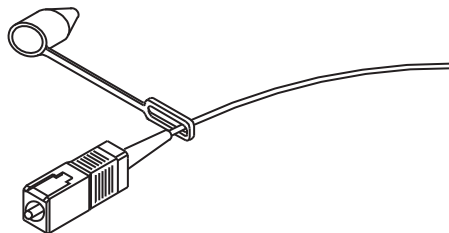
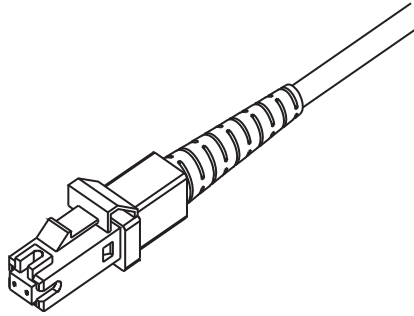

Figure 49 illustrates the LC connector.

**Figure 49** LC Connector

