

Digital Video Disc Recorder
Owner's Manual

DVDR1000



Important!
Return your
Warranty
Registration Card
within 10 days.
See why inside.



Read this manual first!

Congratulations on purchasing this Philips product. We've included everything you need to get started. If you have any problems, Philips Representatives can help you get the most from your new product by explaining:

- Hookups,
- First Time Setup, and
- Feature Operation.

Do not attempt to return this product to the store.

For fast help, call us first!
1-800-531-0039

Thank you for making Philips a part of your home!

Let's make things better.



PHILIPS

Return your Warranty Registration card today to ensure you receive all the benefits you're entitled to.

Once your PHILIPS purchase is registered, you're eligible to receive all the privileges of owning a PHILIPS product. So complete and return the Warranty Registration Card enclosed with your purchase at once. And take advantage of these important benefits.

Warranty Verification

Registering your product within 10 days confirms your right to maximum protection under the terms and conditions of your PHILIPS warranty.

Owner Confirmation

Your completed Warranty Registration Card serves as verification of ownership in the event of product theft or loss.

Model Registration

Returning your Warranty Registration Card right away guarantees you'll receive all the information and special offers which you qualify for as the owner of your model.

PHILIPS

Congratulations on your purchase, and welcome to the "family!"

Dear PHILIPS product owner:

Thank you for your confidence in PHILIPS. You've selected one of the best-built, best-backed products available today. We'll do everything in our power to keep you happy with your purchase for many years to come.

As a member of the PHILIPS "family," you're entitled to protection by one of the most comprehensive warranties and outstanding service networks in the industry. What's more, your purchase guarantees you'll receive all the information and special offers for which you qualify, plus easy access to accessories from our convenient home shopping network.

Most importantly, you can count on our uncompromising commitment to your total satisfaction. All of this is our way of saying welcome - and thanks for investing in a PHILIPS product.

Sincerely,



Lawrence J. Blanford
President and Chief Executive Officer

P.S. Remember, to get the most from your PHILIPS product, you must return your Warranty Registration Card within 10 days. So please mail it to us right now!



Know these safety symbols



 This "bolt of lightning" indicates uninsulated material within your unit may cause an electrical shock. For the safety of everyone in your household, please do not remove product covering.

 The "exclamation point" calls attention to features for which you should read the enclosed literature closely to prevent operating and maintenance problems.

WARNING: TO PREVENT FIRE OR SHOCK HAZARD, DO NOT EXPOSE THIS EQUIPMENT TO RAIN OR MOISTURE.

CAUTION: To prevent electric shock, match wide blade of plug to wide slot, fully insert.

ATTENTION: Pour éviter les chocs électriques, introduire la lame la plus large de la fiche dans la borne correspondante de la prise et pousser jusqu'au fond.

For Customer Use

Enter below the Serial No. which is located on the rear of the cabinet. Retain this information for future reference.

Model No. _____
Serial No. _____



PHILIPS

Visit our World Wide Web Site at <http://www.philips.com>

General Information

Contents	3
Safety Information	4-5
Introduction	6

Getting Started

Playable Discs	7
General Information	8
Hookups	9-15
Initial Setup	16-17

Basic Disc Playback and Features

Quick Disc Playback	18
Quick Recording	19

DVD Recorder Controls

Remote Control Buttons	20-21
Front Panel	22
Display	23
Rear Panel	24
Menu Bars	25
On-screen Symbols, Status Box	26
Information Boxes	27

Advanced Disc Playback and Features

Title/Disc Menus, Chapter/Track Selection	28
Audio Language, Subtitles	29
Zoom, Camera Angle	30
Sound, Still Picture/Frame-by-Frame Playback	31
Slow Motion, Forward and Reverse Searching	32
Time Search, Scan	33
Repeat, Repeat A-B	34
Index Picture Screen	35

Advanced Installation

Installation: Automatic Channel Programming	36
Installation: VCR Plus+ Ch.	37
Installation: Clock Setting	38-39

Recording Options

One-Touch Recording	40
Timer Recording	41
VCR Plus+ Timer Recording	42
Erasing Timer Recordings, Error Messages	43
Title Settings Menu	44
Manual Recording Volume, Append Recording	45
Record Settings, Chapter Markers	46

Editing

Editing: Disc Information Screen	47
Editing	48

Additional Features and Setup Options

Access Control	49-53
User Preference Settings	54
Picture Settings	55
Digital Output	56
Analog Output	57
Language Settings, Recording Audio	58
Night Mode, Remote Control Settings	59
Using Your Recorder's Remote Control with Your TV	60-61

Information You May Need

Helpful Hints	62-63
Glossary	64
Diagnostic Test	65
Specifications	66
Limited Warranty	67
Information Index	68

4 Safety Information

Safety Precautions

Warning: To prevent fire or shock hazard, do not expose this equipment to rain or moisture.

Federal Communications Commission (FCC) Warning: Any unauthorized changes or modifications to this equipment void the user's authority to operate it.

Laser Safety

This unit employs a laser. Only a qualified service person should remove the cover or attempt to service this device, due to possible eye injury.

CAUTION: Use of controls or adjustments or performance of procedures other than those specified herein may result in hazardous radiation exposure. The set complies with the FCC-Rules, Part 15 and with 21 CFR 1040.10.

CAUTION: Visible and invisible laser radiation when open and interlock defeated. Do not stare into the beam. The beam is located inside, near the deck mechanism.

Special Information for Canadian Users

This digital apparatus does not exceed the Class B limits for radio noise emissions from digital apparatus as set out in the Radio Interference Regulations of the Canadian Department of Communications. CET APPAREIL NUMÉRIQUE N'ÉMET PAS DE BRUITS RADIOÉLECTRIQUES DÉPASSANT LES LIMITES APPLICABLES DANS LA RÉGLEMENT SUR LE BROUILLAGE RADIOÉLECTRIQUES ÉDICTÉ PAR LE MINISTÈRE DES COMMUNICATIONS DU CANADA.

Radio/TV Interference

This equipment has been tested and found to comply with the limits for a Class B digital device, pursuant to Part 15 of the FCC Rules. These limits are designed to provide reasonable protection against harmful interference in a residential installation. This equipment generates, uses, and can radiate radio frequency energy and, if not installed and used in accordance with the instructions, may cause harmful interference to radio communications. However, there is no guarantee that interference will not occur in a particular installation. If this equipment does cause harmful interference to radio or television reception, which can be determined by turning the equipment off and on, try to correct the interference by one or more of the following measures:

- 1) Reorient or relocate the receiving antenna.
- 2) Increase the separation between the equipment and the receiver.
- 3) Connect the equipment into an outlet on a circuit different from that to which the receiver is connected.
- 4) Consult the dealer or an experienced radio/TV technician for help.

WARNING:

This device complies with Part 15 of the FCC rules. Operation is subject to the following two conditions:

- 1) This device may not cause harmful interference.
- 2) This device must accept any interference received, including interference that may cause undesired operation.

IMPORTANT:

This product was FCC verified under test conditions that included use of shielded cables and connectors between system components. Use shielded cables to reduce the possibility of causing interference to radios, televisions, and other electronic devices. If you have any problems, contact your supplier.

Copyright Protection

Unauthorized copying, broadcasting, public performance, and lending of Discs are prohibited. This product incorporates copyright protection technology that is protected by method claims of certain U.S. patents and other intellectual property rights owned by Macrovision Corporation and other rights owners. Use of this copyright protection technology must be authorized by Macrovision Corporation and is intended for home and other limited viewing uses only unless otherwise authorized by Macrovision Corporation. Reverse engineering or disassembly is prohibited.

Declaration of Conformity

Model Number: DVDR1000
Trade Name: Philips
Responsible Party: Philips Consumer Electronics
P.O. Box 14810, Knoxville, TN 37914-1810
(865) 521-4316

IMPORTANT SAFETY INSTRUCTIONS.

READ BEFORE OPERATING EQUIPMENT.

1. Read these instructions.
2. Keep these instructions.
3. Heed all warnings.
4. Follow all instructions.
5. Do not use this apparatus near water.
6. Clean only with a dry cloth.
7. Do not block any of the ventilation openings. Install in accordance with the manufacturer's instructions.
8. Do not install near any heat sources such as radiators, heat registers, stoves, or other apparatus (including amplifiers) that produce heat.
9. Do not defeat the safety purpose of the polarized or grounding-type plug. A polarized plug has two blades with one wider than the other. A grounding type plug has two blades and a third grounding prong. The wide blade or third prong are provided for your safety. When the provided plug does not fit into your outlet, consult an electrician for replacement of the obsolete outlet.
10. Protect the power cord from being walked on or pinched, particularly at plugs, convenience receptacles, and the point where they exit from the apparatus.
11. Only use attachments/accessories specified by the manufacturer.
12. Use only with a cart, stand, tripod, bracket, or table specified by the manufacturer or sold with the apparatus. When a cart is used, use caution  when moving the cart/apparatus combination to avoid injury from tip-over.
13. Unplug this apparatus during lightning storms or when unused for long periods of time.
14. Refer all servicing to qualified service personnel. Servicing is required when the apparatus has been damaged in any way, such as if the power-supply cord or plug is damaged, liquid has been spilled or objects have fallen into the apparatus, or if the apparatus has been exposed to rain or moisture, does not operate normally, or has been dropped.
15. This product may contain lead and mercury. Disposal of these materials may be regulated due to environmental considerations. For disposal or recycling information, please contact your local authorities or the Electronic Industries Alliance: www.eiae.org
16. **Damage Requiring Service** - The appliance should be serviced by qualified service personnel when:
 - A. The power supply cord or the plug has been damaged; or
 - B. Objects have fallen, or liquid has been spilled into the appliance; or
 - C. The appliance has been exposed to rain; or
 - D. The appliance does not appear to operate normally or exhibits a marked change in performance; or
 - E. The appliance has been dropped, or the enclosure damaged.

17. **Tilt/Stability** - All televisions must comply with recommended international global safety standards for tilt and stability properties of cabinet design.
 - Do not compromise these design standards by applying excessive pull force to the front, or top, of the cabinet, which could ultimately overturn the product.
 - Also, do not endanger yourself, or children, by placing electronic equipment/toys on the top of the cabinet. Such items could unsuspectingly fall from the top of the set and cause product damage and/or personal injury.
18. **Wall or Ceiling Mounting** - The appliance should be mounted to a wall or ceiling only as recommended by the manufacturer.
19. **Power Lines** - An outdoor antenna should be located away from power lines.
20. **Outdoor Antenna Grounding** - If an outside antenna is connected to the receiver, be sure the antenna system is grounded so as to provide some protection against voltage surges and built up static charges. Section 810 of the National Electrical Code, ANSI/NFPA No. 70-1984, provides information with respect to proper grounding of the mast and supporting structure grounding of the lead-in wire to an antenna discharge unit, size of grounding connectors, location of antenna discharge unit, connection to grounding electrodes and requirements for the grounding electrode. See Figure below.
21. **Object and Liquid Entry** - Care should be taken so that objects do not fall and liquids are not spilled into the enclosure through openings.
22. **Battery usage CAUTION** - To prevent battery leakage that may result in bodily injury or damage to the unit:
 - Install all batteries correctly, with + and - aligned as marked on the unit.
 - Do not mix batteries (old and new or carbon and alkaline, etc.).
 - Remove batteries when the unit is not used for a long time.

Example of Antenna Grounding per National Electrical Code

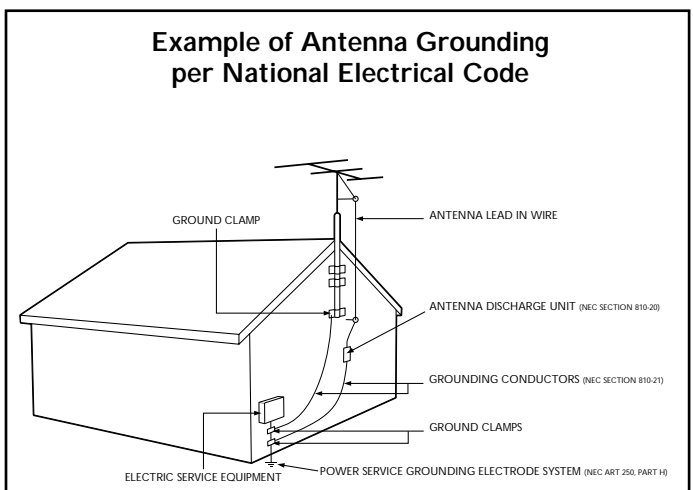

6 Introduction

Welcome!

Your Philips DVD Recorder both records DVD+RWs and plays prerecorded DVDs. You can record TV programs, edit camcorder recordings, and quickly access your DVD+RW recordings in the Index Picture Screen. Plus, the DVD+RW recordings you make on the Recorder will play on some DVD Players and DVD-ROM drives. You'll soon appreciate the digital picture and sound quality of DVD and DVD+RW, which will exceed the quality you have had with video cassette tapes.

Read this manual carefully to understand the latest features, then enjoy your new DVD Recorder.

Features

- Digital Theater System
- Dolby Digital Surround Sound
- DVD-Video Compatibility
- Fast Forward/Reverse Search
- i.LINK Digital Video connection
- Index Picture Screen
- NTSC/PAL compatibility
- Paused/Fast/Slow/Step-by-Step/Zoomed Playback
- Progressive Scan compatibility
- Repeat and Repeat A-B playback
- Screen Saver
- Time Search
- TruSurround by SRS
- VCR Plus+ Programming

Package Contents

- DVD Recorder
- Remote control with two AA batteries
- AC power cord
- One blank Philips DVD+RW
- One RF coaxial cable (black with silver tip, with single prong in center of tip)
- One S-Video cable (black with silver tip)
- One three-strand Component Video Cable (ends have blue, green, and red stripes)
- Two two-strand audio cables (ends have red and white stripes)
- One composite video cable (end has a yellow stripe)
- This owner's manual and registration materials

Environmental Information

Your system has materials that can be recycled and reused if disassembled by a specialized company. Please observe the local regulations regarding the disposal of packaging materials, exhausted batteries, and old equipment.

Safety Information

- Do not expose the system to excessive moisture, rain, sand, or heat sources.
- Place the DVD Recorder on a firm, flat surface.
- Keep the DVD Recorder away from domestic heating equipment and direct sunlight.
- When placing the DVD Recorder in a cabinet, allow about one inch of space all around the DVD Recorder for ventilation.

Cleaning Discs

- When a Disc becomes dirty, clean it with a cleaning cloth. Wipe the Disc from the center out, in a straight line.

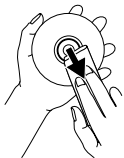

- Do not use solvents such as benzine, thinner, commercially available cleaners, or anti-static spray intended for analog discs.
- If the DVD Recorder cannot read Discs correctly, use a commonly available cleaning CD/DVD to clean the lens. Other cleaning methods may destroy the lens. Always keep the tray closed to avoid dust on the lens.
- The lens may cloud over if you suddenly move the DVD Recorder from cold to warm surroundings. Playing a Disc is not possible then. Leave the power on for about one hour with no Disc in the Recorder until normal playback is possible.

Manufactured under license from Dolby Laboratories. "Dolby," "Pro Logic," and the double-D symbol are trademarks of Dolby Laboratories. "DTS" and "DTS DIGITAL SURROUND" are registered trademarks of Digital Theater Systems, Inc. TRUSURROUND, SRS, and  are trademarks of SRS Labs, Inc. TRUSURROUND technology is manufactured under license from SRS Labs, Inc.

VCR Plus+ and PlusCode are registered trademarks of the Gemstar Development Corporation. The VCR Plus+ system is manufactured under license from Gemstar Development Corporation.

Copyright 2001 Philips Consumer Electronics.

This DVD Recorder will play various types of Discs. Some Disc types will only play on the Recorder; others will record in the Recorder; some will record and play. There are also a few types of Discs that will neither play nor record on this Recorder. To determine which Discs you should use with this Recorder, refer to the following information. Look for these logos on your Discs to determine whether the Disc will or will not play or record on the Philips DVD Recorder.

Discs for Recording and Playing



DVD+RW
(Digital Video Disc + Rewritable)

Discs Unsuitable for Recording or Playing



DVD-RAM



DVD-Audio

Discs for Playing Only



DVD
(Digital Video Disc)



Audio CD
(Compact Disc Digital Audio)



DVD-R
(DVD-Recordable)



Super Audio CD
(plays only the CD layer)



DVD-RW
(DVD-Rewritable)
(plays only when recorded in video mode and if finalized)



Video CD



Super Video CD



CD-R (CD-Recordable)
(plays only Audio CD contents)



CD-RW (CD-Rewritable)
(plays only Audio CD contents)

Region Codes and Color Systems

DVDs must meet the requirements for Region Codes and Color Systems before you can use them with the DVD Recorder. DVDs must be labelled for ALL regions or for Region 1 in order to play on this DVD Recorder. You cannot play Discs that are labeled for other regions. These symbols must appear on your DVDs, or you cannot play the DVD in this DVD Recorder.



The number inside the globe refers to a region of the world. Region 1 represents the United States, Canada, upper regions of North America, Bermuda, the U.S. Virgin Islands, and small regions near Australia.

Furthermore, recordings are made according to different color systems throughout the world. The most common color systems are NTSC, which is used primarily in the United States and North America, PAL, and SECAM.

This DVD Recorder is compatible with NTSC and PAL. Make sure the Discs you play were recorded in NTSC or PAL. The color system of the DVD may appear on the DVD or on the Disc case.

8 General Information

Battery Installation

- 1** Remove the battery compartment lid on the rear of the remote control by sliding the lid down, then off.
- 2** Place two AA batteries inside the battery compartment with their + and - ends aligned as indicated. Do not mix old and new batteries or different types of batteries (standard, alkaline, etc.).
- 3** Replace the battery compartment lid.

Using the Remote Control

Unless stated otherwise, the remote control can operate all the features of the DVD Recorder. Always point the remote control directly at the remote sensor on the front of the DVD Recorder, not the TV. *Details are on page 22.* Make sure there are no barriers between the remote control and the DVD Recorder.

The remote control also will operate some features of some TVs. *Details are on pages 60-61.*

When referring to this manual, remember...

- DVD** The feature is available on some Digital Video Discs.
- AUDIO CD** The feature is available on some Audio Compact Discs.
- VIDEO CD** The feature is available on some Video Compact Discs.
- DVD+RW** The feature is available on DVD+ReWritable Discs.

DVD Disc Menus...

Some explanations in this manual describe the DVD Disc Menus, which vary among DVDs. Movie producers set these menus, and not all DVDs have menus. But, if the DVD has a menu, access the Disc Menu by pressing the DISC MENU button on the remote control. *Details are on page 28.*

DVD Recorder Menus...

Some instructions explain how to use the DVD Recorder's menu (or the System Menu or Menu Bars) to set up features of the DVD Recorder or the Disc. You get to the DVD Recorder Menu by pressing SYSTEM MENU on the remote control. *Details are on page 25.* Even if a feature is set up in the DVD Recorder's menu, it will not be available if the current Disc does not include that feature.

Available Disc Features...

Features in this manual may not be available on every Disc. If the feature is not available, you cannot use the DVD Recorder to make the feature available. An "X" will appear in the top left corner of the TV screen if you try to access a feature that is not available on the current Disc.

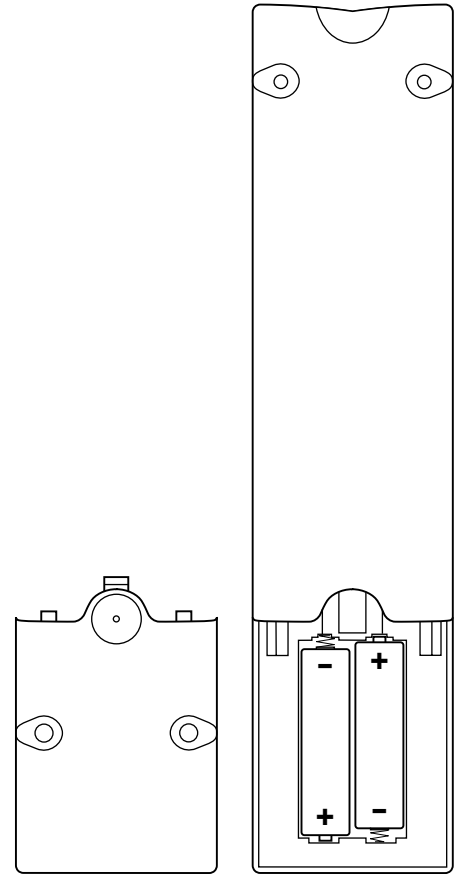

Determining the best possible connection...

The capabilities of your existing equipment, especially your TV, will determine your connection possibilities. However, the following guidelines describe which options provide the best picture and sound quality.

- ★★★★ Component Video provides the best picture quality. Progressive Scan Component Video has the highest quality, but use it only if the TV has Progressive Scan. *Details are on page 10.*
- ★★★ S-Video provides excellent picture quality. *Details are on page 11.*
- ★★ Composite Video (a yellow Video jack) provides good picture quality. *Details are on page 12.*
- ★★ Your TV may have only an RF-style jack, usually labeled Antenna In or 75 ohm. Connect the supplied RF coaxial cable to the TV jack on the DVD Recorder and to the Antenna In jack on your TV. Connect your antenna or Cable TV signal to the ANTENNA jack on the DVD Recorder as shown on page 10.
You will need an RF modulator in order to view the DVD Recorder at your TV. Set the RF modulator to channel 3 or 4, then set the TV to the same channel. Ask your dealer for details on RF modulator availability and compatibility.

- ★★★★ Digital audio connections provide the clearest sound. Connect one of the DVD Recorder's DIGITAL AUDIO OUT jacks (COAX (coaxial) or OPTICAL) to your Stereo for the best sound quality. *Details are on page 14.*
- ★★★ If digital connections are not possible, connect the DVD Recorder's red and white AUDIO OUT jacks to the Audio In jacks of your Stereo or TV. *Details are on pages 10-13.*

Before you begin...

- Refer to the manuals of your TV, Stereo, or other equipment as necessary. Note the style of jacks and connectors on the other equipment. Determine how to choose different Audio and Video In channels on your other equipment so you can see and hear the DVD Recorder on the TV, Stereo, etc.
- Disconnect all equipment from the power outlets. Connect the equipment to the power outlets only after you have finished hooking up everything. Never make or change connections with equipment connected to the power outlet.

Remember...

- Connect the DVD Recorder directly to the TV. For example, do not connect the DVD Recorder to a VCR, then connect the VCR to a TV. This type of connection may distort the picture and sound. Also, your VCR might have the copy protection system, which could distort the DVD image.
- Set the TV to the correct Video In channel. Such channels may be called AUX or AUXILIARY IN, AUDIO/VIDEO or A/V IN, EXT1 or EXT2, etc. These channels often are near channel 00. See your TV manual for details. Or, change TV channels until you see the blue Philips DVD screen saver on the TV screen.
- Set the Stereo to the correct channel or "source" mode.
- Do not connect the DVD Recorder's AUDIO OUT jacks to the PHONO IN jack of your Stereo.
- You only need one audio connection and one video connection between the DVD Recorder and your TV. So, you might not use all the jacks on the Recorder.

Once you determine the best option, find your choice on pages 10-15. Follow the steps for the hookup you chose.

When you finish your connections and turn on the DVD Recorder for the first time, you must complete the Initial Setup. Initial Setup helps you set up TV channels, menu languages, and other features. Go to page 16 to continue.

10 Hookups (cont'd)

Connecting to a TV Only TV has Component Video In Jacks

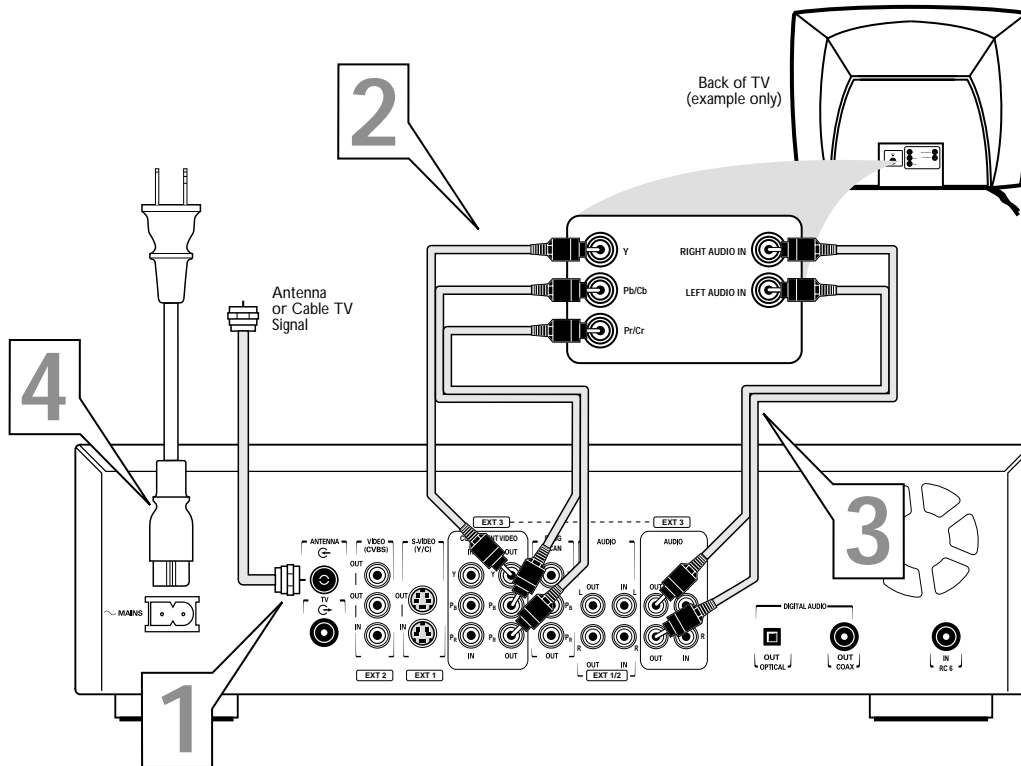

- 1 Connect your Antenna or Cable TV signal to the ANTENNA jack on the rear of the DVD Recorder.
- 2 Connect the DVD Recorder's COMPONENT VIDEO OUT Y Pb Pr jacks (EXT 3) to the corresponding COMPONENT VIDEO IN jacks on the TV. Use the supplied three-strand component video cable, which has ends with red, blue, and green stripes. Match the cable stripe colors to the jack colors.
- 3 Connect the DVD Recorder's red and white AUDIO OUT (Left and Right) (EXT 3) jacks to the left/right AUDIO IN jacks on the TV. Use one of the supplied two-strand audio cables, which has ends with red and white stripes. Match the cable stripe colors to the jack colors.
- 4 Connect the supplied power cord to the MAINS (AC Power) jack on the rear of the DVD Recorder. Connect the power cords of the DVD Recorder and the TV to a power outlet.
- 5 Press the STAND BY/ON button on the front of the DVD Recorder to turn on the DVD Recorder. The STAND BY/ON light will turn green.
- 6 Turn on the TV power. Set the TV to the correct Component Video In channel. See your TV owner's manual for details. Or, change channels at the TV until you see the DVD screen saver or Initial Setup screen on the TV screen. The Initial Setup screen will appear the first time you turn on the Recorder. Go to page 16 to continue.

Helpful Hints

- If your TV has Progressive Scan, connect the DVD Recorder's PROG SCAN OUT Y Pb Pr jacks to the TV's Progressive Scan In jacks instead. Progressive Scan produces a clearer picture by doubling the number of visible picture lines per field. This provides a jitter-free, sharp, quiet picture. Only use these connections if your TV has Progressive Scan. Check your TV manual for more information.
- On the TV, the component video in jacks may be labeled YUV or Pr/Cr Pb/Cb Y and may be green, blue, and red.

Connecting to a TV Only TV has an S-Video In Jack

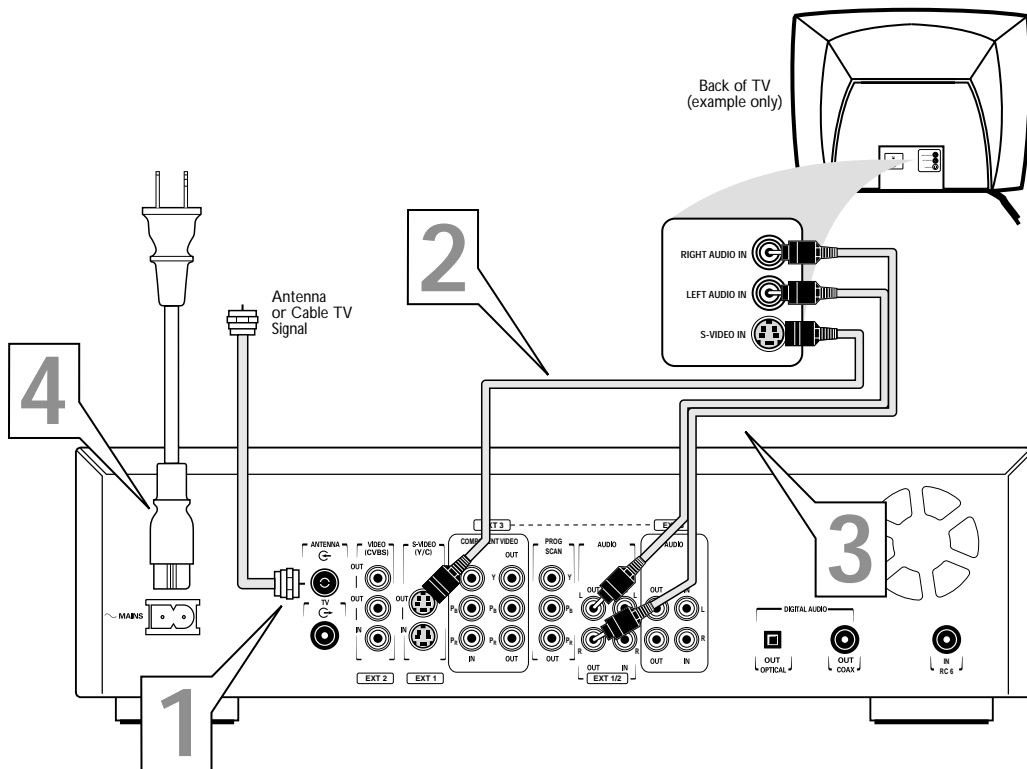

- 1** Connect your Antenna or Cable TV signal to the **ANTENNA** jack on the rear of the DVD Recorder.
- 2** Connect the supplied S-Video cable to the **S-VIDEO OUT (Y/C) (EXT 1)** jack of the DVD Recorder and to the TV's **S-VIDEO In** jack.
- 3** Connect a supplied two-strand audio cable to the red and white **AUDIO OUT (EXT 1/2)** left and right jacks on the DVD Recorder and to the left/right **AUDIO IN** jacks on the TV. The supplied two-strand audio cable has red and white stripes on the cable ends. Match the cable stripe colors to the jack colors.
- 4** Connect the supplied power cord to the **MAINS (AC Power)** jack on the rear of the DVD Recorder. Connect the power cords of the DVD Recorder and the TV to a power outlet.
- 5** Press the **STAND BY/ON** button on the front of the DVD Recorder to turn on the DVD Recorder. The **STAND BY/ON** light will turn green.
- 6** Turn on the TV power. Set the TV to the **S-Video In** channel. See your TV owner's manual for details. Or, change channels at the TV until you see the DVD screen saver or Initial Setup screen on the TV screen. *The Initial Setup screen will appear the first time you turn on the Recorder. Go to page 16 to continue.*

Helpful Hint

- On the TV, the S-Video In jack may be labeled Y/C, S-Video, or S-VHS (super video).

12 Hookups (cont'd)

Connecting to a TV Only TV has a yellow CVBS Video In jack

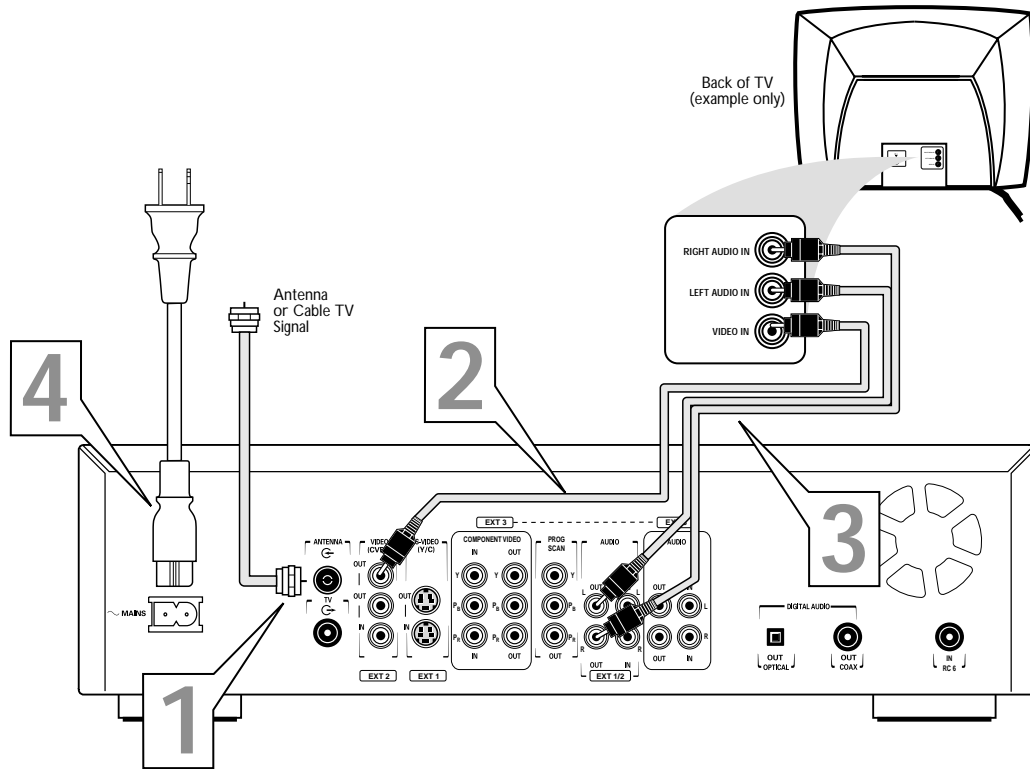

1 Connect your Antenna or Cable TV signal to the ANTENNA jack on the rear of the DVD Recorder.

2 Connect the yellow VIDEO OUT (CVBS) (EXT 2) jack of the DVD Recorder to the corresponding VIDEO IN jack on your TV. Use the supplied video cable, which has a yellow stripe on the cable end.

3 Connect a supplied two-strand audio cable to the red and white AUDIO OUT (EXT 1/2) left and right jacks on the DVD Recorder and to the left/right AUDIO IN jacks on the TV. The supplied two-strand audio cable has red and white stripes on the cable ends. Match the cable stripe colors to the jack colors.

4 Connect the supplied power cord to the MAINS (AC Power) jack on the rear of the DVD Recorder. Connect the power cords of the DVD Recorder and the TV to a power outlet.

5 Press the STAND BY/ON button on the front of the DVD Recorder to turn on the DVD Recorder. The STAND BY/ON light will turn green.

6 Turn on the TV power. Set the TV to the correct Audio/Video In channel. Such channels may be called AUX or AUXILIARY IN, AUDIO/VIDEO or A/V IN, EXT1 or EXT2, etc. These channels often are near channel 00. See your TV owner's manual for details. Or, change channels at the TV until you see the DVD screen saver or Initial Setup menu on the TV screen. The Initial Setup screen will appear the first time you turn on the Recorder. Go to page 16 to continue.

Helpful Hint

- On the TV, the Video In jack is usually yellow and might be labeled video, CVBS, composite, or baseband.

Connecting to a TV and a two-channel Stereo (Stereo has Dolby Pro Logic or right/left Audio In jacks)

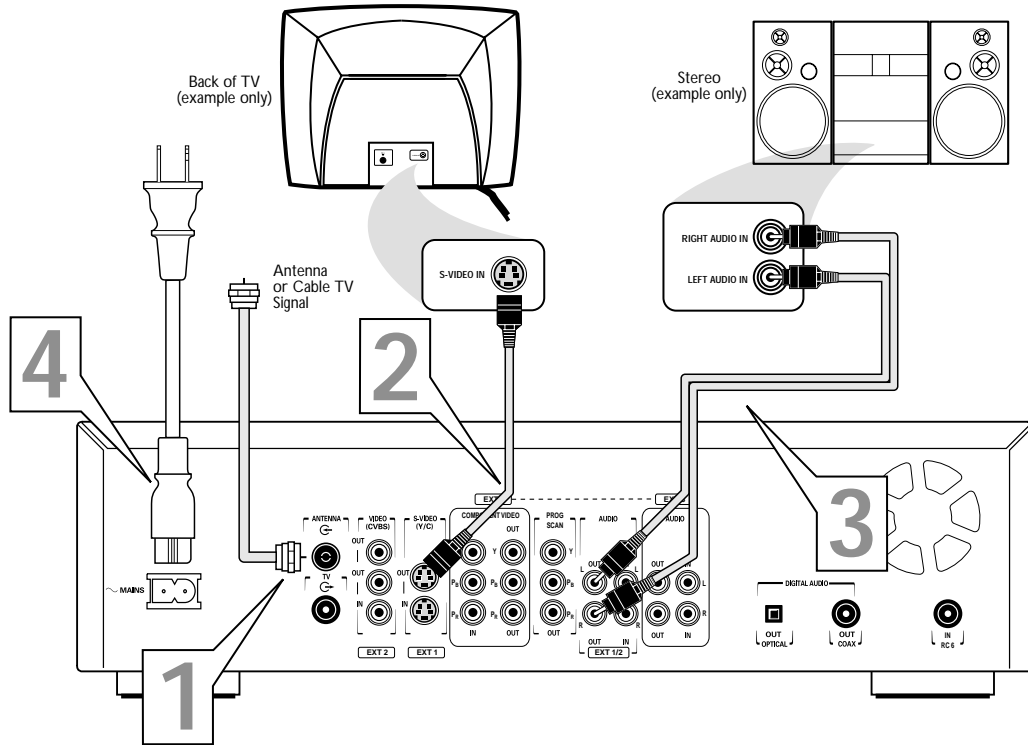

- 1** Connect your Antenna or Cable TV signal to the ANTENNA jack on the rear of the DVD Recorder.
- 2** Connect the supplied S-Video cable to the S-VIDEO OUT (Y/C) (EXT 1) jack of the DVD Recorder and to the TV's S-VIDEO IN jack.
- 3** Connect a supplied two-strand audio cable to the red and white AUDIO OUT (EXT 1/2) left and right jacks on the DVD Recorder and to the left/right AUDIO IN jacks on the Stereo. The supplied two-strand audio cable has red and white stripes on the cable ends. Match the cable stripe colors to the jack colors.
- 4** Connect the supplied power cord to the MAINS (AC Power) jack on the rear of the DVD Recorder. Connect the power cords of the DVD Recorder, Stereo, and TV to a power outlet.
- 5** Turn on the Stereo power and set your Stereo to the correct Audio In channel or sound source. Refer to the Stereo owner's manual.
- 6** Press the STAND BY/ON button on the front of the DVD Recorder to turn on the DVD Recorder. The STAND BY/ON light will turn green.
- 7** Turn on the TV power. Set the TV to the correct S-Video In channel. These channels often are near channel 00. See your TV owner's manual for details. Or, change channels at the TV until you see the DVD screen saver or Initial Setup menu on the TV screen. The Initial Setup screen will appear the first time you turn on the Recorder. Go to page 16 to continue.

Helpful Hints

- Set the Analog output accordingly. Details are on page 57.
- If you prefer or need to use the VIDEO OUT (CVBS) or COMPONENT VIDEO OUT Y Pb Pr jacks instead, see pages 10 and 12. You only need one video connection.

14 Hookups (cont'd)

Connecting to a TV and a Stereo Receiver (Receiver has Dolby Digital™, MPEG2, or Digital Theater System)

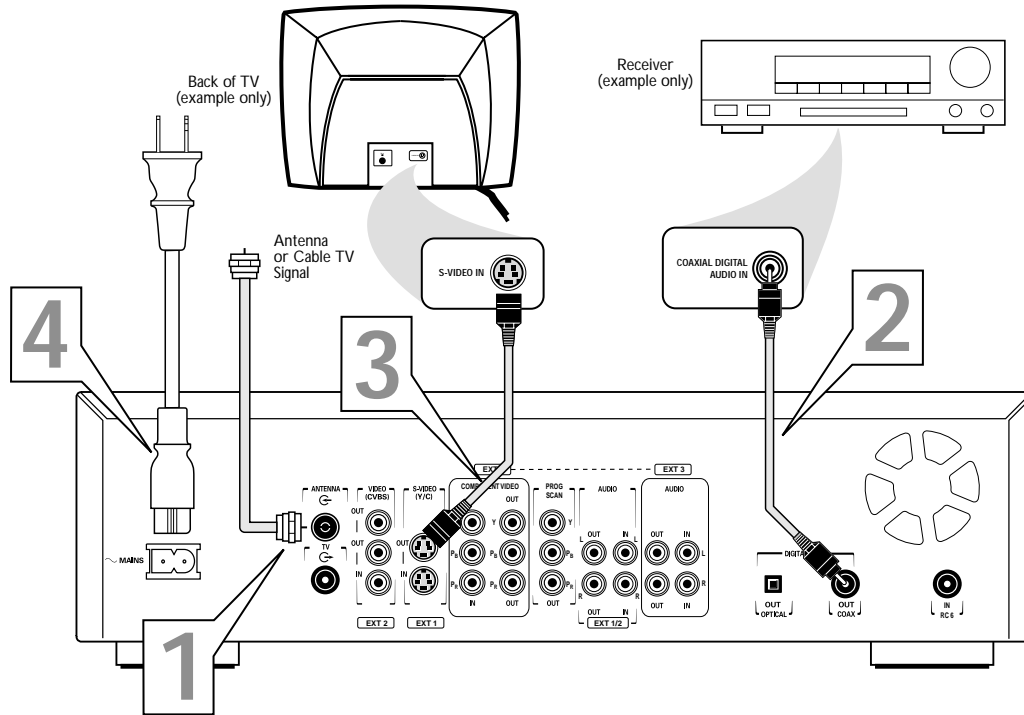

- 1** Connect your Antenna or Cable TV signal to the ANTENNA jack on the rear of the DVD Recorder.
- 2** Connect one of the DVD Recorder's DIGITAL AUDIO OUT jacks (COAX (coaxial) or OPTICAL) to the corresponding DIGITAL AUDIO IN jack on your Stereo. You only need one connection. Use an appropriate digital audio cable (not supplied).
- 3** Connect the supplied S-Video cable to the S-VIDEO OUT (Y/C) (EXT 1) jack of the DVD Recorder and to the TV's S-VIDEO IN jack.
- 4** Connect the supplied power cord to the MAINS (AC Power) jack on the rear of the DVD Recorder. Connect the power cords of the DVD Recorder, Stereo, and TV to a power outlet.
- 5** Turn on the Stereo power and set your Stereo to the correct Digital Audio In channel or sound source. Refer to the Stereo owner's manual.
- 6** Press the STAND BY/ON button on the front of the DVD Recorder to turn on the DVD Recorder. The STAND BY/ON light will turn green.
- 7** Turn on the TV power. Set the TV to the correct S-Video In channel. These channels often are near channel 00. See your TV owner's manual for details. Or, change channels at the TV until you see the DVD screen saver or Initial Setup menu on the TV screen. The Initial Setup screen will appear the first time you turn on the Recorder. Go to page 16 to continue.

Helpful Hints

- Set the Digital output accordingly. Details are on page 56.
- If your Digital Output setting does not match your Stereo's capabilities, the Stereo may produce a strong, distorted sound or no sound at all.
- Your Stereo must support MPEG2, Dolby Digital™ or Digital Theater System (DTS). Check the Stereo's manual.
- To use the VIDEO OUT (CVBS) or COMPONENT VIDEO OUT Y Pb Pr jacks instead, see pages 10 and 12.
- A small, square, black cap protects the OPTICAL jack when it is not in use. Remove the cap if you want to use the jack; replace the cap when the jack is not in use.

Connecting to Other Equipment (optional)

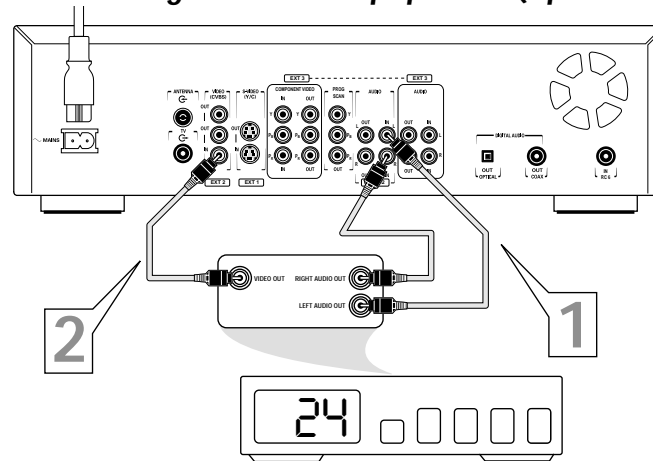

- After connecting the Recorder directly to your TV, additional IN jacks will be available on the rear of the Recorder. You may connect other equipment to these jacks, including a Cable Box, Video Cassette Recorder (VCR) or a DVD Player. The example above shows a Cable Box connection.
- To watch the material playing on the other equipment as usual, turn off the DVD Recorder.
- Most prerecorded video cassettes and DVDs are copy protected. If you try to copy them with the DVD Recorder, the Recorder display may show 'COPY PROTECT.'
- If you record material that is playing on a VCR onto a DVD+RW, adjust the tracking on the VCR first. If the Recorder's display shows "NO SIGNAL," adjust the tracking. See your VCR owner's manual for details on tracking adjustment.
- Do not connect a Progressive Scan video source to the COMPONENT VIDEO IN jacks (EXT3). The DVD Recorder cannot record material that is playing through a Progressive Scan source.

Connecting to a Camcorder (optional)

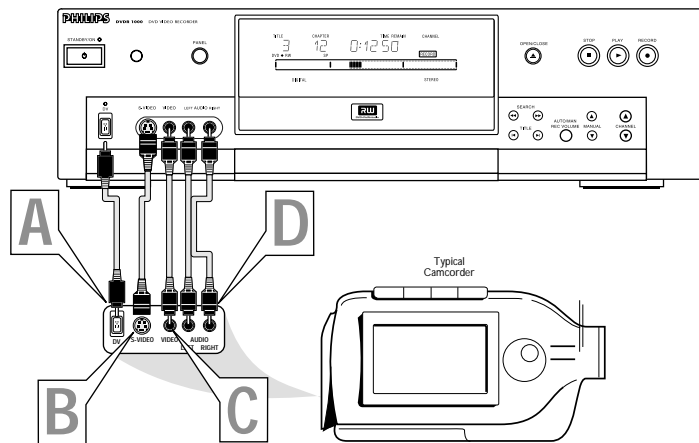

- A** If you have a DV or Digital 8 camcorder, connect the Recorder's I-LINK DV IN jack to the Camcorder's I-LINK OUT jack. Use an i-link cable (not supplied).
- B** If you have a Hi-8 or S-VHS camcorder, connect an S-Video cable to the Recorder's S-VIDEO IN jack and to the camcorder's S-Video Out jack. Connect Audio cables to the AUDIO IN (Left and Right) jacks on the front of the Recorder and to the AUDIO OUT jacks on the camcorder.
- C** If the camcorder only has a composite-style Video out jack (usually yellow), connect a video cable to the DVD Recorder's VIDEO IN jack and to the camcorder's Video Out jack. Connect Audio cables to the AUDIO IN (Left and Right) jacks on the front of the DVD Recorder and to the AUDIO OUT jacks on the Camcorder.

You need only one connection. You might not use all the jacks on the front of the Recorder. To see the camcorder picture on your TV, select the correct channel at the Recorder and the TV. At the Recorder, in Tuner mode, choose CAM1, CAM2, or CAM3. *Details are on page 22.* At the TV, choose the TV channel that corresponds to the jacks you used on the rear of the Recorder to connect the Recorder to the TV. The TV's Video In channel may be referred to as Video In, Aux or Auxiliary In, Audio/Video or A/V In, External or EXT IN, etc. If you have trouble finding the right channel, keep changing TV channels until you see the camcorder image playing on the TV screen.

16 Initial Setup

Initial Setup screens will appear the very first time you turn on the Recorder. These on-screen messages and menus will help you set up Recorder features quickly, including TV channels and language options. Follow the steps below to set up the Recorder as directed on the TV screen. **You can not turn off the Recorder until you finish the Initial Setup. The only way to quit the Initial Setup is to disconnect the power cord. If you quit, the Initial Setup screens will appear again the next time you turn on the Recorder. The screens will not go away until you finish the Initial Setup.**

If the setup screens do not appear, your Recorder has been set up previously. You can always change setup items later. For details on how to change these items later, see the pages listed at each step below for each feature.

- 1 Press ON/OFF to turn on the Recorder.**
- 2** The Menu Language screen will appear first automatically. Press **▼▲** to choose English, Espanol, or Francais, then press the **OK** button.
The DVD Recorder's menus will be in the language you selected.
To change the Recorder's Menu Language settings later, see page 58.

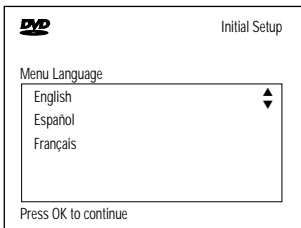

- 3** The Audio Language menu appears next. Press **▼▲** to choose the language you prefer, then press **OK**.
The Recorder will automatically play Discs in the language you selected if the language is available on the Disc. The DVD Disc menu will appear in the same language, if available on the Disc. Some Discs require you to choose the audio language from the Disc menu. The Disc preferences or defaults may override your selection in the Recorder's Audio Language menu.
To change the Audio Language settings later (as Playback Audio), see page 58.

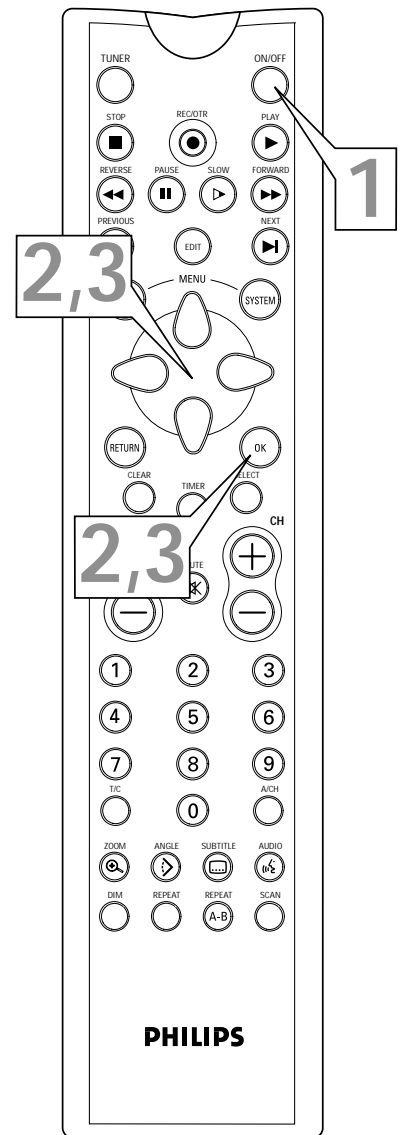
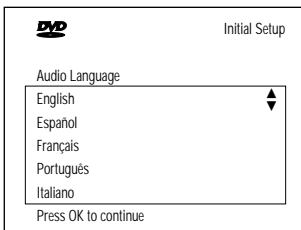

Continued on page 17

Continued from previous page

- 4** The Subtitle Language menu appears next. **Press ▼▲ to choose the language you prefer for subtitles, then press OK.** The Recorder will automatically show subtitles in the language you selected if subtitles are available in that language on the Disc. If your selected subtitle language is not available, either there will be no subtitles or subtitles will be in the default language of the Disc. Some DVDs require you to choose a subtitle language from the Disc menu. Disc preferences or defaults may override your selection in the Recorder's Subtitle Language menu.
To change the Subtitle Language settings later, see pages 29 and 58.

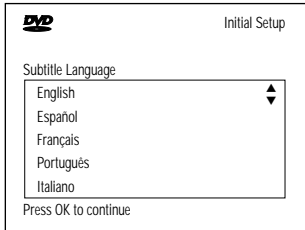

- 5** The TV Shape menu appears next. **Press ▼▲ to choose the preferred TV Shape, then press OK.**
To change the TV Shape later or for details on TV Shapes, see page 55.

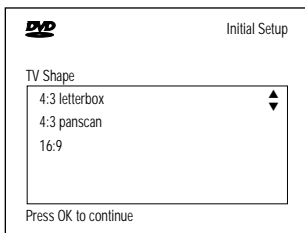

- 6** "If you have connected the antenna - press OK" appears next. **If you have connected an Antenna or Cable TV signal to the Recorder's ANTENNA jack, press OK.** If you have not connected the Antenna or Cable TV signal, take a moment now to do so. After the Antenna/Cable is connected, press OK. *Details are on pages 10-14.*
To reset TV channels later, or to add/delete new channel choices later, see page 36.

- 7** "Searching for TV channels" will appear, along with a scale showing channels are being memorized. The number of channels found will show on the screen as the searching progresses. This will take a few minutes, depending on the number of channels available in your area.
 When the channel search finishes, "Auto ch. search complete" will appear, along with the total number of channels found.

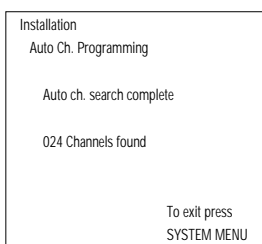

- 8** **Press SYSTEM MENU.** The Recorder is ready for use!

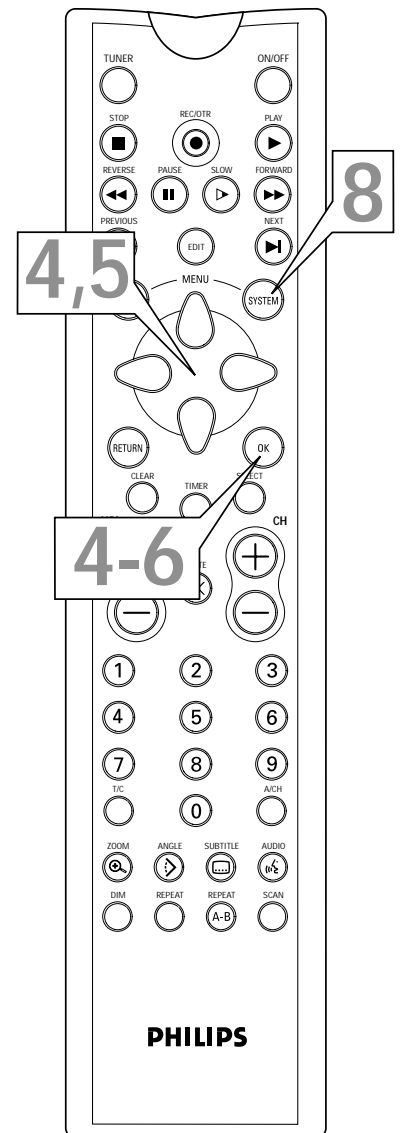

18 Quick Disc Playback

DVD AUDIO CD VIDEO CD DVD+RW

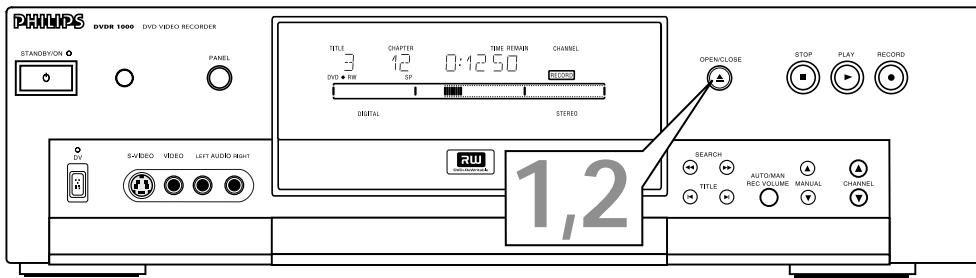

There are many playback features and options available on Discs. After familiarizing yourself with the DVD Recorder as described on pages 20-27, see pages 28 and following to try additional playback features.

1 Press **STAND BY / ON** to turn on the DVD Recorder. The **STAND BY / ON** light will be green when the power is On. **Turn on your TV. Set it to the correct Video In channel.** You should see the blue Philips DVD screen saver on the TV screen (if no Disc is in the Recorder). *Details are on pages 9-14.*

2 Press **OPEN/CLOSE** on the front of the DVD Recorder to open the disc tray. (You can not open the disc tray using the remote control.) **Load your Disc in the tray**, with the label facing up. If the Disc (DVD) is two-sided, make sure the side you want to play is facing up.

3 Press **OPEN/CLOSE** again to close the tray.

4 **Playback may start automatically. If not:**

- If you are playing a DVD, a Disc menu may appear. If the Title or Chapter selections are numbered, press a Number button to select an item. Or, press **▼▲◀▶** to select an item, then press **OK**. Playback will begin. Or, follow the on-screen instructions as detailed in the DVD Disc menu.
- If you are playing an Audio CD, press **PLAY ▶** to start playback.
- If you are playing a DVD+RW, the Index Picture Screen will appear. Press **▼▲** to select the Title you want to play, then press **OK**. If the Disc is a new blank Disc, the display will show "EMPTY DISC." *Details are on page 35.*

5 To stop playback at any time, press **STOP ■**.

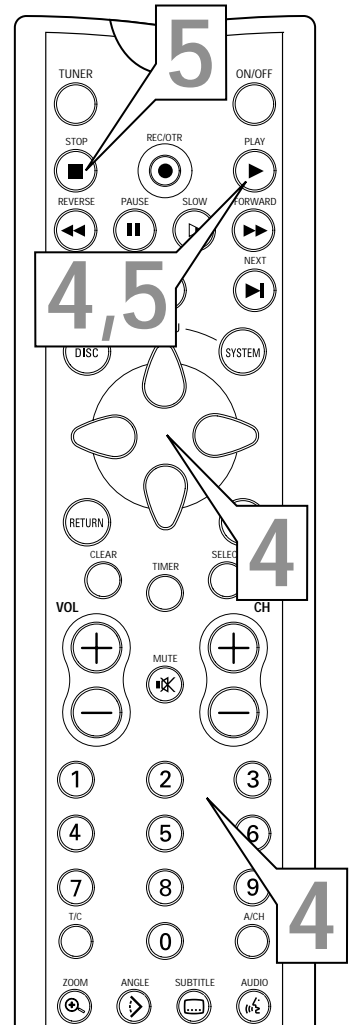

Helpful Hints

- If the Disc is Locked by Access Control, you must enter the four-digit code or authorize the Disc. *Details are on pages 49-53.*
- DVDs have a region code. Your Recorder will not play Discs that have a region code different from the region code of your Recorder. The Recorder's region code is 1 (one). *Details are on page seven.*
- You can not record only Audio (sound) to a DVD+RW. You must record both audio and video (sound and picture).

DVD+RW

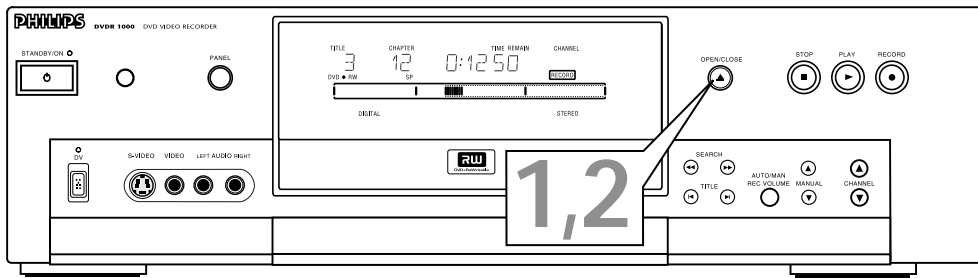

The DVD Recorder can record TV programming onto a DVD+RW. Before you begin, make sure you have installed the TV channels. *Details are on pages 16-17 and 36.* Using an unprotected, recordable DVD+RW, follow the steps below to record TV channels. For additional recording options, see pages 40-46.

- 1** Press **OPEN/CLOSE** ▲ on the front of the DVD Recorder to open the disc tray. Or, press and hold **STOP** ■ on the remote control to open or close the Disc tray.
- 2** Insert a recordable **DVD+RW**, with the label facing up. Press **OPEN/CLOSE** ▲ to close the disc tray. The Index Picture Screen will appear. *Details are on page 35.* If the Disc is empty and has no recordings, "EMPTY DISC" will appear on the Recorder's display.
- 3** Press ▼ to select an empty **Title box**, which indicates space available on the Disc for recording. To avoid overwriting previous recordings, choose the last empty Title box.
- 4** Press **TUNER** to see TV channels through the DVD Recorder.
- 5** Press **CH+/-** or the **Number** buttons to select the channel you wish to record.
To record material playing on equipment you connected to the Recorder, select **EXT1**, **EXT2**, **EXT3**, **CAM1**, **CAM2**, or **CAM3**. Choose the **EXT** (External) or **CAM** (Camera) channel that matches the jack to which you connected the other equipment. For example, if you connected a camcorder to the **S-VIDEO CAM1** jack on the front of the DVD Recorder, press **CH+/-** to choose **CAM1**. **CAM1** will appear in the Tuner Information Box. *Details are on page 27.*
- 6** Press **REC/OTR** to begin recording the selected channel. **RECORD** will appear in red on the Recorder's display panel.
- 7** Press **STOP** ■ to stop recording. **RECORD** will flash briefly on the display panel. The Index Picture Screen will reappear after a few seconds. To edit your recordings later, see pages 47-48.

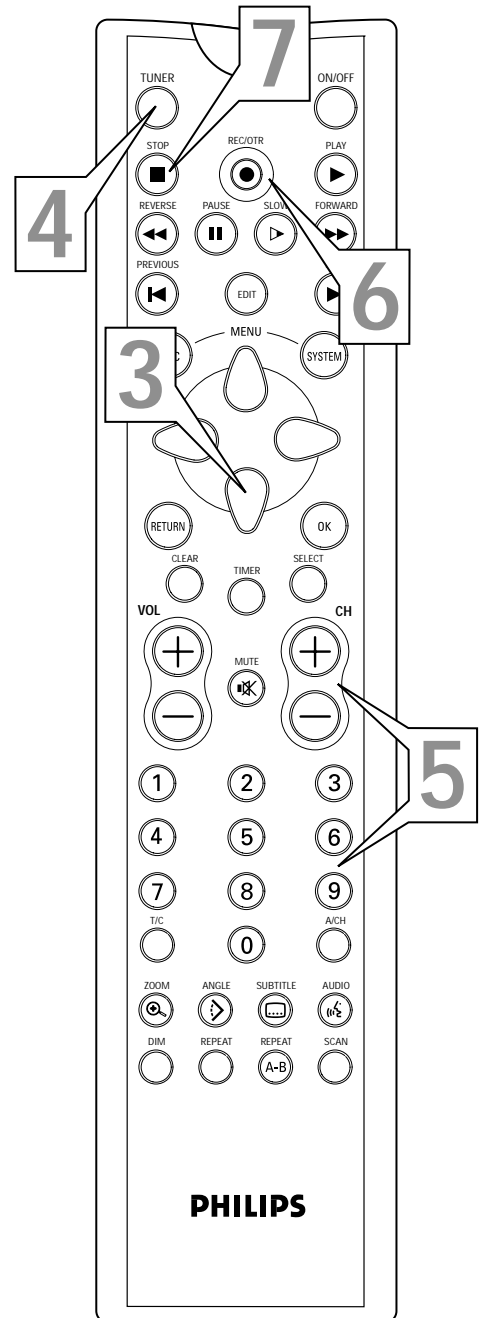

PHILIPS

20 Remote Control Buttons

TUNER Button
Press to choose disc mode or tuner mode. In disc mode, use the Index Picture Screen, view Disc playback, or make recordings. In tuner mode, watch or record TV channels through the DVD Recorder. *Details are on page 19.*

STOP ■ Button
Press to stop Disc playback or recording. Press and hold the STOP ■ button for three seconds to open or close the Recorder's disc tray.

DISC MENU Button
Press during playback to access a DVD's Title or Disc menu or the Index Picture Screen of a DVD+RW. *Details are on page 28.*

▼ ▲ ◀ ▶ Buttons
Press to select items. *Details are on pages 25, 28, and 35.*

RETURN Button
Press to go back to a previous menu.

VOL (volume) +/- Buttons
Press to increase or decrease the TV volume. *Details are on page 60.*

MUTE Button
Press to silence the TV volume. Press again to restore the volume. *Details are on page 60.*

ZOOM Button
Press to access (Zoom) in the Menu Bar and enlarge the video image during paused or regular playback of a DVD or DVD+RW. *Details are on page 30.*

DIM Button
Press repeatedly to adjust the brightness of or to turn off the display on the front of the DVD Recorder.

ON/OFF Button
Press to turn on or off the power of the DVD Recorder. The STAND BY/ON light on the front of the Recorder is green when the power is on. The light is red when the power is off. *Details are on page 22.*

REC/OTR Button (Record/One-Touch Recording)
Press to record the current TV channel as seen in Tuner mode. Or, press to start recording material that is playing on equipment connected to the Recorder (after choosing the correct EXT or CAM channel). *Details are on page 19.* Press repeatedly to set up One-Touch Recordings. *Details are on page 40.*

SYSTEM MENU Button
Press to access or remove the Menu Bars of the DVD Recorder. *Details are on page 25.*

OK Button
Press to acknowledge or approve a menu selection.

SELECT Button
Press to select an AM or PM Start or End time for a timer recording. *Details are on page 41.*

TV Switch
Press and hold while using buttons on the remote control that operate your TV. *Details are on page 60.*

AUDIO Button
Press to select a different audio language or soundtrack during DVD playback. Multiple languages or soundtracks must be available on the DVD. *Details are on page 29.*

SCAN Button
Press to play the first 10 seconds of each Track or Chapter on a Disc. *Details are on page 33.*

Remote Control Buttons (cont'd) 21

REVERSE ◀◀ Button
Press to search backward, or fast reverse, during playback. Press repeatedly to play the Disc backward at 4 or 32 times the normal speed. *Details are on page 32.*

PREVIOUS ◀ Button
Press to return to the beginning of the current Chapter/Track. Or, press repeatedly to return to the beginning of previous Chapters/Tracks. *Details are on page 28.*

EDIT Button
Press to display or remove the edit menu for a DVD+RW during playback. *Details are on page 48.*

CLEAR Button
Press to delete the last entry of information into a menu. Press to clear a timer recording. *Details are on page 43.*

T/C (Title/Chapter) Button
Press to select "T" (Title/Track) or "C" (Chapter) in the Menu Bar. (Press T/C repeatedly to toggle between T or C in the Menu Bar.) Then press ▼▲ to select the Title, Track, or Chapter number you want to play. The Title/Track/Chapter will start to play automatically. This button has no effect during Tuner mode.

ANGLE ↗ Button
Press to select a different camera angle during DVD playback. Multiple angles must be available on the Disc. *Details are on page 30.*

REPEAT Button
Press repeatedly to play a Chapter, Title, Track, or Disc repeatedly. *Details are on page 34.*

REPEAT A-B Button
Press to set up Repeat A-B playback, in which a certain segment of the Track or Chapter plays repeatedly. *Details are on page 34.*

SLOW ▶ Button
Press repeatedly to select a slow motion speed. You can choose to play the Disc at 1/2, 1/4, or 1/8 the normal speed. *Details are on page 32.*

PLAY ▶ Button
Press to begin Disc playback.

FORWARD ▶▶ Button
Press to search forward, or fast forward, during Disc playback. Press repeatedly to play the Disc forward at 4 or 32 times the normal speed. *Details are on page 32.*

NEXT ▶| Button
Press to skip to the next Chapter or Track during playback. *Details are on page 28.*

PAUSE || Button
Press once to pause playback. Press repeatedly to advance a paused DVD or DVD+RW picture one frame at a time (frame-by-frame playback). *Details are on page 31.*

TIMER Button
Press to access or remove the Timer Recording menu. *Details are on pages 41-43.*

CH (channel) +/- Buttons
Press to select a TV channel in Tuner mode.

Number Buttons
Press to select numbered items in a menu. *Details are on page 18.* Press during playback to directly select a Chapter (within the current Title) or Track for playback. *Details are on page 28.*

A/CH (Alternate Channel) Button
Press to return to the previously selected TV channel while the Recorder is in Tuner mode.

SUBTITLE ☰ Button
Press repeatedly during playback to select a subtitle language from those available on the current Disc. *Details are on page 29.*

22 Front Panel

STAND BY / ON Button and Light

Press the STAND BY / ON button to turn on or off the power of the DVD Recorder. The STAND BY / ON light will be red if the DVD Recorder power is off (standby). The STAND BY / ON light will be green when the power is on.

Remote Sensor

The sensor receives signals from the remote. Point the remote here, not at your TV, when using the remote control to operate the DVD Recorder.

PANEL button

Press to open or close the panel door so you can access additional buttons and jacks on the front panel.

Display

Information about the current status of the Recorder appears here. *Details are on page 23.*

RECORD ● button

Press to begin recording the currently selected TV channel or source. *Details are on page 19.*

PLAY ► button

Press to begin Disc playback.

STOP ■ button

Press to stop playback or recording.

OPEN/CLOSE ▲ button

Press to open or close the Disc tray.

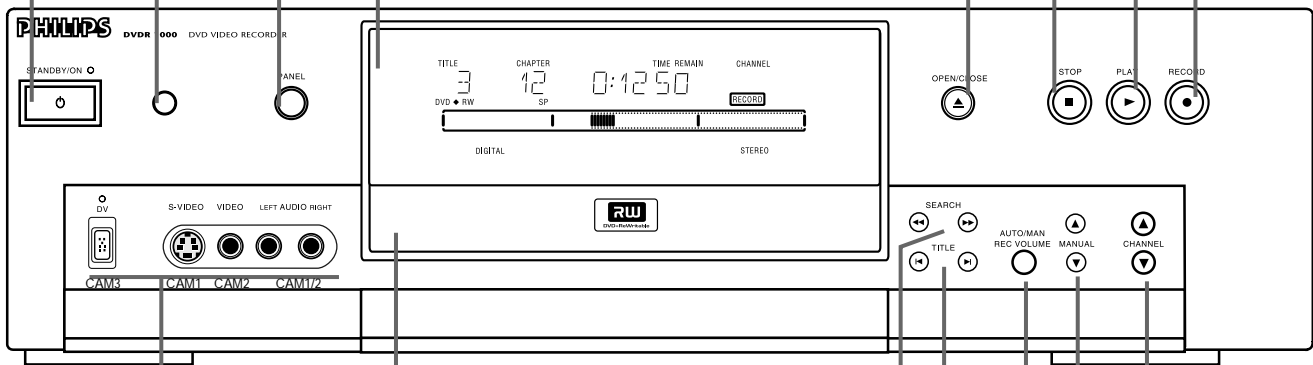

*DV (digital video) iLINK (CAM3); S-VIDEO In (CAM1); VIDEO In (CAM2); and AUDIO In (CAM1/2) jacks

Use these jacks when connecting a camcorder or other equipment to the DVD Recorder. *Details are on page 15.* When recording material that is playing on the other equipment, choose the EXT (External) or CAM (Camera) channel that corresponds to the jack to which the equipment is connected. *Details are on page 19.*

Disc Tray

Insert a Disc here. Load the Disc with the label facing up. *Details are on page 18.*

*SEARCH ◀▶ buttons

Press to begin a reverse or fast forward search during playback. Press repeatedly to search at either 4 or 32 times the regular playback speed. *Details are on page 32.*

*TITLE ◀▶ buttons

Press TITLE ▶ to go to the next Title or Chapter on a Disc. Press TITLE ◀ once to go to the beginning of the current Title or Chapter. Press TITLE ◀ repeatedly to go to previous Titles or Chapters.

*AUTO MAN REC VOLUME button (Automatic/Manual Recording Volume)

Press to adjust the recording volume automatically or manually. *Details are on page 45.*

*MANUAL ▼▲ buttons

Press to increase or decrease the volume when manually adjusting the recording volume. *Details are on page 45.*

*CHANNEL ▼▲ buttons

Press to change TV channels while in Tuner mode.

* Press the PANEL button to lower the panel door to access these buttons or jacks.

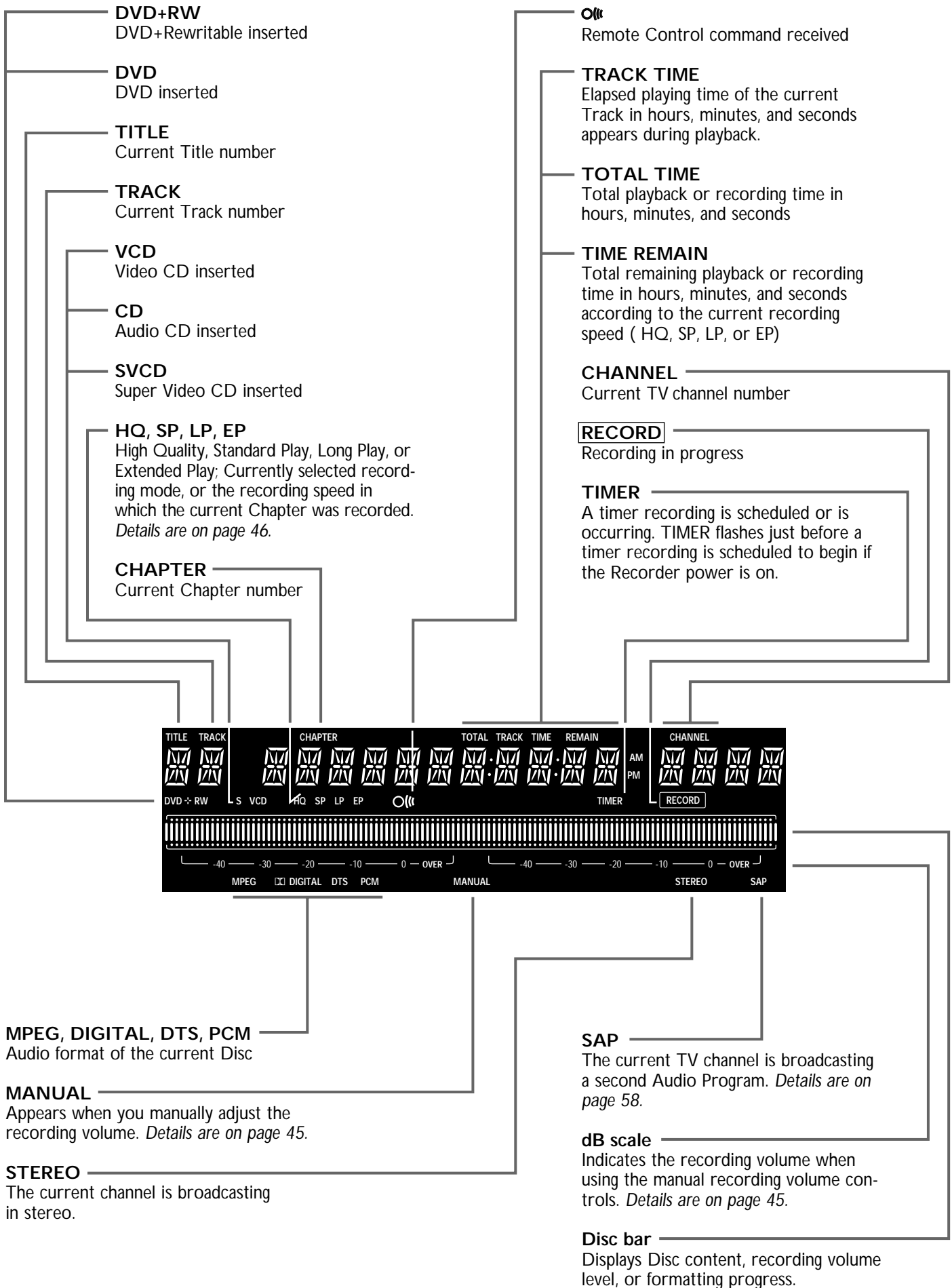

24 Rear Panel

MAINS (AC Power)

Connect the supplied AC power cord here and to a standard AC outlet after completing all other connections.

TV jack

If your television only has a 75 ohm or RF coaxial jack, connect the supplied RF coaxial cable to the TV jack on the DVD Recorder and to the RF IN jack on the TV. You will need an RF modulator. *Details are on page 9.* For more information, refer to your TV owner's manual.

ANTENNA jack

Connect your antenna or Cable TV signal here. *Details are on pages 9-15.*

VIDEO IN (CVBS) jack

Use a video cable to connect this jack to the Video Out jack of other equipment. *Details are on page 15.*

VIDEO OUT (CVBS) (EXT2) jacks

Connect the supplied yellow-striped video cable to one of the VIDEO OUT (CVBS) jacks and to the TV's Video In jack. *Details are on page 12.* Use the extra VIDEO OUT (CVBS) jack to connect the Recorder to other equipment.

IN RC 6 jack

Connect a wired remote control (not supplied) to the IN RC 6 jack if you prefer. Ask your dealer for details on compatible remotes. The first signals from the remote control may be lost. The remote control supplied with the DVD Recorder will operate all the recorder's features.

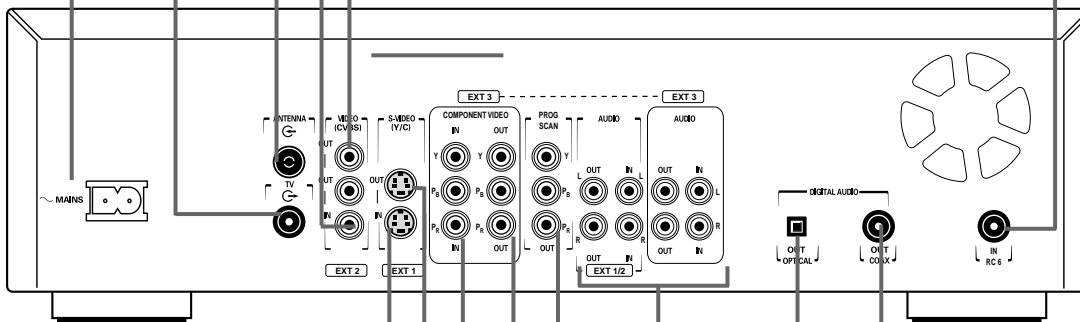

S-VIDEO IN (Y-C) (EXT1) jack

Use an S-video cable to connect this jack to the S-Video Out jack of optional additional equipment. *Details are on page 15.*

S-VIDEO OUT (Y-C) (EXT1) jack

Connect the supplied S-Video cable here and to a TV's S-Video In jack. *Details are on page 11.*

COMPONENT VIDEO IN (Y Pb Pr) (EXT3) jacks

Connect these jacks to the Component Video Out jacks of optional additional video equipment (for example, a DVD Player). *Details are on page 15.*

COMPONENT VIDEO OUT (Y Pb Pr) (EXT3) jacks

Connect the supplied three-strand component video cable here and to the Component Video In jacks of a TV. *Details are on page 10.*

PROG SCAN OUT (Y Pb Pr) jacks (Progressive Scan)

Connect these jacks to a TV's Progressive Scan In jacks if the TV has Progressive Scan. Use the supplied three-strand component video cable. Match the cable stripe colors to the jack colors. If your TV does not have Progressive Scan, use the COMPONENT VIDEO OUT jacks instead. *Details are on page 10.* Also see your TV manual for details.

DIGITAL AUDIO OUT COAX (coaxial) jack

Connect a digital audio coaxial cable here and to the digital audio coaxial In jack of a Stereo. *Details are on page 14.*

DIGITAL AUDIO OUT OPTICAL jack

Connect a digital audio optical cable here and to the digital audio optical In jack of a Stereo. *Details are on page 14.*

AUDIO OUT/ IN (Left/Right) jacks

Use the supplied audio cables (with red and white stripes) to connect the Recorder's AUDIO OUT jacks to the Audio In jacks of a television or Stereo. *Details are on pages 10-13.* Use the AUDIO IN jacks when connecting additional equipment to the DVD Recorder. *Details are on page 15.*

Helpful Hints

- Each Audio and Video jack is labelled EXT1, EXT2, or EXT3. Use the same EXT (external) number for the audio and video connection to the TV. For example, if you use S-VIDEO, which is EXT1, use the EXT1 AUDIO jacks.
- Do not touch the inner pins of the jacks on the rear panel. Electrostatic discharge may damage the unit permanently.
- You only need one audio and one video connection to a TV. You might not use all the jacks.

In addition to using the shortcut buttons on the remote control to select features, you can use the Menu Bars to operate features. You can not access the Menu Bars during recording.

When a Menu Bar is on the screen, press the **▼▲ ◀▶** buttons on the remote control to select an item. The **▼▲◀▶** symbols in the Menu Bar mean more items are available. Press **▼▲ ◀▶** on the remote control to select these items or to change the setting of an item.

Menu Bar 1

***Press SYSTEM MENU once to access Menu Bar 1. The following items are in Menu Bar 1.** Depending on the available Disc features, you may not be able to access each item at all times. Only available features can be selected.



User Preference Settings Set your preferences for audio and video quality, depending on the equipment you connected to the DVD Recorder. Also set up Languages, Access Control, Playback Control, Remote Control, Settings, Installation features, and other DVD Recorder features.



Title Select to choose an available Title or Track for playback. Use the Number buttons or the **▲▼** buttons to select the Title you want. Playback will start automatically.



Chapter Select to choose an available Chapter for playback. Use the Number buttons or the **▲▼** buttons to select the Chapter you want. Playback will start automatically.



Audio Language If the current DVD has multiple audio soundtracks, choose one here. For example, some DVDs let you play the movie in other languages or hear a director's commentary during playback. Check the Disc case for details. *Details are on page 29.*



Subtitle Language If the current DVD has subtitles in multiple languages, select a language here. *Details are on page 29.*



Angle Select to choose a different camera angle, if available, during DVD playback. *Details are on page 30.*



Zoom Select to enlarge the DVD or DVD+RW picture by 1.33, 2, or 4 times the normal size during playback. *Details are on page 30.*

Menu Bar 2

***While in Menu Bar 1, press ▶ repeatedly to move to Menu Bar 2. The following items are in Menu Bar 2.**



Sound Mode Select to choose a sound mode: Stereo (st), Dolby Surround compatible (sur), 3D Sound (3d). *Details are on page 31.*



Frame-by-frame playback Select for forward or reverse frame-by-frame playback of a DVD or DVD+RW. Press **▼**, then press **◀** or **▶** to move the picture backward or forward one frame at a time. *Details are on page 31.*



Slow motion Select to slow the speed of DVD or DVD+RW playback. *Details are on page 32.*



Fast motion Select to play a DVD or DVD+RW forward or backward at four, eight, or 32 times the normal playback speed. Press **▼**, then press **◀** or **▶** to choose a backward (-) or forward speed. *Details are on page 32.*





Time Search Select to enter a specific time within the current Track, Title, or Chapter at which you want playback to begin. *Details are on page 33.*

26 On-screen Symbols, Status Box

On-screen Symbols

The following symbols will appear briefly on the TV screen when you activate some Disc features.

 **Scan** The first 10 seconds of each Chapter/Track will play.
Details are on page 33.

 **Angle** Multiple angles are available.
Details are on page 30.

 **Repeat All** The entire Disc will play repeatedly.
Details are on page 34.

 **Locked** The current Disc is Locked and cannot play.
Details are on pages 49-53.

 **Repeat Title** The current Title will play repeatedly.
Details are on page 34.

 **Safe** The current Disc is authorized for playback.
Details are on pages 49-53.

 **Repeat Chapter** The current Chapter will play repeatedly.
Details are on page 34.

 **"X"** The feature you just attempted is not available on the current Disc or at the current time.







 **Repeat A** Point A for Repeat A-B playback has been entered.
Details are on page 34.

 **Repeat A-B** A segment of the Disc will play repeatedly.
Details are on page 34.

Status Box

The Status Box shows the current status of the Recorder and information about the current Disc, including Disc type, total playing time, and elapsed playing time. Set Status box to On if you want to see the following icons briefly when you access a feature. *Details are on page 54.*

Disc status icons

-  recording
-  stop
-  pause play
-  pause recording
-  fast forward at four times the regular speed
-  fast reverse at four times the regular speed
-  slow motion

Disc type icons

-  DVD+RW
-  DVD-Video
-  Super Video-CD
-  Video-CD
-  no Disc
-  Disc error

Warning box

Appears near the bottom of the screen when appropriate. *Examples and details are on page 43.*



Tuner Information box

Appears on the left side of the TV screen and identifies the current TV channel or Video source you are watching. For example, if EXT1 appears in the Tuner Information Box, you are viewing or recording the material that is playing on the equipment that is connected to the EXT1 AUDIO and VIDEO IN jacks on the rear of the Recorder.

You can not remove the Tuner Information box during TV or video viewing. The Tuner Information box does not appear during recording or Disc playback.

Make sure you have connected an Antenna or Cable TV signal to the ANTENNA jack on the Recorder. *Details are on pages 10-14.* Press TUNER to go into Tuner mode and view the TV channel or playback from other equipment.

Current TV channel



No signal - Channel is not receivable or no equipment is connected to the designated jack.



Copy-protected signal



Timer Information box

Displays the start time or date of the next scheduled timer recording and appears in the Index Picture Screen. It also may appear at the beginning of a timed One-Touch Recording. The Timer Information box does not appear during recording or Disc playback.

Timer recording due today



Timer recording set for another day within the upcoming year

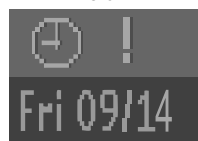

The time at which the current One-Touch Recording will end.



Current time; no timer recordings are scheduled.



28 Title/Disc Menus, Chapter/Track Selection

DVD

DVD+RW

Title/Disc menus

- 1 Press DISC MENU during Disc playback.**
For a DVD, if the current Title has a menu, the Title menu will appear on the screen. Otherwise, the Disc menu will appear. The menu may list camera angles, spoken language and subtitle options, and Chapters for the Title.
For a DVD+RW, the Index Picture Screen will appear.
Details are on page 35.
- 2 Press ▼▲◀▶ to select items in the menu or Index Picture Screen, then press OK.** Continue until you set up all the features you want or until playback begins.

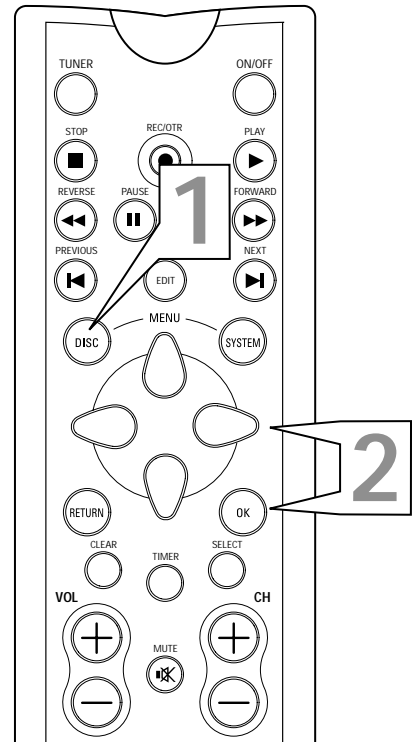

DVD

AUDIO CD

VIDEO CD

DVD+RW

Chapter/Track Selection

- 1 Press NEXT ▶| during playback to go to the next Track/Chapter. Press PREVIOUS |◀ once to return to the beginning of the current Track/Chapter. Press PREVIOUS |◀ repeatedly to step back to previous Tracks/Chapters.**
- 2 To go directly to any Track/Chapter during playback, press the Number buttons to enter the Track/Chapter number.** If you enter an invalid number, an "X" may appear in the top left corner of the TV screen. The current Track/Chapter will continue to play. Or, an incorrect Track/Chapter may begin to play. Make sure the Track/Chapter number you enter is available on the Disc. Make sure the Chapter is available within the current Title. The Menu Bar will disappear automatically in a few seconds.

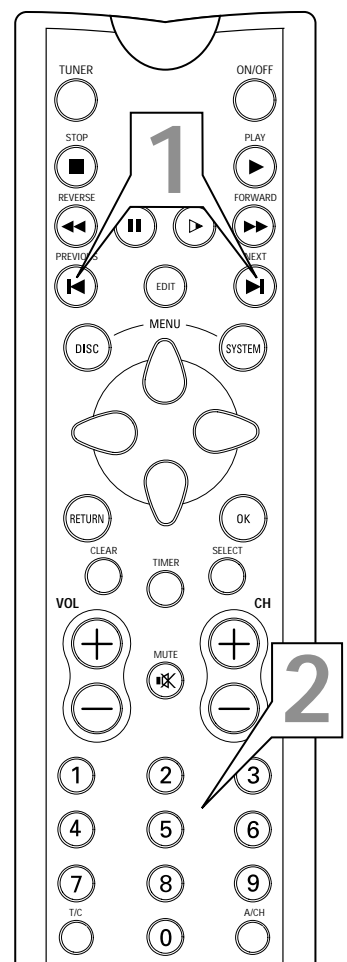

DVD

Audio Language

Some DVDs are recorded in different languages. For example, you may be able to watch the same movie in French, Spanish, etc. The movie may have special audio features, such as a director's commentary or music soundtrack. If these are available on the DVD, access the different languages or featured soundtracks by following these steps.

- 1** During DVD playback, press the **AUDIO** (🔊) button. (🔊 Audio will be selected in the Menu Bar.
- 2** Within five seconds, press the **AUDIO** (🔊) button repeatedly to see the different languages available. Or, press ▲ or ▼ repeatedly to see the different languages. The language you select will be audible in a few seconds. The Menu Bar will disappear automatically in a few seconds.
The languages or options may be abbreviated. For example, French may be Fr. See your Disc case for details on available audio features and explanations.

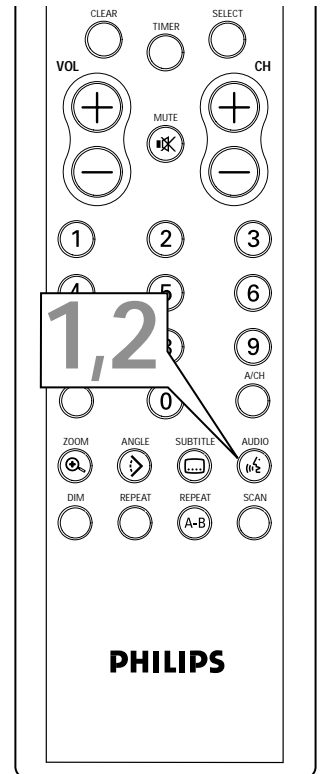
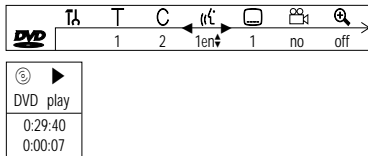

DVD

DVD+RW

Subtitles

Some DVDs include subtitles in different languages. Or, material you recorded onto a DVD+RW might include subtitles. To choose subtitles, follow these steps.

- 1** During playback, press the **SUBTITLE** (☰) button. (☰ Subtitle) will be selected in the Menu Bar.
- 2** Within five seconds, press the **SUBTITLE** (☰) button repeatedly to see the different subtitle languages. Or, press ▲▼ to see the different subtitle languages. Subtitles will appear after a few seconds. The Menu Bar will disappear automatically in a few seconds.
You can choose subtitles only if they are available on the Disc.

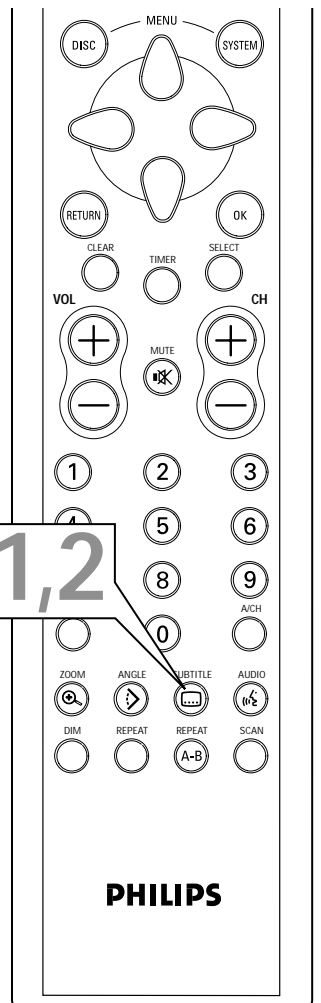
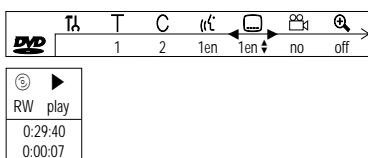



30 Zoom, Camera Angle

DVD VIDEO CD DVD+RW

Zoom

Zooming lets you enlarge the video image during playback and pan through the enlarged image.

- 1 Press **ZOOM**  during Disc playback.  Zoom will be selected in the Menu Bar.
- 2 Within five seconds, press **▲** or **▼** to choose 1.33, 2 or 4. Playback will pause, and the still picture will appear at 1.33, 2, or 4 times the normal size.
- 3 To move the enlarged picture around on the TV screen, or "pan," press **OK**. Then, press **▼ ▲ ◀ ▶** to move the picture.
- 4 Press **OK** again to see the still, zoomed picture without the Menu Bar.
- 5 To return to regular playback, press **PLAY** .
- 6 Press **SYSTEM MENU** to remove the Menu Bar again.

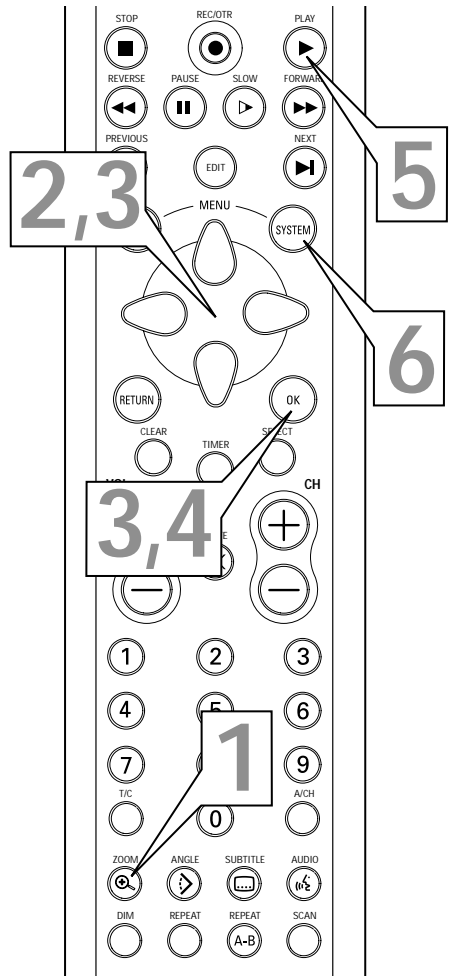
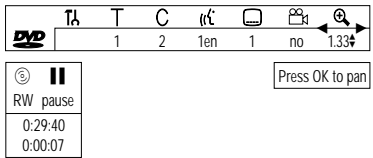

DVD

Camera Angle

Some DVDs include scenes recorded from different angles. To watch segments from a different angle, follow these steps.

- 1 During DVD playback, press the **ANGLE** button. Angle will be selected in the Menu Bar.
- 2 Within five seconds, press **▲▼** to select a different angle. In a few seconds, playback changes to the selected angle.
 - Or, if the Angle symbol appears in the top left corner of the TV screen during playback, multiple angles are available. Simply press **▲▼** to switch among the different angles.

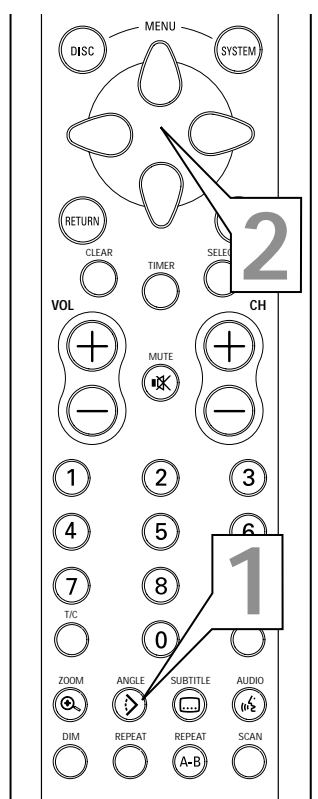
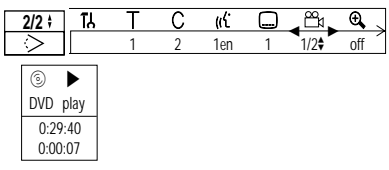

Sound, Still Picture/Frame-by-Frame Playback 31

Sound

Choose a sound setting based on the capabilities of the equipment to which you connected the DVD Recorder. *Details are on pages 9-14 and 57.*

- 1 Press **SYSTEM MENU**.
- 2 Press **▶** repeatedly to select .
- 3 Press **▲▼** to select **st (stereo)**, **sur (surround)**, or **3d**.
 - Select Stereo if your audio equipment is not compatible with either Dolby Surround or TruSurround, or if you connected the DVD Recorder to a Stereo TV only.
 - Select Dolby Surround compatible if your audio equipment is compatible with Dolby Surround. If it is, usually a Dolby Pro Logic logo will appear on the equipment.
 - Select 3D if the audio equipment is TruSurround compatible. Again, the audio equipment likely will be labeled with the TruSurround logo.

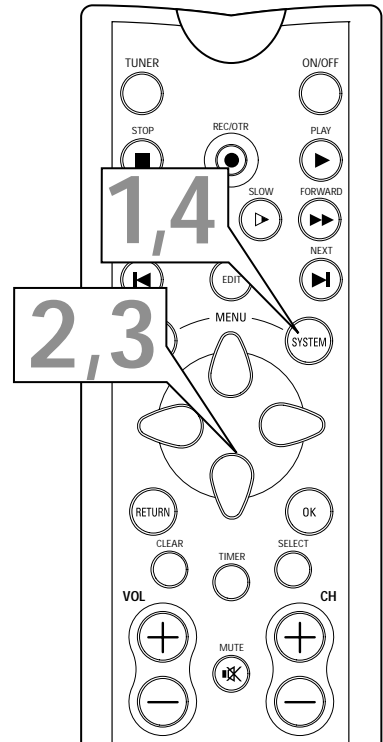
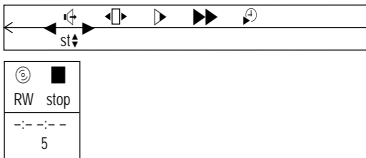

- 4 Press **SYSTEM MENU** to remove the Menu Bar.

DVD DVD+RW

Still Picture/Frame-by-frame Playback

To quickly pause playback, press **PAUSE ■■** on the remote control during playback. To advance the still picture one frame at a time, press **PAUSE ■■** repeatedly. To resume play, press **PLAY ▶**.

Or, to freeze the picture during Disc playback using the Menu Bar, follow the steps below.

- 1 Press **SYSTEM MENU** during playback.
- 2 Press **▶** repeatedly to select .
- 3 Press **▼** to freeze the picture, then press **◀▶** to move the picture backward or forward one frame at a time. Do not leave a still picture on your TV more than five minutes. This may etch the image onto your screen permanently. Other still visual elements, such as TV station logos or video games, also will damage your TV screen if left too long.

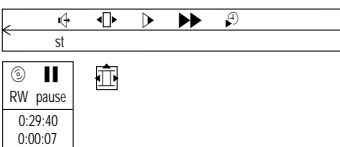

- 4 Press **PLAY ▶** to resume regular playback.
- 5 Press **SYSTEM MENU** to remove the Menu Bar.

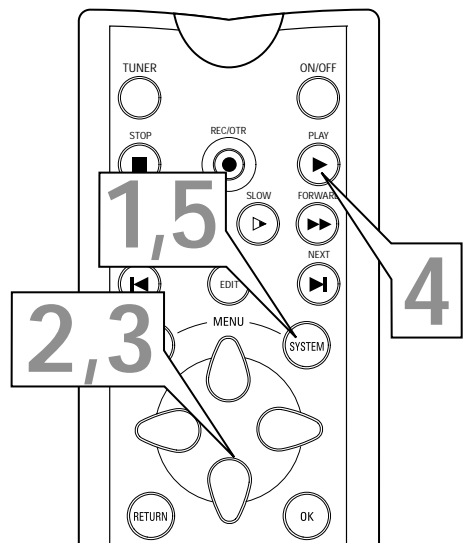

Helpful Hint

- The Recorder also refers to Sound settings as Analog Output. This means the sound the Recorder sends to your audio equipment (stereo receiver) is analog, or two-channel, left and right. You know you are using analog sound because you used the red and white, left and right, Audio jacks in your connections. Details are on page 57. Whether you adjust the sound settings here or as described on page 57, the results will be the same.

32 Slow Motion, Forward and Reverse Searching

DVD DVD+RW

Slow Motion

Start slow motion playback simply by pressing the SLOW ▶ button during playback. Press SLOW ▶ repeatedly to play the Disc at 1/2, 1/4, or 1/8 the regular speed.

Or, to use the Menu Bar for slow motion, follow the steps below.

- 1 During Disc playback, press SYSTEM MENU.
- 2 Press ▶ repeatedly to select ▶ (Slow motion), then press ▼. Playback will pause.
- 3 Press ◀▶ to select the required speed: -1, -1/2, -1/4 or -1/8 (backward), or 1/8, 1/4, 1/2 or 1 (forward). The Disc will start to play at the speed you selected, for example, one-half as fast as normal (1/2).
Select 1 to play the Disc at normal speed again. Select 0 or press PAUSE ■■ on the remote control to pause the picture.

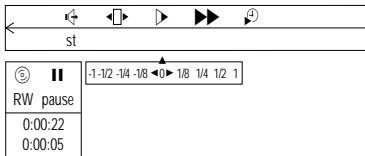

- 4 To return to normal playback, press PLAY ▶.
- 5 Press SYSTEM MENU to remove the Menu Bar.

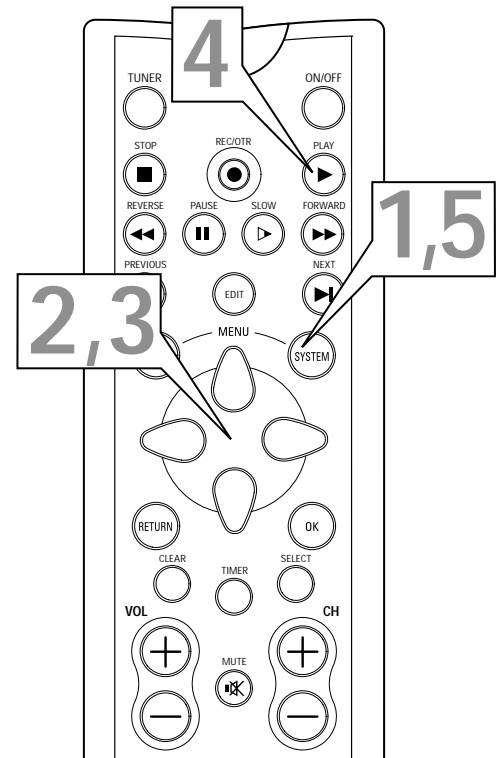

DVD AUDIO CD VIDEO CD DVD+RW

Forward and Reverse Searching

- 1 To search a DVD, Video CD, or DVD+RW at four times the normal speed, press FORWARD ▶▶ or REVERSE ◀◀ during playback. To search at 32 times the normal speed, press FORWARD ▶▶ or REVERSE ◀◀ again. The sound will be mute. On an Audio CD, to search the Disc at four times the normal speed, press FORWARD ▶▶ or REVERSE ◀◀ during playback. Sound will be muted partially. To search at eight times the normal speed, press FORWARD ▶▶ or REVERSE ◀◀ again. The sound will be mute. Each press of FORWARD ▶▶ or REVERSE ◀◀ switches between the slower and faster search speed.

- 2 Press PLAY ▶ to resume playback or press STOP ■ to stop playback.

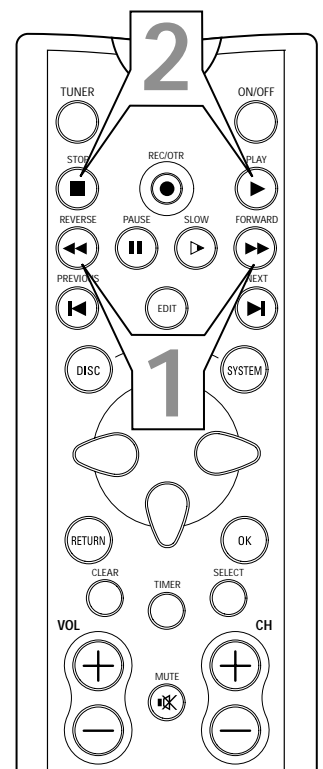

DVD VIDEO CD DVD+RW

Time Search

Time Search lets you choose a specific time at which you want to begin playback.

- 1 Press **SYSTEM MENU** during Disc playback.
- 2 Press **▶** repeatedly to select **4**.
- 3 Press **▼**. Playback will pause. A time edit box will appear, showing the elapsed playing time of the current Chapter or Disc.

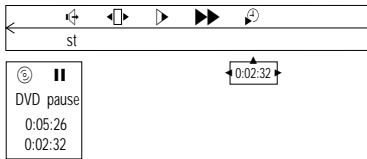

- 4 Press the **Number** buttons to enter the time at which you want playback to begin. Enter the hour, minutes, and seconds from left to right in the box. The time must be within the possible time frame of the current Chapter or Disc. If it is not, play will not begin after you press OK at step 5. Instead, the first space in the time edit box will blink. Reenter a correct time.
- 5 Press **OK**. After a few seconds, playback will resume at the point you selected.
- 6 Press **SYSTEM MENU** to remove the Menu Bar.

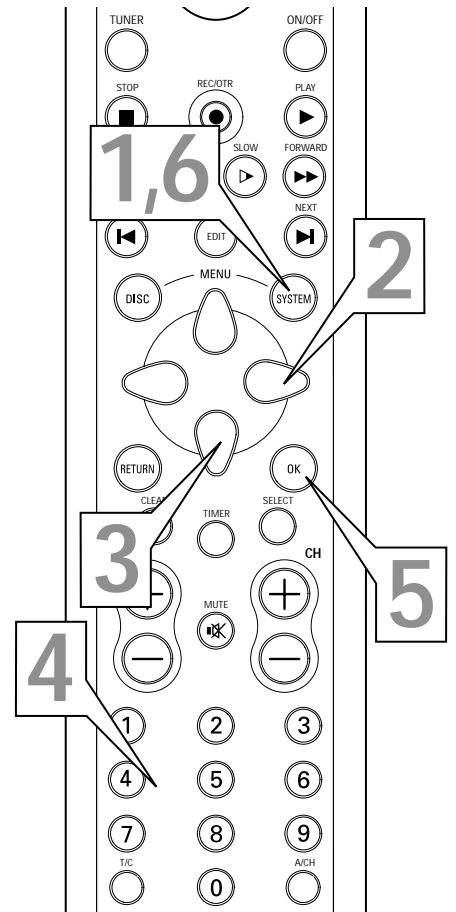

DVD AUDIO CD VIDEO CD DVD+RW

Scan

Scanning plays the first 10 seconds of each Chapter/Track on the Disc.

- 1 Press **SCAN** during playback. Starting at the beginning of the current Chapter/Track, the first 10 seconds of each Chapter/Track will play. This will continue until the end of the Disc is reached or you resume regular playback.
- 2 To continue regular playback from a Chapter/Track, press **SCAN** again or press **PLAY ▶**.

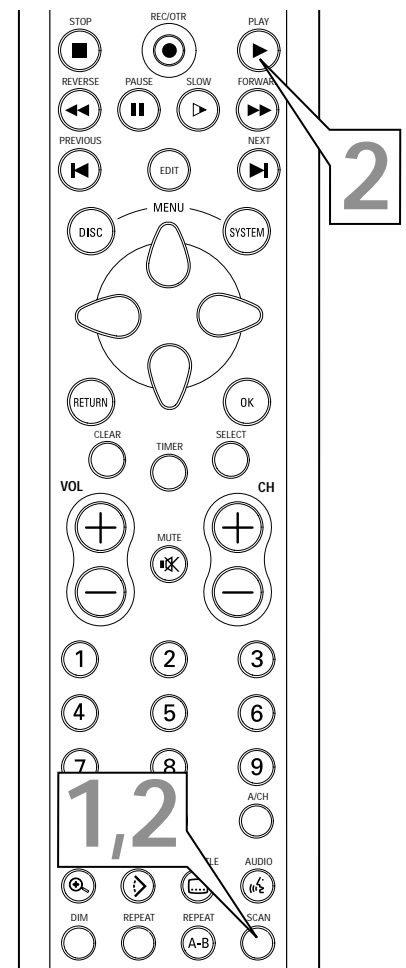

34 Repeat, Repeat A-B

DVD AUDIO CD VIDEO CD DVD+RW

Repeat

You may play a Chapter, Track, Title or entire Disc repeatedly.

- 1** During Disc playback, press **REPEAT** repeatedly to choose a **Repeat option**. Depending on the type of Disc, you may choose to play the Chapter, Track, Title, or Disc repeatedly. During DVD, Video CD, or DVD+RW playback, the repeat symbols will appear briefly on the TV screen. *Details are on page 26.* A DVD+RW will play repeatedly only if the Disc is full of recordings.
- 2** To cancel repeat playback, repeatedly press **REPEAT** until all the repeat symbols or messages disappear from the screen.

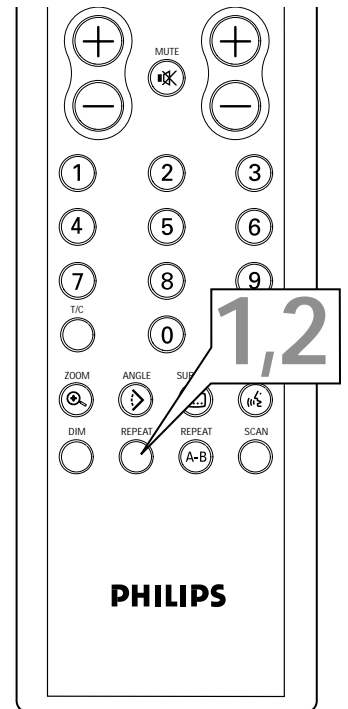

DVD AUDIO CD VIDEO CD DVD+RW

Repeat A-B

You also may set the DVD Recorder to play only a specific portion of a Title, Chapter, or Track repeatedly. Follow these steps.

- 1** Press **PLAY** ▶ to start Disc playback.
- 2** When the Disc reaches the point at which you want repeated playback to begin, press **REPEAT A-B**.
- 3** When the Disc reaches the point at which you want to end the segment, press **REPEAT A-B** again. The segment will begin playing repeatedly.
- 4** To resume regular playback, press **REPEAT A-B** again. Regular playback will resume from the current point.

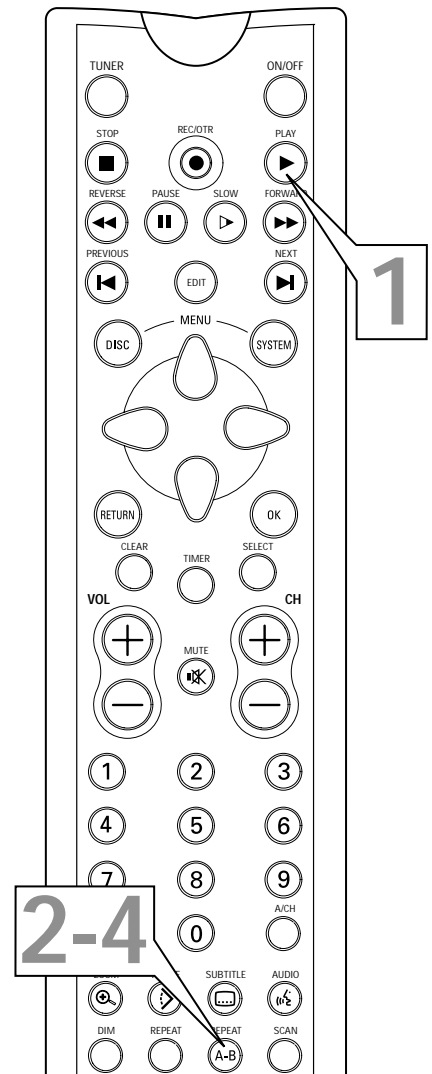

The Index Picture Screen shows the Titles you have recorded on a DVD+RW. It appears automatically when you stop playback or recording and a DVD+RW is in the Recorder. (The DVD+RW must contain recorded content.)

An Index Picture represents each Title. Next to the Index Picture is the program name, length of recording, recording mode/speed, and date of recording. If the Title has no name, the recording source and time will appear instead (for example, the recorded channel) and the time at which you started recording the channel.

Empty disc areas (erased Titles or blank space at the end of the Disc) also appear in the Index Picture Screen. "Empty title" and the amount of remaining recording time appear beside the empty Index Picture box.

The Index Picture Screen will dim after several minutes of no use. To brighten it again, press any button on the DVD Recorder or its remote control.

Titles

A maximum of three Index Pictures appears on the screen at once. Press ▲▼ to move to additional Titles if available.

Press STOP ■ briefly to move directly to the first Title on the Disc.

Press and hold NEXT ► to move quickly to the last recorded Title on the Disc or to the last Empty Title.

Disc Bar

The Disc Bar appears at the right of the Index Picture Screen. This overviews all titles on the Disc, as well as any empty spaces.

On the Disc Bar, an arrow indicates your current position on the Disc. Moving through the Titles by pressing ▲▼ moves the arrow. You may resume playback or recording from this point by pressing OK for playback or REC/OTR for recording.

Title Settings Menu

When you select an Index Picture, press ► to go to the Title Settings menu for that Title. Here, you can edit the current Title name, play the entire Title, or erase the selected Title. *Details are on page 44.*

Title description:

Includes program name, length of recording and the speed in which it was recorded, and the date of recording (if clock was set).

Cue: Go to Disc Information Screen or to Title on previous screen. *Details are on page 47.*

Index Picture:

An image representing a recorded Title. An empty box represents an area on the Disc that is empty and available for recording. *To personalize the Index Picture, see page 48.*

Timer Information

Box: Displays the current time or the time/date of the next scheduled timer recording. *Details are on page 27.*

Tuner Information

Box: Displays the currently selected TV channel or video source (if additional equipment is connected to the DVD Recorder). *Details are on page 27.*

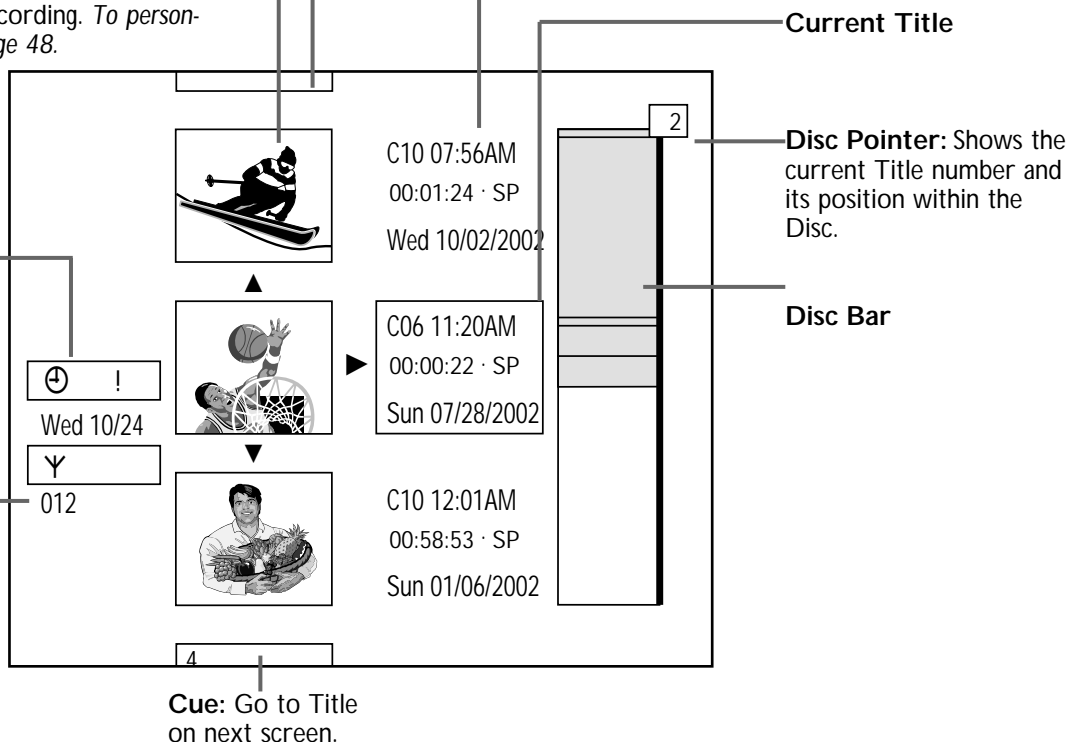

36 Installation: Automatic Channel Programming

Although the DVD Recorder selects available TV channels during Initial Setup, you may want to repeat the process later if more channels become available in your area. This will erase and replace all previously stored channels. To update the available channels, follow these steps.

1 Press **SYSTEM MENU**. may be selected. If it is not, press to select it.

2 Press repeatedly to select , then press to enter the Installation menu.

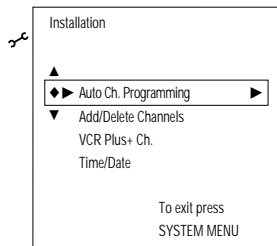

3 Press to select **Auto Ch. Programming**, then press **OK**. "Searching for TV channels" will appear, along with a scale showing channels that are being memorized. The number of channels found will show on the screen as the searching progresses. This will take a few minutes, depending on the number of channels available.

4 When the channel search finishes, "Auto ch. search complete" will appear, along with the total number of channels found. Press **SYSTEM MENU**. The Installation menu will reappear. If you are satisfied with the channels found, press **SYSTEM MENU** again to remove the menu. You are finished. To add or delete additional channels, press to select **Add/Delete Channels**, then go to step 5.

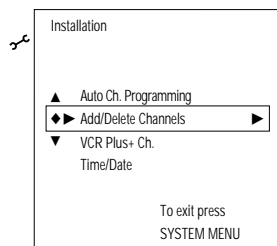

5 Press . A channel list will appear. Beside each channel number, you will see "Del" for deleted or "Add" for added.

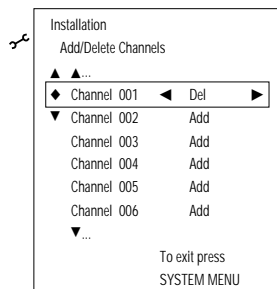

6 Press to select the channel number you want to add or delete, then press to choose Add or Del for that channel. Press **OK** to store your choice. Repeat step 6 as often as necessary to add or delete all the channels you want.

7 Press **SYSTEM MENU** repeatedly to remove all the menus when you are finished.

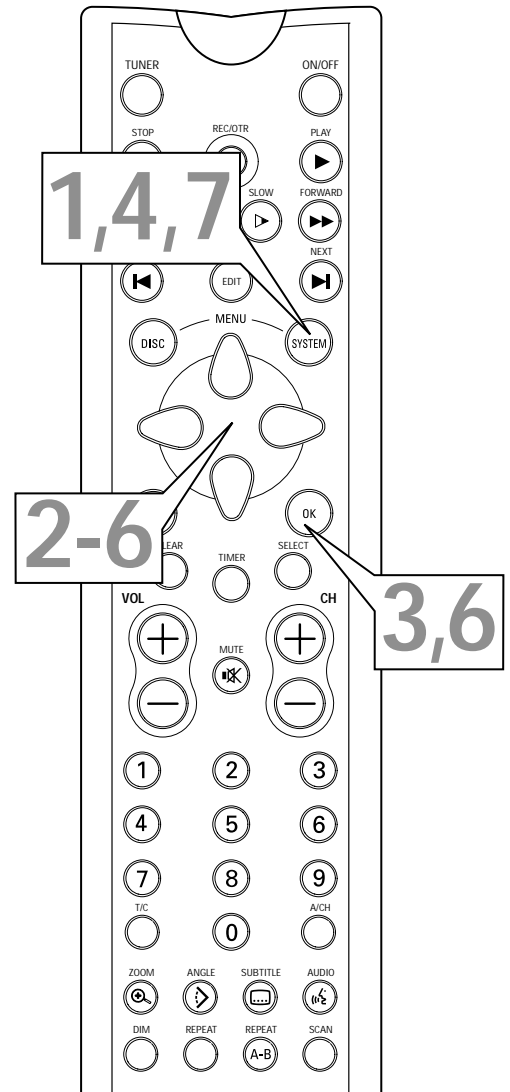

Helpful Hints

- Channels you add will be accessible through the DVD Recorder when you press the CH +/- buttons on the remote while in Tuner mode. Channels you delete will be skipped when you press the CH +/- buttons. So, delete channels you rarely watch. This will quicken channel changing when you use CH +/- . You still can select the deleted channels by pressing the Number buttons on the remote while in Tuner mode.
- If new channels become available in your area, or if you receive a channel that the Recorder did not program automatically during setup, add the channel. The channel will be accessible when you press the CH +/- buttons.

If you intend to use the VCR Plus+ programming system, program the DVD Recorder with your local channel information. This will only take a few minutes. Since the channel numbers of the stations you receive may not be the same as the station numbers, and since channel numbers differ from area to area, you must set up channels in order for the system to work efficiently.

Before you begin, make sure you have 1) a cable channel list, if applicable (you can request one from your cable company), and 2) a chart that lists VCR Plus+ channel numbers, which you can find in your TV guide or the TV listings of your local newspaper.

- 1** Press **SYSTEM MENU**. may be selected. If it is not, press to select it.
- 2** Press repeatedly to select , then press to enter the Installation menu.
- 3** Press to select **VCR Plus+ Ch. (channel)**, then press .

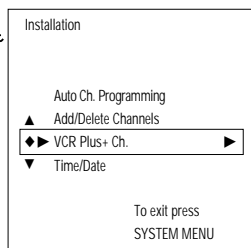

- 4** Press to select a **VCR Plus+ Ch. number**, then press the **Number buttons** or to enter the corresponding **Channel number from your TV guide list**. If you use the Number buttons, enter the channel number as a three-digit number. For example, for channel 18, press 0,1,8. Refer to the list from your local newspaper or TV guide for the VCR Plus+ channels and corresponding TV channel numbers for your area. These are the numbers you will enter as the Channel number as you complete the chart on the screen.

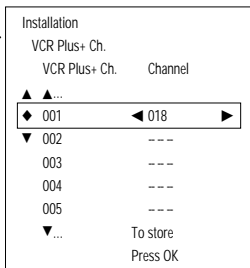

- 5** Press **OK** to store the **Channel number**. Repeat steps 4-5 as often as necessary to complete the chart.
- 6** When you are finished, press **SYSTEM MENU** repeatedly to remove all the menus.

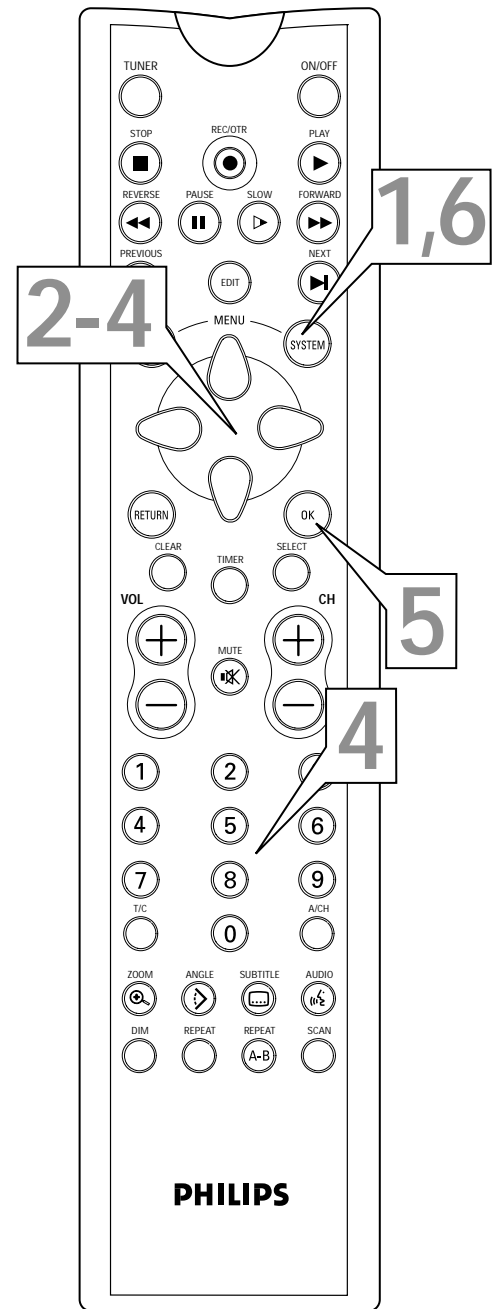

38 Installation: Clock Setting

Time/Date Automatic

The Recorder can set the time and date automatically by referring to your local PBS station. If the Recorder chooses an incorrect PBS channel or sets the time/date incorrectly, you can set the information manually. *Details are on page 39.*

Before you begin, make sure TV channels are set. *Details are on page 36.*

- 1 Press **SYSTEM MENU**. may be selected. If it is not, press **◀** to select it.
- 2 Press **▼** repeatedly to select , then press **▶** to enter the Installation menu.
- 3 Press **▼** repeatedly to select **Time/Date**, then press **▶**.
- 4 Press **▲▼** to choose **Automatic**, then press **▶**.
- 5 With **PBS Channel** selected, press **◀▶** to choose the channel number of your PBS station, then press **OK**. If you do not know your PBS channel number, choose **Auto**.

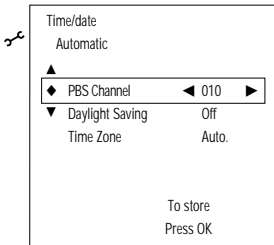

- 6 Press **▼** to choose **Daylight Saving**. Press **◀▶** to choose **On**, **Off**, or **Auto**, then press **OK**.

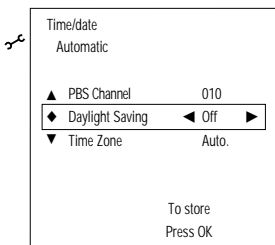

- 7 Press **▼** to choose **Time Zone**. Press **◀▶** repeatedly to choose your time zone, then press **OK**.
If you want the Recorder to use the time zone from which your PBS station broadcasts, choose **Auto**. If your PBS station broadcasts from a different time zone than the one in which you live, be sure to select your time zone.

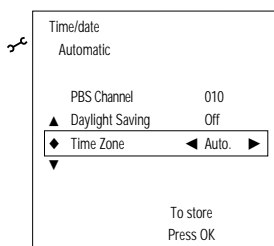

- 8 Press **SYSTEM MENU** repeatedly to remove the menus, then press **ON/OFF** to turn off the Recorder. After a few minutes, the correct time will appear in the display panel on the front of the Recorder.

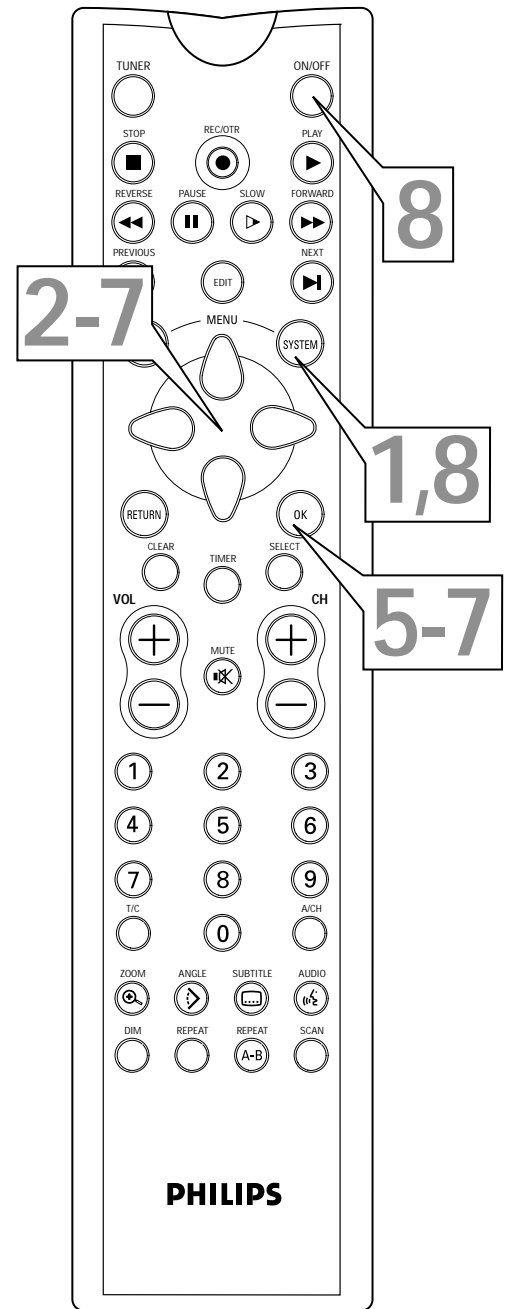

Time/Date Manual

If the Recorder does not set the time and date correctly using the Time/Date Automatic feature, set the clock manually by following the steps below.

- 1 Press **SYSTEM MENU**. may be selected. If it is not, press to select it.
- 2 Press repeatedly to select , then press to enter the Installation menu.
- 3 Press repeatedly to select **Time/Date**, then press .
- 4 Press to choose **Manual**, then press .

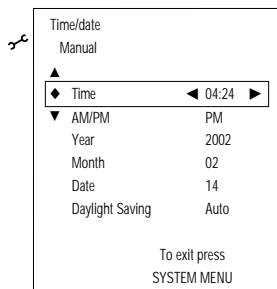

- 5 Time will be highlighted. Press to choose the correct time in hours and minutes, then press **OK**. Or, press the Number buttons to quickly enter the time in hours and minutes, then press **OK**.
- 6 Press to choose **AM/PM**, then press to choose **AM** or **PM**. Press **OK**.
- 7 Press to choose **Year**, then press to choose the current year. Press **OK**.
- 8 Press to choose **Month**, then press to choose the current month. Press **OK**.
- 9 Press to choose **Date**, then press to choose the current date. Press **OK**.
- 10 Press to choose **Daylight Saving**, then press to choose **On**, **Off**, or **Auto**. Press **OK**.
- 11 Press **SYSTEM MENU** repeatedly to remove all menus.

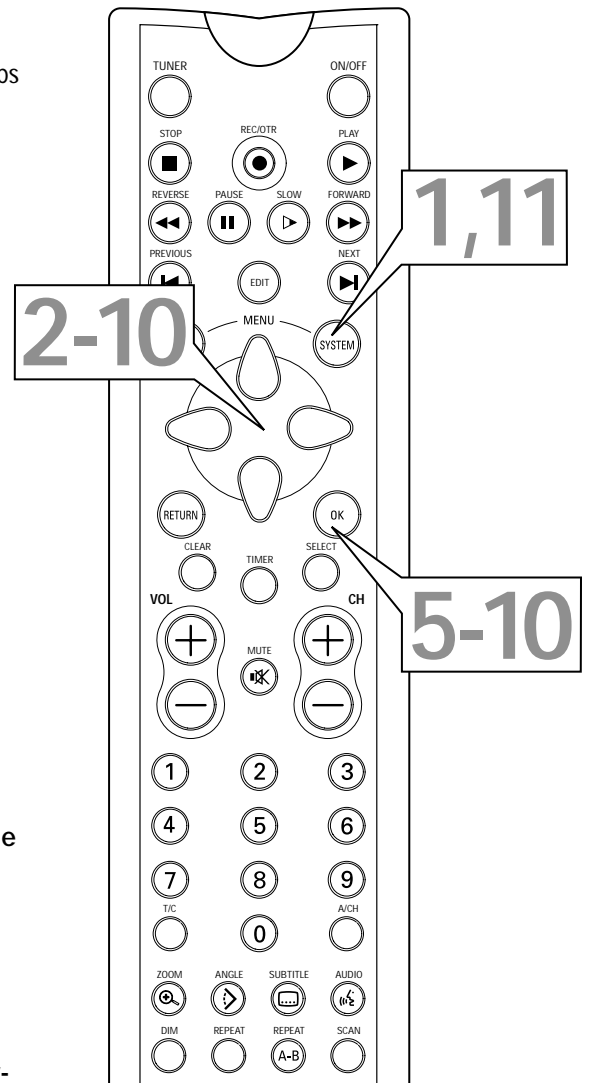

Helpful Hints

- In order for the clock to remain set as you specified manually, set Daylight Saving to Off.
- To keep the automatic clock from overriding your manual clock setting, set PBS Channel to an incorrect PBS station. Details are on page 38.
- If you set up channels again as described on page 36, you must reset your clock.
- When you set the clock manually, you may see an error message every time you turn on the Recorder, indicating that the clock is not set. If the time you set appears on the Recorder's display, disregard the error message.

40 One-Touch Recording

- 1** Insert a recordable DVD+RW into the Recorder.
Details are on pages 18 and 22.
- 2** In the Index Picture Screen, press **▲▼** to select an empty Title (or empty Index Picture box) on the Disc that has enough remaining recording time for the recording. *Details are on page 35.*
- 3** Press **TUNER** to see TV channels through the DVD Recorder. Make sure you have programmed channels. *Details are on page 36.*
- 4** Press **CH+**, **CH-** or the **Number** buttons to select the channel you wish to record.
- 5** Press **REC/OTR** twice to start a 30-minute recording. Press **REC/OTR** repeatedly to record longer timed recordings, up to four hours long in thirty-minute increments.
- 6** Press **STOP** ■ if you need to stop the recording before the designated end time. Otherwise, the Recorder will automatically stop recording at the designated end time and turn itself off.

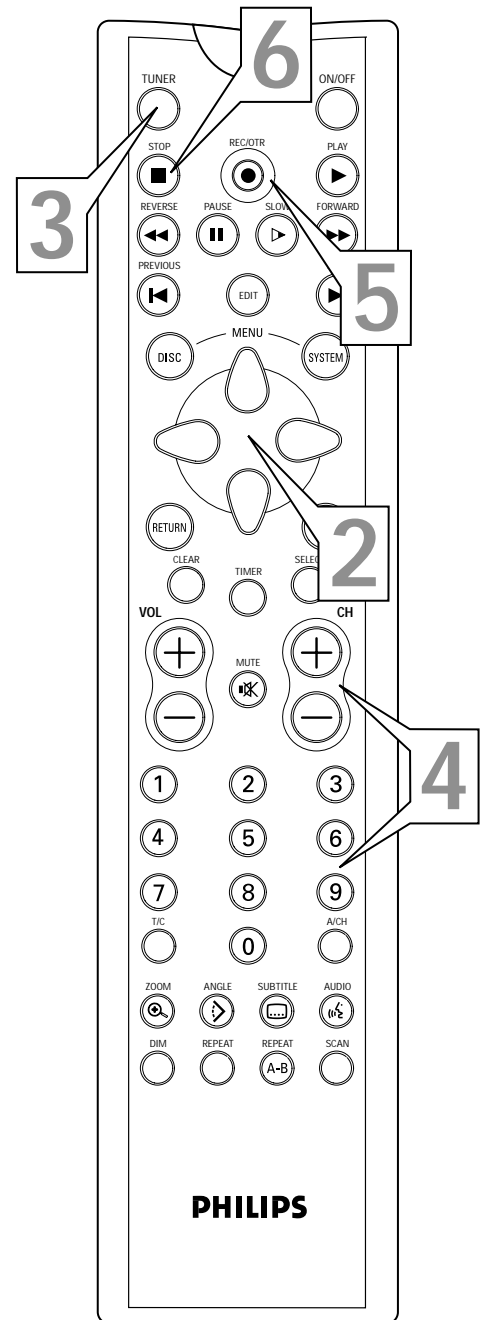

Helpful Hints

- You cannot set a timed recording of a length that will exceed the remaining recording time of the Disc (at the current speed).
- An 'X' will appear in the top left corner of the screen if a protected DVD+RW is in the Recorder.
- If the power fails during recording, the Index Picture Screen may not match the actual video content on the Disc. The last recorded Title may be lost.

- 1 Press **TIMER** on the remote control.
- 2 Press **▲▼** to select Timer Programming, then press **▶**.

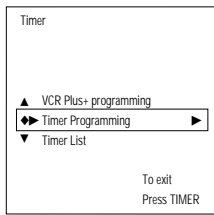

- 3 Date will be selected. Press **▲▼** to enter the month and date you want the recording to start, then press **▶**. Press **SELECT** repeatedly to choose: the date (timer recording will occur once on the day you choose); **Mo-Fr** (timer recording will occur every weekday at the same time); or a **day of the week** (for example, Mo for Monday; timer recording will occur every Monday at the same time).

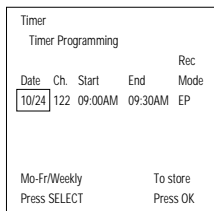

- 4 Ch. (channel) will be selected. Press **▲▼** to enter the channel you want to record, then press **▶**.

- 5 Start will be selected. Press **▲▼** to enter the time at which you want recording to begin - in hours and minutes. Then, press **SELECT** repeatedly to choose AM or PM. When the start time is correct, press **▶**.

- 6 End will be selected. Press **▲▼** to enter the time at which you want recording to stop - in hours and minutes. Then, press **SELECT** repeatedly to choose AM or PM. When the End time is correct, press **▶**.

- 7 Rec Mode (Record Mode) will be selected. Press **▲▼** to choose the speed at which you want recording to occur. Choose **HQ**, **SP**, **LP**, or **EP**.

HQ allows one hour of recording per Disc; SP, two hours; LP, three hours; and EP, four hours. The slower the speed, the more recording time per Disc. EP is the slowest speed. The faster the speed, the better the picture quality. HQ is the fastest speed. *Details are on page 46.*

- 8 Take a minute to check your timer information. If something is incorrect, press **◀▶** to choose the incorrect information. Use **▲▼** to enter the correct data.

- 9 When the information is correct, press **OK**. Stored will appear briefly, then the Timer menu will reappear.

- 10 Press **TIMER** to remove the menu.

- 11 Put a recordable DVD+RW in the Recorder. Press **ON/OFF** to turn off the Recorder a few minutes before the timer recording is set to begin. The Recorder must be off in order for the timer recording to begin. For the timer recording, the DVD Recorder will turn itself on, record, then turn itself off when finished.

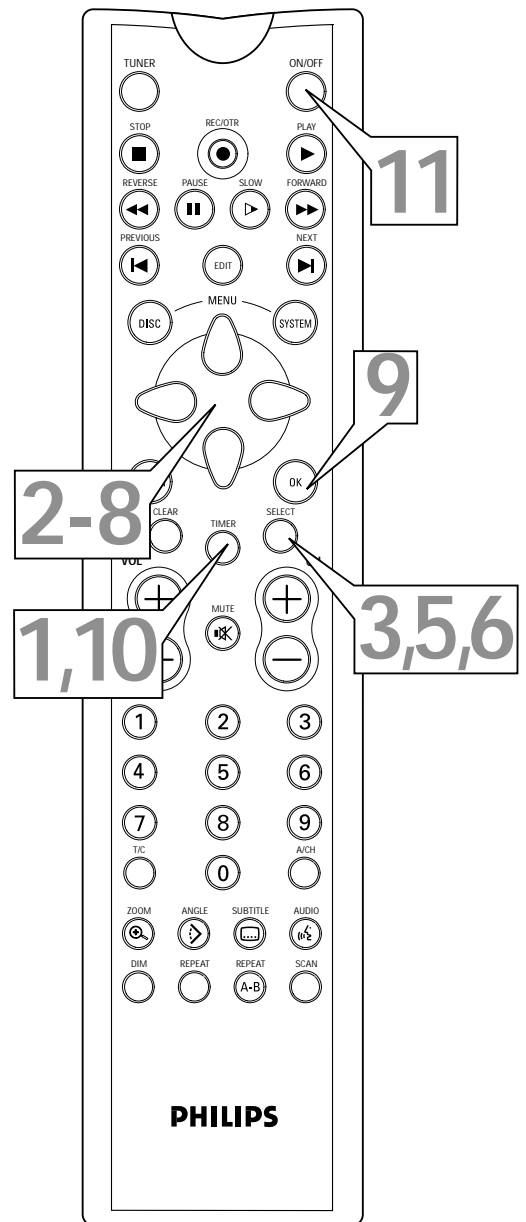

Helpful Hints

- For additional Timer information, see page 43.
- You can enter the information for Date, Channel, Start, and End using the Number buttons. If you do, the next item will be selected automatically.
- When using the Number buttons, enter channel numbers as a three digit number. For example, for channel 15, press 0,1,5.
- To stop a timer recording that is in progress, press **ON/OFF** on the remote control to turn off the Recorder and stop the recording.
- Use **HQ** when recording from digital sources, such as a digital camcorder.

42 VCR Plus+ Timer Recording

A PlusCode is a number of up to eight digits, printed in most TV guides next to the start time of a TV program. You can program a timer recording quickly by simply entering the code for your program. Before you begin, complete the VCR Plus+ channel setup. *Details are on page 37.*

- 1 Press **TIMER** on the remote control.
- 2 Press **▲▼** to select **VCR Plus+ programming**, then press **▶**.

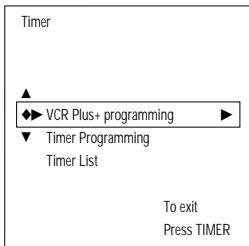

- 3 Press the **Number** buttons to enter the **PlusCode** number from your TV guide, then press **OK**. Information about the timer will appear. If information is missing or not available, you may be asked to enter more information. Follow the instructions given on the screen. If you make a mistake, press **CLEAR** to erase the PlusCode, then enter it again.

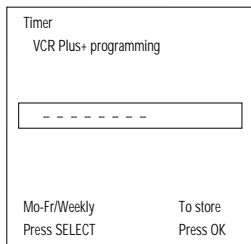

- 4 If the timer recording information seems complete, press **OK**. "Stored" will appear on the screen briefly.

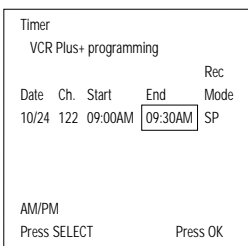

- 5 Press **TIMER** to remove the menu.

- 6 Put a recordable **DVD+RW** in the Recorder. Press **ON/OFF** to turn off the Recorder before the timer recording is set to begin. The Recorder must be off in order for the timer recording to occur.

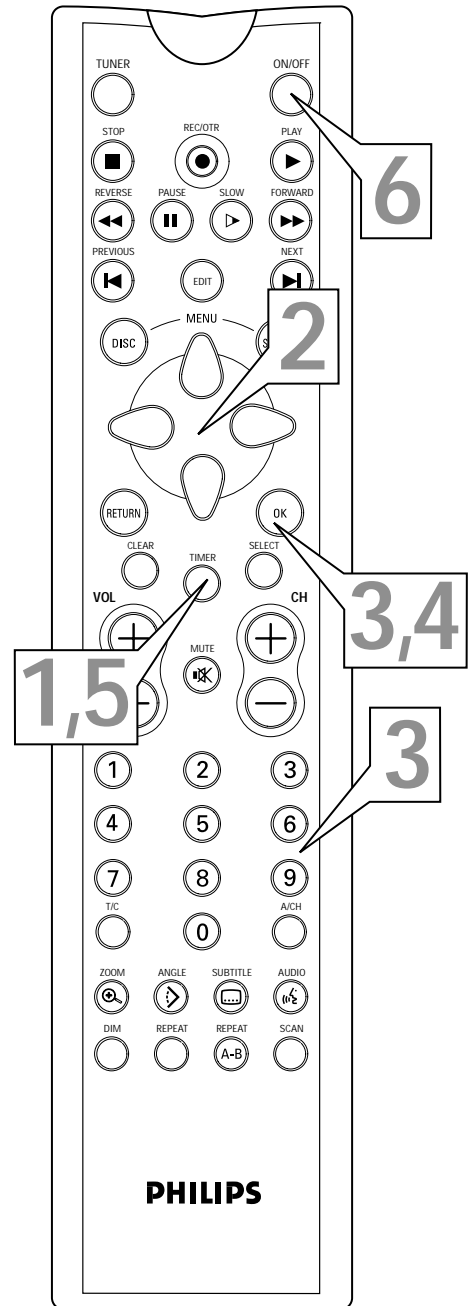

Erasing Timer Recordings

- 1 Press **TIMER**.
- 2 Press **▲▼** to choose Timer list, then press **▶**.
- 3 Press **▲▼** to highlight the timer recording you want to clear.
- 4 Press **CLEAR**. The recording you selected will appear alone on the screen.
- 5 Press **OK** to erase the timer recording. "Timer Cleared" will appear at the bottom of the screen briefly, then the Timer List will reappear. (If you decide not to erase the timer recording, press the **TIMER** button. The Timer List will reappear.)
- 6 Press **TIMER** repeatedly to remove the menus.

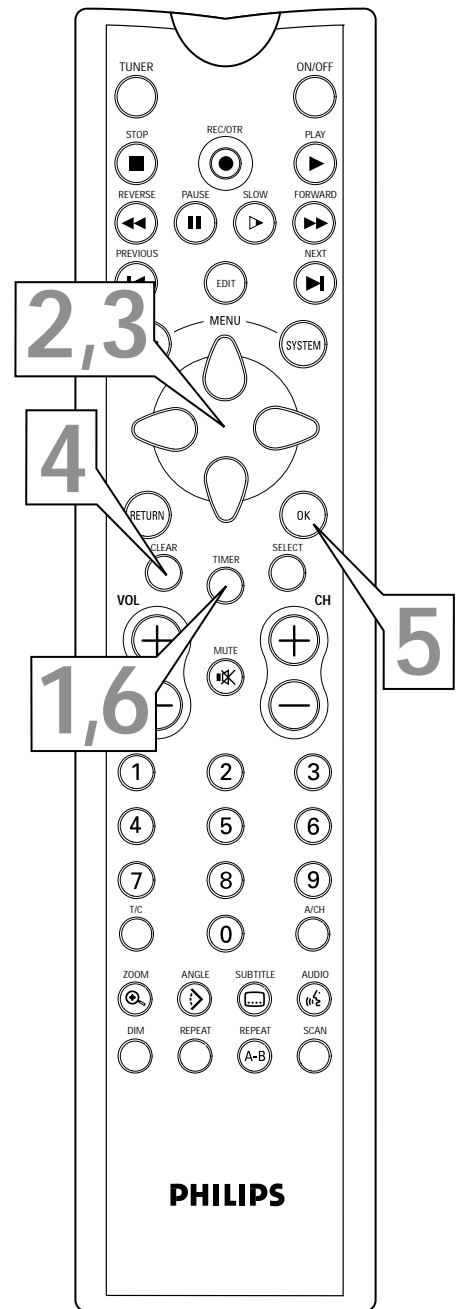

Error Messages

The following messages may appear while you set a timer recording.

Collision

The timer recording overlaps with another timer recording.

- To ignore the message, press **TIMER** again. The program with the earlier start time will record completely, then the remainder of the later program will record.
- Change one or both timer recordings. *Details are on page 41.*
- Delete one of the timer recordings as described above.

Please enter channel number

The VCR Plus+ programming system does not recognize the TV channel.

- Press **◀▶** to select the required VCR Plus+ channel number, then press **OK**. *Details are on page 37.*

PlusCode wrong

You entered an incorrect PlusCode number.

- Enter the correct information or press **TIMER** repeatedly to quit.

Weekend programming -not possible

You entered an incorrect date or chose a daily (Mo-Fr) recording. You can only use daily programming for recordings that will occur Monday, Tuesday, Wednesday, Thursday, or Friday.

Memory full

All the timer blocks are in use. The recorder can store a maximum of six timer recordings at one time.

- Delete one of the timer recordings.

Data error

Make sure all information for the timer recording is correct and complete.

Helpful Hints

- Timer recordings that overlap or conflict with another will appear in a red highlight in the Timer List.
- You may not be able to access the Timer menu if the clock is not set. See pages 38-39 to set the clock.

44 Title Settings Menu

The Title Settings Menu lets you rename a Title that you have recorded onto a DVD+RW. From the same menu, you can also play the entire selected Title or erase the chosen Title from the DVD+RW.

1 When playback is stopped and a DVD+RW is in the DVD Recorder, the Index Picture Screen will appear automatically. *Details are on page 35.*

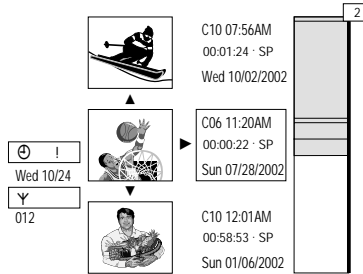

2 Press **▲▼** to select the Index Picture of the Title you want to name, play, or erase, then press **▶**. The Title settings menu will appear.

3 Press **▲▼** to select Name, Play full title, or Erase this title, then continue as directed for each option in step 4.

4

- **Name**
Press **▶**. The first character of the Title name will be selected. Press **▲▼** to change the character. Press **SELECT** to switch between upper and lower case letters. Press **CLEAR** to erase a character. To move to the next or previous character, press **◀▶**. Repeat this process until you have finished naming the Title. **When the Title is complete, press OK.**

- **Play full title**
Press **OK**. The Title you selected will begin to play from its beginning.

- **Erase this title**
Press **OK**. The DVD Recorder will ask you to confirm that you really want to erase the entire Title. **Press OK again to start erasing the Title.** "Erasing title" will appear during erasure. When erasing is complete, the Index Picture Screen will reappear. (If you do not want to erase the Title, press **◀** to return to the Title Settings menu.)

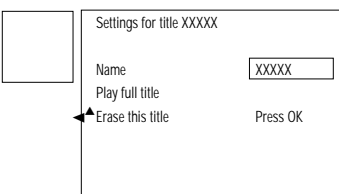
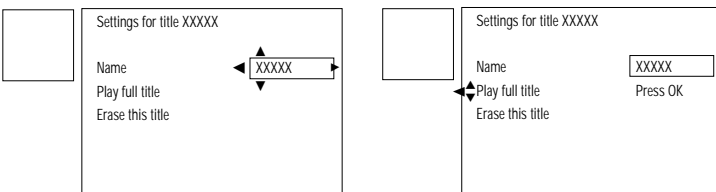
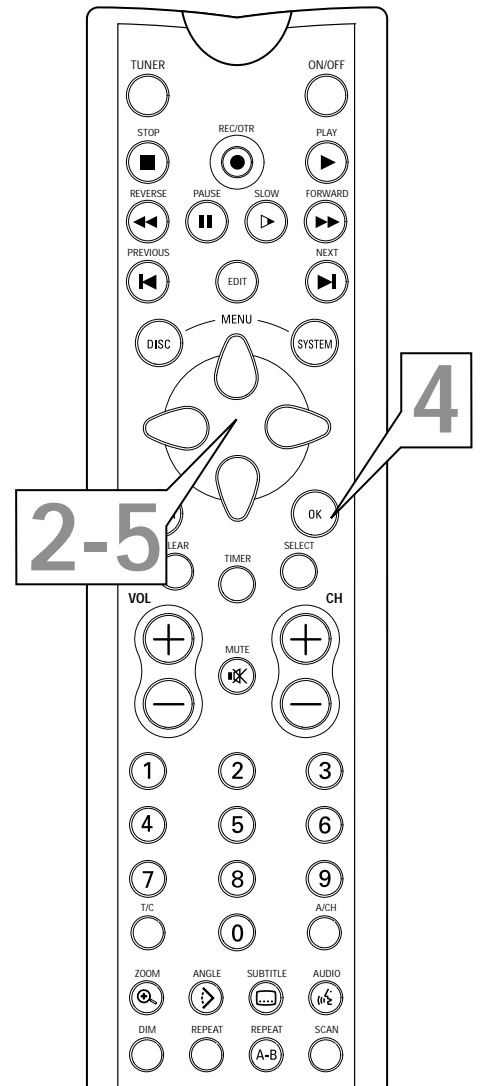

5 Press **◀** to return to the Index Picture Screen if necessary.

Manual Recording Volume, Append Recording 45

Manual Recording Volume

You can adjust manually the volume level of your DVD Recorder during recording.

- 1** During recording of a TV broadcast, press **AUTO/MAN REC VOLUME** on the front of the DVD Recorder. (You may have to press **PANEL** first to access the front panel buttons.) The display will show the current audio level. **MANUAL** appears on the display.
- 2** Press **MANUAL ▲▼** on the front of the DVD Recorder to adjust the volume level.
- 3** To return to automatic audio level control, press **AUTO/MAN REC VOLUME** again. **MANUAL** will disappear from the display.

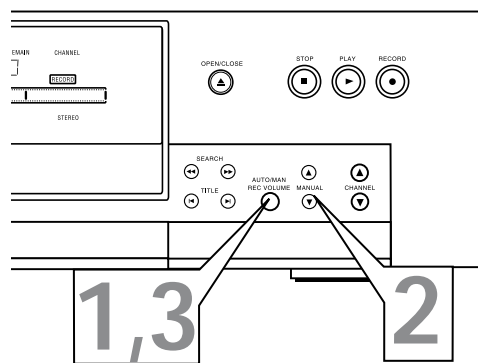

Append recording

To add a new video recording to an earlier recorded Title, follow these steps.

- 1** In the Index Picture Screen, press **▲▼** to select the Title to which you want to add a recording.
- 2** Press **PLAY ►**.
- 3** When you reach the point at which you want to start the new recording, press **PAUSE ■■**.
- 4** Press **TUNER**, then press **CH+/-** to select the channel (or other equipment) you want to record.
- 5** Press **REC/OTR**. The new recording will start at the point you selected and overwrite the video material beyond this point, including later Titles.
- 6** Press **STOP ■** to stop recording.

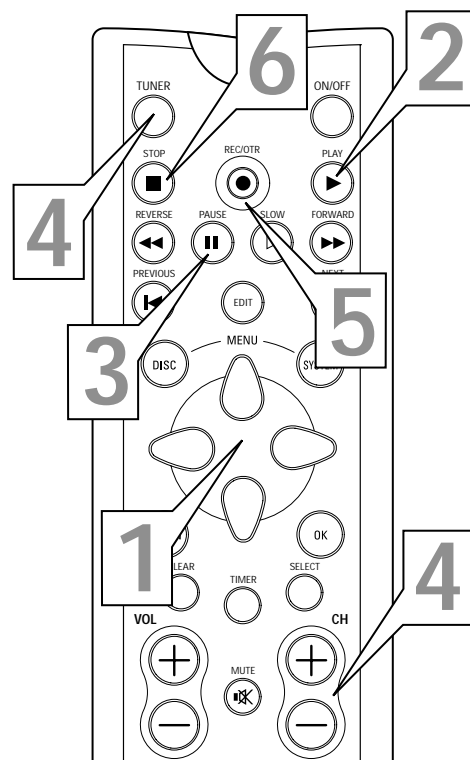

Helpful Hint

- You can not use Manual Audio Control when recording from equipment that is connected to the DV jack on the front of the Recorder. Manual Audio Control is only effective when recording in Tuner mode.

46 Record Settings, Chapter Markers

Record Settings

1 Press **SYSTEM MENU**. may be selected. If it is not, press **◀** to select it.

2 Press **▼** repeatedly to select , then press **▶**.

3 Press **▲▼** to select **Record mode**, **Auto chapters**, or **LP/EP rec mode**, then proceed as described in step 4.

4 ● **Record mode**

Press **◀▶** to choose **SP**, **LP**, **EP**, or **HQ**, then press **OK**. "Stored" will appear briefly. Now, recordings will be made in the speed, or mode, you selected.

The recording mode defines the picture quality of recordings and the maximum recording time for a Disc. You can play a Disc only in the mode in which it was recorded. See the chart below for details.

● **Auto chapters**

Press **◀▶** to choose **On** or **Off**, then press **OK**. "Stored" will appear briefly. If Auto chapters is On, the Recorder will insert a Chapter marker automatically every five to six minutes during recording. To disable this feature, select Off.

You can manually insert Chapter markers after recording. *Details are on page 48.* You also may insert Chapter markers manually during recording. See Chapter Markers below.

● **LP/EP rec mode (recording mode)**

Press **◀▶** to choose **Stndrd (Standard)** or **Sport**, then press **OK**. "Stored" will appear briefly. Adjust this setting only if you chose LP or EP at Record mode as described above. (The setting has no effect when recording in HQ or SP.) When recording in LP or EP speed, select Sport to improve recording of images that move quickly. Otherwise, choose Stndrd.

5 Press **SYSTEM MENU** repeatedly to remove the menus.

Mode	Picture quality	Recording time per Disc
HQ (High Quality)	Highest quality; allows least recording time per Disc	60 minutes
SP (Standard Play)	Equals quality of a pre-recorded DVD	120 minutes
LP (Long Play)	Equals quality of an S-VHS tape	180 minutes
EP (Extended Play)	Exceeds VHS tape quality; allows most recording time per Disc	240 minutes

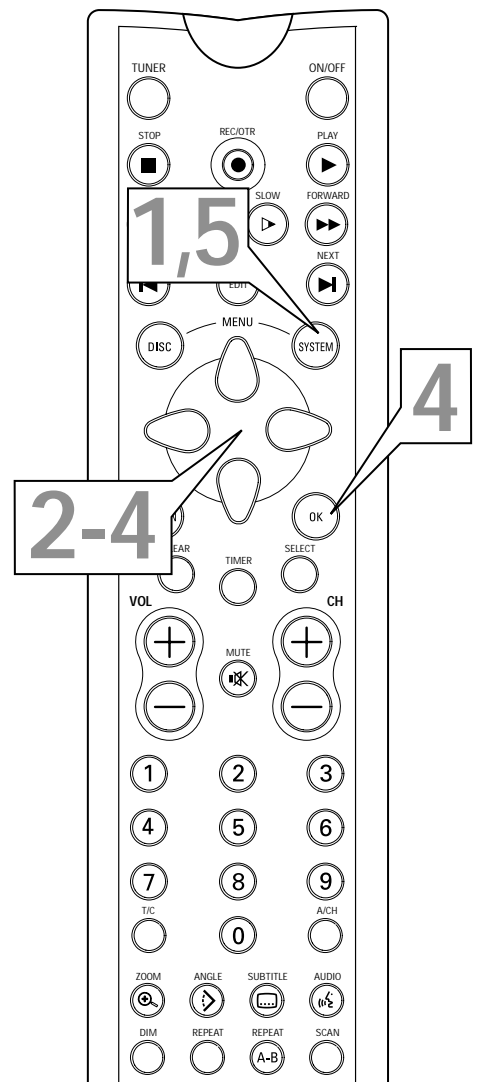

Chapter Markers

Chapter Markers let you move easily through recordings by pressing **NEXT ▶** or **PREVIOUS ◀** to select the next marker during playback. This allows you to access specific points on a DVD+RW much as you would choose a specific Chapter for playback on a DVD.

1 Press **EDIT** during recording to insert a Chapter marker at the current position. "Inserting chapter marker" will appear briefly. The maximum number of markers varies per Disc. When the maximum number is reached, "Too many chapters" will appear. Delete some Chapter markers before inserting more. *Details are on page 48.*

Helpful Hint

- Use HQ when recording from digital sources, such as a digital camcorder.

Editing: Disc Information Screen 47

You can change Disc settings for a DVD+RW from the Disc Information Screen.

- 1 When in the Index Picture Screen, press **STOP** ■ to select the first Title on the DVD+RW.
- 2 Press **▲** to enter the Disc Information Screen.
- 3 In the Disc Information Screen, press **▶** to enter the Settings menu.

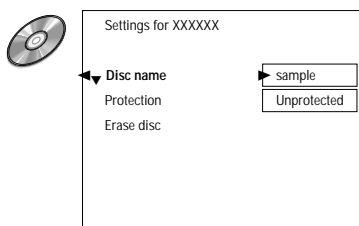

- 4 Press **▲▼** to select Disc name, Protection, Erase Disc, or Make edits compatible. Proceed as follows, depending on which feature you want to adjust.
 - **Disc name**
Press **▶**. Press **◀▶** to choose the character position, then press **▲▼** to enter a character. Press **SELECT** to alternate between capital and lower case characters. Press **CLEAR** to erase a character (the space will remain). A name may contain a maximum of 64 characters.
To return to the Settings menu, press ◀, repeatedly if necessary. "Storing name" will appear briefly.
 - **Protection**
Press **▶**. Press **▲▼** to select Protected or Unprotected, then press **OK**. If you protect the Disc, you can not make any further changes to the Disc, including recording. "Disc locked" will appear on the TV screen briefly if you attempt recording. Choosing Protected also disables most editing features.
To edit or record again, select Unprotected.
 - **Erase disc**
Press **OK**. "This will erase all titles Press OK to confirm" will appear. Press **OK** again to begin erasing. (If you decide not to erase the Disc, press **◀**.) "Erasing disc" appears until erasing is complete. When the Disc is erased, the Index Picture Screen will reappear, showing the free space on the Disc.
 - **Make edits compatible**
This option appears only if the current DVD+RW is not compatible with other DVD Players. **After choosing Make edits compatible, press OK.** "This will take XX" and "Press OK to confirm" will appear to indicate how long the action will take.
Press OK again. "Working .." and a progress bar will appear until the action is complete.

- 5 Press **◀** when you are finished and want to return to the Disc Information Screen.

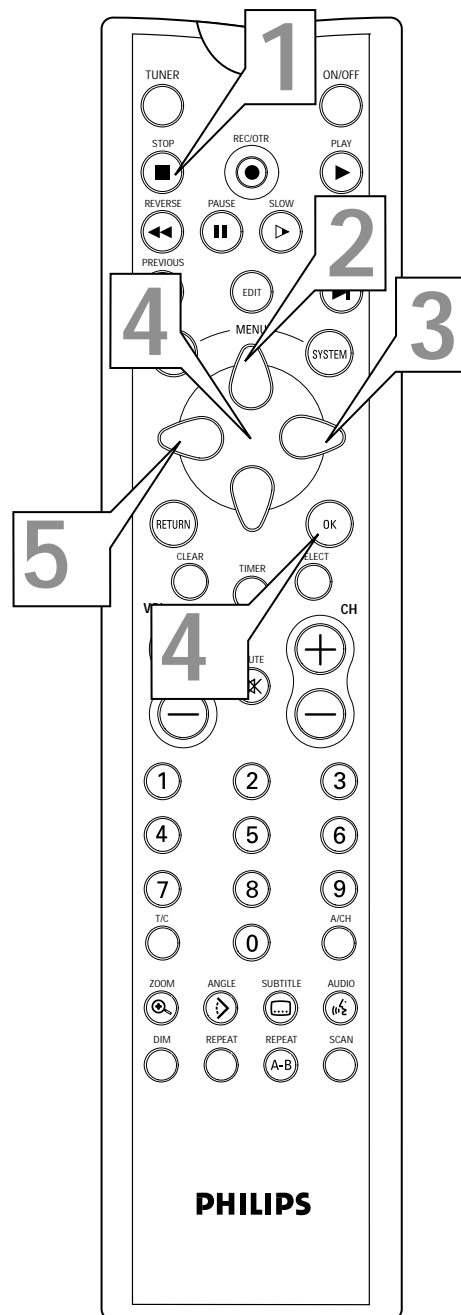

PHILIPS

Helpful Hint

- For information on the Index Picture Screen, see page 35.

48 Editing

1 On the Index Picture Screen, press ▲▼ to select the Title you want to edit, then press PLAY ► to begin playback.

2 During DVD+RW playback, press EDIT. The Favorite Scene Selection menu will overlay the currently playing video image. The current Title and Chapter numbers will appear at the top of the screen.

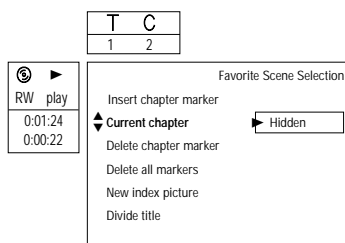

3 Press ▲▼ to select Insert chapter marker, Current chapter, Delete chapter marker, Delete all markers, New Index Picture, or Divide title, then proceed as described in step 4.

4 ● If you select Insert chapter marker, press OK. "Inserting chapter marker" will appear briefly. This places a Chapter marker at the point you select. Then, you can move quickly to that point during playback by pressing NEXT ► or PREVIOUS ◀ to select the next Chapter.

● If you select Current chapter, press ► (or SELECT) repeatedly to select Visible or Hidden, then press OK. Initially all Chapters are visible during playback. By hiding chapters or making them visible, you determine which chapters you want to view. For example, if you do not want to watch certain scenes (for example, commercials), hide that segment by choosing Hidden. Then, watch your recording without the hidden chapters. The picture may freeze briefly between scenes, but you will not see the hidden content.

● If you select Delete chapter marker, press OK. This deletes the Chapter marker at the beginning of the current Chapter. (This option is not always available.)

● If you select Delete all markers, press OK. "This will delete all markers in this title. Press OK to confirm" will appear. Press OK again. (If you decide not to delete all markers, press ◀.) (This option is not always available.)

● If you select New Index Picture, press PAUSE || or SLOW ► to accurately choose a frame of picture during playback. This frame will become the miniature picture that will appear in the Index Picture Screen for the current Title. When you reach the desired picture frame, press OK. "This will update the index picture Press OK to confirm" will appear. Press OK again. "Updating menu" will appear, then the Index Picture Screen will reappear when the action is complete. (If you decide not to select a new Index Picture, press ◀.)

● If you select Divide title, press PAUSE || to accurately choose the point at which you want to start the new Title. Press OK. "This will divide this title into two separate titles. Press OK to confirm" will appear. Press OK again. "Dividing title" appears until the action is completed. The Index Picture Screen will reappear. (If you decide not to divide the Title, press ◀.)

5 Press EDIT to remove the Favorite Scene Selection menu if necessary.

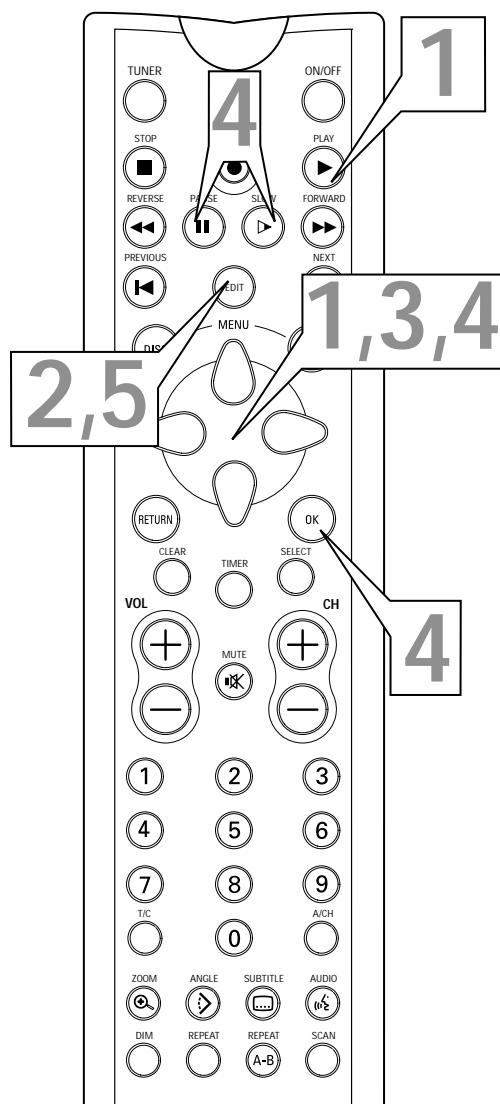



Helpful Hints

- The maximum number of Chapters per Title varies. When you reach the maximum number, "Too many chapters" will appear on the screen. Delete Chapters before making more.
- The Favorite Scene Selection menu will disappear after about five minutes if you do not edit any information.
- You cannot undo a Title division. A new index picture will appear at the point at which you divided the Title. The Index Picture Screen will show two titles instead of one, but both will have the same name. You can change the name in the Title Settings menu. Details are on page 44.

DVD VIDEO CD

Access Control limits viewing of Discs that exceed the limits you set. This feature will not limit viewing if the Disc manufacturer did not code the Disc. Philips cannot guarantee the availability of Access Control with all Discs, and therefore denies any liability associated with unintended watching of Discs. Make sure your Discs play according to your Access Control settings before you allow children access to the DVD Recorder.

Change Code

- 1 Press **SYSTEM MENU**.  may be selected. If it is not, press **◀** to select it.
- 2 Press **▼** repeatedly to select , then press **▶**. Access control will be selected.
- 3 Press **▶** again, then press the **Number buttons** to enter your **old four-digit code**. When doing this the first time, enter any four numbers you prefer. You will have to enter the same code, exactly, twice. This will set your code for the first time.

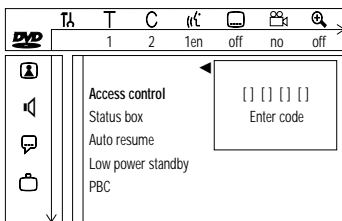

- 4 Press **▼** repeatedly to select **Change code**, then press **▶**.

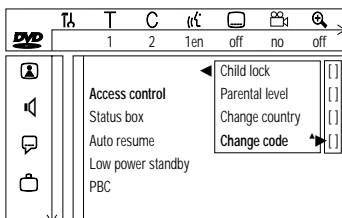

- 5 Press four **Number buttons** to enter the new four-digit code. Then, enter it again - exactly - to confirm it.

- 6 Press **SYSTEM MENU** to remove the menu.

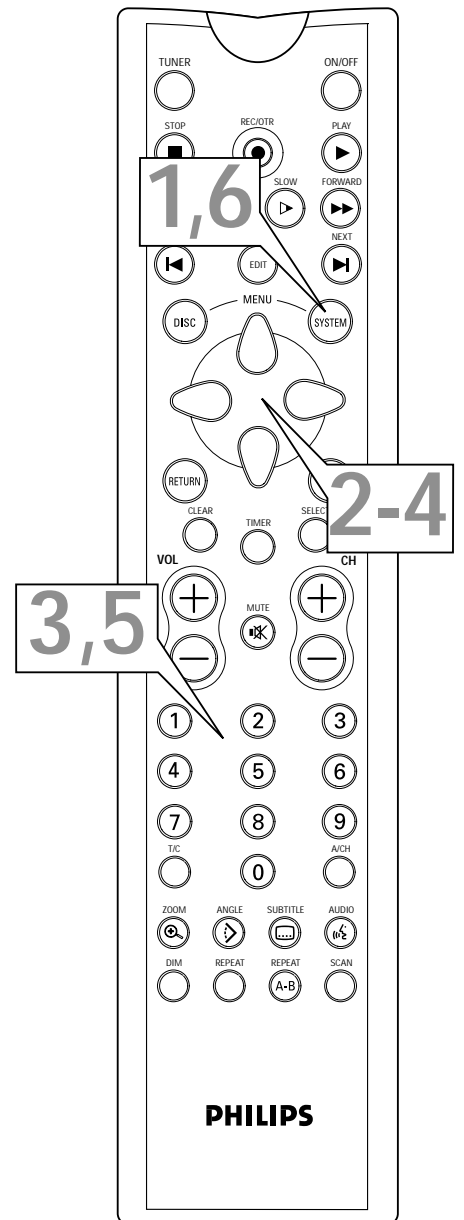



Helpful Hint



- The code may not go into effect until you activate Child Lock. (You may have to keep confirming the code.) See page 50 to activate Child Lock.

50 Access Control (cont'd)

Child Lock

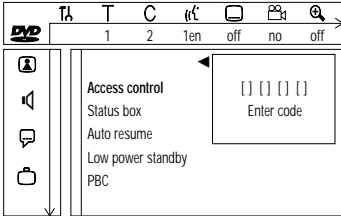
- 1 Press **SYSTEM MENU**.  may be selected. If it is not, press **◀** to select it.
- 2 Press **▼** repeatedly to select , then press **▶**. Access control will be highlighted.
- 3 Press **▶** again, then press the **Number** buttons to enter your four-digit code. *Details are on page 49.*



- 4 Child lock will be highlighted. Press **▶**.
- 5 Press **▲▼** to select **Locked**  or **Unlocked** , then press **OK**. If you chose Locked, unauthorized or Locked Discs will not play unless you enter your four-digit code.

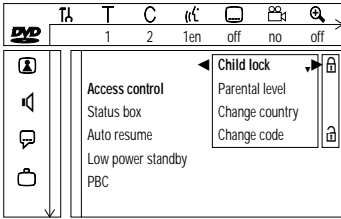

- 6 Press **SYSTEM MENU** to remove the menus.

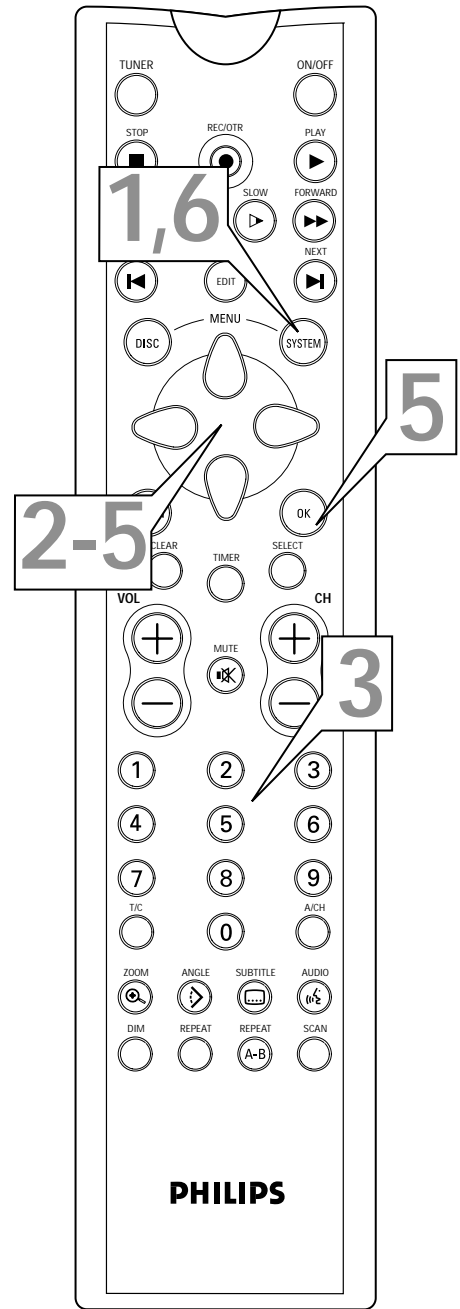

Locking or Unlocking Specific Discs

Not all DVDs are rated or coded by Parental levels. You may choose to specifically lock or unlock a Disc by choosing Play once or Play always. This way, you can disable viewing regardless of the rating of the DVD. You will need to know your 4-digit code in order to view the Disc.

- 1 Insert a Disc.** The Access Control message will appear on the TV screen. (Child Lock should be Locked. *Details are on page 50.*)



- 2 Press ▲▼ to select Play once or Play always. Then, press the Number buttons to enter your four-digit code.** If you select Play Once, the Disc can play as long as it is in the DVD Recorder and the DVD Recorder power is On. If you select Play Always, the Disc will play, even if you set Child Lock to (Locked). *Details are on page 50.*

- 3 If you later decide to lock the Disc so that it will not play always:** When you insert the Disc, playback begins automatically and safe appears on the TV screen. **Press STOP ■ while safe is on the TV screen.** Locked will appear. If the Disc continues playing, press STOP ■ again to stop playback. You may need to turn off the DVD Recorder or remove the Disc before the Disc is completely Locked. The next time you turn on the DVD Recorder, the Disc will not play unless you enter the four-digit code.

- 1 Insert a Disc.**

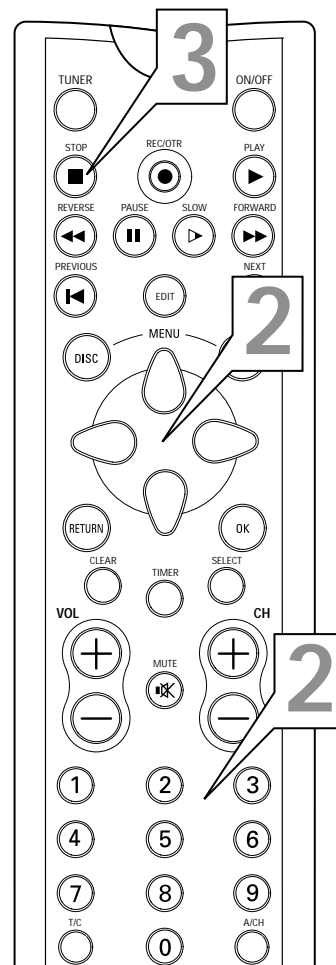



Helpful Hints

- The Access Control screen will appear when you try to play a Locked Disc. If you do not know your code, press STOP ■. Then, select Access Control as described in steps 1-3 on page 49. When you are asked to enter the code, press STOP ■ four times. Press SYSTEM MENU, then press PLAY ► to start playback. This restores all the Access Control settings to their original factory settings.
- Two-sided DVDs may have a different ID for each side. To unlock the entire Disc, unlock each side.
- Multi-volume Video CDs may have a different ID for each volume. To unlock the complete set, unlock each volume.

52 Access Control (cont'd)

Parental Level

DVDs may contain alternative scenes that conform to the Parental Level, or movie rating, that you select. The Parental Level may apply to the complete Disc or to certain scenes on the Disc. These scenes are rated from 1 to 8. Follow the steps below to set the Parental Level at which you want Discs to play.

- 1 Press **SYSTEM MENU**.  may be selected. If it is not, press **◀** to select it.
- 2 Press **▼** repeatedly to select , then press **▶**. Access control will be highlighted.
- 3 Press **▶** again, then press the **Number** buttons to enter your four-digit code.

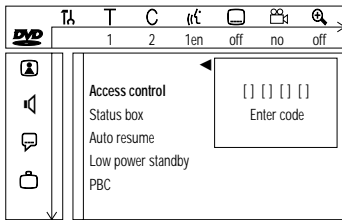

- 4 Press **▼** to select Parental level, then press **▶**.
- 5 Press **▲▼** or the **Number** buttons to select a rating, then press **OK**.
Select "0" (–) to deactivate Parental level. The entire Disc will play.
Choose a rating between 1-8, and scenes with the same rating or lower will play. Higher rated scenes will not play unless an alternative scene is available on the Disc. The alternative must have the same rating or a lower one. If no suitable alternative is found, playback will stop. Enter the 4-digit code to play the Disc.

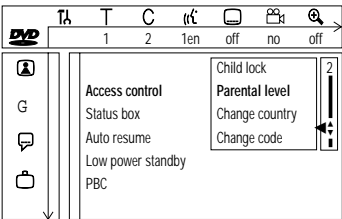

- 6 Press **SYSTEM MENU** to remove the menus.

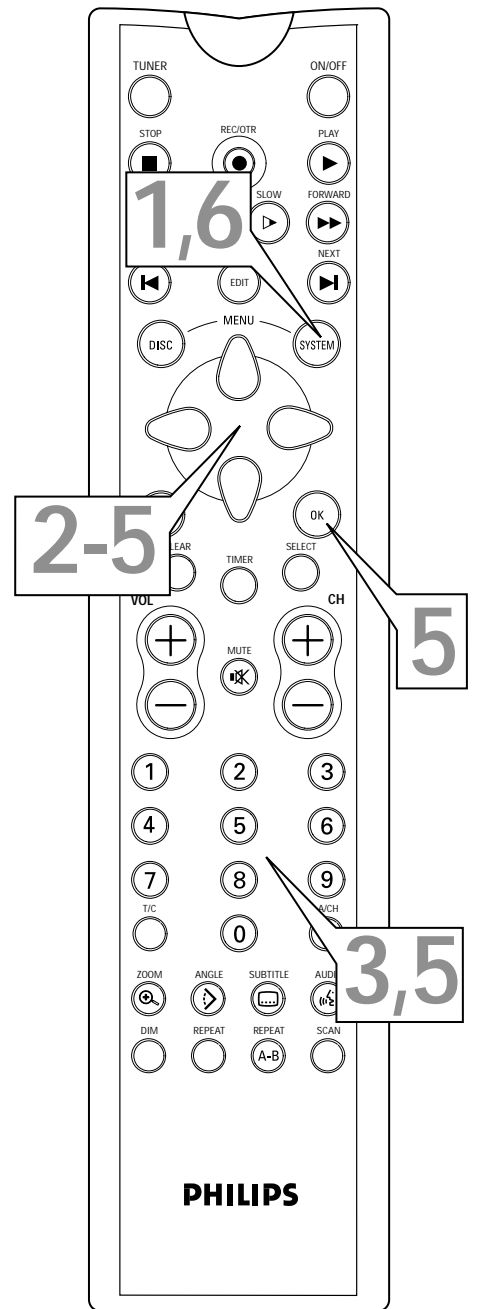



Helpful Hint

- The rating numbers compare to standard U.S. movie ratings as follows:
 - 7 - NC-17
 - 6 - R
 - 4 - PG-13
 - 3 - PG
 - 1 - G

Change Country

If a Disc has Parental Level coding, the codings are applicable only for the country specified on the Disc. The Disc manufacturer sets these codings. For example, a Disc may be coded at Level 3 for the United States. So, for some Discs, you may need to choose the Country for which the Disc is coded in order for the Disc to play at the Parental Level you select. *Details are on page 52.* Also refer to your Disc case for more information.

- 1 Press **SYSTEM MENU**.  may be selected. If it is not, press **◀** to select it.
- 2 Press **▼** repeatedly to select , then press **▶**. Access control will be highlighted.
- 3 Press **▶** again, then press the Number buttons to enter your four-digit code. Child lock will be highlighted.
- 4 Press **▼** repeatedly to select Change country, then press **▶**.

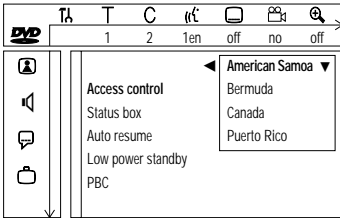

- 5 Press **▲▼** to select the country for which the Disc is coded, then press **OK**.
- 6 Press **SYSTEM MENU** to remove the menus.

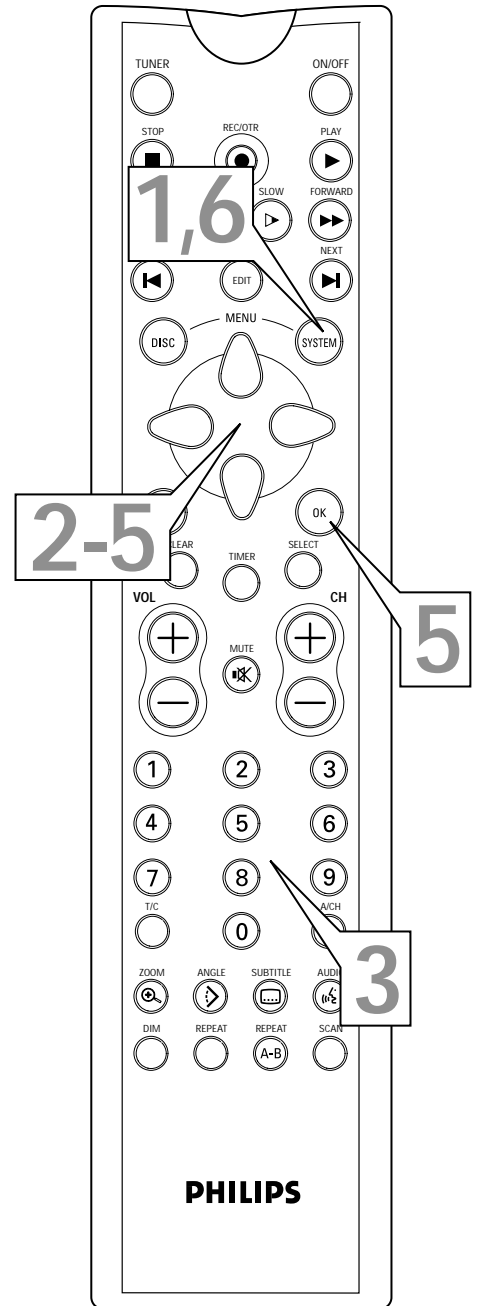

54 User Preference Settings

- 1 Press **SYSTEM MENU**. may be selected. If it is not, press to select it.
- 2 Press repeatedly to select , then press .
- 3 Press to select **Status box**, **Auto resume**, **Low power standby**, or **PBC**. Then, press and follow step 4 according to your choice.

4 ● If you selected **Status box**, press to choose **On** or **Off**, then press **OK**. The status box displays the current Disc type and status of the Recorder. Select **On** if you want to see the Status box with the Menu Bar or briefly when you change playing or recording status. Choose **Off** if you do not want to see the Status boxes.

● If you selected **Auto resume**, press to choose **On** or **Off**, then press **OK**. Auto resume affects the last 20 pre-recorded DVDs and Video CDs you played. When Auto resume is **On**, play resumes at the point at which it stopped the last time you played the Disc. If Auto resume is **Off**, the Recorder starts playing the Disc from the beginning of the Disc.

● If you selected **Low power standby**, press to choose **On** or **Off**, then press **OK**. If Low power standby is **On** and you do not use the Recorder for 20 minutes, the image on the TV screen will dim.

● If you selected **PBC (Playback Control)**, press to choose **On** or **Off**, then press **OK**. Playback Control is a feature available on some Video CDs that allows you to choose playing features from those available on the Disc. The Video CD must be compatible with Playback Control. Check the Video CD case for details. The Video CD will show instructions or options on the TV screen. Use the DVD Recorder's remote control buttons as directed by the Video CD. Set PBC to **On** only if you are playing PBC-compatible Video CDs on the DVD Recorder. Otherwise, set PBC to **Off**.

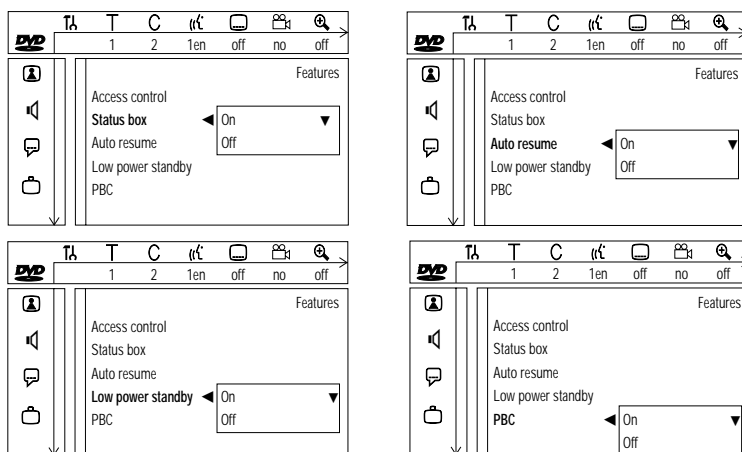
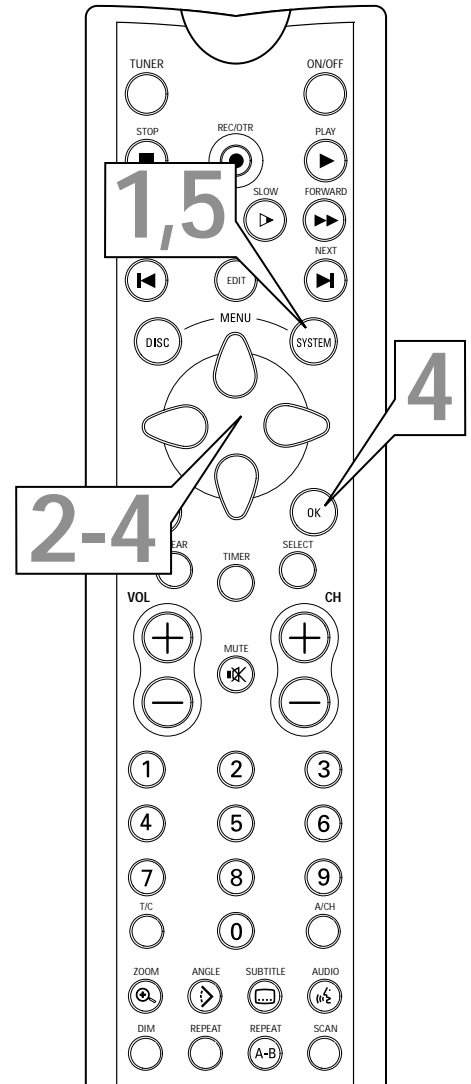

- 5 Press **SYSTEM MENU** repeatedly to remove the menus.

Helpful Hints

- *Adapt Disc Format will appear if a DVD+RW recorded on a different brand of Recorder is in the Philips Recorder. The option only appears when such a Disc is in the Philips Recorder. If the Disc is unprotected, you can adapt the disc format by selecting Adapt Disc Format. This will enable you to play the Disc and access its features, such as the menus or edited versions.*
- *If resume appears when you start playback, you can press PLAY while resume appears on the TV screen. This lets you resume play from the last played point, even if Auto resume is Off.*

1 Press **SYSTEM MENU**. may be selected. If it is not, press **◀** to select it.

2 Press **▼** to select , then press **▶**.

3 Press **▲▼** to select **TV Shape**, **Black level shift**, or **Video shift**. Then, press **▶** and follow step 4 according to your choice.

4 ● If you selected **TV Shape**, press **▲▼** to select **4:3 letterbox**, **4:3 panscan**, or **16:9**, then press **OK**.
 Select 4:3 letterbox if you have a regular TV and want to see the picture with black bars at the top and bottom of the screen. This looks like the picture you see when watching movies in a theater. This setting is possible only if the DVD contains letterbox material.
 Select 4:3 panscan if you have a regular TV and want both sides of the picture to be trimmed, or formatted to fit your TV screen. This setting is possible only if the DVD contains pan & scan material.
 Select 16:9 if you have a widescreen TV.

● If you selected **Black level shift**, press **▲▼** to select **On** or **Off**, then press **OK**. Set Black level shift to **On** during playback of NTSC Discs. This will improve the color contrast during Disc playback. Black level shift has no effect on PAL Disc playback.

● If you selected **Video shift**, press **◀▶** to center the picture on your TV screen - or "shift" the video. When you are satisfied with the position of the picture, press **OK**.

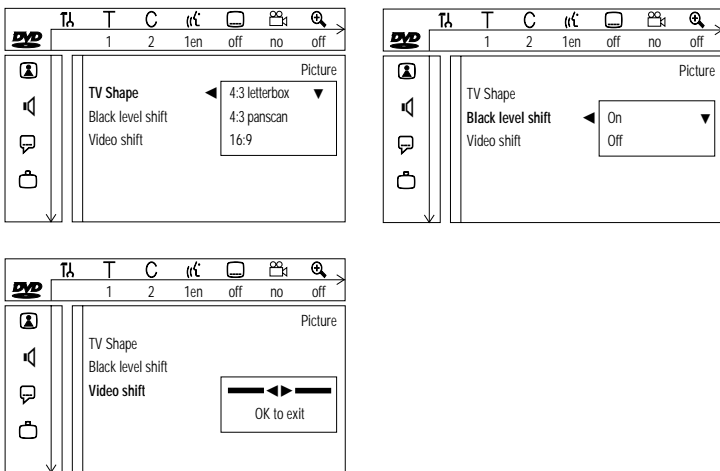

5 Press **SYSTEM MENU** to remove the menus.

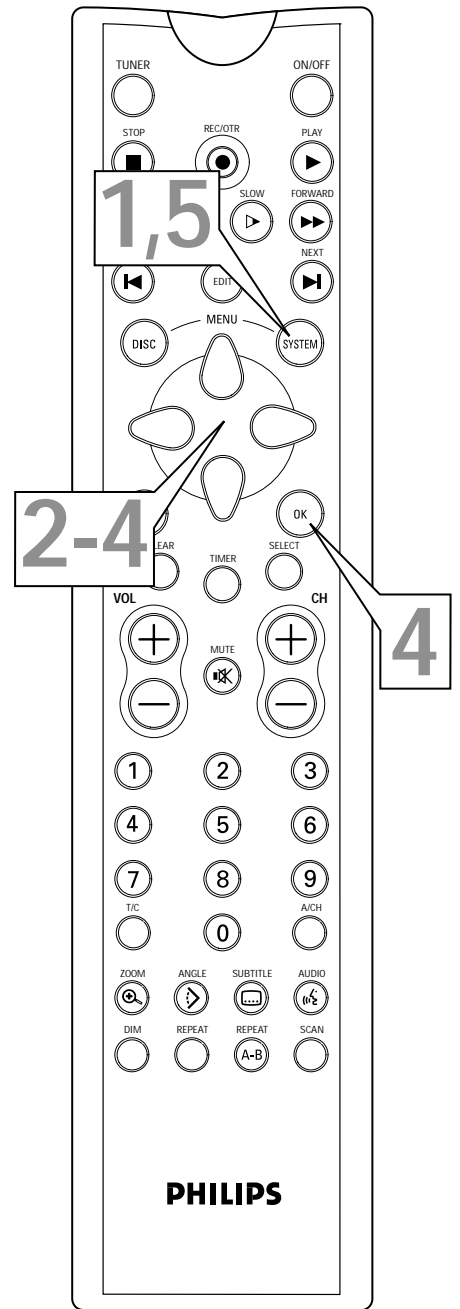

Helpful Hints

- The format you select must be available on the Disc. If it is not, the settings for TV Shape will not affect the picture during playback.
- Some widescreen TVs may show only part of the DVD Recorder's menu. Adjust the screen mode on your TV. See your TV owner's manual for details.

56 Digital Output

After connecting the DVD Recorder to your TV and other equipment, you may need to change the DVD Recorder's Digital Output setting. Look to see which DVD Recorder audio jacks you connected to your other equipment, then set your Digital Output accordingly. The information in step 4 will help you make your choice.

You only need to adjust the Digital Output if you used the DIGITAL AUDIO OUT (OPTICAL or COAX) jacks of the Recorder. (If you used the red and white AUDIO OUT jacks, see page 57 to adjust the sound.)

- 1** Press **SYSTEM MENU**. may be selected. If it is not, press **◀** to select it.
- 2** Press **▼** repeatedly to select , then press **▶**.
- 3** Digital output will be selected. Press **▶**. If Digital output is not selected, press **▲▼** to select it.
- 4** Press **▲▼** to select **Off**, **PCM only**, or **All**, then press **OK**.
 - Select **All** if you used the **COAX** (coaxial) **DIGITAL AUDIO OUT** jack to connect the DVD Recorder to a Stereo Receiver that has a built-in Multi-channel Decoder. *Details are on page 14.*
 - Select **Off** if you did not use either the **COAX** (coaxial) or **OPTICAL DIGITAL AUDIO OUT** jack. For example, if you used the supplied audio cables to connect the red and white **AUDIO OUT** jacks of the DVD Recorder to a TV or Stereo, select **Off**. See page 57 to adjust your analog sound settings.
 - Select **PCM only** if you used the **COAX** (coaxial) or **OPTICAL DIGITAL AUDIO OUT** jacks of the DVD Recorder for connections, but the audio equipment does not include a built-in digital multi-channel Decoder.

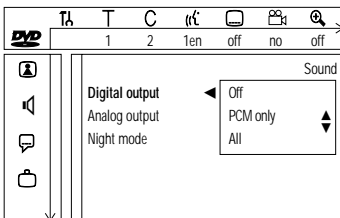

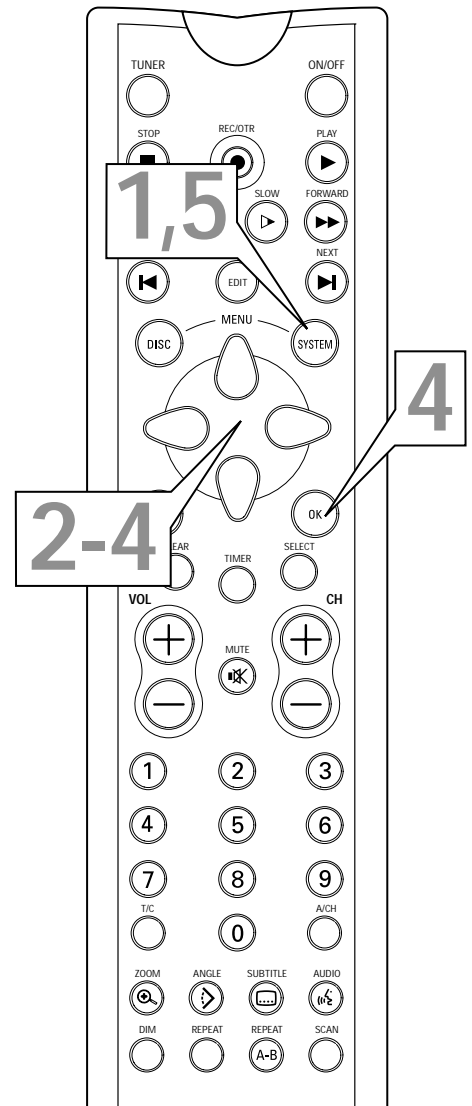

- 5** Press **SYSTEM MENU** to remove the menus.



If you connected the DVD Recorder's red and white AUDIO OUT jacks to a Stereo (or Stereo TV) as shown on pages 10-13, choose a setting for Analog Output.

You do not need to adjust this setting if you used the DIGITAL AUDIO OUT (OPTICAL or COAX) jacks on the DVD Recorder.

Check your Stereo and see if it is compatible with Dolby Surround or TruSurround. Then follow the steps below to choose the Analog Output setting that is most compatible with your audio equipment (or TV).

- 1** Press **SYSTEM MENU**.  may be selected. If it is not, press **◀** to select it.
- 2** Press **▼** repeatedly to select , then press **▶**.
- 3** Press **▼** to select **Analog output**, then press **▶**. Analog output may be selected already. If so, just press **▶** to continue.
- 4** Press **▲** or **▼** to select **Stereo**, **Surround**, or **3D sound**, then press **OK**.
 - Select Stereo if your audio equipment is not compatible with either Dolby Surround or TruSurround, or if you connected the DVD Recorder to a Stereo TV only.
 - Select Dolby Surround compatible if your audio equipment is compatible with Dolby Surround. If it is, usually a Dolby Pro Logic logo will appear on the equipment.
 - Select 3D if the audio equipment is TruSurround compatible. Again, the audio equipment likely will be labeled with the TruSurround logo as shown below.

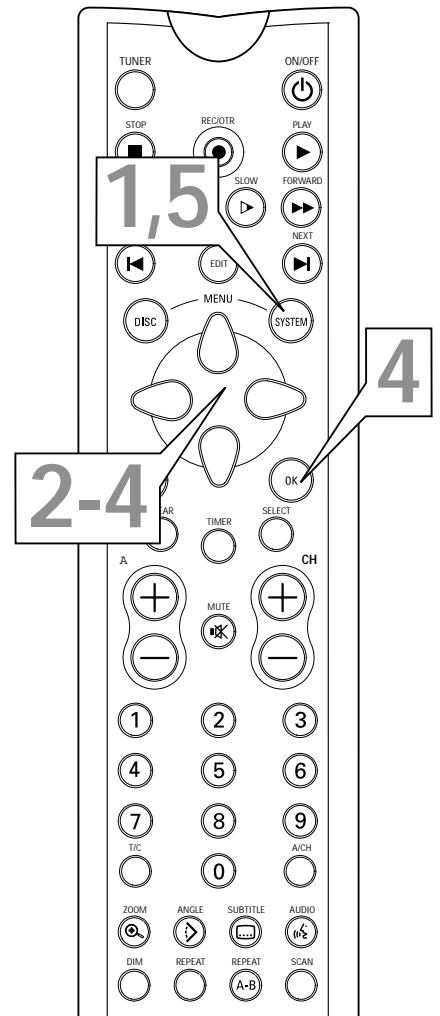
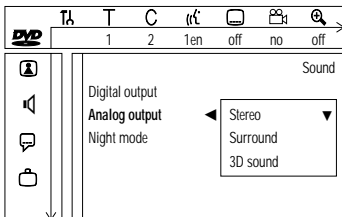

- 5** Press **SYSTEM MENU** to remove the menus.

TruSurround™
by **SRS (●)®**

TruSurround and the  symbol are trademarks of SRS Labs, Inc. TruSurround technology is incorporated under license from SRS Labs, Inc.

Helpful Hint

- You also can set analog sound in the Menu Bar. Details are on page 31.

58 Language Settings, Recording Audio

DVD

Language Settings

Select a different language for the Disc Menu, Audio soundtrack, or Subtitles if multiple languages are available on the Disc.

- 1 Press **SYSTEM MENU**. may be selected. If it is not, press **◀** to select it.
- 2 Press **▼** repeatedly to select , then press **▶**.
- 3 Press **▲▼** to select **Playback Audio**, **Subtitle**, or **Menu**, then press **▶**.
- 4 Press **▲▼** to select the language you want, then press **OK**. The changes will be effective only if the language is available on the Disc. Some DVDs allow you to change languages in the DVD Disc Menu only.
- 5 Press **SYSTEM MENU** to remove the menus.

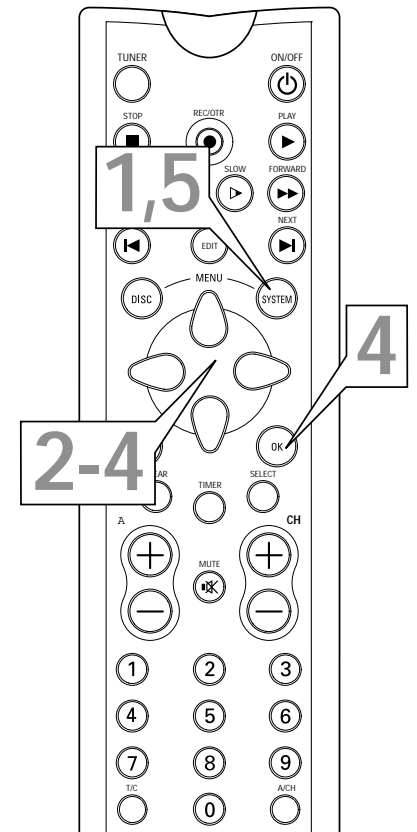
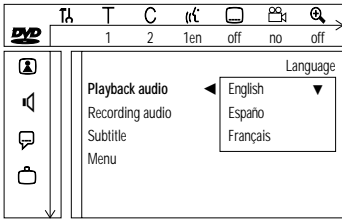

DVD+RW

Recording Audio

Some TV programs broadcast in stereo or in a second audio program (SAP). Usually, second audio means the program has a second language available. For example, the program might be available in English and Spanish, with Spanish being the SAP (second audio program) option.

To record the stereo or SAP broadcasts with the DVD Recorder, select Stereo or SAP as your preferred recording audio as described below. Your selection will only be active if the program is available in stereo or second audio. When you play the recording, you can play only in the audio you recorded. For example, if you recorded in SAP, you can play the recording only in SAP.

- 1 Press **SYSTEM MENU**. may be selected. If it is not, press **◀** to select it.
- 2 Press **▼** repeatedly to select , then press **▶**.
- 3 Press **▲▼** to select **Recording Audio**, then press **▶**.
- 4 Press **▲▼** to select **Stereo** or **SAP**, then press **OK**.
- 5 Press **SYSTEM MENU** to remove the menus.

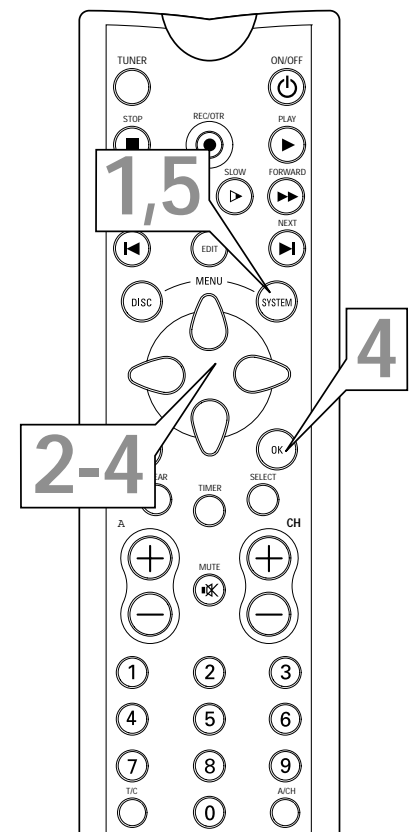
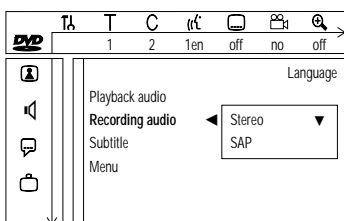

Night Mode

Turn on Night Mode to improve the sound during low volume playback.

- 1 Press **SYSTEM MENU**. may be selected. If it is not, press **◀** to select it.
- 2 Press **▼** repeatedly to select , then press **▶**.
- 3 Press **▼** repeatedly to select **Night mode**, then press **▶**.

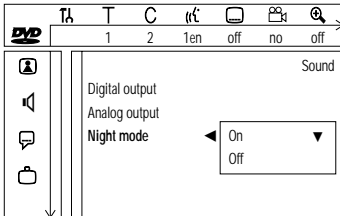

- 4 Press **▲** or **▼** to select **On** or **Off**, then press **OK**.
- 5 Press **SYSTEM MENU** to remove the menus.

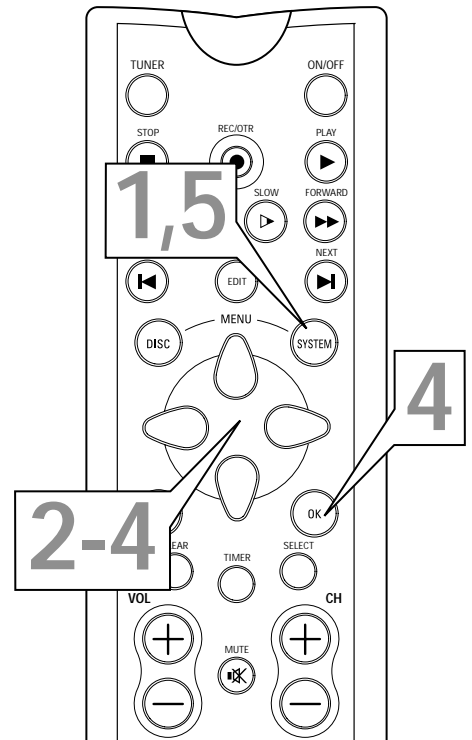

Remote Control Settings

- 1 Press **SYSTEM MENU**. may be selected. If it is not, press **◀** to select it.
- 2 Press **▼** repeatedly to select , then press **▶**.
- 3 Press **▲▼** to select **Key sound** or **Remote control used**. Then, press **▶** and follow step 4 according to your choice.
- 4
 - If you selected **Key sound**, press **▲▼** to select **On** or **Off**, then press **OK**.

Select **On** if you want the DVD Recorder to beep each time you press a key on the remote control or the Recorder. The factory setting is **On**. Select **Off** to disable the sound; the Recorder will be silent when you press buttons on the remote or the Recorder.

- If you selected **Remote control used**, press **▲▼** to select **DVD Player** or **DVD Recorder**, then press **OK**. The factory setting is **DVD Recorder**. By selecting **DVD Recorder**, you will operate the DVD Recorder with the remote control supplied with the DVD Recorder (as shown at right and throughout this book). However, if you have another Philips DVD Player and want to use that remote to also control the DVD Recorder, you may do so if you select **DVD Player** as the Remote Control used.

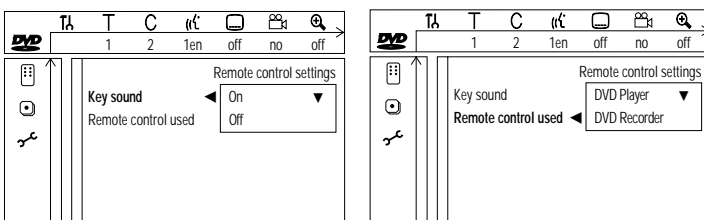

- 5 Press **SYSTEM MENU** repeatedly to remove the menus.

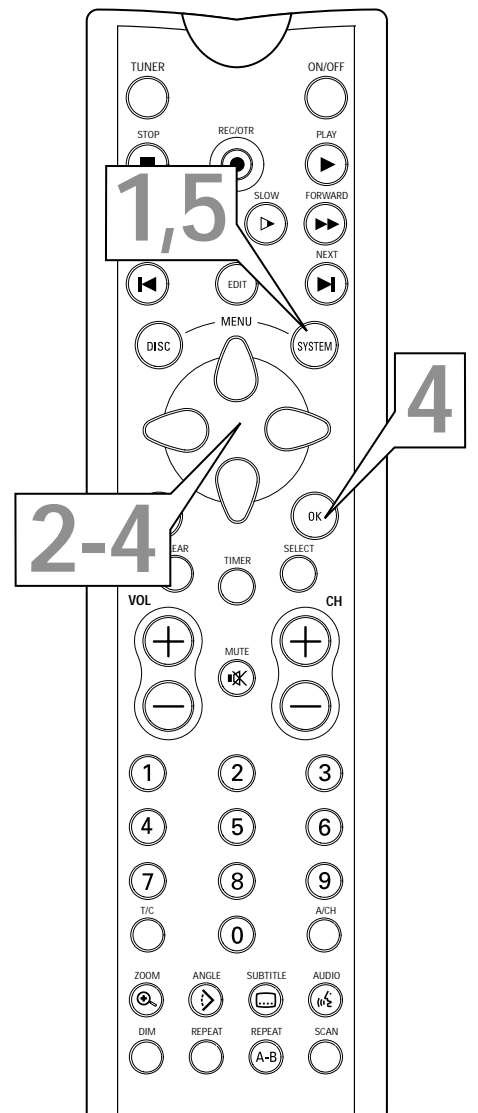

60 Using Your Recorder's Remote Control with Your TV

The following buttons on your DVD Recorder's remote control will operate the TV at any time:

- **VOL +/-** increases/decreases TV volume
- **MUTE** mutes/activates the TV sound

The following buttons operate the TV if you press and hold the TV switch on the right side of the remote while pressing these buttons:

- **CH +/-** Selects TV channels at the TV (not the Recorder)
- **A/CH** Selects the TV channel you were viewing just before switching to the current channel.
- **Number buttons 0-9** Press to choose a TV channel quickly.
- **Power button** Press to turn on or off the TV power.

If these buttons already operate your TV, no further action is necessary. If they do not, follow these steps for either Automatic Remote Setup or Manual Remote Setup to make the Recorder's remote control operate your TV.

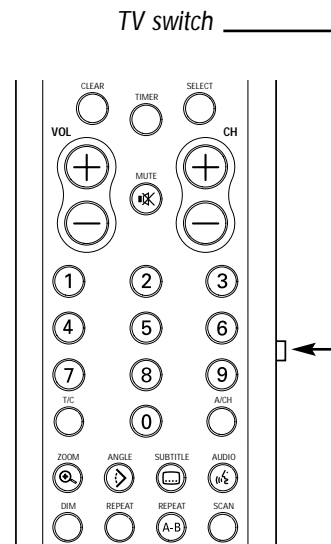

Automatic Remote Setup

- 1 Turn on your television and find the code for your brand of TV in the list on page 61.
- 2 Point the remote control at the TV. Press and hold the RETURN and SELECT buttons simultaneously for at least three seconds, then release.
- 3 Within 30 seconds, press the Number buttons to enter the correct three-digit code for your brand of TV.
- 4 See if the remote control now works your TV as described above. If it does, you are finished. If it does not, repeat steps 1-3, using a different code for your brand, if available. If the remote still will not operate your TV after repeating steps 1-3 with all the codes for your brand, try the Manual Remote Setup procedure as described below.

Automatic Remote Setup

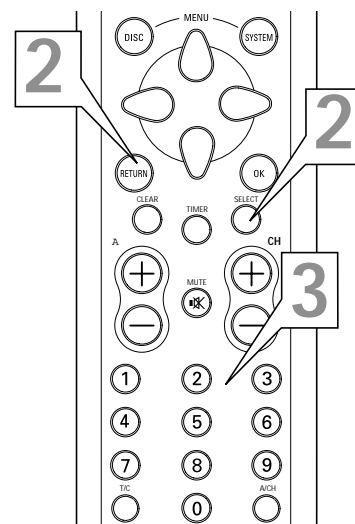

Manual Remote Setup

- 1 Turn on your television.
- 2 Point the remote control at the TV. Press and hold the RETURN and SELECT buttons simultaneously for at least three seconds, then release.
- 3 Within 30 seconds, press and hold the ON/OFF button until your TV turns off. Your TV will turn off when the remote control finds the correct code that will allow the remote to work your TV. When your TV turns off, immediately release the ON/OFF button. This step may take up to two minutes.
- 4 Make sure your remote works your TV as described above.

Manual Remote Setup

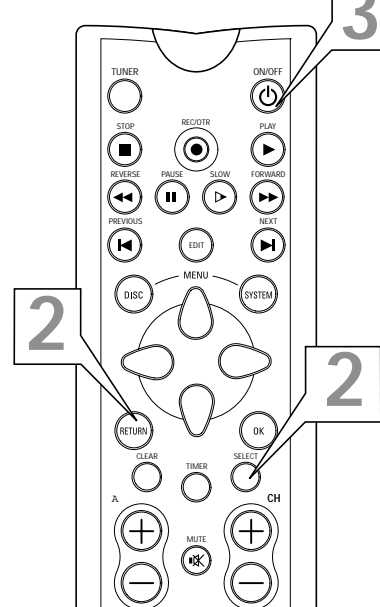

Using Your Recorder's Remote Control with Your TV (cont'd) 61

A	D	Inteq.....044	Osume.....099
AOC.....046,057	Daewoo.....119,046,401,	Interfunk.....064	Otto Versand.....064,037,
Acura.....036478,036,064,066	Intervision.....064,129,063,244,347,581
Admiral.....120,490	Dainichi.....245	Isukai.....245	P
Adyson.....244	Dansa.....064	J	Palladium.....397,445
Aiko.....119	Dayton.....036	JBL.....081	Panama.....244,291
Akai.....057	Daytron.....046	JCB.....027	Panasonic.....078,277,677
Akura.....245,291	Decca.....064,099	JVC.....080,063,398,680	Pathe Cinema.....347,243
Alaron.....206,243	Denon.....172	K	Pausa.....036
Alba 064,036,245,063,398	Dixi.....036,064	KEC.....207	Penney..074,087,057,048,
Allorgan.....321	Dual Tec.....244	KTV.....207,244,057,066	205,078,066,046,083,183
America Action.....207	Dumont.....044,046,097	Kaisui.....245,244,	Perdio.....347
Amplivision.....244	E036,243,309	Philco.....172,046,
Amstrad.198,398,036,064	Electroband.....027	Kamp.....243057,081,490
Anam.....207,036	Elin.....064	Kapsch.....233	Philips.....064,039,
Anitech.....036	Elite.....245,347	Kawasho.....243081,401,581
Arcam.....243,244	Elta.....036	Kendo.....064	Phonola.....064,039
Asuka.....245	Emerson.....263,207,205,	Kenwood.....057,046	Pilot.....046,057,066
Atlantic.....233	.206,490,309,066,046,181	Kingsley.....243	Pioneer.....136,193
Audiosonic.....064,136	Envision.....057	Korpel.....064	Portland.....046,066,119
Audiovox.....119,207,478	Erres.....039,064	Koyoda.....036	Prism.....078
Autovox.....233	Expert.....233	L	Profex.....036
B	F	LG.....083	Proline.....348
BPL.....309	Ferguson.....136,064	LXI..181,074,081,183,205	Proscan.....074
BSR.....321	Fidelity.....243	Leyco.....099,064,291,321	Protech.....064,129,036,
BTC.....245	Finlux.....064,132,097,	Liesenk & Tter.....064	458,244,291,445
Bang & Olufsen.....592099,206	Luma.....233	Proton.....205
Basic Line.....036,245	Firstline.....348,036,243,	Luxman.....083	Pulsar.....044,046
Baur.....064,037,581244,321	M	Pye.....039
Baysonic.....207	Fisher.....244,181,397	M Electronic.....132,244,	Q
Beaumarck.....205	Flint.....482036,064,136,401	Quasar..078,277,192,677
Beko.....397	Formenti.....347,064	MGA.....177,046,057,205	Quelle..064,097,037,581
Belcor.....046	Frontech.....458,291	MTC087,057,046,083,243	Questa.....063
Bell & Howell.....181	Fujitsu.....206,099,233	Magnadyne.....129	R
Beon.....064	Funai.....321,198,206,	Magnafon.....129	R-Line.....064
Binatone.....244207,291	Magnavox.....081,057,	RBM.....097
Blaupunkt.....581	Futuretech.....207063,206	RCA.....074,046,
Blue Sky.....245	G	Manesth.....347,244,291078,117,120
Blue Star.....309	GE.....048,074,078	Marantz.....064,081,057	Radio Shack.192,207,057,
Boots.....244205,478,120,309	Mark.....064205,066,181,
Bradford.....207	GEC.....099,064,244	Matsui..036,064,244,398,046,074,083
Brandt.....136	GPM.....245062,063,099,321	Radiola.....064,039
Britannia.....243	Geloso.....036	Matsushita.....277,677	Rank Arena.....063
Brockwood.....046	Genexxa.....245	Mediator.....039,064	Realistic.....192,207,181,
Broksonic.....263,490	Gibraltar.....044,046,057	Megatron.....172,205057,066,205,046,083
Bush.....064,398,245,036,	GoldStar.....064,046,057	Memorex.....205,036,083,	Revox.....064
.....063,309,321,401205,244,083,136177,181,277,490	Rex.....233,291
C	Goodmans.....064,099,206,	Midland..044,066,074,078	Rhapsody.....243
CCE.....064,244398,063,244,401	Minerva.....097,581	Roadstar 036,291,245,445
CS Electronics.....243	Gorenje.....397	Minutz.....048	Runco.....044,057
CXC.....207	Gradiente.....083,080	Mitsubishi.....063,135,177,	S
Candle.....057,083	Granada.....064,099,244205,046,120	SBR.....039,064
Carnivale.....057	Grandin.....309	Mivar.....243	SEG.....244,063,291
Carrefour.....063	Grundig.....097,581,064	Motorola.....120	SEI.....129,037,321
Carver.....081	Grunpy.....206,207	Multitech.....036,129,207,	SKY.....064
Cascade.....036	H243,244	SSS.....046,207
Cathay.....064	HCM.....036,309	N	Saba.....136
Celebrity.....027	Hallmark.....205	NAD.....183,193,205	Saisho.....036,291,458
Centurion.....064	Hanseatic.....064,347	NEC057,063,046,083,482	Sambers.....129
Cimline.....036	Harley Davidson.....206	NEI.....064,458	Sampo.....057,066
Cineral.....478,119	Harman/Kardon.....081	NTC.....119	Samsung.....064,046,205,
Citizen.....083,057,	Harvard.....207	Neckermann.....064,581244,291,397,036,
.....066,087,119	Hinari.....036,063,064,	Nesco.....206057,066,083,087,117
Clarivox.....064245,206	Netsat.....064	Samsux.....066
Clatronic.....397	Hisawa.....309,482	Nikkai...064,062,245,099,	Sandra.....243
Concerto.....083	Hitachi..136,071,172,244,243,291	Sansei.....478
Condor.....347,397063,083,132	Nikko.....205,057,119	Sansui.....490
Contec...036,063,207,243	Huanyu.....243,401	Noblisko.....129	Sanyo.....181,063,099
Craig.....207	Hypson.....291,064,309	Nordmende.....136	Schneider.....064,245,398
Crosley.....081	I	O	Scimitsu.....046
Crown.....397,036,064,	ICE.....244,291,398	Onwa.....207	Scotch.....205
.....066,207,445	ICeS.....245	Optimus 277,193,181,677	Scott263,046,205,206,207
Crystal.....458	ITS.....398	Optonica.....120,192	Sears.....181,083,183,074,
Curtis Mathes.....087,057,	Imperial.....445,397	Orion...321,490,064,206,081,198,205,206
.....066,074,078,081,083,	Indiana.....064263,347,348	Seleco.....233
.....120,172,181,193,478	Infinity.....081	Osaki.....099,244,245,291	Semivox.....207
Cybertron.....245	Inno Hit.....099	Oso.....245	Semp.....183
	Innova.....064		Sentra.....062
			Sharp.....120,192,063,066
			Shogun.....046
			Shorai.....321
			Siaram.....129
			Siemens.....581,064
			Silver.....063
			Sinudyne.....129,037,321
			Sonoko.....036,064
			Sontec.....064
			Sony.....037,063,027
			Soundesign...205,206,207
			Soundwave.....064,445
			Squareview.....198
			Standard.....244,245,036
			Starlite.....207
			Stern.....233
			Sunkai.....321,348
			Supra.....083
			Supreme.....027
			Susumu.....245
			Sylvania.....081,057
			Symphonic.....198
			Sysline.....064
			T
			TMK.....083,205
			Tandy...245,099,244,120
			Tashiko.....063,244
			Tatung.....099,244,064
			Tec.....244
			Technema.....347
			Technics.....078,277,677
			Technol Ace.....206
			Techwood.....078,083
			Teknika.081,206,207,046,
		066,119,083,087,177
			Telefunken.....136,083
			Telemeister.....347
			Teletech.....036
			Teleton.....233,063,244
			Tensai.....245,321,347
			Texet.....243,245
			Thomson.....136
			Thorn.....064,062,099
			Tomashi.....309
			Toshiba.....062,183,063,
		097,087,181
			Totevision.....066
			U
			Uher.....233,347
			Ultravox.....129
			Universum.....132,064,
		291,397
			V
			Vector Research.....057
			Vestel.....064
			Victor.....080
			Videotechnic.....244
			Vidikron.....081
			Vidtech.....046,063,205
			Vision.....347
			W
			Waltham.....244
			Wards...081,192,205,046,
		048,057,083,206
			Watson.....347,064
			Watt Radio.....129
			Wea.....063
			White Westinghouse.....
		347,064,243,490
			Y
			Yamaha.....046,057
			Yoko.....244,064,291,458
			Z
			Zanussi.....233
			Zenith.....044,119,490

62 Helpful Hints

If you are having problems with your product, check this list of problems and possible solutions before requesting service. You may be able to solve the problem yourself.

If you need to call a customer service representative, please know the model number and serial number of your product before you call. This information is on the rear of the product. Also, please take a moment to identify the problem you are having, and be prepared to explain this to the representative. If you believe the representative will need to help you with operations, please stay near the product. Our representatives will be happy to assist you.

No power

- Press the STAND BY / ON button on the front of the DVD Recorder to turn on the DVD Recorder.
- Make sure you connected the supplied power cord properly to the MAINS (AC power) jack on the rear of the DVD Recorder. Connect the power cord firmly to an AC power outlet. Use only the supplied power cord.
- Make sure the AC outlet has power by trying another appliance in the same outlet.

No picture

- Make sure the TV power is on.
- Check the video cables. Make sure the cable(s) are fastened securely to the DVD Recorder and to the TV.
- Set your TV to the correct Video In channel. These channels are usually near channel 00. Or, you may have a button on the TV remote control that selects an Auxiliary or A/V IN channel. See your TV owner's manual for details. Or, just change channels at the TV until you see the DVD Recorder's screen saver on the TV screen.
- You only need one video connection between the DVD Recorder and the TV. *Details are on page 9.*

Distorted picture

- Check the Disc for fingerprints. Clean the Disc with a soft cloth, wiping from the center to the edge in a straight line.
- Sometimes a small amount of picture distortion may appear. This is not a malfunction.

The picture is distorted or the picture is only black and white during DVD or Video CD playback.

- TVs have a color system standard, usually NTSC in the United States. If the Disc's or DVD Recorder's color system is different than your TV's color system, the picture may be distorted or colorless. *Details are on page 7.*

The sound is distorted during Disc playback through a Stereo.

- Make sure you did not connect any cables from the DVD Recorder to the Stereo's "PHONO IN" jack.
- Make sure you did not connect a digital jack on the Recorder (DIGITAL AUDIO OUT - OPTICAL or COAX) to an analog jack on the Stereo. (Analog audio jacks are usually labeled as such and are usually red and white.)

No sound

- Check the audio connections. *Details are on pages 9-15.* Remember, you only need one audio connection. See page 9 to see what connection best suits your situation.
- Make sure cables are connected firmly to all equipment.
- Select another channel, sound source, or Auxiliary station at your Stereo or TV. See your Stereo's manual or TV's manual for details. Or, just continue selecting the different sound sources or modes on the Stereo or TV until you hear sound from the Disc that is in the DVD Recorder. *Details are on pages 9-15.*
- Check your Analog output settings or Digital output settings. Make sure you choose the right setting, based on what equipment you connected to the DVD Recorder. *Details are on pages 56-57.*
- Make sure your Analog output settings or Digital output settings match the capabilities of your Stereo Receiver or TV. *Details are on pages 56-57.*

Disc will not play.

- Make sure the Disc label is facing up. If you are playing a two-sided Disc, make sure the side you want to play is facing up. *Details are on page 18.*
- Check the Access Control settings for the Disc. *Details are on pages 49-53.*
- Check the Region Code of the DVD. The DVD must be coded for All regions or Region 1 in order to play on this DVD Recorder. *Details are on page 7.*
- See if the Disc is defective by trying another Disc. Make sure the Disc is not scratched or warped. Carefully clean the Disc. *Details are on page 6.*
- Use a commonly available cleaning CD/DVD to clean the lens of the DVD Recorder.
- A DVD+RW recorded on a different brand of Recorder can play on the Philips DVD Recorder, but all its features may not be accessible. However, you may be able to adapt the disc format so you can access the Disc's original features. *Details are on page 54.* If the Disc is protected, you can not adapt the disc format.

The DVD logo does not appear on the TV screen after you remove a Disc.

- Reset the DVD Recorder by switching it off, then on again.

The DVD Recorder does not respond to the remote control.

- Aim the remote control directly at the sensor on the front of the DVD Recorder. *Details are on page 22.* Point the remote control toward the DVD Recorder, not your TV.
- Remove any obstacles between the DVD Recorder and the remote control.
- Inspect or replace the batteries in the remote control. *Details are on page 8.*
- The remote control may have been set to operate another DVD Recorder accidentally. Press and hold the SELECT and Number 1 buttons on the remote control at the same time to have the remote control operate the DVD Recorder.

The DVD Recorder will not select some features, such as Angles, Subtitles, or multi-language Audio.

- The feature may not be available on the Disc. If it is not, an "X" will appear on the TV screen. Check the Disc case to see if the Disc has the feature. If the Disc does not have the feature, the DVD Recorder cannot create the feature. This is not a malfunction of the DVD Recorder.

You can not record a new Title.

- See if the Disc already has the maximum number of titles. Delete some recordings if necessary. *Details are on page 44.*
- You can record only if the Disc is Unprotected. *Details are on page 47.*







The Index Picture Screen does not appear, but the Disc still plays.

- Clean the Disc. *Details are on page 6.*
- Adapt the disc format if possible. *Details are on page 54.*

A DVD player shows the Index Picture Screen but does not react to PLAY ►.

- Press STOP ■ to exit the Index Picture Screen, then press PLAY ►.

You need to access system information for service reasons.

- Press SYSTEM MENU.   may be selected. If it is not, press  to select it. Press  repeatedly to select , then press . Press  repeatedly until the system information appears.

The DVD Recorder does not work.

- Disconnect the power cord from the Recorder and the power outlet for a few minutes. Reconnect the power cord and try to operate the Recorder again as usual. If the DVD Recorder still will not operate, disconnect the power cord from the Recorder again. Then, while pressing and holding the STAND BY/ON button on the front of the Recorder, reconnect the power cord. This resets the DVD Recorder to the factory mode, or to its original settings as they were when you first received the Recorder. You will have to complete the Initial Setup again and reset any items you have adjusted during your use of the Recorder.

Strange codes appear on the Recorder's display.

- Remove and reinsert the Disc.
- Clean the Disc.
- Disconnect the power cord from the power outlet, then reconnect the cord and try playback as usual.

64 Glossary

AC-3: Audio Coding 3, also known as Dolby Digital; a multi-channel digital audio compression system from Dolby Labs.

Analog: Sound that has not been turned into numbers. Analog sound varies, while digital sound has specific numerical values. Analog sound is available when you use the red and white audio jacks on your equipment. These jacks send audio through two channels, the left and right.

AUDIO OUT Jacks: Jacks on the rear of the DVD Recorder that send audio to another system (TV, Stereo Receiver, etc.).

A/V: Audio/Video.

CD: Compact Disc.

Chapter: A part of a Title.

COAX (coaxial) jack: Sends digital audio to a Stereo Receiver, allowing you to adjust the volume at the Receiver. The Receiver must have a coaxial jack. This connection provides the 5.1 channel surround sound as heard in movie theaters.

COMPONENT VIDEO Jacks: The OUT jacks on the rear of the DVD Recorder send high-quality video to a TV that has Component Video In jacks. The IN jacks allow the Recorder to receive high-quality video from other equipment, such as a DVD Player.

Digital: Sound that has been converted into numerical values. Digital sound is available when you use the COAX (coaxial) or OPTICAL DIGITAL AUDIO OUT jacks on the Recorder. These jacks send audio through multiple channels, instead of just two channels as analog does.

Dolby Digital: A surround sound system that provides 5.1 channel sound as used in movie theaters.

DTS: Digital Theater Systems. This is a surround sound system, but it is different from Dolby Digital. The formats were developed by different companies.

DVD: Digital Video Disc.

DVD+RW: DVD+ReWritable. The disc standard used by the DVD Recorder.

i.LINK: Also known as 'FireWire' and 'IEEE 1394.' A cable for transfer of high bandwidth digital signals as used by Digital Video camcorders.

Index Picture Screen: A screen that gives an overview of a DVD+RW. An Index Picture represents each recording.

Letterbox: Widescreen format; a TV aspect ratio setting (4:3). Displays the video in full-width, with black bars at the top and bottom of the TV screen. This format is similar to seeing a movie in a theater. If the Disc does not include a letterbox format, selecting 4:3 letterbox may have no effect. (For example, some DVDs are two-sided, with one side playing in widescreen format and the other side playing in a normal format.)

MPEG: Motion Picture Experts Group. A collection of compression systems for digital audio and video.

OPTICAL Jack: Converts electrical signals into optical signals before sending the audio to the Stereo Receiver. Optical audio is not prone to external electrical influences and has less noise, which reduces adverse effects on external equipment. Be sure to keep the protective cap on the jack when the jack is not in use. This keeps dust out of the jack.

OTR: One-Touch Recording. Start a timed recording by pushing just one button; select the switch-off time in intervals of 30 minutes.

Pan & Scan: A TV aspect ratio setting (4:3). Displays the video with full-height picture, with one or both sides of the picture trimmed to fit on your TV screen. Some movie companies refer to this as "reformatting the picture to fit your TV screen."

PBC: Playback Control. A special feature on a Video CD or Super VCD that enables interactive use.

PBS: Public Broadcast System. The channel transmits data for Automatic clock setting.

PCM: Pulse Code Modulation. A digital audio encoding system.

RGB: Red-Green-Blue. A top-quality video connection where red, green and blue components of a video signal are carried through separate wires. This also is referred to as the component video connection.

S-Video: Produces a clearer picture by sending separate signals for the luminance and the color. If you connect the supplied S-Video cable, you will not need to use the supplied yellow video cable. You can use S-Video only if your TV has an S-Video In jack.

Title: A unit of recording on a Disc. A Title typically represents one recording on a DVD+RW.

TruSurround: A system that simulates multi-channel sound via a two-channel connection (audio left and right).

TV system: There are various systems for transmitting television signals, for example PAL, SECAM, and NTSC. NTSC is the most common color system in the United States of America. The TV system is country dependent. The Recorder automatically selects the right TV system.

VCD: Video Compact Disc

VCR: Video Cassette Recorder

VCR Plus+: Allows you to set a timer recording by entering a code from your TV guide.

VIDEO OUT Jack: Jack on the rear of the DVD Recorder that sends video (picture) to a TV.

Widescreen: A TV aspect ratio setting (16:9). Displays the video appropriately when you connect the DVD Recorder to a widescreen TV.

If you are still having trouble with the Recorder after checking Helpful Hints and other information in this manual, you may perform a Diagnostic Test on the Recorder. Follow the steps below.

- 1** Disconnect the power cord from the Recorder.
- 2** Press and hold the **PLAY ►** button on the front of the Recorder while you reconnect the power cord to the Recorder. "BUSY" will appear on the display panel, along with a counter number. **Continue to hold down PLAY ►**. The counter will reach zero (0) when the test is finished. **Release PLAY ►**.
- 3** Momentarily, "FAIL" or "PASS" will appear on the display panel.
If "FAIL" appears, your Recorder needs repair. Contact the Philips Customer Care Center for the Authorized Service Center nearest you.
If "PASS" appears, the Recorder apparently has no failure. The problem may be incorrect interpretation of the operating instructions, a wrong Disc in use, or incorrect connections. Contact the Philips Customer Care Center for further assistance in solving the problem.
- 4** If there is no failure, disconnect the power cord again, then reconnect it to the Recorder and an AC power outlet. The DVD Recorder will be ready for regular use.

66 Specifications

DISC FORMATS SUPPORTED

Disc type	Playback	Recording
DVD+RW	•	•
DVD-RW (Video format)	•	—
DVD-R	•	—
DVD-Video	•	—
SVCD	•	—
Video CD	•	—
Audio CD	•	—
CD-R	•	—
CD-RW	•	—

DVD+REWRITABLE DISC FORMAT

Medium	Phase-Change ReWritable
Diameter	12 cm
Capacity (single side)	4.7 Gbyte
Recording time	HQ 60 minutes SP 120 minutes LP 180 minutes EP 240 minutes

TV STANDARD

	PAL/SECAM	NTSC
Scan Frequency	50Hz	60Hz
Number of lines	625	525
Playback	•	•
Recording	•	•
Internal tuner	—	•

VIDEO FORMAT

Digital Compression	MPEG2 for DVD MPEG1 for VCD
---------------------	--------------------------------

VIDEO RESOLUTION

	50Hz	60Hz
DVD-Video/ DVD+RW(HQ/SP)		
• Horiz.Resolution	720 pixels ¹	720 pixels ¹
• Vertical Resolution	576 lines	480 lines
DVD+RW (LP/EP)		
• Horiz.Resolution	360 pixels ²	360 pixels ²
• Vertical Resolution	576 lines	480 lines
VCD		
• Horiz.Resolution	352 pixels	352 pixels
• Vertical Resolution	288 lines	240 lines

¹ equivalent to 500 lines on your TV

² equivalent to 250 lines on your TV

VIDEO PERFORMANCE

DA Converter	10-bit
AD Converter	9-bit
Signal handling	Components
Video Output	1 Vpp into 75 Ohm
S-video Output	Y: 1 Vpp into 75 Ohm C: 0.300 Vpp into 75 Ohm
Component/ Progressive out	Y: 1 Vpp into 75 Ohm P _B : 0.7 Vpp into 75 Ohm P _R : 0.7 Vpp into 75 Ohm

CABINET

Dimensions (w x h x d): 17 x 4.3 x 13 inches
Net weight: 8.8 kg
Front Panel: Aluminum

AUDIO FORMAT

	Playback	Recording
Compressed digital	Multi-channel	2-channel
• Dolby Digital (AC-3)		16 bit, fs 48 kHz
• DTS	Multi-channel	—
• MPEG1	2-channel	—
• MPEG2	Multi-channel	—
Uncompressed digital (SP dif)		
• PCM	2-channel	—
	16, 20, 24 bit fs 48, 96 kHz	

AUDIO PERFORMANCE

DA Converter	24 bit
AD Converter	16 bit
DVD	fs 96 kHz 4 Hz -44 kHz fs 48 kHz 4 Hz -22 kHz
Video CD	fs 44.1 kHz 4 Hz -22 kHz
Audio CD	fs 44.1 kHz 4 Hz -20 kHz
Signal-Noise (1kHz)	105 dB
Dynamic Range (1kHz)	100 dB
Crosstalk (1kHz)	110 dB
Distortion/Noise (1kHz)	90 dB

FRONT CONNECTIONS

i.LINK DV	IEEE 1394 4-pin
S-video Input	Hosiden 4-pin*
Video Input	Cinch (yellow)*
Audio Left/Right Input	Cinch (white/red)*

REAR CONNECTIONS

Component Video In	Cinch (green/blue/red)*
Component Video Out	Cinch (green/blue/red)*
Progressive Scan Out	Cinch (green/blue/red)*
S-video In	Hosiden 4-pin
S-video Out	Hosiden 4-pin
Video In	Cinch (yellow)*
Video Out (2x)	Cinch (yellow)*
Audio L/R In (2x)	Cinch (white/red)*
Audio L/R Out (2x)	Cinch (white/red)*
Digital Audio Out	1 coaxial*, 1 optical IEC958 for CDDA /LPCM IEC1937 for MPEG2, Dolby Digital
RF Antenna In	Coaxial 75 ohms
RF TV Out	Coaxial 75 ohms
Power	Standard (IEC type)

* gold-plated

POWER SUPPLY

AC power:	polarized (IEC)
Power supply	100 -120V AC 50/60 Hz
Power consumption	Operation 36 W Low-power standby 3 W

Limited Warranty 67

DVD Recorder

Two years Free Labor / Two years Exchange Warranty on Parts
This product must be carried in for repair.

WHO IS COVERED?

You must have proof of purchase to receive warranty service. A sales receipt or other document showing that you purchased the product is considered proof of purchase.

WHAT IS COVERED?

Warranty coverage begins the day you buy your product. For two years thereafter, all parts will be repaired or replaced, and labor is free. After two years from the day of purchase, you pay for the replacement or repair of all parts, and for all labor charges.

All parts, including repaired and replaced parts, are covered only for the original warranty period. When the warranty on the product expires, the warranty on all replaced and repaired parts also expires.

WHAT IS EXCLUDED?

Your warranty does not cover:

- labor charges for installation or setup of the product, adjustment of customer controls on the product, and installation or repair of antenna systems outside of the product.
- product repair and/or part replacement because of misuse, accident, unauthorized repair or other cause not within the control of Philips Consumer Electronics.
- reception problems caused by signal conditions or cable or antenna systems outside the unit.
- a product that requires modification or adaptation to enable it to operate in any country other than the country for which it was designed, manufactured, approved and/or authorized, or repair of products damaged by these modifications.
- incidental or consequential damages resulting from the product. (Some states do not allow the exclusion of incidental or consequential damages, so the above exclusion may not apply to you. This includes, but is not limited to, prerecorded material, whether copyrighted or not copyrighted.)
- a product that is used for commercial or institutional purposes (including but not limited to rental purposes).

WHERE IS SERVICE AVAILABLE?

Warranty service is available in all countries where the product is officially distributed by Philips Consumer Electronics. In countries where Philips Consumer Electronics does not distribute the product, the local Philips service organization will attempt to provide service (although there may be a delay if the appropriate spare parts and technical manual(s) are not readily available).

MAKE SURE YOU KEEP...

Please keep your sales receipt or other document showing proof of purchase. Attach it to the owner's manual and keep both nearby. Also keep the original box and packing material in case you need to return your product.

BEFORE REQUESTING SERVICE...

Please check your owner's manual before requesting service. Adjustments of the controls discussed there may save you a service call.

TO GET WARRANTY SERVICE IN U.S.A., PUERTO RICO OR U.S. VIRGIN ISLANDS...

Take the product to a Philips factory service center (see enclosed list) or authorized service center for repair. When the product has been repaired, you must pick up the unit at the center. Centers may keep defective parts. (In U.S.A., Puerto Rico and U.S. Virgin Islands, all implied warranties, including implied warranties of merchantability and fitness for a particular purpose, are limited in duration to the duration of this express warranty. Because some states do not allow limitations on how long an implied warranty may last, this limitation may not apply to you.)

TO GET WARRANTY SERVICE IN CANADA...

Please contact Philips at:

1-800-661-6162 (French Speaking)

1-800-363-7278 (English Speaking)

(In Canada, this warranty is given in lieu of all other warranties. No other warranties are expressed or implied, including any implied warranties of merchantability or fitness for a particular purpose. Philips is not liable under any circumstances for any direct, indirect, special, incidental or consequential damages, howsoever incurred, even if notified of the possibility of such damages.)

REMEMBER...

Please record below the model and serial numbers found on the product. Also, please fill out and mail your warranty registration card promptly. It will be easier for us to notify you if necessary.

MODEL # _____

SERIAL # _____

This warranty gives you specific legal rights. You may have other rights which vary from state/province to state/province.

Philips Service Solutions Group, P.O. Box 2976, Longview, Texas 75606, (903) 242-4800

Information Index

a/ch button.....21	edit button.....21	pbs channel.....38-39	3D sound.....25, 31, 57
ac power cord.....10-14, 24	editing.....48	pcm only.....56	time.....38-39
access control.....49-53	ep.....46	picture settings.....55	time search.....25, 33
adapt disc format.....54	erase disc.....47	play always.....51	time zone.....38-39
add/delete channels.....36	erase this title.....44	play button.....18, 21-22	timer button.....21, 41-43
analog output.....31, 57	error messages.....43	play full title.....44	timer information box.....27, 35
analog sound.....31, 57		play once.....51	timer recordings.....41-43
angle.....26, 30	fast forward searching.....25, 32	playable discs.....7	title buttons.....22
angle button.....21, 30	fast motion.....25	playback control.....54	title menus.....28
append recording.....45	favorite scene selection.....48	playing a disc.....18	title settings menu.....44
arrow buttons.....18, 20, 25, 28	forward button.....21, 32	pluscode.....42	titles.....25
audio button.....20, 29	frame-by-frame playback.....25, 31	power cord.....10-14, 24	tuner button.....20
audio in/out jacks.....9-13, 15, 22, 24	front panel.....22	previous button.....21	tuner information box.....27, 35
audio language.....16, 58	glossary.....64	prog scan out (Y, Pb, Pr) jacks.....10, 24	tracks.....25, 28
auto chapters.....46	helpful hints.....62-63	progressive scan.....10	tv shape.....17, 55
auto man rec volume button.....22	hidden chapter.....48	protection.....47	tv switch.....20, 60
auto resume.....54	hookups.....9-15		tv system.....7
automatic channel programming.....36	hq.....46	rear panel.....24	user preference settings.....25, 54
batteries.....8	index picture screen.....35	rec/otr button.....20	vcr plus+ programming.....37, 42
black level shift.....55	information boxes.....27	record button.....22	video cd.....7-8
cam1/cam2/cam3.....22	initial setup.....16-17	record mode.....46	video (cvbs) in/out jacks.....15, 24
camera angle.....26, 30	insert chapter marker.....48	record settings.....46	video (cvbs) in/out jacks.....15, 24
change code.....49	installation.....36-39	recording audio.....58	video input channel (tv).....9
change country.....53	key sound.....59	region codes.....7	video shift.....55
channel buttons.....21-22	language.....16-17, 58	remote control, buttons.....20-21	visible chapter.....48
channel programming.....36	letterbox.....55, 64	remote control, settings.....59	vol(ume) buttons.....20
chapter markers.....46	limited warranty.....67	remote control, tv operation.....60-61	warranty.....67
chapters.....28, 46, 48	lock/unlock.....50	remote sensor.....22	widescreen tv.....55
child lock.....50	low power standby.....54	repeat a-b.....26, 34	"x".....8
cleaning discs.....6	lp.....46	repeat a-b button.....21, 34	zoom.....25, 30
clear button.....21	lp/ep rec mode.....46	repeat button.....21, 34	zoom button.....20, 30
clock.....38-39	make edits compatible.....47	repeat playback.....34	
code (access control).....49	manual buttons.....22	return button.....20	
color systems.....7	manual recording volume.....45	reverse button.....21, 32	
component video in/out jacks.....9-10, 24	menu bars.....25	reverse searching.....32	
connections.....9-15	menu language.....16, 58	safe.....26, 51	
contents of package.....6	menus.....8, 25, 28	safety precautions.....4-6	
contents, table of.....3	mute button.....20	sap.....58	
controls, remote.....20-21	name.....44	scan.....20, 26, 33	
daylight saving.....38-39	new index picture.....48	scan button.....20, 33	
delete all markers.....48	next button.....21	search buttons.....22	
delete chapter marker.....48	night mode.....59	searching.....32	
diagnostic test.....65	ntsc.....7	select button.....20, 41	
digital audio.....9, 14, 56	number buttons.....21	slow button.....21, 32	
digital output.....56	ok button.....20	slow motion.....25, 32	
digital sound.....56	on/off button.....20	sound mode.....25, 31, 57	
dim button.....20	on-screen symbols.....26	sp.....46	
disc bar.....35	one-touch recording.....40	specifications.....66	
disc information screen.....47	open/close button.....22	st (stereo).....25, 31, 57	
disc lock.....49-53	optical (digital audio out) jack.....14, 24, 56	stand by /on button.....22	
disc menu button.....20, 28	pal.....7	status box.....26, 54	
disc menus.....28	panel button.....22	stereo.....25, 31, 57-58	
disc name.....47	panscan.....55	still picture.....31	
disc pointer.....35	parental level.....52	stop button.....18-20, 22	
disc tray.....18	password (access control).....49	subtitle button.....21, 29	
display.....23	pause button.....21, 31	subtitles.....17, 25, 29, 58	
divide title.....48	pbc.....54	sur (surround).....25, 31, 57	
dolby surround.....13, 31, 57		svcd.....7	
dts (digital surround).....14		s-video.....9, 11, 15, 22, 24	
dvd ilink.....22		s-video in/out jacks.....22, 24	
dvd video.....7		system menu button.....20, 25	
		T-C button.....21	
		table of contents.....3	

