

OWNER'S GUIDE

THREE POINT HITCH

Model Number
190-951-000

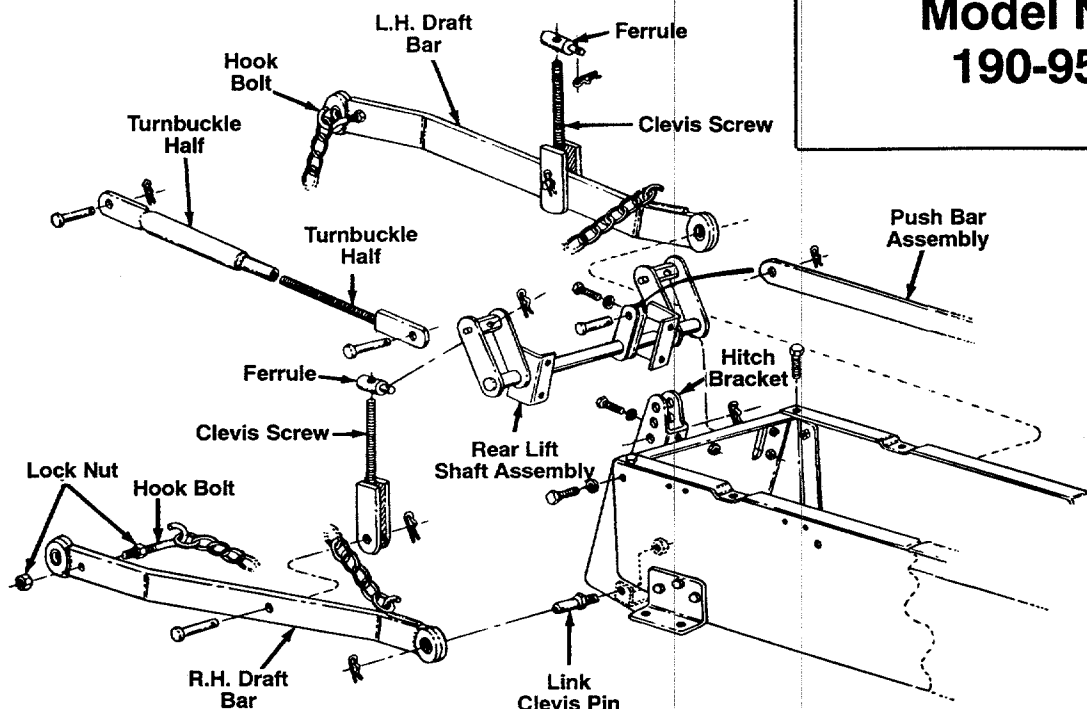

FIGURE 1.

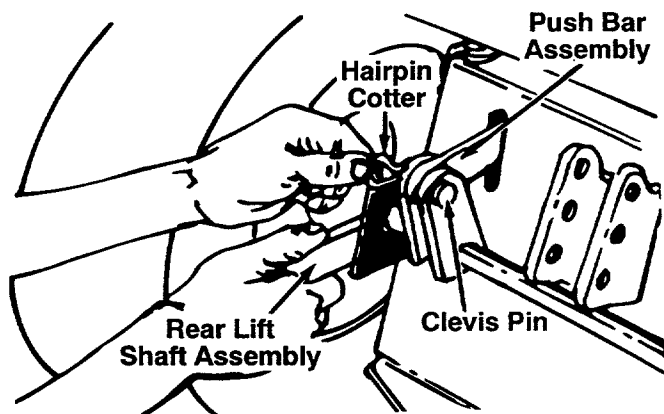

FIGURE 2.

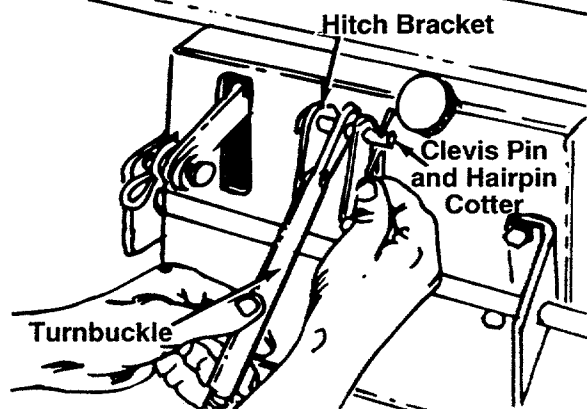

FIGURE 3.

THREE POINT HITCH ASSEMBLY

The three point hitch is needed for the rotary tiller, disc, cultivator and moldboard plow. To use the mowing deck, snow thrower or snow blade, it is not necessary to install the three point hitch.

1. Raise the lift shaft assembly until the hole lines up with the slot in the push bar assembly. See figure 2.
2. Secure with clevis pin and hairpin cotter provided in the hardware pack.
3. Assemble the two draft bars to the link clevis pins in the frame of the tractor with two hairpin cotters.

NOTE: Refer to figure 1 to determine right and left hand draft bars.

4. Thread the ferrule onto the clevis screw until approximately a half inch of thread is showing above the ferrule.
5. Attach the ferrules to the rear lift shaft assembly and secure with two hairpin cotters.
6. Attach the lower end of the clevis screw to the draft bars with the two clevis pins and hairpin cotters.
7. Screw the two halves of the center turnbuckle together. Attach either end to any hole in the hitch bracket mounted in the center of the rear frame of the tractor with a clevis pin and hairpin cotter. See figure 3.

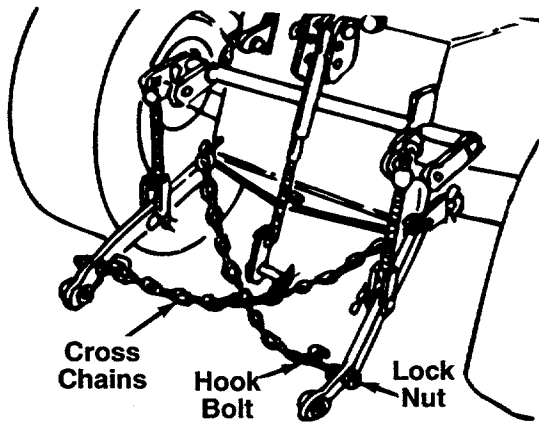

8. Screw one hex nut all the way on to each of the hook bolts.
9. Insert the hook bolt through the inside of the draft bars. Secure with a second nut. Do not tighten.
10. Fasten the chains to the hooks welded on the draft bars. Cross the chains over and attach to the opposite hook bolts. See figure 4.
11. Tighten the outside nuts on the hook bolts until there is approximately one inch of play in the center of the chains.

NOTE: Pull the chains to make them as tight as possible.

FIGURE 4.

Model 951

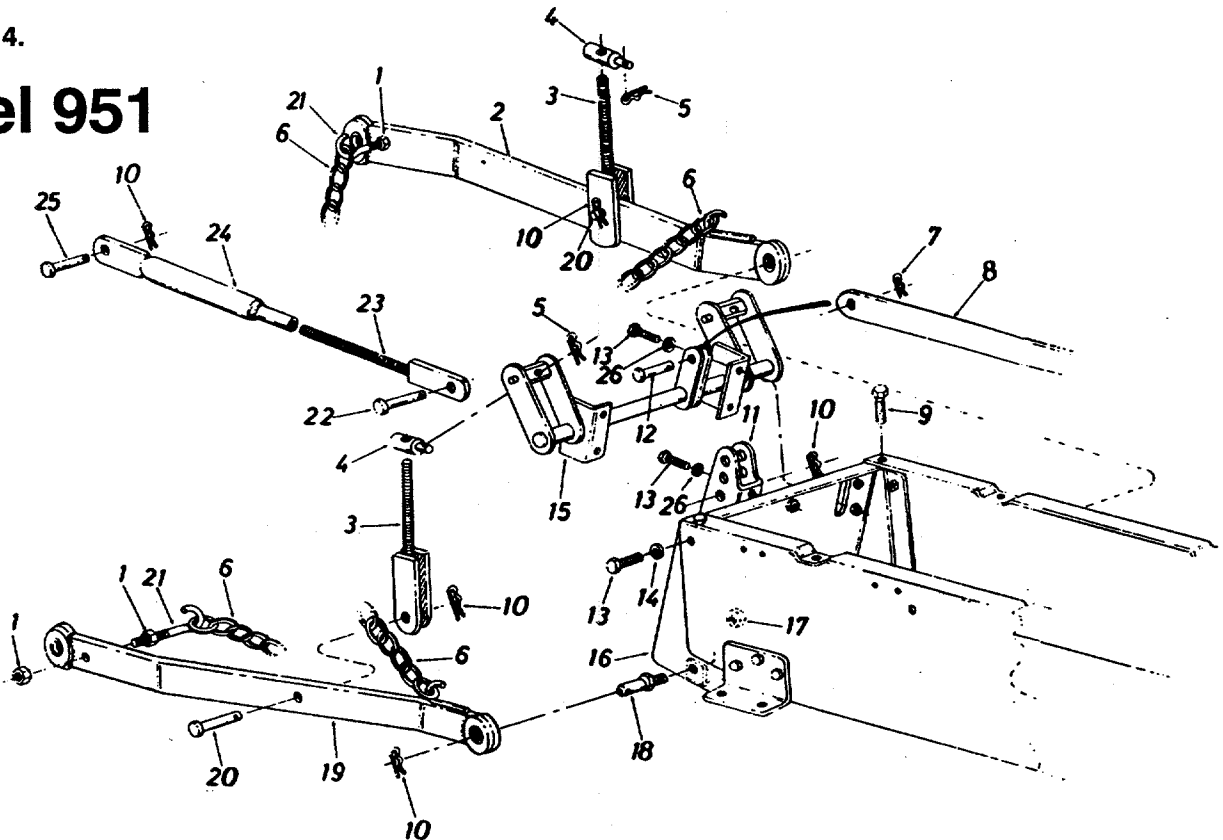

PARTS LIST FOR MODEL 951 THREE POINT HITCH

REF. NO.	PART NO.	CODE	DESCRIPTION	REF. NO.	PART NO.	CODE	DESCRIPTION
1	712-0290		Hex Cent. L-Nut 7/16-14 Thd.	14	736-0217		L-Wash. 3/8" I.D.—H.D.*
2	13130A		Draft Bar Ass'y.—L.H.	15	13135		Rear Lift Shaft Ass'y.
3	13138		Clevis Screw Ass'y.	16	13196		Hitch Plate Ass'y.
4	711-0649		Clevis Pin	17	712-0923		Hex Cent. L-Nut 5/8-18 Thd.
5	714-0147		Hitch Pin Clip	18	711-0497		Link Clevis Pin
6	713-0148		Chain—20 Links	19	13129A		Draft Bar Ass'y.—R.H.
7	714-0470		Cotter Pin 1/8" Dia. x 1.25**	20	711-0225		Clevis Pin .63" Dia. x 1.66"
8	13709		Push Bar Ass'y.	21	711-0639		Hitch Chain Hook
9	710-0216		Hex Bolt 3/8-16 x .75" Lg.*	22	711-0299		Clevis Pin .63" Dia. x 2.4" Lg.
10	714-0117		Hairpin Cotter	23	711-0636		Clevis Screw
11	13026		Hitch Brkt.	24	749-0238		Clevis Tubing
12	711-0654		Clevis Pin	25	711-0299		Clevis Pin .63" Dia. x 2.4" Lg.
13	710-0216		Hex Bolt 3/8-16 x .75" Lg.*	26	736-0217		L-Wash. 3/8" I.D.—H.D.

For Replacement Parts, Contact:

SERVICE DEPARTMENT • P.O. BOX 368022 • CLEVELAND, OHIO 44136-9722

FORM NO. 770-6807
R940517