



FilterStream®

ADVANCED CLEANING APPLIANCES™

DustTamer ULTRA® D4500

IMPORTANT SAFEGUARDS	4
<hr/>	
ABOUT YOUR DUSTTAMER ULTRA®	6
<hr/>	
DUSTTAMER ULTRA® DESCRIPTION	7
<hr/>	
BATTERY CHARGING PROCEDURE	8
<hr/>	
2-STAGE HEPA FILTRATION	10
<hr/>	
LAMBSWOOL DUSTER	11
<hr/>	
DUSTING	11
<hr/>	
CLEANING LAMBSWOOL DUSTER WITH VACUUM CHAMBER	12
<hr/>	
LAMBSWOOL DUSTER STORAGE	14
<hr/>	
MAINTENANCE	15
Emptying/Cleaning the Dust Drawer	
Cleaning/Replacing the HEPA Filter	
Cleaning the DustTamer Ultra®	
<hr/>	
BATTERY REMOVAL/DISPOSAL	18
<hr/>	
ACCESSORIES	19
<hr/>	
WARRANTY	Back Cover

Congratulations!

You now own a top-quality FilterStream® DustTamer Ultra® Vacuum Powered Duster. To ensure maximum satisfaction, please take a few moments to review the following important information before using this item.

Thank You!

When using electrical appliances, always follow basic precautions, including the following:

PLEASE READ ALL INSTRUCTIONS CAREFULLY BEFORE USING THIS APPLIANCE

WARNING:

To reduce the risk of fire, electrical shock or injury:

- Close supervision is necessary when any appliance is used by or near children. Do not allow this appliance to be used as a toy.
- Do not use without the Dust Drawer and HEPA filter in place. Replace a damaged filter promptly.
- To protect against risk of electrical shock: (i) do not put vacuum chamber or charger in water or other liquid, and (ii) do not insert a wet duster into the vacuum chamber
- Do not put anything that is burning or smoking, such as cigarettes, matches, or hot ashes into the vacuum chamber.
- Avoid putting hard, sharp objects in the vacuum chamber. They may damage the vacuum chamber and the filters.
- Do not use this product to pick up toxic substances, flammable or combustible liquids such as gasoline or operate in the presence of explosive or flammable fumes. Do not immerse the vacuum chamber in any liquid.
- Do not operate in the presence of explosives and/or flammable fumes or liquids.
- Do not unplug the charger by pulling on the cord. Never carry the charger or vacuum chamber by the cord or yank to disconnect from an outlet; instead, grasp the charger and pull to disconnect. Do not pull cord around sharp edges or corners.
- Do not allow the cord to hang over the edge of a table or counter or touch hot surfaces. The vacuum chamber should be placed away from sinks and hot surfaces.
- The use of an extension cord is not recommended. Only plug the charger into a standard electrical outlet (120V/60 Hz).
- Use only the charger supplied with this unit to recharge the vacuum chamber.

- Do not attempt to use the charger with any other product.
- Never handle the plug or vacuum chamber with wet hands.
- Do not operate with a damaged cord or charger. If the vacuum chamber has been dropped into water or if it malfunctions, return the unit to the store where it was purchased.
- Unplug the charger from outlet before any routine cleaning or maintenance of the vacuum chamber.
- Do not put any object into openings. Do not use with any opening blocked; keep free of dust, lint, hair, or anything that may reduce airflow.
- Do not use on or near hot surfaces.
- Use extra care when cleaning on stairs.
- This vacuum chamber is intended for household use only and not for commercial or industrial use.
- Use only as described in this manual. Use only FilterStream® DustTamer® accessories and filters.
- The vacuum chamber should be unplugged before turning on the unit.
- This product contains nickel cadmium (Ni-cad) batteries. Do not incinerate the batteries as they will explode at high temperatures. Always dispose of the batteries in accordance with your state's laws. Please call 1-800-822-8837 for disposal instructions and drop off locations in your area.
- Leaks from a battery cell can occur under extreme conditions. If the battery liquid gets on skin: (i) wash immediately with water. If it gets in your eyes, immediately flush your eyes with a mild solution of baking soda and water and seek medical attention.

**SAVE THESE
INSTRUCTIONS**

The revolutionary DustTamer Ultra®, the world's first dusting appliance, makes dusting faster, easier and cleaner!

With DustTamer Ultra®, there's no more brushing of allergy causing dust back and forth and into the air, and no more wasted time with slow, messy dusting cloths.

To use, you simply dust your home with the professional quality Australian lambswool duster and conveniently suction off the dust on-the-spot with the cordless, rechargeable vacuum chamber!

To ensure that only clean, dust and allergen free air re-enters your home, DustTamer Ultra® utilizes a 2-stage HEPA filtration system that captures 99.97% of dust and allergens.

Your DustTamer Ultra® D4500 comes complete with a handy 22" duster, a Dust Drawer containing a washable/reusable Stainless Steel Pre-Filter and a certified HEPA filter.

Please follow this manual for the proper set-up, use, and care of this revolutionary cleaning product.

Your DustTamer Ultra® Vacuum Powered Duster contains the following parts:

- 1 Vacuum Chamber Housing
- 2 AC Adapter
- 3 Lambswool Duster (22")
- 4 Duster Hanging Hook
- 5 Dust Agitation/Suction Vents
- 6 Dust View Window
- 7 Dust Drawer with Stainless Steel Pre-Filter Screen
- 8 HEPA Filter
- 9 On/Off Switch
- 10 Carrying Handle
- 11 Battery Compartment (located on bottom of unit)
- 12 Motor and Fan
- 13 Air Exhaust
- 14 AC Adapter Jack (located at the bottom rear of unit)

DUSTTAMER ULTRA® DESCRIPTION



BATTERY CHARGING PROCEDURE

Your DustTamer Ultra® uses a cordless, rechargeable Vacuum Chamber to suction dust off your DustTamer® Duster. When fully charged, your Vacuum Chamber will have enough power to clean your Duster dozens of times.

To charge your DustTamer Ultra®, please do the following:

1. Remove the supplied AC Adapter from the Carton and connect it to the AC Adapter Jack located at the rear bottom of the Vacuum Chamber and plug the AC Adapter into a wall outlet. (See figure 1)

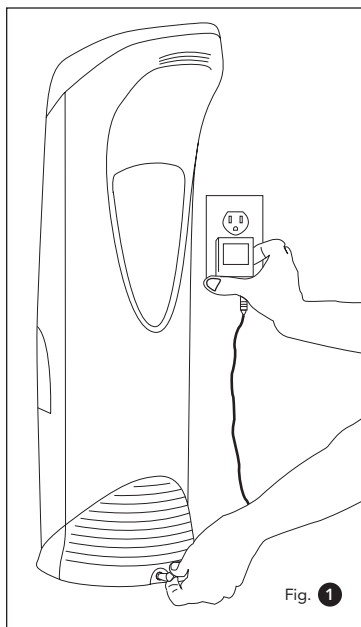

Fig. 1

Important: Before first use, charge your DustTamer Ultra® for at least 24 hours.

Note 1: To maintain a charge, keep the AC Adapter and Vacuum Chamber plugged into a standard wall outlet at all times. When charging, the AC Adapter may be warm to the touch. This is normal.

The Vacuum Chamber can be left in one location during dusting, (bringing the Duster back to it for cleaning) or you can carry the Vacuum Chamber with you from room to room for extra convenience. (See figure 2)

Note 2: As with many rechargeable products, we recommend that the AC Adapter not be plugged into the wall outlet when the unit is in use (i.e. while cleaning the Duster with suction action).



Fig. 2

2-STAGE FILTRATION SYSTEM

Traditional dusting tools push allergy causing dust from one spot to another or into the air. With its 2-stage HEPA filtration system, DustTamer Ultra® overcomes this problem. (See figure 3)

Stage 1: A reusable, washable Dust Drawer containing a Stainless Steel Pre-Filter Screen traps larger dust particles for clean and easy removal when full (see “Maintenance” section of this manual for emptying instructions).

Stage 2: An included FilterStream® certified HEPA Filter captures 99.97% of microscopic dust particles, pollen, bacteria and other allergens down to 0.3 microns in size.



Fig. 3



Your DustTamer Ultra® includes a professional quality 100% Lambswool Duster made in Australia.

Lambswool dusters are the choice of cleaning professionals because they are:

Fast - the large head covers large areas quickly

Superior at Dust Pick Up - lambswool has natural dust grabbing fibers, electrostatic action and lanolin oil that attracts and holds dust like a magnet

Incredibly Soft & Versatile - won't scratch delicate items; great for small figurines or large tables

Reusable - saves time and money!

DUSTING

The included Lambswool Duster is ideal for cleaning any areas where dust accumulates:

- Venetian blinds
- lamps
- louvered doors
- fine furniture
- collectibles
- televisions/stereo equipment
- plant leaves
- computer monitors/keyboards
- automobile dashboards

For helpful dusting & cleaning tips, see our handy DustTamer® Cleaning Tips booklet included with your DustTamer Ultra®.

1. Your DustTamer Ultra® Vacuum Chamber can be conveniently carried from room to room operating on battery power.
2. The number of times you clean your Lambswool Duster in the Vacuum Chamber will be determined by the amount of dust you pick up. Rooms with heavy dust accumulation may require several cleanings, whereas small rooms or quick touch-up dusting may only require one cleaning.

Your DustTamer Ultra® is designed to clean everyday household dust, not thick, decades old dust found in attics, garages, warehouses, etc.

Note: To keep your Lambswool Duster free of dust and allergens, we recommend periodic cleaning of your Lambswool Duster in the Vacuum Chamber, even if dust isn't visible on the Lambswool Duster.

To clean your Lambswool Duster in the Vacuum Chamber, simply follow these steps:

- a. Press and hold the unit's on/off switch to start the suction action. (see figure 4)
- b. **Insert the lambswool duster into the vacuum chamber and slowly move the duster in an up and down twisting motion several times. (see Figure 5)**
- c. The combination of the Dust Agitation/Suction Vents with the up and down twisting motion will most effectively remove dust from the Lambswool Duster. Hold the on/off switch to maintain the suction. Release to turn the unit off.

During the above cleaning cycle, dust and allergens are being suctioned away and captured in the Dust Drawer's Stainless Steel Pre-Filter Screen and the HEPA Filter (see figure 6). Only clean, allergen free air is recirculated into your home.

Your Lambswool Duster is now clean and ready to dust another room in your house.

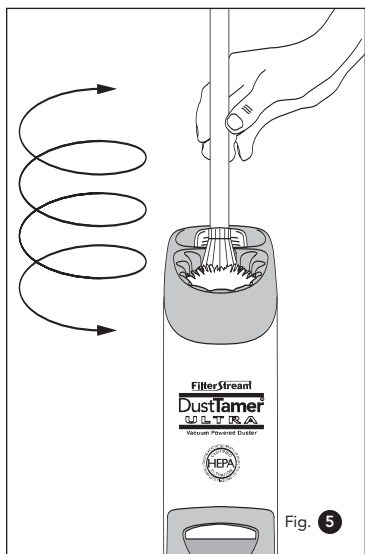
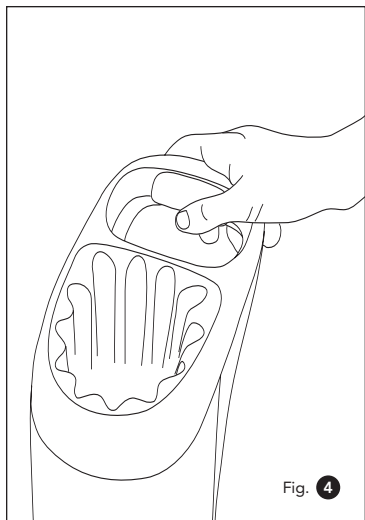

LAMBSWOOL DUSTER STORAGE

Your Lambswool Duster can be stored inside the Vacuum Chamber or hung from a hook, nail, etc. with the built-in hanging hook.

(See Figures 7 & 8)

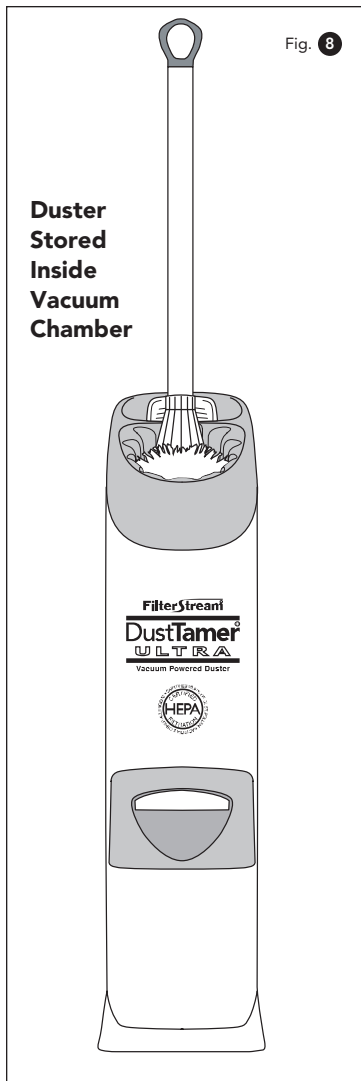
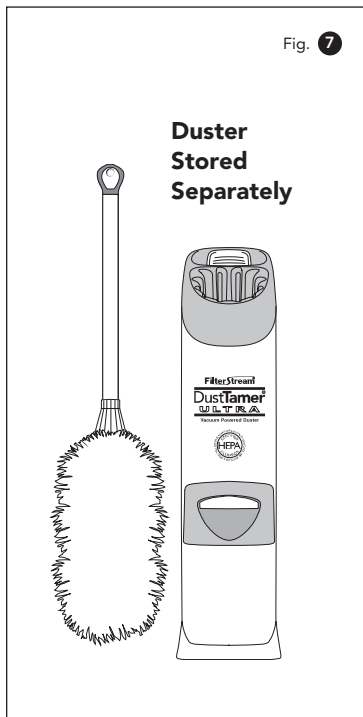

Dust, dirt and debris suctioned off by your Vacuum Chamber will collect in the Dust Drawer's Stainless Steel Pre-Filter Screen and HEPA Filter. To empty/clean these parts, please follow these steps:

1. Remove the Dust Drawer

Holding the Vacuum Chamber Housing with one hand use the other hand to pull the Dust Drawer from the unit. (see figure 9)

2. Cleaning the Dust Drawer

The Dust Drawer with Stainless Steel Pre-Filter Screen can be cleaned by emptying the dust in the trash, or preferably, in the sink under running water (see figure 10) to ensure that dust particles are not reintroduced to the household. Thoroughly dry the Dust Drawer and the Pre-Filter Screen after cleaning to prevent moisture from getting on the HEPA filter.

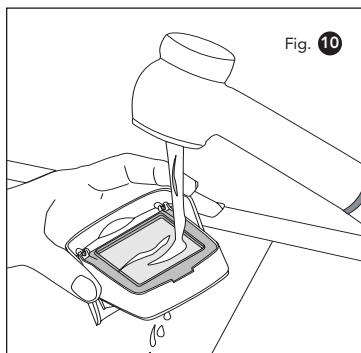

3. Cleaning HEPA Filter

To remove the HEPA Filter from the Vacuum Chamber Housing, insert your thumb and middle finger into the opening where the Dust Drawer was located and lift the HEPA filter out. Use your finger to lightly clean the paper surface of the HEPA Filter, clearing off any dirt, dust, and hair. You can also gently tap the HEPA Filter on the edge of the garbage can or sink face down for additional cleaning. (see figure 11)

Note: Do not wash the HEPA filter. Water will permanently damage the filter.

4. Cleaning Vacuum Chamber

Cleaning Interior: Remove any dust that may build up inside the Vacuum Chamber with a dry cloth.

Cleaning Exterior: Clean the Vacuum Chamber's exterior with a damp cloth

Warning: Never immerse the Vacuum Chamber in water. This may damage the electrical contacts and circuitry inside the unit.

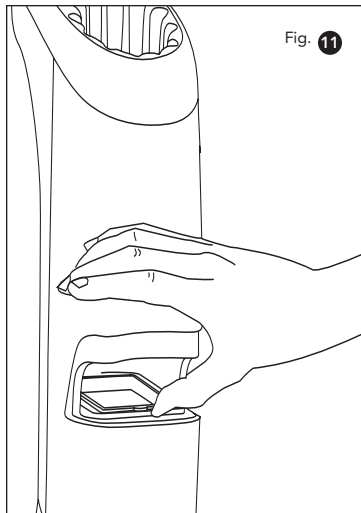

Note: Make sure that all parts are dry before putting them back together.

4. After cleaning, insert the HEPA Filter and Dust Drawer back into the Vacuum Chamber Housing. (see figure 12)
Insert the Dust Drawer into the Vacuum Chamber Housing until the Dust Drawer is securely seated in the unit. (see figure 13)

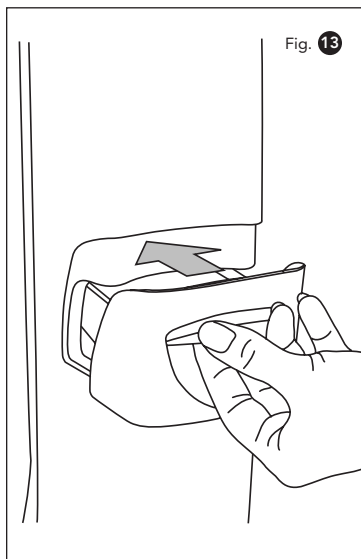
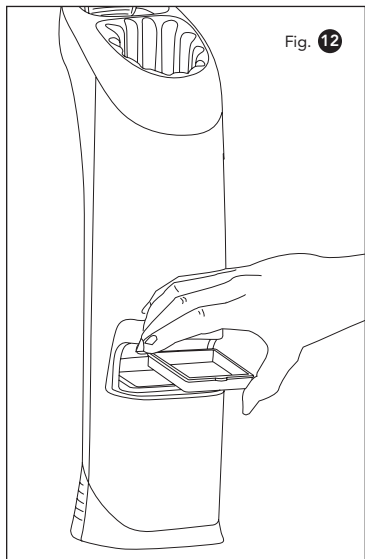

Your DustTamer Ultra® Vacuum Chamber uses 6 nickel cadmium (Ni-Cad) batteries which are factory installed in the Battery Compartment located at the bottom of the unit. When the battery life has been exceeded, the batteries should be removed from the Vacuum Chamber and recycled in accordance with state, and/or national laws.

To remove/replace the Battery Pack, follow these steps:

- a. Open the Battery Compartment by unscrewing the two screws on the bottom of the unit which hold the battery compartment door in place. (see figure 14)

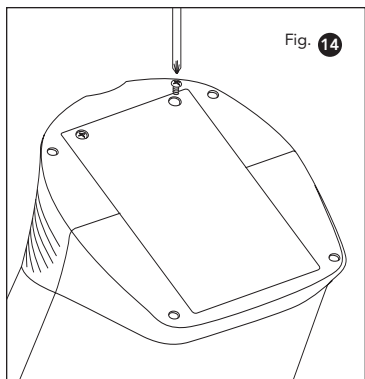

- b. The battery pack is removed and detached from the unit by unplugging the wire connectors.
- c. Attach the new battery packs' connector to the Vacuum Chamber connector and place the new pack into the Battery Compartment.
- d. Close the Battery Compartment by screwing the two screws back on the bottom of the unit.
- e. Recycle according to State, and/or National Laws. Please call 1-800-822-8837 for disposal instructions and drop off locations in your area.
- f. A new battery pack, which contains fresh batteries, can be ordered from the FilterStream Customer Service Center at 800-211-9607.

Note: Please call 1-800-822-8837 for disposal instructions and drop off locations in your area. The batteries must not be incinerated or composted.



Handy Duster Accessories:

A variety of 100% Lambswool Dusters are available to make your dusting chores easier:

Standard 22" DustTamer® Duster (Model# D-100)

Extendable 31" DustTamer® Duster (Model# EX-100)

Bendable & Extendable 33" DustTamer® Duster (Model# B-100)

Mini 10" DustTamer® Duster (Model# M-100)

All of these Duster accessories are available from FilterStream at 1-800-211-9607 or by mailing the enclosed order form to FilterStream with payment.

Replacement Filters and Battery Packs:

Replacement Filters and Battery Packs are available from FilterStream at 1-800-211-9607. Please reference the following numbers:

FilterStream® HEPA Filter (Model # H-100)

[Fits all DirtTamer Cordless Hand Vacs & DustTamer Vacuum Powered Dusters]

DustTamer® Dust Drawer Containing Stainless Steel Pre-Filter (Model #DD-100)

DustTamer® Battery Pack (Model # RBP-200)

Please visit us at www.filterstream.com for more information.

TWO YEAR LIMITED WARRANTY

FilterStream Company warrants that this product is free from defects in materials or workmanship for a period on two (2) years from the date of original purchase.

If the product fails to operate in accordance with the manufacturer's specifications, simply return the product to the retail location where you purchased it (or send it postage prepaid to the address below) within two (2) years of the date of purchase. Proof of date of purchase is required.

Upon receipt, FilterStream Company will, at its option, repair or replace the product at no charge to you.

This warranty does not cover damage resulting from accident, misuse or abuse, lack of reasonable care, the affixing of any attachment not provided with the product, or loss of parts, or subjecting the product to anything but the specified voltage or batteries.

THIS WARRANTY IS IN LIEU OF ANY OTHER WARRANTY, EXPRESS OR IMPLIED. ALL IMPLIED WARRANTIES, INCLUDING ANY IMPLIED WARRANTY OF MERCHANTABILITY OR FITNESS FOR ANY PARTICULAR PURPOSE, ARE LIMITED IN DURATION TO TWO (2) YEARS FROM THE DATE OF ORIGINAL PURCHASE. IN NO EVENT WILL FILTERSTREAM COMPANY BE RESPONSIBLE FOR INCIDENTAL, CONSEQUENTIAL, OR SPECIAL DAMAGES RESULTING FROM THE USE OF THIS PRODUCT.

Some states do not allow limitation on how long an implied warranty last and/or the exclusion or limitation of incidental or consequential damages, so the above limitation may not apply to you. This warranty gives you specific rights which vary from state to state.

To speak with a FilterStream representative, please call:

1-800-685-0710

Artwork#: 03-A200-01

**FilterStream Company Service Center
P.O. Box 481, Westwood, MA, USA 02090-0481**