

# **DIXON ZTR**

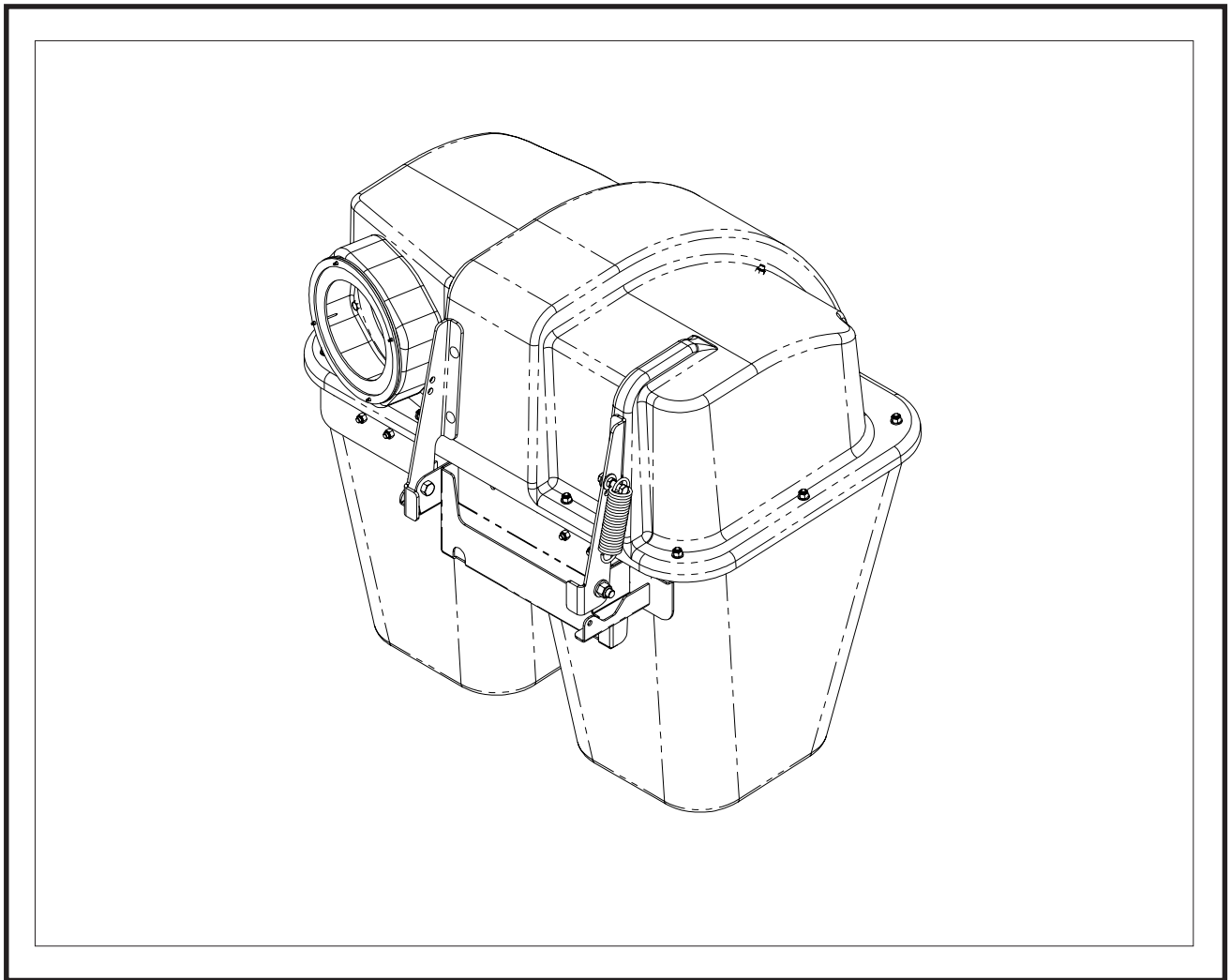

## **Collection System**

**Operators Manual**  
**Parts Manual**

**Models: 114892 - DCR2**  
**114893 - DCK2**

Please read these instructions carefully and make sure you understand them before using the machine.

MANUAL NO. 539 130678 REV. IR (02/20/07)

# SAFETY RULES



## SAFE OPERATION PRACTICES FOR RIDE-ON MOWERS



### DANGER !

THIS CUTTING MACHINE IS CAPABLE OF AMPUTATING HANDS AND FEET AND THROWING OBJECTS. FAILURE TO OBSERVE THE FOLLOWING SAFETY INSTRUCTIONS COULD RESULT IN SERIOUS INJURY OR DEATH.

### I. GENERAL OPERATION

- Read, understand and follow all instructions in the manual and on the machine before starting.
- Only allow responsible adults, who are familiar with the instructions, to operate the machine.
- Clear the area of objects such as rocks, stones, toys, wire etc., which could be picked up and thrown by the blades.
- Be sure the area is clear of all people and pets before mowing. Stop the machine if anyone enters the area.
- Never carry passengers or children even with blades off.
- Do not mow in reverse unless absolutely necessary. Always look down and behind before and while backing.
- Be aware of the mower discharge direction and do not direct it towards anyone. Do not operate the mower without either the entire grass catcher or the guard in place.
- Slow down before turning.
- Never leave a running machine unattended. Always turn off the blades, set the parking brake, stop the engine and remove the key before leaving the machine.
- Turn off blades when not mowing.
- Stop engine before removing grass catcher or unclogging chute.
- Mow only in daylight or good artificial light.
- Do not operate the machine while under the influence of alcohol or drugs.
- Watch out for traffic when operating near or crossing roadways.
- Use extra care when loading and unloading the machine onto a trailer or truck.
- Data indicates that operators, age 60 years and above, are involved in a large percentage of riding mower-related injuries. These

operators should evaluate their ability to operate the riding mower safely enough to protect themselves and others from serious injury.

- Keep machine free of grass, leaves or other debris buildup that can touch hot exhaust/engine parts and burn. Do not allow the mower deck to plow leaves or other debris that can cause buildup to occur. Clean any oil or fuel spillage before operating or storing the machine. Allow machine to cool before storage.

### II. SLOPE OPERATION

Slopes are a major factor related to loss-of-control and tip-over accidents, which can result in severe injury or death. All slopes require extra caution. If you cannot back up the slope or if you feel uneasy on it, do not mow it.

#### DO:

- Mow up and down slopes (10° Max.), not across.
- Remove obstacles such as rocks, tree limbs, etc.
- Watch for holes, ruts, or bumps. Uneven terrain could overturn the machine. **Tall grass can hide obstacles.**
- Use slow speed. Choose a low speed so that you will not have to stop while on the slope.
- Use extra care with grass catchers or other attachments. These can change the stability of the machine.
- Keep all movement on the slopes **slow** and **gradual**. Do not make sudden changes in speed or direction.
- Avoid starting or stopping on a slope. If tires lose traction, disengage the blades and proceed slowly **straight** down the slope.

# SAFETY RULES



## SAFE OPERATION PRACTICES FOR RIDE-ON MOWERS



### DO NOT:

- **Do not** turn on slopes unless necessary, and then, turn slowly and gradually downhill, if possible.
- **Do not** mow near drop-off, ditches, or embankments. The mower could suddenly turn over if a wheel is over the edge of a cliff or ditch, or if an edge caves in.
- **Do not** mow on wet grass. Reduced traction could cause sliding.
- **Do not** try to stabilize the machine by putting your foot on the ground.
- **Do not** use grass catcher on steep slopes.

### III. CHILDREN

Tragic accidents can occur if the operator is not alert to the presence of children. Children are often attracted to the machine and the mowing activity. **Never** assume that children will remain where you last saw them.

- **NEVER allow children to operate the machine.**
- Keep children out of the mowing area and under the watchful care of another responsible adult.
- Be alert and turn off the machine if children enter the area.
- Before and when backing, look behind and **down** for small children.
- Never carry children. They may fall off and be seriously injured or interfere with safe machine operation.
- Use extra care when approaching blind corners, shrubs, trees, or other objects that may obscure vision.

### IV. SERVICE

- The operation of any mower can result in foreign objects thrown into the eyes, which can result in severe eye damage. Always wear safety glasses or eye shields while operating your mower or performing any adjustments or repairs. We recommend a wide vision safety mask over spectacles or standard safety glasses.
- Use extra care in handling gasoline and other fuels. They are flammable and vapors are explosive.
  - Use only an approved container.
  - Never remove gas cap or add fuel with the engine running. Allow engine to cool before refueling. Do not smoke.
  - Never refuel the machine indoors.
  - Never store the machine or fuel container inside where there is an open flame, such as a water heater.
- Never run a machine inside a closed area.
- Keep nuts and bolts, especially blade attachment bolts, tight and keep equipment in good condition.
- Never tamper with safety devices. Check their proper operation regularly.
- Keep machine free of grass, leaves, or other debris buildup. Clean oil or fuel spillage. Allow machine to cool before storing.
- Stop and inspect the equipment if you strike an object. Repair, if necessary, before restarting.
- Never make adjustments or repairs with the engine running.
- Grass catcher components are subject to wear, damage, and deterioration, which could expose moving parts or allow objects to be thrown. Frequently check components and replace with manufacturer's recommended parts, when necessary.
- Mower blades are sharp and can cut. Wrap the blade(s) or wear gloves, and use extra caution when servicing them.
- Check brake operation frequently. Adjust and service as shown in the Operator's manual.

# SAFETY RULES



## SAFE OPERATION PRACTICES FOR RIDE-ON MOWERS



- **NEVER allow children to operate the machine.**
- Be sure the area is clear of other people before mowing. Stop machine if anyone enters the area.
- Never carry passengers or children even with the blades off.
- Do not drive in reverse unless absolutely necessary. Always look down and behind before and while backing.
- Never carry children. They may fall off and be seriously injured or interfere with safe machine operation.
- Keep children out of the mowing area and under the watchful care of another responsible adult.
- Be alert and turn machine off if children enter the area.
- Before and when backing, look behind and down for small children.
- Mow up and down slopes (10° Max), not across.
- Remove obstacles such as rocks, tree limbs, etc.
- Watch for holes, ruts, or bumps. Uneven terrain could overturn the machine. Tall grass can hide obstacles.
- Use a slow speed while on slope or hill.
- Avoid starting or stopping on a slope. If tires lose traction, disengage the blades and proceed slowly straight down the slope.
- If machine stops while going uphill, disengage blades, shift into reverse and back down slowly.
- Do not turn on slopes unless necessary, and then, turn slowly and gradually downhill, if possible.



### CAUTION

Look for this symbol to point out important safety precautions. It means **CAUTION! BECOME ALERT! YOUR SAFETY IS INVOLVED.**



### CAUTION

In order to prevent accidental starting when setting up, transporting, adjusting or making repairs, always disconnect spark plug wire and place wire where it cannot contact spark plug.



### WARNING

**DO NOT tow any trailers, etc. with this mower. They may jackknife or over turn causing damage to the mower and possibly serious injury to the operator.**



### WARNING

Engine exhaust, some of its constituents, and certain vehicle components contain or emit chemicals known to the State of California to cause cancer and birth defects or other reproductive harm.



### WARNING

Battery posts, terminals and related accessories contain lead and lead compounds, chemicals known to the State of California to cause cancer and birth defects or other reproductive harm. Wash hands after handling.

**CONGRATULATIONS** on your purchase of a new Grass Catcher. It has been designed, engineered and manufactured to give you the best possible dependability and performance.

Should you experience any problem you cannot easily remedy, please contact your nearest authorized service center/ department. They have competent, well-trained technicians and the proper tools to service or repair this mower.

Please read and retain this manual. The instructions will enable you to assemble and maintain your Grass Catcher properly. Always observe the "SAFETY RULES".

**NOTE:** To make debris disposal easier 30 gallon (3.0 mil) plastic trash bags may be inserted in plastic grass containers.

## KNOW YOUR GRASS CATCHER

READ THIS OPERATION MANUAL AND SAFETY RULES BEFORE ASSEMBLING OR OPERATING YOUR GRASS CATCHER. Compare the illustrations with the carton contents to familiarize yourself with the parts before starting the assembly. Study the operating instructions and safety precautions thoroughly to insure proper functioning of your Grass Catcher and to prevent injury to yourself and others. Save this manual for future reference.



### WARNING

The operation of any mower can result in foreign objects thrown into the eyes, which can result in severe eye damage. **ALWAYS wear safety glasses or eye shields before starting your mower and while mowing. We recommend a wide vision safety mask for over the spectacles or standard safety glasses.**

---

## TABLE OF CONTENTS

---

SAFETY RULES .....	2-4	PARTS .....	13
CARTON CONTENTS .....	6	HOOD ASSEMBLY .....	14
ASSEMBLY .....	7 - 10	BAGGER ASSEMBLY .....	16
OPERATION .....	11	GRASS BAG .....	17
CUSTOMER RESPONSIBILITIES .....	12	MOUNT KIT RAM .....	18
STORAGE .....	12	MOUNT KIT KODIAK .....	19
		WEIGHT KIT RAM .....	20
		WEIGHT KIT KODIAK .....	21

## UNPACKING INSTRUCTIONS

- Remove all parts and packing materials from carton.
- Check carton contents against list. Be sure all parts are there.

## CARTON CONTENTS:

- |                       |                    |
|-----------------------|--------------------|
| 2 - Container Tops    | 1 - Cover Assembly |
| 2 - Container Bottoms | 1 - Bag of Parts   |
| 1 - Upper Chute       | 1 - Owner's Manual |
| 1 - Lower Chute       |                    |
| 2 - High Lift Blades  |                    |

## TOOLS REQUIRED FOR ASSEMBLY

- (1) 1/2" Wrenches
- (1) 5/8" Socket
- Ft/Lbs Torque Wrench

## PARTS IDENTIFICATION

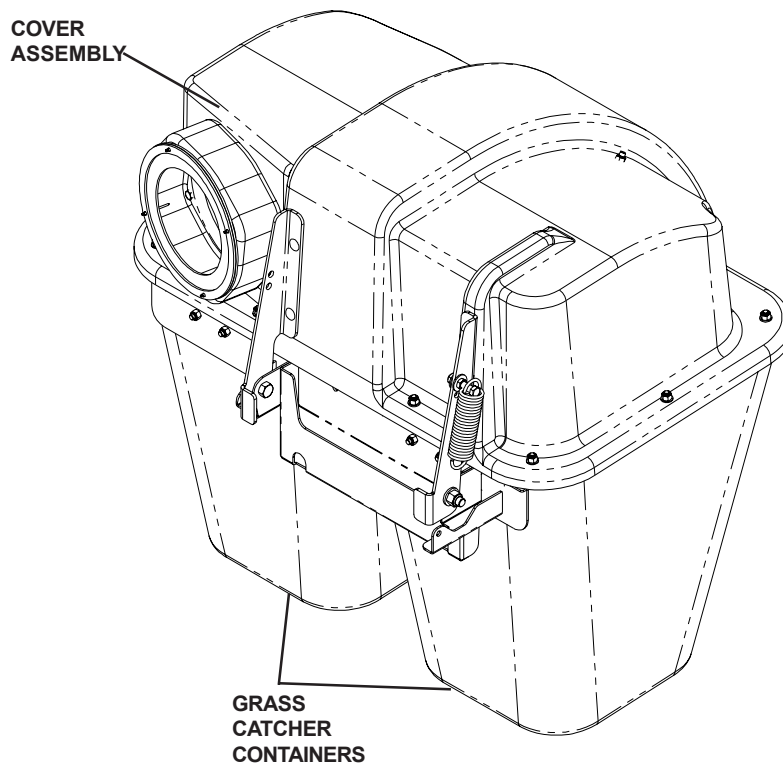

**NOTE:** When right hand (R.H.) and left hand (L.H.) are mentioned in this manual, it means when you are seated on the mower in the operator's position.



### CAUTION

#### BEFORE ASSEMBLING GRASS CATCHER TO MOWER:

- Set parking brake.
- Place motion control levers in "NEUTRAL " position.
- Turn ignition key "OFF" and remove key.
- Make sure the blades and all moving parts have completely stopped.
- Disconnect spark plug and place wire where it cannot come in contact with plug.

# ASSEMBLY

## 1 COLLECTION MOUNT BRACKETS (See Figure 1.)

### RAM

1. To prevent damage to grass bags, remove hitch from rear of chassis. Instead of removing the hitch, you may prefer to mount it backward (pointing to the front). If mower has just been uncrated, the hitch should already be mounted backward.
2. Attach bagger mount plate to rear of engine guard. Use four 5-16-18 x 3/4" carriage bolts and four 5/16-18" nyloc nuts. Refer to illustration.
3. Attach a bagger strap to side hole in bagger mount plate. Use 3/8-16 x 1" carriage bolt, 3/8" washer and 3/8-16" nyloc nut. Attach other end of bagger brace to top front hole in engine guard, using existing frame hardware. Refer to Figure 1. Repeat for other side of machine.

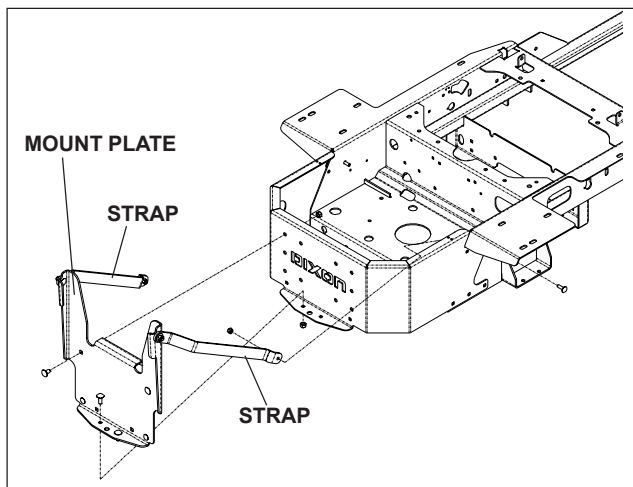
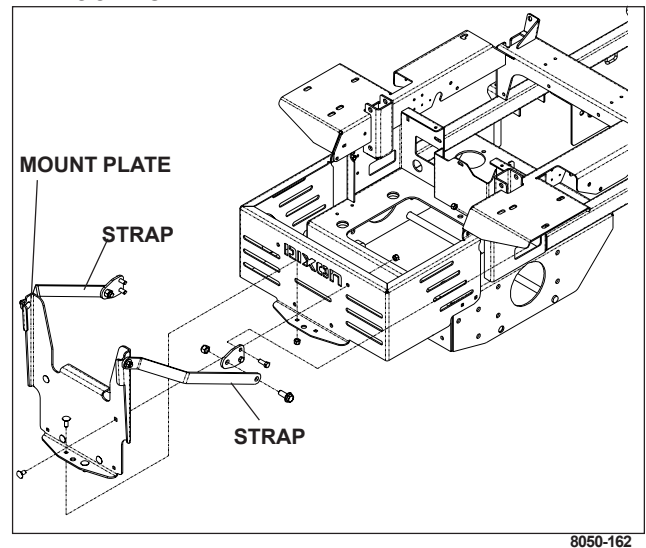

FIGURE 1

8050-161

### KODIAK

1. To prevent damage to grass bags, remove hitch from rear of chassis. Instead of removing the hitch, you may prefer to mount it backward (pointing to the front). If mower has just been uncrated, the hitch should already be mounted backward.
2. Attach bagger mount plate to rear of engine guard. Use four 3/8-16 x 3/4" carriage bolts and four 3/8" nyloc nuts. Refer to illustration.
3. Attach a bagger strap to side hole in bagger mount plate. Use 3/8-16 x 1" carriage bolt, 3/8" washer and 3/8-16" nyloc nut. Attach other end of bagger brace to top front hole in engine guard, using existing frame hardware. Refer to Figure 2. Repeat for other side of machine.



8050-162

FIGURE 2

4. For both Ram and Kodiak, slide bagger support down into bagger mount plate.

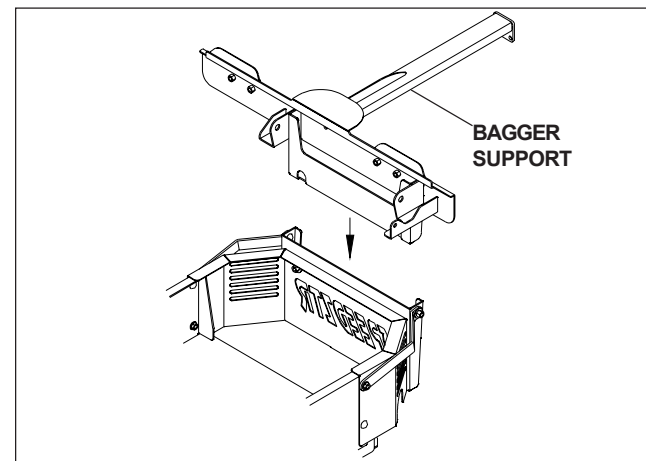

8050-163

FIGURE 3



# ASSEMBLY

## 2 MOUNTING COVER ASSEMBLY TO SUPPORT ASSEMBLY (See Figure 4)

**NOTE:** For ease of assembly, you may wish to obtain the assistance of another person for mounting cover assembly to mower.

1. Install catcher top to left side of bagger support, as illustrated. Use a 1/2-13 x 1-1/4" bolt, one 1/2" washer, a spacer and a 1/2" nyloc nut. The spacer fits inside hole in bracket. Repeat for other side. Catcher top pivots on these bolts.
2. Install a tension spring to left side of the assembly. Refer to illustration for location of spring bolt and spring hole to attach spring. This spring will raise the catcher top when the latch is released, making it easier to empty the bags.
3. Install grass bags in catcher. The cutout portion at the top of the bags goes toward the front of the machine. The illustrated bag retaining clip slides between the fabric and the tube.
4. Close catcher top. Adjust the rear latch to the desired location and tighten hardware.

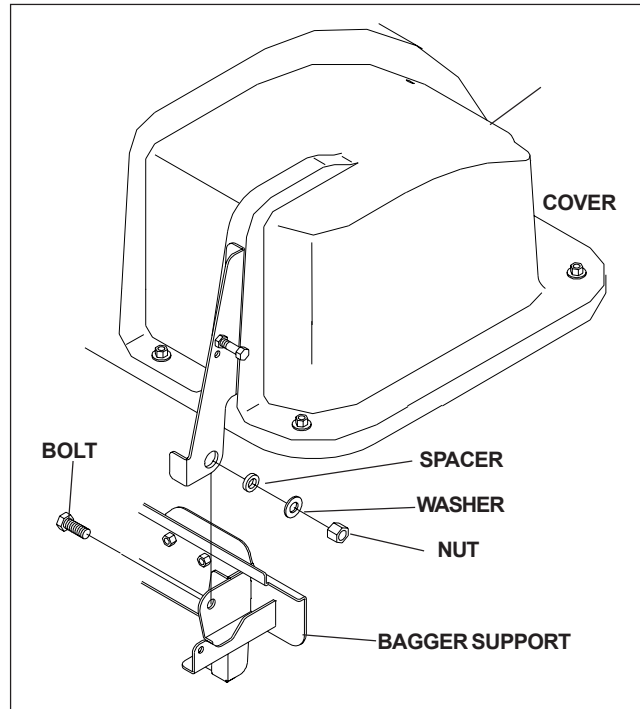

FIGURE 4

## 3 BLADE REPLACEMENT

Tools Needed:

- 9/16" Socket and Ratchet
- Ft/Lbs Torque Wrench

The mower comes from the factory with a low lift blade. The blades need to be replaced with the high lift blades provided in kit. Failure to do this may result in poor performance of the collection system.

1. Lift up the front of the mower and secure with jack stands.
2. Using a 9/16" socket and ratchet, remove the blade bolts and blades.
3. Reinstall the new high lift blades and bolts.
4. Torque the blade bolts to 35 ft/lbs.

## 4 LEVEL MOWER DECK

Be sure deck is properly leveled for best mower performance. See your mower operator's manual for instructions.



# ASSEMBLY

## 5 FRONT WEIGHTS - RAM

1. Bolt cast weight and two weight brackets together using four bolts (539 106492, 3/8 x 2 3/4") and four nuts (539 976979, 3/8" nyloc).
2. Slide both weight brackets over the front tube on the frame. Be sure to position in the center of the frame.
3. Secure with four bolts (539 991126, 3/8 x 3 3/4") and four nuts (539 976979, 3/8" nyloc).



**CAUTION**

**DO NOT** operate mower with grass catcher, unless the front weights are installed.

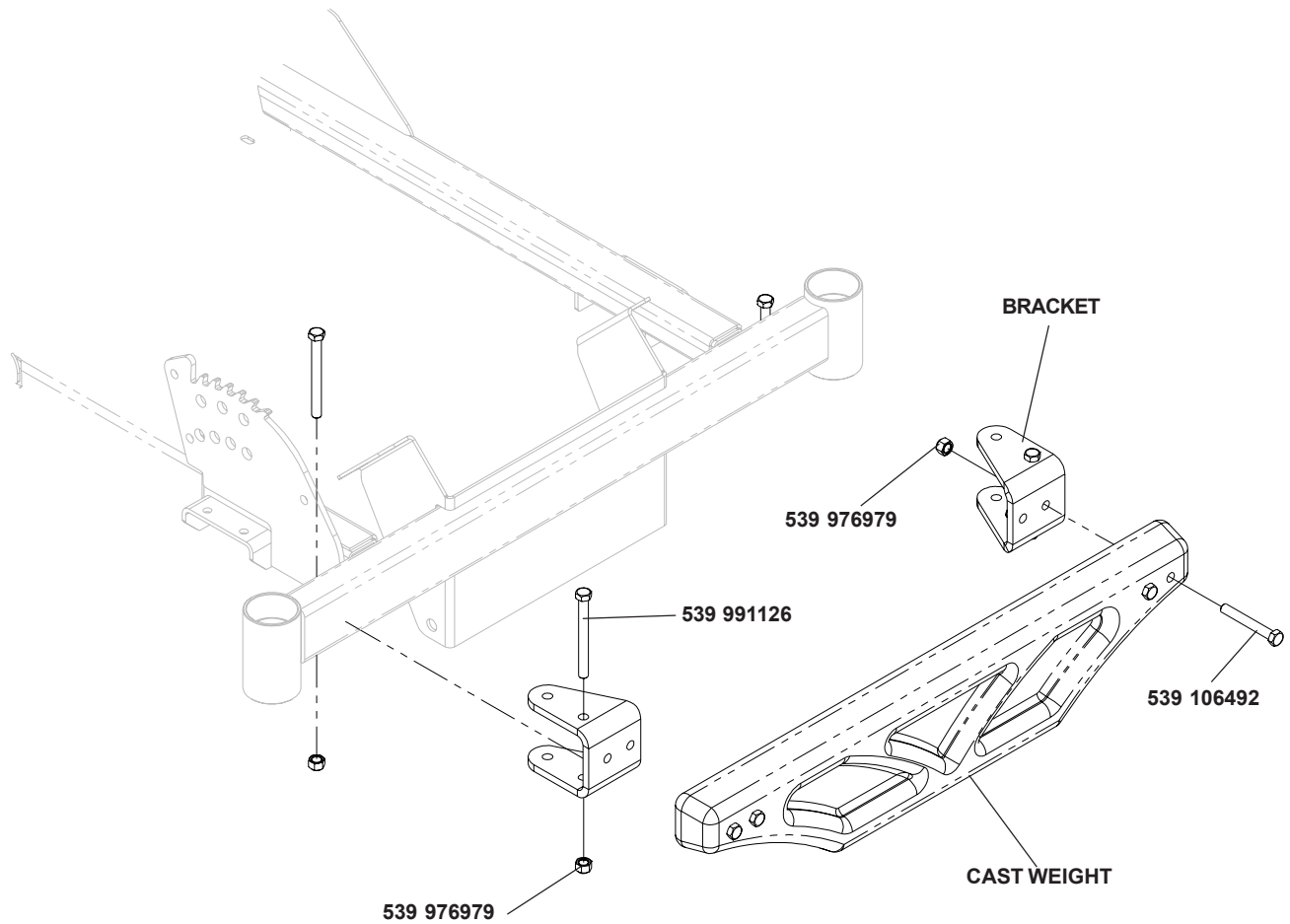

---

# ASSEMBLY

---

## FRONT WEIGHTS - KODIAK

1. Remove mower foot plate and floor pan.
2. Align weight bar to the front of the frame.  
See diagram.
3. Secure weight bar to mower frame with four 5/16-18 x 1 1/4" hex bolts from kit, reuse the four 5-16" washers and four 5/16" nyloc nuts that were removed from the foot plate.
4. Place all front weights on front weight bar.
5. Place holddown bar over front weights and secure to front weight bar using two 3/8" x 1" clevis pins and two hair pins.
6. Reinstall floor pan.

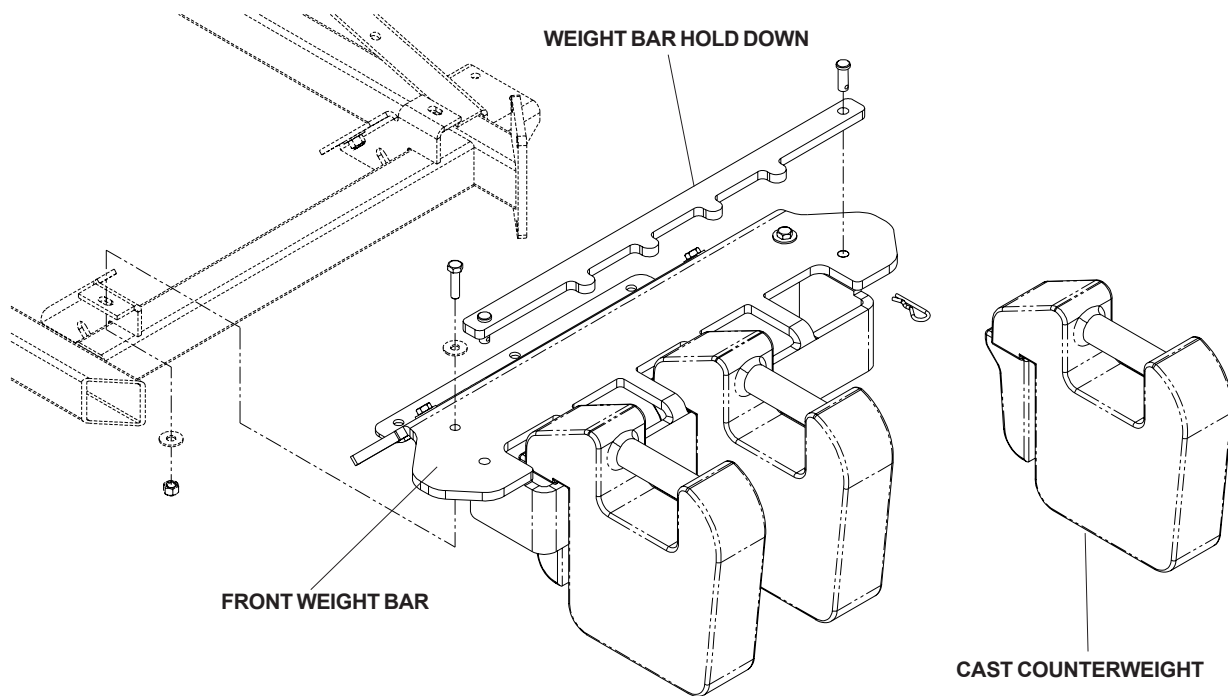

---

# OPERATION

---

## TIPS FOR IMPROVED BAGGING OPERATION:

Follow the mower operation instructions in your mower operator's manual.

When operating your grass catcher on a lawn where grass and leaf bagging equipment has not been used, you are picking up thatch and debris that has accumulated for long periods of time. The amount collected and the total time of operation may be greater than you will experience with regular use of your grass catcher.

- Always run throttle at full speed when bagging.
- Select a speed low enough to give good mower cutting performance, good quality cut and good bagging performance.

**NOTE:** It may be necessary to overlap width of cut to suit your conditions.

- If grass is extremely tall, it should be mowed twice. The first time relatively high, the second time to desired height.
- Use left hand side of mower for trimming.
- Plastic trash bags (3.0 mil, 30 gallon) can be inserted inside grass catcher containers for ease of debris disposal. To remove the plastic trash bags when full:
  - a. Disengage blades, shift into neutral, engage the parking brake and stop the engine.
  - b. Unlatch and raise cover.
  - c. Remove one container at a time by grasping container handles and pulling toward the rear, off of the tube rails.
  - d. With the container resting on the ground, close and secure the top of the plastic lawn bag.
  - e. Tip the container on its side and slide the filled bag from the container.
  - f. Install a new plastic lawn bag with the edges of the bag draped over upper lip of the container (for replacement bags refer to REPLACEMENT PARTS).
  - g. Repeat for other container.

h. Reinstall containers making sure right container overlaps left container at center supports.

i. Close cover and secure latches over center support tubes.

- Avoid cutting wet grass or mowing in the morning while the dew is still heavy. Grass clippings collected under these conditions tend to be sticky and adhere to the walls of the flow path, causing clogging.
- If the grass catcher fails to pick up cut grass or leaves, it is an indication that clogging has occurred in the system or that the grass catcher containers are full.
  - a. Disengage blades, place motion control levers in neutral position.
    - Unlatch and raise cover.
    - Slide out containers and dispose of clippings.
    - Replace containers, close cover, and latch.
  - b. Unlatch chutes and check for clogging.
    - Remove all debris in chute.
    - Reassemble and latch chutes.



## CAUTION

- **DO NOT** operate mower with grass catcher partially installed.
- **Disengage blades and stop engine before leaving mower seat to empty containers, unclog chutes, etc.**
- **Close cover before starting.**
- **Disengage mower blades when crossing driveways or gravel surfaces and other areas where thrown objects could be a hazard.**
- **DO NOT** attempt to vacuum up cans or other potentially hazardous projectiles.

---

# CUSTOMER RESPONSIBILITIES

---

## GENERAL RECOMMENDATIONS:

Always observe safety rules when performing any maintenance.

- Before each use check for loose fasteners.
- Clean unit thoroughly after each use.

## BLADE CARE:

For best results mower blades must be kept sharp. Replace bent or damaged blades.

- See BLADE CARE instructions in your mower operator's manual.

## STORAGE:

When grass catcher is to be stored for an extended period of time, clean it thoroughly, remove all dirt, grass, leaves, etc. Store in a clean, dry place.



### CAUTION

**BEFORE PERFORMING ANY MAINTENANCE, SERVICE OR ADJUSTMENTS:**

- Set parking brake.
- Place motion control levers in "NEUTRAL" position.
- Place clutch control in "DISENGAGED" position.
- Turn ignition key to "OFF" position.
- Make sure blades and all moving parts have completely stopped.
- Disconnect spark plug wire(s) from spark plug(s) and place wire where it cannot come in contact with plug.



### CAUTION

**Do not leave grass in bagger containers. Empty containers after each use and before storing. Failure to do so may result in spontaneous combustion which could develop into a fire.**



### CAUTION

**Grass catcher components are subject to wear, damage and deterioration, which could expose moving parts or allow objects to be thrown. Frequently check components and replace with manufacturer's recommended parts, when necessary.**

# **PARTS ILLUSTRATIONS**

# HOOD ASSEMBLY

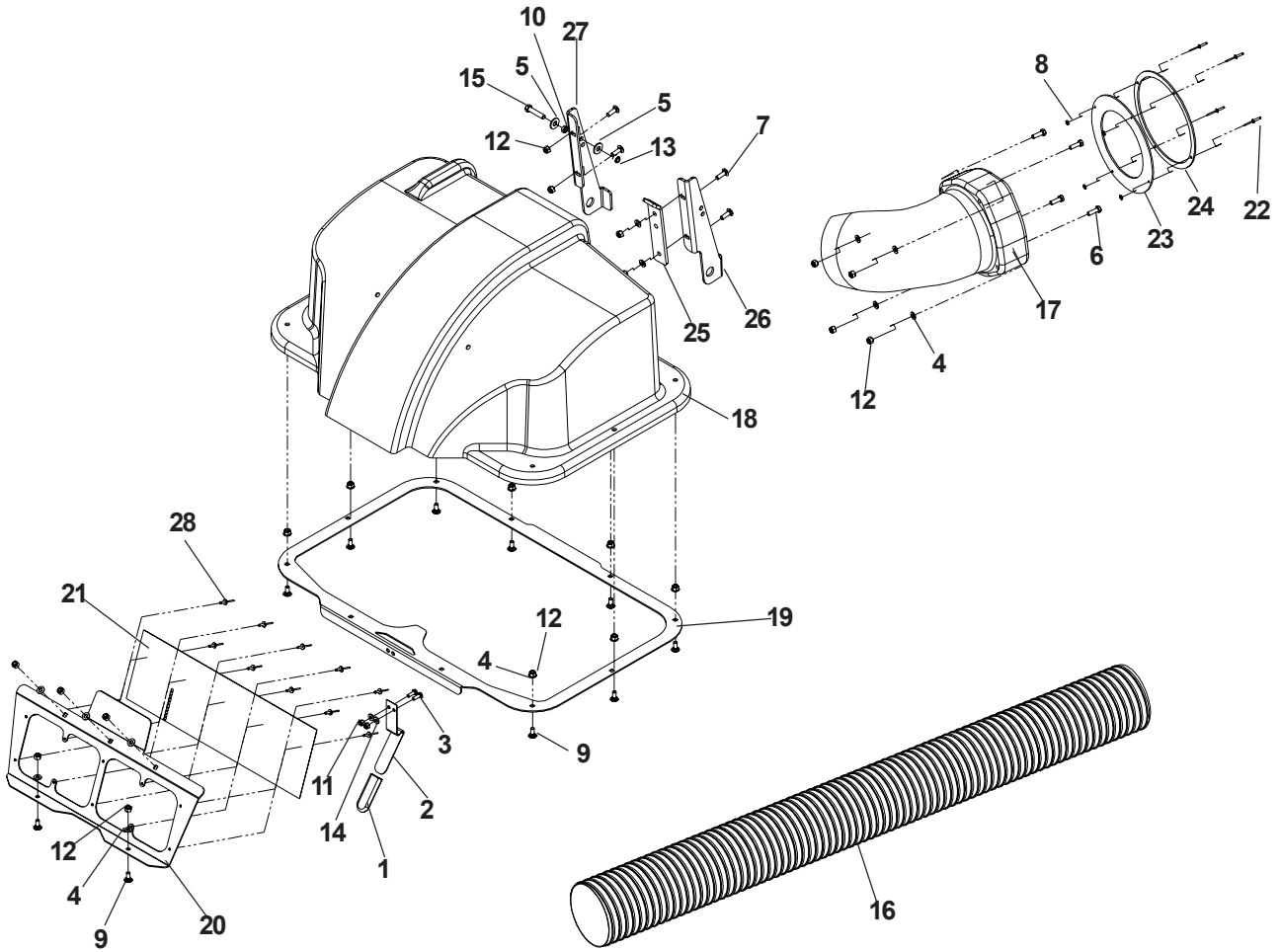

# HOOD ASSEMBLY

ITEM	PART NO.	QTY.	DESCRIPTION
1	539 115408	1	LATCH ROD GRIP
2	539 115445	1	G.C. CATCH HANDLE
3	539 990580	2	HCS, 1/4-20 X 3/4, GR5
4	539 990188	21	WASHER, 5/16, SAE
5	539 990517	2	WASHER, 3/8
6	539 990209	4	HCS, 5/16-18 X 1, GR5
7	539 107271	4	RHSNB, 5/16-18 X 1.0
8	539 115530	4	WASHER, .17
9	539 990316	13	RHSNB, 5/16-18 X 3/4, GR5
10	539 109332	1	NUT, 3/8-16, JAM
11	539 976978	2	NUT, 1/4-20, NYLOC
12	539 990717	21	NUT, 5/16-18, NYLOC
13	539 976979	1	NUT, 3/8-16, NYLOC
14	539 115562	2	WASHER, 1/4, SAE
15	539 990730	1	HCS, 3/8-16 X 1 3/4, GR5
16	539 115392	1	FLEX HOSE, 60"
17	539 117731	1	INLET TUBE
18	539 117740	1	HOOD, 2 BAGGER
19	539 117741	1	HOOD BOTTOM PLATE
20	539 117742	1	RETAINER, SCREEN
21	539 117743	1	VENT SCREEN
22	539 117820	4	POP RIVET, 5/32
23	539 117965	1	BAGGER TUBE BOOT
24	539 117966	1	BOOT BACKING PLATE
25	539 117988	1	CLAMSHELL SUPPORT PLATE
26	539 118073	1	HINGE PIVOT, RIGHT
27	539 118074	1	HINGE PIVOT, LEFT
28	539 119413	10	LARGE DOME RIVET
	539 115775	7	NYLON WIRE TIE (NOT SHOWN)



# BAGGER ASSEMBLY

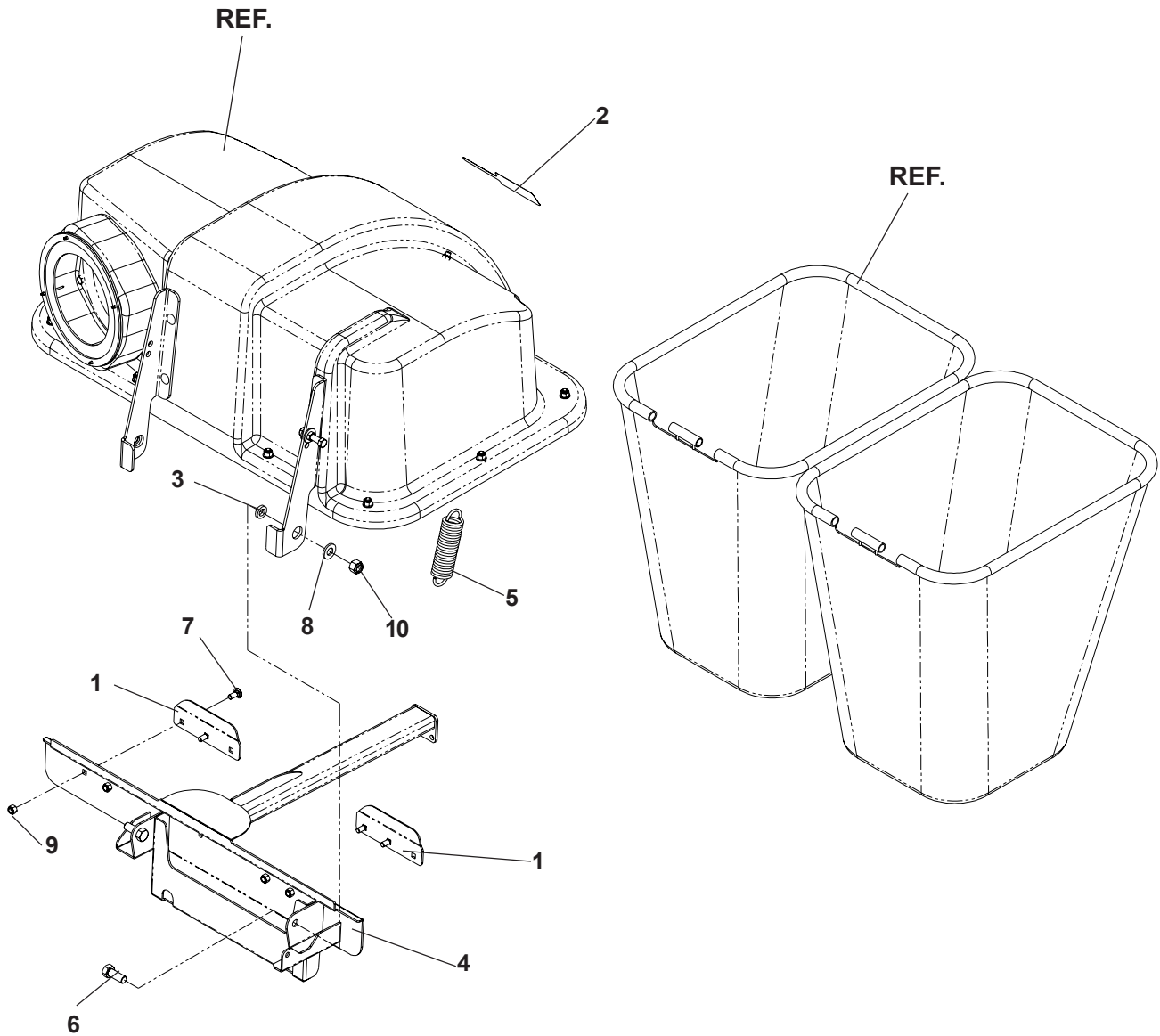

ITEM	PART NO.	QTY.	DESCRIPTION
1	539 117724	2	BAG RETAINING CLIP
2	539 117927	1	DECAL, DIXON
3	539 119012	2	SPACER
4	539 120197	1	BAGGER MOUNT
5	539 120239	1	SPRING
6	539 108369	2	HCS, 1/2-13 X 1 1/4, GR5
7	539 990316	4	RHSNB, 5/16-18 X 3/4, GR5
8	539 990250	2	WASHER, 1/2, SAE
9	539 990717	4	NUT, 5/16-18, NYLOC
10	539 101331	2	NUT, 1/2, NYLOC

# GRASS BAG ASSEMBLY

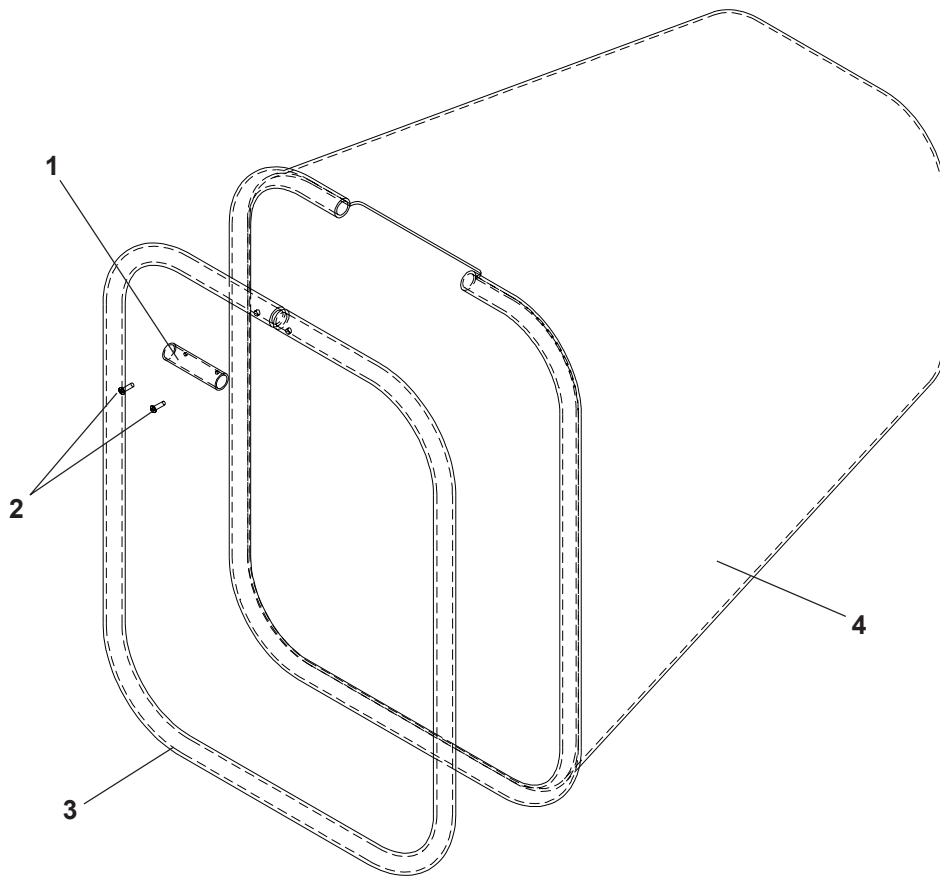

ITEM	PART NO.	QTY.	DESCRIPTION
1	539 115437	1	TUBE PLUG
2	539 115581	2	SCREW, 6-20 X 1/2 PHIL PAN D/T
3	539 117739	1	BAG TUBE, SMALL
4	539 118048	1	GRASS BAG

# MOUNT KIT - RAM

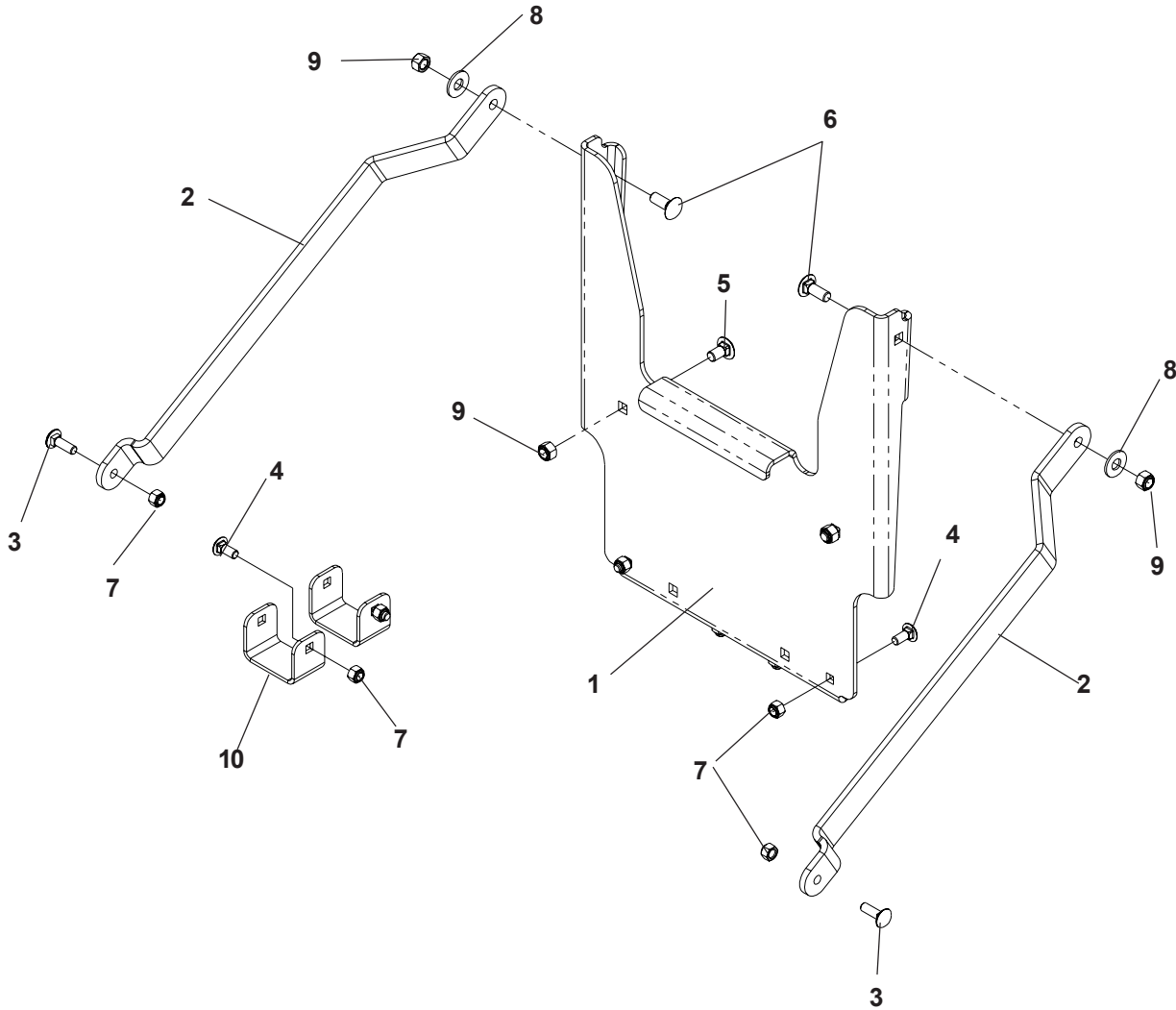

ITEM	PART NO.	QTY.	DESCRIPTION
1....	539 114851 ...	1...	PLATE, MOUNT
2....	539 114887 ...	2...	STRAP
3...	539 990208 ...	2...	RRSNB, 5/16-18 X 1, GR5
4...	539 990316 ...	4...	RHSNB, 5/16-18 X 3/4, GR5
5....	539 111785 ...	2...	RHSNB, 3/8-16 X 3/4, GR5
6...	539 990645 ...	4...	RHSNB, 3/8-16 X 1, GR5
7...	539 990717 ...	6...	NUT, 5/16-18, NYLOC
8...	539 990517 ...	2...	WASHER, 3/8
9...	539 976979 ...	6...	NUT, 3/8-16, NYLOC
10....	539 114506 ...	2...	EXTENSION, STRAP

# MOUNT KIT - KODIAK

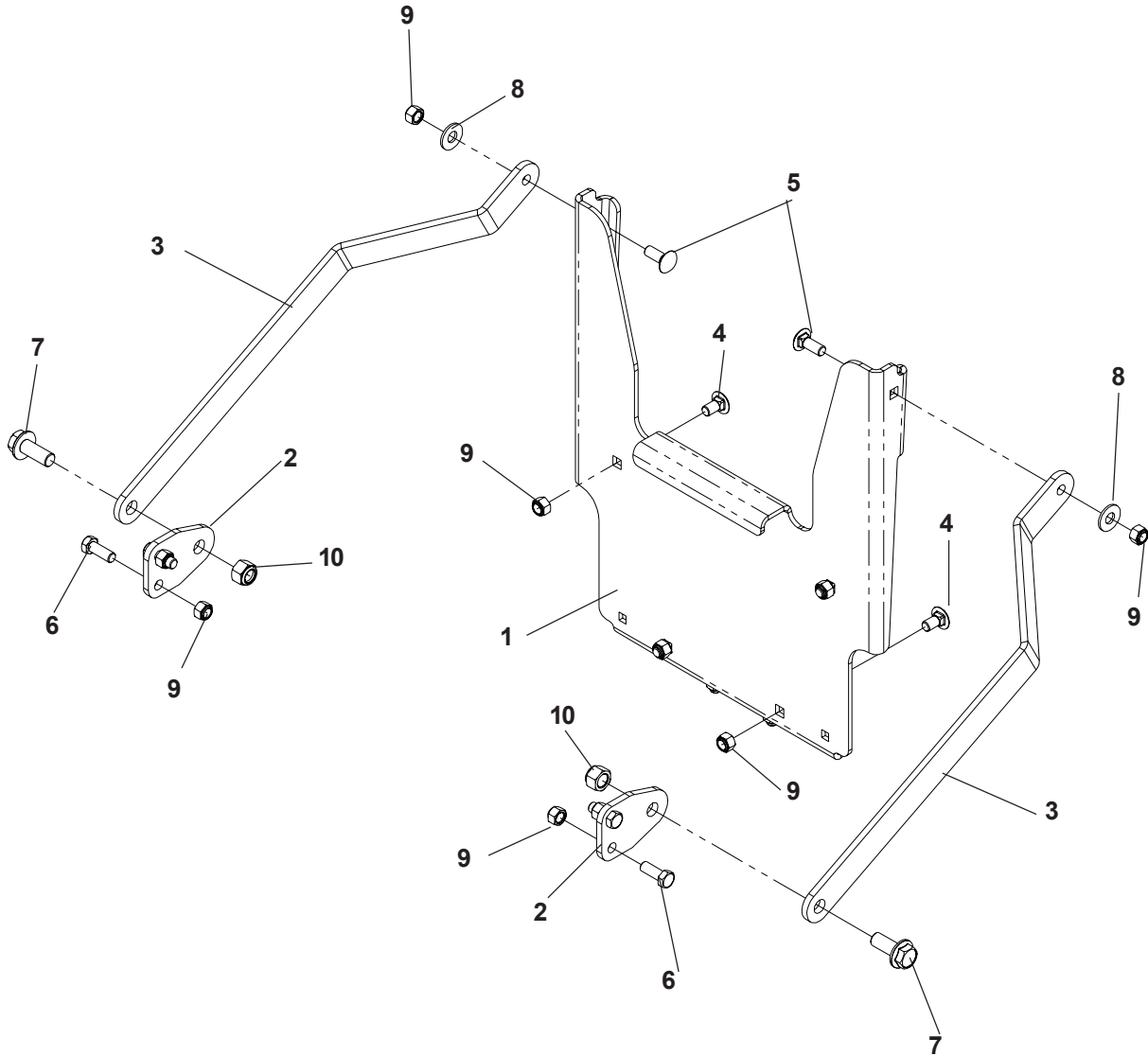

ITEM	PART NO.	QTY.	DESCRIPTION
1...	539 114851	... 1...	PLATE, MOUNT
2...	539 111215	... 2...	SUPPORT BRACKET
3...	539 114849	... 2...	STRAP
4...	539 111785	... 2...	RHSNB, 3/8-16 X 3/4, GR5
5...	539 990645	... 4...	RHSNB, 3/8-16 X 1, GR5
6...	539 990563	... 4...	HCS, 3/8-16 X 1, GR5
7...	539 990622	... 2...	BOLT, 1/2-13 X 1 1/4, WHIZLK
8...	539 990517	... 2...	WASHER, 3/8
9...	539 976979	. 12...	NUT, 3/8-16, NYLOC
10...	539 101331	... 2...	NUT, 1/2, NYLOC

# WEIGHT KIT - RAM

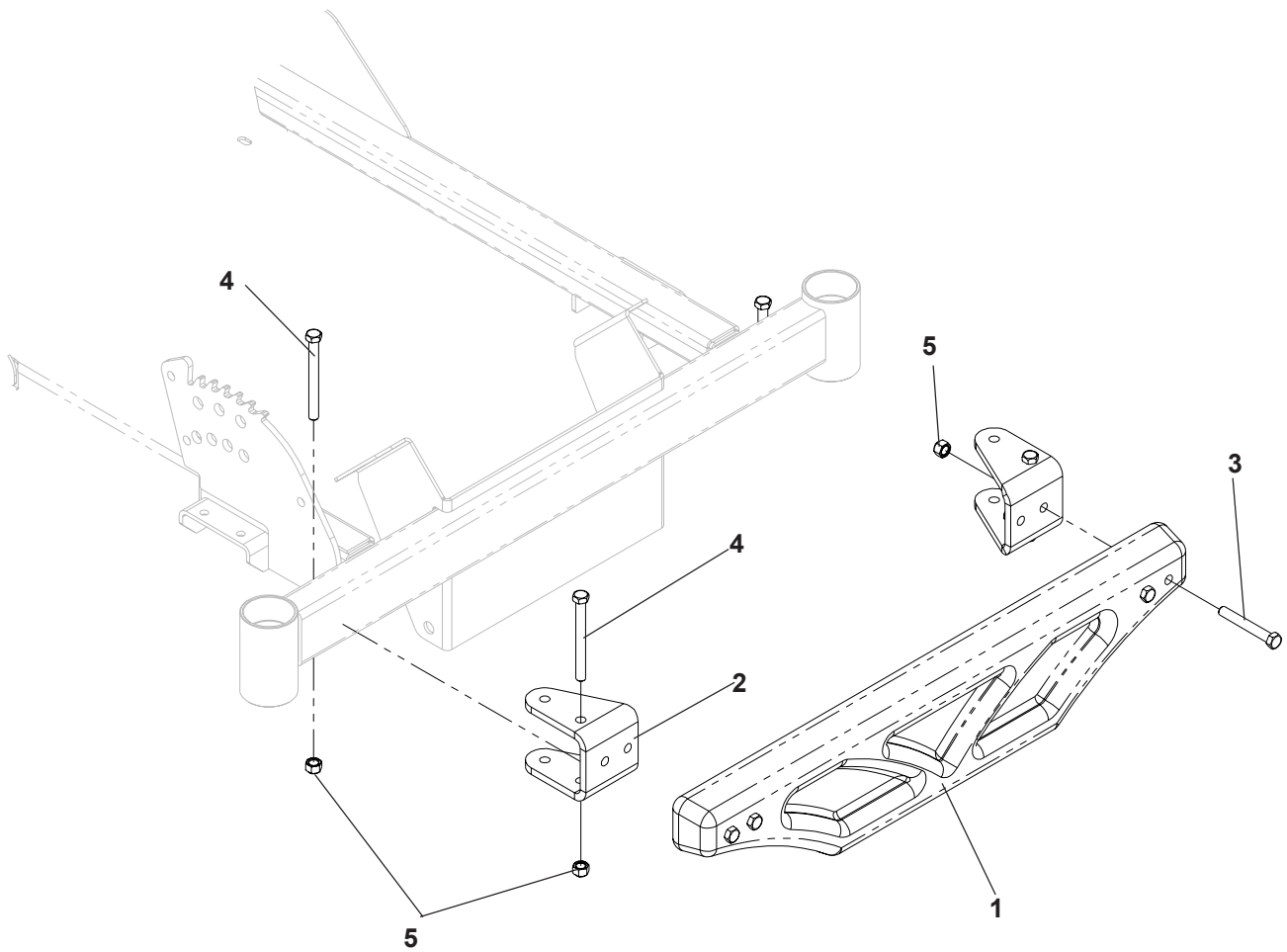

ITEM	PART NO.	QTY.	DESCRIPTION
1...	539 111587 ...	1...	CAST WEIGHT
2....	539 114898 ...	2...	BRACKET, WEIGHT
3...	539 106492 ...	4...	HCS, 3/8-16 X 2 3/4, GR5
4....	539 991126 ...	4...	HCS, 3/8-16 X 3 3/4, GR5
5...	539 976979 ...	8...	NUT, 3/8-16, NYLOC

# WEIGHT KIT - KODIAK

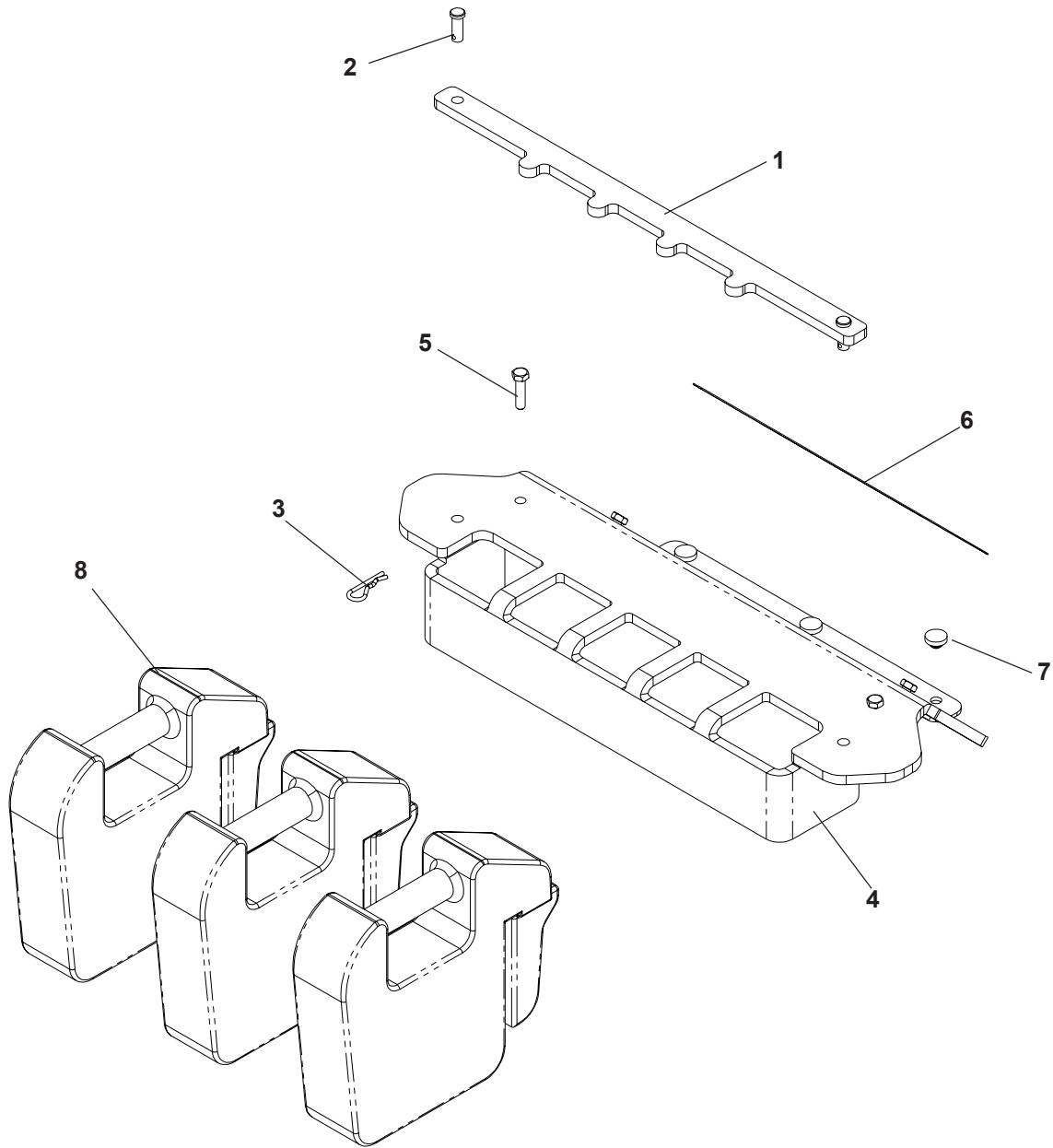

ITEM	PART NO.	QTY.	DESCRIPTION
1...	539 111313	1...	HOLD DOWN, WEIGHT BAR
2...	539 102049	2...	CLEVIS PIN
3...	539 108096	2...	SPRING RETAINER
4...	539 114858	1...	WEIGHT BAR
5...	539 990627	4...	HCS, 5/16-18 X 1 1/4, GR5
6...	539 977778	1...	ABRASIVE PAD
7...	539 102587	3...	GROMMET, BUMPER
8...	539 000019	3...	WEIGHT CAST, FRONT
	539 102115	4...	PLASTIC TIE (NOT SHOWN)







**DIXON ZTR**