

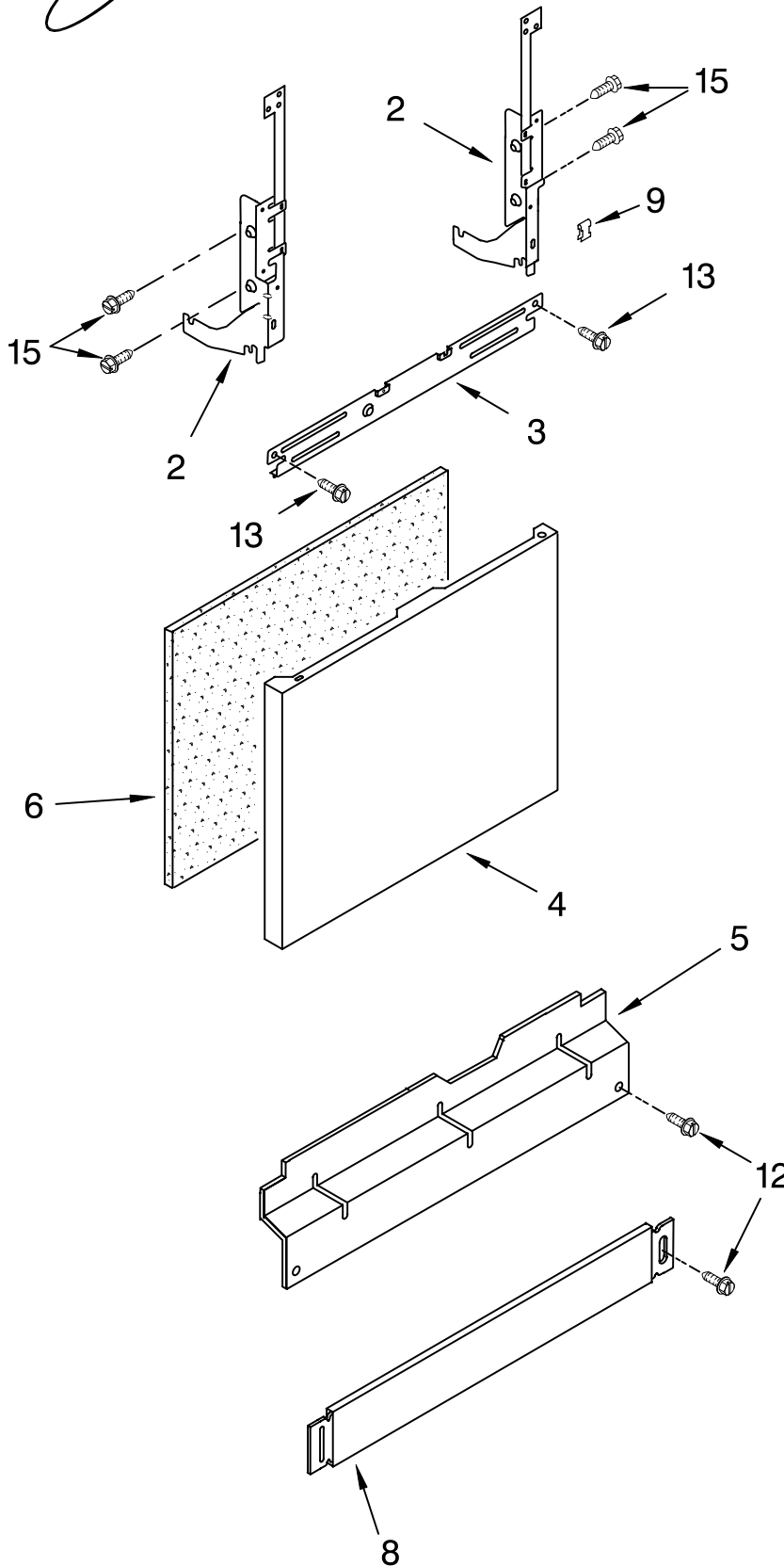

# DOOR AND PANEL PARTS

For Models: DU1100XTPB6, DU1100XTPQ6, DU1100XTPT6, DU1100XTPS6  
 (Black) (White) (Biscuit) (Stainless)

UNDERCOUNTER  
 DISHWASHER



Illus. No.	Part No.	DESCRIPTION
1	8535437	Literature Parts Instructions, Installation
	8535642	Energy Guide
	8535541	Guide, Use & Care Tech Sheet
	8535451	English/French Arm, Hinge
2	8534858	Left
	8534857	Right
3	8268983	Stiffener, Door
4		Panel Front
	8269841	Black
	8269842	White
	8269844	Biscuit
	8269845	Stainless
5		Access Panel
	8543834	Black
	8543835	White
	8543836	Biscuit
6	8268580	Insulation, Door
8		Toe Panel
	8268999	Black
	8269000	White
	8269001	Biscuit
9	8269740	Clip, Grounding
12		Screw
	302868	Black
	3400836	White
	3400865	Biscuit
13	343641	Screw
15	3369181	Screw

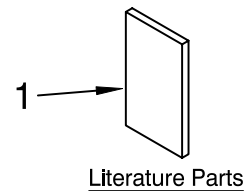

FOR ORDERING INFORMATION REFER TO PARTS PRICE LIST

# CONTROL PANEL PARTS

For Models: DU1100XTPB6, DU1100XTPQ6, DU1100XTPT6, DU1100XTPS6  
 (Black) (White) (Biscuit) (Stainless)

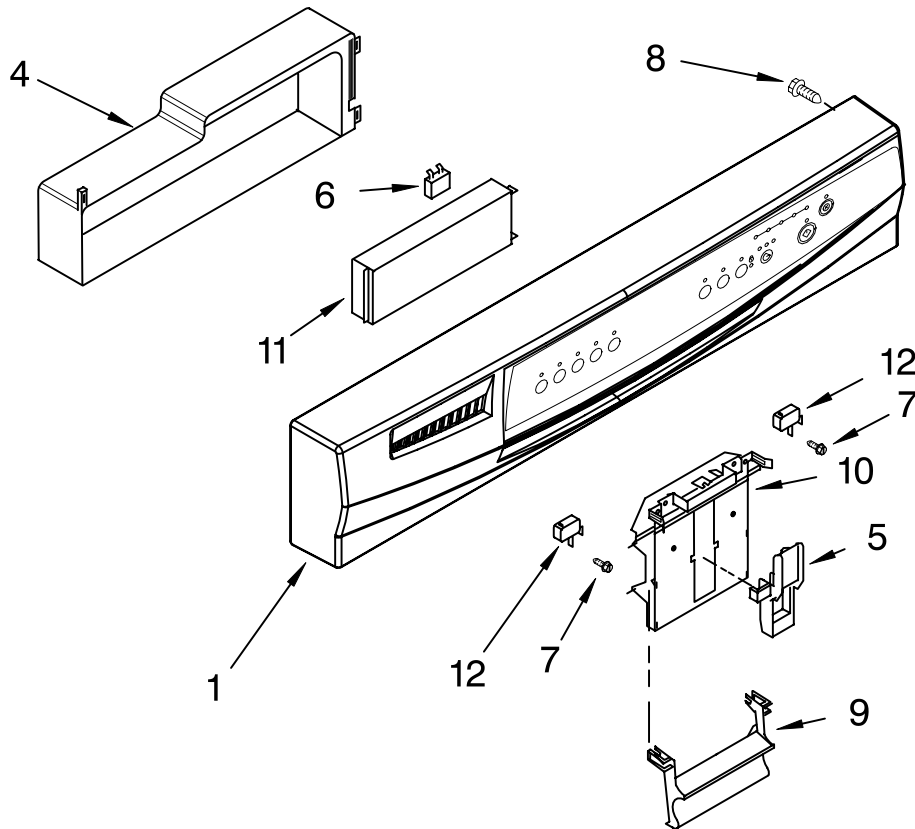

Illus. No.	Part No.	DESCRIPTION
1		Console Asm. (Includes Active Overlay & Insert)
	8573209	Black
	8573210	White
	8573211	Biscuit
4	8283512	Cover Control Shield Assembly
5	8524471	Actuator, Latch
6	8269213	Fuse, Thermal Electronic
7	3400412	Screw
8	3369051	Screw (6)
9		Handle, Latch
	8534984	Black
	8534985	White
	8534986	Biscuit
10	8524476	Bolt, Latch
11	8564544	Control, Electronic
12	8269209	Switch, Door

FOR ORDERING INFORMATION REFER TO PARTS PRICE LIST

# DOOR AND LATCH PARTS

For Models: DU1100XTPB6, DU1100XTPQ6, DU1100XTPT6, DU1100XTPS6

(Black) (White) (Biscuit) (Stainless)

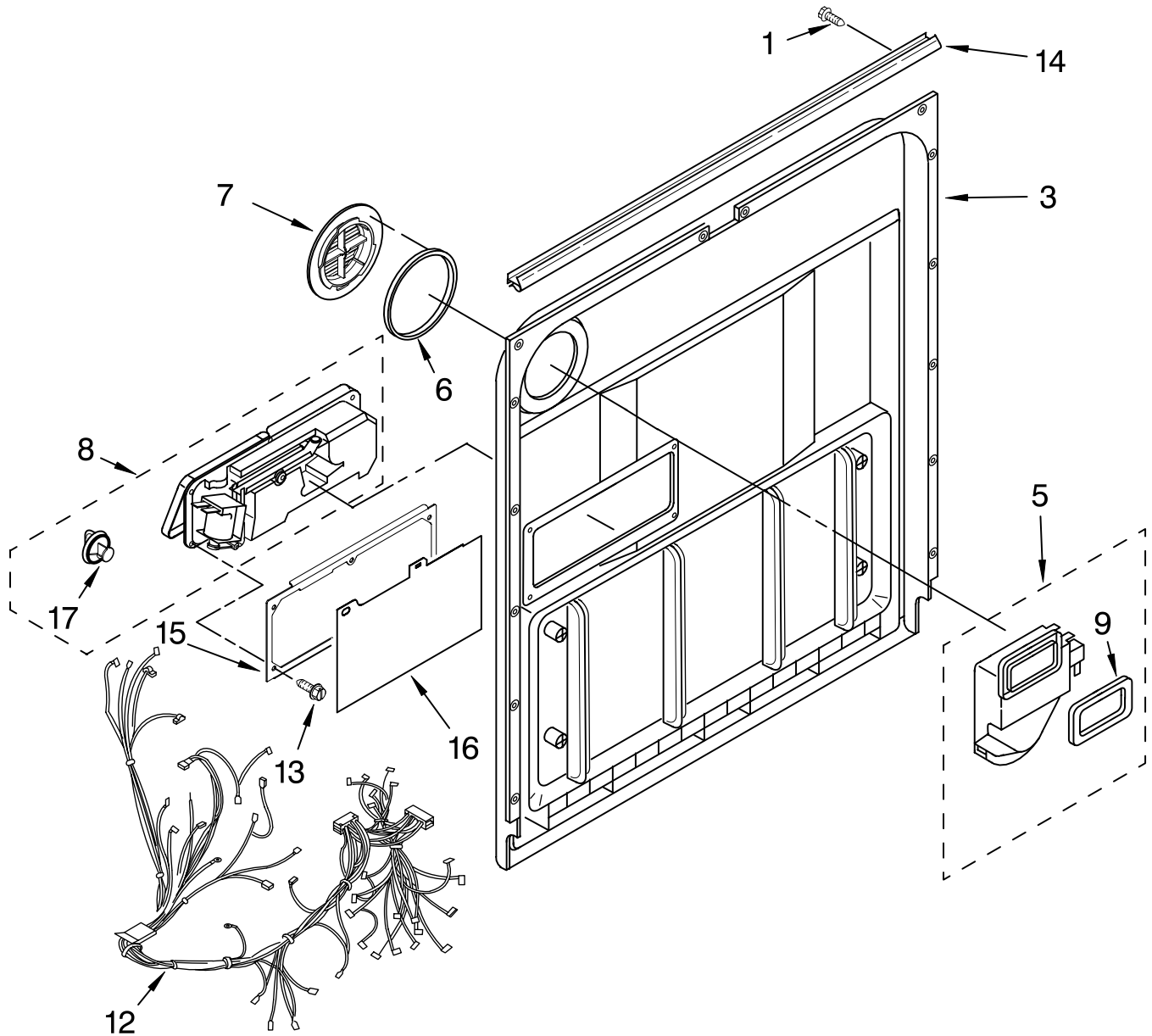

Illus. No.	Part No.	DESCRIPTION
1	3369051	Screw, Door
3	8269311	Inner Door (Also Order Item 6)
5	8542603	Vent Assembly (Also Order Item 6)
6	8269259	Gasket, Vent

Illus. No.	Part No.	DESCRIPTION
7	8542566	Deflector, Vent (Also Order Item 6)
8	8531825	Dispenser, Assembly
9	8269258	Seal, Front
12	8573180	Wiring Harness Main

Illus. No.	Part No.	DESCRIPTION
13	8281154	Screw
14	8269296	Seal, Console/door
15	8535637	Bracket, Dispenser
16	8531865	Shield, Dispenser
17	8558307	Cap, Rinse Aid

FOR ORDERING INFORMATION REFER TO PARTS PRICE LIST

# LOWER WASHARM PARTS

For Models: DU1100XTPB6, DU1100XTPQ6, DU1100XTPT6, DU1100XTPS6  
 (Black) (White) (Biscuit) (Stainless)

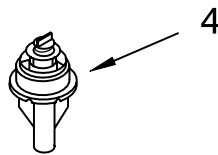
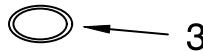
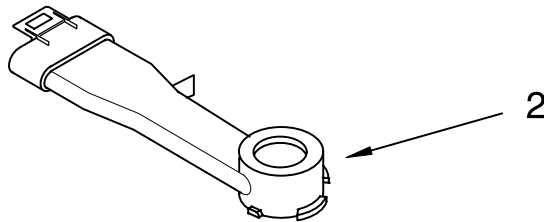
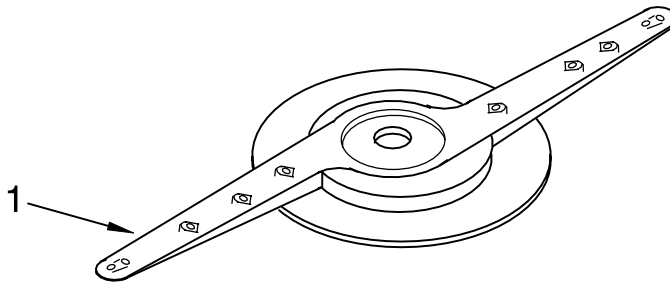

Illus. No.	Part No.	DESCRIPTION
1	8268333	Wash Arm Assembly
2	8268317	Cap, Internal Rear Feed (Also Order Item 3)
3	8268340	Seal, Sprayarm
4	8268342	Hub, Lower Sprayarm (Also Order Item 3)

FOR ORDERING INFORMATION REFER TO PARTS PRICE LIST

# HEATER PARTS

For Models: DU1100XTPB6, DU1100XTPQ6, DU1100XTPT6, DU1100XTPS6  
(Black) (White) (Biscuit) (Stainless)

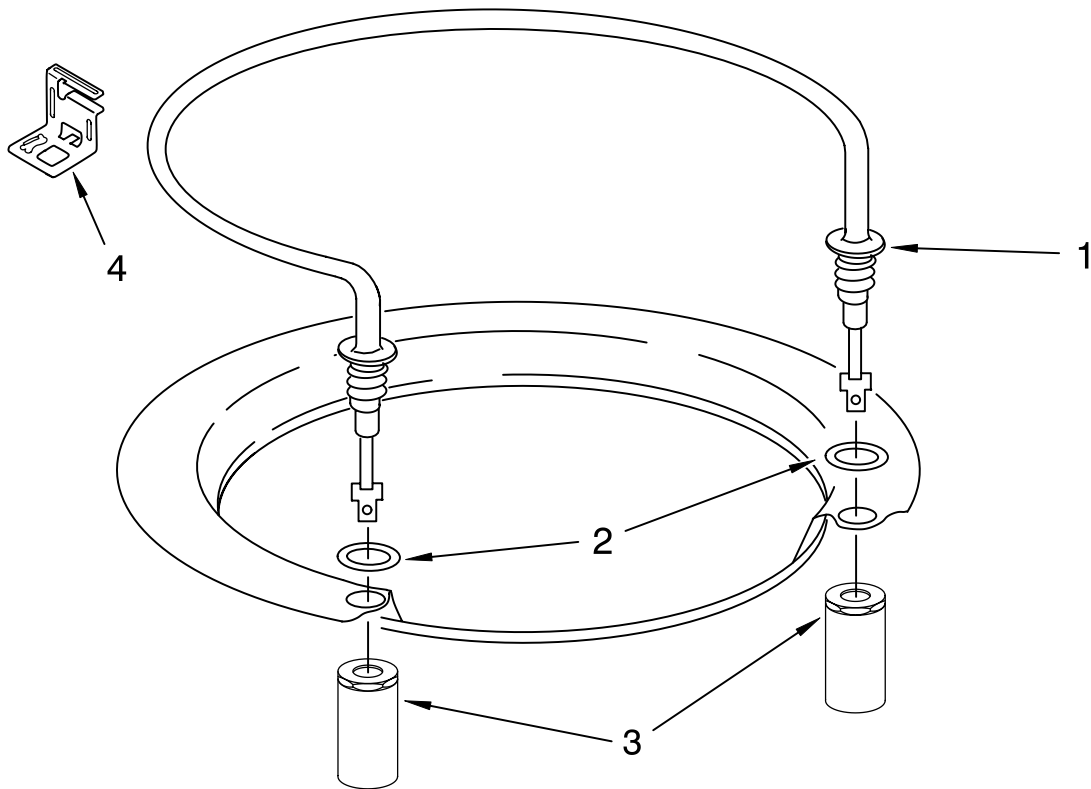

<b>Illus. No.</b>	<b>Part No.</b>	<b>DESCRIPTION</b>
1	8572861	Heater Element Assembly (Also Includes Item 2)
2	717273	Washer, Heater Element
3	8268548	Nut, Heater Element
4	8269262	Bracket, Heater Support

**NOTE:** If heater element is removed, it must be replaced.

FOR ORDERING INFORMATION REFER TO PARTS PRICE LIST

# FILL AND OVERFILL PARTS

For Models: DU1100XTPB6, DU1100XTPQ6, DU1100XTPT6, DU1100XTPS6  
 (Black) (White) (Biscuit) (Stainless)

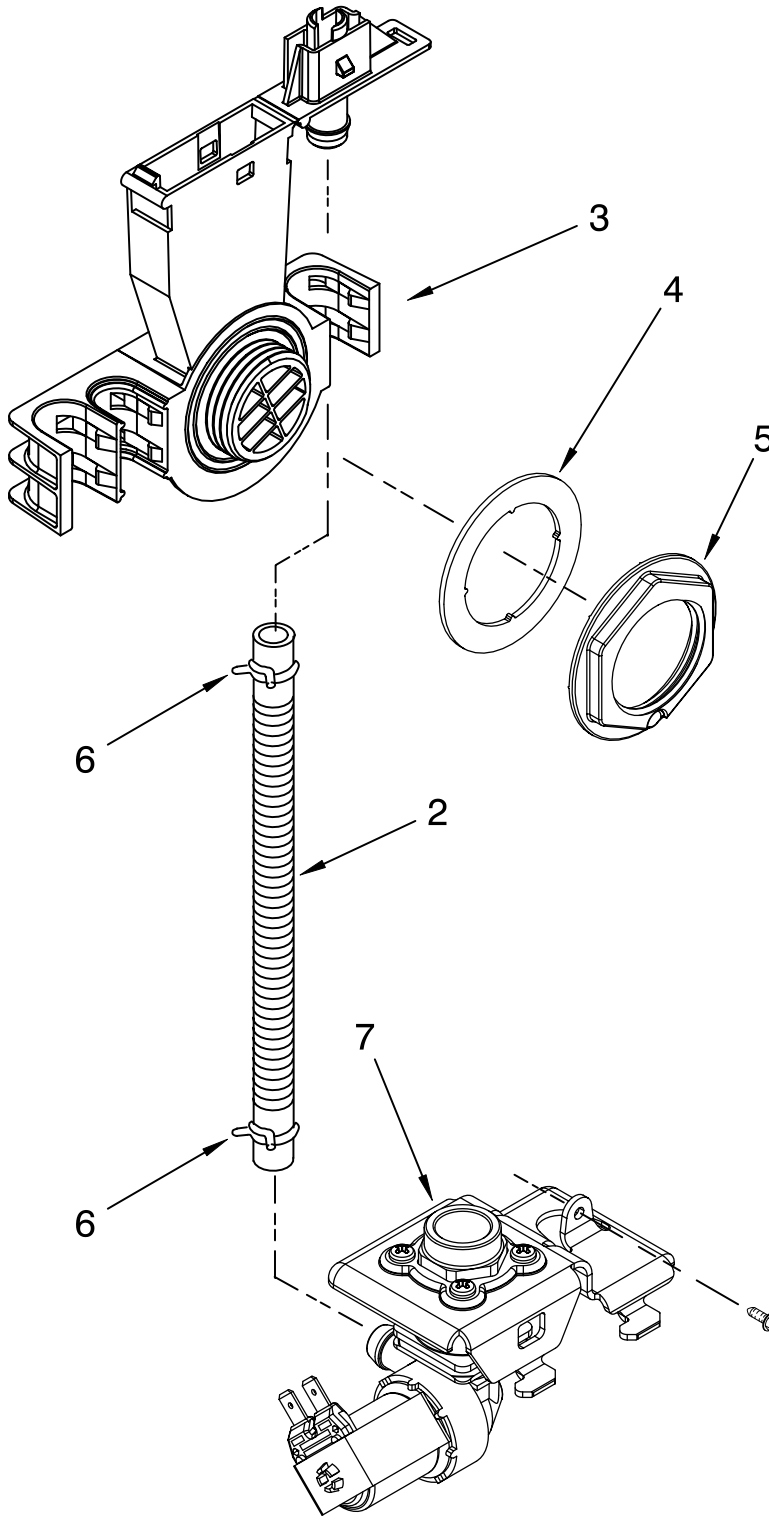

Illus. No.	Part No.	DESCRIPTION
2	8531412	Hose, Inlet
3	8531325	Water Inlet (Also Order Item 4)
4	8531323	Gasket
5	8531326	Nut, Inlet (Also Order Item 4)
6	371505	Clamp, Hose
7	8531670	Fill Valve Assembly
8	304392	Screw
11	8268909	Switch, Overflow Control
12	8545881	Standpipe, Overflow
13	304231	Screw
15	8268913	Float & Retainer Assembly
16	8268892	Lever, Overflow Switch

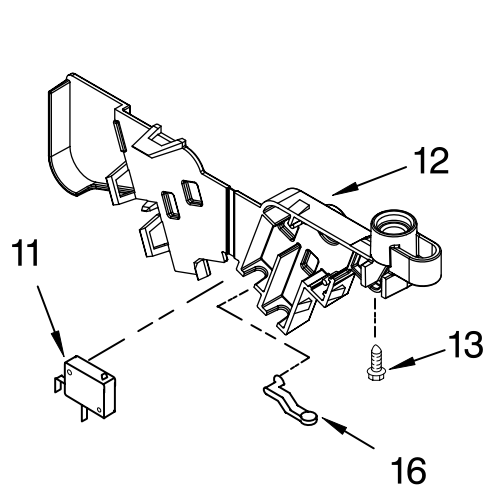
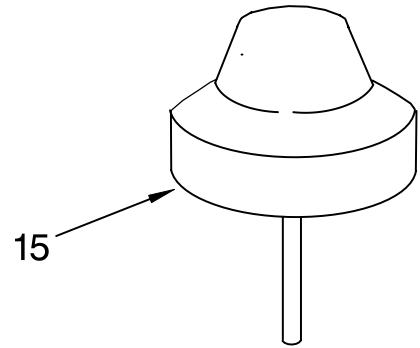

FOR ORDERING INFORMATION REFER TO PARTS PRICE LIST

# TUB AND FRAME PARTS

For Models: DU1100XTPB6, DU1100XTPQ6, DU1100XTPT6, DU1100XTPS6

(Black) (White) (Biscuit) (Stainless)

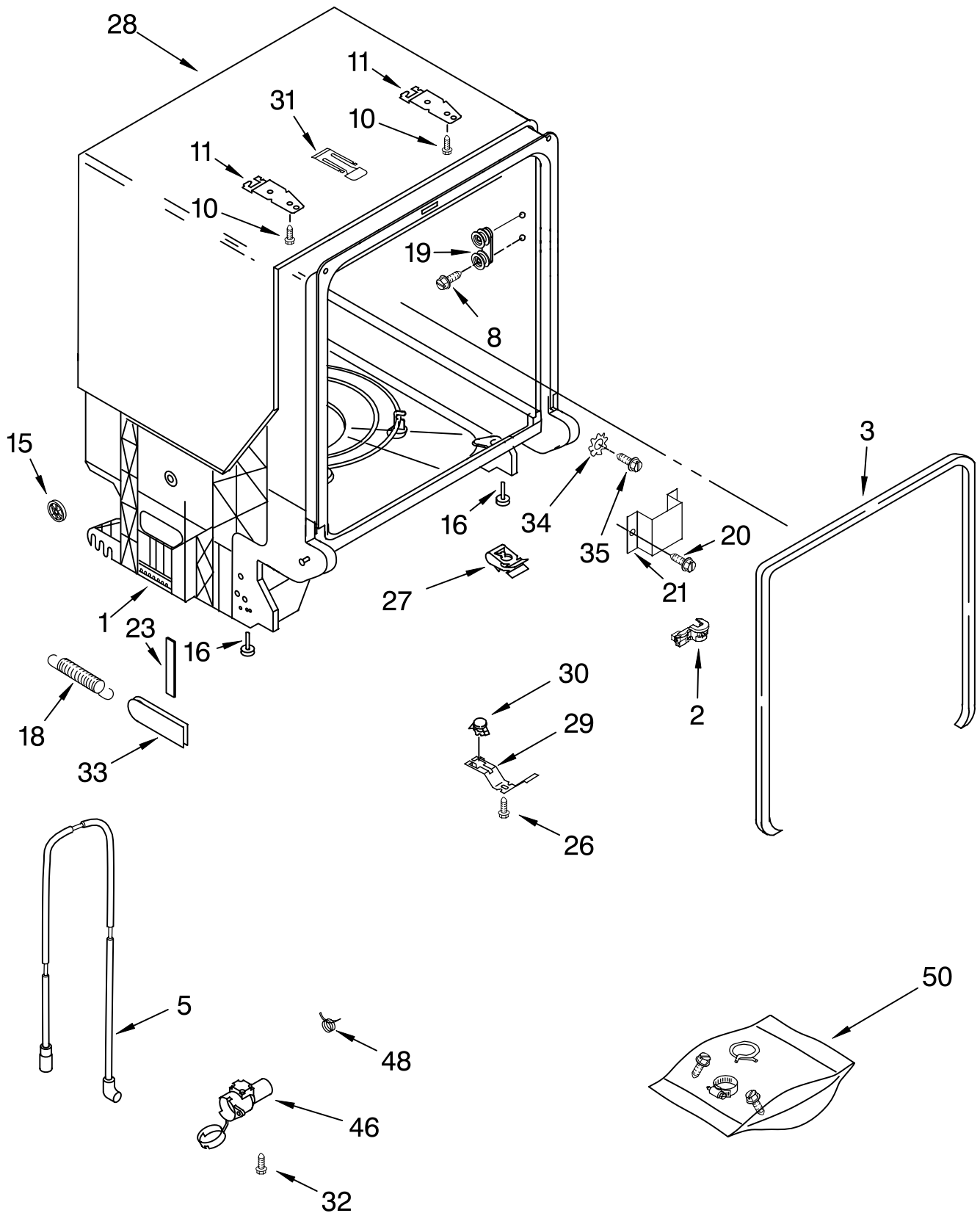

FOR ORDERING INFORMATION REFER TO PARTS PRICE LIST

# TUB AND FRAME PARTS

For Models: DU1100XTPB6, DU1100XTPQ6, DU1100XTPT6, DU1100XTPS6

(Black) (White) (Biscuit) (Stainless)

Illus. No.	Part No.	DESCRIPTION
1	8573152	Tub Assembly
2	8573061	Strain Relief
3	8268888	Door Seal
5	8531022	Drain Loop With Check Valve
8	8533836	Screw (8)
10	3367670	Screw
11	8269145	Bracket, Undercounter
15	8269831	Wheel Leg
16	8524584	Leveler, Leg
18	8524473	Spring, Door Balance
19	8270016	Wheel & Mount Assembly
20	3400892	Screw
21	8268991	Cover, Terminal Box
23	8268961	Pad, Friction
26	304231	Screw
27	8269016	Clip, Grounding
28	8531032	Shield, Sound Tub
29	3378595	Bracket, Thermostat
30	661566	Thermostat
31	8269111	Strike, Latch
32	9741232	Screw
33	8268990	Bushing, Door Spring
34	3378128	Washer
35	3400014	Screw
46	8542575	Switch, Pressure
48	356138	Clamp, Hose (1)
50	8269297	Miscellaneous Parts Bag (Includes 2 Screws & 2 Hose Clamps)



# PUMP AND MOTOR PARTS

For Models: DU1100XTPB6, DU1100XTPQ6, DU1100XTPT6, DU1100XTPS6

(Black)

(White)

(Biscuit)

(Stainless)

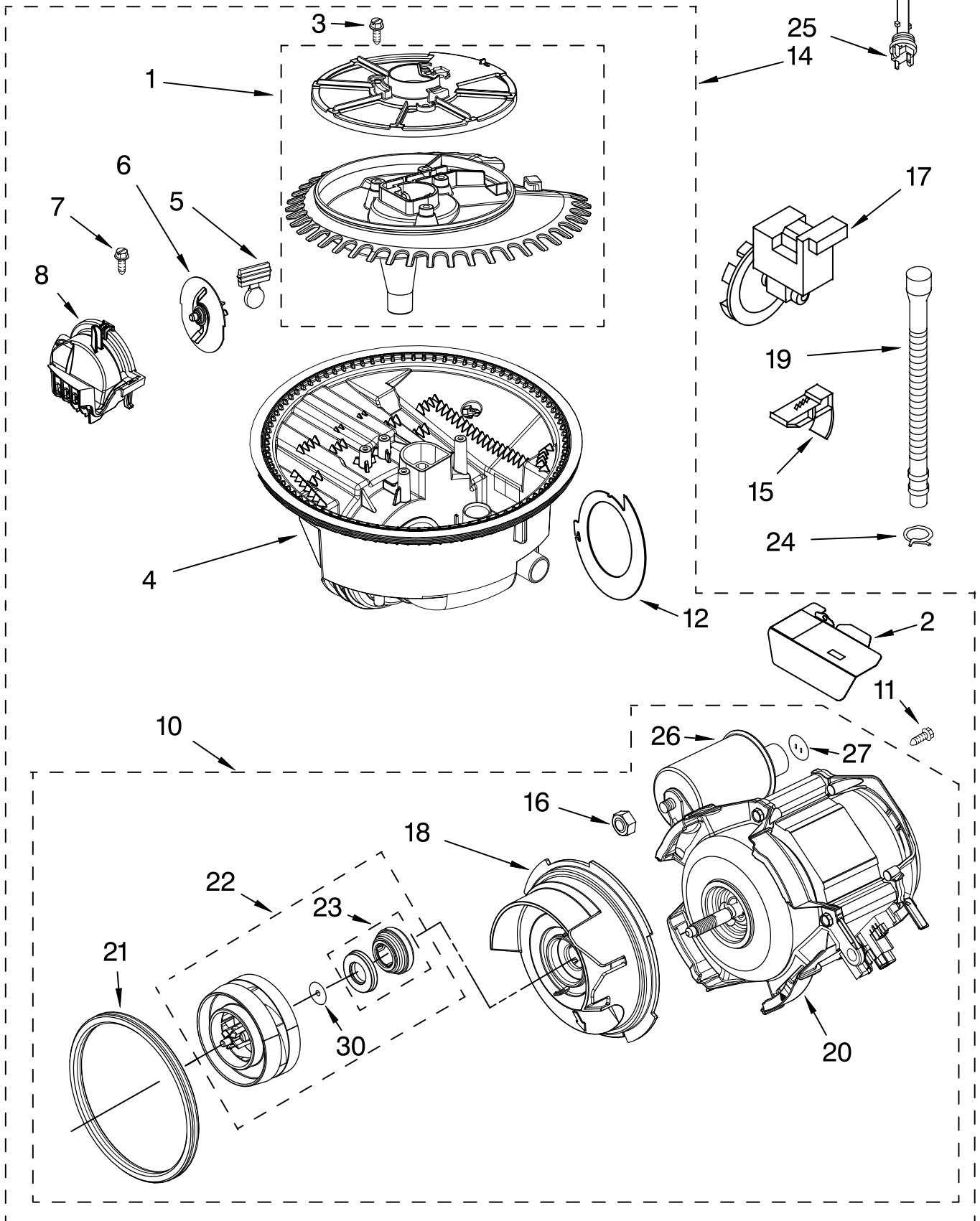

FOR ORDERING INFORMATION REFER TO PARTS PRICE LIST

# PUMP AND MOTOR PARTS

For Models: DU1100XTPB6, DU1100XTPQ6, DU1100XTPT6, DU1100XTPS6

(Black)                      (White)                      (Biscuit)                      (Stainless)

Illus. No.	Part No.	DESCRIPTION
1	8534952	Accumulator Assy
2	8283527	Shield, Motor
3	3400069	Screw
4	8534882	Sump With Seal
5	8268375	Check Valve, Sump
6	8268383	Chopper Assembly
7	9741232	Screw
8	8531857	Protector, Inlet
10	8534942	Motor Assembly
11	3400217	Screw
12	8268391	Screen, Separation
14	8535150	Sump & Motor Assembly
15	8269524	Tab, Sump
16	8533949	Nut
17	661658	Pump, Drain
18	8531019	Volute, Back (Also Order Items 23 & 30)
19	8269144	Hose, Drain
20	8534941	Motor
21	8268397	Seal, Volute
22	8531017	Impeller Kit (Also Order Item 30)
23	8268403	Face Seal Assembly (Also Order Item 30)
24	356138	Clamp, Hose
25	8269208	Thermister
26	8269507	Capacitor
27	8534946	Shield, Capacitor
30	8531018	Washer

# UPPER RACK AND TRACK PARTS

For Models: DU1100XTPB6, DU1100XTPQ6, DU1100XTPT6, DU1100XTPS6

(Black)

(White)

(Biscuit)

(Stainless)

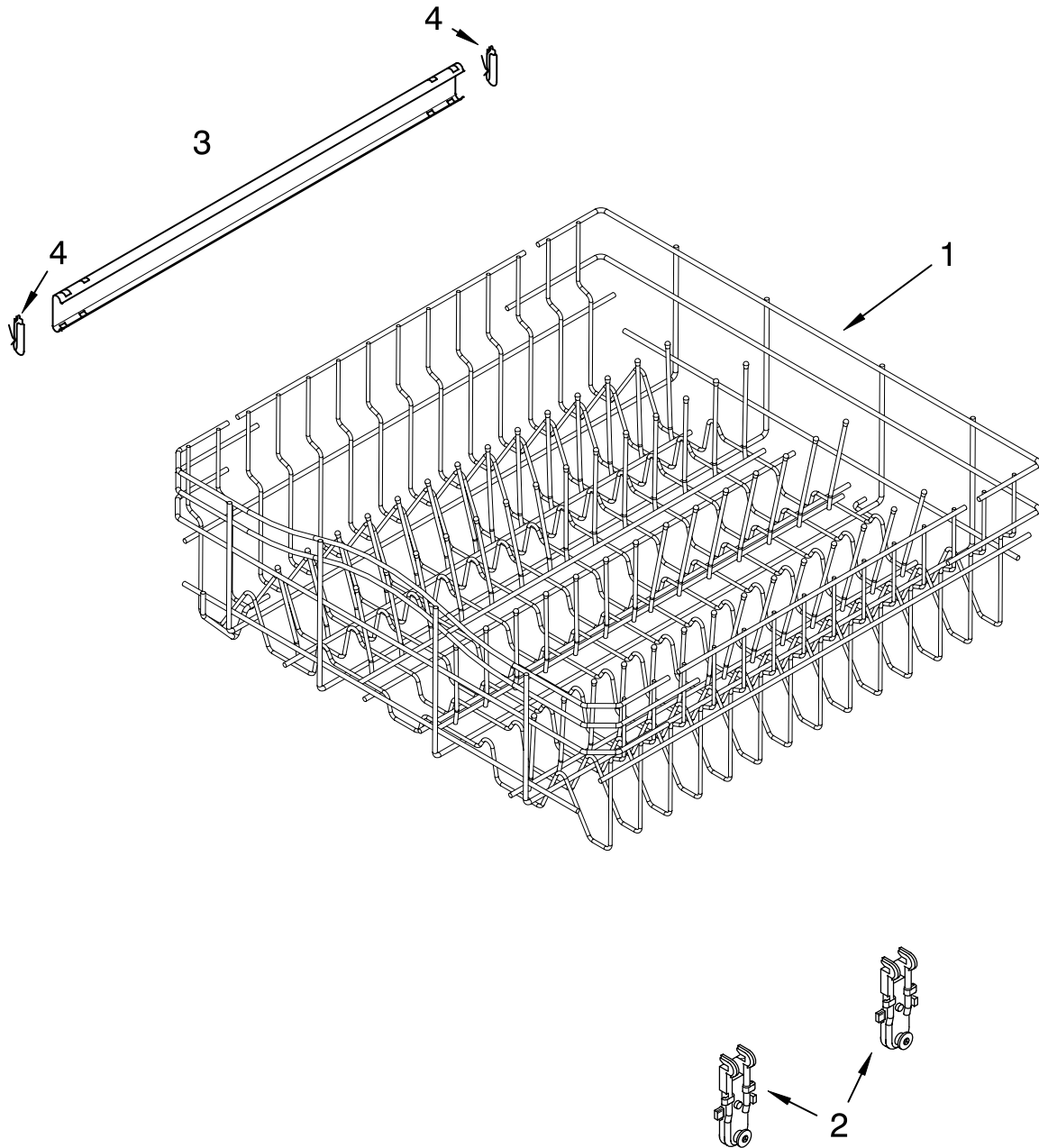

FOR ORDERING INFORMATION REFER TO PARTS PRICE LIST

# UPPER RACK AND TRACK PARTS

For Models: DU1100XTPB6, DU1100XTPQ6, DU1100XTPT6, DU1100XTPS6  
(Black) (White) (Biscuit) (Stainless)

<b>Illus. No.</b>	<b>Part No.</b>	<b>DESCRIPTION</b>
1	8539214	Dishrack, Upper
2	8268655	Mount, Wheel
3	3385089	Track, Rack
4	8524581	Stop Track

FOR ORDERING INFORMATION REFER TO PARTS PRICE LIST

# UPPER WASH AND RINSE PARTS

For Models: DU1100XTPB6, DU1100XTPQ6, DU1100XTPT6, DU1100XTPS6

(Black)

(White)

(Biscuit)

(Stainless)

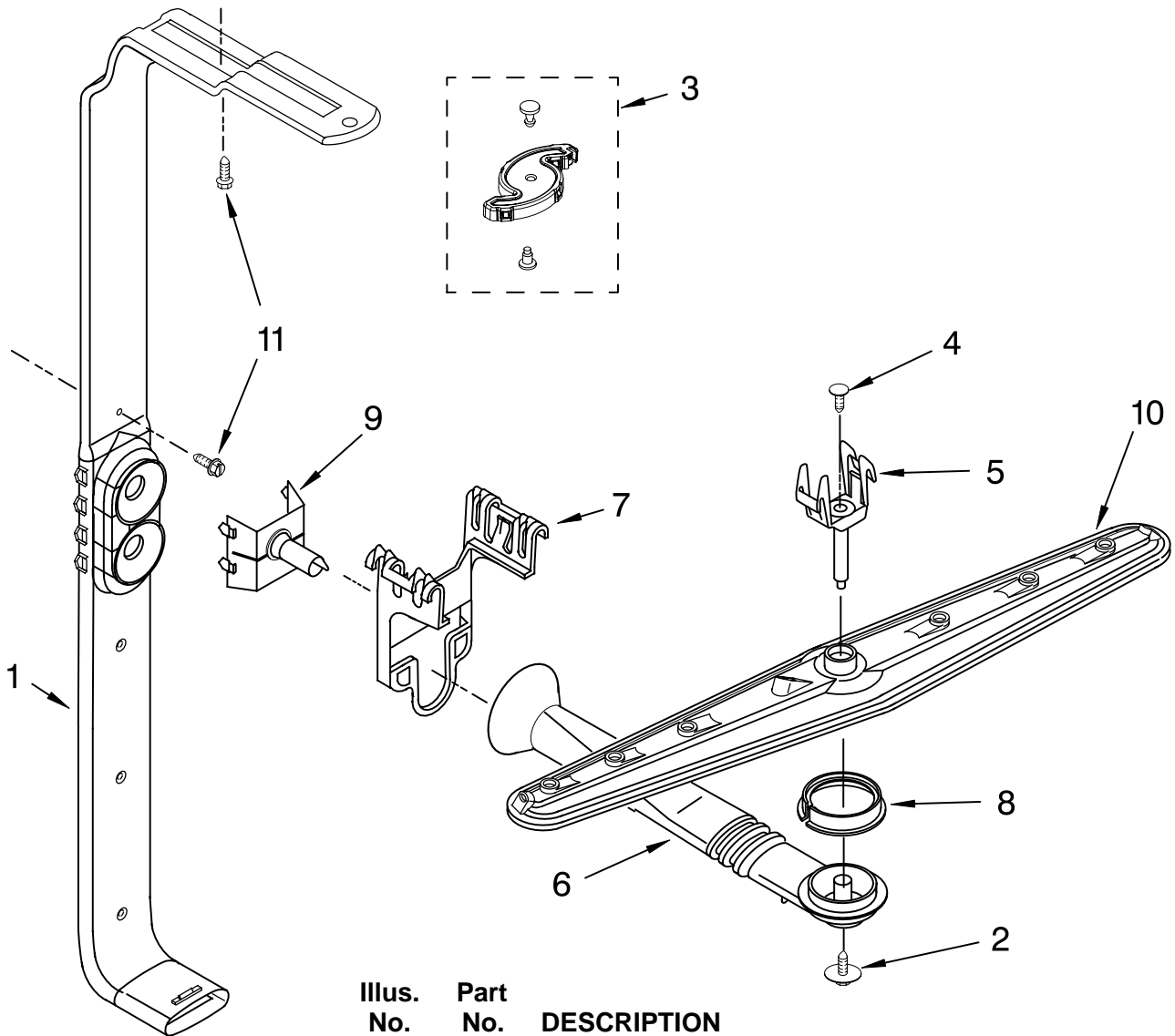

Illus. No.	Part No.	DESCRIPTION
1	8558968	Feed Tube Assembly (Also Includes Items 3 & 9)
2	8533889	Screw
3	8557720	Spinner, 3rd Level Wash
4	3400919	Cover, Screw
5	8268321	Mount
6	8268326	Manifold
7	8268325	Holder, Feed Tube
8	8268433	Seal, Sprayarm
9	8268293	Nozzle
10	8269024	Sprayarm
11	3400850	Screw

FOR ORDERING INFORMATION REFER TO PARTS PRICE LIST

# LOWER RACK PARTS

For Models: DU1100XTPB6, DU1100XTPQ6, DU1100XTPT6, DU1100XTPS6  
 (Black) (White) (Biscuit) (Stainless)

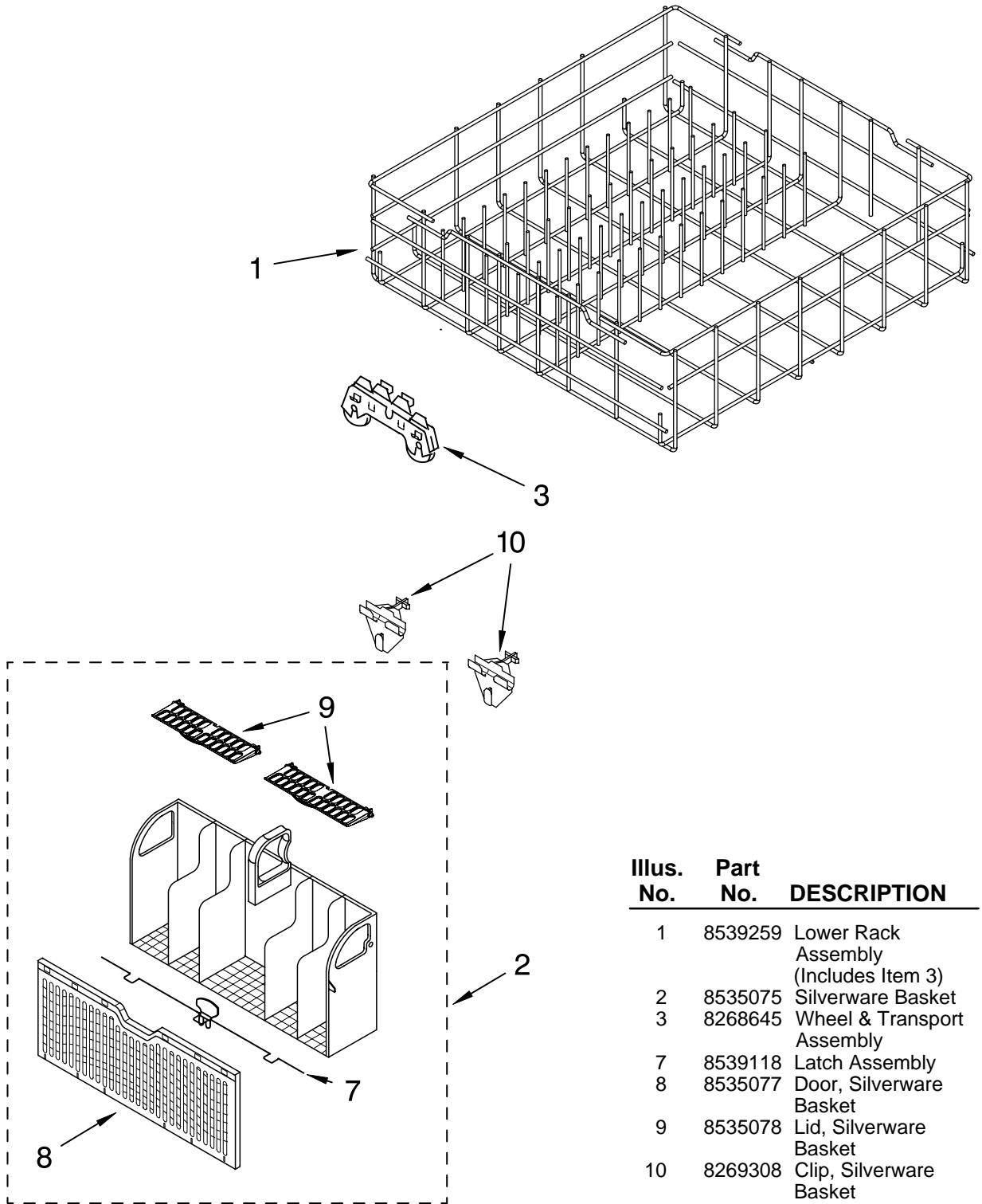

Illus. No.	Part No.	DESCRIPTION
1	8539259	Lower Rack Assembly (Includes Item 3)
2	8535075	Silverware Basket
3	8268645	Wheel & Transport Assembly
7	8539118	Latch Assembly
8	8535077	Door, Silverware Basket
9	8535078	Lid, Silverware Basket
10	8269308	Clip, Silverware Basket

FOR ORDERING INFORMATION REFER TO PARTS PRICE LIST

**OPTIONAL PARTS (NOT INCLUDED)**  
For Models: DU1100XTPB6, DU1100XTPQ6, DU1100XTPT6, DU1100XTPS6  
(Black) (White) (Biscuit) (Stainless)

**Illus. Part**  
**No. No. DESCRIPTION**

---

**ACCESSORIES**

SIDE PANEL KITS  
8171656 White  
8171657 Black  
8171658 Biscuit  
8171659 Stainless Steel  
Custom Panel Kits  
4396199 Black  
4396200 White  
4396201 Biscuit  
Cabinet Seal Kit  
8269110 Seal, Kit

**PAINT, TOUCH-UP (1/2oz.)**

72017 White  
72032 Black  
4392899 Biscuit

**PAINT, PRESSURIZED SPRAY**  
**(12 oz.)**

350930 White  
285006 Superior Black  
4392901 Biscuit

**PAINT, BULK (1 qt.)**

799344 White (Uncut)  
4392900 Biscuit

**POWER CORD KIT**

4317824 Power Cord Kit  
(Includes Power  
Cord & Misc.  
Hardware)

**ANTI-TIP KIT**

4396194 Floor Mount Kit