

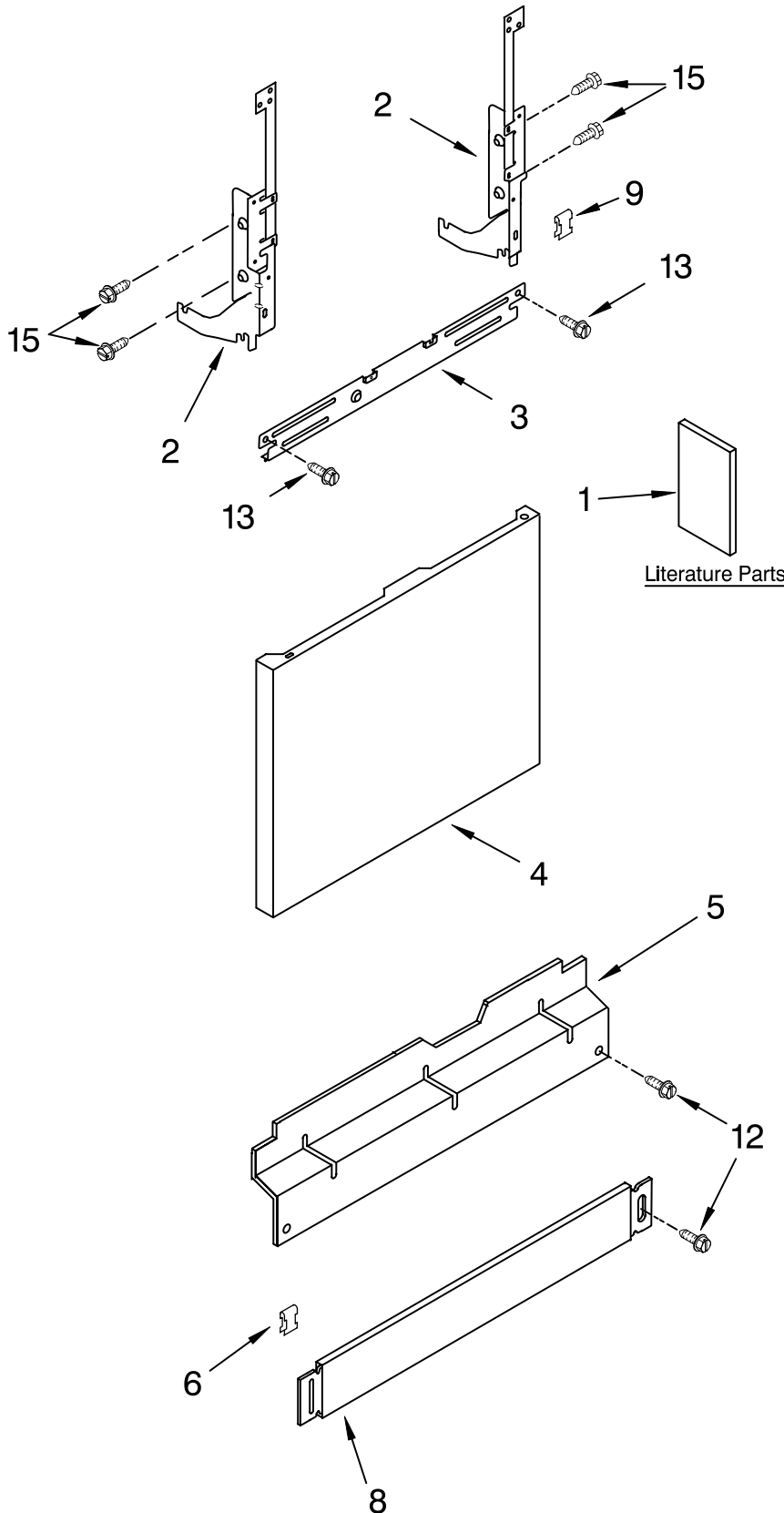

# DOOR AND PANEL PARTS

For Models: DU1055XTSB1, DU1055XTSQ1, DU1055XTST1, DU1055XTSS1  
(Black) (White) (Biscuit) (Stainless)

UNDERCOUNTER  
DISHWASHER



Illus. No.	Part No.	DESCRIPTION
1	8575348	Literature Parts Instructions, Installation
	W10066090	Energy Guide
	W10073760	Guide, Use & Care
	W10082651	Tech Sheet
2	8534858	Arm, Hinge Left
	8534857	Right
3	8268983	Stiffener, Door
4		Panel Front
	W10073170	Black
	W10073180	White
	W10073190	Biscuit
	8528840	Stainless
5		Access Panel
	8573255	Black
	8573256	White
	8573257	Biscuit
6	8269016	Clip, Grounding
8		Toe Panel (Includes Item 6)
	8573286	Black
	8573287	White
	8573288	Biscuit
9	8269740	Clip, Grounding
12		Screw
	302868	Black
	3400836	White
	3400865	Biscuit
13	343641	Screw
15	489470	Screw

FOR ORDERING INFORMATION REFER TO PARTS PRICE LIST

# CONTROL PANEL PARTS

For Models: DU1055XTSB1, DU1055XTSQ1, DU1055XTST1, DU1055XTSS1  
 (Black) (White) (Biscuit) (Stainless)

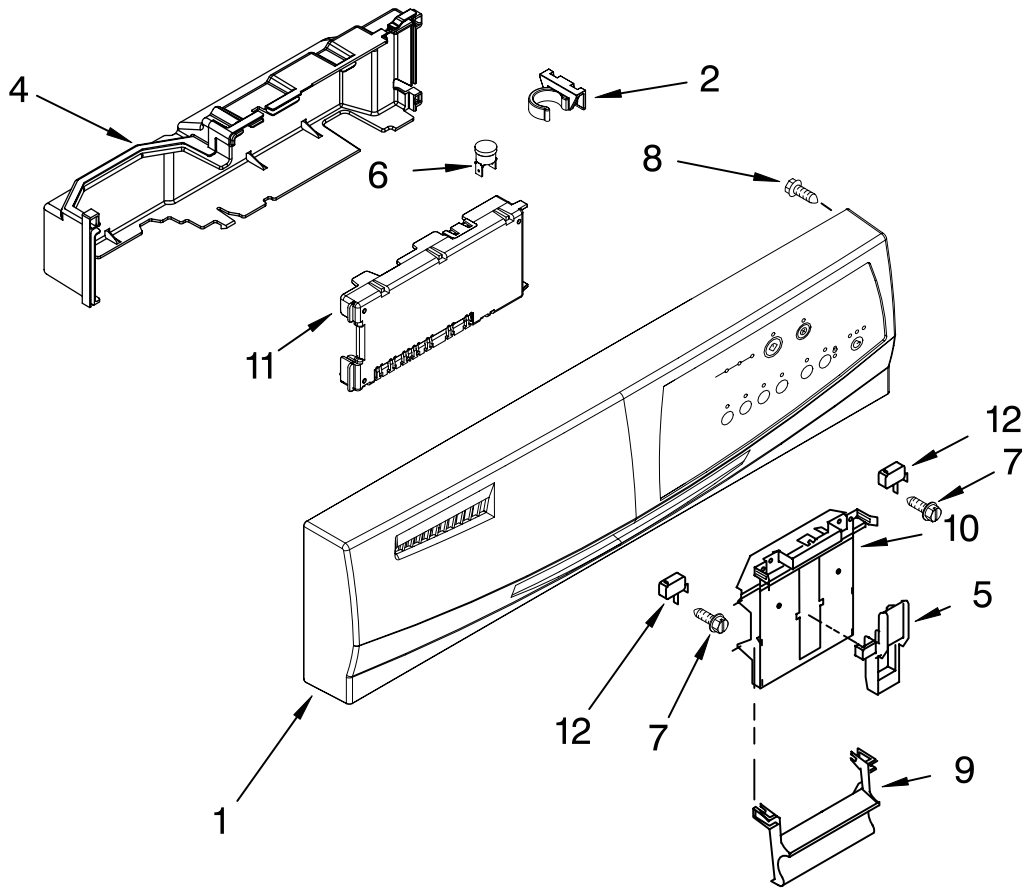

Illus. No.	Part No.	DESCRIPTION
1		Console Asm. (Includes Active Overlay & Insert)
	W10102453	Black
	W10102454	White
	W10102455	Biscuit
2	8546546	Clip, BI-Metal
4	W10056090	Cover Control Shield Assembly
5	8524472	Actuator, Latch
6	661663	BI-Metal
7	3400412	Screw
8	3369051	Screw (6)
9		Handle, Latch
	8534984	Black
	8534985	White
	8534986	Biscuit
10	8524476	Bolt, Latch
11	8575277	Control, Electronic
12	8269209	Switch, Door

FOR ORDERING INFORMATION REFER TO PARTS PRICE LIST

# DOOR AND LATCH PARTS

For Models: DU1055XTSB1, DU1055XTSQ1, DU1055XTST1, DU1055XTSS1  
 (Black) (White) (Biscuit) (Stainless)

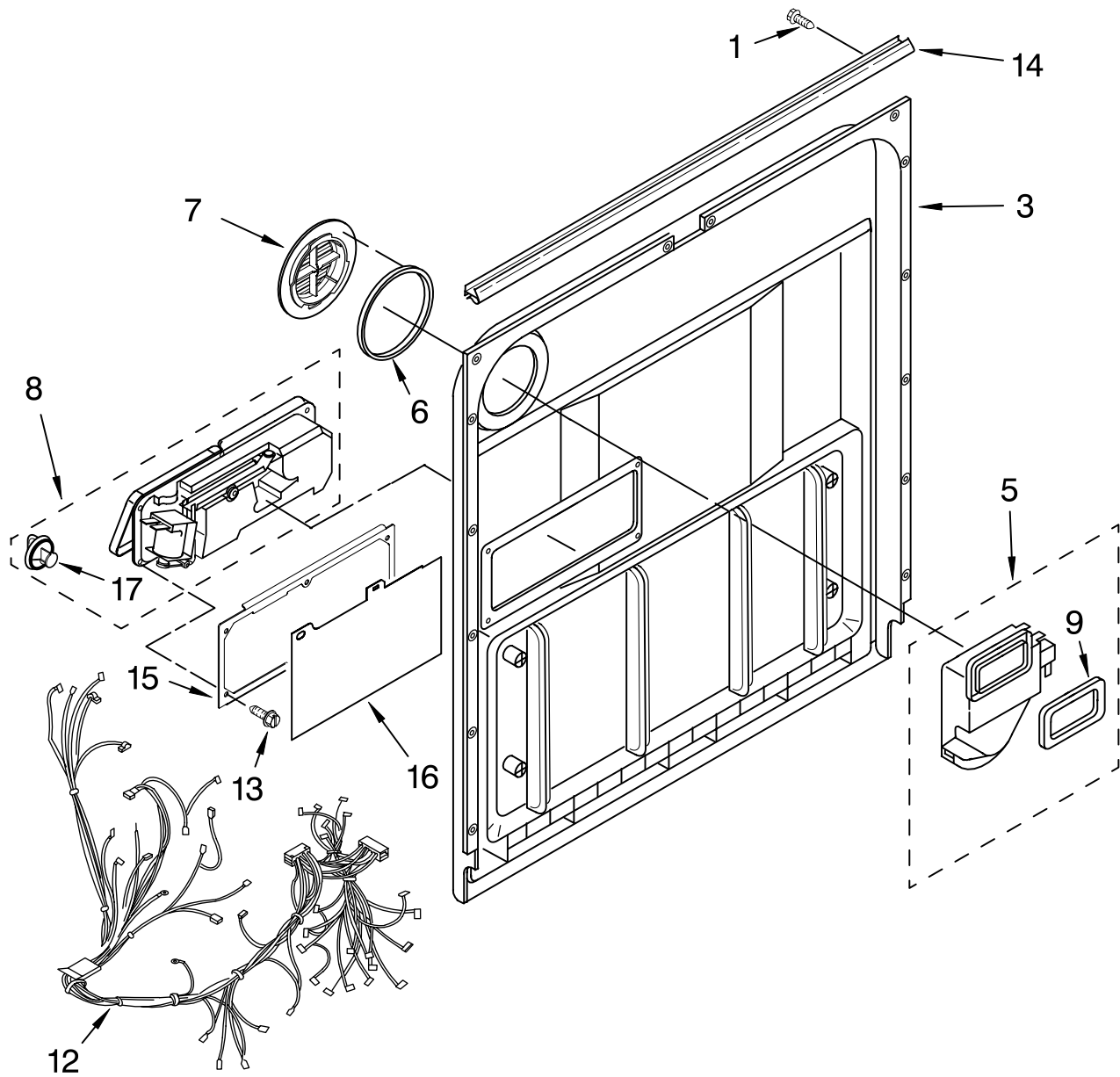

Illus. No.	Part No.	DESCRIPTION	Illus. No.	Part No.	DESCRIPTION	Illus. No.	Part No.	DESCRIPTION
1	3369051	Screw, Door	7	8542566	Deflector, Vent (Also Order Item 6)	12	W10070130	Wiring Harness Main
3	8269311	Inner Door (Also Order Item 6)	8	8565814	Dispenser, Assembly	13	8281154	Screw
5	8542603	Vent Assembly (Also Order Item 6)	9	8269258	Seal, Front	14	8269296	Seal, Console/door
6	8269259	Gasket, Vent				15	8535637	Bracket, Dispenser
						16	8531865	Shield, Dispenser
						17	8558307	Cap, Rinse Aid

FOR ORDERING INFORMATION REFER TO PARTS PRICE LIST

# LOWER WASHARM PARTS

For Models: DU1055XTSB1, DU1055XTSQ1, DU1055XTST1, DU1055XTSS1  
 (Black) (White) (Biscuit) (Stainless)

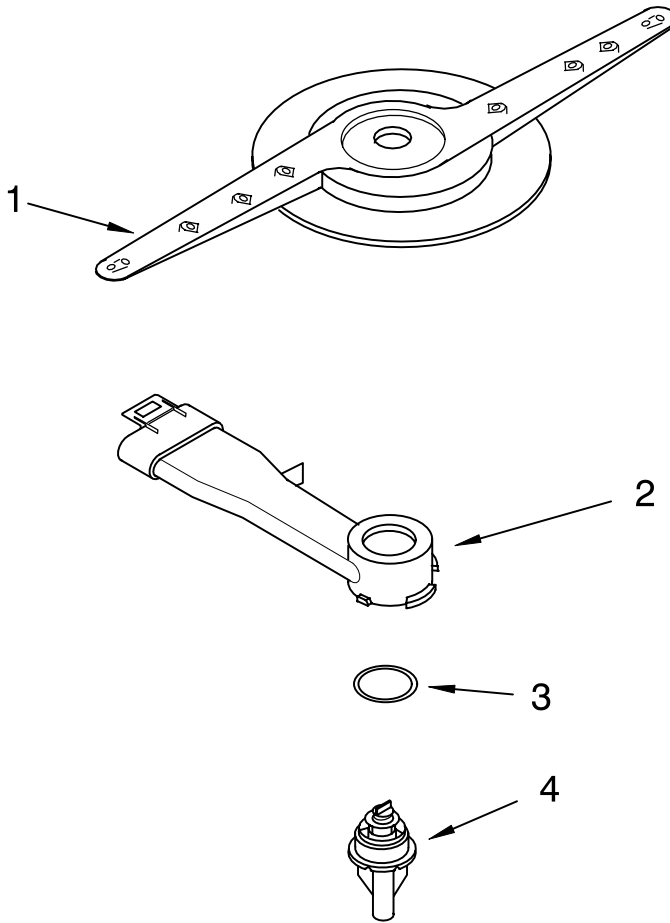

Illus. No.	Part No.	DESCRIPTION
1	8268333	Wash Arm Assembly
2	8268317	Cap, Internal Rear Feed (Also Order Item 3)
3	8268340	Seal, Sprayarm
4	8268342	Hub, Lower Sprayarm (Also Order Item 3)

FOR ORDERING INFORMATION REFER TO PARTS PRICE LIST

# HEATER PARTS

For Models: DU1055XTSB1, DU1055XTSQ1, DU1055XTST1, DU1055XTSS1  
(Black) (White) (Biscuit) (Stainless)

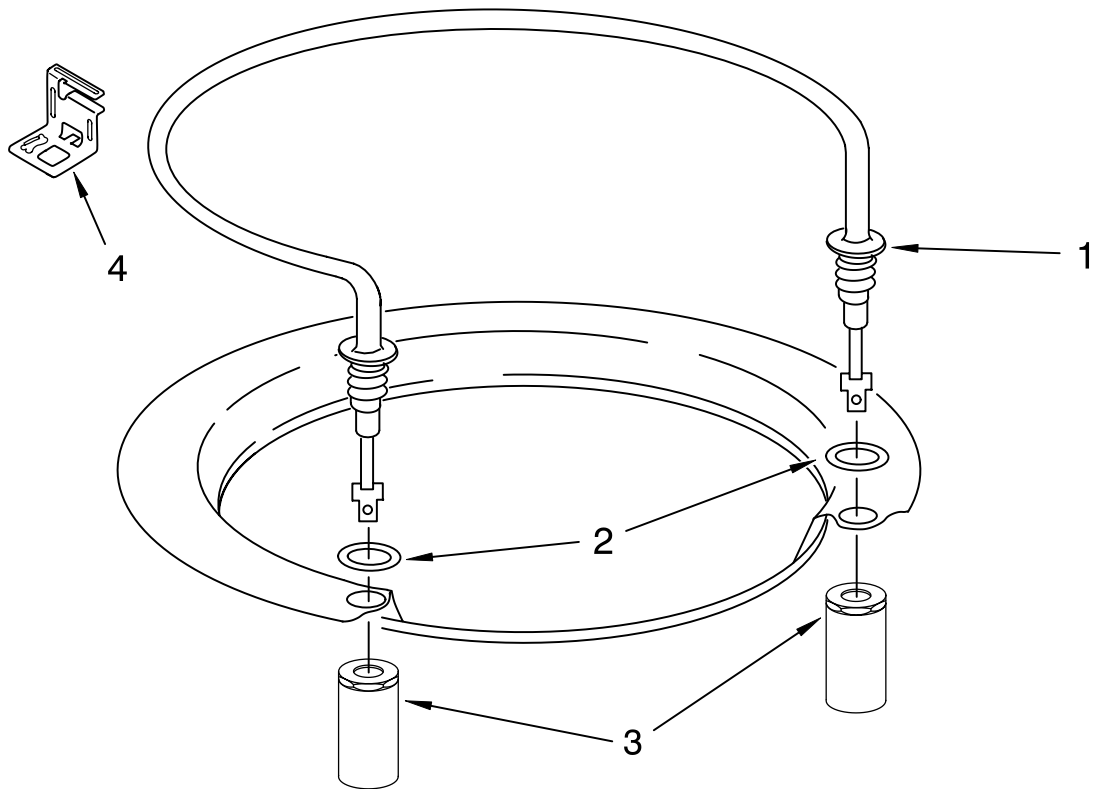

<u>Illus. No.</u>	<u>Part No.</u>	<u>DESCRIPTION</u>
1	8563007	Heater Element Assembly (Also Includes Item 2)
2	717273	Washer, Heater Element
3	8268548	Nut, Heater Element
4	8269262	Bracket, Heater Support

**NOTE:** If heater element is removed, it must be replaced.

FOR ORDERING INFORMATION REFER TO PARTS PRICE LIST

# FILL AND OVERFILL PARTS

For Models: DU1055XTSB1, DU1055XTSQ1, DU1055XTST1, DU1055XTSS1  
 (Black) (White) (Biscuit) (Stainless)

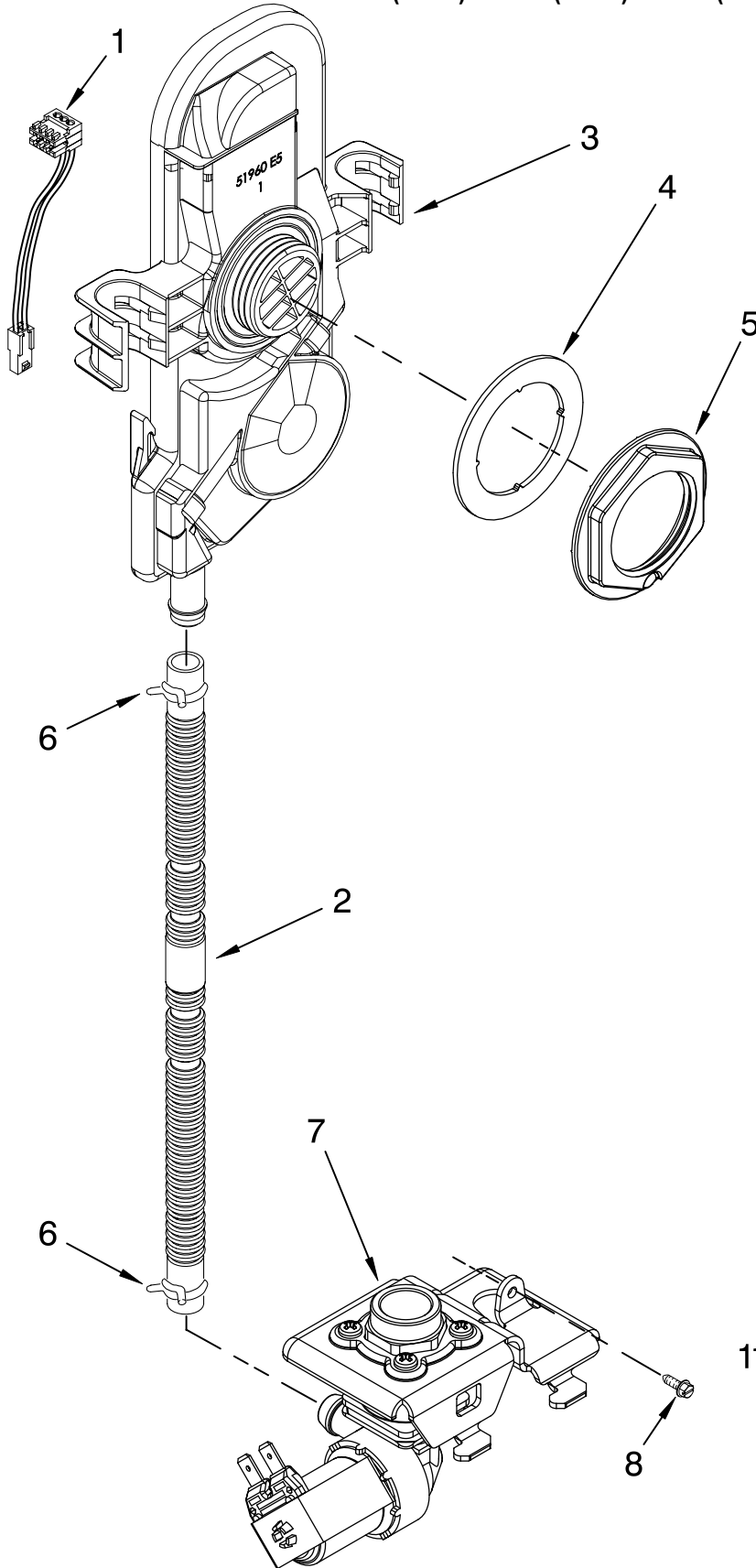

Illus. No.	Part No.	DESCRIPTION
1	W10070120	Wire, Jumper
2	W10041920	Hose, Inlet
3	W10041900	Water Inlet (Also Order Item 4)
4	8531323	Gasket
5	8531326	Nut, Inlet (Also Order Item 4)
6	371505	Clamp, Hose
7	8563405	Fill Valve Assembly
8	304392	Screw
11	8268909	Switch, Overfill Control
12	8545881	Standpipe, Overflow
13	304231	Screw
15	8268913	Float & Retainer Assembly
16	8268892	Lever, Overflow Switch

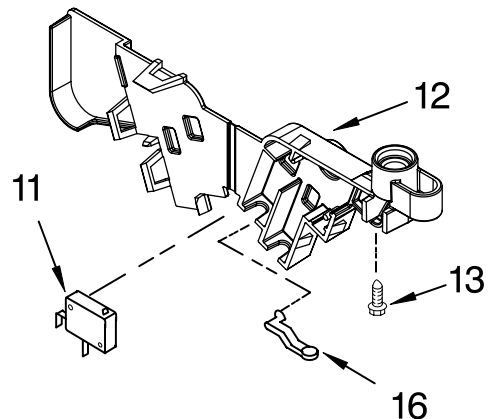
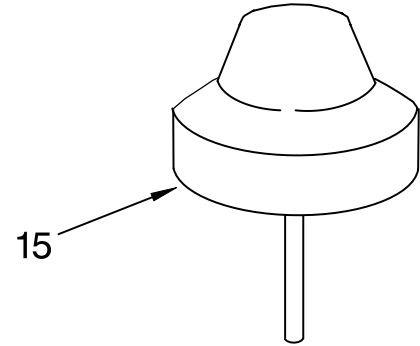

FOR ORDERING INFORMATION REFER TO PARTS PRICE LIST

# TUB AND FRAME PARTS

For Models: DU1055XTSB1, DU1055XTSQ1, DU1055XTST1, DU1055XTSS1  
(Black) (White) (Biscuit) (Stainless)

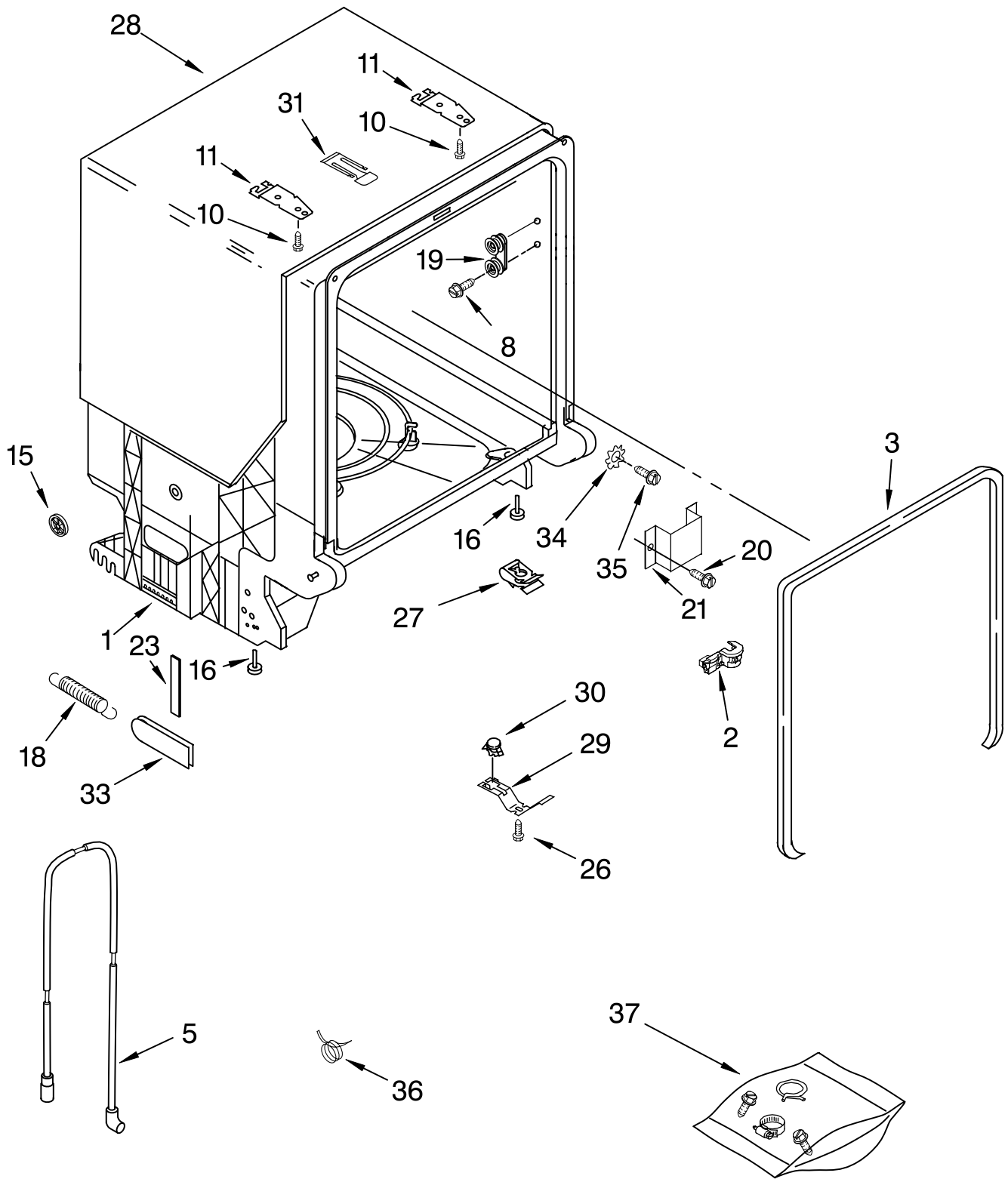

FOR ORDERING INFORMATION REFER TO PARTS PRICE LIST

# TUB AND FRAME PARTS

For Models: DU1055XTSB1, DU1055XTSQ1, DU1055XTST1, DU1055XTSS1  
 (Black) (White) (Biscuit) (Stainless)

Illus. No.	Part No.	DESCRIPTION
1	W10008370	Tub Assembly
2	8573061	Strain Relief
3	8268888	Door Seal
5	8531022	Drain Loop With Check Valve
8	8533836	Screw (8)
10	3367670	Screw
11	8269145	Bracket, Undercounter
15	8269831	Wheel Leg
16	8524584	Leveler, Leg
18	8524473	Spring, Door Balance
19	8270016	Wheel & Mount Assembly
20	3400892	Screw
21	8268991	Cover, Terminal Box
23	8268961	Pad, Friction
26	304231	Screw
27	8269016	Clip, Grounding
28	8573240	Shield, Sound Tub
29	3378595	Bracket, Thermostat
30	661566	Thermostat
31	8580309	Strike, Latch
33	8268990	Bushing, Door Spring
34	3378128	Washer
35	3400014	Screw
36	356138	Clamp, Hose (1)
37	8269297	Miscellaneous Parts Bag (Includes 2 Screws & 2 Hose Clamps)



# PUMP AND MOTOR PARTS

For Models: DU1055XTSB1, DU1055XTSQ1, DU1055XTST1, DU1055XTSS1  
 (Black) (White) (Biscuit) (Stainless)

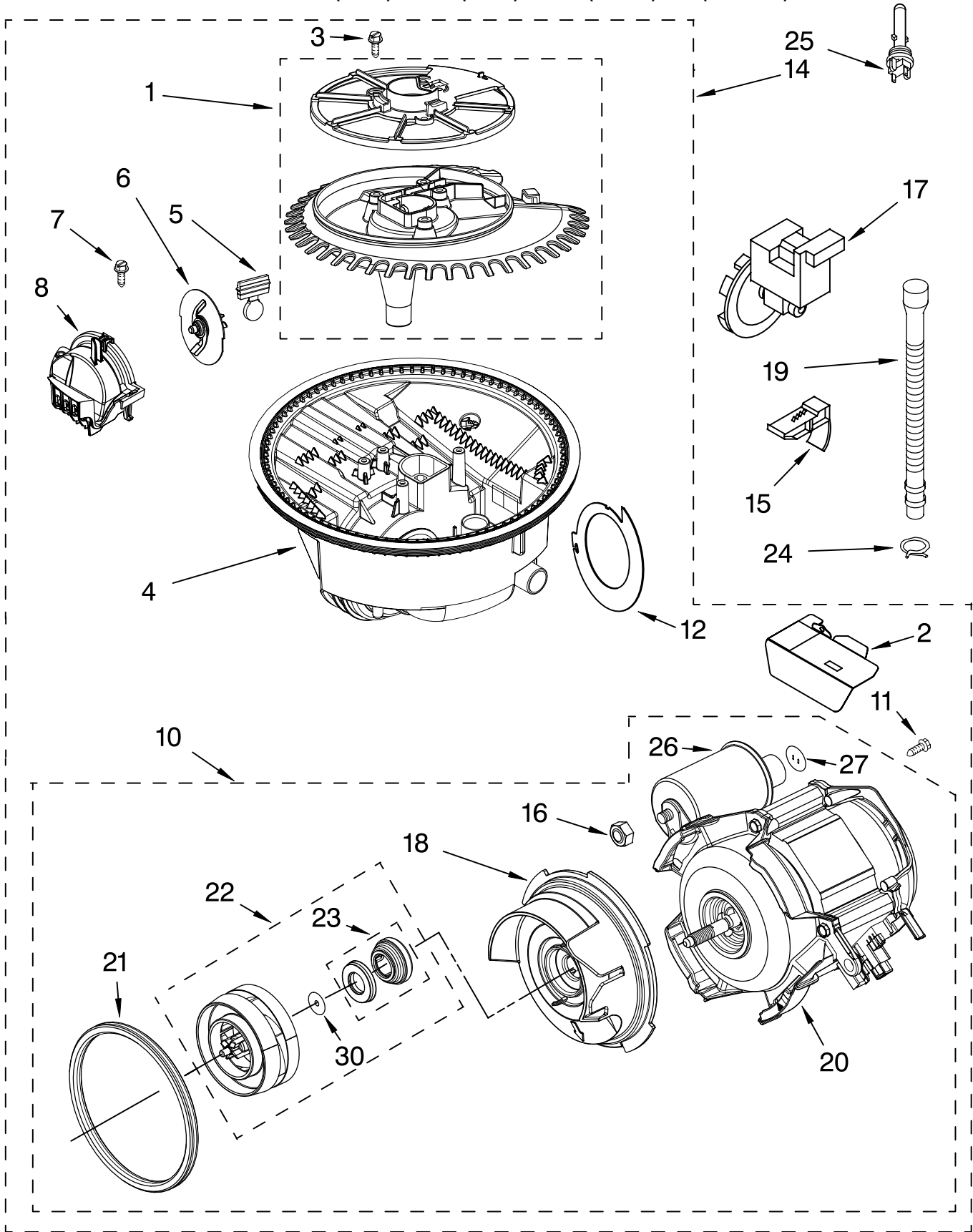

FOR ORDERING INFORMATION REFER TO PARTS PRICE LIST

# PUMP AND MOTOR PARTS

For Models: DU1055XTSB1, DU1055XTSQ1, DU1055XTST1, DU1055XTSS1  
 (Black) (White) (Biscuit) (Stainless)

Illus. No.	Part No.	DESCRIPTION
1	8534952	Accumulator Assy
2	8283527	Shield, Motor
3	3400069	Screw
4	8572618	Sump With Seal
5	8268375	Check Valve, Sump
6	8268383	Chopper Assembly
7	9741232	Screw
8	8531857	Protector, Inlet
10	8534942	Motor Assembly
11	3400217	Screw
12	8268391	Screen, Separation
14	8572615	Sump & Motor Assembly
15	8269524	Tab, Sump
16	8533949	Nut
17	661662	Pump, Drain
18	8531019	Volute, Back (Also Order Items 23 & 30)
19	8269144	Hose, Drain
20	8534941	Motor
21	8268397	Seal, Volute
22	8531017	Impeller Kit (Also Order Item 30)
23	8268403	Face Seal Assembly (Also Order Item 30)
24	356138	Clamp, Hose
25	8578828	Thermister
26	8269507	Capacitor
27	8534946	Shield, Capacitor
30	8531018	Washer

# UPPER RACK AND TRACK PARTS

For Models: DU1055XTSB1, DU1055XTSQ1, DU1055XTST1, DU1055XTSS1  
(Black) (White) (Biscuit) (Stainless)

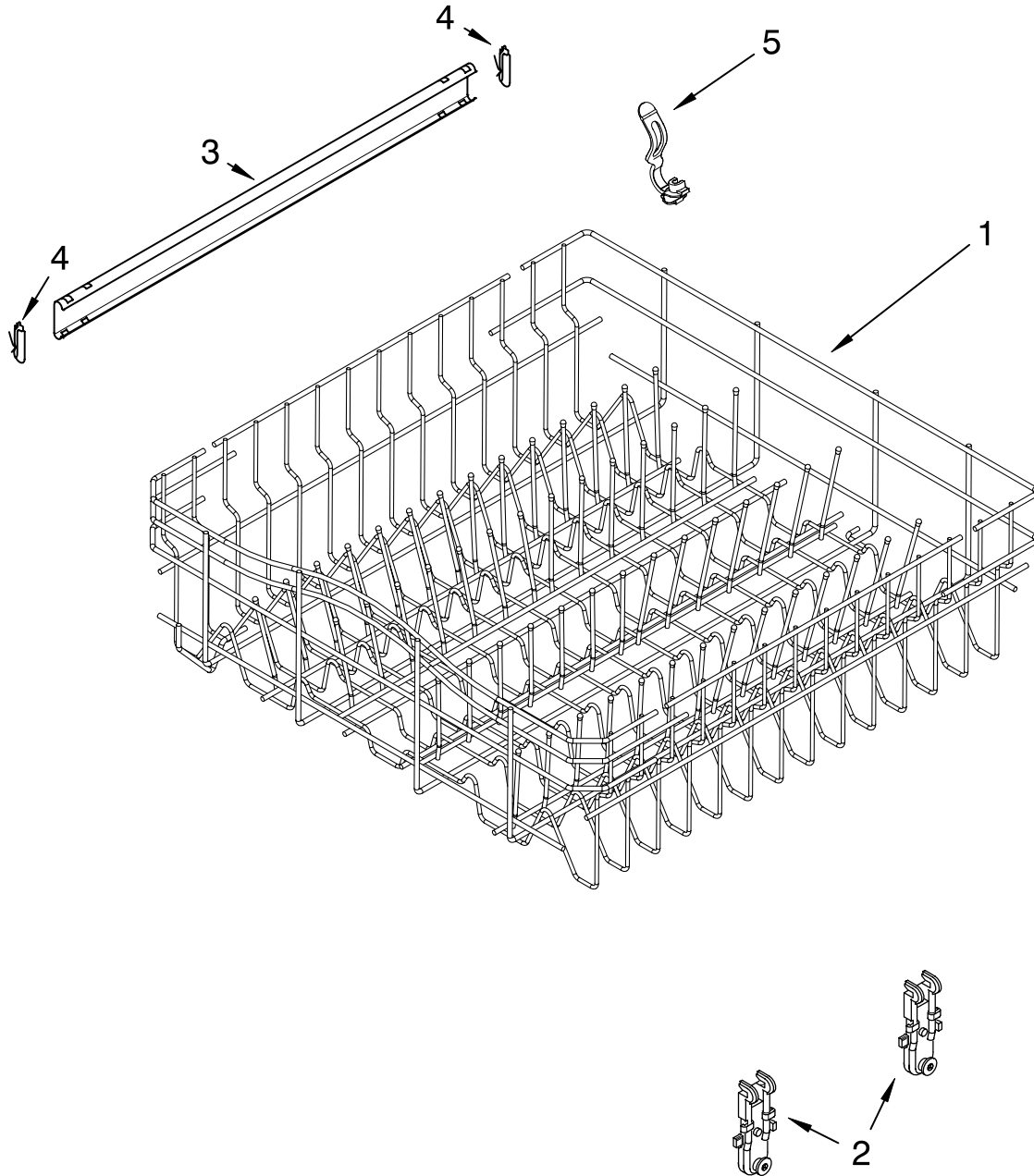

FOR ORDERING INFORMATION REFER TO PARTS PRICE LIST

# UPPER RACK AND TRACK PARTS

For Models: DU1055XTSB1, DU1055XTSQ1, DU1055XTST1, DU1055XTSS1  
(Black) (White) (Biscuit) (Stainless)

<b>Illus. No.</b>	<b>Part No.</b>	<b>DESCRIPTION</b>
1	8539214	Dishrack, Upper
2	8268655	Mount, Wheel
3	3385089	Track, Rack
4	8565920	Stop Track
5	8539113	Clip, No-Flip

# UPPER WASH AND RINSE PARTS

For Models: DU1055XTSB1, DU1055XTSQ1, DU1055XTST1, DU1055XTSS1  
 (Black) (White) (Biscuit) (Stainless)

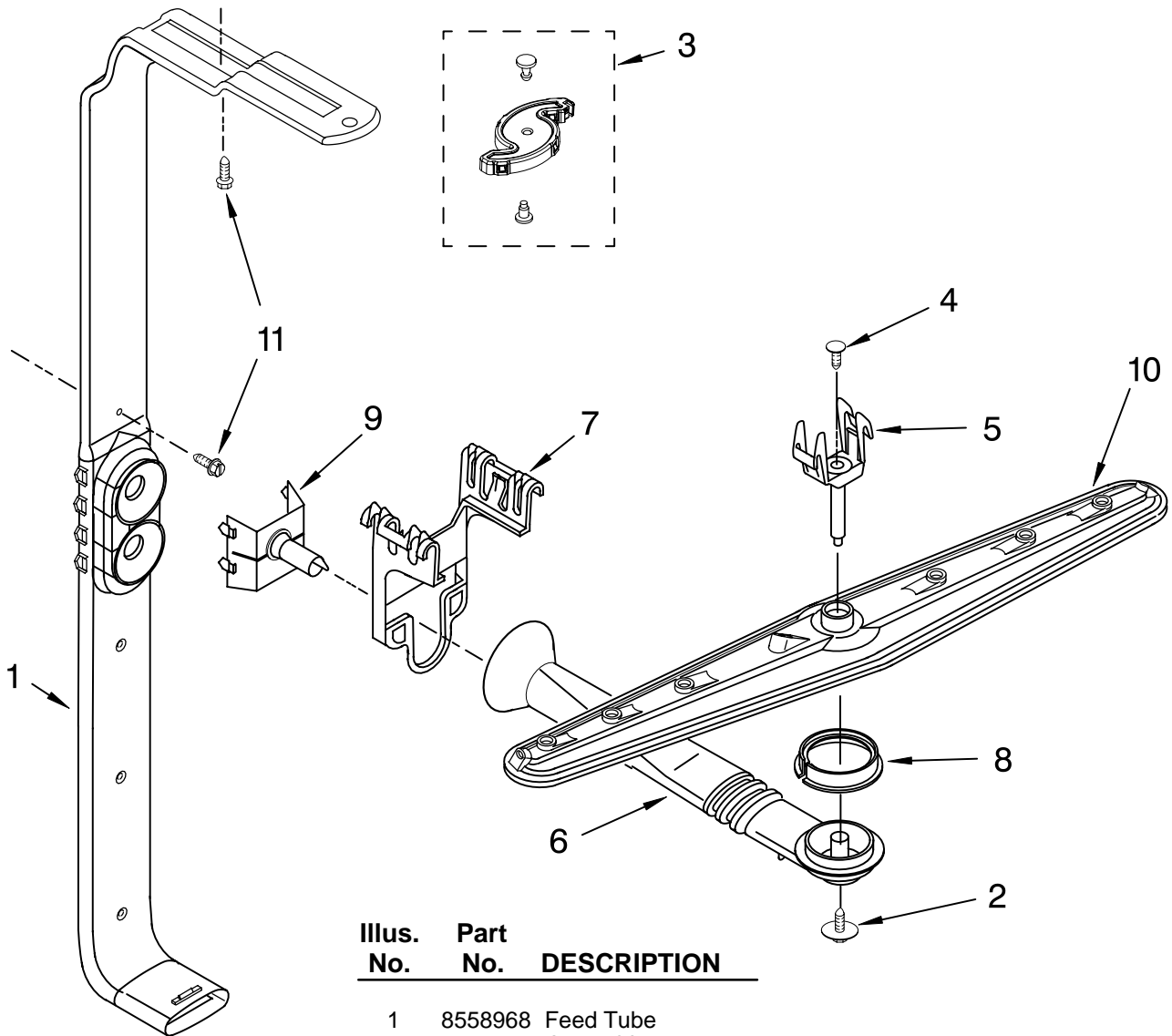

Illus. No.	Part No.	DESCRIPTION
1	8558968	Feed Tube Assembly (Also Includes Items 3 & 9)
2	8533889	Screw
3	8557720	Spinner, 3rd Level Wash
4	3400919	Cover, Screw
5	8268321	Mount
6	8268326	Manifold
7	8268325	Holder, Feed Tube
8	8268433	Seal, Sprayarm
9	8268293	Nozzle
10	8269024	Sprayarm
11	3400850	Screw

FOR ORDERING INFORMATION REFER TO PARTS PRICE LIST

# LOWER RACK PARTS

For Models: DU1055XTSB1, DU1055XTSQ1, DU1055XTST1, DU1055XTSS1  
 (Black) (White) (Biscuit) (Stainless)

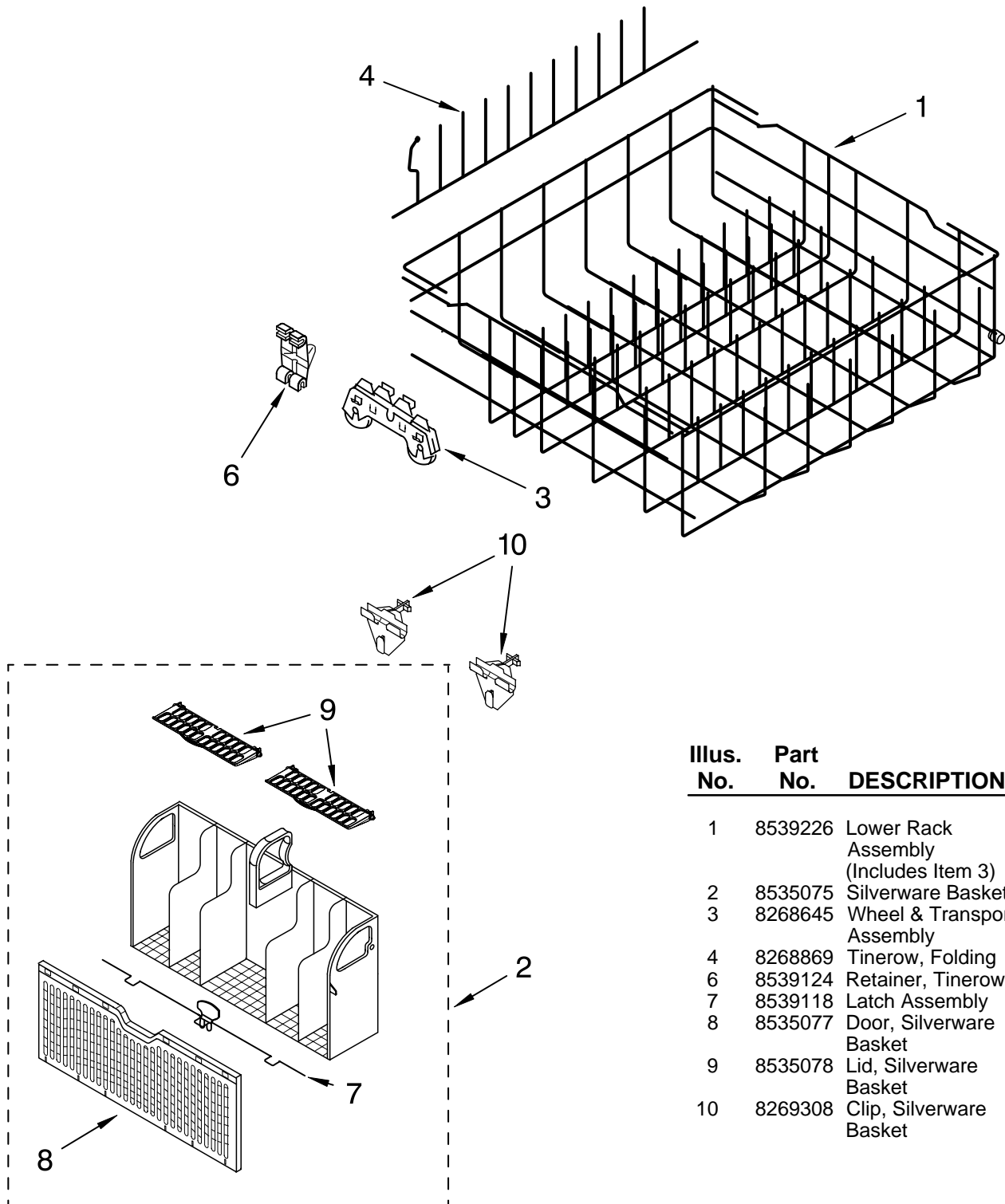

Illus. No.	Part No.	DESCRIPTION
1	8539226	Lower Rack Assembly (Includes Item 3)
2	8535075	Silverware Basket
3	8268645	Wheel & Transport Assembly
4	8268869	Tinerow, Folding
6	8539124	Retainer, Tinerow
7	8539118	Latch Assembly
8	8535077	Door, Silverware Basket
9	8535078	Lid, Silverware Basket
10	8269308	Clip, Silverware Basket

FOR ORDERING INFORMATION REFER TO PARTS PRICE LIST

# OPTIONAL PARTS (NOT INCLUDED)

For Models: DU1055XTSB1, DU1055XTSQ1, DU1055XTST1, DU1055XTSS1  
 (Black) (White) (Biscuit) (Stainless)

Illus. Part No. No. DESCRIPTION	Illus. Part No. No. DESCRIPTION	Illus. Part No. No. DESCRIPTION
<b><u>ACCESSORIES</u></b>		
Side Panel Kits 8171656 White 8171657 Black 8171658 Biscuit 8171659 Stainless Steel	<b><u>PAINT, PRESSURIZED SPRAY (12 oz.)</u></b>  350930 White 285006 Superior Black 4392901 Biscuit	<b><u>ANTI-TIP KIT</u></b>  4396194 Floor Mount Kit
Custom Panel & Trim Kit 4396196 Black 4396197 White 4396198 Biscuit	<b><u>PAINT, BULK (1 qt.)</u></b>  799344 White (Uncut) 4392900 Biscuit	<b><u>DISHRACK REPAIR</u></b>  Tip Tine Repair Kit (Enough for Two Complete Dishracks)  4396838 White 4396840 Grey
Moisture Barrier Kit 4396277 Kit	<b><u>POWER CORD KIT</u></b>  4317824 Power Cord Kit (Includes Power Cord & Misc. Hardware)	Vinyl Touch-Up (4 oz.) 676453 White 676455 Grey
Drain Hose 3385556 12 Ft.		
<b><u>PAINT, TOUCH-UP (1/2oz.)</u></b>		
72017 White 72032 Black 4392899 Biscuit 4396603 Meteorite		

FOR ORDERING INFORMATION REFER TO PARTS PRICE LIST