



# KITCHEN CLEANUP

## Built-In 24"W. Dishwasher 325



### Standard Features & Accessories

#### All models include:

- **Exclusive** Vari-Pressure Intelli-Wash™ System
  - **Exclusive** variable speed 1/2 horsepower commercial-type motor
  - **Exclusive** multi-level washing with two stainless steel wash arms
  - **Exclusive** Block-proof Flexible-Fluid™ coupling direct water feed
- **Exclusive** Central Intelligence™ System
  - Constant communication
  - Measures water temperature and water volume
- **Exclusive** Four-Stage Filtration and Waste Removal System
  - Removable coarse strainer
  - **Exclusive** Triple-Clean™ filtration with self-cleaning jets
- **Exclusive** Sure-Temp™ Water Heating
  - 1400 watt HydroFlo™ water heater
  - Operable with “cold” ground water
- Condensate Quick Dry
- QuietClean™ Performance Package
  - Separate motor/pump assemblies for washing and draining
  - Multi-stage sound absorbing/heat retaining insulation
  - Blue LED power-on light in kickplate indicates cycle is operating
- “Load-As-You-Like” Sturdi-Bilt™ Racks
  - Accommodates 15 international place settings
  - Fully extendable nylon coated racks
  - One-Piece silverware/cutlery basket
  - Lower rack has 4 rows of 3 position one-piece fold-down tines
- Roller Bearing™ upper rack has 3 rows of multi-position Hold Tight™ dividers and 1 one-piece cup shelf
- **Exclusive** Diamond-Brite™ stainless steel tank and inner door
- Cycles – Pots/Pans, Normal Wash, Econo Wash, Light/China, Rinse/Hold
- Options – 155°F Final Rinse, Delay Start (up to 6 hours)
- Energy Star Qualified

### Model Options



**VDB325**  
**Professional**  
**Built-In Dishwasher**

Finish details for VDB model

- Stainless Steel (SS), Black (BK), White (WH)





### Dimensions & Specifications

#### PRODUCT DIMENSIONS



**VDB325**  
Professional  
Built-In Dishwasher

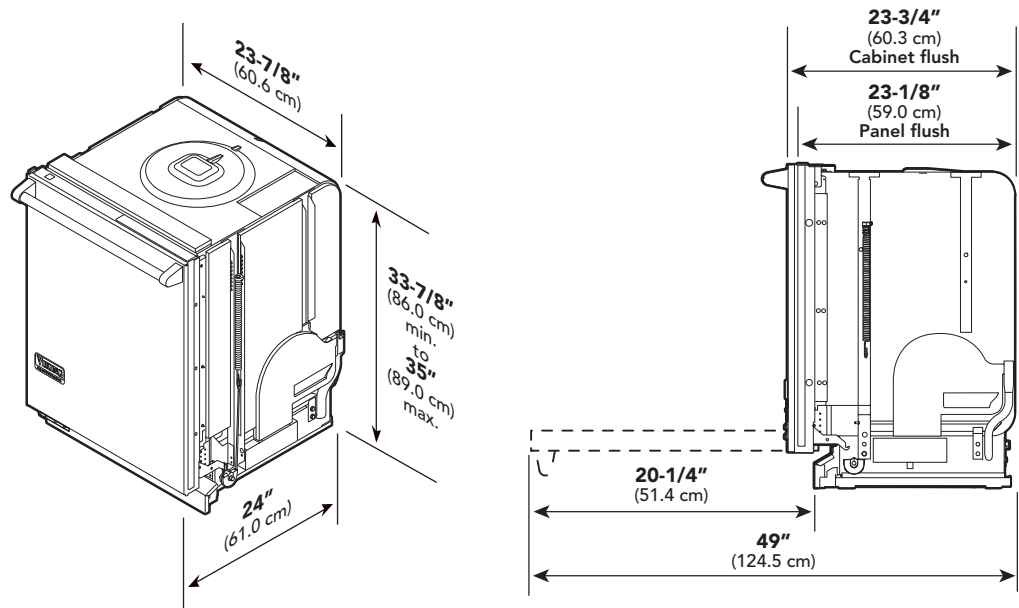

**Note:** If the dishwasher is installed in a corner, there must be a minimum clearance of 2" (5.1 cm) from the side wall so the door can open.

All models	
Overall width	23-7/8" (60.6 cm)
Overall height (from floor)	33-7/8" (86.0 cm) min. to 35" (89.0 cm) max.
Overall depth (from rear)	
To edge of side (includes door panel)	24" (61.0 cm)—includes door panel
With door open	49" (124.5 cm)



### UTILITY REQUIREMENTS



**GAS**  
Not applicable



- ELECTRICAL**
- Five-foot (1.5 m), electrical cord with 90 degree 3-prong plug
  - 120V/60 Hz
  - Maximum amp usage—15.0 amps
  - Water-heating element rating—1,400 watts



- PLUMBING**
- 120°F (49°C) hot water recommended; dishwasher will, however, perform properly with cold water\*
  - Inlet water pressure operating range—10 – 125 psi (0.69 – 8.62 bar)
  - Five foot (1.5 m) braided stainless steel water line with 3/8" (0.95 cm) compression fitting supplied with dishwasher
  - Seven-foot (2.13 m) 1/2" (1.3 cm) ID "crimp-proof" flexible drain hose with clamp attached to dishwasher; connections provided for 5/8" (1.5 cm), 3/4" (1.9 cm), or 1" (2.5 cm) cut as required
  - High loop of drain hose required; min. height from floor—20" (50.8 cm)
  - Check local codes for drain air gap requirement

\*Cycle times will be extended

## Installation Requirements

### ACCESS REQUIREMENTS



**VDB325**  
**Professional**  
**Built-In Dishwasher**

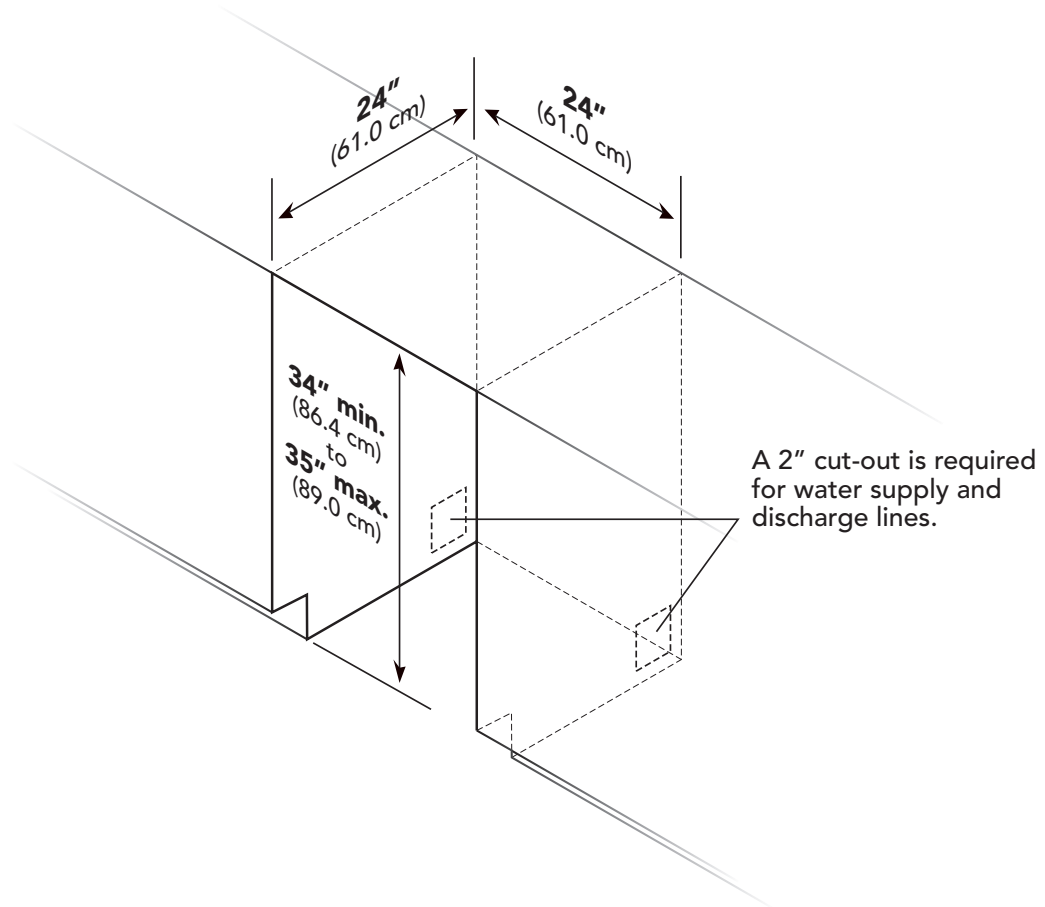

All models	
Cutout width	24" (61.0 cm)
Cutout height	34" (86.4 cm) min. to 35" (89.0 cm) max.
Cutout depth	24" (61.0 cm)



**VIKING**  
DESIGNER

# KITCHEN CLEANUP Built-In 24"W. Dishwasher 325



## Compliance Information



## WARRANTY INFORMATION\*

- One-year full warranty—all components
- Lifetime limited warranty—stainless steel tanks, inner door liner
- Five-year limited warranty—electronic control, racks, motor/pump assemblies, and water distribution system
- Ninety-day limited warranty—cosmetic parts (painted and decorative items)

\*For complete warranty information info see *Use & Care Guide*. Warranty valid on Viking products shipped within the United States and Canada.





# KITCHEN CLEANUP Built-In 24"W. Dishwasher 450



## Standard Features & Accessories

### All models include:

- **Exclusive** Vari-Pressure Intelli-Wash™ System
  - **Exclusive** variable speed 1/2 horsepower commercial-type motor
  - **Exclusive** multi-level washing with two stainless steel wash arms
  - **Exclusive** Block-proof Flexible-Fluid™ coupling direct water feed
- **Exclusive** Central Intelligence™ System
  - Constant communication
  - Measures water temperature and water volume
- **Exclusive** Five-Stage Filtration and Waste Removal System
  - Removable coarse strainer
  - **Exclusive** Triple-Clean™ filtration with self-cleaning jets
  - **Exclusive** ultra hard food waste disposer/motor/pump
- **Exclusive** Sure-Temp™ Water Heating
  - 1400 watt HydroFlo™ water heater
  - Operable with "cold" ground water
- **Air-Flo™** Gentle Drying
  - Gentle, effective and safe heated fan-driven system
  - Fan circulates gentle air over, under and around dishes
- **QuietClean™** Performance Package
  - Separate motor/pump assemblies for washing and draining
  - Multi-stage sound absorbing/heat retaining insulation
  - Blue LED power-on light in kickplate indicates cycle is operating
- "Load-As-You-Like" Versa-Load™ Racks
  - Accommodates 15 international place settings
  - Fully extendable nylon coated racks
  - Two-Piece silverware/cutlery basket
  - Lower rack has 4 rows of 3 position one-piece fold-down tines
- Roller Bearing™ upper rack has 3 rows of multi-position Hold Tight™ dividers, 1 one-piece stemware cradle/cup shelf and 1 one-piece cup shelf
- **Exclusive** Diamond-Brite™ stainless steel tank and inner door
- Cycles – Pots/Pans, Normal Wash, Econo Wash, Light/China, Rinse/Hold
- Options – Econo Dry, 155°F Final Rinse, Top Wash Only, Delay Start (up to 10 hours)
- Energy Star Qualified

## Model Options



**VDB450  
Professional  
Built-In Dishwasher**

- Finish details for VDB model
- Stainless Steel (SS)



**DFB450  
Custom Front  
Built-In Dishwasher**

- Finish details for DFB model
- Handles not included—opt for custom handles or purchase a Viking Professional or Designer handle kit (see **Installation Notes & Accessories**)
  - Door panel not included.\*
  - See **Custom Panels** section for more information and additional specifications.

### ORDERING INSTRUCTIONS

\*Door panel not included. Must order either a Professional w/o louvers (PDDP24), Professional w/louvers (PDDPL24), or Designer (DDDP24) door panel if a custom panel will not be used. Specify color code at end (PDDP24SS). If ordering optional brass trim, specify code at end (PDDP24SSBR). If ordering a custom model (to be fit with a custom panel or with a color panel), use no color or trim code (DFB450).





# KITCHEN CLEANUP Built-In 24"W. Dishwasher 450



★ Please see Installation Notes & Accessories for important installation information, including panel and handle kits.

## Dimensions & Specifications

### PRODUCT DIMENSIONS



**VDB450**  
Professional  
Built-In Dishwasher



**DFB450**  
Custom Front  
Built-In Dishwasher

See Custom Panels section for more information and additional specifications.

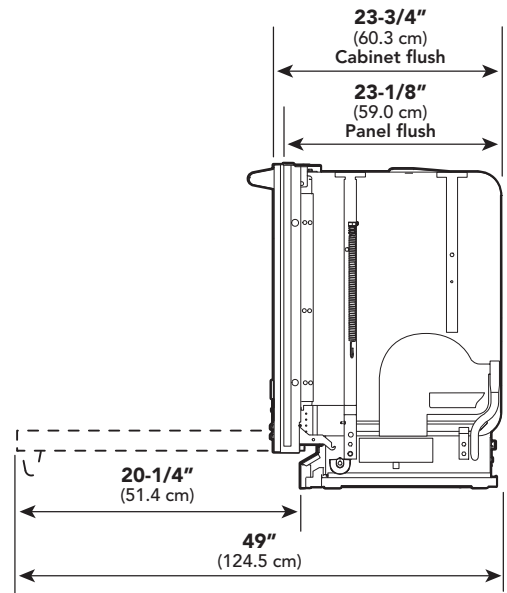
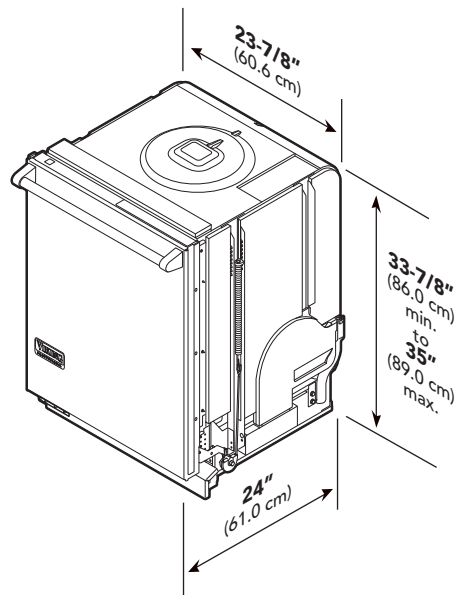

**Note:** If the dishwasher is installed in a corner, there must be a minimum clearance of 2" (5.1 cm) from the side wall so the door can open.

All models	
Overall width	23-7/8" (60.6 cm)
Overall height (from floor)	33-7/8" (86.0 cm) min. to 35" (89.0 cm) max.
Overall depth (from rear)	
To edge of side (includes door panel)	24" (61.0 cm)—includes door panel
With door open	49" (124.5 cm)

**Note:** This unit is NOT designed to be installed without trim. All dimensions include trim.





### UTILITY REQUIREMENTS



**GAS**  
Not applicable



- ELECTRICAL**
- Five-foot (1.5 m), electrical cord with 90 degree 3-prong plug
  - 120V/60 Hz
  - Maximum amp usage—15.0 amps
  - Water-heating element rating—1,400 watts



- PLUMBING**
- 120°F (49°C) hot water recommended; dishwasher will, however, perform properly with cold water\*
  - Inlet water pressure operating range—10 – 125 psi (0.69 – 8.62 bar)
  - Five foot (1.5 m) braided stainless steel water line with 3/8" (0.95 cm) compression fitting supplied with dishwasher
  - Seven-foot (2.13 m) 1/2" (1.3 cm) ID "crimp-proof" flexible drain hose with clamp attached to dishwasher; connections provided for 5/8" (1.5 cm), 3/4" (1.9 cm), or 1" (2.5 cm) cut as required
  - High loop of drain hose required; min. height from floor—20" (50.8 cm)
  - Check local codes for drain air gap requirement

\*Cycle times will be extended

## Installation Requirements

### ACCESS REQUIREMENTS



**VDB450**  
**Professional**  
**Built-In Dishwasher**



**DFB450**  
**Custom Front**  
**Built-In Dishwasher**

See **Custom Panels** section for more information and additional specifications.

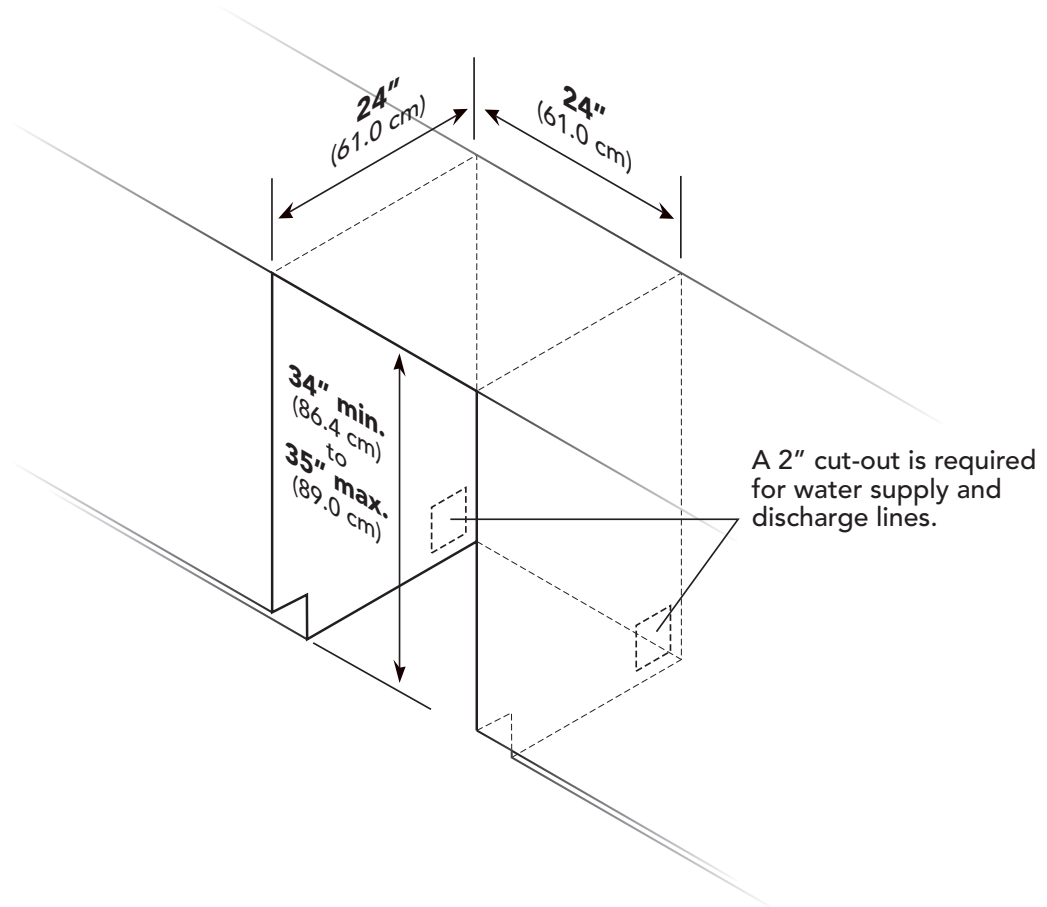

#### All models

Cutout width	24" (61.0 cm)
Cutout height	34" (86.4 cm) min. to 35" (89.0 cm) max.
Cutout depth	24" (61.0 cm)



# KITCHEN CLEANUP Built-In 24"W. Dishwasher 450



## ★ Installation Notes & Accessories

### Door Panel Kits

- For use with DFB450 custom front dishwasher
- Kit includes one panel and installation hardware
- Add **BR** to end of model number for brass trim option

Model	Description	Approx. ship wt. lbs. (kg)
PDDP24-SS	Professional door panel – no louvers (Stainless Steel)	14 (6.3)
PDDP24-BK	Professional door panel – no louvers (Black)	14 (6.3)
PDDP24-WH	Professional door panel – no louvers (White)	14 (6.3)
PDDP24-MS	Professional door panel – no louvers (Metallic Silver)	14 (6.3)
PDDP24-GG	Professional door panel – no louvers (Graphite Gray)	14 (6.3)
PDDP24-SG	Professional door panel – no louvers (Stone Gray)	14 (6.3)
PDDP24-TP	Professional door panel – no louvers (Taupe)	14 (6.3)
PDDP24-BT	Professional door panel – no louvers (Biscuit)	14 (6.3)
PDDP24-CW	Professional door panel – no louvers (Cotton White)	14 (6.3)
PDDP24-OG	Professional door panel – no louvers (Oyster Gray)	14 (6.3)
PDDP24-GM	Professional door panel – no louvers (Golden Mist)	14 (6.3)
PDDP24-LE	Professional door panel – no louvers (Lemonade)	14 (6.3)
PDDP24-SA	Professional door panel – no louvers (Sage)	14 (6.3)
PDDP24-MJ	Professional door panel – no louvers (Mint Julep)	14 (6.3)
PDDP24-SE	Professional door panel – no louvers (Sea Glass)	14 (6.3)
PDDP24-IB	Professional door panel – no louvers (Iridescent Blue)	14 (6.3)
PDDP24-VB	Professional door panel – no louvers (Viking Blue)	14 (6.3)
PDDP24-PM	Professional door panel – no louvers (Pumpkin)	14 (6.3)
PDDP24-RR	Professional door panel – no louvers (Racing Red)	14 (6.3)
PDDP24-AR	Professional door panel – no louvers (Apple Red)	14 (6.3)
PDDP24-BU	Professional door panel – no louvers (Burgundy)	14 (6.3)
PDDP24-PL	Professional door panel – no louvers (Plum)	14 (6.3)
PDDP24-CH	Professional door panel – no louvers (Chocolate)	14 (6.3)
PDDP24-CB	Professional door panel – no louvers (Cobalt Blue)	14 (6.3)
PDDPL24-SS	Professional door panel – louvers (Stainless Steel)	14 (6.3)
DDDP24-SS	Designer door panel (Stainless Steel)	14 (6.3)
DDDP24-BK	Designer door panel (Black)	14 (6.3)
DDDP24-WH	Designer door panel (White)	14 (6.3)
DDDP24-MS	Designer door panel (Metallic Silver)	14 (6.3)
DDDP24-GG	Designer door panel (Graphite Gray)	14 (6.3)
DDDP24-SG	Designer door panel (Stone Gray)	14 (6.3)
DDDP24-TP	Designer door panel (Taupe)	14 (6.3)
DDDP24-BT	Designer door panel (Biscuit)	14 (6.3)
DDDP24-CW	Designer door panel (Cotton White)	14 (6.3)
DDDP24-OG	Designer door panel (Oyster Gray)	14 (6.3)
DDDP24-GM	Designer door panel (Golden Mist)	14 (6.3)
DDDP24-LE	Designer door panel (Lemonade)	14 (6.3)
DDDP24-SA	Designer door panel (Sage)	14 (6.3)
DDDP24-MJ	Designer door panel (Mint Julep)	14 (6.3)
DDDP24-SE	Designer door panel (Sea Glass)	14 (6.3)
DDDP24-IB	Designer door panel (Iridescent Blue)	14 (6.3)
DDDP24-VB	Designer door panel (Viking Blue)	14 (6.3)
DDDP24-PM	Designer door panel (Pumpkin)	14 (6.3)
DDDP24-RR	Designer door panel (Racing Red)	14 (6.3)
DDDP24-AR	Designer door panel (Apple Red)	14 (6.3)
DDDP24-BU	Designer door panel (Burgundy)	14 (6.3)
DDDP24-PL	Designer door panel (Plum)	14 (6.3)
DDDP24-CH	Designer door panel (Chocolate)	14 (6.3)
DDDP24-CB	Designer door panel (Cobalt Blue)	14 (6.3)







# KITCHEN CLEANUP Built-In 24"W. Dishwasher 450



## ★ Installation Notes & Accessories

### Handle Kits

- For use on locally supplied full overlay panels
- Includes handle and installation hardware
- Allows dishwashers with full overlay panel to coordinate with other Professional and Designer products

Model	Description	Approx. ship wt. lbs. (kg)
PHK23-SS	Professional handle (Stainless Steel)	5 (2.3)
PHK23-BR	Professional handle (Brass)	5 (2.3)
DHK20-SS	Designer handle (Stainless Steel)	5 (2.3)
DHK20-BR	Designer handle (Brass)	5 (2.3)

### Compliance Information



### WARRANTY INFORMATION\*

- One-year full warranty—all components
- Lifetime limited warranty—stainless steel tanks, inner door liner
- Five-year limited warranty—electronic control, racks, motor/pump assemblies, and water distribution system
- Ninety-day limited warranty—cosmetic parts (painted and decorative items)

\*For complete warranty information info see *Use & Care Guide*. Warranty valid on Viking products shipped within the United States and Canada.





### Standard Features & Accessories

#### All models include

- Capacity—accommodates 16 international place settings
- Automatic water heating (85°F – 170°F, depending on cycle)
  - 1,200-watt heater
  - Two separate thermostats
- Extremely efficient, energy- and water-saving operation
- Electronic controls offer wash cycles and options that reduce energy costs
  - Cycles: Pots/Pans, Heavy, Normal, Light/China, Quick, Rinse/Hold
  - Options: Temperature Selection, Extra Dry, Five-Hour Delay
  - Controls on inside top of door—hidden when door is closed
- Commercial construction and design
  - Rustproof surgical stainless steel tank/inner door
  - Counterbalanced, heavy-duty door springs
  - Tough, zinc-coated steel frame and one-piece galvanized steel base pan
  - Twin fill valve and overflow protection switch
- Quiet Clean System™ with asphalt, felt, and foam insulation
  - Absorbs sound
  - Retains heat
- Super-extendable graphite nylon racks
  - Adjustable tines
  - Taller upper rack with two dual-level cup racks
  - Silverware/cutlery basket with lidded compartment for small items
- Multi-level wash system
  - Stainless steel lower and upper wash arms turn opposite directions for complete coverage
  - Additional spray zone targets heavily soiled dishes
- Triple filtration and waste removal system
  - Separate motors/pumps for circulation and drain
    - Drains quietly
  - Anti-jam, auto-reversing pump
  - Removable strainer
  - Removable, self-cleaning fine filter captures smaller particles
- Convect-Air™ fan drying safely vents away from controls and cabinets
- Extra-tall tank
  - Eliminates need for top fill strip
  - Allows loading of full-size plates in top rack
- Automatic detergent/rinse agent dispensers
- End of cycle signal
- Shipped with stainless steel door installed, or with **no front**—to accept custom front panel or optional door panel
- Shipped with two stainless steel side trim strips (1/4"W.)

#### Step-up features on 142 models

- Special cradle for long knives and utensils
- Express and Top or Bottom Rack Only cycle options
- Control lock safety feature
- Halogen interior light—turns on when door is opened

### Model Options



**DFUD042/142\***  
Professional

- FINISH DETAILS FOR 042/142 MODELS**
- Stainless Steel (SS), Black (BK), White (WH), Metallic Silver (MS), Graphite Gray (GG), Stone Gray (SG), Taupe (TP), Biscuit (BT), Cotton White (CW), Oyster Gray (OG), Golden Mist (GM), Lemonade (LE), Sage (SA), Mint Julep (MJ), Sea Glass (SE), Iridescent Blue (IB), Viking Blue (VB), Pumpkin (PM), Racing Red (RR), Apple Red (AR), Burgundy (BU), Plum (PL), Chocolate (CH), and Cobalt Blue (CB).
  - Stainless steel handle with chrome-plated brackets.
  - Brass Trim Option (BR)—nameplate and handle/brackets. Brass components have a durable protective coating for maintenance-free normal use.



**DFUD042/142\***  
Designer

- FINISH DETAILS FOR 042/142 MODELS**
- Stainless Steel (SS), Black (BK), White (WH), Metallic Silver (MS), Graphite Gray (GG), Stone Gray (SG), Taupe (TP), Biscuit (BT), Cotton White (CW), Oyster Gray (OG), Golden Mist (GM), Lemonade (LE), Sage (SA), Mint Julep (MJ), Sea Glass (SE), Iridescent Blue (IB), Viking Blue (VB), Pumpkin (PM), Racing Red (RR), Apple Red (AR), Burgundy (BU), Plum (PL), Chocolate (CH), and Cobalt Blue (CB).
  - Cast stainless steel handle.
  - Brass Trim Option (BR)—nameplate and handle. Brass components have a durable protective coating for maintenance-free normal use.



**DFUD042/142**  
Custom Front

- FINISH DETAILS FOR 042/142 MODELS**
- Door not included—opt for a 3/4"-thick custom panel (locally supplied), or purchase a Viking Professional Series or Designer Series door panel kit (see **Installation Notes & Accessories**)
  - Handle not included—opt for a custom handle, or purchase a Viking Professional Series or Designer Series handle kit (see **Installation Notes & Accessories**)
  - See **Custom Panels** section for more information and additional specifications.

\*Shown throughout with door panel. See **Installation Notes & Accessories** for details.

#### ORDERING INSTRUCTIONS

Must order either a Professional (PTD24) or Designer (DTD24) door panel if a custom panel will not be used. Specify color code at end (PTD24SS). If ordering a custom model (to be fit with a custom panel or with a color panel), use no color or trim code (DFUD042).



★ Please see Installation Notes & Accessories for important information, including door panel and handle kits.

## Dimensions & Specifications

### PRODUCT DIMENSIONS



**DFUD042P/142P**  
Professional



**DFUD042D/142D**  
Designer



**DFUD042/142**  
Custom Front

See Custom Panels section for more information and additional specifications.

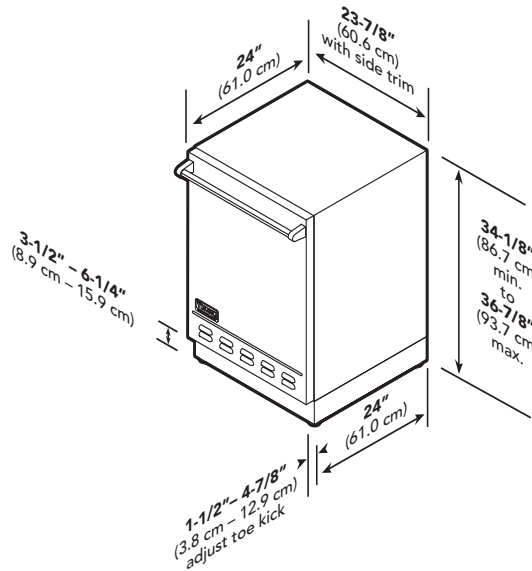

**PROFESSIONAL**

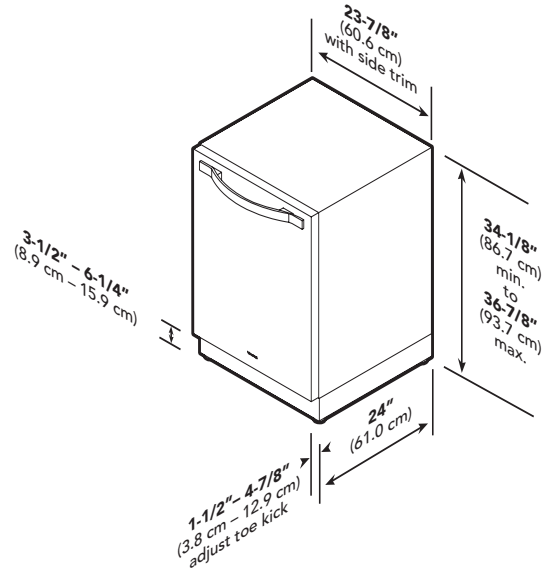

**DESIGNER**

All models	
Overall width	
With side trims	<b>23-7/8" (60.6 cm)</b>
Without side trims	<b>23-1/2" (59.7 cm)</b>
Overall height (from floor)	
With top trim	<b>34-1/8" (86.7 cm) min. to 36-7/8" (93.7 cm) max.</b>
Without top trim	<b>33-3/4" (85.7 cm)</b>
Overall depth (from rear)	
To front edge of side trim	<b>24" (61.0 cm)—includes drain hose + door panel</b>
With door open	<b>49" (124.5 cm)</b>



## Dimensions & Specifications

### DOOR SWING



**DFUD042P/142P**  
Professional



**DFUD042D/142D**  
Designer



**DFUD042/142**  
Custom Front

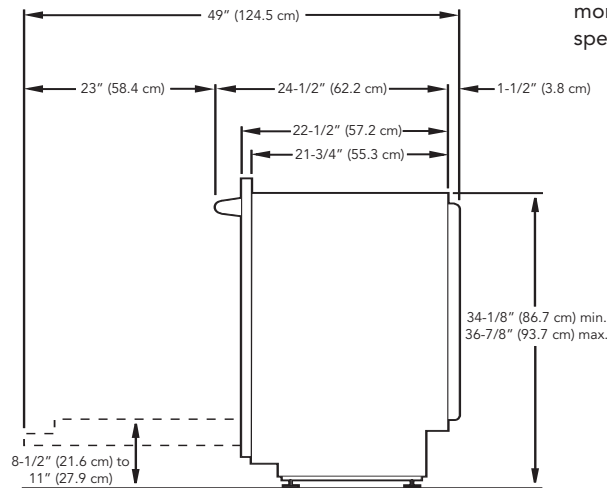

See **Custom Panels** section for more information and additional specifications.

### PROFESSIONAL

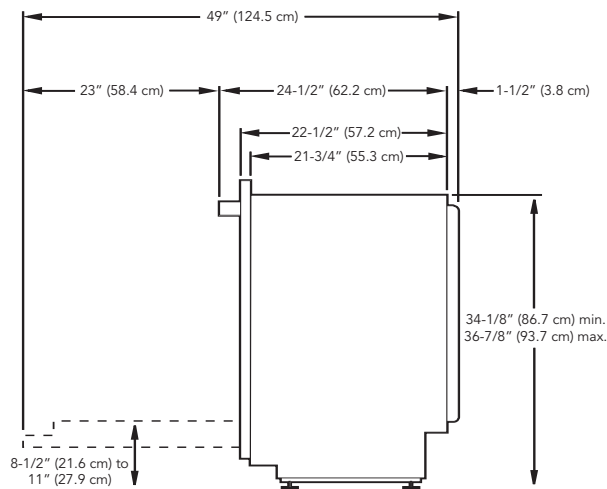

### DESIGNER

**Note:** If the dishwasher is installed in a corner, there must be a minimum clearance of 2" (5.1 cm) from the side wall so the door can open.



## UTILITY REQUIREMENTS



### GAS

Not applicable



### ELECTRICAL

- 6' (1.8 m), two-wire cord with grounded, three-prong plug supplied with unit
- 120 VAC/60 Hz
- Maximum amp usage—15.0
- Water-heating element rating—1,200 watts



### PLUMBING

- 120°F (49°C) hot water recommended; dishwasher will, however, perform properly with cold water (Cycle times will vary)
- Inlet water pressure operating range—18 – 176 psi (125 – 1,227 kPa)
- 6-1/2' (2.0 m) 3/4" (1.9 cm) ID "crimp-proof" rubber drain hose with clamp attached to dishwasher; can be extended up to a maximum of 10' (3.0 m) with 3/4" (1.9 cm) ID copper tubing
- High loop of drain hose required; min. height from floor—24" (61.0 cm); max. height—35" (88.9 cm)
- 6' (1.8 m) PEX water line with 3/8" (0.95 cm) compression fitting (NPT female connection) supplied with unit
- Check local codes for drain air gap requirement

## Installation Requirements

### ACCESS REQUIREMENTS



DFUD042P/142P  
Professional



DFUD042D/142D  
Designer



DFUD042/142  
Custom Front

See **Custom Panels** section for more information and additional specifications.

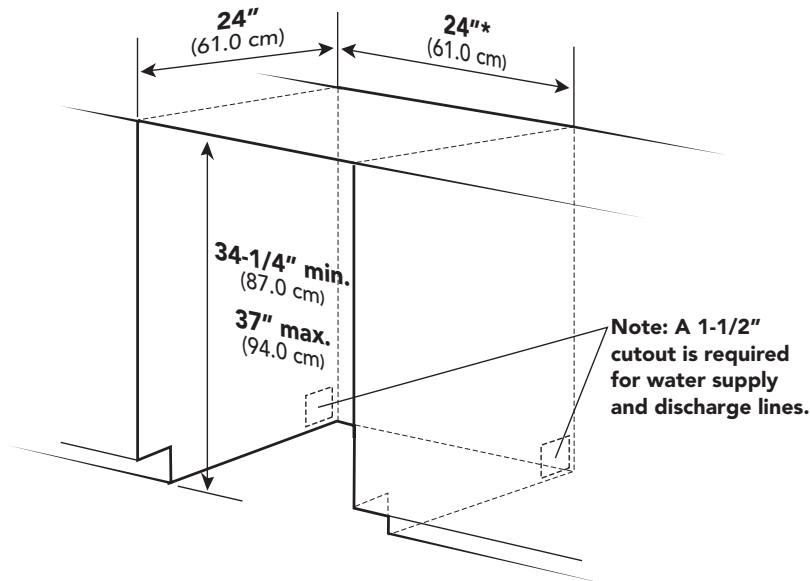

\*When installing the dishwasher without the side trim, the cutout must be 23-5/8" (60.0 cm), and approximately 4" (10.2 cm) of the inside cabinets must be finished.

#### All models

Cutout width	24" (61.0 cm)
Cutout height	34-1/4" (87.0 cm) min. to 37" (94.0 cm) max.
Cutout depth	24" (61.0 cm)



# KITCHEN CLEANUP Undercounter 24"W. Dishwasher



## ★ Installation Notes & Accessories

### Door Panel Kits

- For use with DFUD042/142 custom front dishwasher
- Kit includes one panel and installation hardware
- Add **BR** to end of model number for brass trim option

Model	Description	Approx. ship wt. lbs. (kg)
PTD24-SS	Professional door panel (Stainless Steel)	14 (6.3)
PTD24-BK	Professional door panel (Black)	14 (6.3)
PTD24-WH	Professional door panel (White)	14 (6.3)
PTD24-AL	Professional door panel (Almond)	14 (6.3)
PTD24-BT	Professional door panel (Biscuit)	14 (6.3)
PTD24-SG	Professional door panel (Stone Gray)	14 (6.3)
PTD24-GG	Professional door panel (Graphite Gray)	14 (6.3)
PTD24-BU	Professional door panel (Burgundy)	14 (6.3)
PTD24-LE	Professional door panel (Lemonade)	14 (6.3)
PTD24-MJ	Professional door panel (Mint Julep)	14 (6.3)
PTD24-FG	Professional door panel (Forest Green)	14 (6.3)
PTD24-VB	Professional door panel (Viking Blue)	14 (6.3)
PTD24-CB	Professional door panel (Cobalt Blue)	14 (6.3)
PTD24-EP	Professional door panel (Eggplant)	14 (6.3)
DTD24-SS	Designer door panel (Stainless Steel)	14 (6.3)
DTD24-BK	Designer door panel (Black)	14 (6.3)
DTD24-WH	Designer door panel (White)	14 (6.3)
DTD24-BT	Designer door panel (Biscuit)	14 (6.3)
DTD24-SG	Designer door panel (Stone Gray)	14 (6.3)
DTD24-GG	Designer door panel (Graphite Gray)	14 (6.3)

### Handle Kits

- For use with DFUD042/142 custom front dishwasher
- Handle allows dishwashers with custom door panel to coordinate with the Professional and Designer products
- Kit includes one handle and installation hardware

Model	Description	Approx. ship wt. lbs. (kg)
PHK23-SS	Professional handle (Stainless Steel)	5 (2.3)
PHK23-BR	Professional handle (Brass)	5 (2.3)
DHK20-SS	Designer handle (Stainless Steel)	5 (2.3)
DHK20-BR	Designer handle (Brass)	5 (2.3)

### Compliance Information



### WARRANTY SUMMARY\*

- One-year full warranty—all components
- Twenty-five-year limited warranty—stainless steel tank, inner door liner
- Five-year limited warranty—racks, motors/pumps assemblies (2), and water distribution system
- Ninety-day limited warranty—cosmetic parts (painted and decorative items)

\*For complete warranty see *Use & Care Guide*. Warranty valid on Viking products shipped within the United States and Canada.





# KITCHEN CLEANUP

## Undercounter 18"W. Trash Compactor



### Standard Features & Accessories

#### All models include

- Trash drawer capacity—1.7 cu. ft.—the largest capacity trash drawer on the market
  - Allows random loading of bulky items
- Machine easily compacts and holds the weekly trash of a family of four
- Commercial-type construction—the most powerful home compactor
- Professional styling
- Built-in small litter area
  - Allows loading of small items without opening large drawer
  - May be opened during operation
- Built-in storage compartment
- Easy-glide drawer allows for smooth opening and closing
- Breakaway trash basket with pressure release handle/plate for easy removal
  - Easy to empty and clean
  - May be used with or without bags
- Activated charcoal filter and fan with control panel switch (shipped with one filter)
  - Removes odors
  - Eliminates the need for perfumed deodorizers
  - A control panel light indicates fan is operating
- 1/2 horsepower, high-torque motor with 3,000 lbs. of force (delivered at all positions and at all points of the ram head)
- 3-Point Drive System avoids jamming, which can result from uneven loading
  - In 35 seconds, this system reduces trash to 1/4 its original size
- 3-Piece Ram encloses motor and drive system, for quiet operation
- Durable, heavy-gauge steel frame and double-reinforced base withstand heavy loads
- Key-start operation with safety lock
  - Positive drawer closing—compactor will not operate while drawer is open
- Shipped with five grip/slip plastic bags with ties
  - Outside grips to hold bag in place; inside slips for easy compacting
  - Specifically designed to fit 18"W. compactor
  - A tough 3.5 mil. thick
  - Punched holes match bag retainer buttons

### Model Options



**VUC181**  
Professional

#### FINISH DETAILS FOR VUC MODEL

- Stainless Steel (SS), Black (BK), White (WH), Metallic Silver (MS), Graphite Gray (GG), Stone Gray (SG), Taupe (TP), Biscuit (BT), Cotton White (CW), Oyster Gray (OG), Golden Mist (GM), Lemonade (LE), Sage (SA), Mint Julep (MJ), Sea Glass (SE), Iridescent Blue (IB), Viking Blue (VB), Pumpkin (PM), Racing Red (RR), Apple Red (AR), Burgundy (BU), Plum (PL), Chocolate (CH), and Cobalt Blue (CB).
- Finish designates door and drawer panels. Stainless steel control panel (with black graphics), litter door pull, handle (with chrome-plated brackets); black control panel switches.
- Brass Trim Option (BR)—nameplate, handle/brackets, and litter door pull. Brass components have a durable protective coating for maintenance-free normal use.



**DUC180**  
Designer

#### FINISH DETAILS FOR DUC MODEL

- Stainless Steel (SS), Black (BK), White (WH), Metallic Silver (MS), Graphite Gray (GG), Stone Gray (SG), Taupe (TP), Biscuit (BT), Cotton White (CW), Oyster Gray (OG), Golden Mist (GM), Lemonade (LE), Sage (SA), Mint Julep (MJ), Sea Glass (SE), Iridescent Blue (IB), Viking Blue (VB), Pumpkin (PM), Racing Red (RR), Apple Red (AR), Burgundy (BU), Plum (PL), Chocolate (CH), and Cobalt Blue (CB).
- Finish designates door and control panel. Cast stainless steel handle.
- Brass Trim Option (BR)—handle and release lever. Brass components have a durable protective coating for maintenance-free normal use.



**DFC180**  
Custom Front

#### FINISH DETAILS FOR DFC MODEL

- Stainless Steel control panel.
- Handle not included—opt for a custom handle, or purchase a Viking Professional Series or Designer Series handle kit (see **Installation Notes & Accessories**)
- Accepts 3/4"-thick custom panel
- See **Custom Panels** section for more information and additional specifications.

#### ORDERING INSTRUCTIONS

First specify model number, followed by color code (VUC181**SS**). If ordering optional brass trim, specify code at end (VUC181**SSBR**).





# KITCHEN CLEANUP Undercounter 18"W. Trash Compactor



★ Please see Installation Notes & Accessories for important information, including handle kits, bags/ties, and filters.

## Dimensions & Specifications

### PRODUCT DIMENSIONS



**VUC181**  
Professional



**DUC180**  
Designer



**DFC180**  
Custom Front

See Custom Panels section for more information and additional specifications.

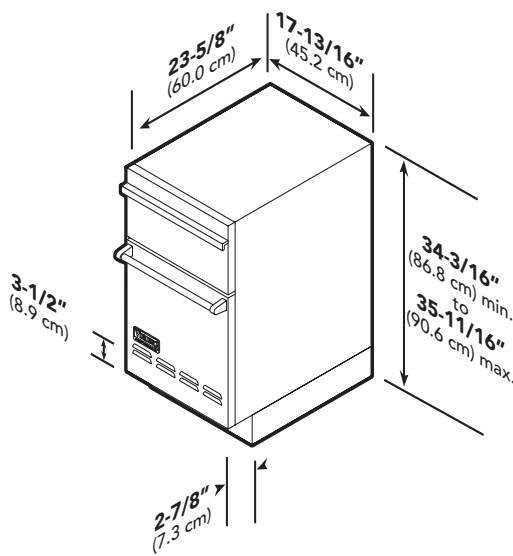

**PROFESSIONAL**

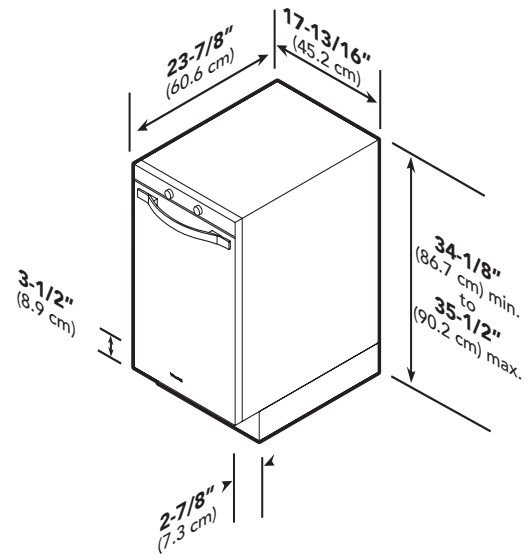

**DESIGNER**

	<b>VUC181</b>	<b>DUC180</b>	<b>DFC180</b>
Overall width		<b>17-13/16" (45.2 cm)</b>	
Overall height	34-3/16" (86.8 cm) min. to 35-11/16" (90.6 cm) max.	34-1/8" (86.7 cm) min. to 35-1/2" (90.2 cm) max.	34-1/8" (86.7 cm) min. to 35-1/2" (90.2 cm) max.
Overall depth			
To edge of side (includes door panel)	23-5/8" (60.0 cm)	23-7/8" (60.6 cm)	23-7/8" (60.6 cm)
With door open	48-1/8" (122.2 cm)	45-3/4" (109.8 cm)	45-3/4" (109.8 cm)







# KITCHEN CLEANUP Undercounter 18"W. Trash Compactor



## Dimensions & Specifications

### DOOR SWING



**VUC181**  
Professional



**DUC180**  
Designer



**DFC180**  
Custom Front

See **Custom Panels** section for more information and additional specifications.

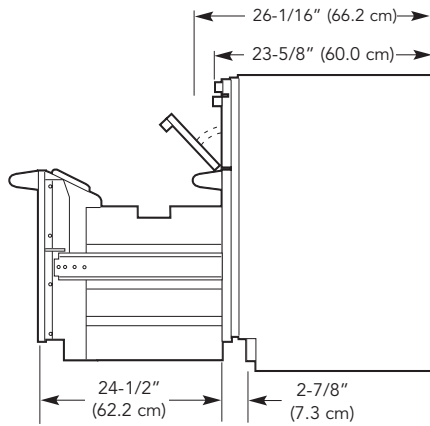

**PROFESSIONAL**

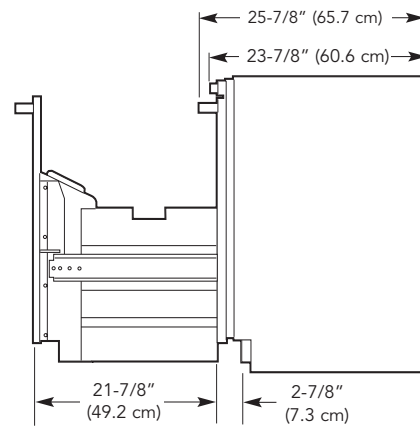

**DESIGNER**

### CLEARANCE DIMENSIONS

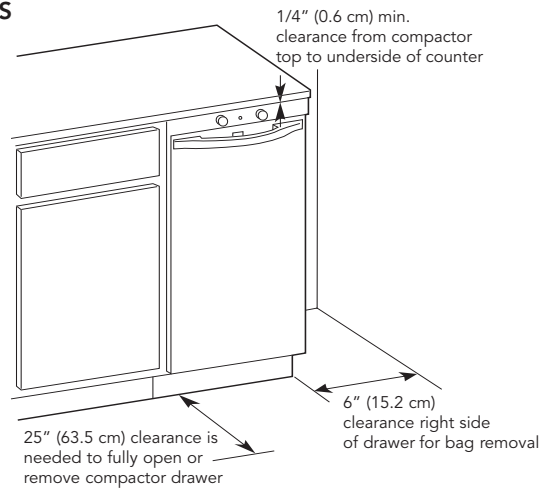



### UTILITY REQUIREMENTS



**GAS**  
Not applicable



**ELECTRICAL**

- 72" (182.9 cm) three-wire cord with grounded, three-prong plug supplied with unit (bracket to end—54", 137.2 cm)
- 115 VAC/60 Hz
- Maximum amp usage—9.0



**PLUMBING**  
Not applicable

## Installation Requirements

### ACCESS REQUIREMENTS



**VUC181**  
Professional



**DUC180**  
Designer



**DFC180**  
Custom Front

See **Custom Panels** section for more information and additional specifications.

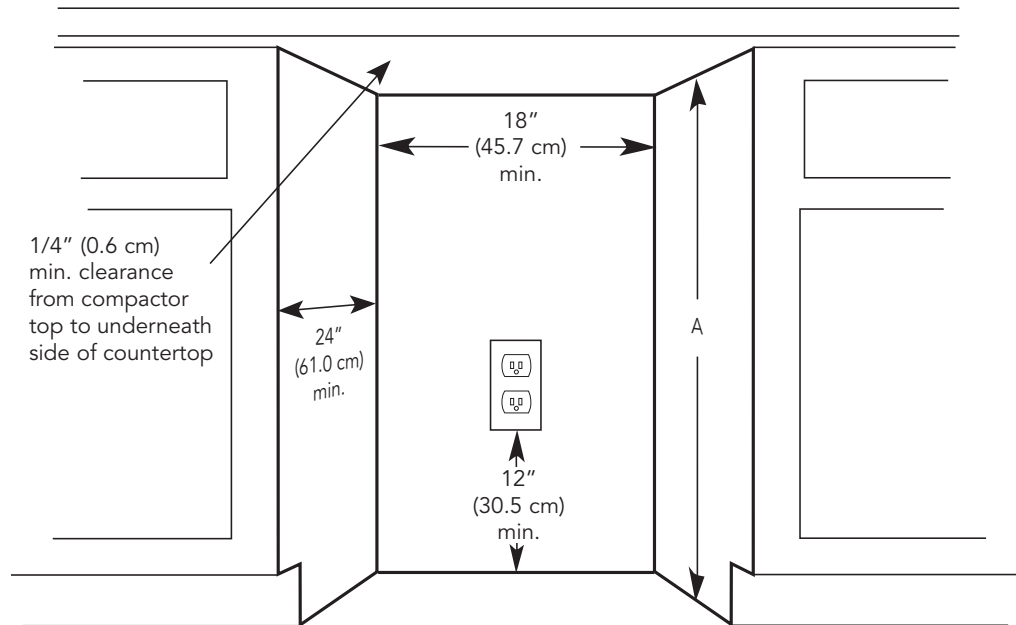

	VUC181	DUC180	DFC180
Cutout width		<b>18" (45.7 cm) min.</b>	
Cutout height (A)	34-7/16" (87.5 cm) min. to 35-15/16" (91.3 cm) max.	34-3/8" (86.4 cm) min. to 35-3/4" (90.8 cm) max.	34-3/8" (86.4 cm) min. to 35-3/4" (90.8 cm) max.
Cutout depth		<b>24" (61.0 cm) min.</b>	



# KITCHEN CLEANUP Undercounter 18"W. Trash Compactor



## ★ Installation Notes & Accessories

### Handle Kits

- For use with full overlay compactor
- For use on locally supplied custom panels
- Handle allows compactors with full overlay panel to coordinate with other Professional and Designer products
- Kit includes one handle and installation hardware

Model	Description	Approx. ship wt. lbs. (kg)
PHK17-SS	Professional handle (Stainless Steel)	2 (0.9)
PHK17-BR	Professional handle (Brass)	2 (0.9)
DHK17-SS	Designer handle (Stainless Steel)	2 (0.9)
DHK17-BR	Designer handle (Brass)	2 (0.9)

### Bags & Ties

- Specifically designed to fit 18"W. compactor
- Outside grips to hold bag in place; inside slips for easy compacting
- Punched holes match retainer buttons
- Bags are 3.5 mil. thick
- Fifteen of each per box (twelve boxes per order)

Model	Description	Approx. ship wt. lbs. (kg)
TCBC15-VUC	Compactor bags/ties	38 (17.1)

### Charcoal Filter

- Activated charcoal captures and removes odors, as opposed to a perfumed approach
- To be replaced every six to nine months (one filter shipped with product)

Model	Description	Approx. ship wt. lbs. (kg)
ACF-VUC	Charcoal filter	1 (0.5)

### Compliance Information



### WARRANTY SUMMARY\*

- One-year full warranty—complete compactor
- Twenty-five-year limited warranty—stainless steel tank/inner door liner
- Five-year limited warranty—1/2 horsepower drive system motor
- Ninety-day limited warranty—cosmetic parts (painted and decorative items)

\*For complete warranty see *Use & Care Guide*. Warranty valid on Viking products shipped within the United States and Canada.





**VIKING**  
DESIGNER

# KITCHEN CLEANUP Heavy-Duty Food Waste Disposer



## Standard Features & Accessories

### Both models include

- Capacitor start motor is one of most powerful residential motors available
- Convenient wall switch start
  - Operates with or without cover for easy loading of food waste
- Super-quiet operation
  - Sound-absorbing, grind-area insulation
  - Six isolating gaskets in key operating areas for sound absorption and reduced vibration
  - Quiet, efficient fixed impellers eliminate noise generated by ordinary swivel blades and will not swing away from waste
- Durable components
  - Stainless steel corrosion-resistant upper housing
  - Cast aluminum drain chamber with protective polymer shield
  - Permanently lubricated primary bronze bearing
- Quick groove-twist lock installation makes it easy to install, or to replace your old disposer
- Anti-jam auto reversing
  - Grind wheel moves in opposite direction with each start, breaking the jams that stop ordinary disposers
  - Reverse action doubles cutter life
- Exclusive grind system
  - Solid cast grind wheel
  - Two fixed stainless steel impellers for quick, quiet grinding
  - Continuous cutting from 18 uppercutters and 16 undercutters
  - Precision balanced for smooth, vibration-free performance
- Solid cast shredder ring
  - 45 double-edge cutters
  - **Exclusive**—1.4 million uppercuttings and 1.3 million undercuttings per minute (15 times that of the nearest high-end competitor)
- Highly effective for use with septic tanks

## Model Options



**VCFW750**  
3/4 HP

### 3/4 HP CONTINUOUS FEED DISPOSER

#### INCLUDES

- 3/4 horsepower motor
- Seven-year full warranty



**VCFW1000**  
1 HP

### 1 HP CONTINUOUS FEED DISPOSER

#### INCLUDES

- 1 horsepower motor
- Ten-year full warranty
- **Exclusive** Power Plus Jam-inator® button—this solid-state device causes the grind wheel to oscillate approx. 7,000 times per minute, pulverizing even the toughest jams.





## UTILITY REQUIREMENTS



### GAS

Not applicable



### ELECTRICAL

- Hard wire direct with two-wire with ground
- 120 VAC/60 Hz
- Maximum amp usage—
  - o 750—8.0
  - o 1000—10.0



### PLUMBING

- Shipped with 1-1/2" OD waste line spout with gasket and 7/8" OD dishwasher connect tube

## Dimensions & Specifications

### PRODUCT DIMENSIONS



VCFW750



VCFW1000

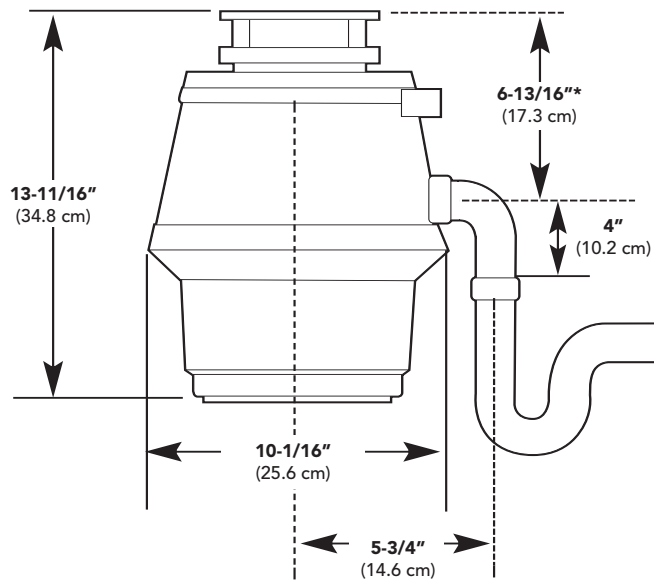

**Note:** Centerline of disposer discharge to centerline at waste pipe entering wall—must be greater than 1/4" (0.6 cm) to prevent standing water in disposer.

\*Add 1/2" (1.3 cm) when stainless steel sink is used.

#### All models

Overall width	10-1/16" (25.6 cm)
Overall height	13-11/16" (34.8 cm)
Overall depth	10-1/16" (25.6 cm)



# KITCHEN CLEANUP Heavy-Duty Food Waste Disposal



## ★ Installation Notes & Accessories

### Batch Feed Accessory Kit

- Kit converts a continuous feed disposer into magnetically activated batch feed unit

Model	Description	Approx. ship wt. lbs. (kg)
BFAK	Batch feed converter	3 (1.4)

### Counter/Sink Switch Kit

- Easily mounts to sink or countertop
- Perfect for island installations
- Air-activated
- Provides extra outlet
- Kit includes chrome and white buttons

Model	Description	Approx. ship wt. lbs. (kg)
STSK	Counter/sink switch	2 (0.9)

### Sink Stopper

- Available in Brass (BR), White (WH), and Biscuit (BT), to coordinate with sink flanges
- Master pack of five

Model	Description	Approx. ship wt. lbs. (kg)
SSTP5	Sink stoppers	5 (2.3)

### Sink Flange

- Available in Brass (BR), White (WH), and Biscuit (BT)
- Master pack of five

Model	Description	Approx. ship wt. lbs. (kg)
SFLG5	Sink flanges	5 (2.3)

### Deep Sink Flange

- Available in Stainless Steel (SS)
- Accommodates up to 1-3/4"-thick sinks (farmhouse style)
- Master pack of five

Model	Description	Approx. ship wt. lbs. (kg)
SFLGD5	Deep sink flanges	6 (2.7)

### Compliance Information



### WARRANTY SUMMARY\*

- Ten-year full warranty for 1000 model—covers complete disposer
- Seven-year full warranty for 750 model
- Ninety-day limited warranty—cosmetic parts (painted and decorative items)

\*For complete warranty see *Use & Care Guide*. Warranty valid on Viking products shipped within the United States and Canada.

