

KitchenAid® DOOR AND PANEL PARTS

For Models: KUDT03FPA2
(Panel Ready)

UNDERCOUNTER
DISHWASHER

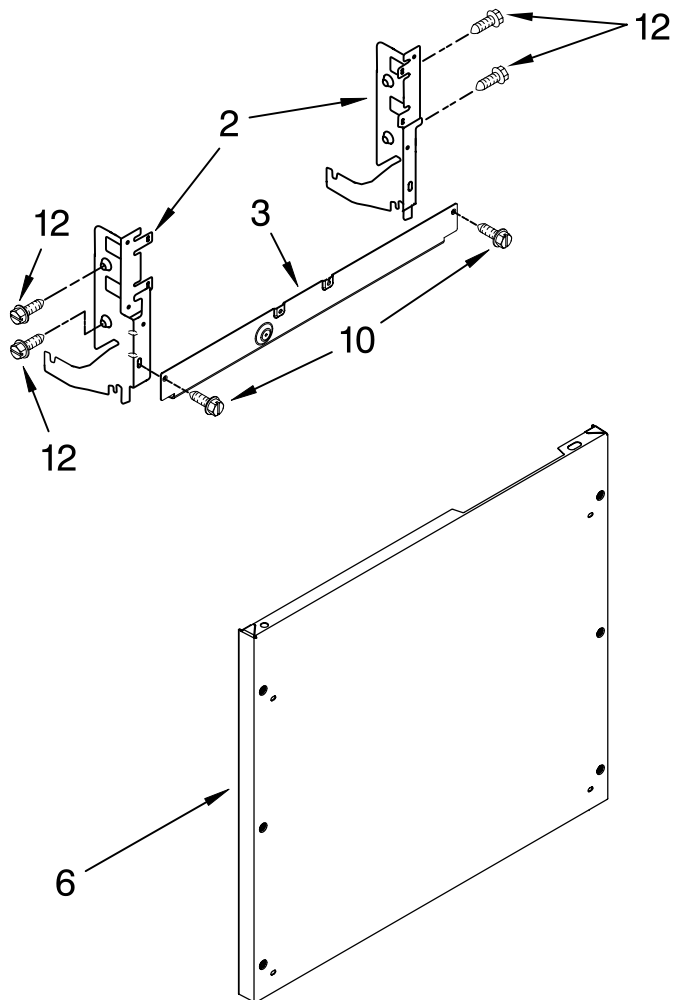

Illus. No.	Part No.	DESCRIPTION
1	W10078153	Literature Parts Instructions, Installation
	W10111124	Energy Guide
	W10084169	D/W User Instructions, Spanish
	W10084091	D/W User Instructions, English/French
	W10082651	Tech Sheet
2		Arm, Hinge
	8534854	Left
	8534853	Right
3	8564886	Stiffener, Door
4	8531882	Screws, Bag Door Assembly
5	8558260	Access Panel (Includes Item 11)
6	8535133	Panel, Full Front
7	8558252	Toe Panel (Includes Items 8 & 13)
8	W10073550	Insulation, Toe Panel
9	302868	Screw
10	304392	Screw
11	W10073540	Insulation, Access Panel
12	3400071	Screw
13	8269016	Clip, Grounding

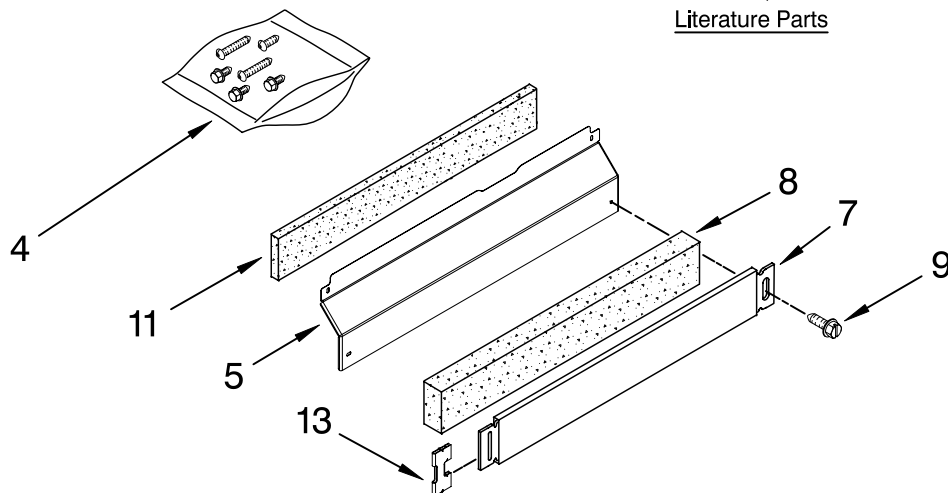
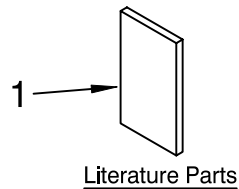

FOR ORDERING INFORMATION REFER TO PARTS PRICE LIST

CONTROL PANEL PARTS

For Models: KUDT03FTP A2
(Panel Ready)

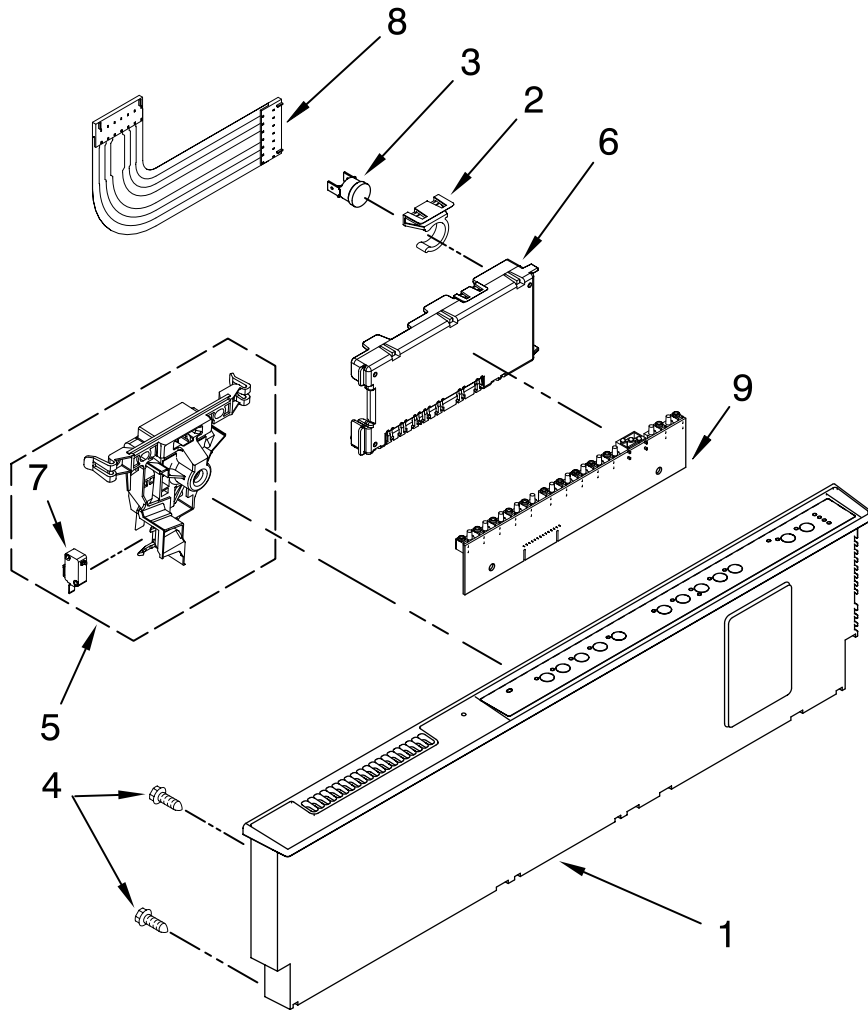

Illus. No.	Part No.	DESCRIPTION
1	W10084183	Console Assembly (Includes Insert)
2	8546546	Clip, Bi-Metal
3	661663	Bi-Metal
4	3369051	Screw
5	W10077360	Latch Assembly
6	W10084141	Control, Electronic
7	W10134019	Switch, Door
8	8524447	Cabel, Ribbon
9	W10111537	User Interface

FOR ORDERING INFORMATION REFER TO PARTS PRICE LIST

DOOR AND LATCH PARTS

For Models: KUDT03FPA2
(Panel Ready)

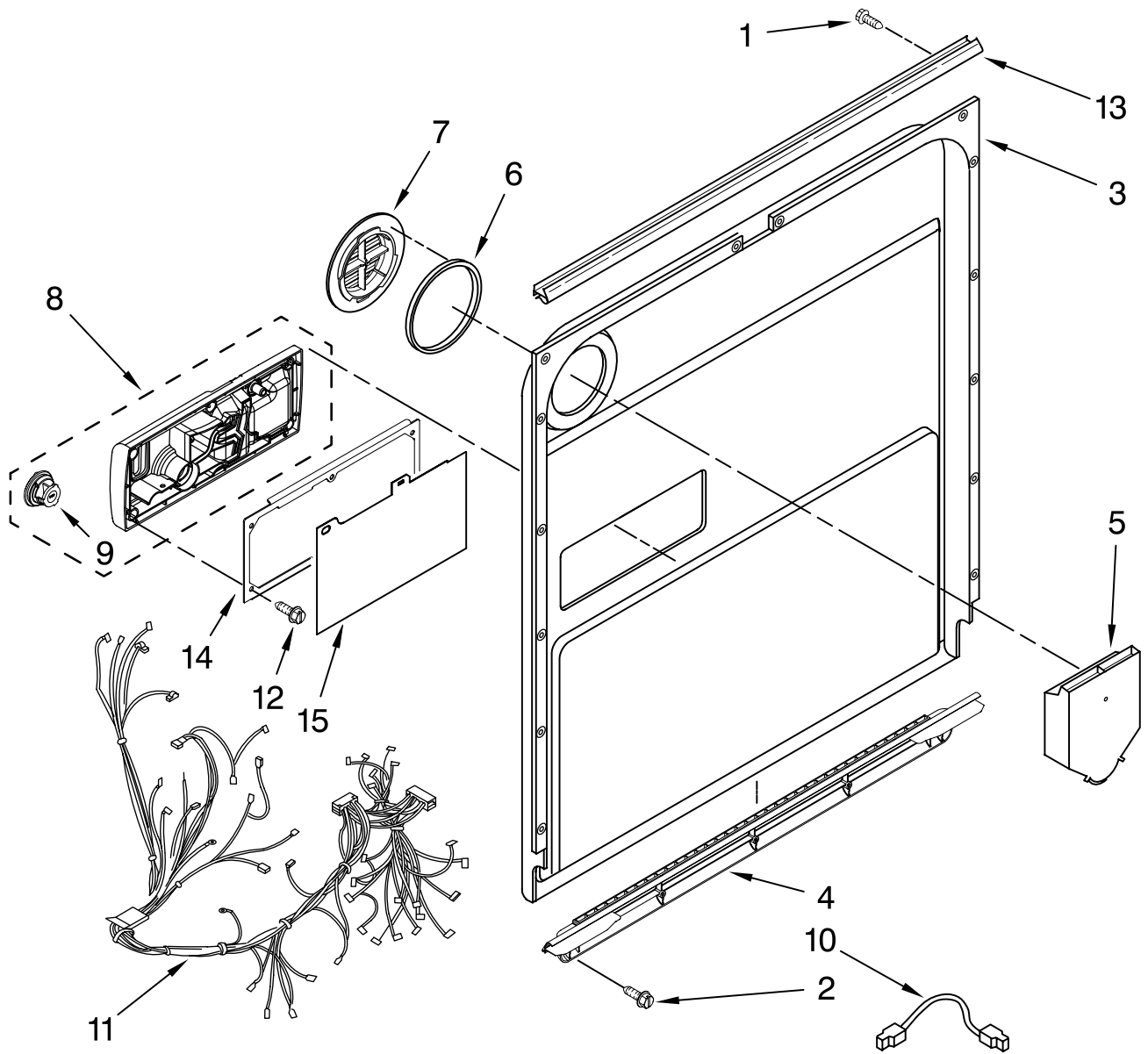

Illus. No.	Part No.	DESCRIPTION
1	3369051	Screw, Door
2	8281217	Screw
3	W10084288	Inner Door Mastic Assembly (Also Order Item 6)
4	W10077883	Inlet, Air
5	8572611	Vent Assembly (Also Order Item 6)

Illus. No.	Part No.	DESCRIPTION
6	8269259	Gasket, Vent
7	W10077877	Deflector, Vent (Also Order Item 6)
8	W10077882	Dispenser, Assembly
9	W10077881	Knob, Rinse Aid
10	8545608	Harness, Vent Motor

Illus. No.	Part No.	DESCRIPTION
11	W10078202	Wiring Harness
12	8281154	Screw
13	8535660	Seal, Console/door
14	8535637	Bracket, Dispenser
15	8531865	Shield, Dispenser

FOR ORDERING INFORMATION REFER TO PARTS PRICE LIST

LOWER WASHARM AND STRAINER PARTS

For Models: KUDT03FTP A2
(Panel Ready)

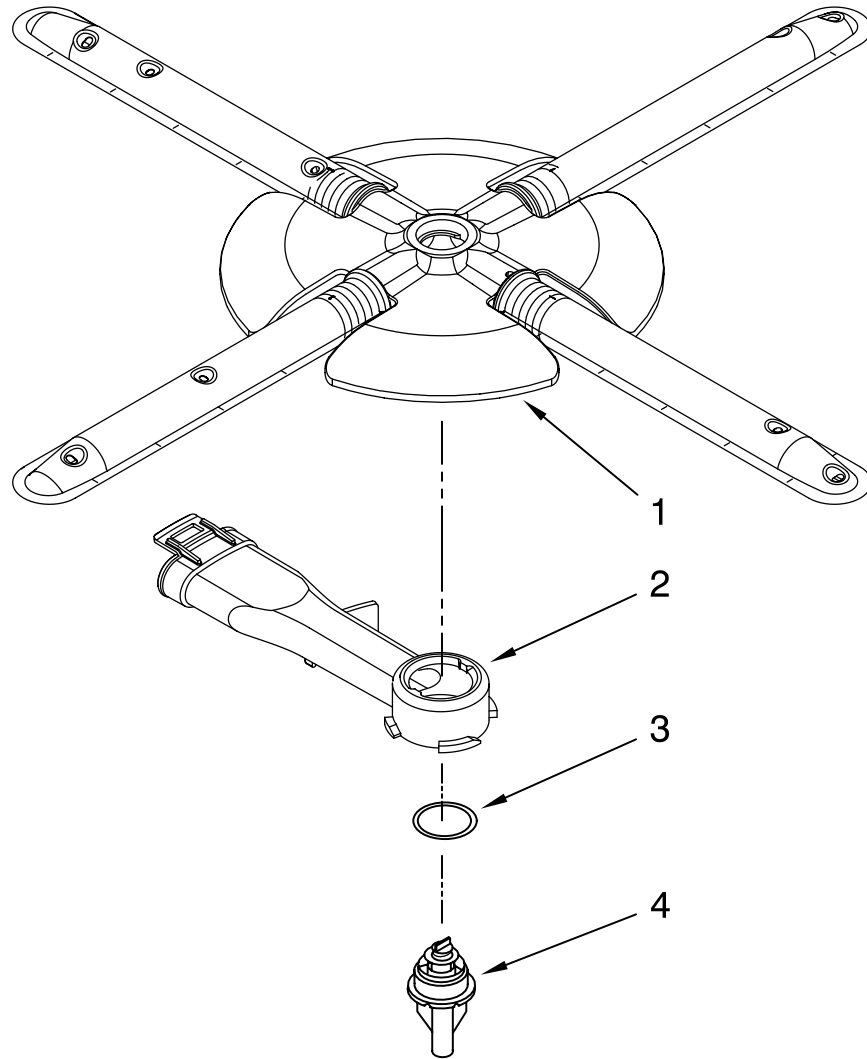

Illus. No.	Part No.	DESCRIPTION
1	W10077965	Wash Arm Assembly
2	W10077899	Cap, Internal Rear Feed (Also Order Item 3)
3	8268340	Seal, Sprayarm
4	W10077898	Hub, Lower Sprayarm (Also Order Item 3)

FOR ORDERING INFORMATION REFER TO PARTS PRICE LIST

HEATER PARTS

For Models: KUDT03FTP A2
(Panel Ready)

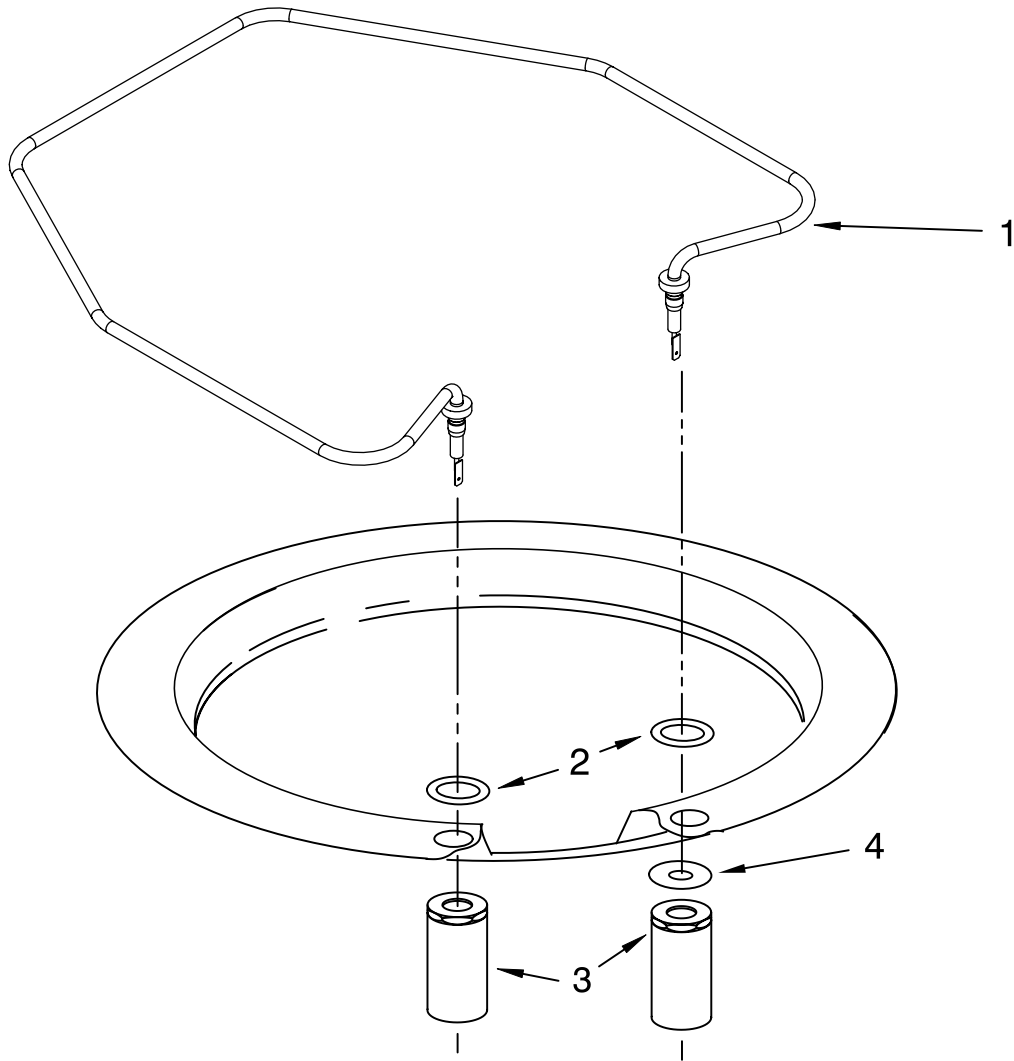

Illus. No.	Part No.	DESCRIPTION
1	8537057	Heater Element Assembly (Also Includes Item 2)
2	717273	Washer, Heater Element
3	8268548	Nut, Heater Element
4	3400931	Retainer, Spring Grip

NOTE: If heater element is removed, it must be replaced.

FOR ORDERING INFORMATION REFER TO PARTS PRICE LIST

FILL, DRAIN, AND OVERFILL PARTS

For Models: KUDT03FTP A2
(Panel Ready)

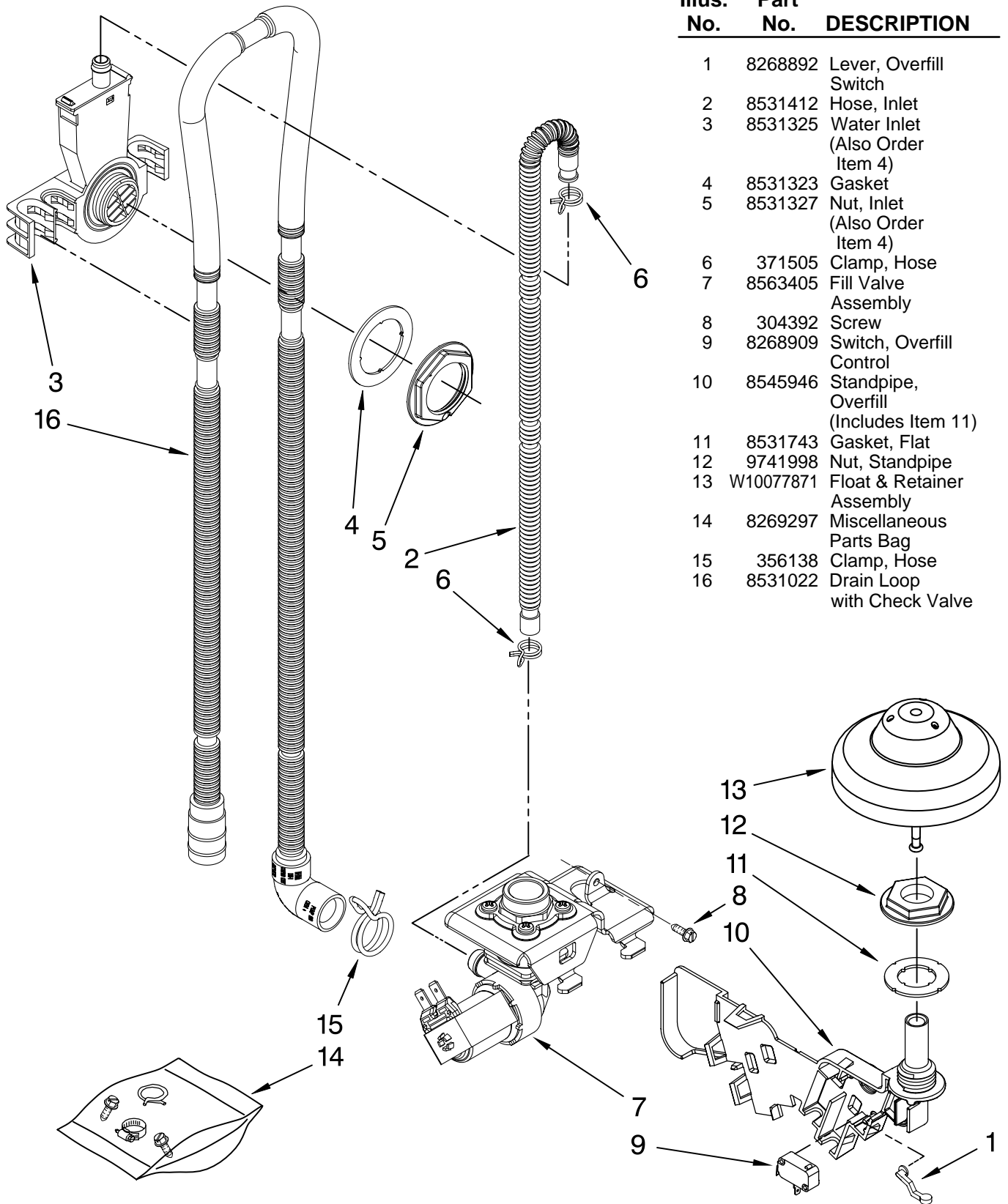

Illus. No.	Part No.	DESCRIPTION
1	8268892	Lever, Overfill Switch
2	8531412	Hose, Inlet
3	8531325	Water Inlet (Also Order Item 4)
4	8531323	Gasket
5	8531327	Nut, Inlet (Also Order Item 4)
6	371505	Clamp, Hose
7	8563405	Fill Valve Assembly
8	304392	Screw
9	8268909	Switch, Overfill Control
10	8545946	Standpipe, Overflow (Includes Item 11)
11	8531743	Gasket, Flat
12	9741998	Nut, Standpipe
13	W10077871	Float & Retainer Assembly
14	8269297	Miscellaneous Parts Bag
15	356138	Clamp, Hose
16	8531022	Drain Loop with Check Valve

FOR ORDERING INFORMATION REFER TO PARTS PRICE LIST

TUB AND FRAME PARTS

For Models: KUDT03FPA2
(Panel Ready)

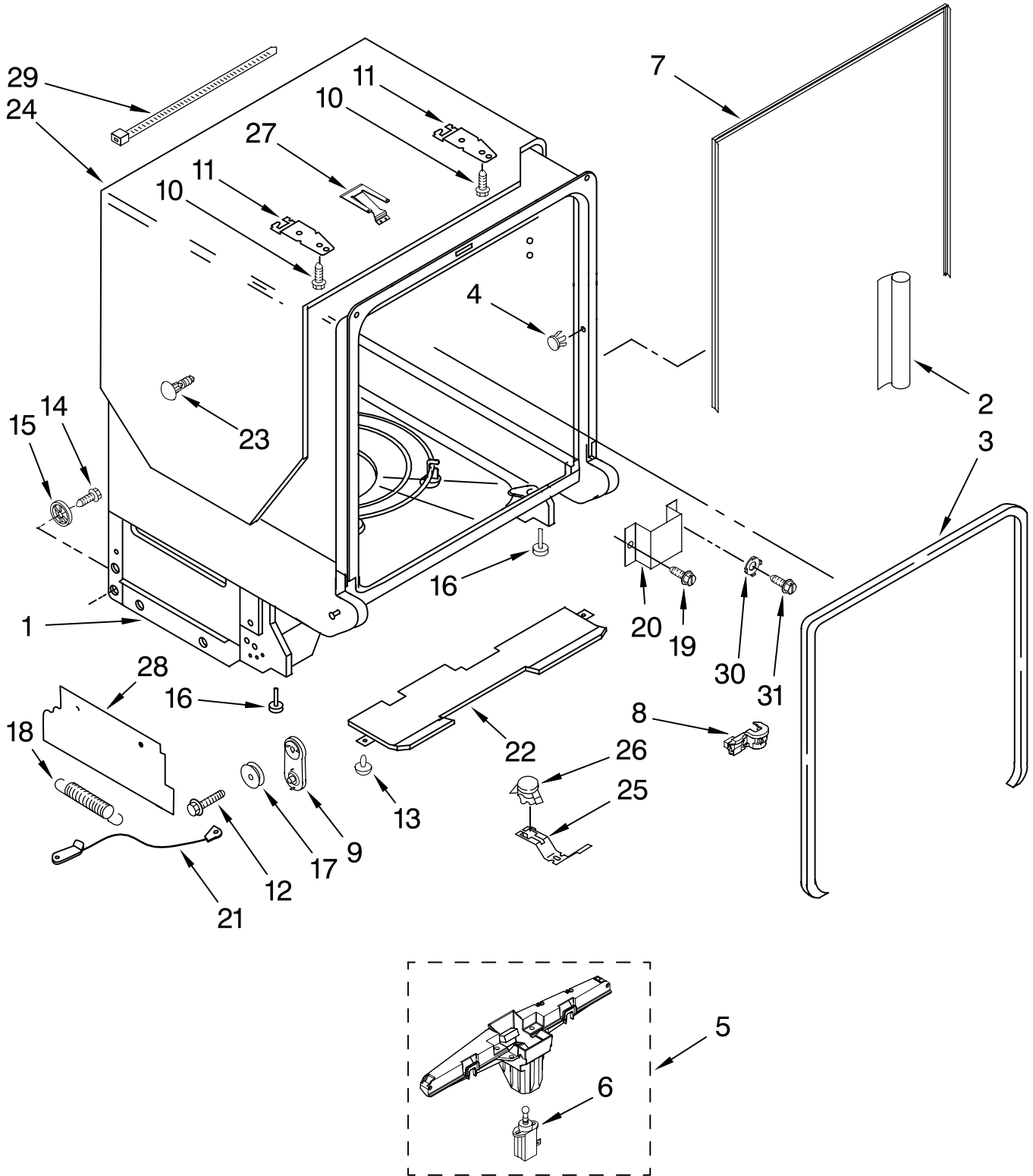

FOR ORDERING INFORMATION REFER TO PARTS PRICE LIST

TUB AND FRAME PARTS

For Models: KUDT03FTPA2
(Panel Ready)

Illus. No.	Part No.	DESCRIPTION
1	W10084284	Tub Assembly
2	8574123	Barrier, Moisture Undercounter
3	W10112096	Door Seal
4	W10082838	Plug Tub
5	8572661	Actuator Assembly
6	W10082767	Motor, Wax
7	8269110	Seal, Cabinet
8	8573061	Strain Relief
9	8270021	Mount, Door Balance
10	3367670	Screw
11	8269145	Bracket, Undercounter
12	3400074	Screw
13	3400924	Retainer, Push-in
14	3370389	Screw
15	8268977	Wheel Leg
16	8524584	Leveler, Leg
17	8524474	Wheel, door Balance
18	8270020	Spring, Door Balance
19	3400892	Screw
20	8268991	Cover, Terminal Box
21	8535568	Link, Door Balance
22	8268582	Insulator, Sound
23	304666	Retainer, Push
24	8573239	Shield, Sound Tub
25	9742648	Bracket, Thermostat
26	661566	Thermostat
27	W10077370	Strike, Latch
28	8537001	Shield, Side
29	8539404	Strap
30	3378128	Washer, Pronged
31	3400014	Screw

FOR ORDERING INFORMATION REFER TO PARTS PRICE LIST

PUMP AND MOTOR PARTS

For Models: KUDT03FPA2
(Panel Ready)

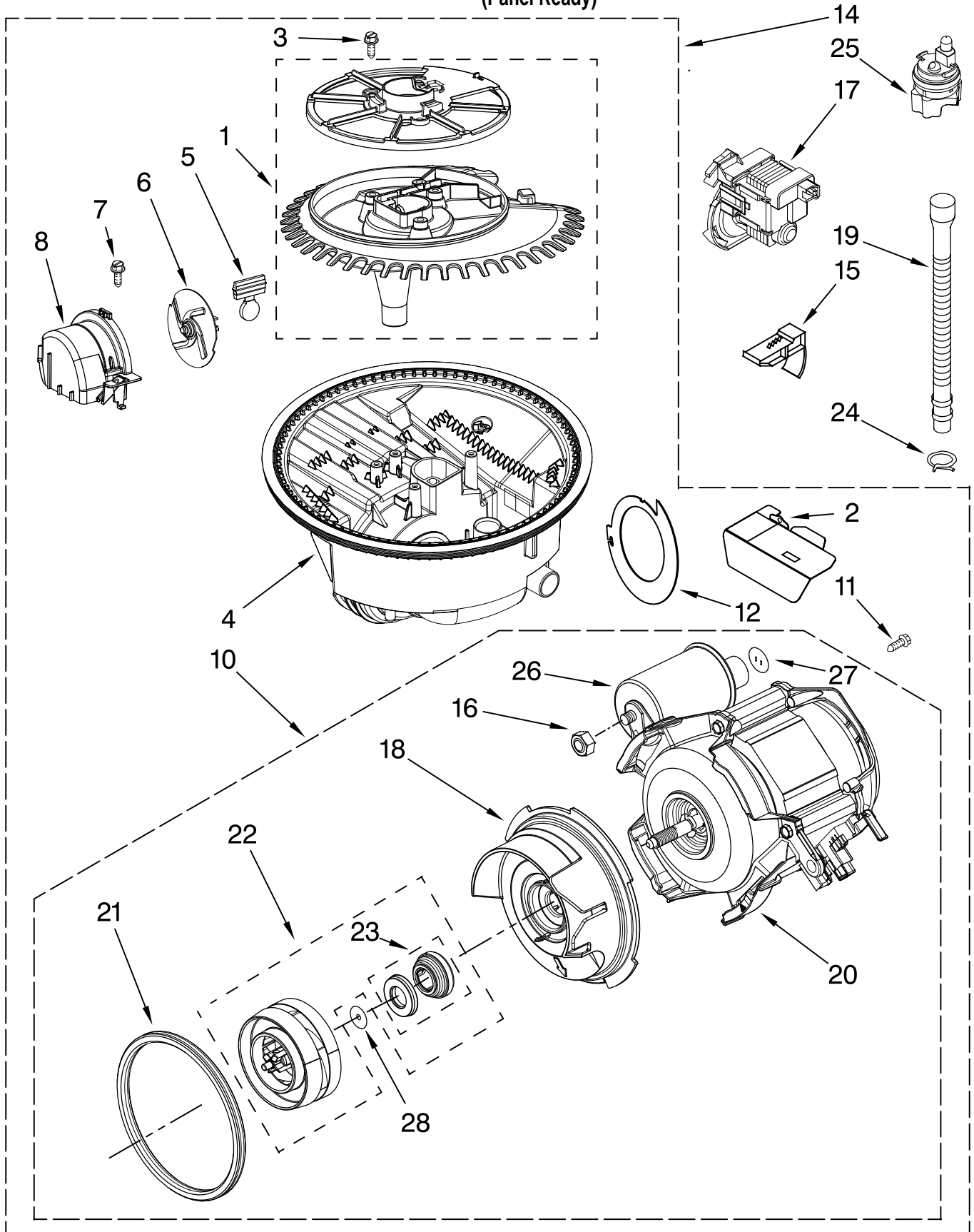

FOR ORDERING INFORMATION REFER TO PARTS PRICE LIST

PUMP AND MOTOR PARTS

For Models: KUDT03FPA2
(Panel Ready)

<u>Illus. No.</u>	<u>Part No.</u>	<u>DESCRIPTION</u>
1	8534952	Accumulator Assy
2	8283527	Shield, Motor
3	3400069	Screw
4	8572618	Sump With Seal
5	8268375	Check Valve, Sump
6	W10083957	Chopper Assembly
7	9741232	Screw
8	8531857	Protector, Inlet
10	8535760	Motor Assembly
11	3400217	Screw
12	8268391	Screen, Separation
14	W10084107	Sump & Motor Assembly (Includes Item 15)
15	8269524	Tab, Sump
16	8533949	Nut
17	661662	Pump, Drain
18	8531019	Volute, Back (Also Order Items 21 & 28)
19	8269144	Hose, Drain
20	8535759	Motor
21	8268397	Seal, Volute
22	8531017	Impeller Kit (Also Order Item 28)
23	8268403	Face Seal Assembly (Also Order Item 28)
24	356138	Clamp, Hose
25	W10082647	Optical Water Indicator
26	8535474	Capacitor
27	8534946	Shield, Capacitor
28	8531018	Washer

FOR ORDERING INFORMATION REFER TO PARTS PRICE LIST

UPPER RACK AND TRACK PARTS

For Models: KUDT03FTP A2
(Panel Ready)

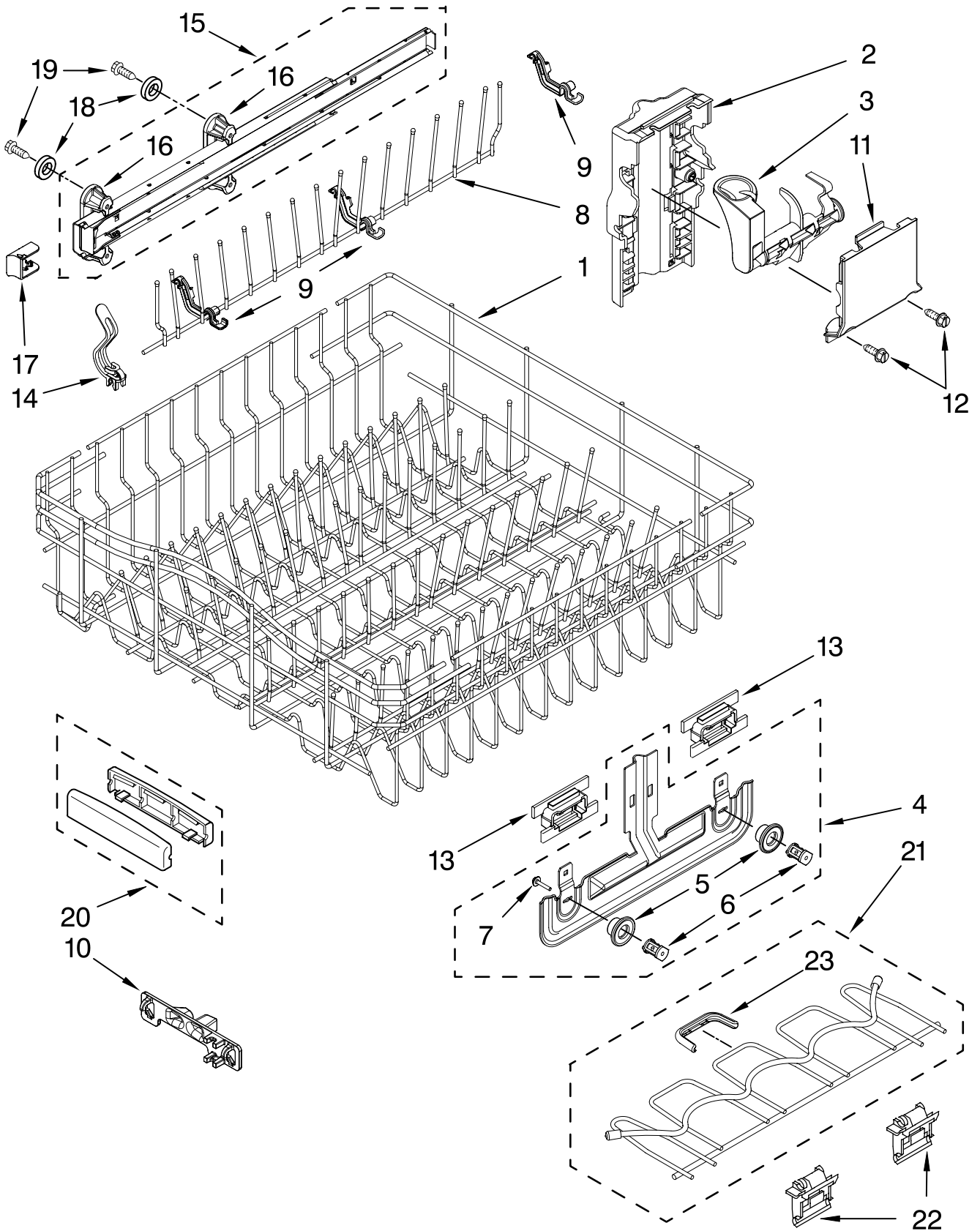

FOR ORDERING INFORMATION REFER TO PARTS PRICE LIST

UPPER RACK AND TRACK PARTS

For Models: KUDT03FTPA2
(Panel Ready)

Illus. No.	Part No.	DESCRIPTION
1	W10078137	Dishrack, Upper
2	W10082839	Housing, Adjuster
3		Actuator, Adjuster
	W10077838	Right Hand
	W10077839	Left Hand
4	8268653	Adjuster Assembly
5	8270138	Wheel
6	8268703	Axel, Adjuster
7	8281156	Screw
8	9744566	Tine Row
9	W10082853	Clip, Pivot
10	8539102	Positioner, Dual
11	W10082840	Cover, Adjuster
12	9741232	Retainer
13	W10082834	Positioner, Arm
14	W10077844	Clip, No-Flip
15		Track, Assembly
	W10078218	Right Hand
	W10078217	Left Hand
		(Also Order Item 18)
16	W10077876	Mount, Track
		(Also Order Item 18)
17	W10077854	Stop, Track
18	9743002	Gasket, Bracket Mounting
19	3400072	Screw
20	8539110	Handle, Dishrack
21	W10077957	Cupshelf
22	8562026	Clip, Cupshelf
23	W10077843	Indicator, Cupshelf

UPPER WASH AND RINSE PARTS

For Models: KUDT03FTP A2
(Panel Ready)

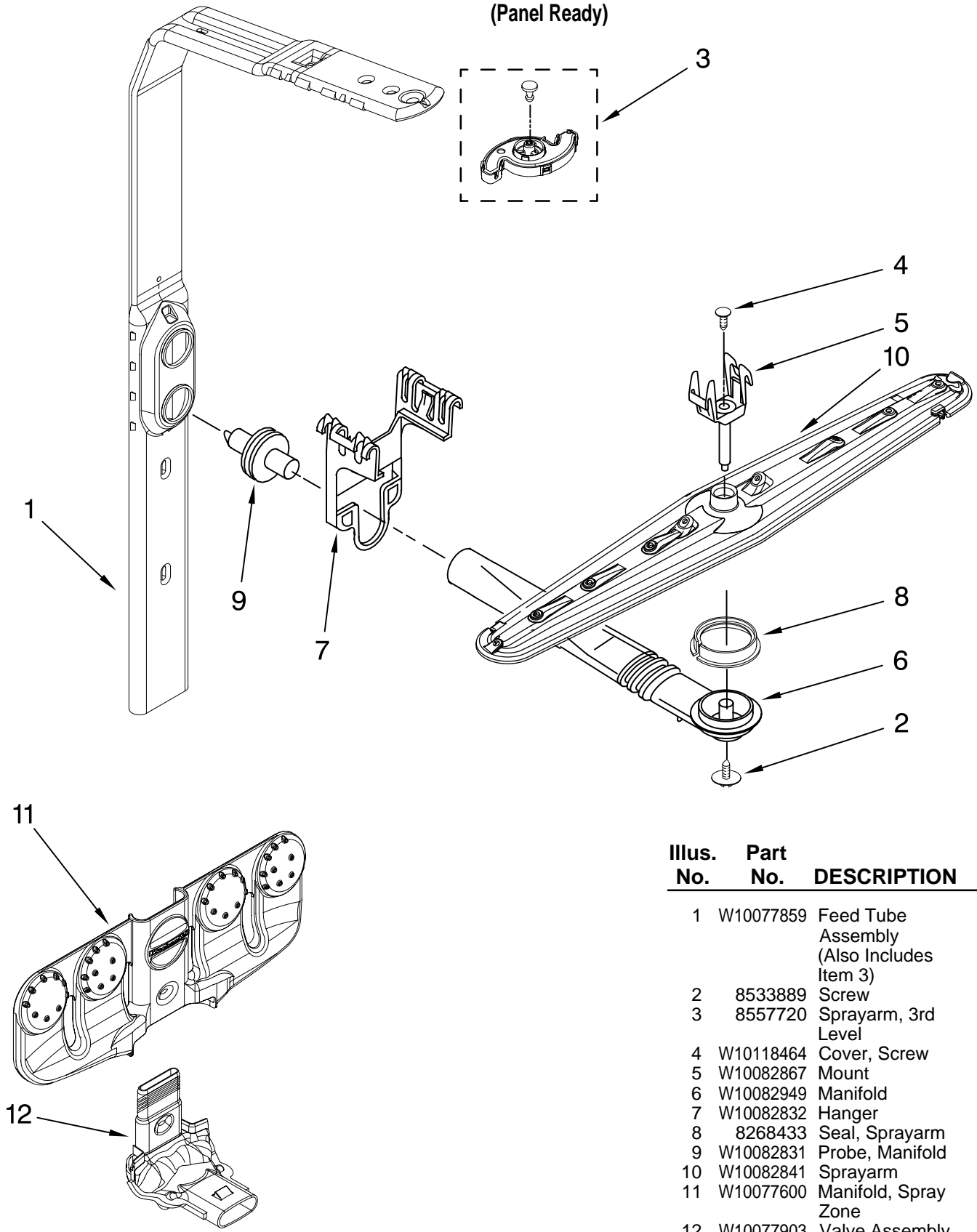

Illus. No.	Part No.	DESCRIPTION
1	W10077859	Feed Tube Assembly (Also Includes Item 3)
2	8533889	Screw
3	8557720	Sprayarm, 3rd Level
4	W10118464	Cover, Screw
5	W10082867	Mount
6	W10082949	Manifold
7	W10082832	Hanger
8	8268433	Seal, Sprayarm
9	W10082831	Probe, Manifold
10	W10082841	Sprayarm
11	W10077600	Manifold, Spray Zone
12	W10077903	Valve Assembly, Manifold

FOR ORDERING INFORMATION REFER TO PARTS PRICE LIST

LOWER RACK PARTS

For Models: KUDT03FTP A2
(Panel Ready)

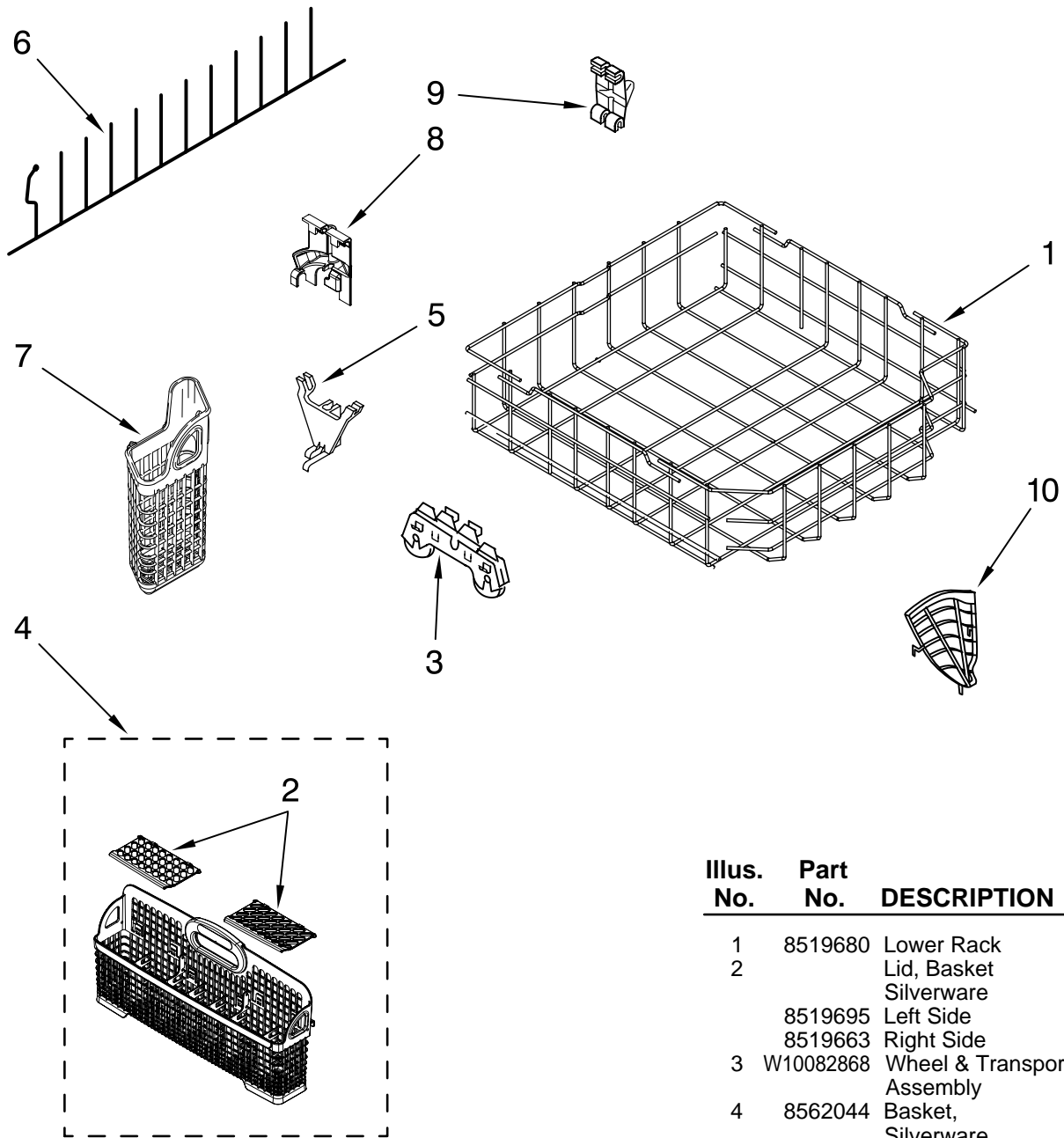

Illus. No.	Part No.	DESCRIPTION
1	8519680	Lower Rack
2		Lid, Basket Silverware
	8519695	Left Side
	8519663	Right Side
3	W10082868	Wheel & Transport Assembly
4	8562044	Basket, Silverware
5	W10078227	Pivot, Tine Row
6	8519682	Tine, Row
7	8519702	Basket, Utensil
8	W10078215	Retainer, Tine Row (Combo)
9	8531314	Retainer, Tine Row
10	8562069	Holder, Knife

FOR ORDERING INFORMATION REFER TO PARTS PRICE LIST

THIRD LEVEL RACK AND TRACK PARTS

For Models: KUDT03FTP A2
(Panel Ready)

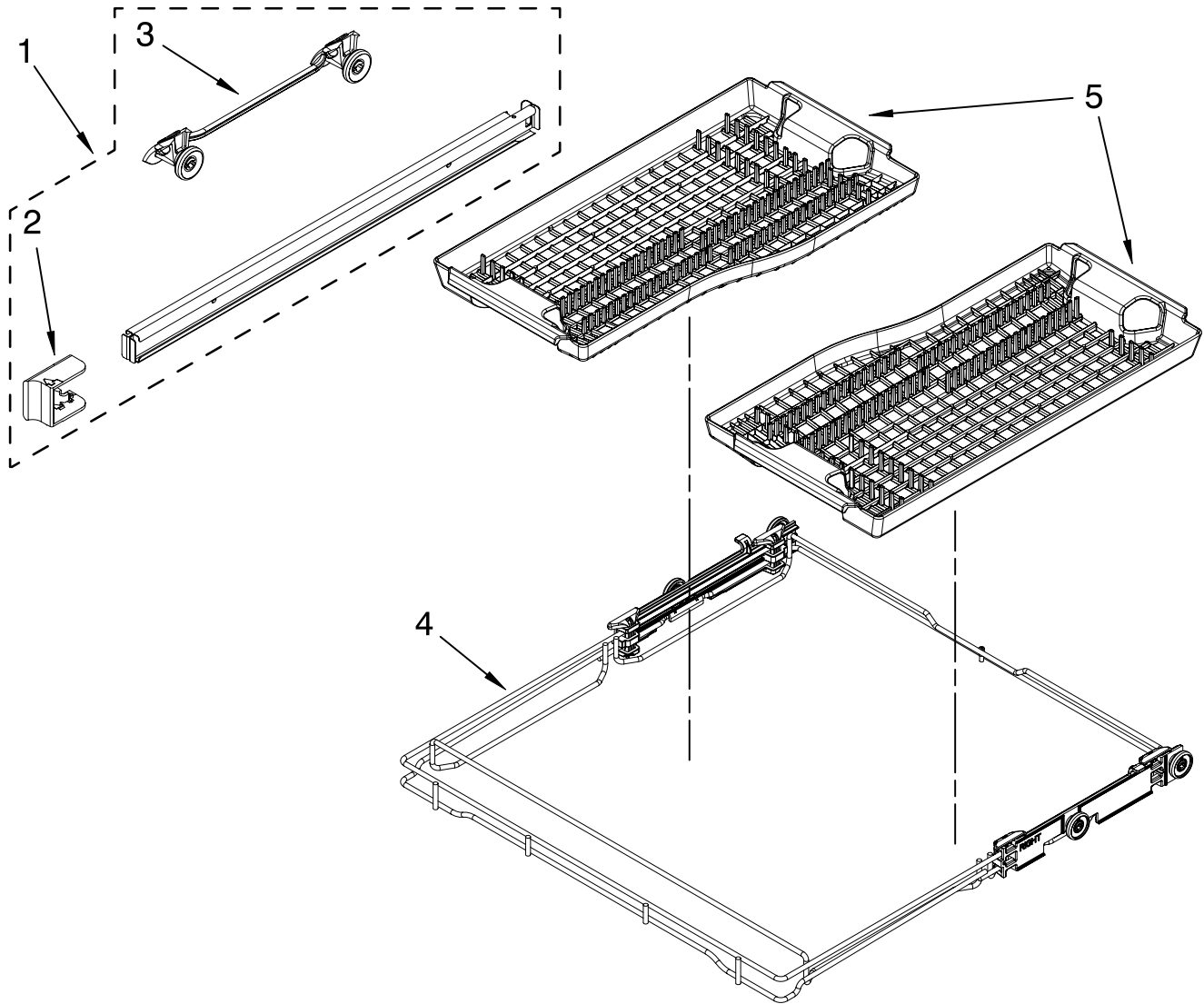

Illus. No.	Part No.	DESCRIPTION
1	W10077855	Track Right
	W10077856	Track Left
2	W10077854	Stop, Track
3	8564899	Mount, Track
4	W10078012	Rack Assembly (Third Level)
5	8564901	Basket-TLR

FOR ORDERING INFORMATION REFER TO PARTS PRICE LIST

OPTIONAL PARTS (NOT INCLUDED)

For Models: KUDT03FPA2
(Panel Ready)

Illus. No.	Part No.	DESCRIPTION	Illus. No.	Part No.	DESCRIPTION	Illus. No.	Part No.	DESCRIPTION
ACCESSORIES			PAINT, TOUCH-UP (1/2oz.)			POWER CORD KIT		
		Side Panel Kits			72017 White			4317824 Power Cord Kit
		8171656 White			72032 Black			(Includes Power
		8171657 Black			4392899 Biscuit			Cord & Misc.
		8171658 Biscuit			4396603 Meteorite			Hardware)
		8171659 Stainless Steel			PAINT, PRESSURIZED SPRAY			ANTI-TIP KIT
		Custom Panel & Trim Kit			(12 oz.)			
		8212489 Black			350930 White			8171477 Floor Mount Kit
		Towel Bar Handle Kit			285006 Superior Black			DISHRACK REPAIR
		8573938 Stainless Steel			4392901 Biscuit			
		Drain Hose			PAINT, BULK (1 qt.)			4396838 White
		3385556 12 Ft.			799344 White (Uncut)			4396840 Grey
		Vinyl Touch-Up (4oz.)			4392900 Biscuit			4396854 Silver Atlantis
		676453 White						
		676455 Grey						
		4396853 Silver Atlantis						
		Moisture Barrier Kit						
		4396277 Kit						

FOR ORDERING INFORMATION REFER TO PARTS PRICE LIST