

AUTO-LOGIC

Panasonic

Operating Instructions

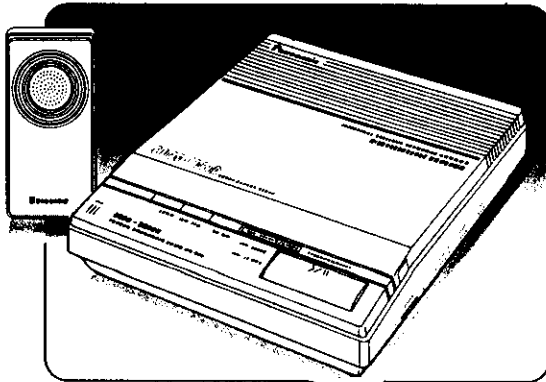

Please read before use.

AUTOMATIC TELEPHONE
ANSWERING SYSTEM
Model No. **KX-T1418**

EASA-PHONE
Thank you for purchasing
the Panasonic Telephone
Answering System.

La tarjeta de referencia rápida en español
puede encontrarse en las páginas 9~10.
(Spanish quick reference card can be found
on pages 9~10.)

Connection

1 Connect as shown.

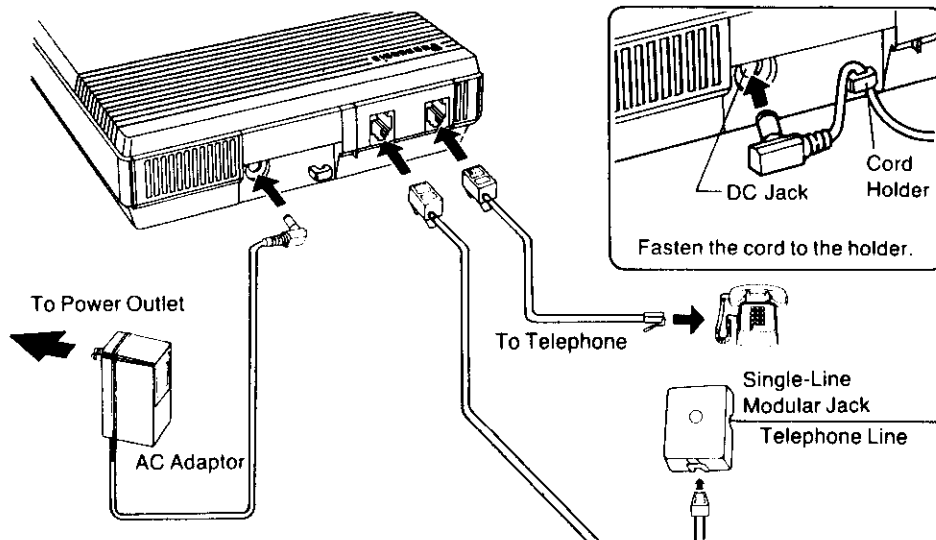

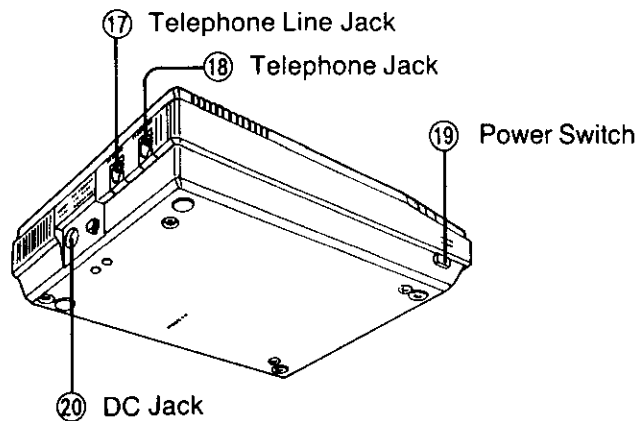
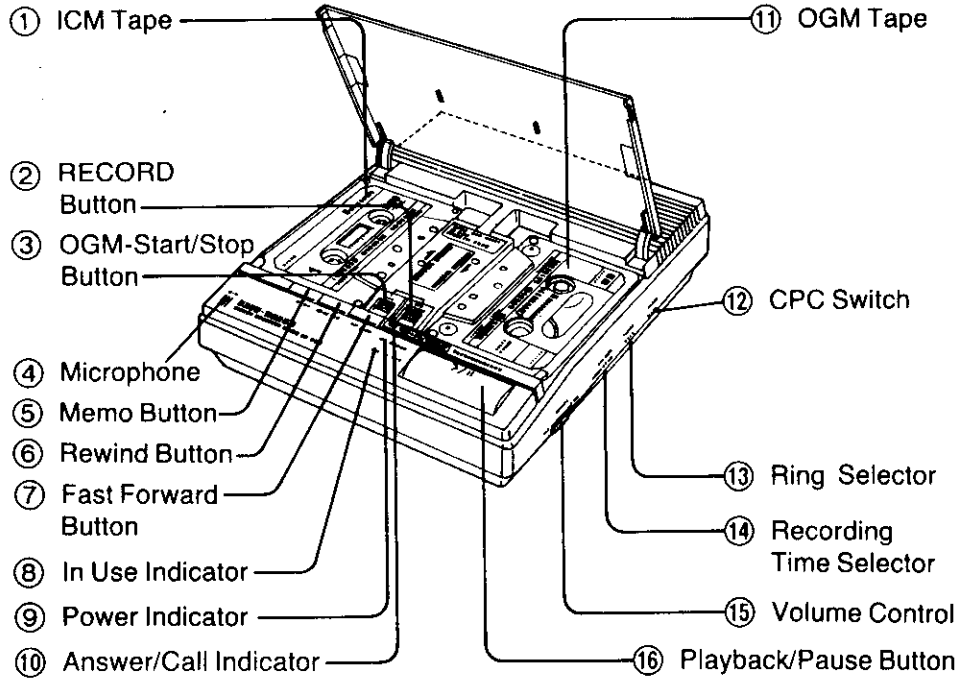

Location of Controls

Automatic Telephone Answering System



Preparation

- 1 Push the power switch on.
 - Power Indicator will light.
- 2 Insert  and  , and then reset the OGM tape by pushing the OGM START/STOP button.
 - Wait until In Use Indicator goes out.

- 3 Select each selector.

⑫ CPC switch

- Set to "A".
Usually set to "A".
(No call waiting service line)
Set to "B" when your line has call waiting service.
Or if some incoming messages are incomplete.

⑭ Recording Time Selector

- 1 MINUTE:**
 - The unit will record up to 1 minute.
- VOX:**
 - The unit will record for as long as the caller speaks.

⑬ Ring Selector

- 2:**
 - The unit will answer the telephone on the second ring.
- 4:**
 - The unit will answer the telephone on the fourth ring.
- AUTO:**
 - The unit will answer on the second ring if any incoming messages have been recorded.
 - The unit will answer on the fourth ring when no incoming messages have been recorded.

Battery Installation for Remote Controller

- 1 Open the Battery Compartment cover as shown below.

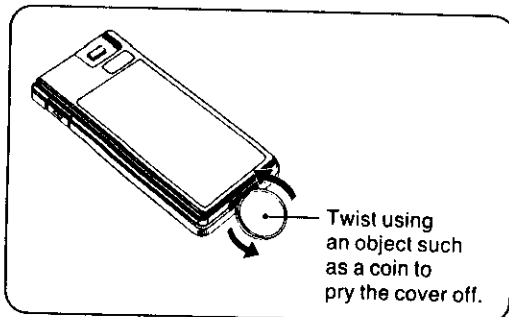

- 2 Insert "AAA" size batteries (UM-4 or equivalent) observing correct polarity (plus and minus).
- 3 Replace the Battery Compartment cover.



Notes:

- If the Pickup Remote Controller is not to be used for a long time, remove all the batteries to prevent possible damage.
- The battery life is about one year for average usage.
- When the sound from the Pickup Remote Controller becomes weak, replace all the

How to Record Outgoing Message (OGM)

The purpose of the Outgoing Message is to inform the calling party that you cannot answer, but want to record the caller's message.

Recording

- 1  While keeping it pushed, push the  until a beep sound is heard.

- One beep tone will be heard.
- Please take care so as not to push the FF button.

- 2 Speak clearly and loudly to .

- Speak up to 30 seconds from about 8 inches away from MIC.
- While recording, do not pause for over 2 seconds.

- 3 When you finished,  .

- Wait until the In Use indicator goes out.
- A series of short beeps will be heard to advance the tape followed by a long beep signaling that the unit is at the beginning of the tape.
- If you make a mistake, repeat from the step 1.

Confirming

- 4  .

- Adjust the volume control to confirm.
- Wait until the In Use indicator goes out.

Re-recording

If you want to record again, repeat from step 1.

Note:

- If you pause for over 2 seconds while recording, a beep will sound 6 times. So wait until the In Use indicator goes out and start with the step 1 over.
- The unit will automatically change to the answer set mode after 7 seconds from the In Use indicator goes out.

Sample of Outgoing Message

- Set Recording Time Selector to "1 MINUTE".

Hello, this is (the Panasonic Company). We cannot answer your call at this time. If you leave your name and phone number, we will return your call as soon as possible. Speak clearly after you hear the beep. You have 1 minute to leave your message.

If the beep sounds 6 times, your message will not be recorded. Should this happen please call back tomorrow.

Note:

When the ICM tape is full, the unit cannot record any more messages. This is indicated to the caller by 6 beep tones. If you wish to inform the caller of this possibility, add the sentences (printed in bold-face above) to your OGM recording.

- Set Recording Time Selector to "VOX".

Hello, this is (the Panasonic Company). We cannot answer your call at this time. If you leave your name, phone number and the purpose of your call, we will return your call as soon as possible. Please speak clearly after you hear the beep.

Setting Prior to Leaving

The unit will automatically set to the Answer mode by simply pushing the Power Switch. When the telephone rings, the unit will play back the OGM, then it will record the Caller's messages on the ICM tape.

Preparation

After reviewing the Outgoing or Incoming message the unit will automatically reset itself to the Answer set position and will be ready to answer the next call.

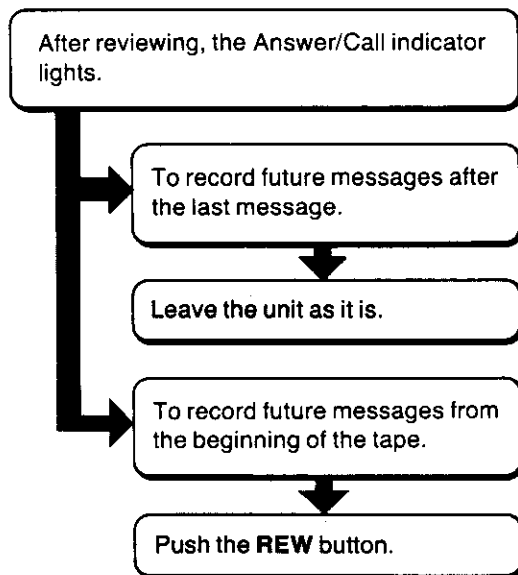

- When you use a new ICM tape or record future messages from the beginning of the tape, push the REW button.
- Confirm that the Answer/Call indicator light is on.
- If you do not want to set the unit to the Answer mode, push the Power Switch to off.

Listening to Messages

When an incoming message has been recorded, the Answer/Call indicator will flash in group. Each group indicates the number of incoming messages up to 15 (i.e. Three flashes followed by a pause means that 3 messages were received).

In the case of a power interruption, the Answer/Call indicator will flash slowly after the power is restored.

To Listen to Messages



Auto-Logic (One Touch Operation)

ICM tape will automatically rewind and begin to play back. At the end of all the messages 3 beeps will be heard.

7 seconds after the 3 beeps are heard the unit will reset back to the Answer mode.

- Future incoming messages will be recorded after the last message. To record from the beginning of the tape, push the REW button.

To Stop the Tape Temporarily



- The In Use Indicator will flash.
- To release, push it again.
- While in the pause mode, the unit will not change to the Answer mode.

To Rewind (Fast Forward) the Tape



- To release, push the Playback/Pause Button again.

Other Features

Monitoring the Incoming Calls



While an incoming message is being recorded.

1 Adjust the volume control.

- If the tape does not stop after the caller hangs up, use the unit with setting the recording time selector to "1 MINUTE".

How to Speak to the Caller Directly

1 Lower the Volume level using the Volume Control to prevent a howling noise and lift the .

2  **PLAYBACK/PAUSE**  until the ICM tape stops moving, and talk.

- The unit will automatically be ready to answer and record the next call.

3 When finished, hang up the .

Message Memo

To record confidential message, any time at home, on the ICM tape to be heard by someone using the unit.

1  **MEMO** until a beep sound is heard.

2 Speak into the .



3 When finished,  **MEMO**.

- The unit will be ready to answer the next call.

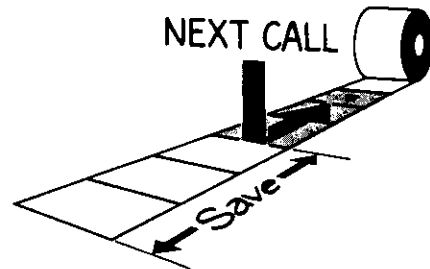
Save the Recorded Messages





1 Play back the tape until the message you want to save.

2  **PLAYBACK/PAUSE**  while keeping it pushed, push the rewind button.

- The unit will go into the Answer mode and future incoming messages will be recorded after the messages you have saved.

Erasing the Recorded Message

To erase the incoming messages:

 **REC** while keeping it pushed, push the  or  until a beep is heard.

- The messages are erased while rewinding or fast forwarding.
- The cassette can be erased at high speed even if the record-prevention (knock-out) tabs have been removed.

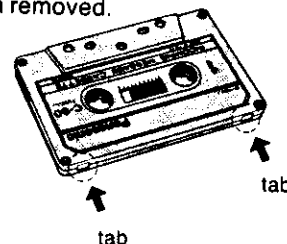

Cassette Tapes

- For optimum sound quality and performance, we recommend that you **replace the OGM and the ICM cassette tapes every six months and re-record the outgoing message every three months** assuming that the unit answers about ten calls a day.
- Never place a cassette tape near a magnetic source, such as a magnet or a TV set, because this will affect tape quality.

Endless Cassette Tape (KX-C030) for Outgoing Message

- A sensing foil (silver) is attached to the endless tape. If the sensing foil does not contact the sensing switch, the endless tape cannot stop automatically. Replace it with a new Panasonic endless cassette tape. (KX-C030).
- Observe carefully that the tape and capstan are located as shown below, and insert the endless tape into the machine.

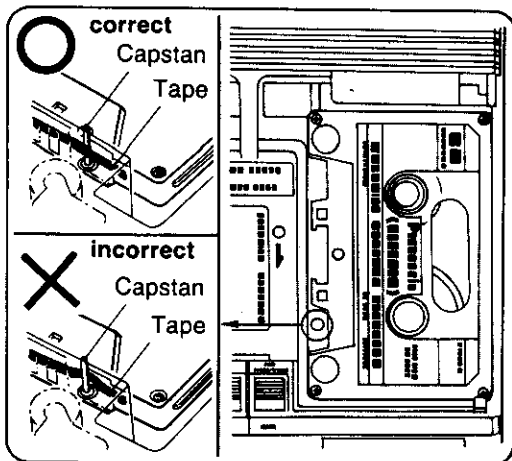

The following endless cassette tapes can also be used with this unit:

- KX-C010 • KX-C020

Disconnect the telephone cord from the unit before Maintenance.

Cassette Tape (C-60) for Incoming Messages

- Should the Incoming Message cassette tape break or become worn, replace it with a high quality "NORMAL" tape. Use Panasonic (C-30, C-60, C-90), or other high quality tape. Metal or chrome tape cannot be used.
- Slack in the tape can be tightened by rotating the tape reel with a pencil.
- Do not use C-120 tape to prevent the tape from sticking.

Maintenance

Because the head and capstan assemblies are in contact with the tape, dirt and residue from the tape can easily adhere to these parts, causing distortion. These parts should be cleaned periodically in the manner described below:

- Disconnect the telephone cord from the unit before cleaning.
- **Clean the head surfaces, sensing switch, pressure rollers and capstans with a cotton swab.** If these surfaces are extremely dirty, dampen the cotton swab with alcohol.

Notes:

- Do not bring magnetic or metal objects, such as a screwdriver, near the head assemblies, as such objects could magnetize the heads.
- Do not oil any part of the unit.

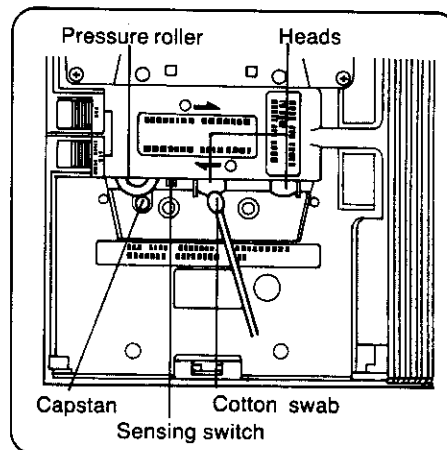

Pickup Remote Control

The Pickup Remote Controller produces a chirping sound in operation, and the answering machine responds to the Controller with a beep.

Push the buttons on the Controller continuously, until the beep is heard through the telephone line from the answering machine.

To Set the Answer mode

If you forgot to set the Answer mode:

■ To set

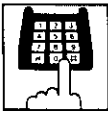

DIAL THE PHONE NO.
TO WHICH THE UNIT
IS CONNECTED



WAIT FOR
15 RINGS



- The unit will play back the outgoing message and then you may hang up the



Toll Saver

Set the Ring Selector to "Auto";
If you call from a remote location and the unit does not pick up on the third ring, hang up. This means no calls have been recorded and you will not be required to retrieve and pay toll charges.

- **Pick-up on the second ring:** At least one message has been recorded.
- **If does not pick-up on the third ring:** No messages have been recorded. So hang up.
- After you have played back all the messages from remote phone;
 - **Pick-up on the second ring in the next call:** At least one new message has been recorded.
 - If no pick-up occurs on the third ring, no messages have been recorded.

Playback Messages

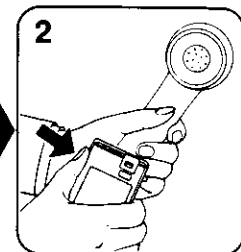
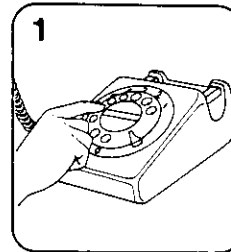

- 1 Dial the telephone number** to which the answering machine is connected.
- 2 While the Outgoing Message is playing,** place the Controller's speaker against the telephone mouthpiece and push the **Play Back Button**.
 - One beep will sound then another beeps will sound to tell you the number of recorded messages, up to 8 times.
 - The unit will rewind with voice and play back all the recorded incoming messages automatically, **even at tape end**.
 - 3 beeps will be heard after the last message.
- 3 Hang up.**
 - Future incoming messages will be recorded after the most recently recorded message.

Remote Reset

- To record the future incoming messages from the beginning of the tape.
 - After the recorded messages are played back or while they are playing;
 - 1 Push the Playback/Reset Button** again.
 - 2 Hang up.**

Memory Playback

When you have already heard the messages from a remote phone, you can skip them and listen only to the newly recorded messages.

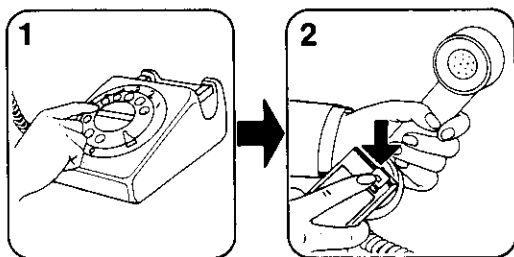

1 Dial the telephone number to which the answering machine is connected.

2 While the Outgoing Message is playing, place the Controller's speaker against the telephone mouthpiece and push the **Memory Playback Button**.

- One beep will sound then another beeps will sound to tell you the number of newly recorded messages, up to 8 times.
- The unit will play back the new messages.

Remote Reset

■ To record the future incoming messages from the first message that you heard by the Memory playback;

1 Push the Memory Playback/Reset Button again.

2 Hang up.

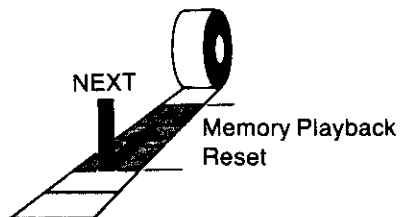

■ To record the future incoming messages from the beginning of the tape after you used Memory playback;

1 Push the Playback Button.

- The unit will rewind to the beginning of the tape and then playback the incoming messages.

2 Push the Playback Button again while playing back.

- Future messages will be recorded from the beginning of the tape.

3 Hang up.

Recording a Marker Message

After hearing all messages, you can leave your index message on the tape.

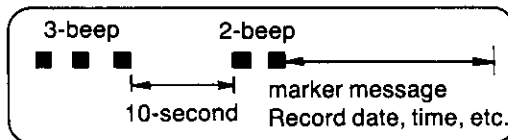

3 beeps will be heard after all the recorded messages have been played back.

1 Start to talk right after the last 2 beeps.

2 When finished, hang up.

NOTE

If there is no response from the answering machine to your remote controller's command, the telephone might be equipped with a carbon microphone. For the improvement of the performance, please shake the handset to loosen carbon particles.

