

Owner's Manual

Dishwasher

ZBD1850

ZBD1870



Introduction

Your new Monogram dishwasher makes an eloquent statement of style, convenience and kitchen planning flexibility. Whether you chose it for its purity of design, practical features or assiduous attention to detail—or for all of these reasons—you'll find that your Monogram dishwasher's superior blend of form and function will delight you for years to come.

The information on the following pages will help you operate and maintain your dishwasher properly. If you have any other questions, visit our Website at: monogram.com

Contents

| | | | |
|--|-----------|---------------------------|-------|
| Appliance Registration | 3, 23, 24 | Problem Solver | 15-17 |
| Care and Cleaning | 12-14 | Safety Instructions | 4, 5 |
| Consumer Services | 3, 19 | Warranty | 18 |
| Model and Serial Number Location | 3 | | |
| Operating Instructions | 6-11 | | |
| Control Panel and Operation | 6, 7 | | |
| Water Temperature | 8 | | |
| Rinse Agent | 8 | | |
| Detergents | 9 | | |
| Dishwasher Racks | 10, 11 | | |

Before using your dishwasher

Read this manual carefully. It is intended to help you operate and maintain your new dishwasher properly.
Keep it handy for answers to your questions.

If you don't understand something or need more help, there is a list of toll-free consumer service numbers included on the Consumer Services page in the back section of this manual.

OR

Visit our Website at: monogram.com

Write down the model & serial numbers

You can locate your model and serial numbers on the tub wall just inside the door.

Before sending in the card, please write these numbers here:

Model Number

Serial Number

Use these numbers in any correspondence or service calls concerning your dishwasher.

If you received a damaged dishwasher

Immediately contact the dealer (or builder) that sold you the dishwasher.

Save time & money

Before you request service, check the Problem Solver in the back of this manual.

It lists causes of minor operating problems that you can correct yourself.

If you need service

To obtain service, see the Consumer Services page in the back of this manual.

We're proud of our service and want you to be pleased. If for some reason you are not happy with the service you receive, here are steps to follow for further help.

FIRST, contact the people who serviced your appliance. Explain why you are not pleased. In most cases, this will solve the problem.

NEXT, if you are still not pleased, contact us on our website, write all the details—including your phone number—or write to:

Manager, Customer Relations
GE Appliances
Appliance Park
Louisville, KY 40225

IMPORTANT SAFETY INSTRUCTIONS

READ ALL INSTRUCTIONS BEFORE USE

SAVE THESE INSTRUCTIONS

▲ WARNING!

For your safety, the information in this manual must be followed to minimize the risk of fire or explosion, electric shock, and to prevent property damage, personal injury, or death.

▲ WARNING! WATER HEATER SAFETY

*Under certain conditions, hydrogen gas may be produced in a water heater that has not been used for two weeks or more. **HYDROGEN GAS IS EXPLOSIVE.***

If the hot water has not been used for two weeks or more, prevent the possibility of damage or injury by turning on all hot water faucets and allow them to

run for several minutes. Do this before using any electrical appliance which is connected to the hot water system. This simple procedure will allow any built-up hydrogen gas to escape. Since the gas is flammable, do not smoke or use an open flame or appliance during this process.

▲ PROPER INSTALLATION AND MAINTENANCE

This dishwasher must be properly installed and located in accordance with the Installation Instructions before it is used. If you did not receive an Installation Instructions sheet with your dishwasher, you can receive one by visiting our website at monogram.com.

- Connect to a grounded metal, permanent wiring system; or run an equipment-grounding conductor with the circuit conductors and connect to the equipment-grounding terminal or lead of the appliance.
- Improper connection of the equipment-grounding conductor can result in a risk of electric shock. Check with a qualified electrician or service representative if you are in doubt whether the appliance is properly grounded.
- Dispose of discarded appliances and shipping or packing material properly.
- Do not attempt to repair or replace any part of your dishwasher unless it is specifically recommended in this manual. All other servicing should be referred to a qualified technician.
- To minimize the possibility of electric shock, disconnect this appliance from the power supply before attempting any maintenance.

NOTE: *Turning the dishwasher off does not disconnect the appliance from the power supply. We recommend having a qualified technician service your appliance.*

▲ CAUTION: To prevent minor injury or property damage

- Contents washed in Anti-bacterial mode, if available, may be hot to the touch. Use care before handling.

- Using a detergent that is not specifically designed for dishwashers will cause the dishwasher to fill with suds.

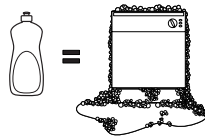

- If your dishwasher is connected to a wall switch, ensure that the switch is on prior to use.

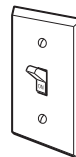

- On dishwashers with electronic controls, if you choose to turn the wall switch off between wash cycles, allow 5–10 seconds after turning the switch on before touching ON/OFF to allow the control to initialize.

- Non-Dishware Items: Do not wash items such as electronic air cleaner filters, furnace filters and paint brushes in your dishwasher. Damage to dishwasher and discoloration or staining of dishwasher may result.

- Close supervision is necessary if this appliance is used by or near children.

- Load light, plastic items so they will not become dislodged and drop to the bottom of the dishwasher—they might come into contact with the heating element and be damaged.

IMPORTANT SAFETY INSTRUCTIONS

▲ **WARNING! RISK OF CHILD ENTRAPMENT**

PROPER DISPOSAL OF THE DISHWASHER

Junked or abandoned dishwashers are dangerous...even if they will sit for "just a few days." If you are getting rid of your old dishwasher, please follow the instructions below to help prevent accidents.

Before You Throw Away Your Old Dishwasher:

- Take off the door of the washing compartment or remove the door latch keeper (as shown).

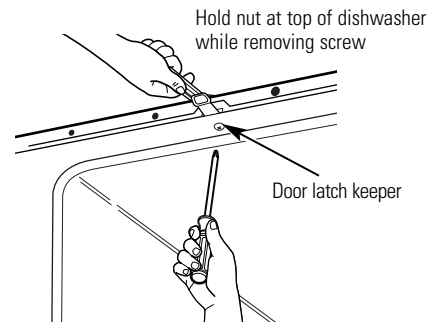

▲ **WARNING!** *When using your dishwasher, follow basic precautions, including the following:*

- Use this appliance only for its intended purpose as described in this Owner's Manual.
- Use only powder, tabs, liquid detergents or rinse agents recommended for use in a dishwasher and keep them out of the reach of children. **Cascade®**, **Cascade® Complete** and **Electrasol®** Automatic Dishwashing Detergents, and **Jet-Dry®** and **Cascade Crystal Clear®** rinse agents have been approved for use in all GE dishwashers.
- Locate sharp items so that they are not likely to damage the door seal.
- Load sharp knives with the handles up to reduce the risk of cut-type injuries.
- Do not wash plastic items unless marked dishwasher safe or the equivalent. For plastic items not so marked, check the manufacturer's recommendations.
- Do not touch the heating element during or immediately after use.
- Do not operate your dishwasher unless all enclosure panels are properly in place.
- Do not tamper with controls.
- Do not abuse, sit on or stand on the door or dish rack of the dishwasher.
- Do not allow children to play around dishwasher when opening or closing door due to the possibility of small fingers being pinched in door.
- Do not discard a dishwasher without first removing the door or the door latch keeper of the washing compartment.
- Do not store or use combustible materials, gasoline or other flammable vapors and liquids in the vicinity of this or any other appliance.
- Do not allow children to play with, on or inside this appliance or any discarded appliance.

**READ AND FOLLOW THIS SAFETY INFORMATION CAREFULLY.
SAVE THESE INSTRUCTIONS**

Control Panel

Dishwasher

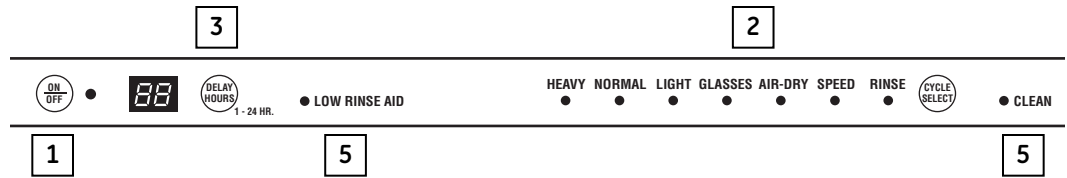

1 ON/OFF With door open, press ON/OFF button to turn the unit ON to begin operation and OFF at the end of a wash cycle. The ON/OFF light is displayed when the dishwasher is ON.

2 WASH CYCLE SELECTIONS Press CYCLE SELECT button to choose wash cycle. The light under the cycle name will display to indicate which cycle has been selected.

NOTE: All cycle times and water usage information contained in this section are approximate values. Actual results will depend on several factors including, but not limited to, inlet water temperature and household water pressure.

| | |
|----------------|--|
| HEAVY | 6.2 gallons, 125 minutes This cycle is meant for heavily soiled dishes or cookware with dried-on or baked-on soils. This cycle may not remove burned-on foods. Everyday dishes are safe to be used in this cycle. This cycle also includes heated dry. |
| NORMAL | 5.3 gallons, 100 minutes This cycle is meant for loads of everyday dishes, glasses and cookware with medium soils that have not been pre-rinsed. This cycle also includes heated dry. |
| LIGHT | 4.4 gallons, 85 minutes This cycle is meant for loads of everyday dishes, glasses and cookware with light soils that have been pre-rinsed. This cycle also includes heated dry. |
| GLASSES | 3.5 gallons, 65 minutes This cycle is meant for lightly soiled glassware. This cycle has less heating during the wash and rinse to protect your glassware. This cycle also has a lower temperature heated dry. |
| AIR-DRY | 3.5 gallons, 50 minutes This cycle is meant for loads of everyday dishes, glasses and cookware with light soils that have been pre-rinsed and should air dry naturally. This cycle does not include heated dry. |
| SPEED | 5.3 gallons, 80 minutes This cycle is meant for loads of everyday dishes, glasses and cookware with medium soils that have not been pre-rinsed. This cycle features reduced wash times to allow for faster cycle completion. This cycle also has a reduced time heated dry. |
| RINSE | 1 gallon, 10 minutes For rinsing partial loads that will be washed later. Do not use detergent with this cycle. This cycle does not include heated dry. |

Control Panel

Dishwasher

-
- 3 DELAY HOUR SELECTION** This option allows you to delay the start of a wash cycle for up to 24 hours. With the door open, turn the dishwasher ON by pressing the ON/OFF button; then press DELAY HOURS button to choose the number of hours you want to delay the start of the wash cycle. The hours will show in the display window.
- NOTE:** To cancel the DELAY HOURS option before the start of the cycle, repeatedly press the DELAY HOURS button until the display is blank or reads "00."
-
- 4 STARTING A CYCLE** After selecting the wash cycle (Step 2) and delay hours (Step 3), if desired, close the door of the dishwasher to start the cycle or begin the DELAY HOURS countdown. When the cycle starts, the drain begins and approximately 60 seconds later the water fill begins.
-
- 5 STATUS INDICATORS**
- LOW RINSE AID** The red light will display when the rinse aid dispenser needs to be refilled with liquid rinse aid. Use of **Jet-Dry®** or **Cascade Crystal Clear®** rinse agent removes spots and prevents new film buildup on your dishes, glassware, flatware, cookware and plastics. See page 6 for instructions on refilling the rinse aid dispenser.
-
- CLEAN** The green light will display and a beep will sound to alert you that the wash cycle is complete.
-

Check the Water Temperature

The entering water should be at least 120°F and not more than 150°F for effective cleaning and to prevent dish damage. Check the water temperature with a candy or meat thermometer.

Turn on the hot water faucet nearest the dishwasher, place the thermometer in a glass and let the water run continuously into the glass until the temperature stops rising.

Use a Rinse Agent

A rinse agent improves dry performance, reduces spots and prevents new film buildup on your dishes, glasses, flatware, cookware and plastic. **Jet-Dry®** and **Cascade Crystal Clear®** are recommended rinse agents for Monogram Dishwashers.

Filling the Dispenser

The rinse agent dispenser holds 3.5 oz. of rinse agent. Under normal conditions, this will last approximately one month. Try to keep it full, but do not overfill.

1. Make sure the dishwasher door is fully open.
2. Turn the dispenser cap to the left and lift it out.

3. Add rinse agent until the indicator window looks full.

4. Clean up any spilled rinse agent with a damp cloth.

5. Replace the dispenser cap.

Rinse Aid Setting

The amount of rinse agent released into the final wash can be adjusted. The factory setting is at the midpoint. If there are rings of calcium (hard water) spots on dishes, try a higher setting. If you observe foam in the final rinse, try a lower setting.

To adjust the setting, remove the dispenser knob; then turn the adjuster counterclockwise to increase the amount of rinse agent or clockwise to reduce the amount of rinse agent dispensed.

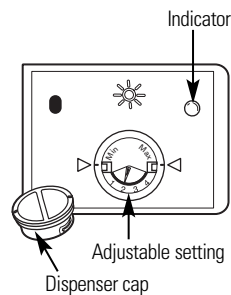

Dish Preparation Prior to Loading

- No prerinseing of normal food soil is required if using Heavy, Normal or Speed wash cycles.
- Scrape off hard soils, bones, toothpicks, skins and seeds.
- Remove large quantities of any remaining food.
- Remove leafy vegetables, meat, trimmings and excessive amounts of grease or oil.

Detergents

Use only detergent specifically made for use in dishwashers. **Cascade®** and **Electrasol®** Automatic Dishwashing Detergents have been approved for use in all Monogram Dishwashers. Keep your detergent fresh and dry. Don't put detergent into the dispenser until you're ready to wash dishes.

The amount of detergent to use depends on whether your water is *hard* or *soft*. With hard water, you need extra detergent. With soft water, you need less detergent.

Protect your dishes and dishwasher by contacting your water department and asking how hard your water is. Twelve or more grains is extremely hard water. A water softener is recommended. Without it, lime can build up in the water valve, which could stick while open and cause flooding. Too much detergent with soft water can cause a permanent cloudiness of glassware, called *etching*.

Use the information in the table below as a guideline to determine the amount of automatic dishwasher detergent to place in the dispenser.

When using automatic dishwasher detergent tablets, simply place one tablet in the dispenser and close the cover.

| Number of Grains | Detergent Cups to Fill |
|------------------|------------------------------|
| Less than 4 | 15 cup |
| 4 to 8 | 25 cup |
| 8 to 12 | 15 and 25 cups |
| Greater than 12 | 15, 25 cups and the open cup |

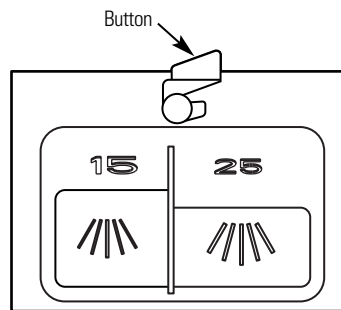

To open the wash cover, press the button and the cover will flip back.

Do not use hand dish detergent.

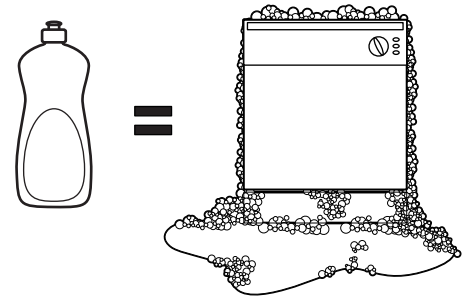

NOTE: Using a detergent that is not specifically designed for dishwashers will cause the dishwasher to fill with suds. During operation, these suds will spill out of the dishwasher vents, covering the kitchen floor and making the floor wet.

Because so many detergent containers look alike, store the dishwasher detergent in a separate space from all other cleaners. Show anyone who may use the dishwasher the correct detergent and where it is stored.

While there will be no lasting damage to the dishwasher, your dishes will not get clean using a dishwashing detergent that is not formulated to work with dishwashers.

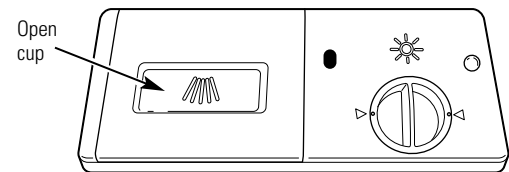

For heavily-soiled loads, use the Heavy cycle and add a little extra detergent.

Forget to add a dish?

A forgotten dish can be added any time before the main wash.

1. Unlatch the door to interrupt the cycle. Pull door handle to release the door.
2. Do not open the door until the water/spray action stops. Steam may rise out of the dishwasher.

3. Add forgotten dishes.

4. Close the door and push it in to relatch.

Loading the Racks

Dishwasher

For best dishwashing results, follow these loading guidelines. Features and appearance

of racks and silverware baskets may vary from your model.

Upper Rack

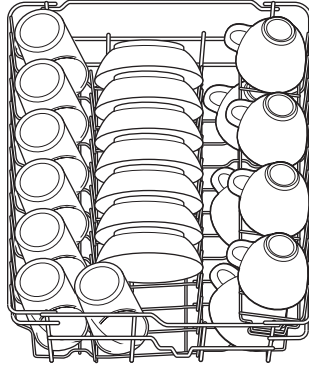

The upper rack is for glasses, cups and saucers. This is also a secure place for dishwasher-safe plastics. A cup shelf may be placed in the up or down position to add flexibility. The upper rack is good for all kinds of odd-shaped utensils. Saucepans, mixing bowls and other items should be placed face down.

Secure larger dishwasher-safe plastics over two tines when possible.

Make sure small plastic items are secure so they can't fall onto the heater.

Be sure that items do not protrude through the bottom of the rack and block rotation of the middle spray arm. This could result in poor wash performance for items in the upper rack.

Lower Rack

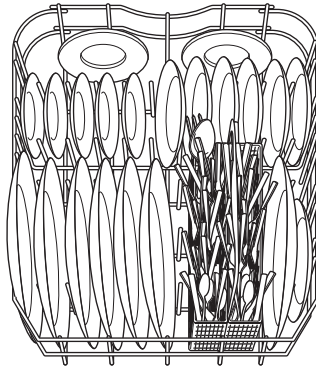

When loading the lower rack, do not load large platters or trays in the front left corner. They may prevent detergent from circulating during the wash cycle.

The lower rack is best used for plates, saucers and cookware. Large items should go along the sides. Load platters, pots and bowls along the sides, in corners or in the back. The soiled side of items should face the center of the rack.

Be careful not to let a portion of any item, such as a pot or dish handle, extend through the bottom rack. This could block the wash arm and cause poor washing results.

Wine Glass Holder

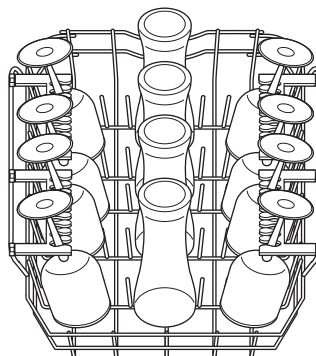

The Wine Glass Holder secures wine glasses for best washability. You may also remove the silverware basket to allow for all glasses loading of the lower rack.

Silverware Basket

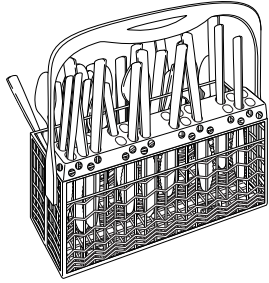
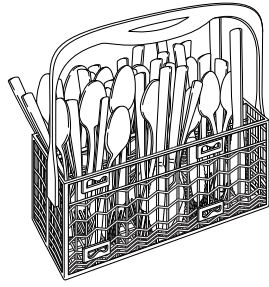

The silverware basket may be used without the topper for quick loading. With the topper, flatware is better positioned for the dishwasher to thoroughly wash and dry all pieces by preventing nesting.

Without the Topper

Put the flatware in the removable basket with fork and knife handles up to protect your hands. Place spoons in the basket with handles down. Mix knives, forks and spoons so they don't nest together. Distribute evenly. Small plastic items, such as measuring spoons and lids from small containers, should go in the bottom of the silverware basket with silverware on top.

With the Topper

Place small plastic items, such as measuring spoons and lids from small containers, in the bottom of the basket and snap the topper in place. Insert spoons and forks, handles first, through the holes in the topper. Place knives, blades first, through the holes in the topper.

Exterior

Cleaning the Door Panel

Before cleaning the front panel, make sure you know what type of panel you have. Refer to the last two letters of your model number. You can locate your model number on the left-hand tub wall just inside the door. If your model number ends with SS, then you have a Stainless Steel door panel.

Follow the instructions below for cleaning the door panel for your specific model.

Stainless Steel Door Panel (*model numbers ending in SS*)

The stainless steel panels can be cleaned with *Stainless Steel Magic* or a similar product using a clean, soft cloth. Do not use appliance wax, polish, bleach or products containing chlorine on Stainless Steel doors.

You can order *Stainless Steel Magic #WX10X15* through GE Parts by calling 800.626.2002.

Cleaning the Control Panel

To clean the control panel, use a lightly dampened cloth; then dry thoroughly. Do not use sharp objects, scouring pads or harsh cleaners on the control panel.

Spray Arms and Filters

The dishwasher will flush away all normal food soils. However, objects (fruit pits, bones, etc.) may collect in openings and should be removed occasionally to avoid clogging the drain system.

▲ CAUTION: Personal injury hazard. Before cleaning the interior, wait at least 20 minutes after a cycle for the heating element to cool down. Failure to do so could result in burn injuries.

Cleaning the Spray Arms

Because hard water chemicals will clog the spray arm jets and bearings, it is necessary to clean the spray arms regularly. To remove the spray arm, twist the retaining nut 90 degrees and pull the spray arm off the shaft.

Wash the arms in soapy, warm water and use a soft brush to clean the jets. Replace them after rinsing thoroughly.

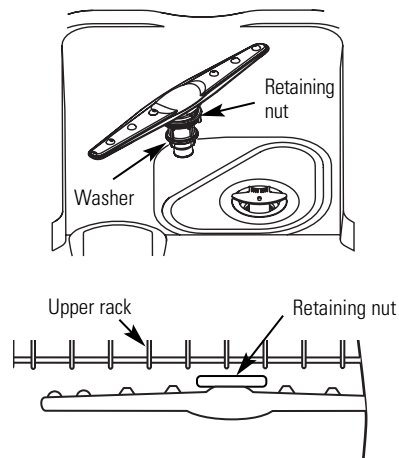

Cleaning the Filters

For best performance and results, the filter assembly must be cleaned regularly. The filter efficiently removes food particles from the wash water, allowing water to be recirculated during the cycle. For this reason, it is a good idea to remove the large food particles trapped in the filter frequently by rinsing the main filter and cup under running water. To remove the filter assembly, pull up on the cup handle. The entire filter assembly should be cleaned at least once a month. To clean the main filter and fine filter, use a cleaning brush. Then, reassemble the filter parts as shown in the illustration and reinsert the entire assembly in the dishwasher, positioning it in place and pressing downward. The dishwasher must never be used without the filters. Improper replacement of the filter may reduce the performance level of the appliance and may damage dishes and utensils.

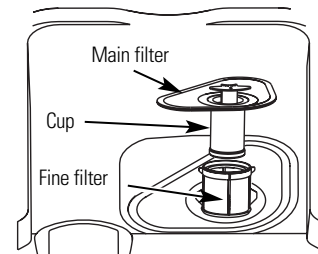

Protect Against Freezing

If your dishwasher is left in an unheated place during the winter, ask a service technician to:

1. Cut off electrical power to the dishwasher. Remove fuses or trip circuit breaker.
2. Turn off the water supply and disconnect the water inlet line from the water valve.
3. Drain water from the water inlet line and water valve. (Use a pan to catch the water.)
4. Reconnect the water inlet line to the water valve.

Does Your Dishwasher Have an Air Gap?

An air gap protects your dishwasher against water backing up into it if a drain clogs. The air gap is not a part of the dishwasher. It is not covered by your warranty. Not all plumbing codes require air gaps, so you may not have one.

The air gap is easy to clean.

1. Turn off the dishwasher and lift off the chrome cover.
2. Remove the plastic cap and clean with a toothpick.

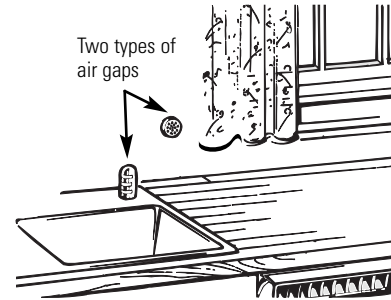

Check the air gap any time your dishwasher isn't draining well.

Stainless Steel Interior— Tub and Inner Door

The stainless steel used to make the dishwasher tub and inner door provides the highest reliability available in a Monogram dishwasher. If the dishwasher tub or inner door should be

scratched or dented during normal use, they will not rust or corrode. These surface blemishes will not affect their function or durability.

Questions?
Use this
problem
solver

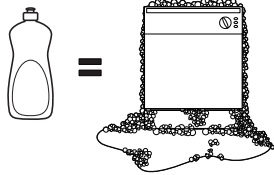
| PROBLEM | POSSIBLE CAUSE | WHAT TO DO |
|--|--|---|
| Noise | Some of the sounds you will hear are normal | <ul style="list-style-type: none"> • Detergent cup opening. • The motor starting during the drying period. • Water draining out of the tub immediately after you start the dishwasher. |
| | Utensils are not secure in the rack or something small has dropped into the rack | <ul style="list-style-type: none"> • Make sure everything is secured in dishwasher. |
| | Motor hums | <ul style="list-style-type: none"> • Dishwasher has not been used on a regular basis. If you do not use your dishwasher often, set it to fill and pump out once every week. This will help keep the seal moist. • Dishwasher control was not advanced properly to the start of the desired cycle. Advance the control to the start of the desired cycle. |
| Detergent left in dispenser cups | Dishes are blocking the detergent cups | <ul style="list-style-type: none"> • Reposition the dishes. |
| Water standing in the bottom of the tub | Drain is clogged | <ul style="list-style-type: none"> • If you have an air gap, clean it. • Check to see if your kitchen sink is draining well. If not, you may need a plumber. • If the dishwasher drains into a disposer, run disposer clear. |
| | This is normal | <ul style="list-style-type: none"> • A small amount of clean water around the outlet of the tub bottom at the back of the tub keeps the water seal lubricated. |
| Suds in the tub  | Correct detergent wasn't used | <ul style="list-style-type: none"> • Use only automatic dishwasher detergents to avoid sudsing. Cascade® and Electrasol® Dishwashing Detergents have been approved for use in all Monogram dishwashers. • To remove suds from the tub, open the dishwasher and let suds evaporate. Add 1 gallon of cold water to the tub. Close and latch the dishwasher. Pump out water by slowly turning the dial until a drain period is reached. Repeat if necessary. |
| | Rinse agent was spilled | <ul style="list-style-type: none"> • Always wipe up rinse agent spills immediately. |
| Stained dishwasher parts | Detergent with colorant was used | <ul style="list-style-type: none"> • Some detergents contain colorant (pigment or dyes) that will discolor the tub interior with extended use. Check the detergent cup for signs of any discoloration. If cup is discolored, change to detergent without any colorant. Cascade® and Electrasol® Dishwashing Detergents have been approved for use in all Monogram dishwashers. |
| | Some tomato-based foods can stain | <ul style="list-style-type: none"> • Use of the RINSE ONLY cycle after adding the dish to the load can decrease the level of staining. |

Questions?
Use this
problem
solver

| PROBLEM | POSSIBLE CAUSE | WHAT TO DO |
|--|---|---|
| Dishes and flatware not clean | Low inlet water temperature | <ul style="list-style-type: none"> Make sure inlet water temperature is correct (see page 8). |
| | Water pressure is temporarily low | <ul style="list-style-type: none"> Turn on a faucet. Is water coming out more slowly than usual? If so, wait until pressure is normal before using your dishwasher. |
| | Air gap is clogged | <ul style="list-style-type: none"> Clean the air gap. |
| | Improper rack loading | <ul style="list-style-type: none"> Make sure large dishware does not block the detergent dispenser or the wash arms. |
| | No air gap or high drain loop | <ul style="list-style-type: none"> Verify that you have an air gap or a high drain loop. Refer to the Installation Instructions. |
| | Filter needs cleaning | <ul style="list-style-type: none"> The filter assembly must be cleaned regularly to allow the filter to efficiently remove food particles from the wash water. See Cleaning the Filter section on page 13. |
| Spots and filming on glasses and flatware | Extremely hard water | <ul style="list-style-type: none"> Use Jet Dry® or Cascade Crystal Clear® rinse agent to remove spots and prevent new film buildup. |
| | Low inlet water temperature | <ul style="list-style-type: none"> Make sure water temperature is at least 120°F. |
| | Overloading the dishwasher | <ul style="list-style-type: none"> Load dishwasher as shown in the Loading the Dishwasher Racks section. |
| | Improper loading | <ul style="list-style-type: none"> Make sure detergent is fresh. |
| | Old or damp powder detergent | <ul style="list-style-type: none"> If water is extremely hard, a water softener may be required. |
| | Rinse agent dispenser empty | |
| | Too little detergent | |
| Cloudiness on glassware | Combination of soft water and too much detergent | <ul style="list-style-type: none"> This is called <i>etching</i> and is permanent. To prevent this from happening, use less detergent if you have soft water. Wash glassware in the shortest cycle that will get it clean. |
| | Water temperature entering the dishwasher exceeds 150°F | <ul style="list-style-type: none"> Lower the water heater temperature. |
| Black or gray marks on dishes | Aluminum utensils have rubbed against dishes | <ul style="list-style-type: none"> Remove marks with a mild, abrasive cleaner. |
| Yellow or brown film on inside surfaces | Tea or coffee stains | <ul style="list-style-type: none"> Remove the stain by hand, using a solution of 1/2 cup bleach and 3 cups warm water. <p>⚠ WARNING: Before cleaning interior, wait at least 20 minutes after a cycle for the heating element to cool down. Failure to do so can result in burns.</p> |
| | An overall yellow or brown film can be caused by iron deposits in water | <ul style="list-style-type: none"> A special filter in the water supply line is the only way to correct this problem. Contact a water softener company. |

Questions?
Use this
problem
solver

| PROBLEM | POSSIBLE CAUSE | WHAT TO DO |
|---|--|---|
| White film on inside surfaces | Hard water minerals | <ul style="list-style-type: none"> To clean the interior, apply dishwasher detergent to a damp sponge. Wear rubber gloves. Do not use any type of cleanser other than dishwasher detergent because it may cause foaming or sudsing. Cascade® and Electrasol® Automatic Dishwashing Detergents have been approved for use in all Monogram dishwashers. |
| Dishes don't dry | Low inlet water temperature | <ul style="list-style-type: none"> Make sure inlet water temperature is correct (see page 8). |
| | Rinse agent dispenser is empty | <ul style="list-style-type: none"> Check the rinse agent dispenser. |
| Dishwasher won't run | Fuse is blown, or the circuit breaker tripped | <ul style="list-style-type: none"> Replace fuse or reset circuit breaker. Remove any other appliances from the circuit. |
| | Power is turned off | <ul style="list-style-type: none"> In some installations, the power to the dishwasher is proved through a wall switch, often located next to the disposer switch. Make sure it is on. |
| | Reboot your control | <ul style="list-style-type: none"> Turn off power to the dishwasher (at the circuit breaker or wall switch) for 30 seconds; then turn back on. |
| Steam | This is normal | <ul style="list-style-type: none"> Steam comes through the vent during washing, drying and when water is being pumped out. |
| Control panel responded to input but dishwasher never filled with water | Door latch may not be properly seated | <ul style="list-style-type: none"> Make sure the door is firmly closed. |
| | Water valve may be turned off | <ul style="list-style-type: none"> Make sure water valve (usually located under the sink) is turned on. |
| Dishwasher beeps once every 15 seconds | This is normal | <ul style="list-style-type: none"> Close the door after opening it mid-cycle. |
| | This is a reminder that the door has been left open during operation | <ul style="list-style-type: none"> Press ON/OFF to turn OFF the dishwasher. |
| Beeping at the end of the cycle | This is normal | <ul style="list-style-type: none"> The dishwasher will beep and the CLEAN light will display at the end of the wash cycle. |
| LOW RINSE AID light is on | Rinse aid dispenser needs to be refilled | <ul style="list-style-type: none"> This can only be turned off by filling the rinse aid dispenser with Jet-Dry® or Cascade Crystal Clear®. See Refilling the Rinse Aid Dispenser section. |

YOUR MONOGRAM DISHWASHER WARRANTY

Staple sales slip or canceled check here. Proof of original purchase date is needed to obtain service under warranty.

WHAT IS COVERED

From the Date of the Original Purchase

ONE-YEAR

Any part of the dishwasher which fails due to a defect in materials or workmanship. During this limited one-year warranty, GE will also provide, free of charge, all labor and in-home service to replace the defective part.

.....
This warranty is extended to the original purchaser and any succeeding owner for the products purchased for ordinary home use in the 48 mainland states, Hawaii, Washington, D.C. or Canada. If the product is located in an area where service by a GE Authorized Servicer is not available, you may be responsible for a trip charge or you may be required to bring the product to an Authorized GE Service location for service. In Alaska the warranty is the same except that it is LIMITED because you must pay to ship the product to the service shop or for the service technician's travel cost to your home.

All warranty service will be provided by our Factory Service Centers or by our authorized Customer Care® servicers during normal working hours.

Should your appliance need service, during warranty period or beyond, in the U.S.A. call 800.444.1845.

Please have serial number and model number available when calling for service.

EXCLUSION OF IMPLIED WARRANTIES—Your sole and exclusive remedy is product repair as provided in this Limited Warranty. Any implied warranties, including the implied warranties of merchantability or fitness for a particular purpose, are limited to one year or the shortest period allowed by law.

WHAT IS NOT COVERED

- Service trips to your home to teach you how to use the product.
- Improper installation, delivery or maintenance.
- Replacement of house fuses or resetting of circuit breakers.
- Failure of the product if it is abused, misused, or used for other than the intended purpose or used commercially.
- Damage to the product caused by accident, fire, floods or acts of God.
- Incidental or consequential damage caused by possible defects with this appliance.
- Cleaning or servicing of the air gap device in the drain line.
- Damage caused after delivery.
- Product not accessible to provide required service.

Some states do not allow the exclusion or limitation of incidental or consequential damages, so the above limitation or exclusion may not apply to you. This warranty gives you specific legal rights, and you may also have other rights which vary from state to state. To know what your legal rights are in your state, consult your local or state consumer affairs office or your state's Attorney General.

**Warrantor: General Electric Company,
Louisville, KY 40225.**



GE Consumer & Industrial Appliances
General Electric Company
Louisville, KY 40225
ge.com

With the purchase of your new Monogram appliance, receive the assurance that if you ever need information or assistance from GE, we'll be there. All you have to do is call—toll-free!

GE Answer Center®

**In the USA:
800.626.2000**

Whatever your question about any Monogram major appliance, GE Answer Center® information service is available to help. Your call—and your question—will be answered promptly and courteously. And you can call any time. GE Answer Center® service is open 24 hours a day, Monday through Saturday.

OR

Visit our Website at: monogram.com

In Canada, call 1.800.561.3344.

Monogram Preferred Service

**In the USA:
800.444.1845**

**In Canada:
1.800.561.3344**

A GE consumer service professional will provide expert repair service, scheduled at a time that's convenient for you. Many GE Consumer Service company-operated locations offer you service today or tomorrow, or at your convenience (7:00 a.m. to 10:00 p.m. weekdays, 8:00 a.m. to 6:00 p.m. Saturday and Sunday). Our factory-trained technicians know your appliance inside and out—so most repairs can be handled in just one visit.

For Customers With Special Needs...

**In the USA:
800.626.2000**

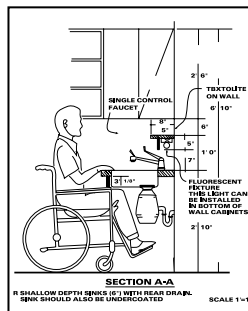

GE offers Braille controls for a variety of GE appliances, and a brochure to assist in planning a barrier-free kitchen for persons with limited mobility.

Consumers with impaired hearing or speech who have access to a TDD or a conventional teletypewriter may call 800.TDD.GEAC (800.833.4322) to request information or service.

Service Contracts

**In the USA:
800.626.2224**

**In Canada:
1.800.561.3344**

You can have the secure feeling that GE Consumer Service will still be there after your warranty expires. Purchase a GE contract while your warranty is still in effect and you'll receive a substantial discount. With a multiple-year contract, you're assured of future service at today's prices.

Parts and Accessories

**In the USA:
800.626.2002**

**In Canada:
1.800.561.3344**

Individuals qualified to service their own appliances can have parts or accessories sent directly to their home. The GE parts system provides access to over 47,000 parts...and all GE Genuine Renewal Parts are fully warranted. VISA, MasterCard and Discover cards are accepted.

User maintenance instructions contained in this manual cover procedures intended to be performed by any user. Other servicing generally should be referred to qualified service personnel. Caution must be exercised, since improper servicing may cause unsafe operation.

Consumer Product Ownership Registration

Important Mail Today

GE Appliances

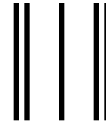

Place
1st Class
Letter
Stamp
Here

General Electric Company
Warranty Registration Department
P.O. Box 34980
Louisville, KY 40232-2150

Consumer Product Ownership Registration

Dear Customer:

Thank you for purchasing our product and thank you for placing your confidence in us. We are proud to have you as a customer!

Follow these three steps to protect your new appliance investment:



1

Complete and mail your Consumer Product Ownership Registration today. Have the peace of mind of knowing we can contact you in the unlikely event of a safety modification.

2

After completing this registration, write your model and serial numbers in this manual and store this document in a safe place. You will need this information should you require service. The service number in the USA: 800.444.1845. In Canada: 1.888.880.3030.

3

Read your "Owner's Manual" carefully. It will help you operate your new appliance properly.

Important: If you did not get a registration card with your product, detach and return the form below to ensure that your product is registered, or register online at monogram.com.

FOLD HERE

Consumer Product Ownership Registration



| <u>Product</u> | <u>Model Number</u> | <u>Serial Number</u> |
|----------------|---------------------|----------------------|
| Dishwasher | | |

Mr. Ms. Mrs. Miss

First Name _____ Last Name _____

Street Address _____

Apt. # _____ E-mail Address* _____

City _____ State _____ Zip Code _____

Date Placed In Use _____
Month _____ Day _____ Year _____
Phone Number _____-_____-_____



GE Consumer & Industrial Appliances
General Electric Company
Louisville, KY 40225
ge.com

* Please provide your e-mail address to receive, via e-mail, discounts, special offers and other important communications from GE Appliances (GEA).
 Check here if you do not want to receive communications from GEA's carefully selected partners.
FAILURE TO COMPLETE AND RETURN THIS CARD DOES NOT DIMINISH YOUR WARRANTY RIGHTS.
For information about GEA's privacy and data usage policy, go to monogram.com and click on "Privacy Policy" or call 800.626.2224.



TAPE CLOSED

165D4700P370
49-55045

05-08 JR
Printed in the United States



GE Consumer & Industrial Appliances
General Electric Company
Louisville, KY 40225
ge.com