

AUTOMATIC DISHWASHER

Models
712M 812E 813E 912T
913T



PRODUCTS

Brand Fisher & Paykel, Frigidaire, Kelvinator

Voltage 220-240V 50Hz

Model	Code
712M	85579 86769
812E	85578 86768 87177
813E	85581 86771 87178 87199
912T	85577 86767 87025 87176
913T	85580 86770 87197 87198 88134

Fisher & Paykel Customer Services
 PO Box 798
 19 Enterprise St
 Cleveland, Queensland 4163
 Australia
 Tel: (07) 3826 9122
 Fax: (07) 3826 9164
 Email: parts@fp.com.au
 A.C.N 003 335 171

Fisher & Paykel Appliances Ltd
 Appliance Spare Parts
 PO Box 14-148, Panmure.
 80 Springs Rd, East Tamaki
 New Zealand
 Tel: (09) 272 0261
 Fax: (09) 272 0219
 Email: parts@fp.co.nz

CONTENTS

DOOR PANELS AND CONTROLS.....	6
CABINET.....	12
SUMP AND PUMPS	18
BASKETS AND SPRAY ARMS	22
NOTES	25

GUIDE TO USING THIS MANUAL

The model(s) and/or series covered by this manual are listed on the front cover.

The information detailed in this manual is subject to change without notice, the latest version is indicated by the reprint date and replaces any earlier editions.

The front cover picture shows the type of product and may not necessarily be an exact image of the models covered by the manual.

Part References

Where a Model is shown, the part is exclusive to the Model(s) stated. Common parts relating to a part reference are applicable to all other Model(s) which use the particular item.

Kit Parts

The components shown in *italics* are those parts in the kit which are available also as separate items. In addition, some parts may be supplied with this kit which are not available as separate items and are therefore not listed in this manual.

All details relating to Technical Bulletins or Notes are shown on a dedicated page. The Technical Bulletin Number shown relates to the bulletin version which is produced for New Zealand Service Centres.

Parts List Key

NOT USED	As a part, indicates the diagram part reference is not used in this manual.
#	Beside the part number, indicates the part is no longer available.
<i>italics</i>	Kit components shown in <i>italics</i> are also available separately.
*	Indicates a technical bulletin or note exists for the part or part reference.
NI	As a part reference, indicates the part is not illustrated on the diagram.

DOOR PANELS AND CONTROLS

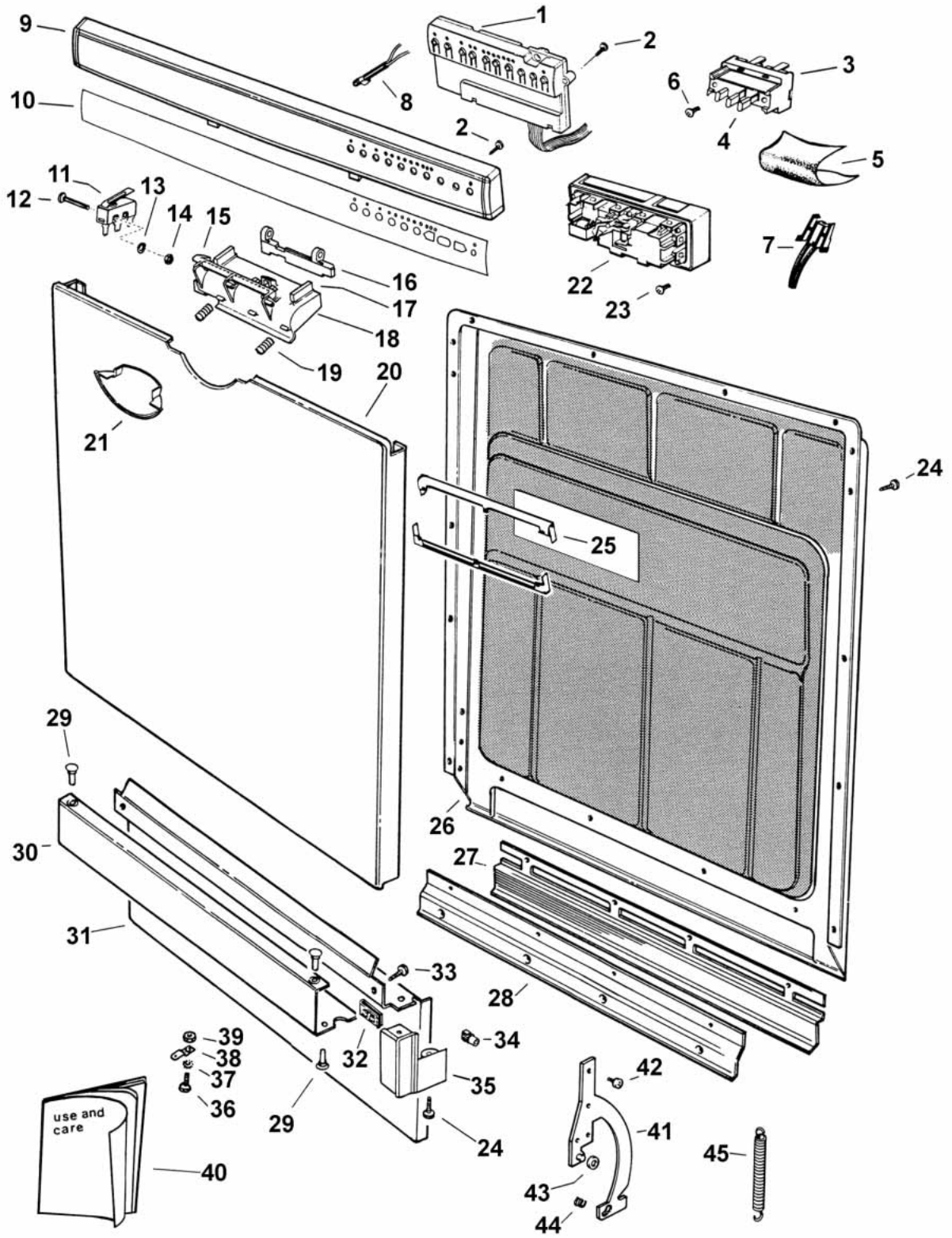

DOOR PANELS AND CONTROLS

REF	PART	DESCRIPTION	MODEL
1	521272P	CONTROLLER CONSOLE 813T	812E
	521272P	CONTROLLER CONSOLE 813T	813E
	521271P	CONTROLLER CONSOLE 913T	912T
	521271P	CONTROLLER CONSOLE 913T	913T
2	556068	SCREW ST K35 X 13 PT MTS TX SS	
3	473557	SWITCH 3 BUTTON NZC GD3-201A	712M
4	473599	BUTTON SWITCH NZC CORAL	
	473600	BUTTON SWITCH NZC LIGHT SIERRA	
5	473566	SHIELD SWITCH 3886	
6	556003	SCREW ST 6X3/8 T25 PAN PH NP	
7	473741	SENSOR ASSY TEMPERATURE	
8	471163	NEON ASSY	712M
9	521133	HANDLE MOULDING 3887M GREY	712M
	521130	HANDLE MOULDING 3887E WHITE	812E
	521131	HANDLE MOULDING 3887E GREY	812E
	521130	HANDLE MOULDING 3887E WHITE	813E
	521131	HANDLE MOULDING 3887E GREY	813E
	521127	HANDLE MOULDING 3887T WHITE	912T
	521128	HANDLE MOULDING 3887T GREY	912T
	521127	HANDLE MOULDING 3887T WHITE	913T
	521128	HANDLE MOULDING 3887T GREY	913T
10	521122	INSERT HANDLE KELV 712M WG	712M
	521124	INSERT HANDLE FRIG 712M WG	712M
	521237	INSERT HANDLE F&P 813E WW	813E
	521238	INSERT HANDLE KELV 813E WG	813E
	521239	INSERT HANDLE FRIG 813E WG	813E
	521234	INSERT HANDLE F&P 913T WW	912T
	521236	INSERT HANDLE FRIG 913T WG	912T
	521234	INSERT HANDLE F&P 913T WW	913T
	521236	INSERT HANDLE FRIG 913T WG	913T
11	274002	MICROSWITCH LID AW & DOOR DW	
12	556051	SCREW MC M3X20 PAN PH MS NP	
13	556512	WASHER LOCK 3MM EXT SERR ST BU	
14	556103	NUT M3 HEX FS MS NIPL	
15	521291	LEVER MICROSWITCH 3887	
16	521065	PIVOT LATCH 3887	
17	521089	STOP LATCH	

DOOR PANELS AND CONTROLS

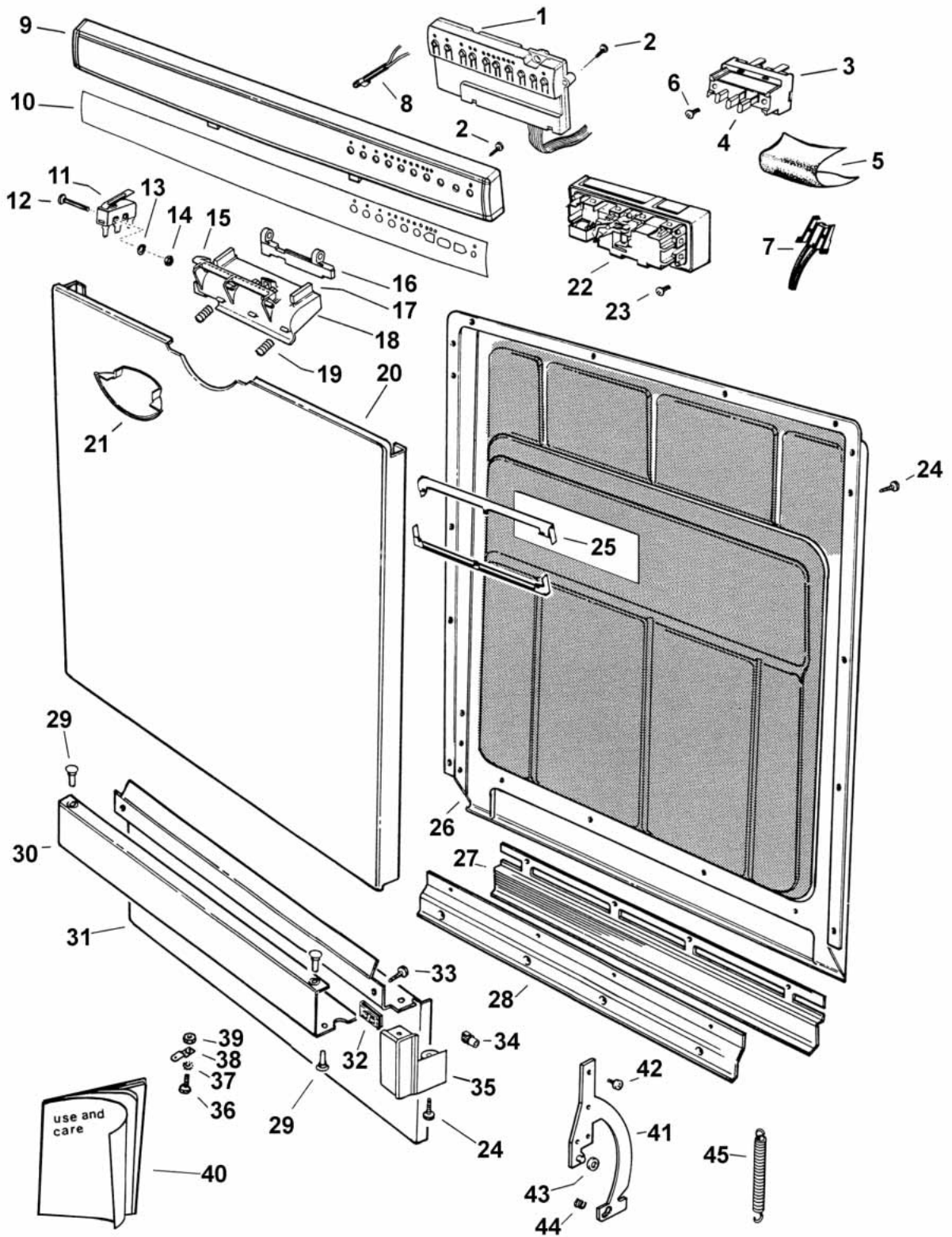

DOOR PANELS AND CONTROLS

REF	PART	DESCRIPTION	MODEL
18	521046	LATCH HANDLE 3887 WHITE	
19	521047	SPRING LATCH 3887	
20	521250	DOOR OUTER PANEL SOUND DEADEND	
21	521011	RECESS LATCH WHITE	
22	473565	DISPENSER D/RA ELBI 540.50500	
		<i>502091 LID RINSE AID</i>	
		<i>502156 COIL</i>	
		<i>502157 LID DETERGENT</i>	
		<i>502161 PLUNGER</i>	
		<i>502162 CAP PLUNGER</i>	
*	521269	DISPENSER D/RA ELTEK 100418.46	
		<i>521322 LID ELTEK 25.0567.00</i>	
		<i>521323 O RING ELTEK 26.0163.00</i>	
		<i>521324 THERMO ACTUATOR ELTEK 10033130</i>	
		<i>521325 CAP FILLER ELTEK 25.0568.00</i>	
		<i>521326P LATCH & O RING</i>	
		<i>521327 O RING ELTEK 26.0164.00</i>	
23	556086	SCREW ST 3.5X12.7 PLAS PNPZ ZP	
24	556007	SCREW ST 8X12MM TA MTS PH SS	
25	521270	BRACKET FIXING ELTEK 100348.02	
26	* 521275	DOOR INNER PANEL SOUND DEADEND	
27	388220	MOAT BAFFLE	
28	388223	MOAT SPLASHGUARD	
29	521082	CLIP DECORATIVE PANEL WHITE	
30	521006	PANEL DECORATIVE WH (SERVICE)	
31	521005	PANEL SERVICE WHITE	
32	556102	NUT CAPTIVE NO8 SPIRE SNU 3381	
33	556036	SCREW ST 8X10MM TAB MTS PH NP	
34	521080	PEG SERVICE PANEL 3887	
35	521104	ENDCAP DECOR PANEL LH WHITE	
	521105	ENDCAP DECOR PANEL RH WHITE	
36	556018	SCREW MC M4X8 HEX PH MS NP	
37	556513	WASHER LOCK 5/32 EXT SER ST BU	
38	461571	TERM EARTH H1889ET	
39	556104	NUT M4 HEX FS MS NIPL	
40	521314	BOOK USE & CARE 712M	712M
	521145	BOOK USE & CARE	812E

DOOR PANELS AND CONTROLS

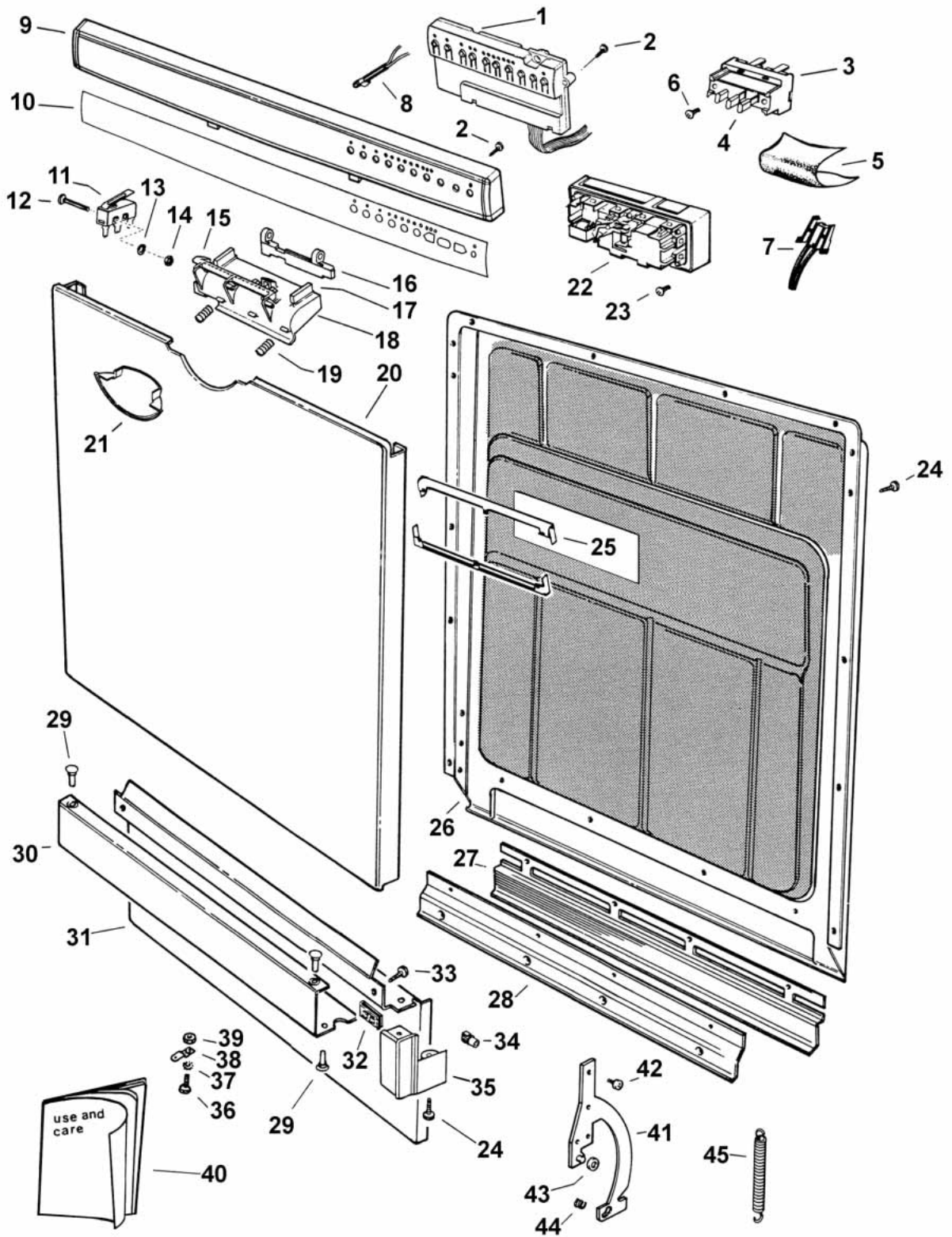

DOOR PANELS AND CONTROLS

REF	PART	DESCRIPTION	MODEL
40	521313	BOOK USE & CARE 813E	813E
	521312	BOOK USE & CARE 913T	912T
	521312	BOOK USE & CARE 913T	913T
41	521357	KIT HINGE QUADRANT (RIVET) LH	
	521358	KIT HINGE QUADRANT (RIVET) RH	
42	556042	SCREW MC M5X10 PAN PH SS	
43	556508	WASHER 7.2 12.7 1.0 NYLON	
44	404045	GROMMET HINGE QUADRANT	
45	388824	SPRING HINGE	
NI	521310	LABEL WIRING DIAGRAM 712M	712M
	521106#	LABEL WIRING DIAGRAM	812E
	521309#	LABEL WIRING DIAGRAM	813E
	521103#	LABEL WIRING DIAGRAM	912T
	521308	LABEL WIRING DIAGRAM 913T/813E	913T
NI	521315	CARD INSTAL INSTR 913T813E712M	
NI	* 521317	KIT ELBI DISPENSER SECURING	
		<i>521277 BRACKET FIXING ELBI DISPENSER</i>	
		<i>556003 SCREW ST 6X3/8 T25 PAN PH NP</i>	

CABINET

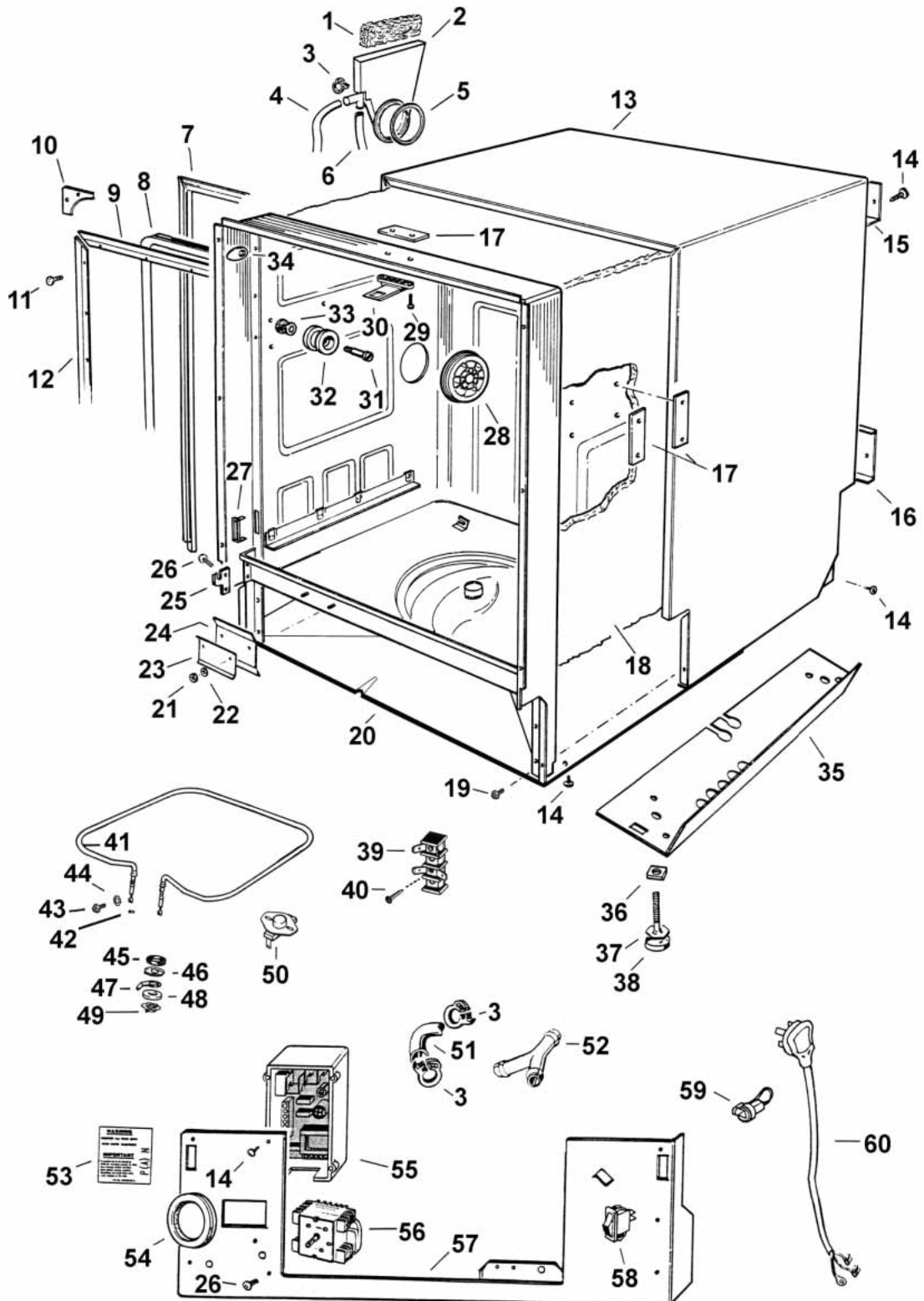

CABINET

REF	PART	DESCRIPTION	MODEL
1	521100	GAUZE FILL VENT	
2	521031	FILL VENT WELDED ASSY	
3	473677	CLAMP HOSE HERBIE TYPE F	
4	521096	HOSE VENT / WEIR / DRAIN	
5	521033	SEAL FILL VENT	
6	521107	HOSE FILL LONG 3887	712M
	521107	HOSE FILL LONG 3887	813E
	473371	HOSE FILL (3885/6S)	912T
	473371	HOSE FILL (3885/6S)	913T
7	521053	GASKET SOUND	
8	473543	GASKET DOOR DW	
9	388353	RETAINER GASKET UPPER	
10	473555	GUSSET GASKET CORNER RH	
	473556	GUSSET GASKET CORNER LH	
11	556007	SCREW ST 8X12MM TA MTS PH SS	
12	388370	RETAINER GASKET RH	
	388371	RETAINER GASKET LH	
13	521000	WRAPPER CABINET	
14	611979P	SCREW ST 8X3/8 TAB MUSH PH X10	
15	521069	PANEL REAR TOP 3887	
16	521070	PANEL REAR BOTTOM 3887	
17	388255	PLATE TAPPING	
18	521091	SOUND ABSORBER BLANKET	
19	556036	SCREW ST 8X10MM TAB MTS PH NP	
20	521024	COVER CHASSIS	
21	556104	NUT M4 HEX FS MS NIPL	
22	556506#	WASHER 5/32X7/16 20BG MS NIPL	
23	388228	CLAMP WIRING	
24	521129	INSULATOR STRIP 3887	
25	521003	HINGE PLATE PRESSING	
26	556045	SCREW MC M5X8 PAN PH MS NP	
27	521193	GUIDE QUADRANT GREY	
28	521032	CAP FILL VENT	
29	* 556042	SCREW MC M5X10 PAN PH SS	
	556070	SCREW MC M5X12 PAN PH SS	
30	521290	TONGUE LATCH 3887	
31	388245	ROLLER STUD TUB	

CABINET

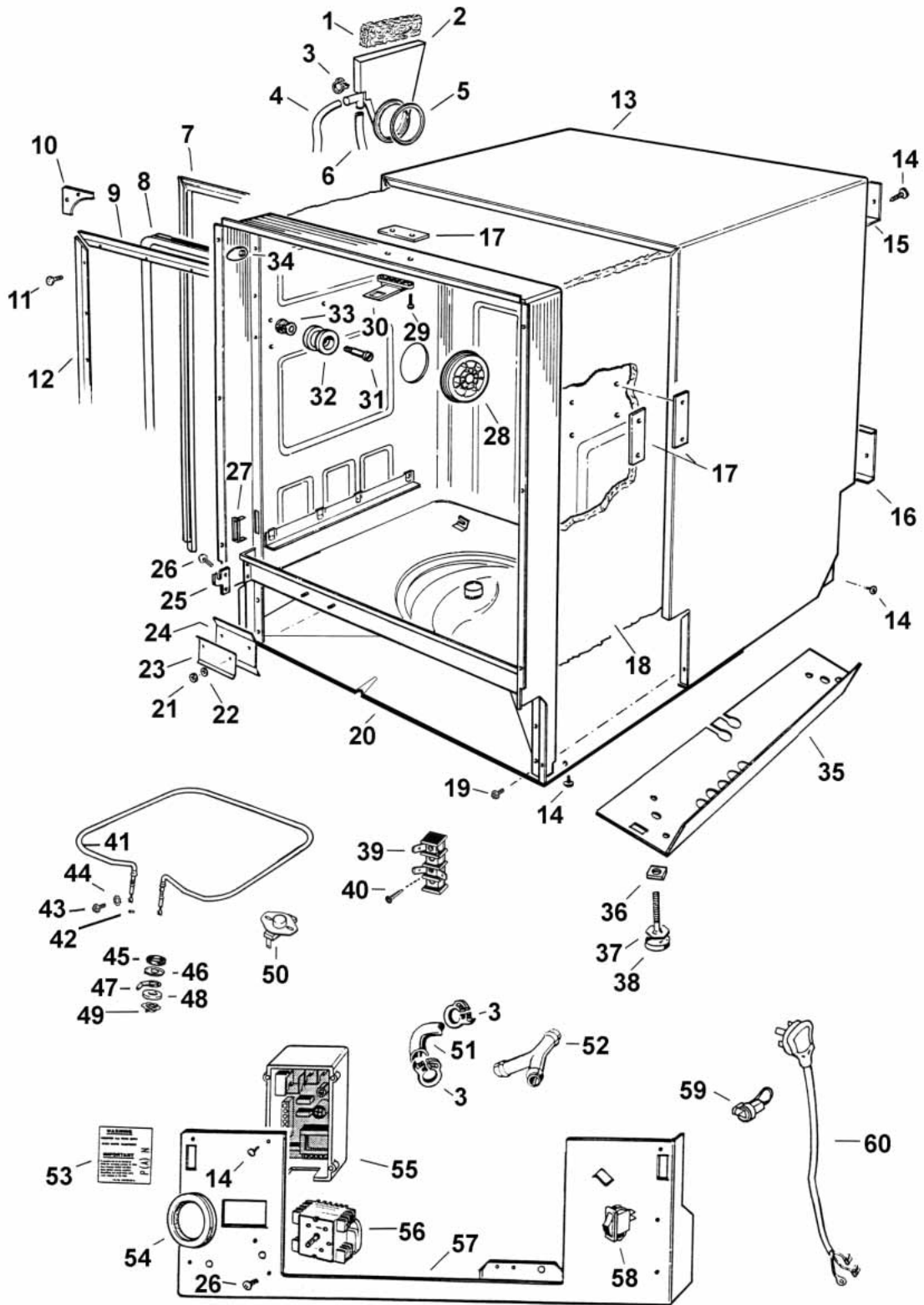

CABINET

REF	PART	DESCRIPTION	MODEL
32	521187	ROLLER TUB GREY	
33	556505	WASHER 5.3 15.0 BONDED SS/RUBR	
34	521090	BUFFER FRAME	
35	521004	CHASSIS SIDE MEMBER RH	
	521066	CHASSIS SIDE MEMBER LH	
36	556109	NUT M8 SQ HS PRESS MS NIPL	
37	473059	FOOT LEVELLING M8	
38	572850	FOOT PROTECTOR M8	
39	473796	TERMINAL BLOCK	
40	556037#	SCREW ST 8X5/8 TAB PAN PH HS NIPL	
41	521343	ELEMENT ASSY 3886/7 (SPARES)	
		<i>556018 SCREW MC M4X8 HEX PH MS NP</i>	
		<i>556513 WASHER LOCK 5/32 EXT SER ST BU</i>	
	* 521380	ELEMENT ASSY 913	
		<i>521381 ELEMENT GASKET 913</i>	
		<i>521389 ELEMENT RETAINING PLATE 913</i>	
		<i>556113 NUT 1/4UNC HEX FS MS NIPL</i>	
42	388758	O RING	
43	556018	SCREW MC M4X8 HEX PH MS NP	
44	556513	WASHER LOCK 5/32 EXT SER ST BU	
45	556501	WASHER 12.7 28.7 2.0 MS NIPL	
46	388727	WASHER CUP(ELEMENT)	
47	473202	TERM EYELET H3579ET	
48	556502	WASHER 16.2 30.5 4.7 ELASTOPRN	
49	556110	NUT SPEED GE 218A2533P04	
50	* 388847	THERMOSTAT 45DEG	
	388848	THERMOSTAT 59DEG	
	521374	THERMOSTAT O/HEAT 85C AUTO RST	
	521385	KIT THERMOSTAT MAN-AUTO RESET	
51	521098	HOSE FILL SHORT 3887	
52	404831	Y UNION	
53	521113#	LABEL WARNING	
54	473109	GROMMET UNIVERSAL BRACKET	
55	473743	PCB POWER REBUILT/EXCHANGE	
56	473542	TIMER MICROCYCLE 3886/7M	712M
		<i>274784# MOTOR TIMER</i>	
57	521021	BRACKET CHASSIS FRONT	

CABINET

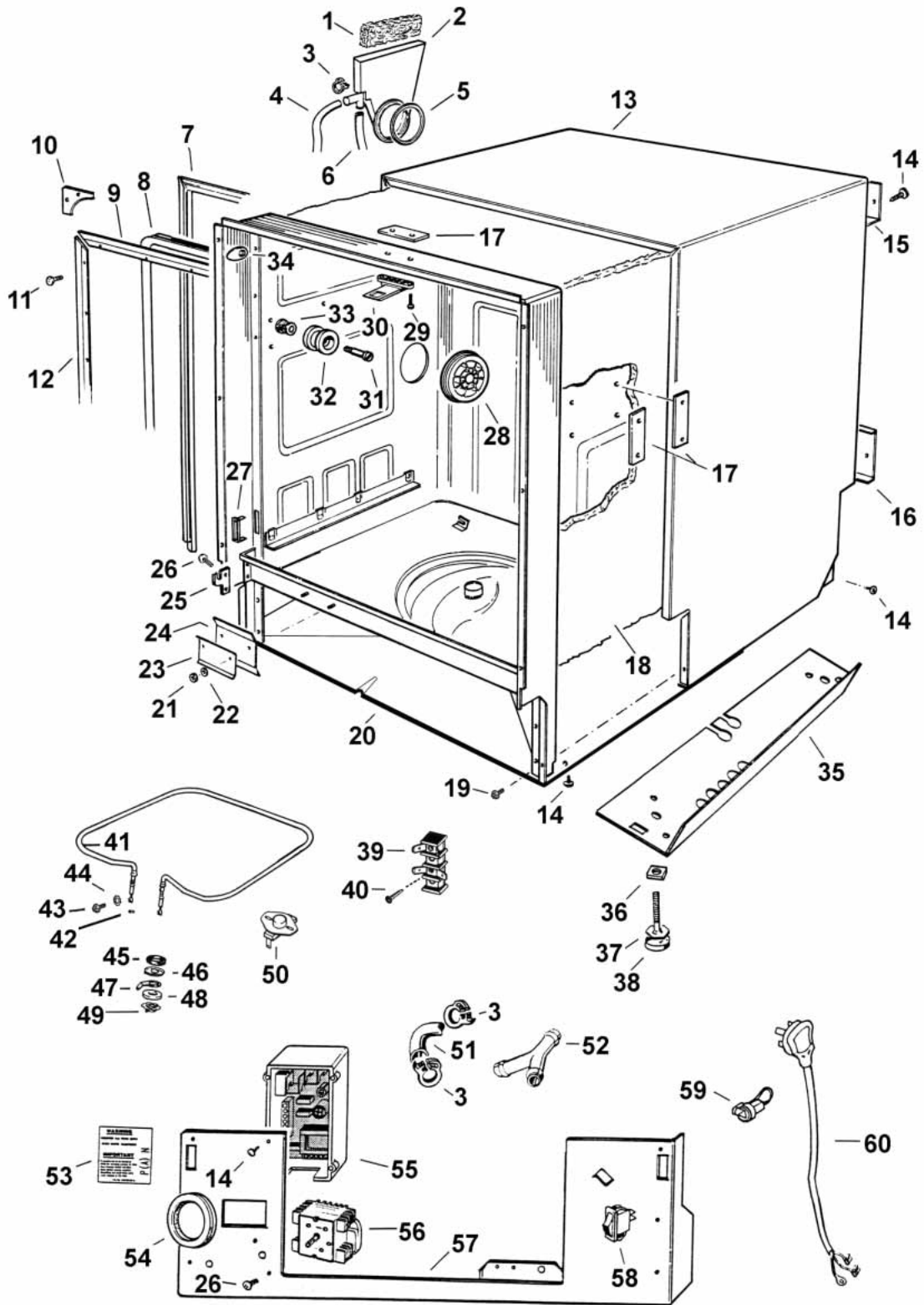

CABINET

REF	PART	DESCRIPTION	MODEL
57	521363	BRACKET CHASSIS REAR	
58	572392	SWITCH OUTLET (SIGNALUX) BROWN	
59	388652	GROMMET CORD GRIP Q6543	
60	473608	FLEX ASSY MAINS 10A 3886/7	
NI	473822	LABEL DUAL/SINGLE VALVE (3886)	
NI	404304#	BRACKET FLOOR	

SUMP AND PUMPS

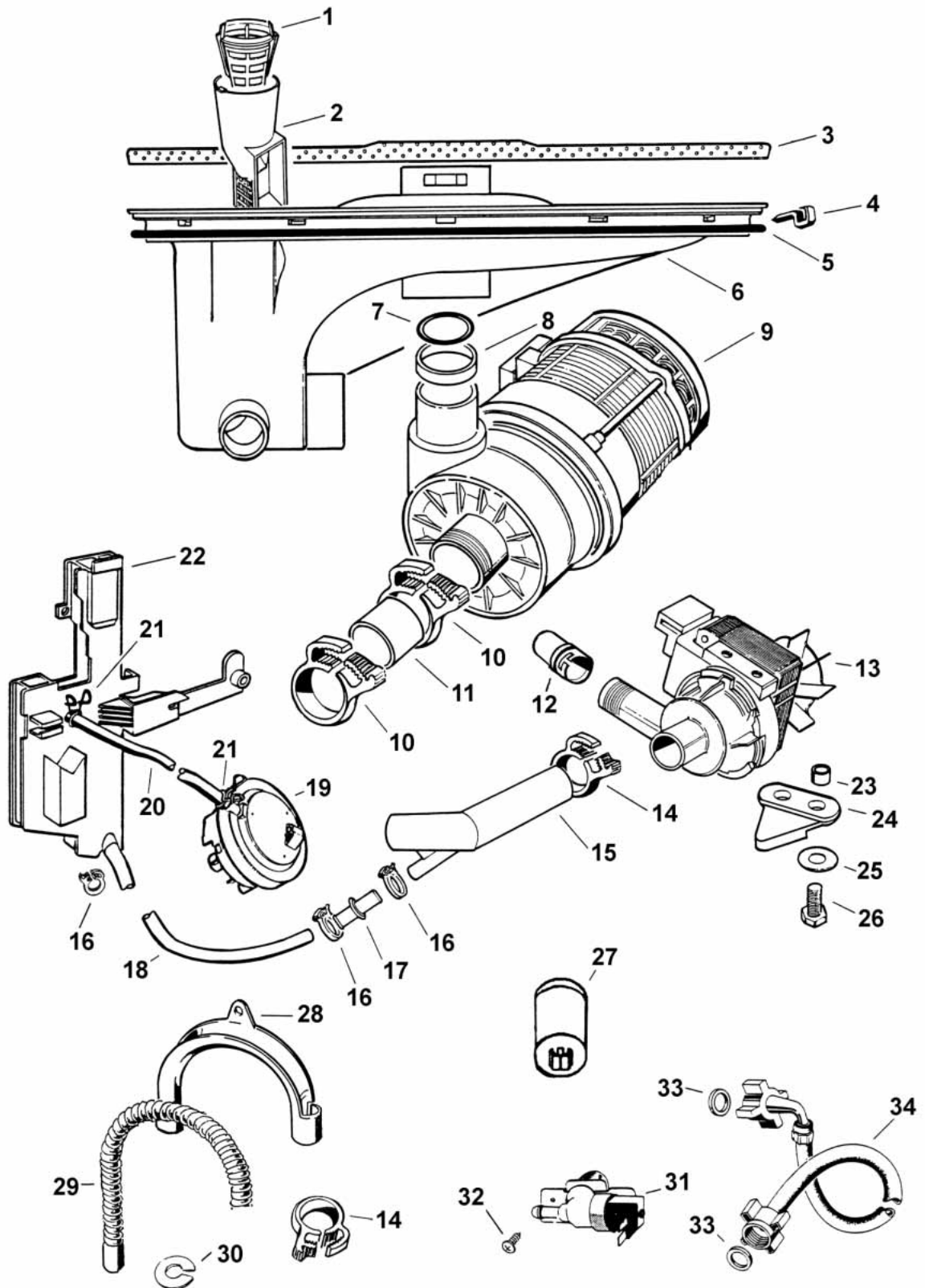

SUMP AND PUMPS

REF	PART	DESCRIPTION	MODEL
1	521185	STRAINER GREY	
2	521056	FUNNEL FILTER	
3	521014	PLATE FILTER 3887	
4	388898	WEDGE SUMP	
5	473816	O RING SUMP	
6	521008	SUMP MOULDING 3887	
7	521071	O RING WASH PUMP/FLOW DIVIDER	
8	521723	SPACER WASH PUMP OUTLET SHORT	
9	* 521372	KIT HANNING PUMP CONVERSION	
		<i>521364 PUMP WASH HANNING CP-40-102</i>	
		<i>521369 BRACKET PUMP CONVERSION</i>	
		<i>521371 CAPACITOR</i>	
		<i>611979P SCREW ST 8X3/8 TAB MUSH PH X10</i>	
10	473641	CLAMP HOSE HERBIE TYPE S	
11	388891	HOSE WASH PUMP INLET	
12	521084	VALVE NON RETURN ASSY	
13	521062	PUMP DRAIN HANNING 661 039 009	
14	473678	CLAMP HOSE HERBIE TYPE M	
15	521044	HOSE SUMP/DRAIN	
16	473677	CLAMP HOSE HERBIE TYPE F	
17	521052	CONNECTOR HOSE 8MM	
18	521096	HOSE VENT / WEIR / DRAIN	
19	521038	PRESSURE SWITCH 3887	
20	521023	HOSE PRESSURE SWITCH 3887	
21	425611	CLAMP HOSE 08.5 TALL GRIP	
22	521029	WEIR CHAMBER WELDED ASSY	
23	521027	SPACER PUMP MOUNTING	
24	521083	MOUNTING PUMP	
25	556507	WASHER 6.5 19.0 0.8 MS NIPL	
26	556017	SCREW MC M6X16 HEX FS MS NP	
27	521025	CAPACITOR	
28	473352	SUPPORT DRAIN HOSE	
29	473345	HOSE DRAIN	
	521287	HOSE DRAIN LONG (SPARES ONLY)	
30	473347	COLLAR DRAIN HOSE	
31	521545	VALVE INLET 5L ELTEK 100500.13	
32	556018	SCREW MC M4X8 HEX PH MS NP	

SUMP AND PUMPS

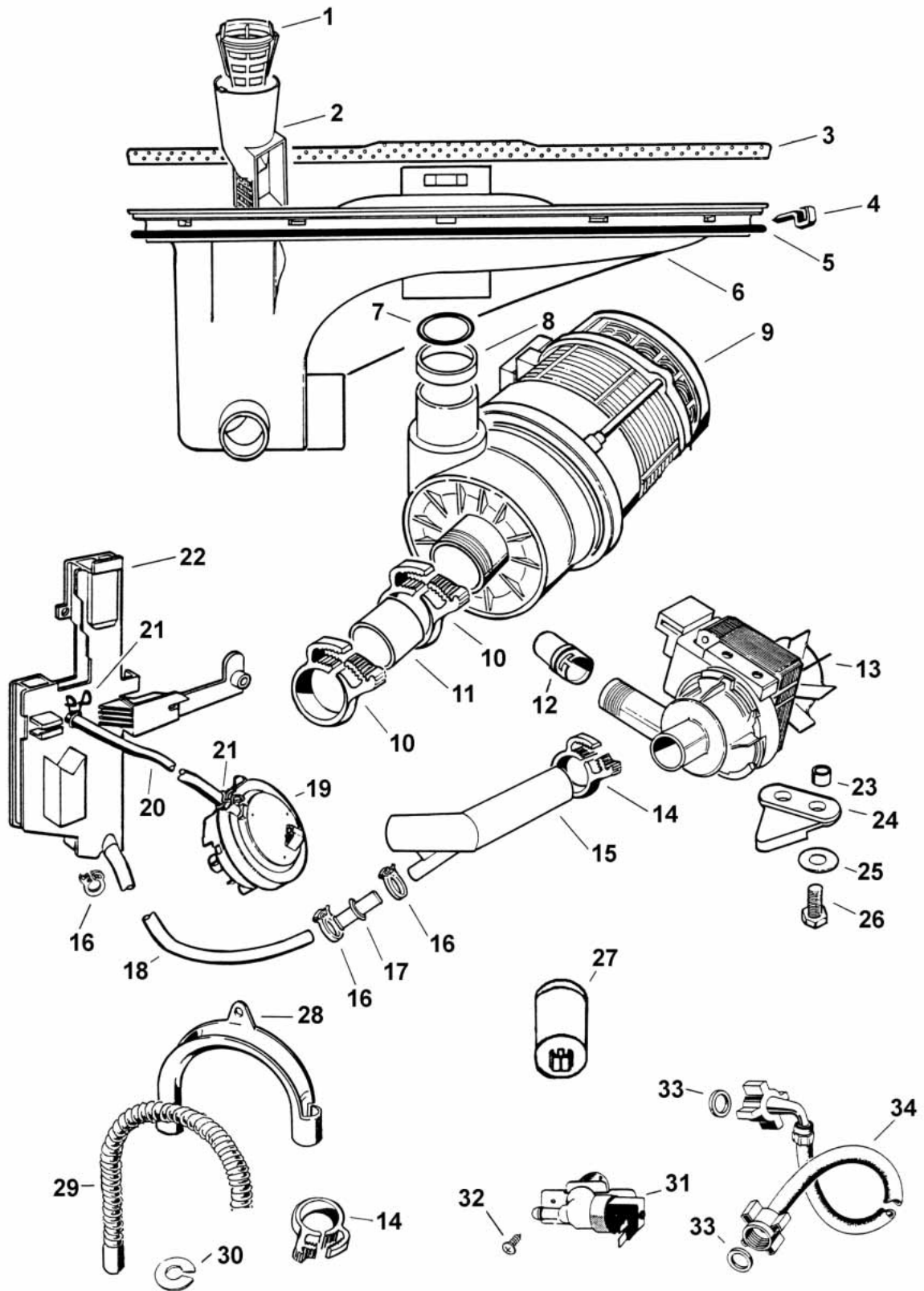

SUMP AND PUMPS

REF	PART	DESCRIPTION	MODEL
33	400704	CONNECTOR SEAL	
34	521348	HOSE INLET ASSY WIRSBO HOT	
	521349	HOSE INLET ASSY WIRSBO COLD	

BASKETS AND SPRAY ARMS

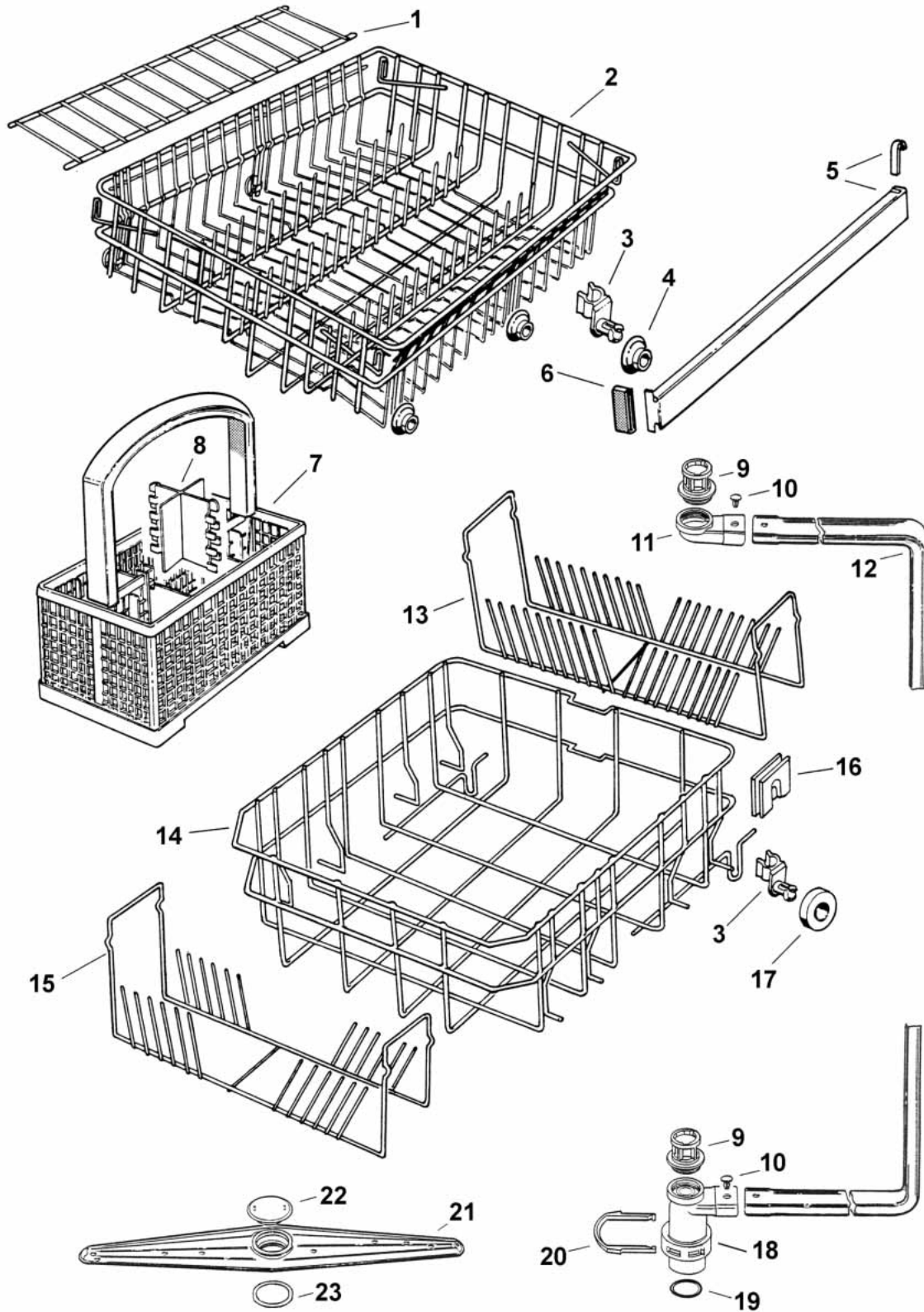

BASKETS AND SPRAY ARMS

REF	PART	DESCRIPTION	MODEL
1	473568	RACK GLASS RETAINING WHITE	
	521176	RACK GLASS RETAINING GREY	
2	521175	BASKET ASSY TOP CROCK 3887 GY	
3	473060	ROLLER STUD WHITE	
	521337	AXLE STUB GREY	
4	521191	ROLLER BASKET GREY	
5	521373A	RAIL & CLIPS ASSEMBLY	
	521332	<i>CAP RAIL TOP BASKET GREY</i>	
	521373	<i>RAIL TOP BASKET</i>	
6	521189	CAP RAIL TOP BASKET GREY	
7	521051P	BASKET CUTLERY WHITE	
	521172	CUTLERY BASKET ASSY 3887 GREY	
8	521170	DIVIDER CUTLERY BASKET WHITE	
	521171	DIVIDER CUTLERY BASKET GREY	
9	521035	BEARING SPRAY ARM	
10	521015	PIN LOCKING	
11	521013	TOP TRANSITION	
12	521335	PLUMBING W/ASSY (PURCHASED)	
13	521060	BASKET INSERT ASSY BACK WHITE	
	521179	BASKET INSERT ASSY BACK GREY	
14	521058	BASKET ASSY LOWER 3887 WHITE	
	521177	BASKET ASSY LOWER 3887 GREY	
15	521059	BASKET INSERT ASSY FRONT WHITE	
	521178	BASKET INSERT ASSY FRONT GREY	
16	473147	BUFFER STOP WHITE	
	521183	BUFFER STOP GREY	
17	521180	ROLLER LOWER BASKET 3887 WHITE	
	521181	ROLLER LOWER BASKET 3887 GREY	
18	521034	FLOW DIVIDER	
19	521071	O RING WASH PUMP/FLOW DIVIDER	
20	521036	CLIP FLOW DIVIDER	
21	521067	BOTTOM SPRAY ARM ASSY	
	521068	TOP SPRAY ARM ASSY	
22	521055	RETAINER SPRAY ARM	
23	* 521360	WASHER SPRAY ARM BEARING	

NOTES

DOOR PANELS AND CONTROLS

Technical Bulletins

26	DW55
521269	DW55
521317	DW55

CABINET

Technical Bulletins

29	DW64
50	DW71
521380	DW73

SUMP AND PUMPS

Technical Bulletins

9	DW71
---	------

BASKETS AND SPRAY ARMS

Technical Bulletins

23	DW70
----	------