

### AIR CLEANERS/FILTERS

### HEPA CENTRAL AIR FILTRATION SYSTEM HOMEOWNERS MANUAL & DEALER INSTALLATION INSTRUCTIONS FOR MODELS 350 & 675

#### Rules for Safe Installation and Operation

##### READ AND SAVE THESE INSTRUCTIONS!

Please read instructions before installing and using the HEPA Central Air Filtration System (HEPA system). This will help you obtain the full benefit of the HEPA system you have selected. It will also help you to avoid needless service costs.

1. Read this manual carefully. Failure to follow these rules and instructions could cause a malfunction of the air filter or unsatisfactory service and could void your warranty.
2. Follow a regular service and maintenance schedule to ensure efficient operation.
3. For safety and optimized performance of your HEPA system, all installation and maintenance must be performed by a professional heating and ventilation contractor. The installer should be made aware of your indoor air quality situation and be familiar with your heating, ventilation and air conditioning equipment.
4. High particulate distribution may occur during initial start-up of this product after installation or after scheduled filter changes. Individuals who are highly sensitive to airborne particulates should not be in the building and allow 24 hours of operation for removal of particulates from occupied spaces before re-entry.

#### **⚠ WARNING**

##### **Risk of property damage, injury or death.**

Installation, adjustments, alterations, service and maintenance must be performed by a qualified technician.

##### **Risk of Carbon Monoxide Poisoning.**

Can cause injury or death. Do not operate equipment without access panel in place. Operation of this equipment without all access panels in place may cause gas fumes from the heating system to be drawn into occupied spaces.

#### Shipping and Packing List

Package 1 of 1 contains:

- 1 - HEPA System
- 1 - Complete Filter Set (Packed inside Unit)
- 1 - Installation Kit
- 1 - Installation Instructions (this manual)
- 1 - Registration Card
- 1 - Warranty Statement

#### HEPA System Models

Model 350 is designed to filter air up to a rate of 350 cfm.

Model 675 is designed to filter air up to a rate of 675 cfm.

#### Table of Contents

Rules for Safe Installation and Operation.....	1
Shipping and Packing List .....	1
Introduction .....	2
General Information .....	2
Product Application Guidelines .....	2
Parts Identification .....	3
Physical Dimensions of Units .....	3
Dealer Installation Instructions.....	4-6
Operation .....	6
Maintenance.....	7
Filter Change Schedule.....	7
Filter Changing Guidelines .....	7
Dealer Filter Change Instructions .....	8
Dealer Motor Assembly Replacement Instructions .....	9
Electrical Diagram.....	9
Beam Central HEPA Air Filtration Systems Item List.....	10
Part Inventory .....	11

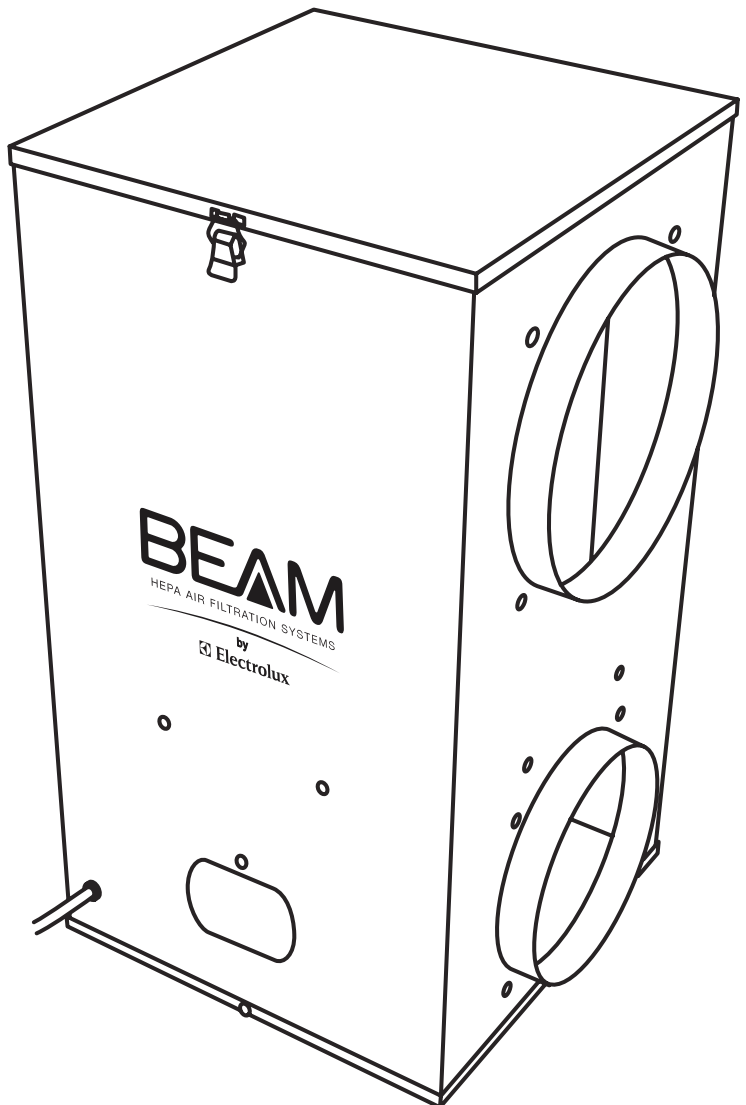

## Introduction

Congratulations! You will quickly realize that you have purchased a very effective air cleaning system. It incorporates state of the art HEPA (High Efficiency Particulate Air) technology.

Your HEPA system comes with a limited warranty. With proper attention to its care and maintenance, you will receive optimum performance.

If your indoor air has abnormally high concentrations of particulates, the life span of the filter media may be shortened. Excessive particulates in the air will reduce the expected life of the HEPA filter. Under normal conditions the HEPA filter will last from two to five years.

Initially, the HEPA filter's particulate removal efficiency improves with use. However, the air flow through the HEPA filter media will decrease, as dust builds up on the filter, thus lowering its ability to circulate and clean as much air as when it was new. If the air flow through your unit is noticeably reduced, you can inspect the pre-filter and HEPA filter to see if they should be replaced. Replacement (or washing if foam) of the prefilter every 3 months will help extend the life of the HEPA filter. Please contact your local Beam dealer regarding replacement of filter media, warranty information or if you have any questions or concerns about the performance of your HEPA system.

NOTE: This filtration system is an ADDITIONAL filter, and does NOT replace the existing air handler/furnace system filter.

## General Information

### Media Filters

Media filters strain particulates from the air. The filter media needs to have tiny holes to allow air to pass through, but not particulates. Filter types vary for all sorts of purposes. The most effective and proven filter media is HEPA. HEPA filter media is 99.97% efficient at capturing particles which are 0.3 micron in size or larger.

### Carbon Filters

Carbon media is used to capture chemicals and odors, also referred to as V.O.C.'s. Chemicals and odors cannot be captured with media type filters. Activated carbon collects chemicals and odors in a process called adsorption.

## Product Application Guidelines

### Size of house vs. Air Changes per Hour

Model Unit	1,000 ft2 (8,000 ft3)	1,200 ft2 (9,600 ft3)	1,500 ft2 (12,000 ft3)	1,800 ft2 (14,400 ft3)	2,000 ft2 (16,000 ft3)	2,500 ft2 (20,000 ft3)	3,000 ft2 (24,000 ft3)	3,500 ft2 (28,000 ft3)
350	2.4	2.0	1.6	1.4	1.2	1.0	0.8	0.7
675	5.0	4.2	3.4	2.8	2.5	2.0	1.7	1.5

Chart based on homes with 8ft. ceilings.

#### Notes:

- Industry experience indicates that one (1) air change per hour generally provides adequate air cleaning. Actual results will depend on multiple factors such as outdoor particulate levels, infiltration rate, indoor activities etc.
- Generally speaking, the more air changes per hour provided, the more effective a HEPA system will be. People with sensitivities may desire a higher number of air changes per hour for cleaner air.

If air passes through the carbon filter before particulates are removed, the surface of the carbon quickly gets covered with particulates, rendering it ineffective at capturing chemicals and odors. If particulates are removed from the air with a HEPA filter, virtually the entire surface area of the carbon can be used to capture chemicals and odors. This increases the efficiency and filter life of the carbon filter.

### Separate HEPA and Carbon Filters

HEPA and carbon filters have different life spans. It is important for a filtration system to keep the filter components independent from each other, so that the filter that is dirty/saturated can be changed. This is more economical than a system where you need to throw out two or three filters when only one needs changing.

### The HEPA System's 3 Stage Filtration Process

The 3 stage filtration process is used to create a very effective filtration system. Each filter is independent and can be changed individually.

- Stage 1: Pre-filter - The inexpensive foam pre-filter removes larger particulates from the air, thus prolonging the life of the HEPA filter.
- Stage 2: HEPA - The HEPA filter removes 99.97% of particulates 0.3 micron and larger. The cleaned air then passes through the third stage filter.
- Stage 3: Carbon - The carbon filter is about 1/2 an inch thick to give it plenty of surface area for removing chemicals and odors from the air. The clean air is then reintroduced into the air you breathe.

## Parts Identification

### Cabinet Parts

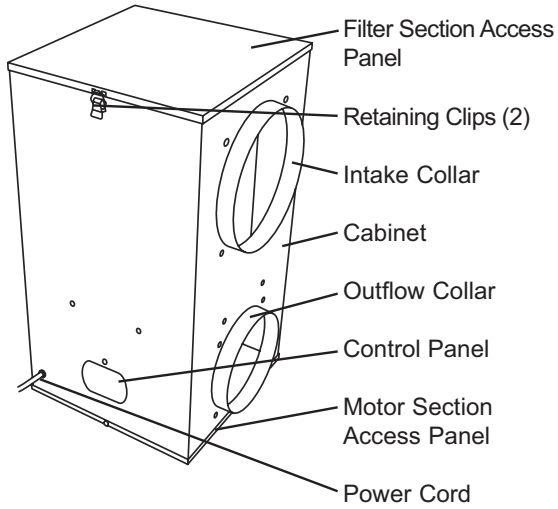

### Inside Cabinet (Filter Section)

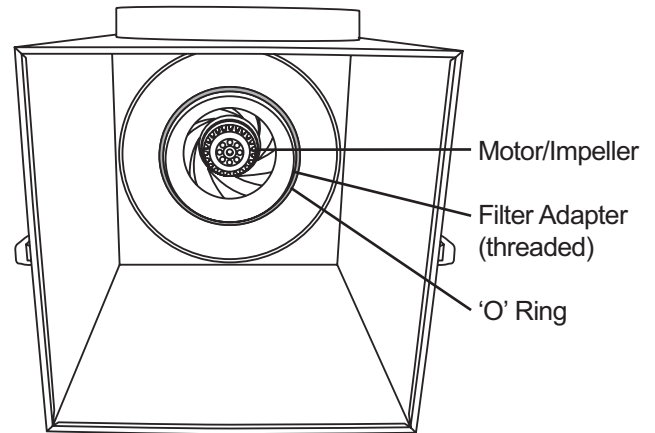

## Filter parts identification

### HEPA Cartridge Parts

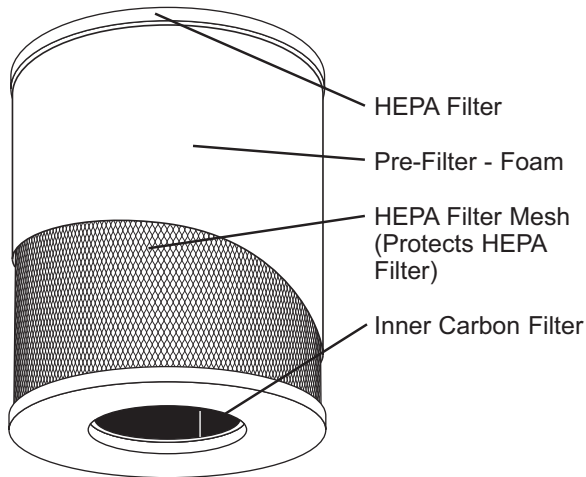

## Physical dimensions of unit

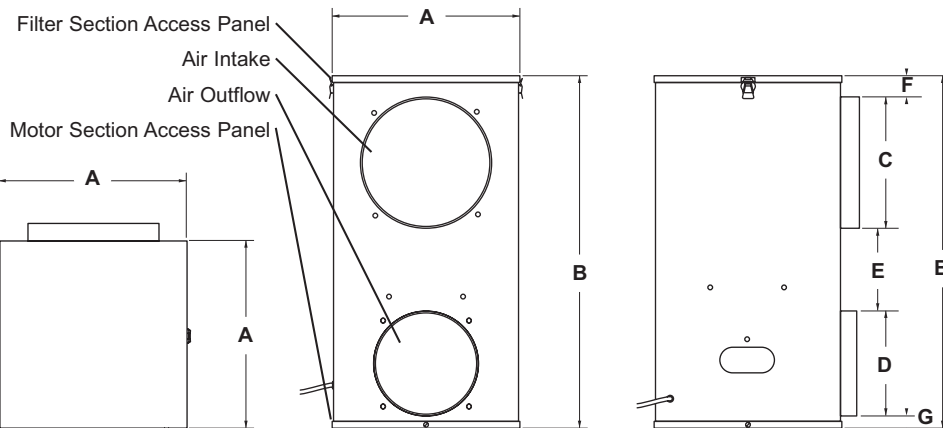

Model Unit	A	B	C	D	E	F	G
350	14.5 (36.8)	27.25 (692)	7.875 (200)	5.875 (149)	8.5 (216)	3 (76)	2 (51)
675	14.5 (368)	27.25 (692)	9.875 (251)	7.875 (200)	6.5 (165)	2 (51)	1 (32)

Dimensions in inches (mm)

## Dealer Installation Instructions

### Forced air handler/furnace systems:

The HEPA system should be installed as a bypass system, with part of the return ducted into the HEPA system. The filtered air is then rerouted back into the return air, and continues through the system to be heated/cooled.

### Typical Return to Return Application

For homes with upflow forced air handler/furnace systems. (Air handler/furnace is shown in a typical basement.)

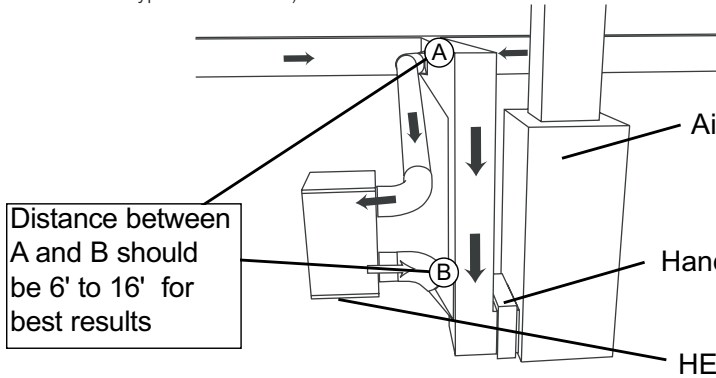

### Typical Return to Return Application

For homes with horizontal forced air handler/furnace systems. (Air handler/furnace is shown in an typical attic.)

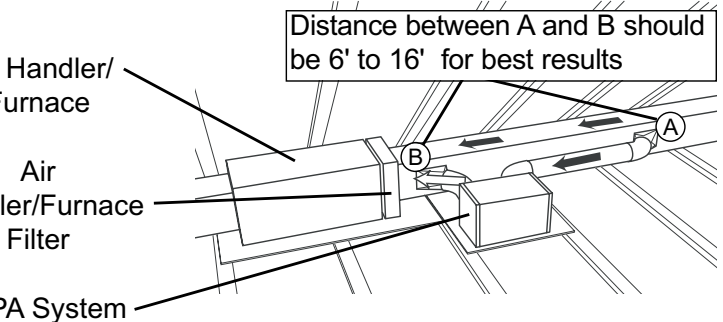

NOTE: This filtration system is an ADDITIONAL filter, and does NOT replace the existing air handler/furnace system filter.

### Preparation:

Here are some things to consider as you decide where to install the HEPA system.

### Location:

- Make sure there is room to open the HEPA filter access panel for filter changes/inspections.
- Keep the HEPA system in a location where you can still access the air handler/furnace filter.
- Keep the HEPA system away from possible water damage.
- Vibration pads will reduce vibration for installations where the unit is placed on the floor.
- Install HEPA System on floor or suspended platform. If the unit is suspended, screws must not penetrate through the cabinet. Make sure that you have the proper chains/straps/joists and equipment to keep unit secure. Intake (Marked as 'Air In' on unit):
- Intake ducts should be installed upstream of any humidifiers and be installed on the main return.
- Intake duct should be installed at least 6 ft. away from the outflow duct on the main return. Outflow (Marked as 'Clean Air Out' on unit):
- Outflow duct should be installed as close to the air handler/furnace inlet as possible but not directly into the return air elbow of the main return.
- If the unit is being installed independently of any other system, room diffusers are recommended to help distribute airflow evenly in the occupied space.

### Ducting:

- If HEPA system is installed where inlet and outflow collars face down, metal elbows must be connected to both inlet and outflow collars.
- Each connection must be sealed with aluminum tape or mastic, including all take offs.
- Installed duct runs should be as straight as possible (if the duct runs are too long, reduced CFM may result).
- If duct is exposed to unconditioned air, externally insulated flex duct is highly recommended.
- Externally insulated flex duct can also be used for noise reduction purposes.
- For best indoor air quality, do not use ductboard or fiberglass inside of ducts.

### Electricity:

- The unit must be plugged into a grounded 120V, 60Hz outlet.

### Required Materials for Installation of Unit:

Items for 350	
Flex or rigid duct (length as required)	8" round & 6" round
Takeoffs	One 8" & One 6"
Items for 675	
Flex or rigid duct (length as required)	10" round & 8" round
Takeoffs	One 10" & One 8"
All Models	
Aluminum tape or mastic as required	
Misc. hanging materials - field provided	

NOTE: Be sure to review 'Rules for Safe Installation and Operation' on page 1 of this document before start-up of this unit.

## Dealer Installation Instructions

### Forced air handler/furnace system with an HRV/ERV:

This application provides filtration of all Outdoor Air (OA) that is brought into the home through the HRV/ERV, thus reducing the introduction of dust, pollen and mold from the outdoor air. For systems that have HRV/ERV units installed, we recommend ducting the 'fresh air' outflow from the HRV/ERV into the HEPA system. If the HRV/ERV CFM (cubic feet per minute) rating is lower than that of the HEPA system, an additional return needs to be installed into the HEPA system. The outflow air from the HEPA system then needs to be installed into the main return of the air handler/furnace system. Ensure that you follow the proper installation instructions as outlined in the HRV/ERV Installation manual(s).

### Preparation:

Here are some things to consider as you decide where to install the HEPA system with an HRV/ERV.

### Location:

- Make sure there is room to open the HEPA filter access panel for filter changes/inspections.
- Keep the HEPA system in a location where you can still access the air handler/ furnace filter.
- Keep the HEPA system away from possible water damage
- Vibration pads will reduce vibration for installations where the unit is placed on the floor.
- Install HEPA System on floor or suspended platform. If the unit is suspended, screws must not penetrate through the cabinet. Make sure that you have the proper chains/straps/joists and equipment to keep unit secure.

### Intake (Marked as 'Air In' on unit):

- Most HRV/ERV systems will not move as much air as the HEPA system. For these systems, install an additional return from another treated air source into the HEPA system.
- If using an additional return duct, it should be installed upstream of any humidifiers. The fresh air outflow of the HRV/ERV should be "Y" connected to the additional return duct then connected to the inlet of the HEPA system.
- The additional return duct (if any) should be installed at least 6 ft. away from the outflow duct on the main return.
- Duct both the HRV/ERV and the additional return into the intake of the HEPA system.

### Outflow (Marked as 'Clean Air Out' on unit):

- Outflow duct should be installed as close to the air handler/furnace inlet as possible but not directly into the return air elbow of the main return.

### Ducting:

- If HEPA system is installed where inlet and outflow collars face down, metal elbows must be connected to both inlet and outflow collars.
- Each connection must be sealed with aluminum tape or mastic, including all take offs.

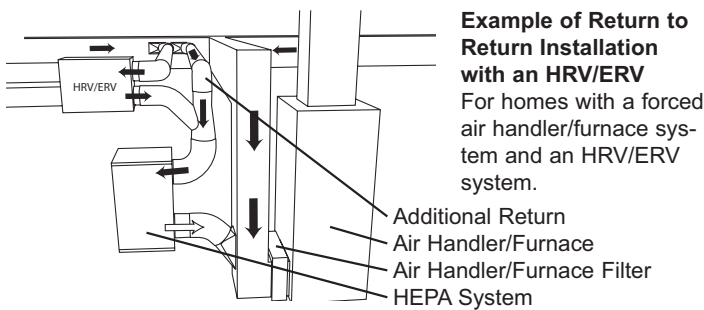

NOTE: This filtration system is an ADDITIONAL filter, and does NOT replace the existing air handler/furnace system filter.

Installed duct runs should be as straight as possible (if the duct runs are too long, reduced CFM may result).

- If duct is exposed to unconditioned air, externally insulated flex duct is highly recommended.
- Externally insulated flex duct can also be used for noise reduction purposes.
- For best indoor air quality, do not use ductboard or fiberglass inside of ducts.

### Electricity:

- The unit must be plugged into a grounded 120V, 60Hz outlet.

Required Materials for Installation of Unit:	
<b>Items for 350</b>	
Flex or rigid duct (length as required)	8" round & 6" round
Takeoffs	One 8" & One 6"
<b>Items for 675</b>	
Flex or rigid duct (length as required)	10" round & 8" round
Takeoffs	One 10" & One 8"
<b>All Models</b>	
Aluminum tape or mastic as required	
Misc. hanging materials - field provided	

NOTE: Be sure to review 'Rules for Safe Installation and Operation' on page 1 of this document before start-up of this unit.

## Dealer Installation Instructions

The HEPA systems can be used independently of any other equipment! The intake and outflow of the filtration system can be ducted into the same room to create a cleaner environment almost anywhere. The intake or outflow can also be ducted elsewhere. The intake and outflow should be installed on opposite sides of the room; however, this varies according to your specific needs.

### Preparation:

Here are some things to consider as you decide where to install the HEPA system independently of other systems.

### Location:

- Make sure there is room to open the HEPA filter access panel for filter changes/inspections.
- Keep the HEPA system away from possible water damage
- Vibration pads will reduce vibration for installations where the unit is placed on the floor.
- Install HEPA System on floor or suspended platform. If the unit is suspended, screws must not penetrate through the cabinet. Make sure that you have the proper chains/straps joists and equipment to keep unit secure.

### Intake (Marked as 'Air In' on unit):

- Intake ducts should be installed near the floor for optimum airflow. If space does not allow, then the inlet can be installed in the ceiling.
- Intake duct should be installed at least 6 ft. away from the outflow duct.
- Intake duct should be installed at opposite end of the room from the outflow duct(s) if in the same room.
- Diffusers are recommended to help distribute airflow evenly.

### Outflow (Marked as 'Clean Air Out' on unit):

- Outflow(s) should be installed in the ceiling away from any other air inlet(s)
- Room diffusers are recommended to help distribute airflow evenly in the occupied space.

### Ducting:

- If HEPA system is installed where inlet and outflow collars face down, metal elbows must be connected to both inlet and outflow collars.
- Each connection must be sealed with aluminum tape or mastic, including all vent connections.
- Installed duct runs should be as straight as possible (if the duct runs are too long, reduced CFM may result).
- If duct is exposed to unconditioned air, insulated flex duct is highly recommended.

### Example of Single Room Stand Alone System Installation

For single rooms where increased filtration is desired such as a dedicated 'smoking room'.

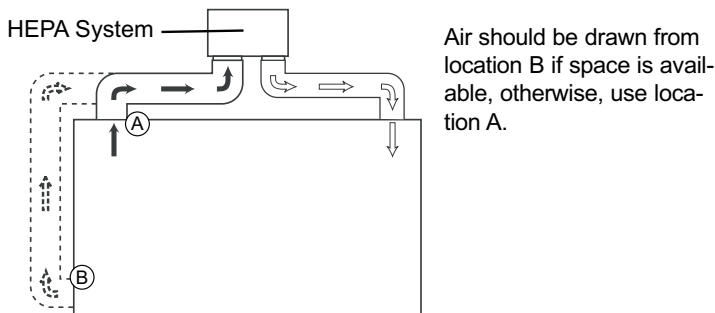

Externally insulated flex duct can also be used for noise reduction purposes.

- For best indoor air quality, do not use ductboard or fiberglass inside of ducts.

### Electricity:

- The unit must be plugged into a grounded 120V, 60Hz. outlet.

Required Materials for Installation of Unit:	
<b>Items for 350</b>	
Flex or rigid duct (length as required)	8" round & 6" round
Takeoffs	One 8" & One 6"
Diffusers	One 8" & One 6"
<b>Items for 675</b>	
Flex or rigid duct (length as required)	10" round & 8" round
Takeoffs	One 10" & One 8"
Diffusers	One 8" & One 6"
<b>All Models</b>	
Aluminum tape or mastic as required	
Misc. hanging materials - field provided	

NOTE: Be sure to review 'Rules for Safe Installation and Operation' on page 1 of this document before start-up of this unit.

## Operation (350 & 675)

- 1 Make sure that the unit is plugged into a grounded power source (120 Volt, 60 Hz).
- 2 For optimum performance, the HEPA system should operate with the indoor air handler/furnace blower on.
- 3 Turn the unit on by pressing the on/off button and the green power light will illuminate.
- 4 To turn the unit off, press the on/off button and the power indicator light will go out.

### Filter Light Indicators

Your HEPA system is equipped with an electronic filter timer. This timer monitors the life expectancy of each filter in the unit. By default, the Pre-Filter, HEPA Filter and VOC Blanket lights will turn on when the unit is powered on.

- 5 Turn the unit off and see instructions for "filter removal" to determine if filter replacement is needed. See "Maintenance" on next page.
- 6 Once the filters have been checked or replaced, turn the unit back on and reset the control panel. To reset, press and hold the flashing filter button until the light is constant.

## Maintenance

Proper care and maintenance of your HEPA system will ensure years of service. The unit must be turned off during service/maintenance or when filters are being changed. It is recommended that gloves and a filtered breathing mask be worn during filter replacement.

	<b>⚠ WARNING</b>
	<b>Electrical Shock Hazard.</b> Can cause injury or death. Disconnect all electrical power supplies before servicing. Do not operate equipment without access panels in place.

<b>⚠ CAUTION</b>
Risk of Sharp Edges Hazard. Equipment sharp edges can cause injuries. Avoid grasping equipment edges without protective gloves.

## Inner Carbon Filter:

The inner carbon filter will rarely look used. This filter captures odors and gasses, yet the filter's appearance will not change. When this filter has reached its maximum adsorbency of odors and gasses, it will no longer work. Replace this filter when it no longer seems to capture odors, or every 3 months, whichever occurs first.

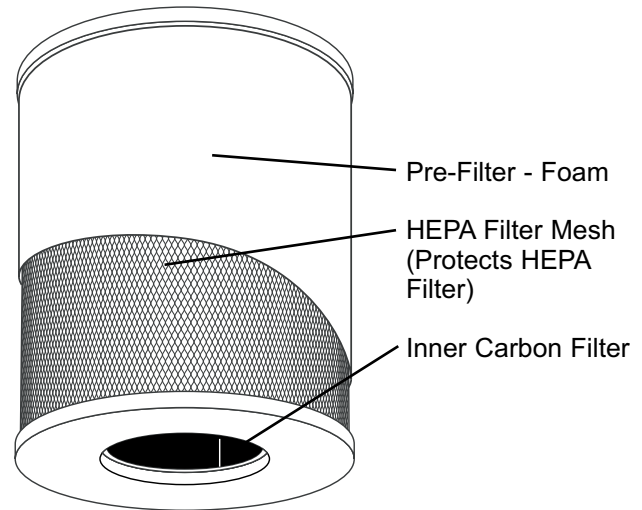

## Filter Change Schedule

Note: Note: Failure to properly maintain your HEPA system will decrease the efficiency and air flow.

**Foam Pre-Filter: 3 to 4 months\***

**HEPA Filter: 2 to 5 years**

**Inner Carbon Filter: 6 months**

\* The foam pre-filters can be washed and reused

NOTE: Filter life is based on average air content.

Some filters may need to be changed more often due to higher amounts of dust, humidity, or chemicals found in your ambient air. Additionally, people who are more sensitive to these airborne contaminants may desire more frequent filter changes.

## Filter Changing Guidelines

### Pre-Filter:

Dust and other large particles will collect on the pre-filter over time. The color of the filter will change as particulates build up on the pre-filter. Change the pre-filter when you can see the particulate build up start to clog up the pre-filter.

### HEPA Filter:

As the HEPA filter captures particulates, it will darken over time. Replace the HEPA filter when it darkens to the level seen in example D.

**A. New**      **B. Used**      **C. Used**      **D. Replace**



## Dealer Filter Change Instructions

	<b>⚠ WARNING</b>
	<b>Electrical Shock Hazard.</b>
	Can cause injury or death.
	Disconnect all electrical power supplies before servicing.

	<b>⚠ CAUTION</b>
	<b>Risk of Sharp Edges Hazard.</b>
	Equipment sharp edges can cause injuries.

	<b>⚠ CAUTION</b>
	<b>Risk of Sharp Edges Hazard.</b>
	Equipment sharp edges can cause injuries.

Avoid grasping equipment edges without protective gloves.

	<b>⚠ CAUTION</b>
	<b>Risk of Sharp Edges Hazard.</b>
	Equipment sharp edges can cause injuries.

Avoid grasping equipment edges without protective gloves.

It is recommended that gloves and a filtered breathing mask be worn during filter replacement to avoid breathing particulates (dust, mold, pollen, etc.) captured on the filter that become airborne during the filter(s) changeout. The old filters should be wrapped and sealed in plastic bags immediately upon removal from the unit to avoid distributing particles throughout the house during the process of disposal.

1. Accessing the filters
  - a. Remove safety screw(s) from HEPA filter access panel.
  - b. Unlatch the two retaining clips and lift off HEPA filter access panel.
  - c. Bracing the unit so it does not move, turn the HEPA cartridge counter clockwise and lift/pull out.
2. Pre-filter Replacement
  - a. Pull the pre-filter up and off the unit.  
NOTE: The pre-filter may contain contaminants, remove it slowly to avoid releasing particles back into the air.
  - b. Foam pre-filters can be washed several times, wash by hand in warm water. Let it dry completely before placing it back onto the HEPA cartridge.
  - c. If replacing the filter, remove plastic shrink wrap from the new pre-filter.
  - d. Stretch the new/washed filter around the top of the HEPA cartridge and slide it down into place
3. Inner Carbon Filter Replacement
  - a. Look inside the HEPA cartridge to locate the two ends of the inner carbon filter.
  - b. Pull one end of the old inner carbon filter in and bend it into a loose roll so it can be removed.
  - c. Remove the inner carbon filter from the HEPA cartridge.
  - d. Remove plastic shrink wrap from the new inner carbon filter.
  - e. Unroll the inner carbon filter and roll it up in the opposite direction (this makes the filter follow a more contoured profile against the inner HEPA filter surfaces and helps keep it in place), place the rolled inner carbon filter inside the HEPA cartridge and gently unroll it until the ends 'butt' together and the filter is snug against the HEPA filter.
4. HEPA Filter Replacement
  - a. If replacing the HEPA filter with a new filter, discard old HEPA filter and use new when replacing the HEPA filter into the unit.
  - b. With each annual filter replacement kit, a new 'o' ring is provided. The old one is removed by pinching it between two fingers and pulling it off the collar on the blower deck.
  - c. Discard old 'o' ring.
  - d. Place the new 'o' ring onto the collar and slide it down to the base of the blower deck.

5. Installing the HEPA Filter Cartridge
  - a. With the filters changed or inspected, all 3 filters are ready to be placed back into the unit. Place the HEPA cartridge gently into the unit
  - b. When the HEPA cartridge is in place, brace the unit, press down and gently turn it clockwise to lock it into place. If too much force is used, the cartridge may be difficult to remove!
  - c. Replace the HEPA filter access panel and latch it with the two retaining clips.
  - d. Re-install safety screw(s) into HEPA filter access panel.
  - e. Plug the unit back into a power outlet and turn it on.



## Dealer Motor Assembly Replacement Instructions



**⚠ WARNING**

**Electrical Shock Hazard.**

Can cause injury or death.

Disconnect all electrical power supplies before servicing.

Do not operate equipment without access panels in place.

**⚠ CAUTION**

**Risk of Sharp Edges Hazard.**

Equipment sharp edges can cause injuries.

Avoid grasping equipment edges without protective gloves.

1. Accessing the motor assembly
  - a. Turn the unit off and unplug it from any electrical source before opening the cabinet.
  - b. Remove the safety screw(s) from the motor section access panel.
  - c. Lift the door off the unit.
2. Removing the old motor assembly
  - a. Disconnect all four motor wires from switch, ground post and capacitor.
  - b. Disconnect the two white wires from the capacitor.
  - c. Separate the motor from the motor mount by removing the four screws found in figure 1.
  - d. Slide the motor out from under the motor mount to remove it from the unit.
3. Installing the new motor assembly
  - a. Slide the new motor into the motor mount making sure that the wires go through the smaller hole offset from the center of the bracket.
  - b. Secure the new motor to the motor mount with the four screws removed in step 2c.

- c. Connect the wires as follows:
  - Black wire from the Plug and Cable (P12) to Line (P3) on the CM71 Power Module
  - Green wire from CM71 Power Module to the ground post
  - Blue wire from motor to the Motor-2 (P4) post on the CM71 Power Module
  - Yellow/green wire from motor to the ground post
  - Brown wire from the motor to a Capacitor (C10) post
  - Black wire from the motor to the Motor-1 (P2) post on the CM71 Power Module
  - White wire from Neutral (P1) on the CM71 Power Module to the black wire on the motor via piggyback post to the empty Capacitor (C10) post.
4. Closing the unit
  - a. Replace the motor section access panel and secure it with the screws removed in step 1b.
  - b. Plug the unit into its electrical source and turn it on.

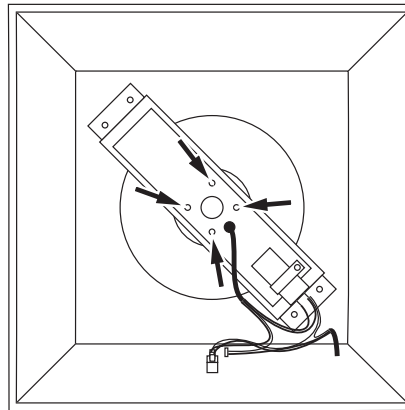

**Figure 1**

## Electrical diagram

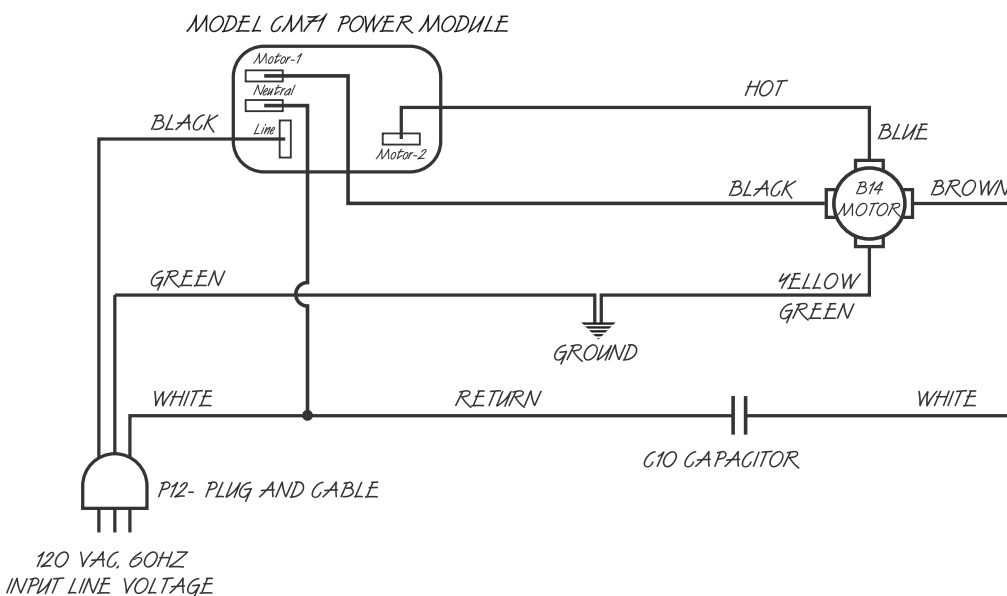

## Beam Central HEPA Air Filtration Systems Item List

Beam Model 350 Central Hepa Air Filtration System & Replacement Filters	
HEPA Cartridge Replacement 15"	Replacement HEPA for 350/675
Annual Filter Kit 15" Standard	1 Foam Prefilter, 2 Carbon Inner Blanket for 350/675
Replacement Components For Beam Model 350 Central Hepa Air Filtration Systems	
Filter Cabinet Lid	* refer to part inventory diagram for description
Cabinet 350	
Bulkhead 350	
Filter Cabinet Base	
Motor Bracket 350	
Motor for 350	
Intake Collar 350: 8"	
Exhaust Collar 350: 6"	
Electronic Key Pad	
Electronic Switch Board	
Capacitor 350	
O Ring	
Beam Model 675 Central HEPA Air Filtration System & Replacement Filters	
HEPA Cartridge Replacement 15"	Replacement HEPA for 350/675
Annual Filter Kit 15" Standard	1 Foam Prefilter, 2 Carbon Inner Blanket for 350/675
Replacement Components For Beam Model 675 Central HEPA Air Filtration Systems	
Filter Cabinet Lid	* refer to part inventory diagram for description
Cabinet 675	
Bulkhead 675	
Filter Cabinet Base	
Motor Bracket 675	
Motor for 675	
Intake Collar 675: 10"	
Exhaust Collar 675: 8"	
Electronic Key Pad	
Electronic Switch Board	
Capacitor 675	
O Ring	

If you have questions, contact your local Beam dealer.

Beam Central HEPA Air Filtration Systems (models 350/675)  
 PART INVENTORY with item numbers

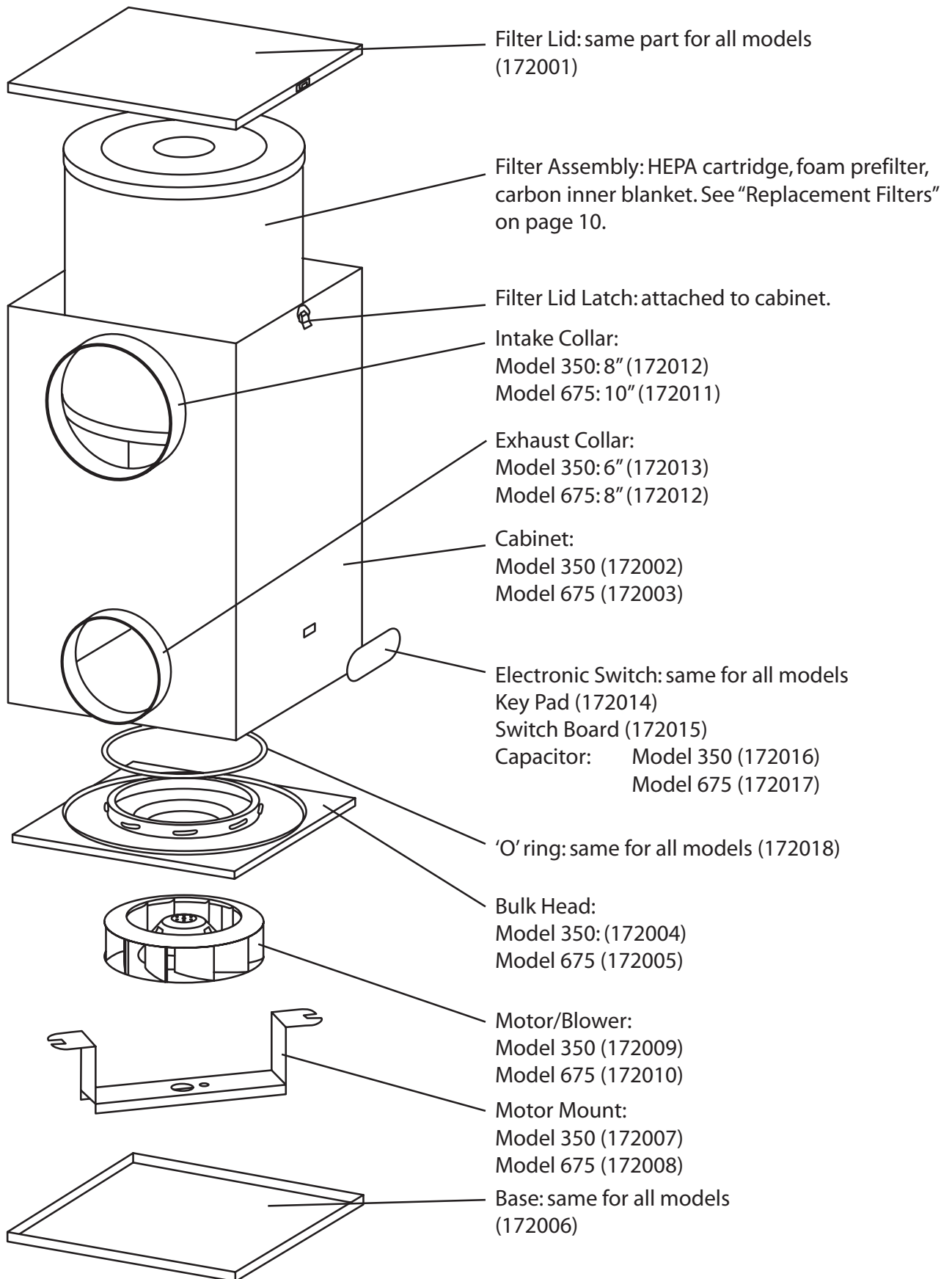



Electrolux Central Vacuum Systems

1700 W. Second

Webster City, IA USA 50595

visit our website at [www.beam.com](http://www.beam.com)