

FAVORIT 40650

Dishwasher

User information



Dear Customer,

Please read this user information carefully and keep it to refer to later. Please pass the user information on to any future owner of the appliance.

The following symbols are used in the text:



Safety instructions

Warning! Information that affects your personal safety.

Important! Information that prevents damage to the appliance.



Useful tips and hints



Environmental information



Your dishwasher is fitted with the new "PULSE WASH" dishwashing system. With this dishwashing system the motor speed and spray pressure are varied during the dishwashing cycle to achieve better cleaning of the dishes. It is for this reason that the noise level varies during the dishwashing cycle.

Contents

Operating Instructions	4
Safety	4
Diagram of Appliance	5
Control Panel	5
Prior to Using for the First Time	7
Setting the Water Softener.....	7
Adding dishwasher Salt.....	9
Filling Up with Rinse Aid.....	10
In daily use	13
Loading cutlery and dishes.....	13
Adding Detergent.....	17
Using 3in1 detergents.....	18
Selecting the dishwashing cycle (Cycle Table).....	19
Starting a Dishwashing Cycle.....	20
Setting the Delay Timer.....	20
Switching Off the dishwasher.....	21
Care and cleaning	22
What to do if	23
Remedying small malfunctions.....	23
If the Dishwashing Results are not Satisfactory.....	24
Disposal	25
Technical Data	26
Notes for Test Institutes	27
Installation and connection instructions	29
Safety Information for the Installation	29
Installing the Dishwasher	30
Connecting the dishwasher	32
Electrical Connection.....	35
Warranty conditions	37
Service and Spare Parts	39

Operating Instructions



Safety

Prior to using for the first time

- Follow the "Instructions for installation and connection".

Correct Use

- The dishwasher is only intended for washing domestic dishes.
- Additions or modifications to the dishwasher are not permitted.
- Use only special salt, detergent and rinse aid suitable for domestic dishwashers.
- Do not put any solvents in the dishwasher. This could cause an explosion.

Child Safety

- Keep packaging away from children. There is a risk of suffocation.
- Children often do not recognise the hazards associated with electrical appliances. Don't allow children to use the dishwasher unsupervised.
- Make sure that children and pets don't climb into the dishwasher. Could endanger life!
- Dishwasher detergents can cause chemical burns to the eyes, mouth and throat. Could endanger life! Comply with the safety instructions of the dishwasher detergent manufacturer.
- The water in the dishwasher is not for drinking. Risk of chemical burns.

General Safety

- Repairs to the dishwasher are only to be carried out by qualified/authorised service engineers.
- When the dishwasher is not being used, switch it off and shut off the water tap.
- Never unplug the appliance by pulling on the cable. Always pull the plug.
- Never sit or stand on the open door.
- If the dishwasher is located in a room where there may be a frost, remove the connection hose from the tap after each use of the dishwasher.

Diagram of Appliance

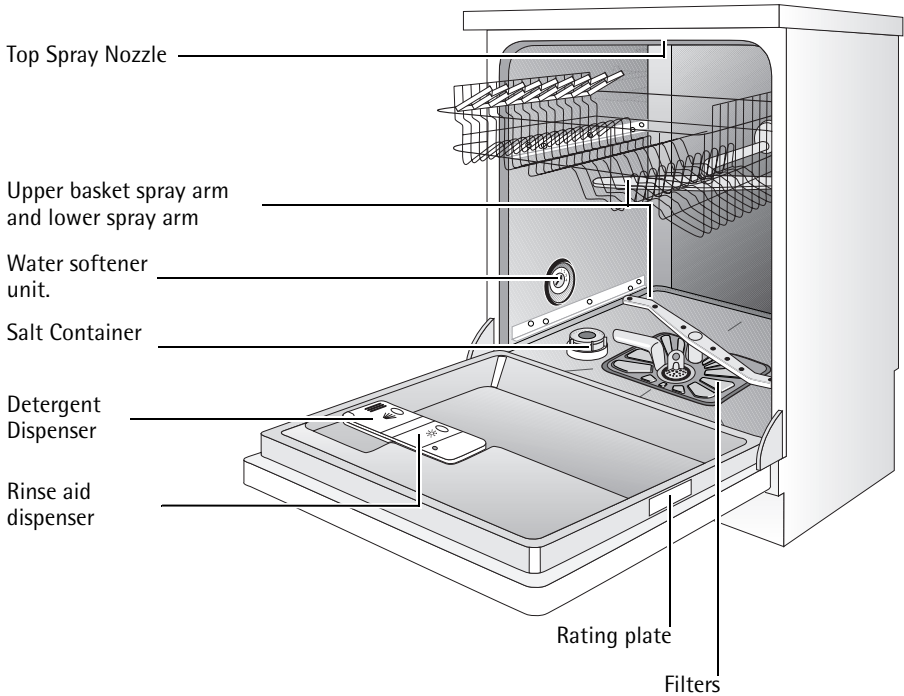

Control Panel

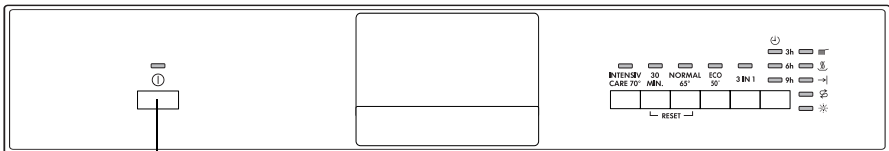

ON/OFF button

The **ON/OFF button** is used to turn the dishwasher on and off.

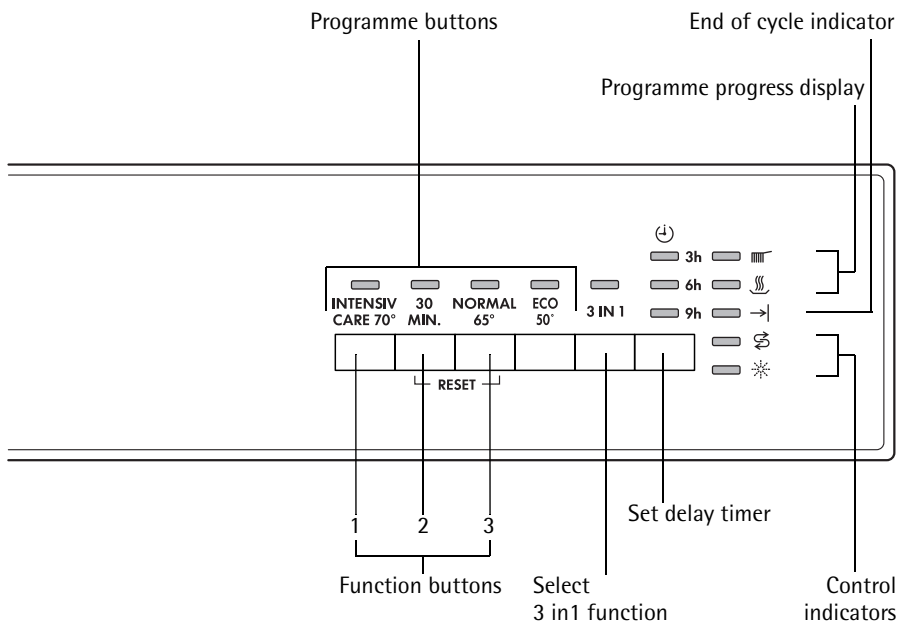

The **Programme buttons** are used to select the desired dishwashing cycle.

Function buttons: In addition to the pre-set dishwashing cycle, the following functions can also be set using these buttons:

Function button 1	Set the water softener
Function button 2	Activate/deactivate rinse aid dispenser
Function button 3	- not programmed -

Programme progress display: The current stage of the programme is always shown in the programme progress display.

The **control indicators** have the following meanings:

⊗ ¹⁾	Refill with dishwasher salt
* ¹⁾	Refill with rinse aid

1) These control indicators are never illuminated while a dishwashing cycle is running.

Prior to Using for the First Time

1. Set the water softener
2. Fill up with dishwasher salt
3. Fill up with rinse aid



- If you wish to use 3in1 detergent, do the following:
- First read the section "Using 3in1 detergents".
 - Switch on the dishwasher, press 3in1 button. The button indicator lights up: 3in1 function is selected. As a result
 - there is no need to fill up with dishwasher salt or rinse aid.
 - there is no need to set the water softener.
 - there is no need to activate/deactivate the rinse aid dispenser.
 - Before the start of the dishwashing cycle put 3in1 detergent in the detergent dispenser.

Setting the Water Softener

The water softener must be set manually and electronically:



To avoid scale deposits on the dishes and in the dishwasher, the dishes must be washed with soft water, i.e. water with a low lime content. The water softener must be set according to the table to the water hardness in the area where you live. Your local water company will be able to give you information about the water hardness in your area.

The dishwasher must be switched off.

Setting manually:

1. Open the dishwasher door.
2. Remove the lower basket from the dishwasher.
3. Turn water hardness dial on the left wall of the dishwasher interior to 0 or 1 (see table).

Setting electronically:

1. Press the ON/OFF button.



If indicators for the programme buttons are lit, a dishwashing cycle is activated. The cycle must be deactivated: Press function buttons **2** and **3** simultaneously for approx. 2 seconds. All additional wash programme button indicators will go out.

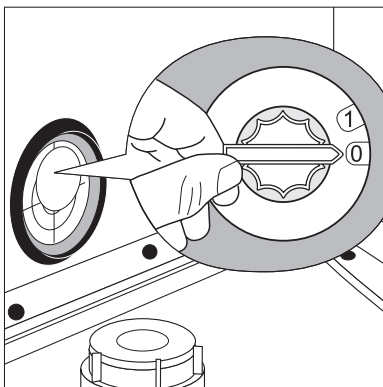

2. Press function buttons **2** and **3** simultaneously and keep them pressed.
The LED indicators for function buttons 1 to 3 will flash.
3. Press function button **1**.
The LED indicator for function button **1** will flash.
The LED indicator for the end of the dishwashing cycle will flash simultaneously:
 - The number of times that the LED indicator for the end of the dishwashing cycle flashes corresponds to the hardness setting.
 - This sequence of flashes is repeated several times, with a 3 second pause in-between.
4. Pressing function button **1** increases the hardness setting by 1 degree.
(Exception: hardness setting 1 follows hardness setting 10).
5. When the hardness setting is correct, press the ON/OFF button.
The hardness setting is now saved.
If the water softener is set electronically to "1", this switches off the control indicator for special salt.

Water hardness			Adjusting the hardness setting		Number of flashes
in °d ¹⁾)	in mmol/l ²⁾)	Range	Manual	Electronic	
51 - 70	9,0 - 12,5	IV	1	10 ³⁾	10
43 - 50	7,6 - 8,9			9	9
37 - 42	6,5 - 7,5			8	8
29 - 36	5,1 - 6,4			7	7
23 - 28	4,0 - 5,0			6	6
19 - 22	3,3 - 3,9	III	0*	5	5
15 - 18	2,6 - 3,2			4*	4
11 - 14	1,9 - 2,5	II		3	3
4 - 10	0,7 - 1,8	I/II		2	2
below 4	below 0.7	I		1 no salt necessary	1

1) (°d) German degree, measure of the hardness of water

2) [mmol/l] millimol per litre, international unit for water hardness

3) On this setting the length of the dishwashing cycle may be slightly longer.

*) factory setting

Adding dishwasher Salt

To decalcify the water softener, it must be filled up with dishwasher salt. Use only special salt suitable for domestic dishwashers.

If you do not use 3 in 1 detergent, fill up with dishwasher salt:

- Before using the dishwasher for the first time.
- When the control indicator for dishwasher salt is illuminated on the control panel.

1. Open the door and remove the lower basket.
2. Unscrew the lid on the salt dispenser by turning it anti-clockwise.

3. Only when using the dishwasher for the first time:

Fill the salt dispenser with water.

4. Place the funnel (supplied) over the dispenser opening. Fill the dispenser with dishwasher salt; the capacity of the dispenser is approx. 1.0–1.5 kg, depending on the size of the grains. Do not overfill the dispenser.

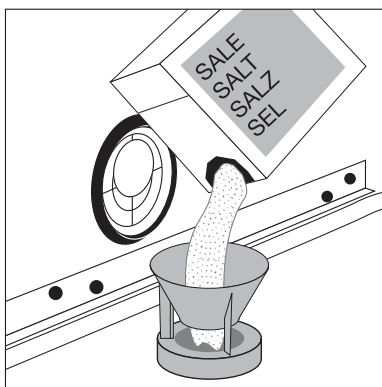

i If water overflows when filling up with dishwasher salt, this is completely harmless.

5. Clean away any salt remnants from the dispenser opening.
6. Screw the lid back on in a clockwise direction.
7. **Run a dishwashing cycle after filling the salt dispenser with dishwasher salt.** This will wash away salt water and salt crystals that have been spilt.

i Depending on the size of the salt granules, it can take several hours for the salt to dissolve in the water and for the control indicator for dishwasher salt to go out.

Filling Up with Rinse Aid

Rinse aid causes the rinse water to flow easily from the crockery leaving gleaming dishes and glassware.

If you do not use 3in1 detergent, fill up with rinse aid:

- Before using the dishwasher for the first time.
- When the control indicator for rinse aid is illuminated on the control panel.

Use only special rinse aid for dishwashers.

1. Open the door.
The rinse aid compartment is located on the inside of the dishwasher door.
2. Press the release button on the rinse aid compartment.
3. Open the cover.
4. Pour rinse aid in slowly right up to the broken "max" line; this corresponds to a volume of approx. 140 ml when full.
5. Press the lid shut until it clicks into place.
6. Wipe up any spilt rinse aid with a cloth. Otherwise there will be too much foam when rinsing.

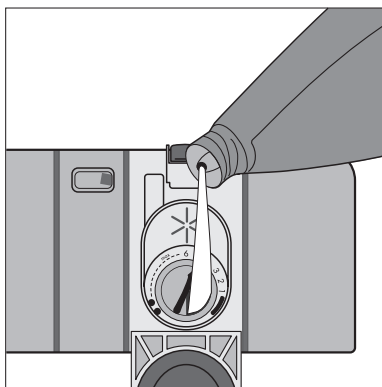
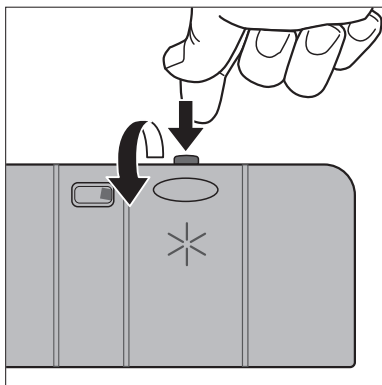

Setting the Amount of Rinse Aid Required



Only change the amount dispensed, if smears, milky spots (reduce the amount) or dried on water spots (increase the amount) can be seen on glasses and dishes. (See section "If dishwashing results are not satisfactory.") The dosage can be set from 1-6. The dosage is pre-set to "4" in the factory.

1. Open the dishwasher door.
2. Press the release button on the rinse aid compartment.
3. Open the cover.
4. Set the dosage level.
5. Press the lid shut until it clicks into place.
6. If rinse aid has leaked out, wipe it away with a cloth.

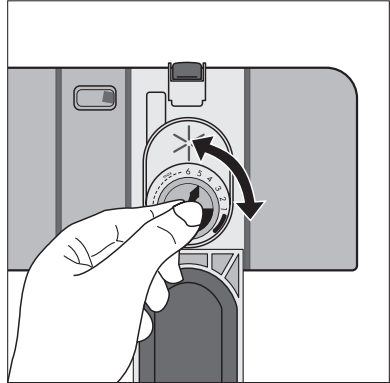

Activating/Deactivating the Rinse Aid dispenser

1. Press the ON/OFF button.



If indicators for the programme buttons are lit, a dishwashing cycle is activated. The cycle must be deactivated:

Press function buttons **2** and **3** simultaneously for approx. 2 seconds.

All additional wash programme button indicators will go out.

2. Press function buttons **2** and **3** simultaneously and keep them pressed. The LED indicators for function buttons 1 to 3 will flash.

3. Press function button **2**.

The LED indicator for function button **2** will flash.

The indicator for the end of the dishwashing cycle will display the current setting:

Indicator for the end of the cycle is lit:	Rinse aid dispenser activated (factory setting)
Indicator for the end of the cycle is not lit:	Rinse aid dispenser deactivated

4. Pressing function button **2** activates and deactivates the rinse aid dispensing function.

5. When the rinse aid dispenser setting is correct, press the ON/OFF button.

The setting for the rinse aid dispenser is now saved.

In daily use

Loading cutlery and dishes



Sponges, cleaning cloths and any other objects that can absorb water must not be washed in the dishwasher. Plastic and Teflon-coated dishes and pans tend to retain water droplets. These dishes and pans therefore do not dry as well as those made of china and stainless steel.

For washing in the dishwasher, the following cutlery/dishes/pots and pans	
are not suitable:	are of limited suitability:
<ul style="list-style-type: none">• Cutlery with wooden, horn, china or mother of pearl handles• Plastic items that are not heat resistant• Older cutlery with cement that is sensitive to temperature• Dishes or cutlery with glued parts• Pewter or copper items• Lead crystal glass• Steel items that rust• Wooden boards/platters• Items made from synthetic materials	<ul style="list-style-type: none">• Only wash stoneware in the dishwasher if it is specifically marked by the manufacturer as being dishwasher-safe.• Glazed patterns may fade if washed very frequently in the dishwasher.• Silver and aluminium parts have a tendency to discolour during washing. Food remains, e.g. egg white, egg yolk and mustard often cause discoloration and staining on silver. Therefore always clean food residues from silver immediately, if it is not to be washed straight after use.• Glass can become dull after a large number of washes.

- Before loading the dishes, you should:
 - Remove the worst of the food residues.
 - Soak pans with burnt-on food residues.
- When loading the dishes and cutlery, please note:
 - Dishes and cutlery must not impede the rotation of the spray arms.
 - Load bowls, cups, glasses, pans, etc. with the opening downwards so that water cannot collect in them
 - Dishes and items of cutlery must not lie inside one another or cover one another
 - To avoid damage to glasses, they must not touch one another
 - Don't put small items (e.g. lids) in the baskets for the dishes, but in the cutlery basket, so that they can't fall through the holes.

Loading cutlery



Warning: Sharp knives and other items of cutlery with sharp edges must be laid in the cutlery rack or in the upper basket to avoid the risk of injury.

To ensure that all items of cutlery in the cutlery basket can be reached by the water, you should:

1. Place the grid insert on the cutlery basket
2. Place forks and spoons in the cutlery basket's grid insert with their handles pointing downwards.

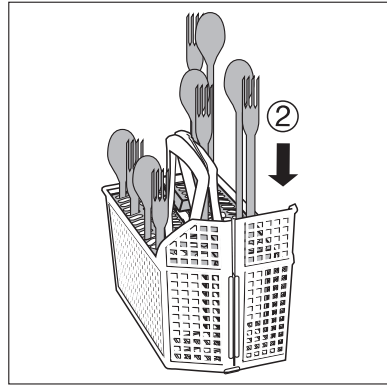
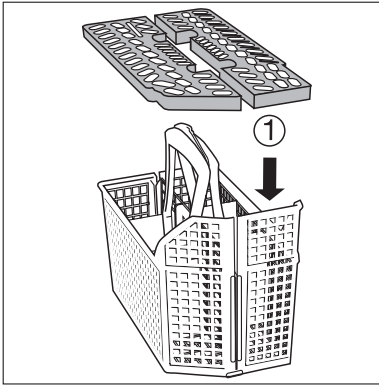

For larger utensils, such as whisks, leave off one half of the cutlery grid.

Pots, Pans, Large Plates

Load larger and heavily soiled dishes and pans in the lower basket. (Max. diameter for plates 29 cm).

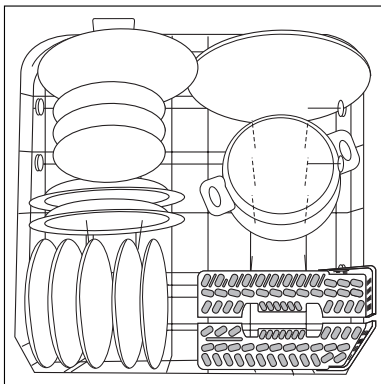

To make it easier to load larger dishes, the two plate racks on the right in the lower basket can be folded down.

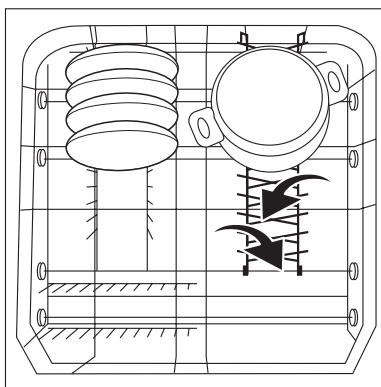

Cups, Glasses, Coffee Service

Load smaller, fragile crockery and long, sharp cutlery in the upper basket.

- Arrange items of crockery on and under the folding cup racks so that they are offset from each other and water can reach all items.
- The cup racks can be folded up out of the way for tall crockery items.
- Lay or hang wine and brandy glasses in the slots in the cup racks.

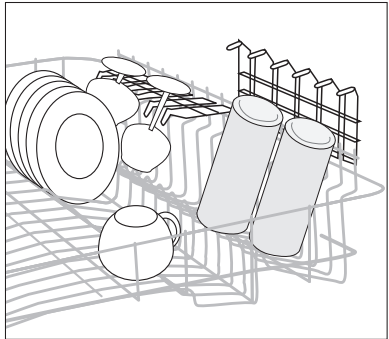
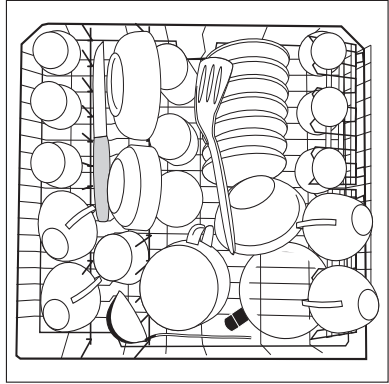

Adding Detergent

Detergents remove the dirt from dishes and cutlery. The detergent must be added before the cycle starts.



Only use detergent intended for domestic dishwashers.

The detergent compartment is located on the inside of the door.

1. If the lid is closed:
Press the release button.
The lid will spring open.

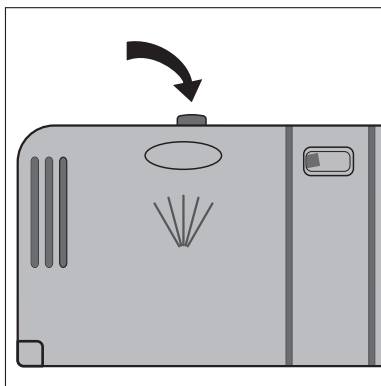

2. Place the detergent in the detergent dispenser. The markings indicate the dosing levels for powder detergents: "20/30" corresponds to approx. 20/30 ml of detergent. Follow the manufacturer's instructions with regard to dosing and storage.
3. Close the lid and press until it locks into place.

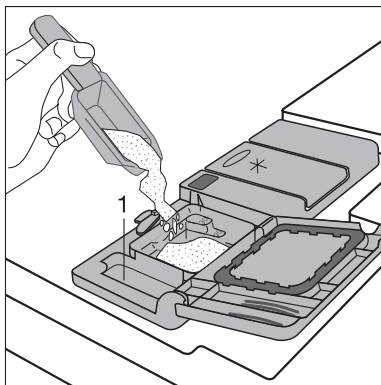

In the case of very heavily soiled dishes, fill the adjoining compartment (1) with additional detergent. This detergent comes into use during the pre-wash cycle.

Concentrated detergents

Today's detergents for dishwashers are almost exclusively low-alkaline concentrated detergents with natural enzymes in tablet or powder form.



Using 50°C dishwashing cycles in conjunction with these concentrated detergents reduces pollution and is good for your dishes, as these dishwashing cycles are specially matched to the dirt-dissolving properties of the enzymes in concentrated detergents. It is for this reason that using 50 °C dishwashing cycles in conjunction with concentrated detergents can achieve the same cleaning results that can otherwise only be achieved using 65 °C cycles.

Detergent tablets



Detergent tablets from different manufacturers dissolve at different rates. For this reason, some detergent tablets do not attain their full cleaning power during short cycles. Therefore please use dishwashing cycles with pre-wash when using detergent tablets.

Using 3in1 detergents

These products are detergents with a combined cleaning, rinsing and salt function.

1. Check whether these detergents are suitable for your water hardness. Follow the manufacturer's instructions.
2. Place detergent just in the detergent dispenser.

If you want to stop using 3in1 products, please do the following:

- Fill up the dispensers for salt and rinse aid again.
- Switch the water softener to the highest setting and perform up to three normal cycles without loading any dishes.
- Then set the water softener to the water hardness in your area.

Selecting the dishwashing cycle (Cycle Table)

Dishwashing cycle	Suitable for:	Type of soiling	Programme sequence					Consumption values ¹⁾		
			Pre-wash	Main wash	Intermediate rinse	Final rinse	Drying	Length (minutes)	Energy (kWh)	Water (litres)
INTENSIV CARE 70°²⁾	Dinner service and cookware	heavily soiled, dried-on food remains, in particular protein and starch	•	•	2x	•	•	120 - 130	1,80 - 2,00	22 - 24
30 MIN. (60°)³⁾	Dishes, excluding saucepans	just used, lightly to normally soiled	-	•	-	•	-	30	0,8	9
NORMAL 65°	Dinner service and cookware	normally soiled dried-on food remains	•	•	•	•	•	90 - 100	1,20 - 1,40	17 - 19
ECO 50°⁴⁾	Dinner service and cookware, temperature-sensitive dishes	normally soiled	•	•	•	•	•	130 - 160	0,95 - 1,05	14 - 16

1) The consumption values were obtained under standardised conditions. They depend on how full the baskets for the dishes are. Variations are therefore possible in practice.

2) During the final rinse, the temperature is increased to 68° for 10 minutes to disinfect e.g. babies' bottles.

3) When using this cycle, only load the dishwasher half full.

4) Test programme for Test Institutes.

Starting a Dishwashing Cycle

1. Check that the spray arms can turn freely.
2. Turn the water tap on fully.
3. Close the door.
4. Press the ON/OFF button.
5. Select the desired cycle.

The programme display lights up. One or two lights will flash in the programme progress display.

The selected cycle will begin after approximately 3 seconds.

Interrupting or Cancelling a dishwashing cycle

Interrupt a dishwashing cycle that is in progress if it is absolutely necessary.

Interrupting the dishwashing programme by opening the dishwasher door



Hot steam may escape when the door is opened. There is a risk of scalding.

1. Open the door carefully. The dishwashing cycle will stop.
2. Close the door. The cycle will continue.

Cancelling the dishwashing cycle

1. Press function buttons **2** and **3** and keep them pressed.
The programme display for the current cycle will flash for several seconds and then go out.
2. Release the function buttons. The dishwashing cycle has been cancelled.
3. If you want to start a new cycle, check whether there is any detergent in the dispenser.



Turning off the dishwasher will only interrupt a selected dishwashing cycle, not cancel it. The cycle will recommence after turning the dishwasher back on again.

Setting the Delay Timer

Using the delay timer you can delay the start of a dishwashing cycle for 3, 6 or 9 hours.

1. Press the ON/OFF button.

2. Press the Delay Timer button repeatedly until the indicator next to the number of hours for which the start of the dishwashing cycle is to be delayed lights up, e. g. 6h, if the cycle is to start in 6 hours.

3. Select dishwashing cycle.

The LED indicator for the programme selected and the indicator next to the number of hours will light up.

The dishwashing cycle will start automatically following a countdown of the hours set.

To change the time delay:

As long as the cycle has not yet started, you can still change the setting by pressing the DELAY TIMER button.

Cancelling the delay timer:

Press the DELAY TIMER button repeatedly until none of the three time displays is lit. The selected dishwashing cycle will begin immediately.

To change a dishwashing cycle

As long as the cycle has not yet started, you can still change the dishwashing cycle. First cancel the dishwashing cycle, then re-set the time delay, lastly select the new dishwashing cycle.

Switching Off the dishwasher

Do not switch off the dishwasher until the indicator for the end of the dishwasher cycle is illuminated in the cycle progress display.

1. Press the ON/OFF button. All display indicators will go out.
2. Turn off the water tap.



Carefully open the door. Hot steam may escape.

Hot dishes are sensitive to knocks. Therefore leave the dishes to cool for about 15 minutes before removing them. You also get a better drying result.

Removing the Dishes



It is normal for the inner door and the dispensers to be damp.

- Empty the lower basket first, then the upper basket. This way you avoid dripping water from the upper basket onto dishes in the lower basket.

Care and cleaning



Do not use furniture care products or aggressive cleaners.

- When necessary, clean the dishwasher's controls with a soft cloth.
- Occasionally check the internal dispensers, door seal and water inlet filter (if fitted) for dirt and clean them, if necessary.

Cleaning the Filters



The filters must be regularly checked and cleaned. Dirty filters will spoil the wash results.

1. Open the door and remove the lower basket.
2. Turn the handle about $\frac{1}{4}$ of a turn anticlockwise (A) and remove the filter system (B).

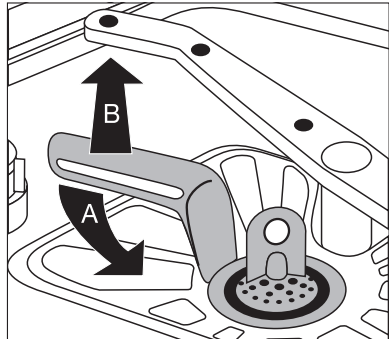

3. Take hold of the coarse and fine filters (1/2) by the handle and remove them from the micro-filter (3).
4. Clean all filters thoroughly under running water.
5. Remove the flat filter (4) from the base of the washing compartment and clean both surfaces thoroughly.
6. Re-insert the flat filter.

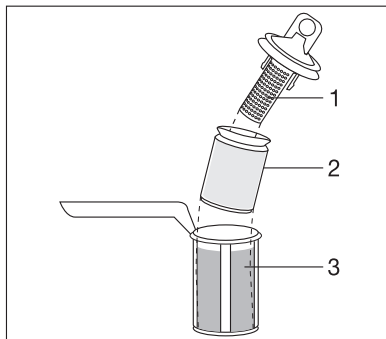

7. Place the coarse and fine filters in the micro-filter and press together.
8. Insert the filter system in place and lock it by turning the handle clockwise as far as it will go. Ensure that the flat filter does not protrude above the base of the washing compartment.

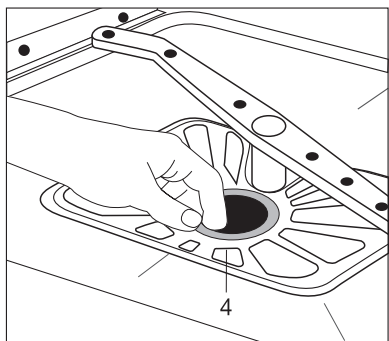

Under no circumstances may the dishwasher be used without its filters.

What to do if...

Remedying small malfunctions

If while the appliance is operating indicators on the control panel flash or are lit up as described in the following table, please consult this to find out how to remedy the fault.

After remedying the fault that is flashing in the **first or second rhythm** in the programme progress display, press the button for the dishwashing cycle that had already started. The cycle will continue. If the fault is displayed again or if other faults are displayed, please contact your local Service Force Centre and inform them of the fault display.

Malfunction	Possible cause	Remedy
The programme indicator for the selected dishwashing cycle is flashing, the indicator for the end of the dishwashing cycle is flashing in sequence 1 short light signal with approx. 3 second pause in-between: (Problems with water inlet)	The tap is blocked or furred with lime-scale.	Clean tap.
	The tap is turned off.	Turn the tap on.
	The filter (where present) in the threaded hose fitting on the tap is blocked.	Clean the filter in the threaded hose fitting.
	Filters in the base of the washing compartment are blocked.	Press the button for the dishwashing cycle that has started; then cancel the dishwashing cycle (see section: Starting a dishwashing cycle); clean filters (see section: Cleaning the filters).
	Water inflow hose has not been correctly positioned.	Check hose installation.
The programme indicator for the selected dishwashing cycle is flashing, the indicator for the end of the dishwashing cycle is flashing in sequence 2 short light signals one after another.	The sink spigot connection is blocked.	Clean the sink spigot outlet.
	Water drain hose has not been correctly positioned.	Check hose installation.

Malfunction	Possible cause	Remedy
the indicator for the end of the dishwashing cycle is flashing in sequence 3 short light signals one after another.	The anti-flood system has been triggered.	Turn off the tap and contact the Service Force Centre.
The cycle is not starting.	The mains plug is not plugged in.	Plug in mains plug.
	A fuse in the house's wiring system is defective.	Replace fuse.
	For dishwasher models with a delay start timer: A start time has been selected.	If the dishes are to be washed immediately, cancel the delay start.
Rust spots are visible in the dishwashing compartment.	The dishwashing compartment is made from rust-free stainless steel. Rust spots in the dishwashing compartment are due to rust particles from external sources (rust particles from water pipes, pans, cutlery, etc.). Remove such spots with a commercially-available stainless steel cleaning product.	Only wash cutlery, dishes and pans that are suitable for dishwasher use.
A whistling noise can be heard when washing dishes.	The whistling is not a cause for concern.	Use a different brand of detergent.

If the Dishwashing Results are not Satisfactory

The dishes are still dirty.

- The wrong dishwashing cycle was selected.
- The dishes were loaded in such a way that the dishwashing water did not reach all items. The baskets for the dishes must not be overloaded.
- The filters in the base of the washing compartment are dirty or incorrectly positioned.
- Good quality detergent was not used, or too little was used.
- In the case of scale deposits on the dishes: The dishwasher salt dispenser is empty or the water softening system has been incorrectly set.
- The drain hose is incorrectly positioned.

The dishes do not dry and are not shining.

- Poor quality rinse aid was used.
- The rinse aid dispenser is empty.

There are smears, streaks, milky spots or a shiny bluish coating on glasses and dishes.

- Lower rinse aid dosage.

There are dried water drops on the glasses and dishes.

- Increase rinse aid dosage.
- The detergent may be the cause. Contact the detergent manufacturer's customer advice centre.

Glass corrosion

- Contact the detergent manufacturer's customer advice centre.

Disposal



Packaging material

The packaging materials are environmentally friendly and can be recycled. The plastic components are identified by markings, e.g. >PE<, >PS<, etc. Please dispose of the packaging materials in the appropriate container at your local waste disposal facilities.



Old appliance

Please dispose of your old appliance in line with the guidelines for disposal in your area.



Warning! When your appliance has finished its working life, remove the plug from the socket. Cut off the cable and plug and dispose of them.

Break the door lock so that the door no longer shuts. This prevents children from trapping themselves inside and endangering their lives.

Technical Data

Capacity:	12 place settings including serving dishes
Permitted water pressure:	1-10 bar (=10-100 N/cm ² = 0.1-1.0 MPa)
Electrical connection:	Information on the electrical connection is given on the rating plate located on the right inner edge of the dishwasher door.
Dishwasher: Free-standing appliances	
Dimensions:	850 x 598 x 598 (H x W x D in mm)
Max. weight:	54 kg



This appliance conforms with the following EU Directives:

- 73/23/EEC dated 19.02.1973 Low Voltage Directive
- 89/336/EEC dated 03.05.1989 EMC Directive inclusive of Amending Directive 92/31/EEC
- 93/68/EEC dated 22.07.1993 CE Marking Directive

Notes for Test Institutes

Testing in accordance with EN 60704 must be carried out with the appliance fully loaded and using the test cycle (see "Cycle Table").

Tests in accordance with EN 50242 must be carried out when the salt dispenser in the water softener and the rinse aid dispenser have been filled with salt and rinse aid respectively, and using the test cycle (see "Cycle Table").

	Full load: 12 place settings including serving dishes	Half load: 6 place settings including serving dishes, leaving alter- nate positions in the rack free
Amount of detergent required:	5g + 25g (Type B)	20g (Type B)
Rinse aid setting:	4 (Type III)	4 (Type III)

Sample loading arrangements:

Upper basket^{*)}

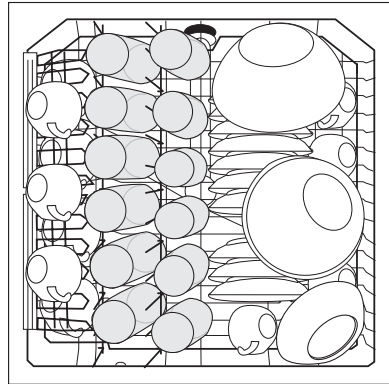
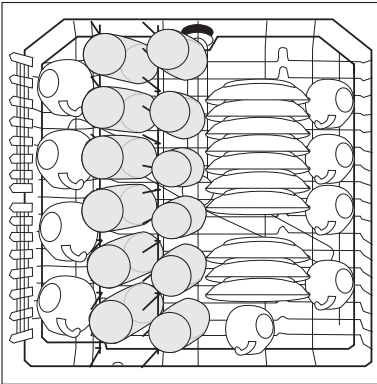

^{*)} If necessary, move the cup rack from right to left. When doing this, ensure that the cup rack is at the same height.

Lower basket with cutlery basket

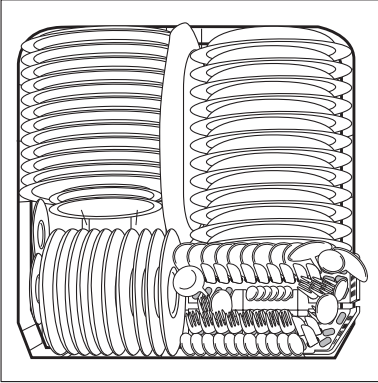

Cutlery basket

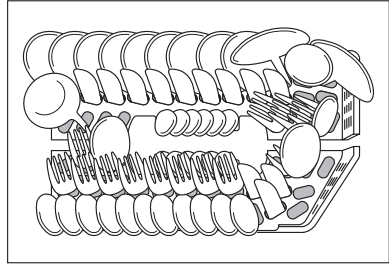

Installation and connection instructions



Safety Information for the Installation

- Only transport the dishwasher in an upright position, otherwise salt water may run out.
- Before using the dishwasher for the first time, check for any damage caused in transport. Do not under any circumstances connect an appliance that is damaged. In the case of damage, please contact your supplier.
- Never use the dishwasher if the mains cable, water inlet or drain hose are damaged; or if the control panel, work top or plinth area are damaged such that the inside of the appliance is freely accessible.
- Always plug the mains plug into a correctly installed shockproof socket.
- Permanent connection: a permanent connection must only be installed by a trained electrician.
- Prior to using the appliance for the first time, ensure that the rated voltage and type of supply on the rating plate match that of the supply where the appliance is to be installed. The fuse rating is also to be found on the rating plate.
- Multi-way plugs / connectors and extension cables must not be used. This could constitute a fire hazard through overheating.
- The dishwasher's cable must only be replaced by a Service Force Engineer.
- A water inlet hose with safety valve must only be replaced by a Service Force Engineer.

Installing the Dishwasher

- The dishwasher must be installed on a firm floor and adjusted to ensure that it is stable and level in all directions.
- To compensate for unevenness in the floor and to match the height of the appliance to that of surrounding units, extend the threaded feet using a screwdriver.
- The drain hose, inlet hose and mains cable must be laid so that they are able to move freely within the plinth area, and so that they are not kinked or crushed when the dishwasher is in position.
- The dishwasher must also be screwed tightly to the work surface or to the adjoining units. This is essential to ensure the dishwasher does not tip up.

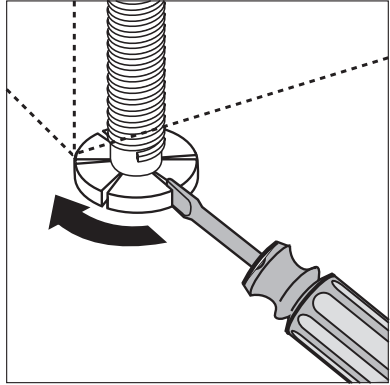

Free-standing appliances



If the dishwasher is installed directly next to a cooker, a heat-insulating, non-flammable panel (laminated with aluminium foil on the side next to the cooker) must be fitted flush with the top edge of the work surface (depth 57.5 cm).

If the appliance is built-in under a kitchen work surface, the worktop supplied with the dishwasher can be removed in the following way:

1. Unscrew the screws from the elbows at the rear (1).
2. Push the appliance's worktop backwards about 1 cm (2).

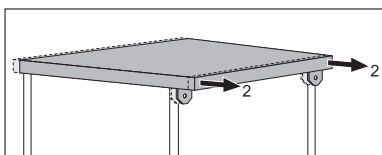
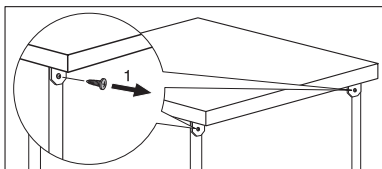

3. Lift the worktop at the front (3) and remove it.

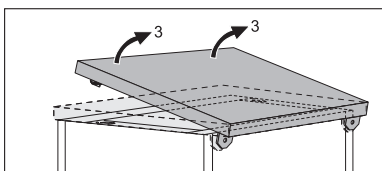

If the dishwasher is later used as a free-standing appliance, the work surface supplied with it must be re-mounted.



The plinth on free-standing appliances is not adjustable.

Connecting the dishwasher

Connecting to the water supply

- The dishwasher can be connected to cold and hot water supplies up to max. 60°C.
- The dishwasher must not be connected to open hot water appliances or instantaneous water heaters.

Permitted water pressure

Lowest permitted water pressure: 1 bar (=10 N/cm ² =100 kPa)	Consult your plumber if the water pressure is less than 1 bar.
Highest permitted water pressure: 10 bar (=100 N/cm ² =1 MPa)	If the water pressure is greater than 10 bar, a pressure reduction valve must be used (available from your dealer).

Connecting the inlet hose



The water inlet hose must not be kinked, crushed or entangled when it is being connected.

Connect the threaded hose fitting (ISO 228-1:2000) on the water inlet hose to a tap with an external thread (¾ inch). The inlet hose is fitted with either a plastic or a metal nut:

- **Only** tighten the **plastic** nut **hand tight**.
- You must tighten the **metal** nut **using a tool**.

Then do a visual check for water tightness (make sure that the tap is not dripping).



So that access to the tap in the kitchen is not restricted by the use of the dishwasher, we recommend installing an additional tap, or fitting a T-branch to the existing tap.

If you need a longer water inlet hose than that supplied, the following VDE-approved complete hose sets are to be used. These are available from your local service centre.

Water drainage

Drain hose



The drain hose must not be kinked, crushed or entangled.

Connecting the drain hose:

- Maximum permitted height: 1 metre.
- Minimum required height: 40 cm above the bottom edge of the appliance.

Extension hoses

- Extension hoses are available from your local Service Force Centre. To ensure that the function of the appliance is not impeded, the internal diameter of extension hoses must be 19 mm.
- Extension hoses must not be laid more than a maximum distance of 3 metres horizontally; the maximum permitted height for the connection for the drain hose is then 85 cm.

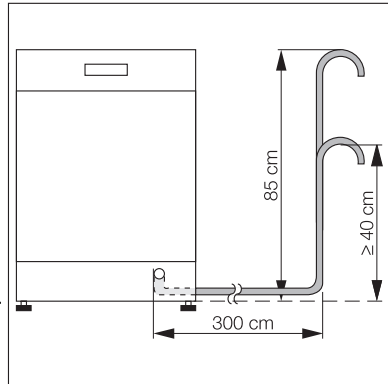

Sink outlet connection

- The outlet of the drain hose (\varnothing 19 mm) fits all commonly available sink outlet types. The outer diameter of the sink outlet connection must be at least 15 mm.
- The drain hose must be fixed to the sink outlet connection using the hose clamp supplied.

Water drainage if the dishwasher is built-in at high level

If the dishwasher is installed at a high level, and the drain hose connection is less than 30 cm from the lower edge of the appliance, adapter kit ET 111099520 must be fitted by your local Service Force Centre.

Water drainage into sink (only possible with free-standing appliances)

If you wish to hang the drain hose over the edge of a sink, use a detachable hose elbow. You can obtain this from AEG Service Force by referring to spare part number ET 646 069 190.

1. Fit the elbow to the drain hose.
2. Secure the drain hose so that it cannot slide off the edge of the sink. Pass a piece of cord through the hose elbow and fix it to the wall or the tap.

Anti-flood system

For protection from water damage, the dishwasher is equipped with an anti-flood system.

In the event of a fault, the safety valve in the water inlet hose immediately interrupts the supply of water to the appliance and the drain pump is activated. In this way water can neither escape nor overflow. The remaining water in the appliance is automatically pumped out.

Electrical Connection

Any electrical work required to install this appliance should be carried out by a qualified electrician or competent person.



WARNING – This appliance must be earthed.

The manufacturer declines any responsibility should these safety measures not be observed.

Before switching on make sure the electricity supply voltage is the same as that indicated on the appliance rating plate.

To isolate the dishwasher from the mains, remove the mains plug.

Important: The plug must still be accessible after the appliance has been installed.

Changing a fuse

The appliance is supplied with a 13amp plug fitted. In the event of having to change the fuse in the plug supplied, a 13amp ASTA approved (BS 1363A) fuse must be used.

Should the plug need to be replaced for any reason, proceed as described below.

The wires on the mains lead are coloured in accordance with the following code.

Green and Yellow:	Earth
Blue:	Neutral
Brown:	Live

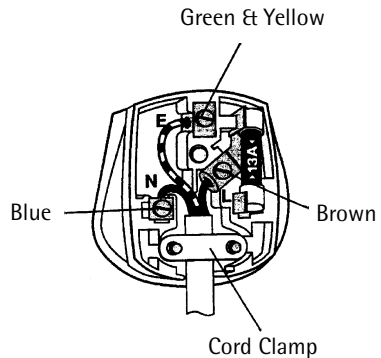

- The wire coloured green and yellow must be connected to the terminal marked with the letter "E" or by the earth symbol \oplus or coloured green and yellow.
- The wire coloured blue must be connected to the terminal "N" or coloured black.
- The wire coloured brown must be connected to the terminal marked "L" or coloured red.
- Upon completion there must be no cut, or stray strands of wire present and the cord clamp must be secure over the outer sheath.



WARNING! A cut off plug inserted into a 13 amp socket is a serious safety (shock) hazard. Ensure that, if it is necessary to cut off the plug, it is disposed of safely and not retained.

Connecting systems

The water inlet hose, drain hose and the mains cable must all be connected to the side of the dishwasher as there is no space for them behind the appliance.

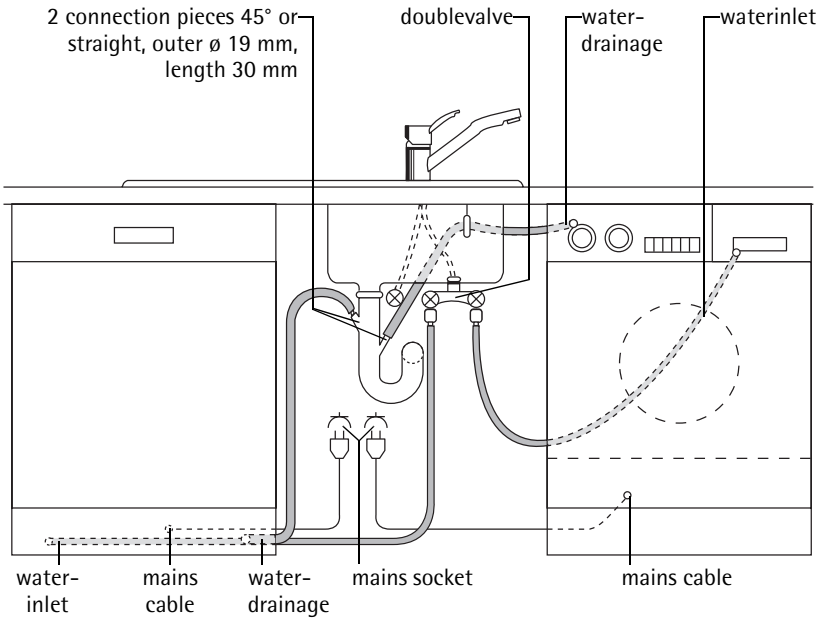

Warranty conditions

Great Britain

Standard guarantee conditions

We, AEG, undertake that if within 12 months of the date of the purchase this AEG appliance or any part thereof is proved to be defective by reason only of faulty workmanship or materials, we will, at our discretion repair or replace the same FREE OF CHARGE for labour, materials or carriage on condition that:

- The appliance has been correctly installed and used only on the electricity or gas supply stated on the rating plate.
- The appliance has been used for normal domestic purposes only, and in accordance with the manufacturer's operating and maintenance instructions.
- The appliance has not been serviced, maintained, repaired, taken apart or tampered with by any person not authorised by us.
- All service work under this guarantee must be undertaken by a Service Force Centre. Any appliance or defective part replaced shall become the Company's property.
- This guarantee is in addition to your statutory and other legal rights.
- Home visits are made between 8.30am and 5.30pm Monday to Friday. Visits may be available outside these hours in which case a premium will be charged.

Exclusions

This guarantee does not cover:

- Damage or calls resulting from transportation, improper use or neglect, the replacement of any light bulbs or removable parts of glass or plastic.
- Costs incurred for calls to put right an appliance which is improperly installed or calls to appliances outside the United Kingdom.
- Appliances found to be in use within a commercial environment, plus those which are subject to rental agreements.
- Products of AEG manufacture which are not marketed by AEG.

European Guarantee

If you should move to another country within Europe then your guarantee moves with you to your new home subject to the following qualifications:

- The guarantee starts from the date you first purchased your product.
- The guarantee is for the same period and to the same extent for labour and parts as exists in the new country of use for this brand or range of products.
- This guarantee relates to you and cannot be transferred to another user.
- Your new home is within the European Community (EC) or European Free Trade Area.
- The product is installed and used in accordance with our instructions and is only used domestically, i.e. a normal household.
- The product is installed taking into account regulations in your new country.

Before you move please contact your nearest Customer Care centre, listed below, to give them details of your new home. They will then ensure that the local Service Organisation is aware of your move and able to look after you and your appliances.

France	Senlis	+33 (0) 3 44 62 29 29
Germany	Nürnberg	+49 (0) 800 234 7378
Italy	Pordenone	+39 (0) 800 117511
Sweden	Stockholm	+46 (0) 8 672 5360
UK	Slough	+44 (0) 1753 219899

Service and Spare Parts

If the event of your appliance requiring service, or if you wish to purchase spare parts, please contact Service Force by telephoning:

0870 5 929 929

Your telephone call will be automatically routed to the Service Force Centre covering your post code area.

For the address of your local Service Force Centre and further information about Service Force, please visit the website at

www.serviceforce.co.uk

Before calling out an engineer, please ensure you have read the details under the heading „What to do if...“

When you contact the Service Force Centre you will need to give the following details:

1. Your name, address and post code.
2. Your telephone number.
3. Clear and concise details of the fault.
4. The model and serial number of the appliance (found on the rating plate)
5. The purchase date.

Please note that a valid purchase receipt or guarantee documentation is required for in-guarantee service calls.

Customer Care

For general enquiries concerning your AEG appliance, or for further information on AEG products please contact our Customer Care Department by letter or telephone at the address below or visit our website at **www.aeg.co.uk**.

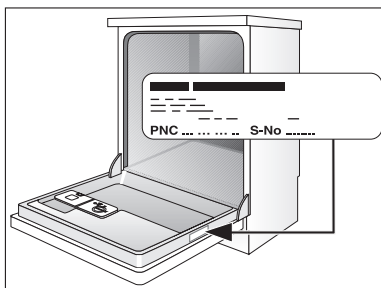

Customer Care Department
AEG Domestic Appliances
55-77 High Street
Slough
Berkshire, SL1 1DZ
Tel: 08705 350350 (*)

For Customer Service in the Republic of Ireland please contact us at the address below:

AEG/ Electrolux Group (Ire) Ltd
Long Mile Road/ Dublin 12
Republic of Ireland
Tel: +353 (0) 1 4090751
Email: service.eid@electrolux.ie

(*) Calls may be recorded for training purposes

 **From the Electrolux Group. The world's No. 1 choice.**

The Electrolux Group is the world's largest producer of powered appliances for kitchen, cleaning and outdoor use. More than 55 million Electrolux Group products (such as refrigerators, cookers, washing machines, vacuum cleaners, chain saws and lawn mowers) are sold each year to a value of approx. USD 14 billion in more than 150 countries around the world.

AEG Hausgeräte GmbH
Postfach 1036
D-90327 Nürnberg

<http://www.aeg.hausgeraete.de>

© Copyright by AEG

822 961 160-00-190504-03

Subject to change without notice