

D i s h w a s h e r

# INSTRUCTION BOOK

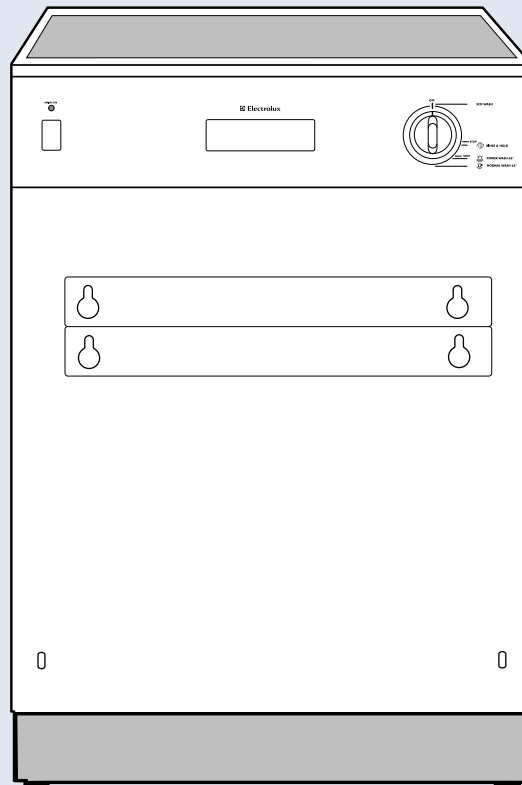

*Model ESI 600*



# Important safety information

**It is most important that this instruction book should be retained with the appliance for future reference. Should the appliance be sold or transferred to another owner, or should you move house and leave the appliance, always ensure that the book is left with the appliance in order that the new owner can get to know the functioning of the appliance and the relevant safety information.**

**This information has been provided in the interest of safety. You MUST read it carefully before installing or using the appliance.**

## Installation

- This appliance is heavy. Care should be taken when moving it.
- It is dangerous to alter the specifications or attempt to modify this product in any way.
- Care must be taken to ensure that the appliance does not stand on the electrical supply cable.
- Any electrical work required to install this appliance should be carried out by a qualified electrician or competent person.
- Any plumbing work required to install this appliance should be carried out by a qualified plumber or competent person.

## Child Safety

- This appliance is designed to be operated by adults. Children should not be allowed to tamper with the controls or play with the product.
- Keep all packaging well away from children.
- Keep all detergents in a safe place out of children's reach.

## During Use

- Items that are contaminated by petrol, paint, steel or iron debris, corrosive, acidic or alkaline chemicals must not be washed in this dishwasher.
- Under no circumstances should you open the door whilst the appliance is in operation. Always turn off the appliance before opening the door.
- Only use detergent specifically designed for use in dishwashers.
- Long blades knives stored in an upright position are a potential hazard.
- Long and/or sharp items of cutlery such as carving knives must be positioned horizontally in the upper basket.

- When finishing loading or unloading close the door, as an open door can be a hazard.
- Do not sit or stand on the open door.
- Isolate the appliance from the power supply and turn off the water supply after use.
- Care should be taken when cleaning the bottom door seal and hinge area as any exposed metal edges may cut if care is not taken.
- This product should be serviced by an authorised Service engineer, and only genuine spare parts should be used.
- Under no circumstances should you attempt to repair the machine yourself. Repairs carried out by inexperienced persons may cause injury or serious malfunctioning. Contact your local Service Force Centre. Always insist on genuine spare parts.

## Conservation

### In the interest of the environment:

- Materials marked with the symbol  are recyclable.
- Check with your local Council or Environmental Health Office to see if there are facilities in your area for re-cycling this appliance.
- When the appliance is to be scrapped, cut off the power supply cable and make the door closing device unusable to prevent young children from being trapped inside.
- Help to keep your country tidy - use authorised disposal sites for your old appliance.

# Contents

## For the user

<b>Important safety information</b>	2
<b>Guide to use the instruction book</b>	3
<b>Description of the appliance</b>	4
<b>The control panel</b>	5
<b>Before use</b>	6
Setting the water softener	6
Rinse aid	8
Use of detergent	9
<b>Using your appliance</b>	10
Loading your appliance	10
Adjusting the height of the upper basket	11
<b>Hints and tips</b>	12
<b>Washing programmes</b>	13
<b>Operating sequence</b>	14
<b>Maintenance and cleaning</b>	15
Internal cleaning	15
Cleaning the central filters	15
Cleaning the large filter	15
External cleaning	16
Prolonged periods of non-operation	16
Frost precautions	16
Moving the machine	16
<b>Something not working</b>	17
Service and spare parts	18
<b>Guarantee Conditions</b>	19
<b>Electrolux Service Force</b>	20

## For the installer

<b>Installation instruction</b>	22
Technical specifications	22
Water supply connections	23
Water outlet hose connection	24
Electrical connection	25
<b>Building-in</b>	26
Levelling	26
The furniture door	27
Adjusting the door balance	28
Securing under a counter	28
Kitchen plinth adjustment	29

## Guide to use the instruction book

The following symbols will be found in the text to guide you throughout the instructions:



**Safety instructions**



**Step by step instructions**



**Hints and tips**



**Environmental information**

# Description of the appliance

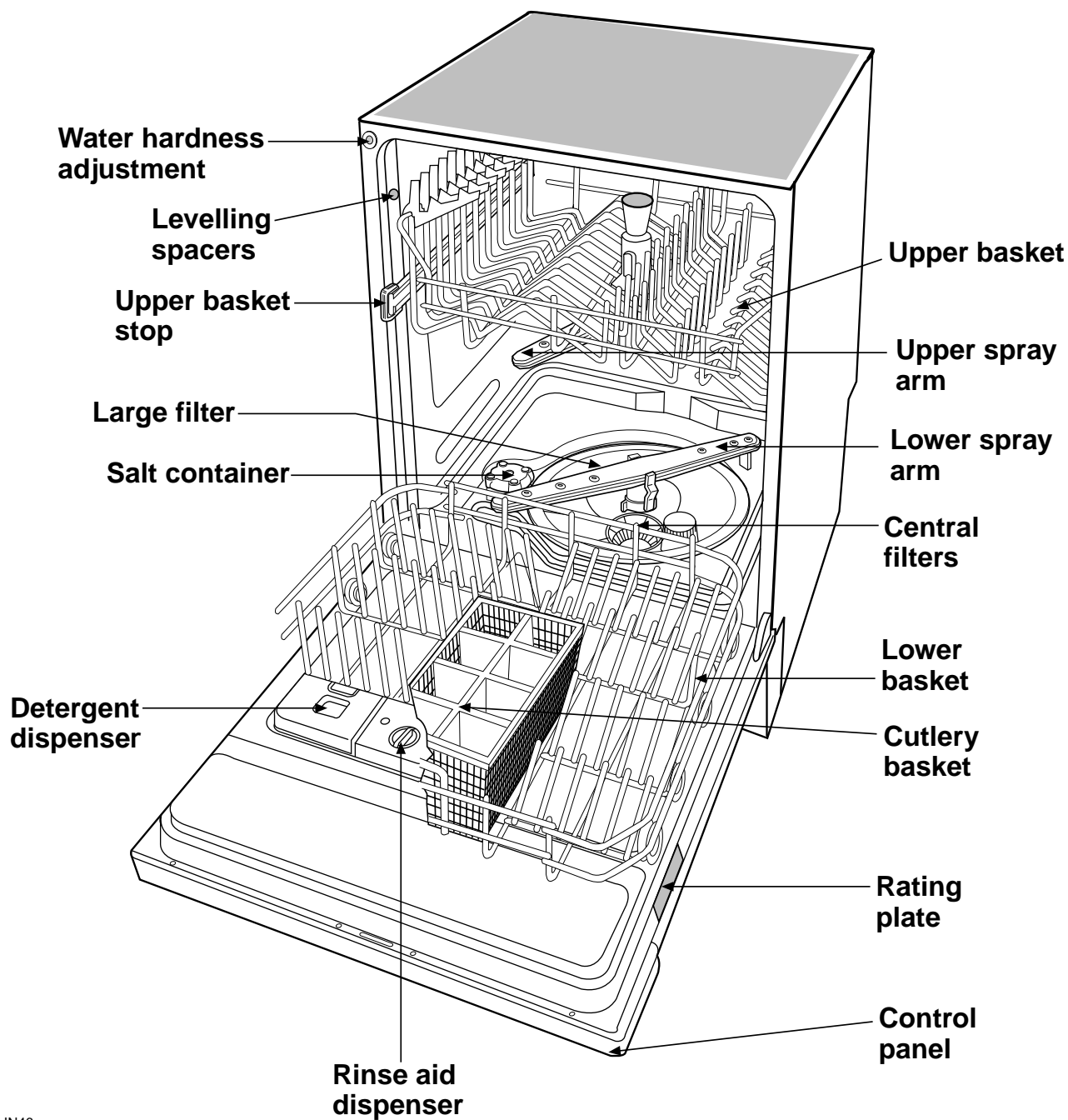

IN46

# The control panel

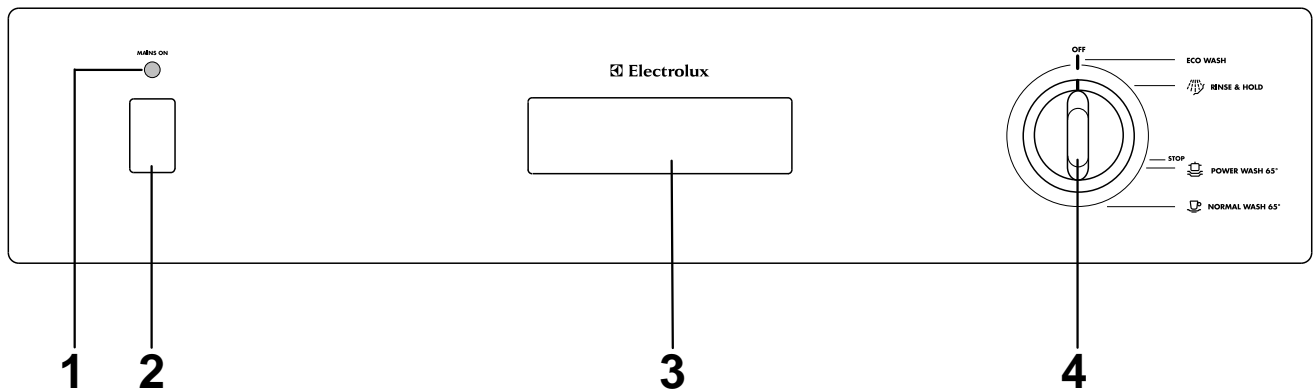

## 1. On/Off indicator light

## 2. On/Off pushbutton

### **On**

By depressing this button the machine starts operating and, at the same time the On/Off indicator light illuminates.

### **Off**

When the washing programme has finished, the machine stops automatically and the indicator light remains on.

To switch the indicator light off or to stop the machine at any time, press this button.

## 3. Door handle

To open the door press the catch in the top of the recess and pull toward you at the same time.

To close the door simply push it.

## 4. Programme selector dial

To select a programme, turn the programme selector dial clockwise, making sure that the marker on the knob corresponds with the programme you wish to select.

At the end of the programme the machine will stop automatically and the On/Off indicator light remains on until the On/Off pushbutton is depressed.

# Before use

Before using your dishwasher for the first time:

- ☞ ensure that the electrical and water connections comply with the installation instructions
- ☞ remove all packaging from inside the appliance
- ☞ set the water softener
- ☞ fill the salt container
- ☞ fill the rinse aid dispenser.

## Setting the water softener

The dishwasher is equipped with a water softener designed to remove minerals and salts from the water supply, which would have a detrimental or adverse effect on the operation of the appliance.

The higher the content of these salts, the harder your water is.

Water hardness is measured in equivalent scales, Clarke degrees and French degrees.

The softener should be adjusted according to the hardness of the water in your area. Your local Water Authority can advise you on the hardness of the water in your area.

The dishwasher is factory set at level 2.

If this level is not suitable for your area the softener should be adjusted.

Water hardness		Level	Water softener adjustment	Adjustment on the machine
Clarke degrees	French degrees			
0 - 10	0 - 14	1	NO	NO
11 - 27	15 - 39	*2	NO	NO
28 - 35	40 - 50	3	YES	NO
36 - 49	51 - 70	4	NO	YES
50 - 63	71 - 90	5	YES	YES

\* factory setting

### ☞ To adjust the water softener:

#### Level 1

If your water is "level 1" it is already soft and therefore there is no need to use salt.

#### Levels 3 and 5

(water softener adjustment)

If your water is level 3 or 5, proceed as follows:

- slide out the lower basket and unscrew the cap of the salt container;
- turn the two-position selector anticlockwise from position - to position + with the aid of a knife or screwdriver.

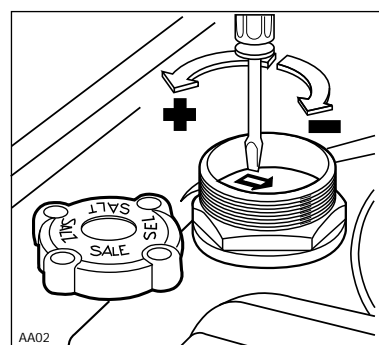

#### Levels 4 and 5

(adjustment on the machine)

If your water is level 4 or 5, open the door and drill membrane (A) on the upper left-hand corner of the machine.

With a water hardness of level 5 both adjustments must be made.

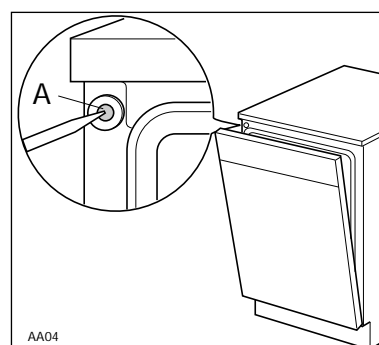

# Filling with salt

Salt must be used from level 2 upward.



**Only use salt specifically designed for use in dishwasher.**

**All other types of salt not specifically designed for use in dishwasher, specifically table salt, will damage the water softener.**

Only fill with salt just before starting one of the complete washing programmes (not the Rinse and Hold programme). This will prevent any grains of salt or salty water, which may have been spilled, remaining on the bottom of the machine for any period of time, which may cause corrosion.

## **To fill:**

- 1.** To fill with salt, unscrew the cap of the salt container.
- 2.** Pour about 1 litre of water inside the container, or until it is full (this is necessary only before filling with salt for the first time).
- 3.** Then using the funnel provided, pour in the salt until the container is full (approx. 1.5 - 1.8 kg).  
Do not worry if water over flows from the unit when filling with salt, this is quite normal.
- 4.** Replace the cap making sure that there is no trace of salt on the screw thread or on the gasket.
- 5.** Screw on the cap tightly.

The salt container will require topping up periodically. The salt cap has a refill indicator window in the centre. A green float is clearly visible when there is salt inside the container, and almost disappears when the salt has finished, (ie. every 30 - 50 washes depending on the setting of the water softener) reminding you to add salt.

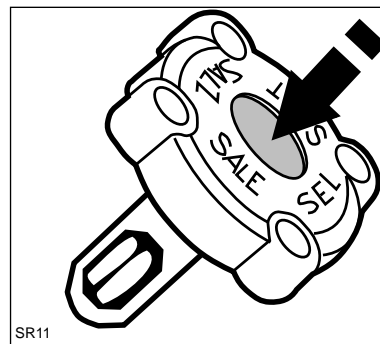
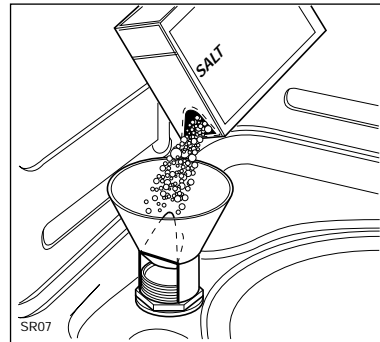

# Rinse aid

Rinse aid is automatically added during the last rinse, ensuring thorough rinsing, spot and streak free drying. The dispenser, which is positioned inside the door, holds about 110 ml of rinse aid, which is sufficient for 16 - 40 dishwashing programmes, depending upon the dosage setting.

## Filling with Rinse Aid:

1. Open the container by turning the lid (A) anticlockwise.
2. Add the rinse aid until the container is completely full (approx. 110 ml). The indicator (B) will be completely dark.
3. Top up the rinse aid when the indicator (B) becomes clear.

## Ensure that the lid is closed after every refill.

Do not put liquid detergent in the rinse aid department. Clean up any rinse aid spilt during filling with an absorbent cloth to avoid excess foaming during the next wash.

## Adjusting the dose

According to the finish and drying results obtained, adjust the dose of rinse aid by means of the 6 position selector (C) (position 1 minimum dosage, position 6 maximum dosage). (Start from position 3). Gradually increase the dose if there are drops of water or lime spots on the dishes after washing. Reduce it if there are sticky whitish streaks on the dishes.

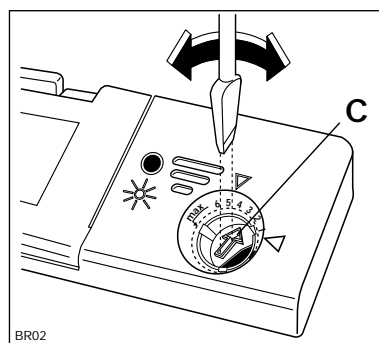
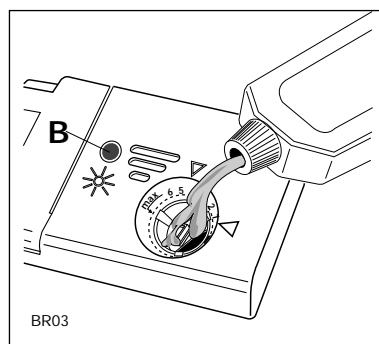
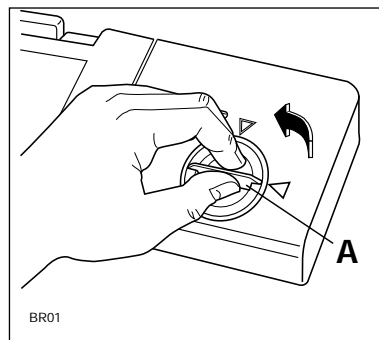



# Use of detergent

**i** Only use detergents specifically designed for use in dishwashers.

We recommend the use of Finish detergents which are available in the following options:

**Finish Double Action Tablets.** Each tablet has the exact amount of detergent required, simply place in the dispenser.

**Finish Powder** recommended for every day use.

**Finish liquid Gel** ideal for every day use. As the gel is extra gentle it is recommended for fine bone china.

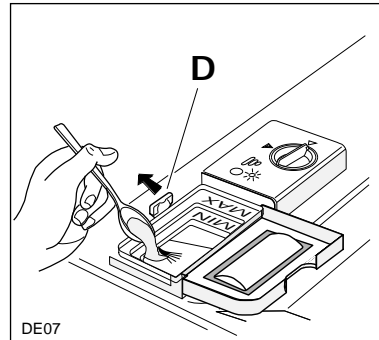

**To fill the dishwasher with detergent proceed as follows:**

1. Open the dispenser lid by pulling the catch (D).
2. Add the detergent according to the recommendations in the programme chart. As all detergents are not the same, you should also consult the instructions on the packet. To help correctly dose the right amount of detergent, inside the container there are two reference marks:
  - MIN = 15 ml
  - MAX = 30 ml
3. Always close the lid.
4. If the programme has a prewash add the required detergent over the lid of the dispenser.

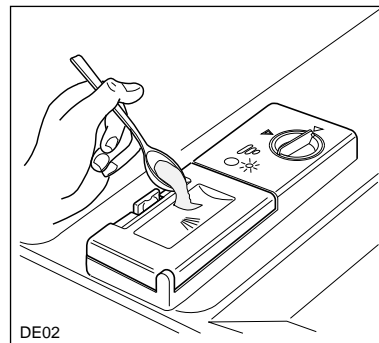

▲ Insufficient quantities of detergent will produce poor washing results, whereas an excessive amount of detergent will not improve washing results and is also wasteful. Using no more than the correct amount also contributes to reducing pollution.

# Using your appliance

## Loading your appliance

Before placing dishes in the machine, remove any scraps of food, to avoid clogging the filters and consequently reducing the performance.

**i** Do not load very small items which can fall through the baskets.

Open the door and slide out the baskets to load the dishes.

## The lower basket

The lower basket is designed to take saucepans, lids, plates (up to 27 cm in diameter), salad bowls, cutlery etc.

Serving dishes and large lids should be arranged around the edge of the basket, ensuring that the upper spray arm can turn freely.

## The cutlery basket

**!** Long bladed knives stored in an upright position are a potential hazard.

**Long and/or sharp items of cutlery such as carvings knives must be positioned horizontally in the upper basket.**

**Take care when loading or unloading sharp items such as knives.**

Cutlery should be placed in the removable cutlery basket with the handles facing downwards. If the handles protrude from the bottom of the basket, obstructing the lower spray arm, load the cutlery with the handles facing upwards.

Mix spoons with other cutlery to prevent them from sticking together.

Silver cutlery tends to go black if mixed with steel cutlery. Place it in the cutlery basket separate from the others.

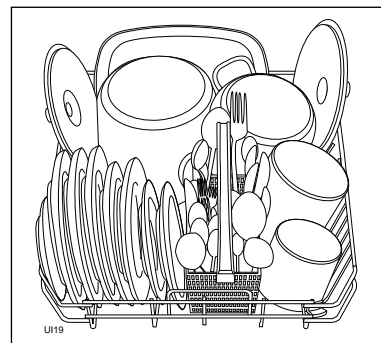
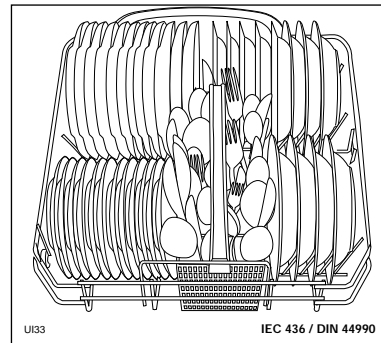

# The upper basket

The upper basket is designed for plates (dessert plates, saucers, dinner plates of up to 24 cm in diameter), salad bowls, cups and glasses; Glasses with long stems can be placed upside down in the raised cup racks.

Larger plates (dinner plates up to 24 cm in diameter) must be loaded in the front part of the upper basket.

Light items (plastic bowls etc.) should be loaded in the upper basket and arranged so they do not move.

**i** When loading the dishes, ensure that you do not cover the water inlet funnel in the middle of the upper basket.

Before closing the door, ensure that the spray arms can rotate freely.

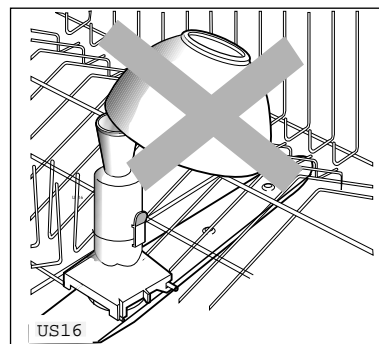
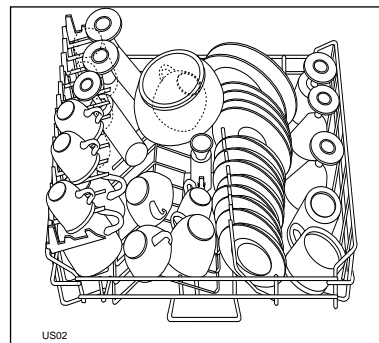
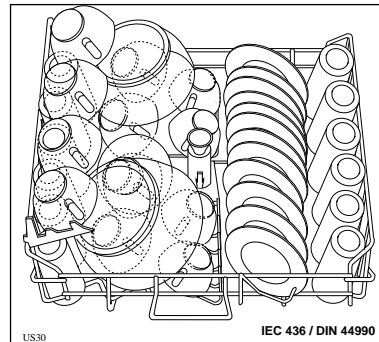

# Adjusting the height of the upper basket

If washing very large plates (over 27 cm and up to 31 cm in diameter) you can load them in the lower basket after moving the upper basket to the higher position.

To move to the higher position proceed as follows:

1. Move the front runner stops (A) of the upper basket outward and slide the basket out.
2. Refit the basket in the higher position and replace the stops (A) in their original position.

**i** When the top basket is in the higher position it will only take plates up to 20 cm in diameter and you will not be able to use the raised cup racks.

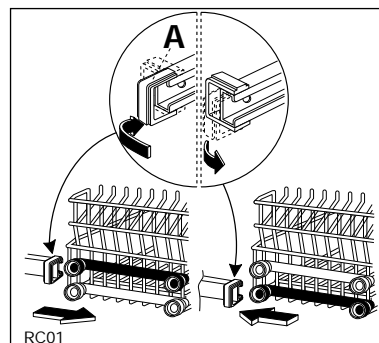

**!** After loading your machine always close the door, as an open door can be a hazard.

# Hints and tips

## To save energy

Place dishes in the machine immediately after every meal and wait until the dishwasher is full before washing.

If necessary run the Rinse and Hold programme (see "Washing Programmes" chart on the following page), so that any food scraps do not become caked on the dishes while you are waiting to run the complete wash programme.

Do not prewash dishes under running water.

## For best washing results:

Before loading remove all scraps of food and soak very heavily soiled pots and pans.

Arrange saucepans, cups and glasses etc. upside-down.

Tilt items with convex or concave surfaces so that the water drains off easily.

Avoid contact between the dishes as far as possible.

You will improve drying results by leaving the dishwasher door ajar for at least 15-30 minutes as soon as the programme finishes.

Wait a few minutes before removing the dishes; in this way they will be cooler and the drying will be improved.

Empty the lower basket first and then the upper one; this will avoid water dripping from the upper basket onto the dishes in the lower one.

## Items not suitable for dishwashers:

**The following items should not be washed in the dishwasher (unless they are sold as dishwasher proof):**

- Cutlery with wooden or horn handles or glued parts
- bronze cutlery
- saucepans with wooden handles
- aluminium ware
- crystal ware
- leaded glass
- plastic items
- antique or fine decorated china

Certain types of decoration can discolour when washed in a dishwasher.

Crystal-ware and plastic objects, if not guaranteed dishwasher proof should be washed by hand.

Certain types of glass can also become opaque after being washed several times in a dishwasher.

A chemical reaction can occur between silver cutlery and stainless steel cutlery. As a precaution, do not wash together.



Iron and cast iron objects can rust and stain other items.

Aluminium tends to go black, copper, pewter and brass tend to stain.

***i* If in doubt check with manufacturer of the item.**

***i* When buying new dishes, ensure that they are dishwasher proof.**

# Washing programmes

Programme	Degree of soil and type of load	Starting position of the programmer	Required pushbuttons	Recommended quantity of detergent		Cycle description
				in the dispenser	on the dispenser lid	
<b>* POWER WASH 65°C</b>	Heavy soil. Crockery, cutlery pots and pans	 POWER WASH 65°C	<b>On Off</b>	25 g	5 g	Cold prewash Main wash up to 65°C 2 cold rinses 1 hot rinse up to 65°C
<b>NORMAL WASH 65°C</b>	Normal soil. Crockery and cutlery	 NORMAL WASH 65°C	<b>On Off</b>	25 g	/	Main wash up to 65°C 2 cold rinses 1 hot rinse up to 65°C
<b>** ECO WASH</b>	Normal soil. Crockery and cutlery	ECO WASH	<b>On Off</b>	25 g	/	Main wash up to 65°C 2 cold rinses
<b>RINSE AND HOLD</b>	Any. Partial load (to be completed later in the day).	 RINSE & HOLD	<b>On Off</b>	/	/	1 cold rinse

**\* Testing programme according to IEC 436/DIN 44990**

Standard place settings: 12.

Rinse aid selector on position 3.

Recommended quantity of detergent: 25 g in the dispenser  
5 g on the dispenser lid.

**\*\*** This is a special programme for quick washing (approx. 32 minutes) a full load of lightly soiled crockery etc.

For best results we recommend the use of Finish detergents, rinse aid and salt.



DE15

# Operating sequence

## 1. Check the filters

Ensure they are clean and properly positioned (see cleaning instructions).

## 2. Check that there is rinse aid and salt

## 3. Load the dishes

Remove any scraps of food.

Pull the lower basket out and arrange the saucepans, plates and cutlery in it.

Pull the upper basket out and arrange the plates, saucers, glasses and cups etc. in it.

Slide the basket back into the machine.

## 4. Ensure that the spray arms can rotate freely.

## 5. Measure out detergent

Add the required amount of detergent into the dispenser according to the "Washing programmes" chart and close the lid.

## 6. Close the detergent dispenser lid

## 7. Select the programme

Close the door.

Turn the programme selector dial clockwise until the marker on the knob corresponds with the programme you wish to select.

## 8. Start the programme

Depress the On/Off pushbutton. The On/Off indicator light comes on and the machine will start.

## 9. At the end of the washing programme

At the end of the washing programme the dishwasher stops automatically. The On/Off indicator light remains on until the On/Off pushbutton is depressed.

## 10. Switch off the dishwasher

Switch off the dishwasher by pressing the On/Off pushbutton.

** When the wash programme has finished, it is recommended that the dishwasher is unplugged and the water tap turned off.**

** In general it is not advisable to open the door while the machine is working; if the door is opened however, a safety device ensures that the machine stops.**

** Care must be taken if the door is opened during the hot phase or immediately after a programme has finished, as steam may escape.**

# Maintenance and cleaning

## Internal cleaning

Ensure that the seals around the door, the detergent and rinse aid dispensers are cleaned regularly with a damp cloth.

We recommend the use of Finish Dishwasher Cleaner every 3 months or run a 65°C wash without dishes using detergent. Regular use of Finish Dishwasher Cleaner cleans inaccessible parts, eliminates unpleasant food odours and helps prevent the build-up of limescale.

## Cleaning the central filters

(After each wash)

Inspect the central filters (B) and (C) and remove any scraps of food with a brush, under running water.

Filters (B) and (C) are both removed by lifting up the outer one (B) (pulling the central funnel upwards); the smaller filter (C) can be removed by pressing the two tongues (D).

**Once cleaned, refit the filters by pressing them down until they click into place.**

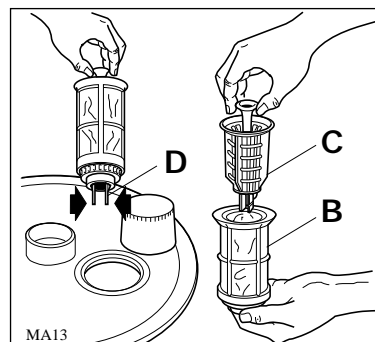

## Cleaning the large filter

(Once a month)

Clean the large filter (A) on both sides under running water, using a brush.

To take it out, remove the spray arm by pressing the two tongues (E), turn the ring (F) anticlockwise and then slide the whole part out. Refit the filter following the above instructions in reverse order.

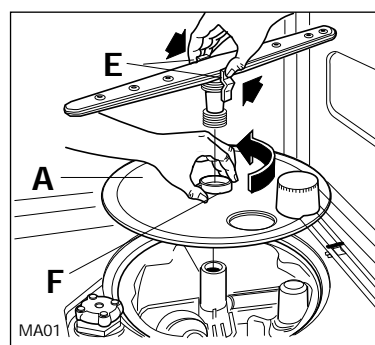
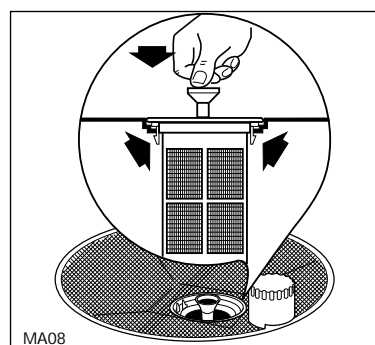

**i** **The dishwasher must not be used without filters.**

**Incorrect repositioning and fitting of the filters will produce poor washing results.**

**Cleaning the filters is vital to ensure correct operation of the machine.**

## External cleaning

Clean the external surfaces of the machine and control panel with a damp soft cloth. If necessary use only neutral detergents. Never use abrasive products, scouring pads or solvent (acetone, trichloroethylene etc....).

## Prolonged periods of non-operation

**If you are not using the machine for any period of time you are advised to:**

1. Unplug the appliance and then turn off the water;
2. Fill the rinse aid dispenser;
3. Leave the door ajar to prevent the formation of any unpleasant smells;
4. Leave the inside of the machine clean.

## Frost precautions

Avoid placing the machine in a location where the temperature is below 0°C. If this is unavoidable, empty the machine, close the appliance door, disconnect the water inlet pipe and empty it.

## Moving the machine

**If you have to move the machine (moving house etc....):**

1. Unplug it;
2. Turn the water tap off;
3. Remove the water inlet and discharge hoses;
4. Pull the machine out together with the hoses.

Avoid over tilting the machine during transport.



# Something not working

Certain problems are due to lack of simple maintenance or oversights, which can be solved easily without calling out an engineer. Before contacting your local Service Force Centre, please carry out the checks listed below.

Symptom	Solution
<b>The machine will not start</b>	<ul style="list-style-type: none"> <li>■ The door has not been properly closed.</li> <li>■ The plug is not properly inserted in the power socket.</li> <li>■ Check the plug fuse.</li> <li>■ There is not current at the socket.</li> </ul>
<b>The dishwasher does not fill with water</b>	<ul style="list-style-type: none"> <li>■ Ensure the water tap is open.</li> <li>■ Ensure the mains water supply has not been cut off.</li> <li>■ The inlet hose may be squashed or bent. Reposition the hose.</li> <li>■ The inlet hose may be blocked. Switch off the water supply, and clean the filter.</li> </ul>
<b>The filters are blocked</b>	<ul style="list-style-type: none"> <li>■ Clean the filters (refer to “Maintenance and cleaning”).</li> </ul>
	<ul style="list-style-type: none"> <li>■ The spray arms are not rotating. Ensure the crockery is loaded correctly.</li> </ul>
<b>The dishwasher will not drain</b>	<ul style="list-style-type: none"> <li>■ The drain hose may be squashed or bent. Reposition the hose.</li> <li>■ The sink may be blocked. Clear any blockages.</li> <li>■ The drain hose extension is not correct. Follow the instructions for connecting to the waste.</li> <li>■ There is no vent in the end of the drain hose.</li> </ul>
<b>The machine is noisy</b>	<ul style="list-style-type: none"> <li>■ Dishes are rattling against each other, (refer to “Loading your machine”).</li> <li>■ The spray arms are knocking against the dishes.</li> </ul>
<b>The door is difficult to close</b>	<ul style="list-style-type: none"> <li>■ The dishwasher is not level, or not properly built-in.</li> </ul>
<b>The dishes are not clean (poor wash)</b>	<ul style="list-style-type: none"> <li>■ The baskets are too full.</li> <li>■ The dishes have not been arranged properly.</li> <li>■ The spray arms do not rotate.</li> <li>■ The spray arms are clogged.</li> <li>■ The filters are clogged.</li> <li>■ The filters are not in position.</li> <li>■ Not enough detergent has been used or it is unsuitable.</li> <li>■ The detergent is old or has gone hard.</li> <li>■ The salt container cap is not properly closed.</li> <li>■ The washing programme selected is too gentle.</li> </ul>
<b>Visible lime deposits or white film on the dishes</b>	<ul style="list-style-type: none"> <li>■ The rinse aid has run out or too little is being used.</li> <li>■ Check that there is salt and that the salt cap is tight.</li> <li>■ Ensure the water softener has been adjusted to suit the water hardness in your area.</li> </ul>
<b>The dishes are not quite dry</b>	<ul style="list-style-type: none"> <li>■ The dishes have been left too long inside the machine.</li> </ul>

If after all these checks, the problem persists, contact your local Service Force Centre, quoting the model and serial number. This information can be found on the rating plate located on the right hand side of the dishwasher door (see picture).

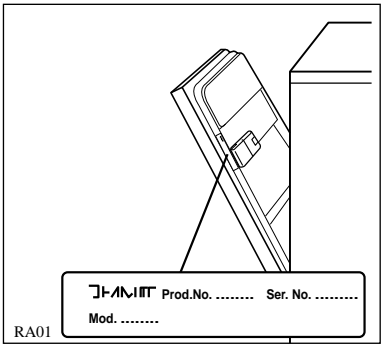

## Service and spare parts

In the event of your appliance requiring service, or if you wish to purchase spare parts please contact your local Electrolux Service Force Centre by telephoning:

**0990 929929**

Your telephone call will be automatically routed to the Service Centre covering your post code area. The addresses are listed on the following pages.

Before calling out an engineer, please ensure you have read the details under the heading “Something Not Working” and have the model number and purchase date to hand.

**Please note that it will be necessary to provide proof of purchase for any in-guarantee service calls. In-guarantee customers should ensure that the checks under the heading “Something Not Working” have been made as the engineer will make a charge if the fault is not a mechanical or electrical breakdown.**

## Customer Care Department

For general enquiries concerning your Electrolux appliance or for further information on Electrolux products please contact our Customer Care Department by letter or telephone as follows:

Customer Care Department  
Electrolux  
Newbury  
Berkshire  
RG145XL  
Tel: 01635 522 799

# Guarantee Conditions

## Standard guarantee conditions

We, Electrolux, undertake that if within 12 months of the date of purchase this Electrolux appliance or any part thereof is proved to be defective by reason only of faulty workmanship or materials, we will, at our option repair or replace the same FREE OF CHARGE for labour, materials or carriage on condition that:

- The appliance has been correctly installed and used only on the electricity supply stated on the rating plate.
- The appliance has been used for normal domestic purposes only, and in accordance with the manufacturer's instructions.
- The appliance has not been serviced, maintained repaired, taken apart or tampered with by any person not authorised by us.
- All service work under this guarantee must be undertaken by a Electrolux Service Force Centre.
- Any appliance or defective part replaced shall become the Company's property.
- This guarantee is in addition to your statutory and other legal rights.

Home visits are made between **8.30am** and **5.30pm** Monday to Friday. Visits may be available outside these hours in which case a **premium** will be charged.

## Exclusions

### **This guarantee does not cover:**

- Damage or calls resulting from transportation, improper use or neglect, the replacement of any light bulbs or removable parts of glass or plastic.
- Costs incurred for calls to put right an appliance which is improperly installed or calls to appliances outside the United Kingdom.
- Appliances found to be in use within a commercial environment, plus those which are subject to rental agreements.
- Products of Electrolux manufacture which are not marketed by Electrolux.

## European Guarantee

If you should move to another country within Europe then your guarantee moves with you to your new home subject to the following qualifications:

- The guarantee starts from the date you first purchased your product.
- The guarantee is for the same period and to the same extent for labour and parts as exists in the new country of use for this brand or range of products.
- This guarantee relates to you and cannot be transferred to another user.
- Your new home is within European Community (EC) or European Free Trade Area.
- The product is installed and used in accordance with our instructions and is only used domestically, i.e. a normal household.
- The product is installed taking in account regulations in your new country.

Before you move please contact your nearest Customer Care centre, listed below, to give them details of your new home. They will then ensure that the local Service Organisation is aware of your move and able to look after you and your appliance.

France	Senlis	+33 (0) 44 62 22 22
Germany	Nuremberg	+49 (0) 911 323 2600
Italy	Pordenone	+39 (0) 1678 47053
Sweden	Stockholm	+46(0) 20 78 77 50
UK	Newbury	+44 (0) 1635 522 799

# ELECTROLUX SERVICE FORCE

To contact your local Electrolux Service Centre telephone **0990 929929**

## CHANNEL ISLANDS

GUERNSEY Guernsey Electricity  
PO Box 4  
Vale, Guernsey  
Channel Islands

JERSEY Jersey Electricity  
Company  
PO Box 45  
Queens Road  
St Helier  
Jersey  
Channel Islands  
JE4 8NY

## SCOTLAND

ABERDEEN 8 Cornhill Arcade  
(M5) Cornhill Drive  
Aberdeen  
AB2 5UT

AUCHTERMUCHY 33A Burnside  
(M03) Auchtermuchy  
Fife  
KY14 7AJ

BLANTYRE Unit 5  
(M07) Block 2  
Auchenraith Ind Estate  
Rosendale Way  
Blantyre  
G72 0NJ

DUMFRIES 93Irish Street  
(M01) Dumfries  
Scotland  
DG1 2PQ

DUNOON Briar Hill  
(M67) 7 Hill Street,  
Dunoon  
Argyll  
PA23 7AL

GLASGOW 20 Cunningham Road  
(M04) Clyde Estate  
Rutherglen,  
Glasgow,  
G73 1PP

INVERNESS Unit 3B  
(M06) Smithton Indust. Est.  
Smithton  
Inverness  
IV1 AJ

ISLE OF ARRAN Arran Domestic  
Unit 4 The Douglas  
Centre  
Brodick  
(OWN SALES) Isle of Arran  
KA27 8AJ

ISLE OF BARRA J Zerfah  
(OWN SALES) 244 Bruernish  
Isle of Barra  
Western Islands  
HS9 5QY

ISLE OF BUTE Walker Engineering  
(M66) Glenmohr  
Upper Serpentine Road  
Rothesay  
Isle of Bute  
PA20 9EH

ISLE OF LEWIS ND Macleod  
(M69) 16 James Street  
Stornoway  
Isle of Lewis PA87 2QW

KELSO 2-8 Wood Market  
(M08) Kelso  
Borders TD5 7AX

ORKNEY Corsie Domestic  
(M65) 7 King Street  
Kirkwall  
Orkney KW15

SHETLAND Tait Electronic System  
Ltd.  
Holmsgarth Road  
Lerwick  
(OWN SALES) Shetland ZE1 0PE

SHETLAND Bolts Shetland Ltd  
26 North Road  
Lerwick  
(OWN SALES) Shetland ZE1 0PE

WHALSAY Leask Electrical  
Harlsdale  
Symbister, Whalsay  
(OWN SALES) Shetland ZE2 9AA

## NORTHERN IRELAND

BELFAST Owenmore House  
(M27) Kilwee Industrial  
Estate  
Upper Dunmury Lane  
Belfast  
BT17 0HD

## WALES

CARDIFF Guardian Industrial  
(M28) Estate  
Clydesmuir Road  
Tremorfa, Cardiff  
CF2 2QS

CLYWD Unit 6-7 Coed- Parc  
(M14) Abergele Road  
Rhuddlan  
Clywd  
Wales  
LL18 5UG

OSWESTRY Plas Ffynnon Warehouse  
(M17) Middleton Road  
Oswestry  
SY1 2PP

HAVERFORDWEST Cromlech Lodge  
(M75) Amerlston  
Haverfordwest  
SA62 5DS

## NORTH EAST

GATESHEAD Unit 356a  
(M39) Dukesway Court  
Dukesway  
Team Valley  
Gateshead  
NE 11 0BH

GRIMSBY Unit 2  
(M42) Cromwell Road  
Grimsby  
South Humberside  
DN31 2BN

HULL Unit 1  
(M41) Boulevard Industrial  
Estate  
Hull HU3 4AY

LEEDS 64-66 G Cross Gates  
(M37) Road  
Leeds LS15 7NN

NEWTON AYCLIFFE Unit 16  
(M45) Gurney Way  
Aycliffe Ind Estate  
Newton Aycliffe  
DL5 6UJ

SHEFFIELD Pennine House  
(M38) Roman Ridge Ind.  
Roman Ridge Road  
Sheffield S9 1GB

## NORTH WEST

BIRKENHEAD 1 Kelvin Park  
(M11) Dock Road  
Birkenhead L41 1LT

CARLISLE Unit 8  
(M10) South John Street  
Carlisle CA2 5AJ

ISLE OF MAN South Quay Ind Estate  
(M64) Douglas  
Isle of Man

LIVERPOOL Unit 1  
(M15) Honeys Green  
Precinct  
Honeys Green Lane  
Liverpool L12 9JH

MANCHESTER Unit 30, Oakhill  
(M09) Trading Estate  
Devonshire Road  
Worsley Manchester  
M28 3PT

PRESTON Unit 250  
(M13) Dawson Place  
Walton Summit  
Bamber Bridge  
Preston  
Lanashire PR5 8AL

STOCKPORT Unit 20 Haigh Park  
(M16) Haigh Avenue  
Stockport SK4 1QR

# ELECTROLUX SERVICE FORCE

To contact your local Electrolux Service Centre telephone **0990 929929**

## MIDLANDS

BIRMINGHAM (M18)	66 Birch Road East, Wyrley Road Industrial Estate Witton Birmingham B6 7DB
BOURNE (M44)	Manning Road Ind Estate Pinfold Road Bourne PE10 9HT
BRIDGNORTH (M72)	1 Underhill Street Bridgnorth Salop WV16 4BB
GLOUCESTER (M23)	101 Rycroft Street Gloucester GL1 4NB
HEREFORD (M31)	Unit 3 Bank Buildings Cattle Market Hereford HE4 9HX
HIGHAM FERRERS (M51)	The Old Barn Westfield Terrace Higham Ferrers NN10 8BB
ILKESTON (M43)	Unit 2 Furnace Road, Ilkeston DE7 5EP
LEICESTER (M22)	Unit 7 Oaks Industrial Estate Coventry Road Narborough Leicestershire LE0 5GF
LINCOLN (M40)	Unit 8 Stonefield Park Clifton Street Lincoln LN5 8AA
NEWCASTLE UNDER LYME (M12)	18-21 Croft Road Brampton Industrial Estate Newcastle under Lyme Staffordshire ST5 OTW
NUNEATON (M21)	19 Ptarmigan Place Townsend Drive Nuneaton CV11 6RX
REDDITCH (M20)	Heming Road Washford Redditch Worcestershire B98 ODH
TAMWORTH (M19)	Unit 3 Sterling Park Claymore Tamworth B77 5DO
WORCESTER (M73)	Unit 1 Northbrook Close Gregory Mill Ind Estate Worcester WR3 8BP

## LONDON & EAST ANGLIA

CHELMSFORD (M47)	Hanbury Road Widford Ind Estate Chelmsford Essex CM12 3AE
COLINDALE (M53)	Unit 14 Capital park Capital Way Colindale London NW9 OEQ
ENFIELD (M49)	284 Alma Road Enfield London EN3 7BB
GRAVESEND (M57)	Unit B4, Imperial Business Estate Gravesend Kent DA11 ODL
HARPENDEN (M46)	Unit 4 Riverside Estate Coldharbour Lane Harpenden AL5 4UN
LETCHWORTH (M50)	16-17 Woodside Ind Est. Works Road Letchworth Herts SG6 1LA
LONDON (M76)	2/4 Royal Lane Yiewsley West Drayton Middlesex UB7 8DL
MAIDENHEAD (M60)	Reform Road Maidenhead Berkshire SL6 8BY
MOLESEY (M61)	10 Island Farm Avenue West Molesey Surrey KT8 2UZ
NEWBURY (M24)	PO Box 5627 Newbury Berkshire RG14 5GF
IPSWICH (M48)	Unit 2B Elton Park Business Centre Hadleigh Road Ipswich IP2 ODD
NORWICH (M52)	2b Trafalgar Street Norwich NR1 3HN
SUNBURY (M63)	Unit 1a The Summit Hanworth Road Hanworth Ind Estate Sunbury on Thames TW16 5D
SYDENHAM (M62)	Unit 6 Metro Centre Kangley Bridge Road Sydenham SE26

## SOUTH EAST

ASHFORD (M58)	Unit 2 Bridge Road Business Estate Bridge Road Ashford Kent TN2 1BB
FLEET (M59)	Unit 1 Redfields Industrial Estate Church Crookham Fleet Hampshire GU13 ORD
HAYWARDS HEAT (M55)	21-25 Bridge Road Haywards Heath Sussex RH16 1UA
TONBRIDGE (M56)	Unit 30 Deacon Trading Estate Morley Road Tonbridge Kent TN9 1RA

## SOUTH WEST

BARNSTAPLE (M30)	P.O. Box 12 Barnstaple North Devon EX31 2YB
BOURNEMOUTH (M26)	63-65 Curzon Road Bournemouth Dorset BH1 4PW
BRIDGEWATER (M35)	6 Hamp Industrial Estate Bridgewater Somerset TA6 3NT
BRISTOL (M25)	11 Eldon Way Eldonwall Trading Bristol Avon BS4 3QQ
EMSWORTH (M33)	266 Main Road Southbourne Emsworth PO10 8JL
ISLE OF WIGHT (M34)	Unit 8 Enterprise Court Ryde Business Park Ryde Isle of Wight PO33 1DB
NEWTON ABBOT (M29)	Unit 2 Zealley Industrial Estate Kingsteignton Newton Abbot S. Devon TQ12 3TD
PLYMOUTH (M32)	16 Faraday Mill Cattedown Plymouth PL4 OST
REDRUTH (M36)	Unit 7D Pool Industrial Estate Wilson Way, Redruth, Cornwall TR15 3QW

# Installation instructions

 **Any electrical work required to install this appliance should be carried out by a qualified electrician or competent person.**

 **Any plumbing work required to install this appliance should be carried out by a qualified plumber or competent person.**

## Technical specifications

DIMENSIONS	Width Height Max depth Max depth with open door	59.6 cm 81.8 - 87.8 cm 57.5 cm 111.4 cm
ELECTRICAL CONNECTION MOTOR RATING DURING WASH POWER OF HEATING ELEMENT OVERALL POWER	Voltage	220/240 V - 50 Hz 200 W 2570 W 2770 W
WATER SUPPLY PRESSURE	Minimum Maximum	50 kPa (0.5 bar) 800 kPa (8 bar)
CAPACITY (STANDARD IEC) PLACE SETTINGS		12
CONSUMPTION	Water Electricity	29 l 1.6 kW/h

**Remove all packaging before positioning the machine.**

If possible, position the machine next to a water tap and a drain.

## Water supply connections

This dishwasher must be plumbed into a cold water supply.

The water pressure must be within the limits given in the technical specifications.

Your local Water Authority will advise you on the average mains pressure in your area.

The dishwasher features fill and drain hoses which can be turned either to the left or the right to suit the installation.

**The locknut must be correctly fitted to avoid water leaks.**

Avoid bends or kinks in the hose which could prevent or slow down the water supply.

If the machine is connected to new pipes or pipes which have not been used for a long time, you should run the water for a few minutes before connecting the inlet hose. This will prevent deposits of sand or rust clogging the inlet hose filter.

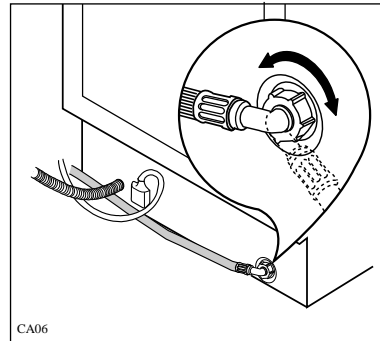

# Water outlet hose connection

The end of the drain hose can be connected in the following ways:

- A-** To the sink outlet siphon, securing it if necessary with a clip.
- B-** To a wall outlet provided with a vent-hole, minimum internal diameter 4 cm.

The waste connection must be at a height of between 30 cm (minimum) and 100 cm (maximum) from the floor. It makes no difference which way the drain hose faces, either to the right or left of the dishwasher.

Ensure the hose is not bent or squashed as this could prevent or slow down the discharge of water.

- C-** If you use a drain hose extension it must be no longer than 2 metres and its internal diameter must be no smaller than the diameter of the hose provided.

Likewise the internal diameter of the couplings used for connections to the waste outlet must be no smaller than the diameter of the hose provided.

**The sink plug must not be in place when the machine is draining as this could cause the water to siphon back into the machine.**

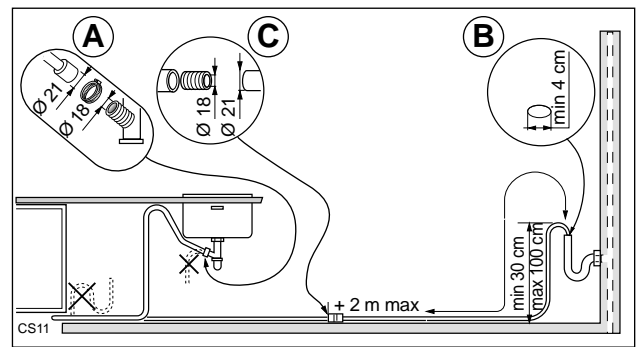



# Electrical connection



**This appliance must be earthed.**

**The manufacturer declines any responsibility should this safety measures not be observed.**

If the plug that is fitted to your appliance is not suitable for the socket, it must be cut off and the appropriate plug fitted.

## **Important**

The wires on the mains lead are coloured in accordance with the following code:

<b>Green and Yellow</b>	<b>-Earth</b>
<b>Blue</b>	<b>-Neutral</b>
<b>Brown</b>	<b>-Live</b>

If you fit your own plug, the colours of the wires in the mains lead of your appliance may not correspond with the markings identifying the terminals in your plug.

## **Proceed as follows:**

- 1.** Connect the Green and Yellow (earth) wire to the terminal in the plug which is marked with the letter "E" or the earth symbol or coloured green and yellow.
- 2.** Connect the Blue (neutral) wire to the terminal in the plug which is marked with the letter "N" or coloured black.
- 3.** Connect the Brown (live) wire to the terminal in the plug which is marked with the letter "L" or coloured red.

The plug moulded onto the lead incorporates a 13amp BSI362 fuse. Only ASTA or BSI fuses should be used.

The plug must not be used if the fuse cover/carrier is lost. The cover/carrier is indicated by the coloured insert at the base of the product.

A replacement cover/carrier must be obtained from your local Electrolux Service Force Centre.

## **This appliance complies with the following E.E.C. Directives:**

**- 73/23 or 19.2.73 (Low Voltage Directive) and subsequent modifications;**

**- 89/336 or 3.5.89 (Electromagnetic Compatibility Directive) and subsequent modifications.**

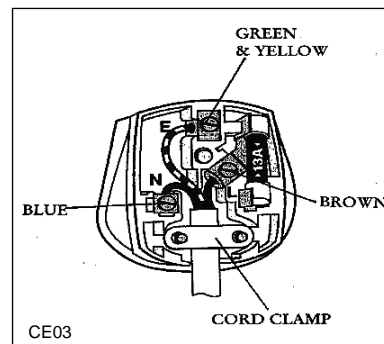



# The furniture door

The door on this appliance is designed for the overlay or a panel having the following dimensions:

- Width: 596 mm
- Height: 604 mm max
- Thickness: 20 mm max
- Weight: 2 - 7.5 kg max

The panel height should be no more than indicated, otherwise complete opening of the door will no longer be possible as the panel hits against the dishwasher plinth.

Furthermore, it is possible to line up the control panel to correspond with the height of the drawers of the adjacent pieces of furniture, thus perfectly co-ordinating with style of the rest of the unit furniture in your kitchen.

Add one or more of the fillets provided until you reach the desired height.

Secure the fillets as shown in the picture, by means of two screws 4 x 40 provided therewith.

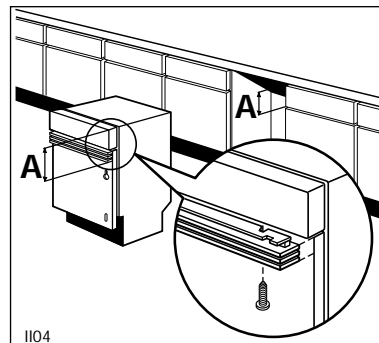

## Prepare the panel as follows:

Measure the distance (B) between the part below the control panel (or fillets) and the reference notch (X) on the door.

Measure the same distance (B) on the wooden panel starting from the upper edge.

At this distance position the supporting cross-bar provided, in correspondence with the reference (Z).

Keep the same distance between the centre of the support's fastening holes and the lateral edges of the wooden panel.

On the panel sign the seats for the four fastening screws. Drill the panel with a  $\varnothing 2 \times 12$  bit and fix the supporting cross-bar onto the wooden panel with the 3.5 x 16 screws provided.

Mount the decor panel by inserting the two pivots of the cross-bar into the slotted holes of the door.

Lift the decor panel until the perfect alignment with the fascia panel is obtained.

Once the correct position has been found, open the door and fasten the decor panel on the lower section by means of the two 4 x 40 screws provided, using the holes through the inner door.

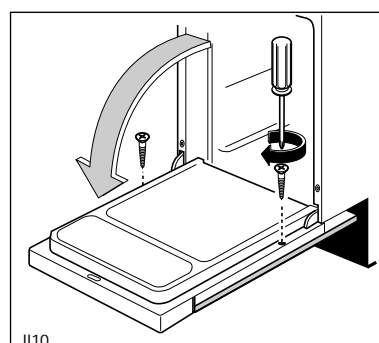
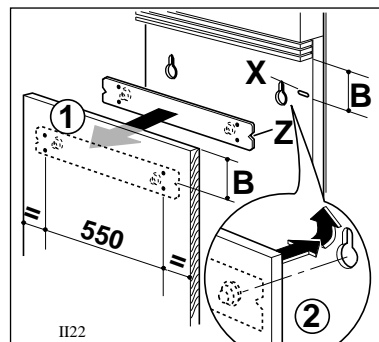

# Adjusting the door balance

The door of the dishwasher is balanced when it is open in any position.

Fitting the decor panel may sometimes affect this balance. In this case it will be necessary to adjust the balance as follows:

Half-open the door and regulate the screws located on the kick plate.

By screwing or unscrewing these screws, the tension of the door balancing springs is increased or decreased respectively.

The weight of the panel should be within the limits given in "The furniture door" otherwise balancing the door will not be possible.

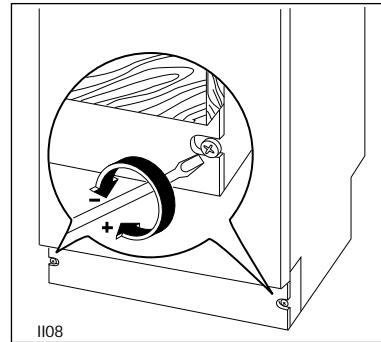

# Securing under a counter

Open the door; vertically insert the two mounting brackets (A) on the front part of the dishwasher and turn them 90° (see figure). Secure the brackets to the counter by means of two 3.5 x 16 screws provided.

**Important: the dishwasher must be secured against tilting. Therefore, make sure that the counter it is fitted under, is suitably secured to a fixed structure (adjacent kitchen cabinets, wall).**

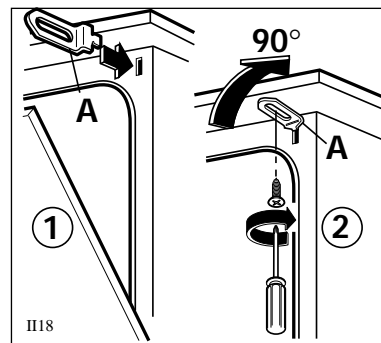

# Kitchen plinth adjustment

To allow correct opening of the door it is sometimes necessary to cut the kitchen plinth. Refer to the cutting table.

According to dimensions (a) and (b) as shown on the figure, you will find on the following table the depth (x) of the cut to be made on the plinth.

The dimensions (a) and (b) of the table are those most frequently used in the kitchen furnitures.

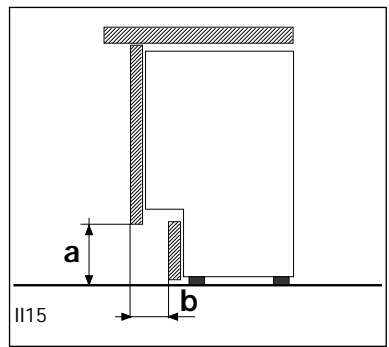
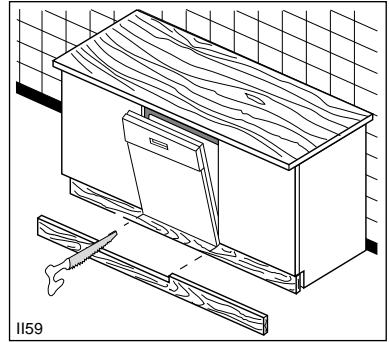

		Height (a)*								
		170	160	150	140	130	120	110	100	
Depth (b)*	40	136	131	125	118	110	100	93	85	X
	50	135	131	125	118	110	102	92	85	
	60	137	132	125	118	110	102	94	85	
	70	138	134	128	120	110	104	95	85	
	80	/	139	130	124	115	105	98	88	
	90	/	/	138	129	120	110	100	90	
	100	/	/	/	135	125	115	105	95	

(\*) dimensions in mm

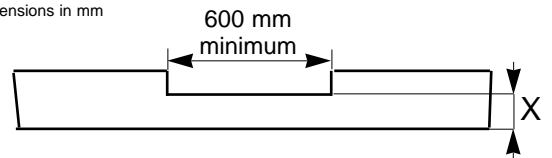

Dimensions of the cut on the plinth





