

Use & Care Guide

Built-In Dishwasher

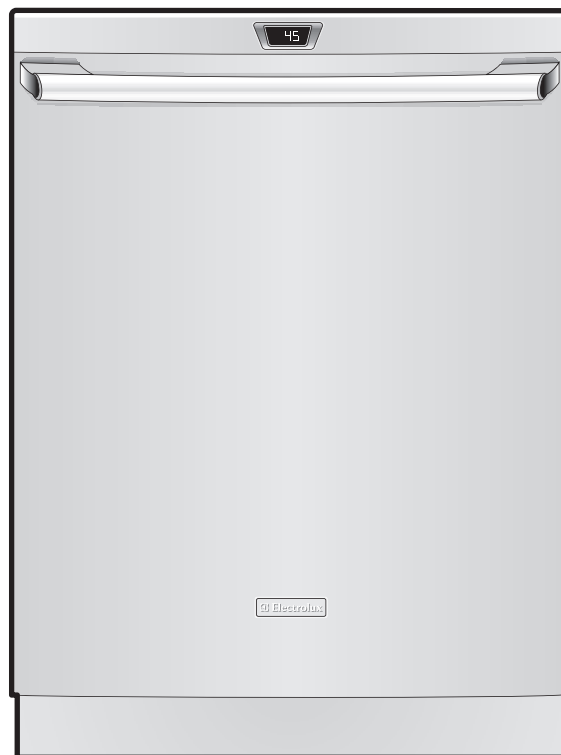

 **Electrolux**

Table of Contents

Finding Information	2
Make a Record for Future use	2
Questions?	2
Internet	2
Table of Contents	2
Safety	3
Important Safety Instructions	3
Feature Overview	4
How your Dishwasher Cleans	4
Operating Instructions	5
Getting Started	5
Normal Operating Sounds	5
Wash Cycle Selections	6
Cycle Selections	6
Energy Option Selections	7
Operation Selections	7
Status Window	8
Preparing & Loading Dishes	9
Dish Preparation	9
Loading the Top Rack	9
Loading the Bottom Rack	10
Adjusting Rack Height	10
Loading the Silverware Basket	11
Adding a dish	11
Dishwasher Dispenser & Detergents	12
Filling the Detergent Dispenser	12
How much Detergent to use	12
Detergent Usage Guide	13
Rinse Aid	14
Factors Affecting Performance	15
Water Pressure	15
Water Temperature	15
Care & Cleaning	16
Outside	16
Inside	16
Winterizing	17
Solutions to Common Problems	18
Food Soils Left on Dishes	18
Dishes Not Dry	19
Glassware/Flatware Spotted or Cloudy	18
Dishware Chipped	18
Dishware Stained or Discolored	19
Etching	19
Detergent Left in Cups	19
Dishwasher Leaks	20
Normal Sounds You Will Hear	20
Water in Bottom of Tub	20
Dishwasher Won't Run	20
Dishwasher Does Not Drain Properly	20
Cycle Takes a Long Time	21

Dishwasher Won't Fill	21
Dishwasher Has an Odor	21
Removing Spots and Film	21

Warranty Information	22
-----------------------------------	-----------

Spanish Version	23
------------------------------	-----------

French Version	40
-----------------------------	-----------

Please read and save this guide

Thank you for choosing **Electrolux**, the new premium brand in home appliances. This *Use & Care Guide* is part of our commitment to customer satisfaction and product quality throughout the service life of your new appliance.

We view your purchase as the beginning of a relationship. To ensure our ability to continue serving you, please use this page to record important product information.

Keep a record for quick reference

Purchase date

Electrolux model number

Electrolux serial number

NOTE

Registering your product with Electrolux enhances our ability to serve you. You can register online at www.electroluxappliances.com or by dropping your Product Registration Card in the mail.

Questions?

For toll-free telephone support in the U.S. and Canada:

1-877-4ELECTROLUX (1-877-435-3287)

For online support and Internet production information visit [http://](http://www.electroluxappliances.com)

www.electroluxappliances.com

Important Safety Instructions

Please read all safety instructions before using your new Electrolux dishwasher.

- Read all instructions before using your dishwasher.
- Use your dishwasher only as instructed in this Use and Care Manual.
- This manual does not cover every possible condition and situation that may occur. Use common sense and caution when installing, operating and maintaining any appliance.
- National Sanitation Foundation (NSF) certified residential dishwashers are not intended for licensed food establishments. Such establishments require a higher dishwasher water temperature to meet commercial sanitization requirements.
- **DISHWASHER MUST BE ELECTRICALLY GROUNDED.** Read the Installation Instructions for details.
- This dishwasher is designed to operate on regular house current (120 V, 60 Hz). Use a circuit equipped with a 15 ampere fuse or circuit breaker. Use a 20 ampere fuse or circuit breaker if dishwasher is connected with a food waste disposer.
- Do not operate dishwasher unless all enclosure panels are in their proper place as explained in the Installation Instructions provided with your dishwasher.
- To avoid entrapment and/or suffocation, remove the door to the washing compartment when removing an old dishwasher from service or discarding it.
- Keep young children and infants a safe distance away from the dishwasher when it is in operation.
- Use only detergents and rinse agents recommended for use in a dishwasher.
- Do not abuse, sit on, or stand on the door or dish rack of the dishwasher.
- Store dishwasher detergent and rinse agents out of the reach of children.

WARNING

This symbol will help alert you to such dangers as personal injury, burns, fire, and electrical shock.

WARNING

To reduce the risk of fire, electrical shock, or injury when using your dishwasher, follow basic precautions including the following:

- Do not wash plastic items unless marked “dishwasher safe” or the equivalent. Check with manufacturer for recommendations, if not marked. Items that are not dishwasher safe may melt.
- If the dishwasher drains into a food disposal, make sure disposal is completely empty before running dishwasher.
- Disconnect electrical power to dishwasher before servicing.
- Repairs should be done by a qualified Electrolux professional.
- Do not tamper with controls.
- Use care unloading the dishware when the SANITIZE option has been selected. Contents may be hot to the touch immediately after the end of cycle.
- When loading and unloading items:
 - Locate sharp items and knives so that they are not likely to damage the tub or door seal
 - Load sharp items and knives with the handles up to reduce the risk of cut-type injuries. Alternatively, place sharp items and knives in the utensil shelf located in the upper rack.
- Under certain conditions, hydrogen gas may be produced in a hot water system that has not been used for 2 weeks or more. **HYDROGEN GAS IS EXPLOSIVE.** If hot water system has not been used for such a period, before using dishwasher, turn on all hot water faucets and let water flow from each for several minutes. This will release any accumulated hydrogen gas. **HYDROGEN GAS IS FLAMMABLE.** Do not smoke or use an open flame during this time.
- Do not store or use combustible materials, gasoline or other flammable vapors and liquids in the vicinity of this or any other appliance.

NOTE

Save these important safety instructions for future reference.

Feature Overview

HOW YOUR DISHWASHER CLEANS

Your dishwasher cleans by spraying a mixture of hot water and detergent through the spray arms against soiled surfaces.

The dishwasher fills with water covering the filter area. Water is then pumped through the filter and spray arms. Soil particles go down the drain as the water is pumped out and replaced with clean water. The number of water fills will vary with the cycle being used.

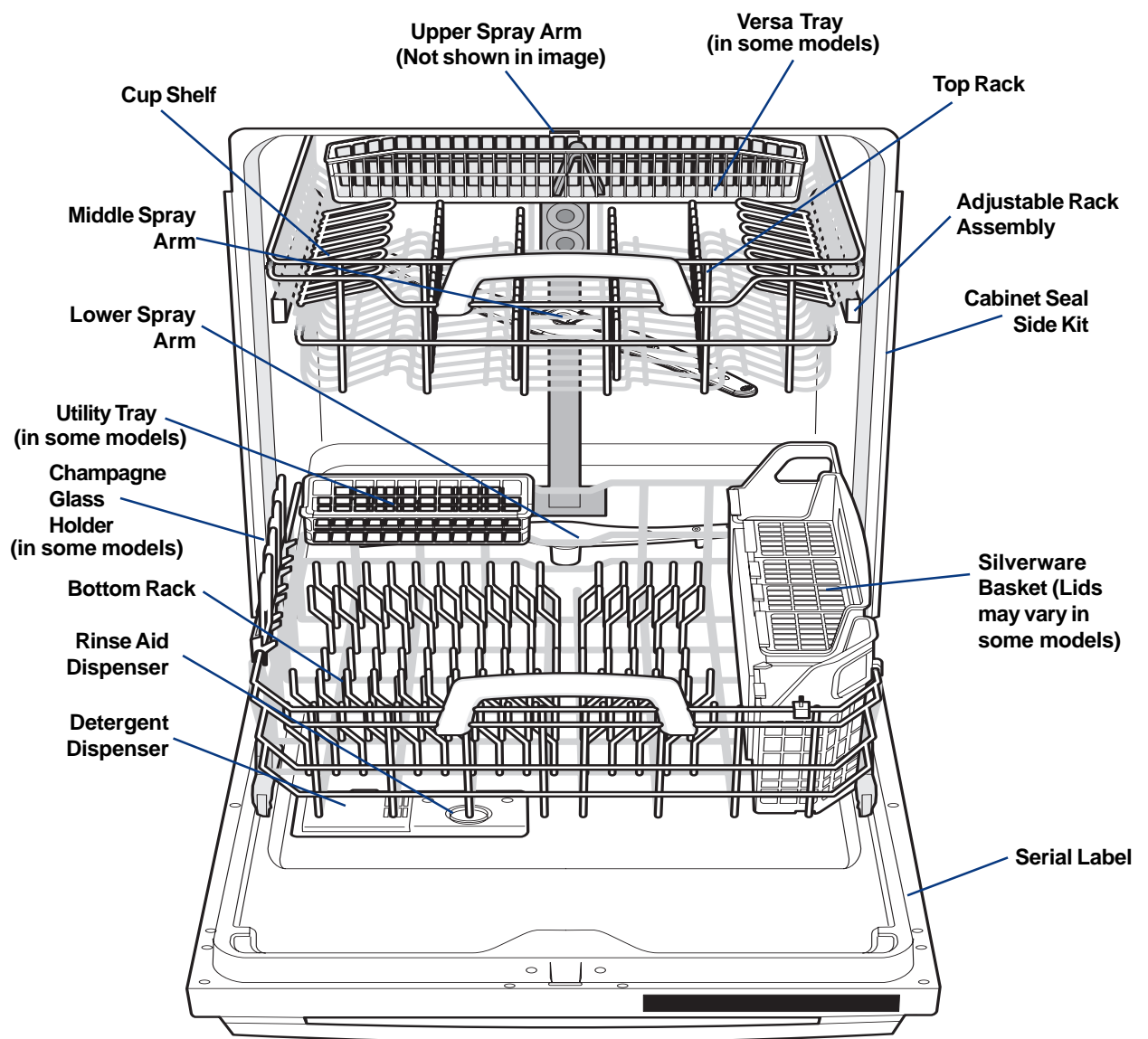

GETTING STARTED

EIDW6305



EIDW6105

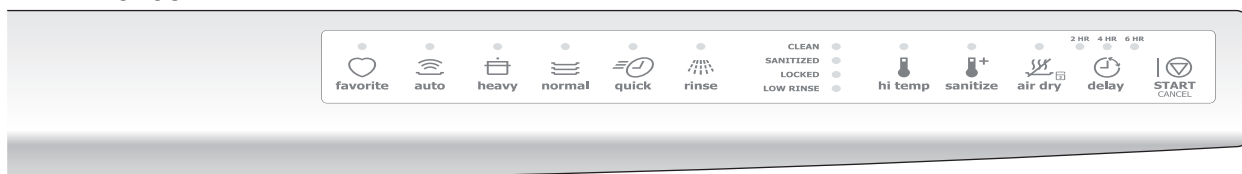

Press and hold HI-TEMP icon for 5 seconds before first use.

To run your dishwasher, follow these basic steps:

- 1 Load dishwasher. (See Preparing and Loading Dishes, pages 9-11.)
- 2 Add detergent. (See Dishwasher Dispenser & Detergents, pages 12-14.)
- 3 Add rinse aid, if needed. (See Rinse Aid, page 14.)
- 4 Select desired CYCLE. (See Cycle Selections, pages 6 -7.)
The Symbols are illuminated when selected.
- 5 Select desired OPTIONS. (See Energy Options Selections, page 7.)
The light surrounding the pad will glow when selected.
- 6 To start, press START/CANCEL pad and close door. (See Start/Cancel, page 8.)

NORMAL OPERATING SOUNDS

Your dishwasher uses energy efficient motors for the wash and drain portions of the cycle you select. Each cycle has a series of water fills and drains for washing and rinsing dishes. As each cycle begins, you may or may not hear the drain motor. You may also hear the splashing water as it enters the tub and the spray arms as they rotate and circulate water. The wash motor often pulsates throughout the cycle, which varies water pressure and optimizes performance.

WASH CYCLE SELECTIONS

Cycle times are approximate and vary by options selected. Hot water is necessary to activate dishwasher detergent and melt fatty food soils.

An automatic sensor checks the water temperature for the main wash of each cycle. When HI-TEMP WASH is selected, the sensor checks for an even higher temperature. Run hot water faucet nearest dishwasher until water is hot before starting.

CYCLE SELECTIONS

The Smart Sensor checks the soil level on your dishes in the Auto, Normal and Eco cycles. Cycle time and water usage will vary based on the amount of soil on the dishes. Cycle time will also vary based on the options selected and the incoming water temperature.

My Favorite



This cycle allows you to program your preferred cycle and options into one button. To program the Favorite Cycle: press and hold the Favorite key for 3 seconds. As the Favorite key starts to blink; select the cycles and options (Favorite key will remain blinking). Press start to save the Favorite cycles and options that you have chosen. The Favorite key remains solid which indicates the settings are saved. All the settings that were chosen are illuminated. Once programmed, simply press the Favorite key followed by Start/Cancel to have your programmed Favorite Cycle begin.

Heavy Wash



For pots, pans, casserole dishes and dinnerware with dried-on or baked-on soils. Water usage is approximately 9.5 gallons. Wash time ranges from approximately 130 to 149 mins.

Auto Wash



The dishwasher's Smart Sensor technology will determine the type of cycle required to clean the dishes and will clean more efficiently every time. When a partial load of lightly soiled dishes is placed in the unit, a wash cycle similar to a short wash will automatically be performed. When a full load of heavily soiled dishes is placed in the unit, a heavy wash cycle will automatically be performed. Water usage ranges from approximately 5.5 to 10.8 gallons. Wash time ranges from approximately 99 to 162 mins.

Normal Wash



For regularly soiled dishes and silverware. Water usage ranges from approximately 4.4 to 9.5 gallons. Wash time ranges from approximately 91 to 144 mins.

Eco Wash



For lightly soiled and pre-rinsed dishes and silverware. Water usage ranges from approximately 5.7 to 6.8 gallons. Wash time ranges from approximately 78 to 80 mins.

Quick Wash



For lightly soiled and pre-rinsed dishes and silverware. Water usage is approximately 6.9 gallons. Wash time is approximately 45 mins.

Stemware



For lightly soiled China and Crystal. Water usage is approximately 6.8 gallons. Wash time ranges from approximately 85 to 92 mins.



Rinse

For rinsing dishes that will be washed later. Water usage is approximately 2.8 gallons. Cycle time is approximately 20 minutes.

ENERGY OPTION SELECTIONS

Hi-Temp Wash



When HI-TEMP option is selected, the dishwasher heats water in the main wash to approximately 140°F (60°C). HI-TEMP ON will be displayed.

This increase in water temperature helps dishwasher detergent remove food, grease and soil from dishes more effectively and aids in drying. HI-TEMP option can only be used with AUTO, HEAVY and NORMAL cycles.

When HI-TEMP option is selected, the icon will light up and remain on until the door is closed.

Child Lock Controls/ Air Dry



To prevent children from accidentally changing the dishwasher cycle or starting the dishwasher, lock the dishwasher controls by pressing and releasing the AIR DRY icon for 3 seconds. An indicator light on the lock graphic pad will illuminate when the controls are locked and no new selections can be made until the lock is released. To unlock the controls, press the AIR DRY icon until the indicator light goes out. If child lock is activated the dishwasher will not work.

Sanitize



To sanitize your dishes and glassware, select the SANITIZE option. SANITIZE ON will be displayed when selected, the light surrounding the icon will turn red until the START key is pressed or the door is closed. This option heats the water temperature in the final rinse to 157°F (69.4°C) and maintains that temperature for 7 minutes. SANITIZE is available in Auto, Heavy, and Normal cycles. Only these sanitization cycles have been designed to meet NSF requirements.

The cycle time will be extended until the proper water temperature is reached. Washing action will continue during the water heating delay. For best results, the incoming water temperature should be at least 120°F (49°C).

If the SANITIZE option is selected, SANITIZED will be displayed at the end of the cycle. The sanitization criteria may not be satisfied if there is an interruption of the cycle, a power failure occurs, or if the incoming water temperature is below 120°F (49°C). Sanitize will not display at the end of the cycle if the NSF requirements for sanitization are not reached.

OPERATION SELECTIONS

Delay Start



The Delay Start option allows you to automatically delay starting your dishwasher from 1 to 24 hours on EIDW6305 and 2-4-6 on EIDW6105 models.

Press the DELAY START key until the desired delay time shows in the STATUS window on the EIDW6305. Press the DELAY START key until the desired delay time LED is lit on EIDW6105. Display will indicate the delay start time and will countdown until cycle starts.

To cancel the DELAY START option and begin the cycle before the delay period is over, press the START/CANCEL pad.

STATUS WINDOW



AVAILABLE ON EIDW6305

The STATUS window displays codes typically seen during normal operation or programming of the dishwasher. The STATUS window indicates the following activity:

- 1-24** Indicates number of delay start hours for selected cycle.
- CL** Flashes once the program has been entered and the START/CANCEL key is pressed. It also flashes if the door is opened during a wash cycle. Close the dishwasher door to begin or continue a wash cycle.
- hd** Flashes to indicate a water heat delay. Time remaining is displayed in the center of the status window when a cycle is being ran.
- WASHING** WASHING will be illuminated in the upper left corner.
- CLEAN** CLEAN will illuminate on the left side of the display after a cycle is ran and the dishes are clean.
- SANITIZED** SANITIZED will illuminate on the left side of the display after the cycle. If SANITIZE option was selected.

Start/Cancel



To start a cycle, press the START/CANCEL key once and close the door. To cancel when a cycle is running, open the door and press the START/CANCEL key once. Close the door again and the dishwasher will drain and shut off.

NOTE

Opening the door during normal operation will only pause the selected cycle.

Error Indications

In certain situations which are critical to the machine function and safe operation, the control shall shut down and indicate an error code 'Er' (See Error Codes on page 21). *On units without a display, all indicator lights will flash.*

If one of these codes are displayed contact the Electrolux Customer Care Center at **1-877-435-3287**. They will be able to provide assistance in troubleshooting the problem and/or locating an authorized service technician, if needed.

DISH PREPARATION

Scrape away large pieces of food, bone, pits, toothpicks, etc. The wash system will remove remaining food particles. Gently scrape away burned-on food with a non-scratch utensil or let dish soak before washing (See Figure 1). Empty liquids from glasses and cups.

Foods containing vegetable oil and/or chemical additives such as mustard, mayonnaise, vinegar, lemon juice or tomato-based products may cause discoloration of stainless steel and plastics if allowed to sit for a long period of time. Unless the dishwasher is to be operated at once, it is best to rinse off these food soils.

- Load racks so that large items do not prevent the detergent dispenser from opening.
- Check manufacturer's recommendations before washing items in question.
- If the dishwasher drains into a food disposal, **be sure disposal is completely empty before starting dishwasher.**

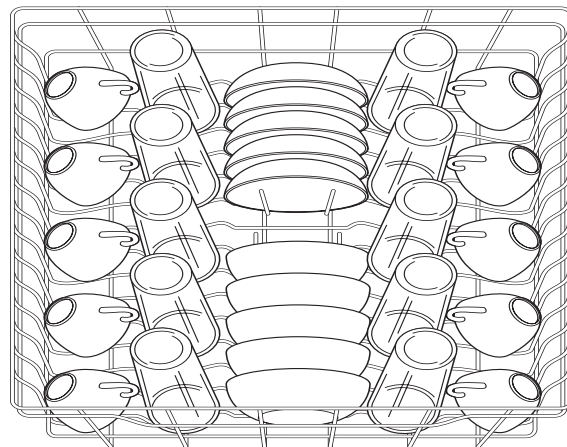

Figure 1

LOADING THE TOP RACK

The top rack is designed for flexibility in loading a wide variety of items including cups, glasses, stemware, small plates, bowls, etc.

- Load glasses in top rack. Damage may occur if placed in bottom rack unless Stemware Cycle is selected.
- Load items with open ends facing down for better cleaning and draining.
- Damage may occur if delicate items touch each other during dishwasher operation.
- Long-handled knives and utensils can be placed in the top rack's versa tray.
- Be sure nothing protrudes through the bottom of the rack to block rotation of middle spray arm.



10 place settings standard loading pattern

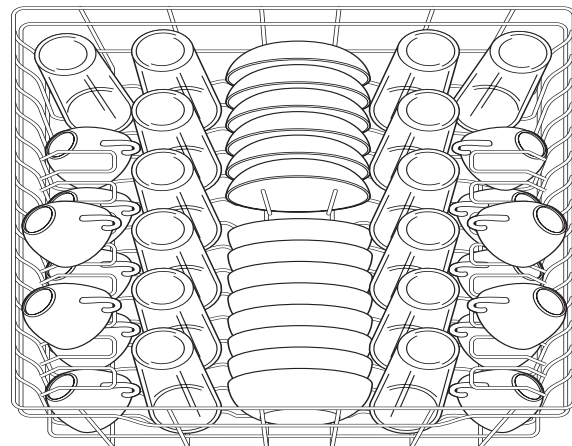

14 place settings standard loading pattern

NOTE

Features in your dishwasher's model may vary in appearance from illustrations in this manual.

LOADING THE BOTTOM RACK

Our adjusted rack space allows you to put items up to 15" in the bottom rack.

The bottom rack is designed for plates, saucers, bowls, and cookware.

- Large items should be placed along the edge so they do not block the middle spray arm rotation.
- For best results, place bowls, casserole dishes, and sauce pans with soiled surface facing down or toward the center. Tilt slightly for better drainage.
- Make sure tall items do not block middle spray arm rotation.
- Be sure pan handles do not protrude through the bottom of the rack and block the lower spray arm rotation.

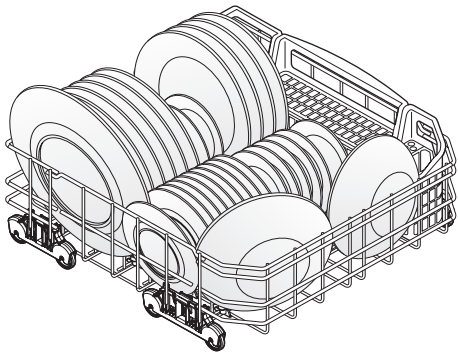

10 place settings standard loading pattern

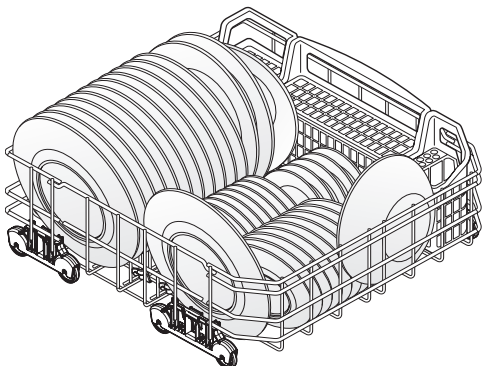

14 place settings standard loading pattern

Fold-down Tines

The fold-down tines in the lower rack and upper rack make easy loading for those extra large and hard-to-fit items. The tines may be left up for normal use or folded down for more flexible loading.

Fold tines down for ease in loading large pots or pans.

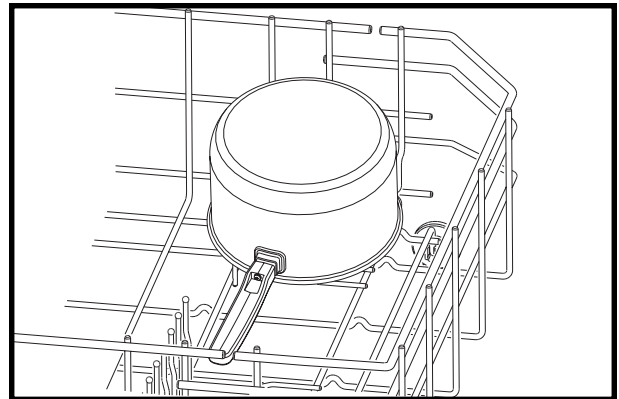

ADJUSTING RACK HEIGHT

The top rack height can be easily adjusted to accommodate loading taller dishes in either rack. **Height should be adjusted without dishes in the racks.**

To accommodate taller dishes in the bottom rack, there are 3 positions available:

To raise the rack to the middle or upper position, simply lift the rack. The lever is spring loaded to engage the middle or upper position. To lower the rack to the middle or lower position, push the lever with your thumbs and pushing downward simultaneously. Releasing the lever will allow the middle position to be engaged. To ensure ease of adjustment when adjusting the rack, ensure that the rack remains level from front to back with both sides at the same height.

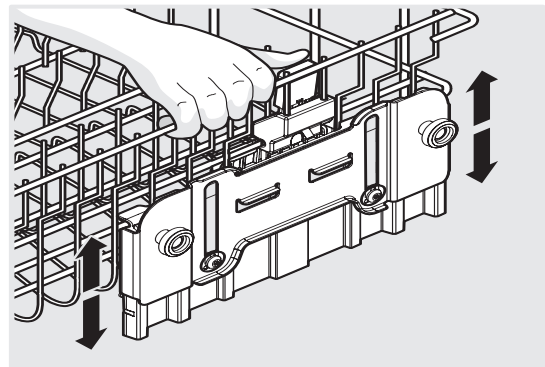

LOADING THE SILVERWARE BASKET

Load the silverware basket while it is in the bottom rack or take the basket out for loading on a counter or table.

- Place small items like baby bottle caps, jar lids, corn cob holders, etc., in a covered section. Close the cover to hold small items in place.
- Be sure nothing protrudes through bottom of basket or rack to block the lower spray arm.
- Do not mix silver and stainless items to avoid damaging the silver finish.

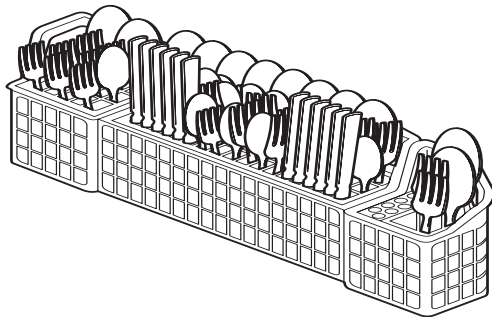

VersaTray

The versa tray can be used in the upper rack to hold spatulas, large spoons and other large utensils.

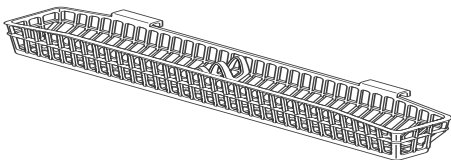

CAUTION

TO AVOID CUT INJURY: Load sharp items (knives, skewers, etc.) pointing down. Failure to do so may result in injury.

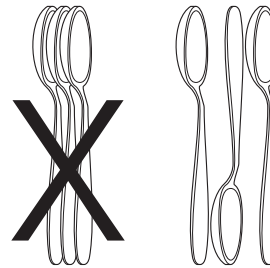

When covers are up, mix non-sharp items in each section of the basket with some pointing up and some down to avoid nesting. Water spray cannot reach nested items.

ADDING A DISH

To add or remove items after wash cycle starts:

- 1 Open door slightly and wait a few seconds until wash action stops before completely opening.
- 2 Add the item.
- 3 Close door firmly to latch and cycle will automatically resume.

CAUTION

TO AVOID BURN INJURY: Slightly open door and wait until spray arms and wash action stop. Hot water may splash out of dishwasher. Failure to do so may result in injury.

FILLING THE DETERGENT DISPENSER

The detergent dispenser has one main wash and one pre-wash cup. The covered cups open automatically to release detergent.

- Use only automatic dishwashing detergent. Other detergents will cause oversudsing.
- When using automatic dishwashing detergent tabs, place one tab in main wash cup and close.
- Add detergent just before starting cycle.
- Store detergent in a cool, dry location. Moist or caked detergent will not dissolve properly.

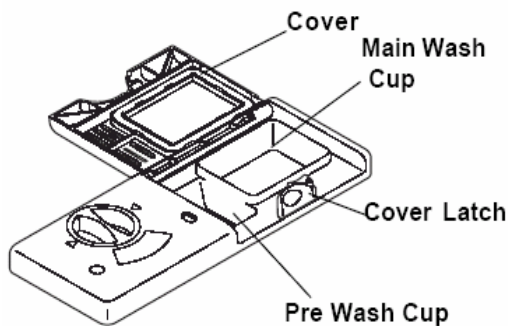

HOW MUCH DETERGENT TO USE

The amount of detergent to use depends on the water hardness. *Water hardness is measured in grains per gallon (gpg).* “Hard water” contains large amounts of harsh minerals in granulated form, above 10-11 grains per gallon (gpg), which can affect water quality.

Using too little detergent can result in poor cleaning and hard water filming or spotting. Using too much detergent in soft water can cause a permanent film called “etching.” (See Etching, page 19.)

Your local water company, water softener company or county extension agent can tell you the water hardness in your area.

CAUTION

The use of industrial grade detergent can damage parts of the dishwasher leading to damage to the unit and surrounding property. Use only household grade automatic dishwasher detergents.

DETERGENT USAGE GUIDE

Refer to the following table for recommended detergent usage.

Cycle	Soft Water (0-3 Grains)	Medium Hard Water (4-8 Grains)	Hard Water (9-12 Grains)	Very Hard Water* (Over 12 Grains)
Heavy, Auto or Normal	2 Teaspoons (Main Wash Cup – ¼ Full)	5 Teaspoons (Main Wash Cup – fill to line above “Regular”)	8 Teaspoons (Main Wash Cup Completely Full)	Each Cup – Completely Full (Water Softener Recommended)
Quick, Eco, Delicate, Stemware	2 Teaspoons (Main Wash Cup – ¼ Full)	5 Teaspoons (Main Wash Cup – fill to line above “Regular”)	8 Teaspoons (Main Wash Cup completely full)	Main Wash Cup – Completely Full (Water Softener Recommended)
Rinse	No Detergent	No Detergent	No Detergent	No Detergent (Water Softener Recommended)

As shown in the last column of this table, a water softener is recommended to improve water quality and dishwashing performance when using very hard water.

Other suggestions:

- Try adding more detergent at the beginning of the main wash portion of the cycle.
- As a rule, use 1 teaspoon for each grain above 12. Unlatch the door, open slowly and add detergent to the bottom of the tub.
- Close the door to latch and the dishwasher will continue through the cycle.

RINSE AID

Rinse aid greatly improves drying and reduces water spots and filming. It causes the water to “sheet” off of dishes rather than form water droplets that cling and leave spots.

The rinse aid dispenser, located next to the detergent cup, automatically releases a measured amount of rinse aid during the last rinse. If spotting and poor drying are problems, increase the amount of rinse aid dispensed by rotating the dial to a higher number. The dial is located under the dispenser cap.

If the rinse aid is low, LOW RINSE displays at the beginning and end of the cycle on the EIDW6305 model. If the rinse aid is low, the LOW RINSE LED is illuminated at the beginning and end of the cycle on the EIDW6105 model indicating that it is time to refill.

To add liquid rinse aid:

- 1 Turn dispenser cap 1/4 turn counterclockwise and lift out.
- 2 Pour in rinse aid until liquid reaches the flat surface marked MAX in the Rinse Aid dispenser. Do not overfill since this can cause oversudsing.
- 3 Replace cap.
- 4 Wipe up any spills with a damp cloth.

The dispenser holds enough for 35 to 140 washes, depending on setting.

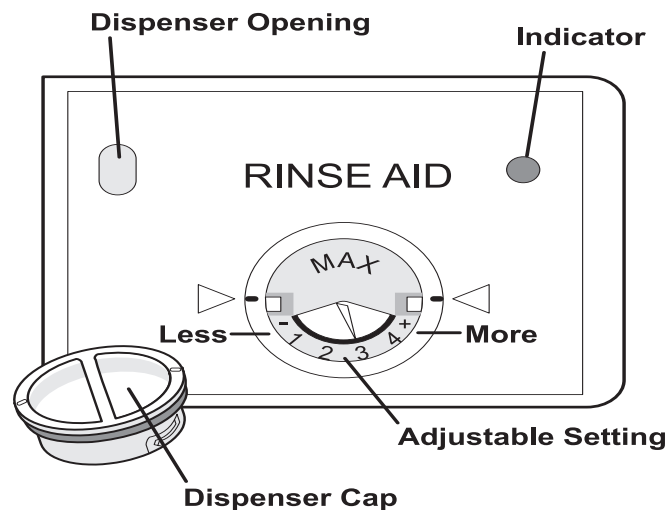

WATER TEMPERATURE

Hot water is needed for best dishwashing and drying results. Water entering the dishwasher should be at least 120°F (49°C) to give satisfactory results.

To check water temperature entering the dishwasher:

- 1 Turn on hot water faucet nearest dishwasher for several minutes to clear cool water from pipes.
- 2 Hold a candy or meat thermometer in stream of water to check the temperature.
- 3 If temperature is below 120°F (49°C), have a qualified person raise the water heater thermostat setting.

WATER PRESSURE

The hot water line to the dishwasher must provide water pressure between 20 and 90 pounds per square inch (psi).

Low water pressure may occur when laundry or showers are in operation. Wait until water use is reduced before starting dishwasher.

IMPORTANT

Before starting a cycle, run hot water to clear cool water from pipe.

OUTSIDE

Occasionally wipe the outside surfaces of your dishwasher with a mild nonabrasive detergent and water. Rinse and dry.

Stainless Steel Door

Clean the stainless steel door and handle with hot, soapy water and a dishcloth. Rinse with clean water and a cloth. Do not use harsh scrubbing cleaners. Use only kitchen cleaners made especially for cleaning stainless steel.

INSIDE

Remove spots on the door and tub with a damp, nonabrasive cloth.

→ IMPORTANT

Read before operating your dishwasher!

Care of Glass Trap Filter

Your dishwasher is equipped with a state of the art wash system. Periodically, the Glass Trap Filter and Large Food Particle Trap may need to be cleaned to maximize wash performance.

The Glass Trap Filter is located in the center of the Large Food Particle Trap. The Glass Trap Filter is designed to collect pieces of broken glass, straws, bones and pits. To remove items in the Glass Trap Filter, grasp the handle, lift out, empty and replace.

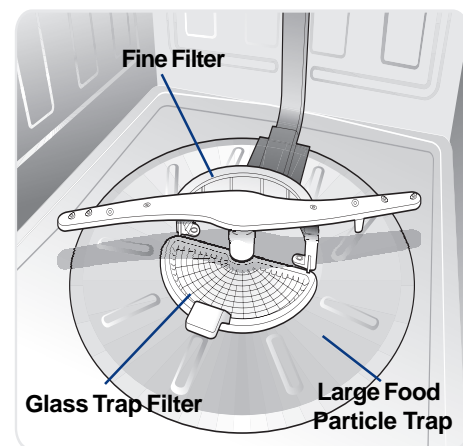

Care of Drain Air Gap

If a drain air gap was installed for your built-in dishwasher, check to make sure it is clean so the dishwasher will drain properly. A drain air gap is usually mounted on the sink at the countertop and can be inspected by removing the cover. This is not part of your dishwasher and is not covered by warranty.

CAUTION

Freezing temperatures may cause water lines to rupture. Be sure all supply lines to and circulating lines within dishwasher are protected. Failure to do so could result in property damage.

WINTERIZING

A dishwasher left in an unheated place should be protected from freezing. Have a qualified person do the following:

To Disconnect Service:

- 1 Turn off electrical power to the dishwasher at the supply source by removing fuses or tripping circuit breaker.
- 2 Shut off water supply.
- 3 Place a pan under the inlet valve. Disconnect water line from inlet valve and drain into pan.
- 4 Disconnect drain line and drain water into pan.

To Restore Service:

- 1 Reconnect the water, drain, and electrical power supply.
- 2 Turn on water and electrical power supply.
- 3 Fill both detergent cups and run dishwasher through a HEAVY WASH cycle.

NOTE

See Installation Instructions for more details.

 **IMPORTANT**

Before calling for service, review this list. It may save you both time and expense. This list includes common experiences that are not the result of defective workmanship or material in your dishwasher.

 **FOOD SOILS LEFT ON DISHES**

- Check incoming water temperature. (See Getting Started, page 5.) It should be at least 120°F (49°C). (See Factors Affecting Performance, page 15.)
- Choose another cycle for longer washing time.
- Check rack loading section for proper loading—avoid nesting items.
- Home water pressure may be too low—should be 20 to 90 pounds per square inch (psi).
- Check water hardness. For extremely hard water, it may be necessary to install a water softener. (See Detergent Usage Guide, page 13.)
- Use fresh detergent.
- Make sure items are not blocking any of the spray arms, preventing them from rotating.

DISPLAY NOT IN OPERATING MODE

- Hold down HI-TEMP ICON for 5 seconds to reset unit to Normal Operating Mode.

DISHES NOT DRY

- Make sure the rinse aid dispenser is filled.
- Increase the amount of rinse aid (See Rinse Aid, page 14).
- Check the incoming water temperature. Be sure it is at least 120°F (49°C).
- Check for proper loading—avoid nesting items.
- Plastic items may need to be towel dried. More water collects on plastic items when cycle is complete because they do not get as hot as glass or metal items.
- Cups with a concave bottom will collect water.

DISHWARE CHIPPED

- Load with care and do not overload. (See Preparing and Loading Dishes, pages 9-11.)
- Place delicate items in top rack.
- Place glasses securely against pins and not over pins.
- Load items so they are secure and don't jar loose when moving racks in and out. Move racks in and out slowly.
- Make sure tall glasses and stemware will clear top of tub when rack is pushed in.
- It is recommended to wash fine antique china and crystal by hand.

GLASSWARE / FLATWARE SPOTTED OR CLOUDY

- Check water hardness. For extremely hard water, it may be necessary to install a water softener. (See Detergent Usage Guide, page 13.)
- Water temperature may be low. Avoid extremely low or high temperatures. (See Factors Affecting Performance, page 15.)
- Avoid overloading and improper loading. (See Preparing and Loading Dishes, pages 9-11.)
- Use fresh detergent. Old detergent is ineffective.
- Make sure rinse aid dispenser is filled.
- Check to see that proper amount of detergent is being used for cycle selected. (See Detergent Dispenser, pages 12-14.)
- Home water pressure may be too low—it should be 20 to 90 pounds per square inch (psi).

ETCHING

- Using too much detergent in soft or softened water causes this film that cannot be removed.
- Adjust the amount of detergent based on the water hardness. (Check Detergent Usage Guide, page 13.)
- Lower the water temperature.

DISHWARE STAINED OR DISCOLORED

- Tea and coffee can stain cups. Remove the stains by hand washing in a solution of 1/2 cup (120 ml) bleach and one quart (1 L) of warm water. Rinse thoroughly.
- Iron deposits in water can cause a yellow or brown film. A water filter installed in-line with your water supply will correct this problem.
- Aluminum utensils can leave gray/black marks when they rub against other items. Load properly.
- Certain high acid foods can cause discoloration of stainless steel and plastics if allowed to sit for a long period. Use the Rinse cycle or rinse by hand if not operating dishwasher at once.
- Mixing stainless steel and silver utensils in silverware basket can cause pitting on the stainless steel utensils. Avoid mixing stainless steel and silver.

DETERGENT LEFT IN DISPENSER CUP

- Detergent may be old. Discard and use fresh detergent.
- Be sure water action can reach the dispenser.
- Check to see if cycle has been completed.
- Make sure items do not prevent the detergent dispenser from opening.
- Make sure the upper rack is firmly engaged to the nozzle on the back of the tub before closing the door.

DISHWASHER LEAKS

- Use only fresh detergent designed for automatic dishwashers. Measure detergent carefully. Try a different brand.
- Spilled rinse aid can cause foam and lead to overflowing. Wipe up any spills with a damp cloth.
- Check to see that dishwasher is level (See Installation Instructions).

NORMAL SOUNDS YOU WILL HEAR

- Normal sounds include water fill, water circulation and motor sounds.
- Pump pulsing will cause motor speed to increase and decrease at regular intervals during cycles.

WATER IN THE BOTTOM OF THE TUB

- It is not normal for water to remain in the bottom of the tub at the end of a cycle. If water remains in the bottom of the tub at the end of a cycle, the dishwasher may not be draining properly. (See Dishwasher Does Not Drain Properly, page 21.) The filter may also need to be cleaned. (See Care of Filter, page 16.) *Note: It is normal to see a small amount of water under the filter at the end of a cycle.*

DISHWASHER WON'T RUN

- Check to see if circuit breaker is tripped or if a fuse is blown.
- Make sure water supply is turned on.
- Check to see if cycle is set correctly. (See Operating Instructions, pages 5-8.)
- Check to see if the Delay Start option has been selected.
- Make sure door is closed and latched.
- Check to see if the dishwasher is in the Child Lock mode.

DISHWASHER DOES NOT DRAIN PROPERLY

- If unit is hooked up to a garbage disposal, make sure the disposer is empty.
- If unit is hooked up to a new food waste disposer, check to see if the “knockout” plug located inside the disposal inlet has been removed.
- Check to see if drain hose is kinked.
- Make sure cycle is complete, not in a pause.

CYCLE TAKES A LONG TIME

- Check to see if cycle is in a water heating delay.
- Check to see if the delay start option has been selected.
- Check to see if the sanitize option has been selected.

DISHWASHER WON'T FILL

- Check to see if the water supply is turned on.
- Add 1/2 cup of water to the bottom of the unit and start again.off.

DISHWASHER HAS AN ODOR

- Soiled dishes left in dishwasher too long can create an odor. Use Rinse cycle.
- There will be a “new” smell when first installed. This is normal.
- Check to see if unit is draining properly (See Dishwasher Does Not Drain Properly, page 21).

REMOVING SPOTS AND FILM

Hard water can cause lime deposit buildup on the interior of the dishwasher. Dishes and glasses may also get spots and film for a number of reasons (See Glassware/Flatware Spotted or Cloudy, page 19).

To remove build-up, spots and film, clean using the following instructions:

- 1 Load clean dishes and glasses in normal manner. Do not load any metal utensils or silverware.
- 2 Do not add detergent.
- 3 Select the NORMAL WASH cycle. Press START/CANCEL pad and close door.
- 4 Allow dishwasher to run until it begins the second fill. Open door and pour 2 cups of white vinegar into the bottom of dishwasher.
- 5 Close and latch door and allow cycle to finish.

NOTE

If these conditions persist, a home water softener should be considered.

ERROR CODES

In certain situations which are critical to machine function and safe operation. Error codes will be shown in the status window on the EIDW6305.

- Er 01
Leak Detector - When water is detected under the tub.
- Er 02
Thermistor - When thermistor/turbidity module fails
- Er 03
Wash Pump - Wash pump not operating
- Er 04
Drying Damper - Drying damper not operating
- Er 05
Upper Fan - When in the dry cycle, the control board does not receive proper speed feedback from the upper fan
- Er 06
Lower Fan - When in the dry cycle, the control board does not receive proper speed feedback from the lower fan
- Er 07
Drain Valve - When in the drain mode, the control board does not receive proper position feedback from the drain valve
- Er 08
Tactile or touch switch - Control board has verified a switch on the user interface is bad or shorted
- Er 09
Communications - Communication failure between main user board and power supply
- Er 10
Mains Relay - Failure in the mains power relay
- Er 11
Drain Valve - Time out before finding a state for the drain valve
- Er 12
Drain Valve - The drain valve is running when it should be off
- Er 13
System wide - Lost control of the State Machine

Your appliance is covered by a one year limited warranty. For one year from your original date of purchase, Electrolux will repair or replace any parts of this appliance that prove to be defective in materials or workmanship when such appliance is installed, used, and maintained in accordance with the provided instructions. The stainless tub and door liner of your appliance are covered by a lifetime limited warranty. During the lifetime of the appliance, Electrolux will provide a replacement stainless tub or door liner that fails to contain water due to a defect in materials or workmanship if the appliance has been installed, used, and maintained in accordance with the provided instructions. In addition, the dishwasher racks and the electronic control module of your appliance are covered by a two through five year limited warranty. During the 2nd through 5th years from your original date of purchase, Electrolux will provide a replacement dishwasher rack or electronic control module for your appliance which has proven to be defective in materials or workmanship when such appliance is installed, used, and maintained in accordance with the provided instructions.

Exclusions

This warranty does not cover the following:

1. Products with original serial numbers that have been removed, altered or cannot be readily determined.
2. Product that has been transferred from its original owner to another party or removed outside the USA or Canada.
3. Rust on the interior or exterior of the unit.
4. Products purchased "as-is" are not covered by this warranty.
5. Food loss due to any refrigerator or freezer failures.
6. Products used in a commercial setting.
7. Service calls which do not involve malfunction or defects in materials or workmanship, or for appliances not in ordinary household use or used other than in accordance with the provided instructions.
8. Service calls to correct the installation of your appliance or to instruct you how to use your appliance.
9. Expenses for making the appliance accessible for servicing, such as removal of trim, cupboards, shelves, etc., which are not a part of the appliance when it is shipped from the factory.
10. Service calls to repair or replace appliance light bulbs, air filters, water filters, other consumables, or knobs, handles, or other cosmetic parts.
11. Labor or in-home service costs during the additional limited warranty periods beyond the first year from your original date of purchase.
12. Pickup and delivery costs; your appliance is designed to be repaired in the home.
13. Surcharges including, but not limited to, any after hour, weekend, or holiday service calls, tolls, ferry trip charges, or mileage expense for service calls to remote areas, including the state of Alaska.
14. Damages to the finish of appliance or home incurred during transportation or installation, including but not limited to floors, cabinets, walls, etc.
15. Damages caused by: services performed by unauthorized service companies; use of parts other than genuine Electrolux parts or parts obtained from persons other than authorized service companies; or external causes such as abuse, misuse, inadequate power supply, accidents, fires, or acts of God.

DISCLAIMER OF IMPLIED WARRANTIES; LIMITATION OF REMEDIES

CUSTOMER'S SOLE AND EXCLUSIVE REMEDY UNDER THIS LIMITED WARRANTY SHALL BE REPAIR OR REPLACEMENT AS PROVIDED HEREIN. **CLAIMS BASED ON IMPLIED WARRANTIES, INCLUDING WARRANTIES OF MERCHANTABILITY OR FITNESS FOR A PARTICULAR PURPOSE, ARE LIMITED TO ONE YEAR OR THE SHORTEST PERIOD ALLOWED BY LAW, BUT NOT LESS THAN ONE YEAR.** ELECTROLUX SHALL NOT BE LIABLE FOR CONSEQUENTIAL OR INCIDENTAL DAMAGES SUCH AS PROPERTY DAMAGE AND INCIDENTAL EXPENSES RESULTING FROM ANY BREACH OF THIS WRITTEN LIMITED WARRANTY OR ANY IMPLIED WARRANTY. SOME STATES AND PROVINCES DO NOT ALLOW THE EXCLUSION OR LIMITATION OF INCIDENTAL OR CONSEQUENTIAL DAMAGES, OR LIMITATIONS ON THE DURATION OF IMPLIED WARRANTIES, SO THESE LIMITATIONS OR EXCLUSIONS MAY NOT APPLY TO YOU. THIS WRITTEN WARRANTY GIVES YOU SPECIFIC LEGAL RIGHTS. YOU MAY ALSO HAVE OTHER RIGHTS THAT VARY FROM STATE TO STATE.

If You Need Service

Keep your receipt, delivery slip, or some other appropriate payment record to establish the warranty period should service be required. If service is performed, it is in your best interest to obtain and keep all receipts. Service under this warranty must be obtained by contacting Electrolux at the addresses or phone numbers below.

This warranty only applies in the USA, Puerto Rico and Canada. In the USA and Puerto Rico, your appliance is warranted by Electrolux Major Appliances North America, a division of Electrolux Home Products, Inc. In Canada, your appliance is warranted by Electrolux Canada Corp. Electrolux authorizes no person to change or add to any obligations under this warranty. Obligations for service and parts under this warranty must be performed by Electrolux or an authorized service company. Product features or specifications as described or illustrated are subject to change without notice.

USA
1-877-435-3287
Electrolux Major Appliances North America
P.O. Box 212378
Augusta, GA 30907

Canada
1-800-265-8352
Electrolux Canada Corp.
5855 Terry Fox Way
Mississauga, Ontario, Canada L5V 3E4