



Use & Care Guide

Built-In Dishwasher



 **Electrolux**

MAKE A RECORD FOR FUTURE USE

Brand Electrolux

Purchase Date _____

Model Number _____

Serial Number _____

NOTE

See the Features Overview on page 7 for the location of the serial label which lists your product's serial number.

QUESTIONS?

1-877-4Electrolux (United States and Canada)

INTERNET

For online support and product information, in the U.S. visit www.electroluxusa.com. In Canada, visit www.electroluxca.com.

4 Finding Information

TABLE OF CONTENTS

Finding Information	3	Solutions to Common Problems	23
Make a Record for Future use	3	Food Soils Left on Dishes	23
Questions?	3	Dishes Not Dry	23
Internet	3	Glassware/Flatware Spotted or Cloudy	24
Table of Contents	4	Dishware Chipped	24
Safety	5	Dishware Stained or Discolored	25
Important Safety Instructions	5	Etching	25
Feature Overview	7	Detergent Left in Cups	25
How your Dishwasher Cleans	7	Dishwasher Leaks	26
Operating Instructions	8	Normal Sounds You Will Hear	26
Getting Started	8	Water in Bottom of Tub	26
Normal Operating Sounds	8	Dishwasher Won't Run	26
Wash Cycle Selections	9	Dishwasher Does Not Drain Properly	27
Cycle Selections	9	Cycle Takes a Long Time	27
Energy Option Selections	10	Dishwasher Won't Fill	27
Operation Selections	11	Dishwasher Has an Odor	27
Status Window	12	Removing Spots and Film	28
Preparing & Loading Dishes	13	Warranty Information	29
Dish Preparation	13		
Loading the Top Rack	13		
Loading the Bottom Rack	14		
Adjusting Rack Height	15		
Loading the Silverware Basket	16		
Adding a dish	16		
Dishwasher Dispenser & Detergents	17		
Filling the Detergent Dispenser	17		
How much Detergent to use	17		
Detergent Usage Guide	18		
Rinse Aid	19		
Factors Affecting Performance	20		
Water Pressure	20		
Water Temperature	20		
Care & Cleaning	21		
Outside	21		
Inside	21		
Winterizing	22		

IMPORTANT SAFETY INSTRUCTIONS

Please read all safety instructions before using your new Electrolux dishwasher.

WARNING

To reduce the risk of fire, electrical shock, or injury when using your dishwasher, follow basic precautions including the following:

- Read all instructions before using your dishwasher.
- Use your dishwasher only as instructed in this Use and Care Manual.
- This manual does not cover every possible condition and situation that may occur. Use common sense and caution when installing, operating and maintaining any appliance.
- National Sanitation Foundation (NSF) certified residential dishwashers are not intended for licensed food establishments. Such establishments require a higher dishwasher water temperature to meet commercial sanitization requirements.
- **DISHWASHER MUST BE ELECTRICALLY GROUNDED.** Read the Installation Instructions for details.
- This dishwasher is designed to operate on regular house current (120 V, 60 Hz). Use a circuit equipped with a 15 ampere fuse or circuit breaker. Use a 20 ampere fuse if dishwasher is connected with a food waste disposer.
- Do not operate dishwasher unless all enclosure panels are in their proper place as explained in the Installation Instructions provided with your dishwasher.
- To avoid entrapment and/or suffocation, remove the door to the washing compartment when removing an old dishwasher from service or discarding it.
- Keep young children and infants a safe distance away from the dishwasher when it is in operation.
- Use only detergents and rinse agents recommended for use in a dishwasher.
- Do not abuse, sit on, or stand on the door or dish rack of the dishwasher.

6 Safety

- Store dishwasher detergent and rinse agents out of the reach of children.
- Do not wash plastic items unless marked “dishwasher safe” or the equivalent. Check with manufacturer for recommendations, if not marked. Items that are not dishwasher safe may melt and create a potential fire hazard.
- If the dishwasher drains into a food disposal, make sure disposal is completely empty before running dishwasher.
- Disconnect electrical power to dishwasher before servicing.
- Repairs should be done by a qualified Electrolux professional.
- Do not tamper with controls.
- Use care unloading the dishware when the SANITIZE option has been selected. Contents may be hot to the touch immediately after the end of cycle.
- When loading items to be washed:
 - Locate sharp items and knives so that they are not likely to damage the tub or door seal; and
 - Load sharp items and knives with the handles up to reduce the risk of cut-type injuries. Alternatively, place sharp items and knives in the utensil shelf located in the upper rack.
- Under certain conditions, hydrogen gas may be produced in a hot water system that has not been used for 2 weeks or more. **HYDROGEN GAS IS EXPLOSIVE.** If hot water system has not been used for such a period, before using dishwasher, turn on all hot water faucets and let water flow from each for several minutes. This will release any accumulated hydrogen gas. **HYDROGEN GAS IS FLAMMABLE.** Do not smoke or use an open flame during this time.
- Do not store or use combustible materials, gasoline or other flammable vapors and liquids in the vicinity of this or any other appliance.

NOTE

SAVE THESE IMPORTANT SAFETY INSTRUCTIONS FOR FUTURE REFERENCE.

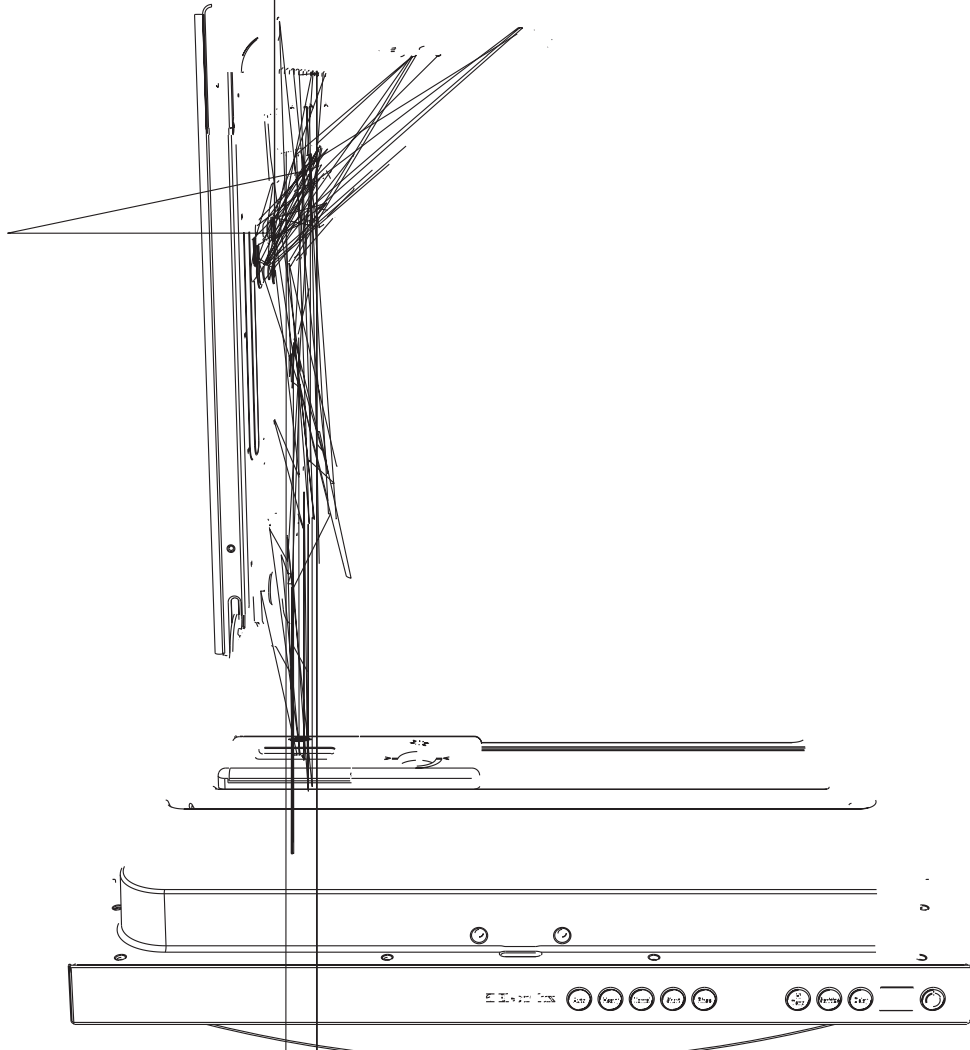

8 Operating Instructions

GETTING STARTED

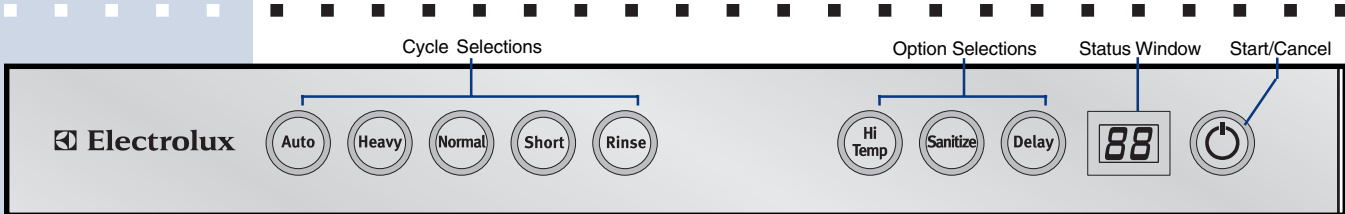

To run your dishwasher, follow these basic steps:

- 1 Load dishwasher. (See Preparing and Loading Dishes, pages 13-16.)
- 2 Add detergent. (See Dishwasher Dispenser & Detergents, pages 17-18.)
- 3 Add rinse aid, if needed. (See Rinse Aid, page 19.)
- 4 Select desired CYCLE. (See Cycle Selections, page 9.)
The light surrounding the pad glows when selected.

NOTE

The lights surrounding the pads will only glow when the door is open because the dishwasher is designed to have the controls hidden under the countertop.

- 5 Select desired OPTIONS. (See Energy Options Selections, page 10.)
The light surrounding the pad will glow when selected.
- 6 To start, press START/CANCEL pad and close door. (See Start/Cancel, page 11.)

NOTE

The dishwasher is programmed to remember your last cycle so you do not have to reset each time. To start the dishwasher using the same cycle and options selected on the previous wash, press the START/CANCEL pad.

NORMAL OPERATING SOUNDS

Your dishwasher uses energy efficient motors for the wash and drain portions of the cycle you select. Each cycle has a series of water fills and drains for washing and rinsing dishes. As each cycle begins, you may—or may not—hear the drain motor. You may also hear the splashing water as it enters the tub and the spray arms as they rotate and circulate water. The wash motor often pulsates throughout the cycle, which varies water pressure and optimizes performance.

WASH CYCLE SELECTIONS

Cycle times are approximate and vary by options selected. Hot water is necessary to activate dishwasher detergent and melt fatty food soils.

An automatic sensor checks the incoming water temperature for the main wash of each cycle, delaying the timer if necessary, until the water is hot enough. When HI-TEMP WASH is selected, the sensor checks for an even higher temperature.

CYCLE SELECTIONS

The Smart Sensor checks the soil level on your dishes in the Auto, Heavy, Normal and Short Wash cycles. Depending on soil level, the sensor will determine if additional water fills are needed to clean the dishes or if water fills can be deleted. Cycle time and water usage will vary based on the amount of soil on the dishes. Cycle time will also vary based on the options selected and the incoming water temperature.

Auto Wash

When a partial load of lightly soiled dishes is placed in the unit, a wash cycle similar to a short wash will automatically be performed. When a full load of heavily soiled dishes is placed in the unit, a heavy wash cycle will automatically be performed. The dishwasher's Smart Sensor technology will determine the type of cycle required to clean the dishes and will clean more efficiently every time. Water usage ranges from 3.7 to 7.3 gallons. Wash time ranges between 1.2 and 1.6 hours.

Heavy Wash

For pots, pans, casseroles and dinnerware with dried-on or baked-on soils. Water usage ranges from 6.1 to 7.3 gallons. Wash time ranges between 1.5 and 1.6 hours.

Normal Wash

For regularly soiled dishes and silverware. Water usage ranges from 4.9 to 7.3 gallons. Wash time ranges between 1.3 and 1.6 hours.

Short Wash

For lightly soiled and pre-rinsed dishes and silverware. Water usage ranges from 3.7 to 6.1 gallons. Wash time ranges between 1.2 and 1.5 hours.

Rinse

For rinsing dishes that will be washed later. Water usage is 2.4 gallons. Cycle time is approximately 20 minutes.

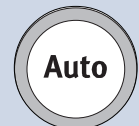

10 Operating Instructions

ENERGY OPTION SELECTIONS



Hi-Temp Wash

When HI-TEMP WASH option is selected, the dishwasher heats water in the main wash to approximately 140°F (60°C).

This increase in water temperature helps dishwasher detergent remove food, grease and soil from dishes more effectively and aids in drying. HI-TEMP WASH option can be used with all cycles except RINSE.

When HI-TEMP WASH option is selected, the light surrounding the pad will come on and remain on until end of cycle.

To turn off the HI-TEMP WASH option, press the pad a second time. The light surrounding the pad will turn off.



Sanitize

To sanitize your dishes and glassware, select the SANITIZE option. When selected, the light surrounding the pad will remain lit until the START/CANCEL pad is pressed or the door is closed. This option heats the water temperature in the final rinse to 155°F (68°C) and maintains that temperature for 9 minutes. SANITIZE is available in Auto Wash, Heavy Wash, Normal Wash and Short Wash cycles. Only these sanitization cycles have been designed to meet NSF requirements.

The cycle time will be extended until the proper water temperature is reached. Washing action will continue during the water heating delay. For best results, the incoming water temperature should be at least 120°F (49°C).

The light surrounding the pad will not illuminate at the end of the cycle if the NSF requirements for sanitization are not reached. The sanitization criteria may not be satisfied if there is an interruption of the cycle, a power failure occurs, or if the incoming water temperature is below 120°F (49°C).

To turn off the SANITIZE option, press the pad a second time. The light surrounding the pad will turn off.

OPERATION SELECTIONS

Delay Start

The DELAY START option allows you to automatically delay starting your dishwasher from 1 to 24 hours.

Press the DELAY START pad until the desired delay time shows in the STATUS window. A light will come on indicating the delay start hours and will remain on until cycle starts.

To cancel the DELAY START option and begin the cycle before the delay period is over, press the START/CANCEL pad.

Start/Cancel

To start a cycle, press the START/CANCEL pad once and close the door.

To cancel when a cycle is running, open the door and press the START/CANCEL pad once. Close the door again and the dishwasher will drain and shut off.

NOTE

Opening the door during normal operation will only pause the selected cycle.

Chime

Your dishwasher is equipped with a chime to audibly indicate when you have pressed a cycle or selected an option. The chime also signals the completion of the selected cycle. Press the SHORT and RINSE pads simultaneously to turn the chime on and off.

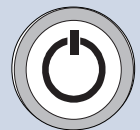

12 Operating Instructions

STATUS WINDOW

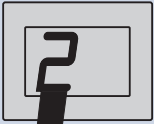

The STATUS window displays codes typically seen during normal operation or programming of the dishwasher. The window will not display anything when the door is closed. The STATUS window indicates the following activity:

- 1-24** Indicates number of delay start hours for selected cycle.
- CL** Flashes once the program has been entered and the START/CANCEL pad is pressed. It also flashes if the door is opened during a wash cycle. Close the dishwasher door to begin or continue a wash cycle.
- HO** Flashes to indicate a water heat delay.
- PF** Appears in window when dishwasher is first installed, or when power has been interrupted. HI-TEMP WASH, SANITIZE and START/CANCEL backlighting will also flash. To clear, touch START/CANCEL pad.
- CF** Appears in window when user must remove and clean filter. Once filter is cleaned and replaced, dishwasher will continue normal operation. (See Care and Cleaning, page 21.)
- On** Appears in window if chime is activated. Press the SHORT and RINSE pads simultaneously to activate chime.
- OF** Appears in window if chime is deactivated. Press the SHORT and RINSE pads simultaneously to deactivate chime.
- LO** Appears in window if rinse aid level is low. Add rinse aid. (See Rinse Aid, page 19.)

DISH PREPARATION

Scrape away large pieces of food, bone, pits, toothpicks, etc. The wash system will remove remaining food particles. Gently scrape away burned-on food with a non-scratch utensil or set dish soak before washing. Empty liquids from glasses and cups.

Foods containing vegetable oil and/or chemical additives such as mustard, mayonnaise, vinegar, lemon juice or tomato-based products may cause discoloration of stainless steel and plastics if allowed to sit for a long period of time. Unless the dishwasher is to be operated at once, it is best to rinse off these food soils.

- Load racks so that large items do not prevent the detergent dispenser from opening.
- Check manufacturer's recommendations before washing items in question.
- If the dishwasher drains into a food disposal, **be sure disposal is completely empty before starting dishwasher.**



LOADING THE TOP RACK

The top rack is designed for flexibility in loading a wide variety of items including cups, glasses, stemware, small plates, bowls, etc.

- Load glasses in top rack. Damage may occur if placed in bottom rack.
- Load items with open ends facing down for better cleaning and draining.
- Damage may occur if delicate items touch each other during dishwasher operation.
- Long-handled knives and utensils can be placed in the top rack's utensil shelf.
- Be sure nothing protrudes through the bottom of the rack to block rotation of middle spray arm.

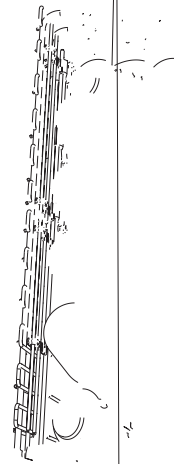

14 Preparing & Loading Dishes

Utensil Shelf

The utensil shelf can be used in the upper rack to hold spatulas, large spoons and other large utensils.

NOTE

Features in your dishwasher's model may vary in appearance from illustrations in this manual.

LOADING THE BOTTOM RACK

The bottom rack is designed for plates, saucers, bowls, and cookware.

- Large items should be placed along the edge so they do not block the middle spray arm rotation.
- For best results, place bowls, casseroles, and sauce pans with soiled surface facing down or toward the center. Tilt slightly for better drainage.
- Make sure tall items do not block middle spray arm rotation.
- Be sure pan handles do not protrude through the bottom of the rack and block the lower spray arm rotation.
- Additional utensils or cups may be placed on the rear cupshelves.

Fold-down Tines

The fold-down tines in the lower rack make easy loading for those extra large and hard-to-fit items. The tines may be left up for normal use or folded down for more flexible loading.

Fold tines down for ease in loading large pots or pans.

ADJUSTING RACK HEIGHT

The top rack height can be easily adjusted to accommodate loading taller dishes in either rack. Height can be adjusted with or without dishes in the racks.

To accommodate taller dishes in the bottom rack, raise the rack height as follows:

- 1 Lift top rack on each side, pulling toward the middle into the upper position. The self-guided adjusting mechanism will stop when the upper height position is reached.

The upper position provides nearly 2 inches of additional height for items in the bottom rack.

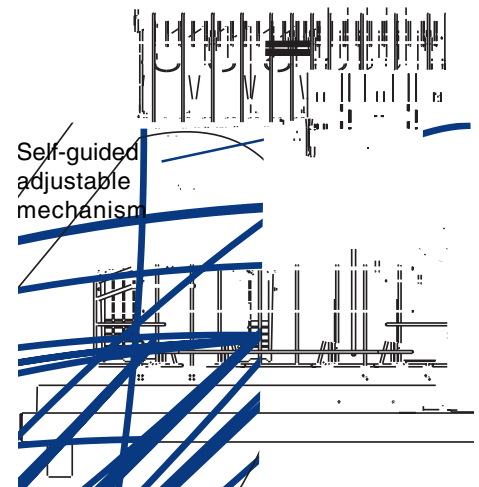

To accommodate taller dishes in the top rack, lower the top rack height as follows:

- 1 Lift rack on each side, pulling toward the middle, until it lifts slightly.
- 2 Gently lower the rack into the lower position. The self-guided adjusting mechanism will stop when the lower height position is reached.

This position provides nearly 2 inches of additional height for items in the top rack.

16 Preparing & Loading Dishes

LOADING THE SILVERWARE BASKET

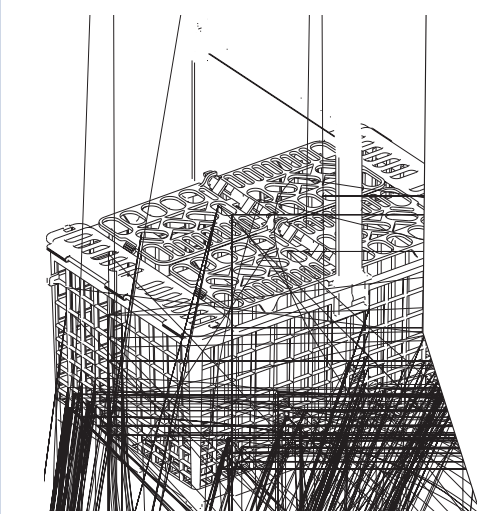

Load the silverware basket while it is in the bottom rack or take the basket out for loading on a counter or table.

- Place small items like baby bottle caps, jar lids, corn cob holders, etc., in a covered section. Close the cover to hold small items in place.
- Be sure nothing protrudes through bottom of basket or rack to block the lower spray arm.
- Do not mix silver and stainless items to avoid damaging the silver finish.

CAUTION

TO AVOID CUT INJURY: Load sharp items (knives, skewers, etc.) pointing down. Failure to do so may result in injury.



When covers are up, mix non-sharp items in each section of the basket with some pointing up and some down to avoid nesting. Water spray cannot reach nested items.

ADDING A DISH

To add or remove items after wash cycle starts:

- 1 Open door slightly and wait a few seconds until wash action stops before completely opening.
- 2 Add the item.
- 3 Close door firmly to latch and cycle will automatically resume.

CAUTION

TO AVOID BURN INJURY: Slightly open door and wait until spray arms and wash action stop. Hot water may splash out of dishwasher. Failure to do so may result in injury.

FILLING THE DETERGENT DISPENSER

The detergent dispenser has two covered cups. Fill one cup for small loads. Fill both cups for larger loads. Close cover and add detergent to the indented section in the cover for a prewash. Detergent in the prewash section of the cover falls into the dishwasher when the door is closed. The covered cups open automatically to release detergent.

- Use only automatic dishwashing detergent. Other detergents will cause oversudsing.
- When using automatic dishwashing detergent tabs, place one tab in main wash cups and close.
- Add detergent just before starting cycle.
- Store detergent in a cool, dry location. Moist or caked detergent will not dissolve properly.

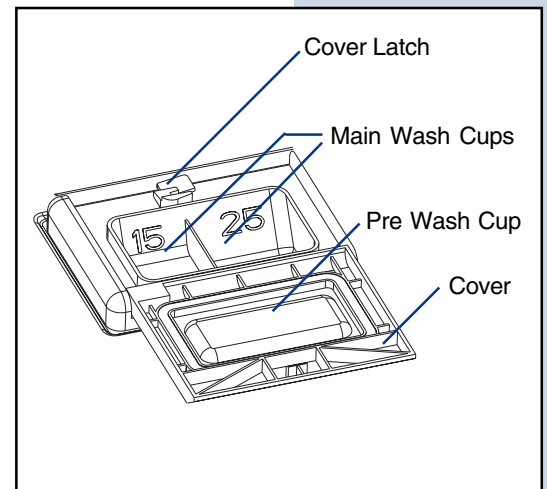

HOW MUCH DETERGENT TO USE

The amount of detergent to use depends on the water hardness. *Water hardness is measured in grains per gallon (gpg).* “Hard water” contains large amounts of harsh minerals in granulated form, above 10-11 grains per gallon (gpg), which can affect water quality.

Using too little detergent can result in poor cleaning and hard water filiming or spotting. Using too much detergent in soft water can cause a permanent film called “etching.” (See Etching, page 25.)

Your local water company, water softener company or county extension agent can tell you the water hardness in your area.

18 Dishwasher Dispenser & Detergents

DETERGENT USAGE GUIDE

Refer to the following table for recommended detergent usage.

Cycle	Soft Water (0-3 Grains)	Medium Hard Water (4-8 Grains)	Hard Water (9-12 Grains)	Very Hard Water* (Over 12 Grains)
Heavy Wash or Normal Wash	2 Teaspoons (Main Wash Cup – ¼ Full)	5 Teaspoons (Main Wash Cup – fill to line above “Regular”)	8 Teaspoons (Main Wash Cup Completely Full)	Each Cup – Completely Full (Water Softener Recommended)
Short Wash	2 Teaspoons (Main Wash Cup – ¼ Full)	5 Teaspoons (Main Wash Cup – fill to line above “Regular”)	8 Teaspoons (Main Wash Cup completely full)	Main Wash Cup – Completely Full (Water Softener Recommended)
Rinse	No Detergent	No Detergent	No Detergent	No Detergent (Water Softener Recommended)

As shown in the last column of this table, a water softener is recommended to improve water quality and dishwashing performance when using very hard water.

Other suggestions:

- Try adding more detergent at the beginning of the main wash portion of the cycle.
- As a rule, use 1 teaspoon for each grain above 12. Unlatch the door, open slowly and add detergent to the bottom of the tub.
- Close the door to latch and the dishwasher will continue through the cycle.

RINSE AID

Rinse aid greatly improves drying and reduces water spots and filming. It causes the water to “sheet” off of dishes rather than form water droplets that cling and leave spots.

The rinse aid dispenser, located next to the detergent cup, automatically releases a measured amount of rinse aid during the last rinse. If spotting and poor drying are problems, increase the amount of rinse aid dispensed by rotating the dial to a higher number. The dial is located under the dispenser cap.

The indicator turns dark when full and clear when it is time to refill.

On models with a STATUS window, LO displays at the end of the cycle, indicating that it is time to refill.

To add liquid rinse aid:

- 1 Turn dispenser cap 1/4 turn counterclockwise and lift out.
- 2 Pour in rinse aid until liquid touches the indicated fill level. Do not overfill since this can cause oversudsing.
- 3 Replace cap.
- 4 Wipe up any spills with a damp cloth.

The dispenser holds enough for 35 to 140 washes, depending on setting.

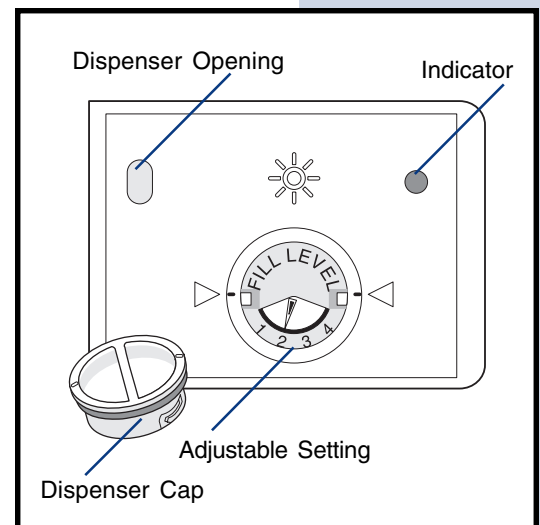

20 Factors Affecting Performance

WATER PRESSURE

The hot water line to dishwasher must provide water pressure between 20 and 120 pounds per square inch (psi).

Low water pressure may occur when laundry or showers are in operation. Wait until water use is reduced before starting dishwasher.

WATER TEMPERATURE

Hot water is needed for best dishwashing and drying results. Water entering the dishwasher should be at least 120°F (49°C) to give satisfactory results.

To check water temperature entering the dishwasher:

- 1 Turn on hot water faucet nearest dishwasher for several minutes to clear cool water from pipes.
- 2 Hold a candy or meat thermometer in stream of water to check the temperature.
- 3 If temperature is below 120°F (49°C), have a qualified person raise the water heater thermostat setting.

IMPORTANT

Before starting a cycle, run hot water to clear cool water from pipe.

OUTSIDE

Occasionally wipe the outside surfaces of your dishwasher with a mild nonabrasive detergent and water. Rinse and dry.

Stainless Steel Door

Clean the stainless steel door and handle with hot, soapy water and a dishcloth. Rinse with clean water and a cloth. Do not use harsh scrubbing cleaners. Use only kitchen cleaners made especially for cleaning stainless steel.

INSIDE

Remove spots on the door and tub with a damp, nonabrasive cloth. If needed, clean around the tub gasket area with a damp cloth.

IMPORTANT

Read before operating your dishwasher!

Care of Filter

Your dishwasher is equipped with a state of the art wash system. The invisible direct feed wash system delivers water using pulse wash technology resulting in a quiet, more efficient wash.

Periodically, the filter and food particle trap assembly may need to be cleaned to maximize wash performance. Your dishwasher may indicate this need by flashing "CF" in the display window. Remove, clean and replace filter and food particle trap assembly as instructed below.

To Clean Filter:

- 1 Clear the filter and food particle trap assembly of all debris.
- 2 Remove the food particle trap assembly by rotating the handle 90° in a counterclockwise direction and clean with water and mild soap.
- 3 Lift filter to remove being careful to prevent any food from falling into drain pump area. Clean with water and mild soap.
- 4 Replace filter and food particle trap assembly.
- 5 Rotate and lightly pull the food particle trap assembly 90° in a clockwise direction to ensure the assembly locks in place.

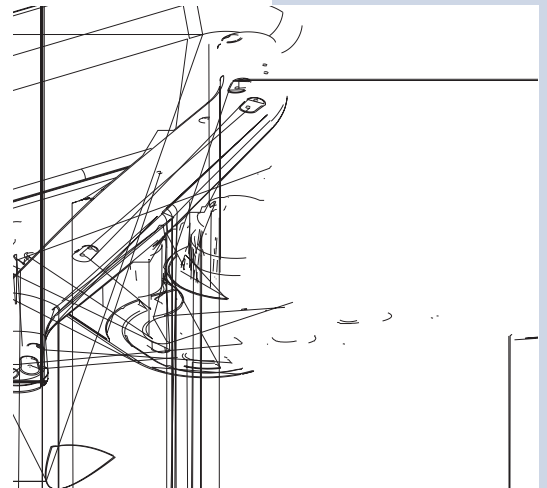

22 Care & Cleaning

Care of Drain Air Gap

If a drain air gap was installed for your built-in dishwasher, check to make sure it is clean so the dishwasher will drain properly. A drain air gap is usually mounted on the sink at the countertop and can be inspected by removing the cover. This is not part of your dishwasher and is not covered by warranty.

CAUTION

Freezing temperatures may cause water lines to rupture. Be sure all supply lines to and circulating lines within dishwasher are protected. Failure to do so could result in property damage.

WINTERIZING

A dishwasher left in an unheated place should be protected from freezing. Have a qualified person do the following:

To Disconnect Service:

- 1 Turn off electrical power to the dishwasher at the supply source by removing fuses or tripping circuit breaker.
- 2 Shut off water supply.
- 3 Place a pan under the inlet valve. Disconnect water line from inlet valve and drain into pan.
- 4 Disconnect drain line from pump and drain water into pan.

NOTE

See Installation Instructions for more details.

To Restore Service:

- 1 Reconnect the water, drain, and electrical power supply.
- 2 Turn on water and electrical power supply.
- 3 Fill both detergent cups and run dishwasher through a HEAVY WASH cycle.

NOTE

See Installation Instructions for more details.

IMPORTANT

Before calling for service, review this list. It may save you both time and expense. This list includes common experiences that are not the result of defective workmanship or material in your dishwasher.

FOOD SOILS LEFT ON DISHES

- Check incoming water temperature. (See Getting Started, page 8.) It should be at least 120°F (49°C). (See Factors Affecting Performance, page 20.)
- Choose another cycle for longer washing time.
- Check rack loading section for proper loading—avoid nesting items.
- Home water pressure may be too low—should be 20 to 120 pounds per square inch (psi).
- Check water hardness. For extremely hard water, it may be necessary to install a water softener. (See Detergent Usage Guide, page 18.)
- Use fresh detergent.
- Make sure items are not blocking any of the spray arms, preventing them from rotating.

DISHES NOT DRY

- Make sure the rinse aid dispenser is filled.
- Increase the amount of rinse aid (See Rinse Aid, page 19).
- Check the incoming water temperature. Be sure it is at least 120°F (49°C).
- Check for proper loading—avoid nesting items.
- Plastic items may need to be towel dried. More water collects on plastic items when cycle is complete because they do not get as hot as glass or metal items.
- Cups with a concave bottom will collect water.

24 Solutions to Common Problems

GLASSWARE/FLATWARE SPOTTED OR CLOUDY

- Check water hardness. For extremely hard water, it may be necessary to install a water softener. (See Detergent Usage Guide, page 18.)
- Water temperature may be low. Avoid extremely low or high temperatures. (See Factors Affecting Performance, page 20.)
- Avoid overloading and improper loading. (See Preparing and Loading Dishes, pages 13-16.)
- Use fresh detergent. Old detergent is ineffective.
- Make sure rinse aid dispenser is filled.
- Check to see that proper amount of detergent is being used for cycle selected. (See Detergent Dispenser, page 17.)
- Home water pressure may be too low—it should be 20 to 120 pounds per square inch (psi).

DISHWARE CHIPPED

- Load with care and do not overload. (See Preparing and Loading Dishes, pages 13-16.)
 - Place delicate items in top rack.
 - Place glasses securely against pins and not over pins.
 - Load items so they are secure and don't jar loose when moving racks in and out. Move racks in and out slowly.
 - Make sure tall glasses and stemware will clear top of tub when rack is pushed in.
 - It is recommended to wash fine antique china and crystal by hand.
-

DISHWARE STAINED OR DISCOLORED

- Tea and coffee can stain cups. Remove the stains by hand washing in a solution of 1/2 cup (120 ml) bleach and one quart (1 L) of warm water. Rinse thoroughly.
- Iron deposits in water can cause a yellow or brown film. A water filter installed in-line with your water supply will correct this problem.
- Aluminum utensils can leave gray/black marks when they rub against other items. Load properly.
- Certain high acid foods can cause discoloration of stainless steel and plastics if allowed to sit for a long period. Use the Rinse cycle or rinse by hand if not operating dishwasher at once.
- Mixing stainless steel and silver utensils in silverware basket can cause pitting of the stainless steel blades. Avoid mixing stainless steel and silver.

ETCHING

- Using too much detergent in soft or softened water causes this film that cannot be removed.
- Adjust the amount of detergent based on the water hardness. (Check Detergent Usage Guide, page 18.)
- Lower the water temperature.

DETERGENT LEFT IN DISPENSER CUP

- Detergent may be old. Discard and use fresh detergent.
- Be sure water action can reach the dispenser.
- Check to see if cycle has been completed.
- Make sure items do not prevent the detergent dispenser from opening.
- Make sure the upper rack is firmly attached to the nozzle on the back of the tub before closing the door.

26 Solutions to Common Problems

DISHWASHER LEAKS

- Use only fresh detergent designed for automatic dishwashers. Measure detergent carefully. Try a different brand.
- Spilled rinse aid can cause foam and lead to overflowing. Wipe up any spills with a damp cloth.
- Check to see that dishwasher is level (See Installation Instructions).

NORMAL SOUNDS YOU WILL HEAR

- Normal sounds include water fill, water circulation and motor sounds.
- Pump pulsing will cause motor speed to increase and decrease at regular intervals during cycles.

WATER IN THE BOTTOM OF THE TUB

- It is not normal for water to remain in the bottom of the tub at the end of a cycle. If water remains in the bottom of the tub at the end of a cycle, the dishwasher may not be draining properly. (See Dishwasher Does Not Drain Properly, page 27.) The filter may also need to be cleaned. (See Care of Filter, page 21.) *Note: It is normal to see a small amount of water under the filter at the end of a cycle.*

DISHWASHER WON'T RUN

- Check to see if circuit breaker is tripped or if a fuse is blown.
 - Make sure water supply is turned on.
 - Check to see if cycle is set correctly. (See Operating Instructions, pages 8-12.)
 - Check to see if the DELAY START option has been selected.
 - Make sure door is closed and latched.
-

DISHWASHER DOES NOT DRAIN PROPERLY

- If unit is hooked up to a garbage disposal, make sure the disposer is empty.
- If unit is hooked up to a new food waste disposer, check to see if the “knockout” plug located inside the disposal inlet has been removed.
- Check to see if drain hose is kinked.
- Make sure cycle is complete, not in a pause.

CYCLE TAKES A LONG TIME

- Check to see if cycle is in a water heating delay.
- Check to see if the delay start option been selected.
- Check to see if the sanitize option been selected.

DISHWASHER WON'T FILL

- Check to see if the water supply is turned on.
- Add 1/2 cup of water to the bottom of the unit and start again.

DISHWASHER HAS AN ODOR

- Soiled dishes left in dishwasher too long can create an odor. Use Rinse cycle.
- There will be a “new” smell when first installed. This is normal.
- Check to see if unit is draining properly (See Dishwasher Does Not Drain Properly, page 27).

28 Solutions to Common Problems

REMOVING SPOTS AND FILM

Hard water can cause lime deposit buildup on the interior of the dishwasher. Dishes and glasses may also get spots and film for a number of reasons (See Glassware/Flatware Spotted or Cloudy, page 24).

To remove build-up, spots and film, clean using the following instructions:

- 1 Load clean dishes and glasses in normal manner. Do not load any metal utensils or silverware.
- 2 Do not add detergent.
- 3 Select the NORMAL WASH cycle. Press START/CANCEL pad and close door.
- 4 Allow dishwasher to run until it begins the second fill. Open door and pour 2 cups of white vinegar into the bottom of dishwasher.
- 5 Close and latch door and allow cycle to finish.

NOTE

If these conditions persist, a home water softener should be considered.

DISHWASHER WARRANTY *Your dishwasher is protected by this warranty*

	WARRANTY PERIOD	THROUGH OUR AUTHORIZED SERVICERS, WE WILL:	THE CONSUMER WILL BE RESPONSIBLE FOR:
1-YEAR FULL WARRANTY	One year from original purchase date.	Pay all costs for repairing or replacing any parts of this appliance which prove to be defective in materials or workmanship.	Costs of service calls that are listed under NORMAL RESPONSIBILITIES OF THE CONSUMER.*
5-YEAR LIMITED WARRANTY	Second through fifth years from original purchase date.	Replace any electronic control that fails due to manufacturing defect. Replace any original upper or lower nylon coated rack that peels or rusts due to a manufacturing defect. Replace major components in the water distribution system which fails due to a manufacturing defect. This includes the motor, pump and lower wash arm, upper spray arm with associated supply tube, and filter assembly. Associated inlet and drain plumbing parts are not covered by this warranty.	Costs for pickup and delivery of the product required because of service; and all costs for labor and transportation. Associated inlet and drain plumbing parts.
LIFETIME LIMITED WARRANTY	Lifetime of the product.	Provide a replacement tub or door liner if the original tub or door liner fails to contain water because of a manufacturing defect.	Door seals; any costs for pickup and delivery of the product required because of service; and all costs for labor and transportation.
LIMITED WARRANTY (Applicable to the State of Alaska)	Time periods listed above.	All of the provisions of the full warranties above and the exclusions listed below apply.	Costs of the technician's travel to the home and any costs for pick up and delivery of the appliance required because of service.

In the U.S.A., your appliance is warranted by Electrolux Home Products, Inc. We authorize no person to change or add to any of our obligations under this warranty. Our obligations for service and parts under this warranty must be performed by us or an authorized Electrolux Home Products, Inc. servicer. In Canada, your appliance is warranted by Electrolux Canada Corp.

***NORMAL RESPONSIBILITIES OF THE CUSTOMER**

This warranty applies only to products in ordinary household use, and the consumer is responsible for the items listed below:

1. Proper use of the appliance in accordance with instructions provided with the product.
2. Proper installation by an authorized servicer in accordance with instructions provided with the appliance and in accordance with all local plumbing, electrical and/or gas codes.
3. Proper connection to a grounded power supply of sufficient voltage, replacement of blown fuses, repair of loose connections or defects in house wiring.
4. Expenses for making the appliance accessible for servicing, such as removal of trim, cupboards, shelves, etc., which are not a part of the appliance when it was shipped from the factory.
5. Damages to finish after installation.

EXCLUSIONS

This warranty does not cover the following:

1. **CONSEQUENTIAL OR INCIDENTAL DAMAGES SUCH AS PROPERTY DAMAGE AND INCIDENTAL EXPENSES RESULTING FROM ANY BREACH OF THIS WRITTEN OR ANY IMPLIED WARRANTY.**
Note: Some states do not allow the exclusion or limitation of incidental or consequential damages, so this limitation or exclusion may not apply to you.
2. Service calls which do not involve malfunction or defects in workmanship or material, or for appliances not in ordinary household use. The consumer shall pay for such service calls.
3. Damages caused by services performed by persons other than from Electrolux Home Products, Inc., Electrolux Canada Corp., or their authorized servicers; use of parts other than genuine Electrolux parts; parts obtained from persons other than such servicers; or external causes such as abuse, misuse, inadequate power supply or acts of God.
4. Products whose serial number has been removed or altered and cannot be readily determined.

IF YOU NEED SERVICE

Keep your bill of sale, delivery slip, or some other appropriate payment record. The date on the bill establishes the warranty period should service be required. If service is performed, it is in your best interest to obtain and keep all receipts. This written warranty gives you specific legal rights. You may also have other rights that vary from state to state. Service under this warranty must be obtained by contacting Electrolux Home Products, Inc. or Electrolux Canada Corp.

This warranty only applies in the 50 states of the U.S.A. and Puerto Rico, and Canada. Product features or specifications as described or illustrated are subject to change without notice. All warranties are made by Electrolux Home Products, Inc. In Canada, your appliance is warranted by Electrolux Canada Corp.