

# SERIES 2000 FRYER MANUAL



*"Serving Those Who Serve The Very Best"*

## INSTANT RECOVERY® GAS FRYER

**READ AND SAVE THIS MANUAL FOR FUTURE REFERENCE**

Record the Model No. and Serial of this Instant Recovery® Gas Fryer in the space provided below.

Serial No. \_\_\_\_\_

Model No. \_\_\_\_\_

**Keep these numbers for future reference**

**IMPORTANT:** Keep a copy of your bill of sale. The date on the bill establishes the warranty period should service be required. If service is performed, it is in your interest to obtain and keep all receipts. Keating commercial fryers are intended for other than household use.

### CONTENTS:

Important Safety Instructions . . . . .	i	Lighting . . . . .	3-5
<b>INTRODUCTION</b> . . . . .	1	Cooking . . . . .	5-6
<b>INSTALLATION</b>		Shutdown . . . . .	6
Damage During Shipment . . . . .	1	Oil Breakdown . . . . .	6
<b>FIRST STEPS</b>		Draining . . . . .	6
Positioning . . . . .	1	Cleaning and Boil-Out . . . . .	6-8
Ventilation . . . . .	1	<b>OPERATOR SELF HELP CHECK LIST</b>	<b>8</b>
National Code Requirement . . . . .	1	<b>PREVENTATIVE MAINTENANCE</b>	
Gas Connectors & Pipe Size . . . . .	2	Preventive Maintenance Chart . . . . .	9
Flexible Gas Connection & Quick Disconnect		Hi-Limit Check Bi-Monthly . . . . .	9
Devices . . . . .	2	Thermostat Calibration . . . . .	9
Restraining Devices . . . . .	2	Thermostat Bulb Positioning . . . . .	9
Electrical Connection . . . . .	2	Timer . . . . .	10
Leveling . . . . .	3	<b>WARRANTY REPAIRS</b>	
<b>PLACING YOUR KEATING FRYER IN OPERA-</b>		Ordering Parts . . . . .	11
<b>TION</b>		Parts List . . . . .	11-15
Filling . . . . .	3	Wiring Diagrams . . . . .	15-18

This Owner's Guide provides specific operating instructions for your model. Use the Instant Recovery® Fryer only as instructed in this Service Guide.

### Versión en español

Si desea obtener una copia en español de este Manual del Usuario, sírvase escribir la dirección que se incluye a continuación.

**1-800-KEATING**  
**www.keatingofchicago.com**



Purchaser should post in a prominent location instructions to be followed in the event the user smells gas. This information shall be obtained by consulting the local gas supplier.



**⚠ WARNING**

**IF NOT INSTALLED, OPERATED AND MAINTAINED IN ACCORDANCE WITH THE MANUFACTURER'S INSTRUCTIONS, THIS PRODUCT COULD EXPOSE YOU TO SUBSTANCES IN FUEL OR IN FUEL COMBUSTION WHICH CAN CAUSE DEATH OR SERIOUS ILLNESS AND WHICH ARE KNOWN TO THE STATE OF CALIFORNIA TO CAUSE CANCER, BIRTH DEFECTS OR OTHER REPRODUCTIVE HARM.**

**⚠ WARNING**

**PROPANE GAS MAY EVENTUALLY LOSE ITS ODOR AND PRECAUTIONS SHOULD BE TAKEN TO ASSURE THAT PROPANE GAS IS NOT PRESENT EVEN THOUGH YOU DO NOT DETECT AN ODOR. IF THERE IS ANY DOUBT, YOU SHOULD CALL YOUR LOCAL PROPANE GAS SUPPLIER FOR ASSISTANCE.**

**THE EQUIPMENT IS TO BE INSTALLED TO COMPLY WITH THE BASIC PLUMBING CODE OF THE BUILDING OFFICIALS AND CODE ADMINISTRATORS INTERNATIONAL, INC. (BOCA) AND THE FOOD SERVICE SANITATION MANUAL OF THE FOOD AND DRUG ADMINISTRATION (FDA).**

---

\*As continuous product improvement occurs, specifications may be changed without notice.

## INTRODUCTION

Instructions in this manual should be read thoroughly before attempting to operate this Keating Gas Fryer. All installation and service on Keating equipment must be performed by qualified, certified, licensed and/or authorized installation or service personnel.

Operating information for Keating equipment has been prepared for use by qualified and/or authorized personnel.

Keating equipment is made in the U.S.A. and has American sizes of hardware. All metric conversions are approximate.

## INSTALLATION INSTRUCTIONS

Proper installation will assure top performance. Alteration to your equipment will void the warranty. Before uncrating, check equipment carefully for damage.

### IF EQUIPMENT ARRIVES DAMAGED

Keating does not assume responsibility for loss or damage incurred in transit.

### IMPORTANT

This merchandise has been thoroughly inspected and carefully packed before leaving our plant. Responsibility for its safe delivery was assumed by the carrier at the time of shipment. Claims for loss or damage to the contents should, therefore, be made upon the carrier, as follows:

### CONCEALED LOSS OR DAMAGE

Concealed loss or damage means loss or damage which does not become apparent until the merchandise has been unpacked. The contents may be damaged in transit due to rough handling even though the carton may not show external damage. When the damage is discovered upon unpacking, make a written request for inspection by the carrier's agent within fifteen days of the delivery date. Then file a claim with the carrier since such damage is the carrier's responsibility. By following these instructions carefully, we guarantee our full support of your claims to protect you against loss from concealed damage.

### VISIBLE LOSS OR DAMAGE

Any external evidence of loss or damage must be noted on the freight bill or express receipt, and signed by the carrier's agent. Failure to adequately describe such external evidence of loss or damage may result in the carrier refusing to honor a damage claim. The form required to file such a claim will be supplied by the carrier.

**DO NOT RETURN DAMAGED MERCHANDISE TO KEATING. FILE YOUR CLAIM AS ABOVE.**

## FIRST STEPS

### POSITIONING

Keep appliance area free and clear of any combustibles. Position the Keating Gas Fryer 6 inches (152mm) from any combustible material. A minimum of 24 inches (610mm) should be provided at the front of the Keating Gas Fryer for servicing and proper operation. Air for combustion enters the fryer from the bottom of the cabinet and the bottom of the control panel.

### DO NOT BLOCK BOTTOM OF KEATING INSTANT RECOVERY® GAS FRYER CABINET. DO NOT OBSTRUCT FLUE.

Your Keating Instant Recovery® Gas Fryer is designed to be serviced from the front.

### MINIMUM CLEARANCE

	<u>Clearances</u>	
	<u>Combustible Construction</u>	<u>Noncombustible Construction</u>
Back	6"	0"
Right Side	6"	0"
Left Side	6"	0"

### SUITABLE FOR COMBUSTIBLE FLOORS VENTILATION

The Keating Gas Fryer must be installed in an area providing adequate air supply and ventilation. Do not obstruct the flow of combustion and ventilation air. Proper ventilation is one of the important considerations for efficient operation of the Keating Gas Fryer. It should be installed so that the products of combustion are removed efficiently without producing drafts that will interfere with proper burner operation. The intake for the exhaust fan should not be placed close to the flue of the Keating Gas Fryer to insure proper air flow necessary for combustion. The area around the front and bottom of the Keating Gas Fryer must be kept clear and unobstructed. In the U.S.A. the ventilation systems must conform to the ANSI/NFPA96 latest edition. "A minimum of 18" (457mm) should be maintained between the flue outlet and the lower edge of the grease filters." Must be installed at least 16" away from any open flame. It is the responsibility of the owner and the local installer to comply with national and local codes.

### NATIONAL CODE REQUIREMENT

The installation must conform with local codes, or in the absence of local codes, with the National Fuel Gas code, ANSI Z223.1 or the Natural gas Installation Code, CAN/CGA-B149.1 or the Propane Installation Code, CAN/CGA-B149.2. Flexible connectors must comply to ANSI Z221.69/CAN/CGA1.16. Keating equipment is designed and manufactured to operate

only on the type of gas specified by the user and indicated on the serial plate located inside the door. The gas may be natural, propane or manufactured. The type of gas cannot be converted to another gas fuel by turning or engaging a switch.

### GAS CONNECTIONS AND PIPE SIZE

A single Keating Gas Fryer requires a standard gas pipe size of 3/4 inch (19mm) I.D. connection. Multiple fryers with a common manifold will require a minimum of 1 1/4 inch I.D. gas supply line. The size of the gas supply pipe is very important. If the pipe is too small you will have low gas pressure at the Keating Gas Fryer manifold. Low gas pressure will cause slow recovery and/or delayed ignition. If you have a question about gas pipe size call your local gas company.

#### ▲ CAUTION

Before connecting new pipe to the Keating Gas Fryer the pipe must be blown out to remove all foreign particles. These particles in the controls or burners may cause improper or dangerous operating conditions.

#### ▲ CAUTION

Pipe joint compounds that are used on threaded joints of appliance piping shall be resistant to the action of liquefied petroleum gases (Loctite PST 56765). When using pipe joint compound do not apply to the first two threads. Use only very small amount and only on male threads. This will prevent clogging of burner orifices and the gas valve. Never use compound on female threads as it might be pushed into the gas valve.

Have your installer check for gas leaks using a soap and water solution before operating. **DO NOT USE AN OPEN FLAME TO CHECK FOR GAS LEAKS.**

1.) The Keating Gas Fryer and its individual shut off valves must be disconnected from the gas supply piping system during any pressure testing of that system at test pressures in excess of 1/2 psi (3.45kPa) (13.84 in WC) High pressure can damage the gas valve causing a hazardous condition.

2.) The appliance must be isolated from the gas supply piping system by closing its individual manual shutoff valve during any pressure testing of the gas supply piping system at test pressures equal to or less than 1/2 psi (3.45 kPa).



**NOTE:** Line pressure must be kept below 10" (Nat), 13" (LP) to avoid damage to the gas valve.

The required gas pressure for proper operation of each fryer is 4" water column for natural gas and 10" water column for propane gas at the burner manifold.

If more than one gas unit is on the same supply line, you may require a larger line. Consult your local gas company to assure adequate volume and pressure. Refer to serial plate for proper gas requirement for your particular model.

### FLEXIBLE GAS CONNECTORS AND QUICK DISCONNECT DEVICES

For an appliance equipped with casters:

The installation shall be made with a connector that complies with the Standard for Connectors for Movable Gas Appliances, ANSI Z21.69 or the Standard for Connectors for Moveable Gas Appliances, CAN/CGA-6.16, and a quick disconnect device that complies with the Standard for Quick-Disconnect Devices for Use With Gas Fuel, ANSI Z21.41 or the Standard for Quick Disconnect Devices for Use with Gas Fuel, CAN1-6.9.

### RESTRAINING DEVICES

1.) Adequate means must be provided to limit the movement of the appliance without depending on the connector and the quick-disconnect device or its associated piping to limit the appliance movement.



Fryer must also be restrained to prevent tipping when installed so that hot liquid splashing is avoided.

2.) The restraint means must be attached to the rear of the Keating Gas Fryer within 2" of the center line width and approximately 1-5/8" from the bottom of the cabinet back to allow the restraining bolt to be anchored to the cabinet back between the cabinet bottom and inner liner.

**IF DISCONNECTION OF THE RESTRAINT IS NECESSARY, IT MUST BE RECONNECTED WHEN THE KEATING GAS FRYER IS RETURNED TO ITS ORIGINALLY INSTALLED POSITION.**

### INSTALLATION

The installer is responsible for attaching the tipping restraint.

### ELECTRICAL CONNECTION

The Keating Gas Fryer, when installed, must be electrically grounded in accordance with local codes, or in the absence of local codes, the National Electrical Code, ANSI/NFPA No. 70. or the Canadian Electrical Code, CSAC-22.2 as applicable. A wiring diagram is located on the last page. In the U.S.A. and Canada, the electrical supply must be 120 VAC, 60 Hz.



#### ▲ WARNING

This appliance is equipped with a three-prong 120 Volt NEMA 5-15 (grounding) plug for your protection against shock hazard and should be plugged directly into a properly grounded and polarized three-prong

receptacle. Do not cut or remove the grounding prong from this plug. (Model AA has no electric connection).



The Keating Gas Fryer will operate at its highest efficiency when properly leveled. Place a level on the fryer from side to side. For fryer on legs, the bottom foot of the leg is adjustable. Turn counterclockwise to decrease height, or clockwise to increase height until level. For fryers with casters, the casters are adjustable by loosening the jam nut and turn the caster in or out. When the desired level is reached, tighten the jam nut. Adjustments of more than 3/4" are not recommended on any caster. The same procedure should be followed to level the fryer from front to back.

## PLACING KEATING GAS FRYER IN OPERATION

Never leave your fryer operating unattended. (When all previous instructions have been completed). Check the serial plate on the panel (inside cabinet) to determine if the burner is set up for the proper type gas before connecting the quick-disconnect or piping from the building gas supply pipe.

- a. Maximum incoming gas pressure  
NATURAL GAS – 7 inches W.C. with burners on  
LP GAS – 11 inches W.C. with burners on

If a popping noise is heard from the fryer during the cooking cycle, the following checks must be made in this order:

- b. Fryer manifold gas pressure  
NATURAL GAS – 4 inches W.C. with burners on  
LP – 10 inches W.C. with burners on

**ALWAYS disconnect fuel source and power supply before servicing.**

**NEVER move a fryer when full of oil.**

**NEVER introduce objects or liquids into fryer, while operational, which are not designed or made for cooking.**

THIS FRYER MAY NOT BE ALTERED, MODIFIED OR CHANGED IN ANY WAY.

### FILLING

**NOTE:** Before filling the fryer make certain the fryer vessel is sanitized, dry and the drain valve is completely closed.

**NOTE:** We recommend that solid shortening not be used in a Keating Gas Fryer if it is not equipped with a melt cycle. If solid shortening is used, it should be melted prior to filling the fryer vessel. Damage done by melting solid shortening in the fryer vessel will void the warranty.

### CAUTION

Oil expands when heated. The "Fill Level" line has been provided to ensure optimum cooking while ensuring the safety of the operator. Do not overfill the fryer vessel.

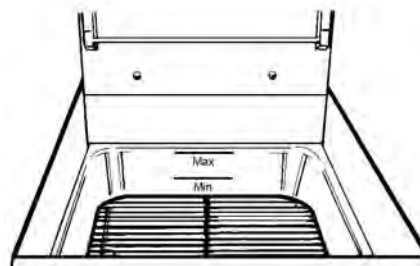

Fill Level Line

Fill the fryer vessel with oil or MELTED solid shortening up to the "Fill Level" line.

### CAUTION

**BE SURE THE HEAT TRANSFER TUBES ARE COMPLETELY COVERED WITH OIL BEFORE SWITCHING THE FRYER ON. IF OIL LEVEL DROPS BELOW TOP OF HEAT TRANSFER TUBES, SEVERE DAMAGE TO FRYER AND INJURY TO OPERATOR MAY RESULT.**

### LIGHTING INSTRUCTIONS

(See lighting instructions plate attached to the inner door of Keating Gas Fryer.) Model AA does not require an electrical connection.

Make sure that the Keating Gas Fryer is plugged in. If not your fryer will not operate. Make sure that the main gas valve on the gas supply line to the Keating Gas Fryer is in the "ON" position.

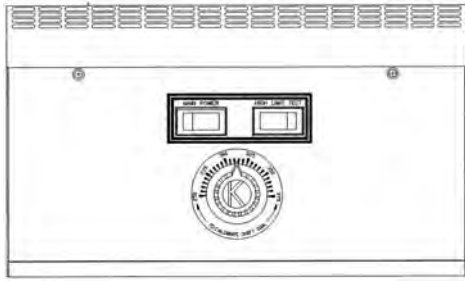

AA CONTROL PANEL

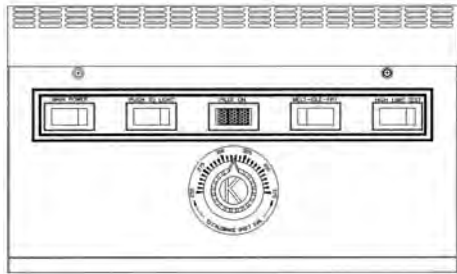

BB CONTROL PANEL

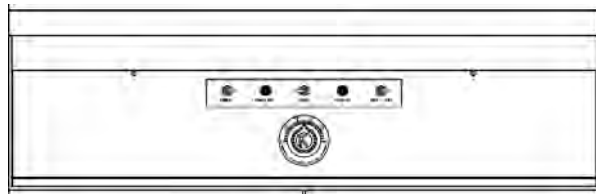

34x24 BB CONTROL PANEL

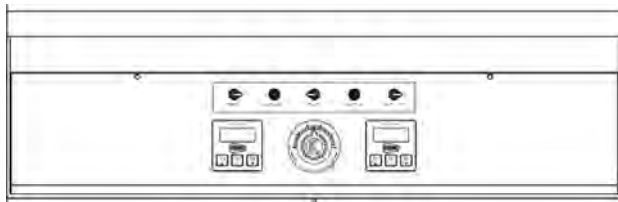

34x24 TS CONTROL PANEL

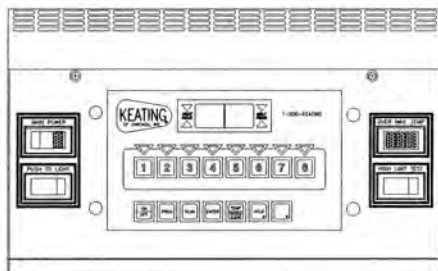

TS CPU CONTROL PANEL

AIR IN THE GAS SUPPLY LINE MAY REQUIRE A LONGER THAN NORMAL PERIOD OF TIME TO LIGHT YOUR FRYER DURING INITIAL INSTALLATION OR AFTER OVERNIGHT SHUTDOWN

**NOTE:** Unless you have an AA model your fryer cannot be operated during a power failure.

## AA MODELS OPERATING INSTRUCTIONS

### START-UP PROCEDURE

**WARNING: DO NOT START FRYER WITHOUT FIRST FILLING FRYER POT.**

- STEP 1. Set thermostat to the "OFF" position.
- STEP 2. Turn "MAIN POWER" switch to the "OFF" position.
- STEP 3. Turn gas valve knob to "PILOT" position.
- STEP 4. Light constant pilot located on left side of pilot runner tube.
- STEP 5. Push and hold the gas valve knob for 30 seconds and release.
- STEP 6. With the pilot still on, turn gas valve knob to the "ON" position.
- STEP 7. Set thermostat to desired temperature, turn "MAIN POWER" switch to the "ON" position. The burners will come on.

### HIGH LIMIT TEST PROCEDURE (All Models): DO BI-MONTHLY

- STEP 1. Place a suitable thermometer in the oil on the front left corner of the fryer 2" from the top to check temperature.
- STEP 2. Set thermostat to 375°F after burners go off. Push and hold the "HIGH LIMIT TEST" switch. The burners will come on.
- STEP 3. When 425°F is reached the burners go off. Now it is ok to release test switch.
- STEP 4. If the high limit thermostat does not shut down the burners between 425°-450°F as read on the thermometer, the high limit must be replaced immediately.
- STEP 5. To re-start the fryer it must be cooled down to cooking temperature and the red reset button on the high limit thermostat pushed. Return to STEP 3 in the start-up procedure.

### SHUTDOWN PROCEDURE

- STEP 1. Set thermostat to the "OFF" position.
- STEP 2. Turn "MAIN POWER" switch to the "OFF" position.
- STEP 3. Turn gas valve knob to the "OFF" position.
- STEP 4. Turn gas supply valve to the "OFF" position.
- STEP 5. Check to make sure all burners and pilot are out.

## BB MODELS OPERATING INSTRUCTIONS

### START-UP PROCEDURE

**WARNING: DO NOT START FRYER WITHOUT FIRST FILLING FRY POT.**

- STEP 1. Set "MELT-IDLE-FRY" switch to "IDLE" position and thermostat to the "OFF" position.
- STEP 2. Turn "MAIN POWER" switch to the "ON" position.
- STEP 3. Hold the "PUSH TO LIGHT" switch in until the amber "PILOT ON" light comes on.
- STEP 4. Set thermostat to desired temperature.
- STEP 5. Set "MELT-IDLE-FRY" switch to "FRY." The burners will come on. Select "MELT" with solid shortening until liquid shortening is 1" from full, then switch to the "FRY" position.

**HIGH LIMIT TEST PROCEDURE: DO BI-MONTHLY**

- STEP 1. Place a suitable thermometer in the oil on the front left corner of the fryer 2" from the top to check temperature.
- STEP 2. Set thermostat to 375°F after burners go off. Push and hold the "HIGH LIMIT TEST" switch. The burners will come on.
- STEP 3. When 425°F is reached the burners go off. Release test switch.
- STEP 4. If the high limit thermostat does not shut down the burners between 425°-450°F as read on the thermometer, the High Limit must be replaced immediately.
- STEP 5. To re-start the fryer it must be cooled down to cooking temperature and the red reset button on the high limit thermostat pushed. Return to STEP 3 in the start-up procedure.

**SHUTDOWN PROCEDURE**

- STEP 1. Set "MELT-IDLE-FRY" switch to "IDLE" position and thermostat to the "OFF" position.
- STEP 2. Turn "MAIN POWER" switch to the "OFF" position. Its green light will go off.
- STEP 3. Turn gas supply valve to the "OFF" position.
- STEP 4. Check to make sure all burners and pilot are out.

**TS MODELS OPERATING INSTRUCTIONS**

**START-UP PROCEDURE**

**WARNING: DO NOT START FRYER WITHOUT FIRST FILLING FRYER POT.**

- STEP 1. Set "MELT-IDLE-FRY" switch to "IDLE" position and thermostat to the "OFF" position.
- STEP 2. Turn "MAIN POWER" switch to "ON" position. Its green light and the timers will come on.
- STEP 3. Light constant pilot located on left side of pilot runner tube.
- STEP 4. Hold the "PUSH TO LIGHT" switch for 30 seconds. The pilot runner tube will light.
- STEP 5. Set thermostat to desired temperature.
- STEP 6. Set "MELT-IDLE-FRY" switch to "FRY" with oil in the fry pot. The burners will come on.

Select "MELT" with solid shortening until liquid shortening is 1" from full mark then switch to the "FRY" position. Burners will come on.

**HIGH LIMIT TEST PROCEDURE: DO BI-MONTHLY**

- STEP 1. Place a suitable thermometer in the oil on the front left corner of the fryer 2" from the top to check temperature.
- STEP 2. Set thermostat to 375°F after burners go off. Push and hold the "HIGH LIMIT TEST" switch. The burners will come on.
- STEP 3. When 425°F is reached the burners go off and the "OVER MAX TEMP" red light will come on. Release test switch.
- STEP 4. If the high limit thermostat does not shut down the burners between 425°-450°F as read on the thermometer, the high limit must be replaced.
- STEP 5. To re-start the fryer it must be cooled down to cooking temperature and the red reset button on the high limit thermostat pushed. The red light will go off. Return to STEP 3 in the start-up procedure.

**SHUTDOWN PROCEDURE**

- STEP 1. Set "MELT-IDLE-FRY" switch to "IDLE" position and thermostat to the "OFF" position.
- STEP 2. Turn "MAIN POWER" switch to the "OFF" position. Its green light will go off.
- STEP 3. Turn gas supply valve to the "OFF" position.
- STEP 4. Check to make sure all burners and pilot are out.

**COOKING**

Keating's Instant Recovery® Gas Fryer is designed to provide maximum production efficiency and deliver high quality food products. Low- temperature cooking, highly polished stainless steel and a true COLD ZONE mean extended oil life. Follow cooking procedures below for your model.

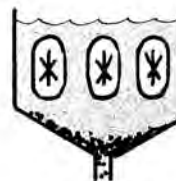

**Cold Zone**

### **▲ CAUTION**

**OPERATION OF THIS FRYER SHOULD BE LIMITED TO PERSONNEL WHO HAVE BEEN THOROUGHLY TRAINED IN OPERATING PROCEDURES.**

Set thermostat to the desired frying temperature.

### **▲ CAUTION**

**CARE SHOULD BE TAKEN WHEN LOWERING BASKETS INTO FRYER TO PREVENT SPLASHING HOT OIL FROM FRYER VESSEL.**

If your fryer has timers, push "Start-Stop" button of electronic timer(s). For fryers with automatic basket lift, basket(s) will lower into fryer vessel.

When timer(s) sounds, carefully lift basket(s) out of hot oil. For fryers with automatic basket lift, a buzzer will sound and the basket(s) will rise automatically. Allow oil to drain before removing.

### **▲ CAUTION**

**DO NOT LIFT BASKETS DIRECTLY OUT OF THE FRYER VESSEL WITHOUT DRAINING AS SEVERE INJURY MAY RESULT**

**USE ONLY KEATING APPROVED BASKETS IN YOUR FRYER. NEVER OVERFILL FRY BASKETS. DO NOT BANG BASKETS ON BASKET HANGERS OR ON FRYER VESSEL.**

Place basket(s) on basket hanger rods on splashback of fryer and allow to drain.

### **SHUTDOWN INSTRUCTIONS**

Always turn the fryer off each night.

1. See Shutdown procedure.

### **OIL BREAKDOWN**

As part of a "Preventive Maintenance Program", the oil in your fryer needs to be filtered regularly. The initial investment in the frying system is less than the total overall costs of oil during the life of the fryer, and with regular filtering, you can realize substantial savings in oil costs, as well as, maintenance charges. We have listed some of the conditions which are catalysts in the breakdown of oil:

1. Contact with Oxygen
2. Carbonization of Crumbs and Food Particles
3. Non-Stainless Steel Surfaces
4. Keep Salt and Seasonings Away From Oil
5. Prolonged High Temperatures

### **DRAINING**



Operator in safety gear

### **▲ CAUTION**

**ALWAYS SHUT THE FRYER OFF COMPLETELY BEFORE DRAINING. THE FRYER SHOULD BE DRAINED ONLY UNDER THE SUPERVISION OF PROPERLY TRAINED PERSONNEL. A DRAIN PIPE AND COVERED CONTAINER SUITABLE FOR USE WITH HOT OIL SHOULD BE USED TO ENSURE THE SAFETY OF THE OPERATOR.**

1. Operator should be outfitted with proper attire including:
  - Oil and heat resistant gloves
  - Oil and heat resistant apron
  - Safety goggles
  - Oil and heat resistant footwear
2. Turn off the fryer and open the door.
3. Put suitable container under drain valve.
4. Drain oil from fryer by slowly turning handle. The drain will be completely open after 1/4 turn.
5. After fryer drains close the drain valve.
6. Filtering may be done at this step.

**NOTE:** Fryers with a central filter will drain differently.

### **CLEANING AND BOIL-OUT FOR A SINGLE FRYER**

When cleaning and boiling out your fryer use Keating Sea Powder and Keating Klenzer to keep your fryer in top condition.

1. Operator should be outfitted with proper attire including:
  - Oil and heat resistant gloves
  - Oil and heat resistant apron
  - Safety goggles
  - Oil and heat resistant footwear

Turn the fryer off. Remove baskets and screen.

2. Drain oil from fryer, see draining.



**⚠ CAUTION**

A KEATING FRYER OR FILTER SHOULD BE DRAINED ONLY UNDER THE SUPERVISION OF PROPERLY TRAINED PERSONNEL. WHEN DISCARDING OIL, A COVERED RECEPTACLE APPROVED FOR USE WITH HOT OIL SHOULD BE USED. USE OF A NON-APPROVED RECEPTACLE OR METHOD OF DRAINING THE OIL COULD JEOPARDIZE THE SAFETY OF THE OPERATOR.

3. Remove oil container to a secure area to prevent accidental spillage.
4. Fill fryer vessel to "Fill Level" line with water.
5. Set thermostat and turn fryer on to bring water to a gentle boil. Once boil has been reached, turn fryer off.

**⚠ CAUTION**

UNDER NO CIRCUMSTANCES SHOULD THE FRYER AND FILTER BE LEFT UNATTENDED DURING BOIL-OUT. TRAINED PERSONNEL MUST BE PRESENT DURING THE PROCEDURE TO PREVENT BOIL OVER OR TO TURN OFF THE POWER IF WATER DROPS BELOW HEATING TRANSFER TUBES.

6. Dissolve 2/3 cup of Keating Sea Powder for every five gallons of water and let soak for 1/2 hour. If there is a large build-up of carbonized grease, allow for fryer to soak overnight.
7. While soaking, a natural fiber brush may be used to scrub the tubes and inside walls of fryer. Drain the water and Sea Powder into a dry suitable receptacle and remove from cooking area. Sprinkle Keating Klenzer liberally on tubes and sides of fryer vessel. A non-abrasive scouring pad may be used to remove the now softened carbonized grease. Thoroughly rinse fryer vessel with potable water to remove all Klenzer. Prior to refilling with oil, wipe the inside of the fryer vessel making sure all water and Klenzer have been removed.

**NOTE:** Do not pump water through the filter system.

**DO NOT DAMAGE OR REPOSITION THERMOSTAT PROBE AS THIS MAY AFFECT THE ACCURACY OF THE FRYER.**

**⚠ CAUTION**

**DO NOT MIX WATER AND HOT OIL**

8. Close the drain valve.
9. Check thermostat bulb positioning.
10. Refill the fryer with new or filtered oil.

**TO AVOID DAMAGING THE FRYER, DO NOT POWER WASH, SPRAY OR HOSE IT DOWN WHILE CLEANING IT.**

**CLEANING AND BOIL-OUT FOR A FRYER WITH ATTACHED FILTER SYSTEM**

When cleaning and boiling out your fryer use Keating Sea Powder and Keating Klenzer to keep your fryer in top condition.

**SAFE & EASY FILTER (SIDE VIEW)**

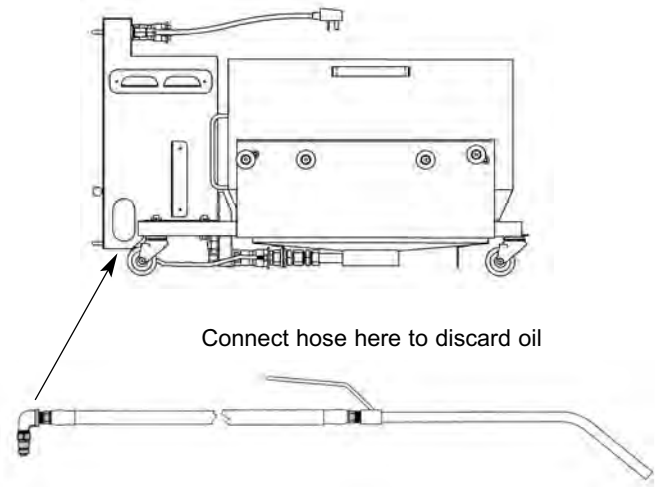

Connect hose here to discard oil

**⚠ CAUTION**

A KEATING FRYER OR FILTER SHOULD BE DRAINED ONLY UNDER THE SUPERVISION OF PROPERLY TRAINED PERSONNEL. WHEN DISCARDING OIL, A COVERED RECEPTACLE APPROVED FOR USE WITH HOT OIL SHOULD BE USED. USE OF A NON-APPROVED RECEPTACLE OR METHOD OF DRAINING THE OIL COULD JEOPARDIZE THE SAFETY OF THE OPERATOR.

1. Operator should be outfitted with proper attire including:

- Oil and heat resistant gloves
- Oil and heat resistant apron
- Safety goggles
- Oil and heat resistant footwear

2. Turn the fryer off.

A cleaning hose and wand have been provided for discarding oil.

3. Attach cleaning hose to quick disconnect located on the bottom right side of your filter.
4. Remove baskets and screen. Drain fryer into the central filter drawer.

5. Open the discard valve located near the quick disconnect in the filter cabinet.
6. The hose may now be used to pump the oil into the shortening handling system and discarded properly.
7. Remove oil container to a secure area to prevent accidental spillage.
8. Fill fryer vessel to "Fill Level" line with water.
9. Set thermostat and turn fryer on to bring water to a gentle boil. Once boil has been reached, turn fryer off.

**▲ WARNING**

**UNDER NO CIRCUMSTANCES SHOULD THE FRYER AND FILTER BE LEFT UNATTENDED DURING BOIL-OUT. TRAINED PERSONNEL MUST BE PRESENT DURING THE PROCEDURE TO PREVENT BOIL OVER OR TO TURN OFF THE POWER IF WATER DROPS BELOW HEATING TRANSFER TUBES.**

10. Dissolve 2/3 cup of Keating Sea Powder for every five gallons of water and let soak for 1/2 hour. If there is a large build-up of carbonized grease, allow fryer to soak overnight.
11. While soaking, a natural fiber brush may be used to scrub the tubes and inside walls of fryer. Pump the water and Sea Powder into a dry suitable receptacle and remove from cooking area. Sprinkle Keating Klenzer liberally on tubes and sides of fryer vessel. A non-abrasive scouring pad may be used to remove the now softened carbonized grease. Thoroughly rinse fryer vessel with potable water to remove all Klenzer. Prior to refilling with oil, wipe the inside of the fryer vessel making sure all water and Klenzer have been removed.

**DO NOT DAMAGE OR REPOSITION THERMOSTAT PROBE AS THIS MAY AFFECT THE ACCURACY OF THE FRYER.**

**▲ CAUTION**

**DO NOT MIX WATER AND HOT OIL**

12. Close the drain valve and disconnect the cleaning hose.  
  
Quick disconnect will remain hot for approximately 15 minutes.
13. Check thermostat bulb positioning (should be 1 paper thickness away from heat tube).
14. Refill the fryer with new or filtered oil.

Wait until filter drawer is cool before cleaning, approximately 15 minutes.

15. Remove filter drawer, drain, clean and dry.
16. Prepare filter drawer and return to filter cabinet.

**TO AVOID DAMAGING THE FRYER, DO NOT POWER WASH, SPRAY OR HOSE IT DOWN WHILE CLEANING IT.**

17. Pump must be primed with oil after boil-out with water.

Failure to lubricate pump may cause severe damage to Filter System.

## OPERATOR SELF HELP

Before calling for service, review this list. It may save you both time and expense. This list includes common occurrences that are not the result of defective workmanship or materials in this appliance.

OCCURRENCE	SOLUTION
Fryer does not operate:	<ul style="list-style-type: none"> <li>■ Check power cord, unit plugged in?</li> <li>■ Thermostat is in the off position.</li> <li>■ Check gas supply.</li> <li>■ See figure below.</li> <li>■ Reset high limit.</li> </ul>

**NOTE:** For a fryer with a Central, Zero-Space™ Filter, or Safe & Easy Filter always check the rear drain operating handle before attempting to use the fryer. A safety switch prevents the fryer from operating if the handle is not pushed in completely and latched. (See figure 3-2)

Figure 3-2

Rear Drain Operating Handle

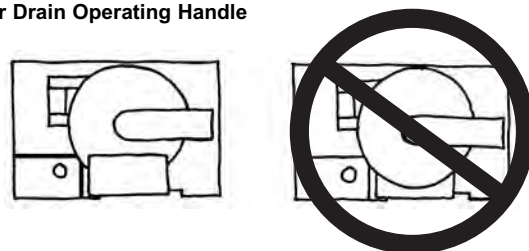

# PREVENTIVE MAINTENANCE

Preventive maintenance should be done in daily, weekly, monthly and yearly intervals as necessary. Following preventive maintenance procedures will help keep your fryer working efficiently. Proper care and servicing will lead to years of quality performance.

## PREVENTIVE MAINTENANCE CHART

TIME FRAME	OPERATOR/OWNER
Daily*	<ul style="list-style-type: none"> <li>• Check lights and controls.</li> <li>• Check that the oil is up to "Fill Level" Line.</li> <li>• Clean all baskets.</li> <li>• Drain, strain or filter oil.</li> </ul>
Weekly*	<ul style="list-style-type: none"> <li>• Drain and clean fryer.</li> <li>• Boil-out fryer.</li> </ul>
BiMonthly	<ul style="list-style-type: none"> <li>• Hi-Limit &amp; Test procedures.</li> </ul>
Monthly*	<ul style="list-style-type: none"> <li>• Check calibration of the thermostat.</li> </ul>
Yearly*	<p><b>QUALIFIED SERVICE PERSONNEL ONLY</b></p> <ul style="list-style-type: none"> <li>• Check burner flame color and adjust air shutters.</li> <li>• Remove and clean all orifices.</li> <li>• Check and replace radiants.</li> </ul>

\*High production facilities should be checked more often. Contact your local service company to perform maintenance and repairs.

### HI-LIMIT CHECK BI-MONTHLY

The manual Hi-Limit test button can be used to test the Hi-Limit Control by pushing and holding the button in until the fryer reaches the Hi-Limit temperature (425°F). Place an accurate thermometer in the oil. If the Hi-Limit Control doesn't shut off the fryer between 425°F and 450°F, have it replaced.

### THERMOSTAT CALIBRATION

You will need:

One screwdriver with 1/8" wide flat blade

One accurate fryer thermometer

1. Set thermostat to desired frying temperature.
2. Allow fryer to cycle three times.
3. Place an accurate thermometer in the oil.



Thermostat calibration

**NOTE:** Locate thermometer in same position for every calibration. Left front corner of fryer vessel at the High Limit Bulb is recommended.

4. If temperature of fryer is found to be more or less than 15°F off, remove the thermostat knob. There are (4) screws holding the dial plate in place. Loosen the screws and reset the dial plate to match the thermometer reading.

### BEFORE REPLACING, TEST THERMOSTATS

**These operational problems can easily be corrected by thermostat bulb positioning.**

Keating's patented thermostat application is accurate within 2°F of the dial setting between 250°F – 350°F. This accuracy is attained only if the thermostat bulb is placed properly against the heat transfer tube. To quickly and accurately test for proper bulb placement, a single thickness of writing paper should be pulled through between the tube and the bulb with medium resistance.\*

#### 1. \*For gas fryers 14"':

- The end of thermostat bulb should touch the burner tube.

#### 2. For gas fryers 10x11, 18 & up:

- If the bulb is too loose, the paper will slip through with little or no resistance. A fryer with a thermostat bulb that is too loose will overshoot.

*Overshoot:* The thermostat takes a long time to cycle and then misses its preset temperature by 20°F - 40°F yielding a poor quality product.

- If the bulb is too tight, the paper will either not pull through or it will tear. A fryer with a thermostat bulb that is too tight will short cycle.

*Short Cycle:* The thermostat will cycle rapidly while the fryer is in the idle mode; the temperature will be erratic.

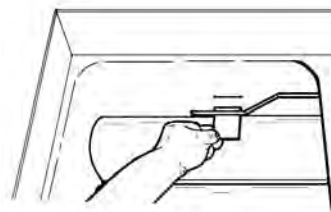

Thermostat Bulb Positioning 10x11, 18 & up Fryer Gas

**REQUIRED TEST EQUIPMENT:**

Multimeter (for testing continuity)

**CHECKING CONTINUITY WITH THE MULTIMETER**

1. Rotate the thermostat shaft until an audible click is heard.
2. Rotate the thermostat shaft left and right ten times causing the switch to click on and off ten times, while using the Multimeter to verify continuity.
3. If the switch does not show continuity during all ten trials, replace the thermostat.

**⚠ WARNING**

Disassembling the thermostat will void the thermostat warranty.

1. Set compression ring onto capillary end of bulb finger tight, 1/2" from end of capillary.
2. Insert new thermostat bulb through control panel back.
3. Apply oil resistant flexible sealant onto compression fitting thread before installing fitting into fryer vessel.
4. Position bent portion of bulb against far right heat transfer tube and install compression fitting snugly into fryer vessel.
5. Adjust bulb so at least 2" of bent portion of it is next to heat transfer tube and tighten compression nut onto compression fitting for fryer 10x11, 18 & up. The end of thermostat bulb should touch the burner tube for 14" fryers.
6. Replace burners.
7. Replace control panel back.
8. Slide back fabric shield over capillary and carefully coil capillary. Avoid crimping.
9. Reconnect wires to thermostat body.
10. Replace two screws which hold thermostat body to control panel.
11. Replace control panel.
12. Replace three retaining screws and washers which hold dial plate in place.
13. Replace thermostat knob.
14. Connect electric power source. Turn on gas and pilots.
15. Boil out fryer.
16. Refill fryer with oil to "fill level line".
17. Start fryer, preheat and calibrate with thermometer.

**"KEATING" ELECTRONIC TIMER  
(PART # 023709)**

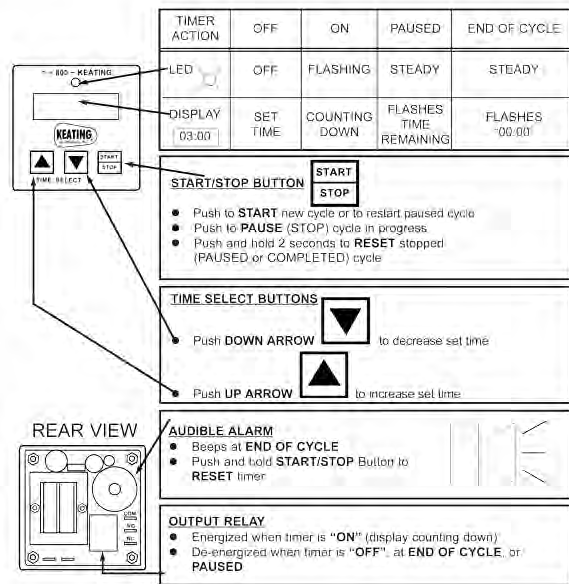

**HOW TO PROGRAM THE "KEATING" ELECTRONIC TIMER**

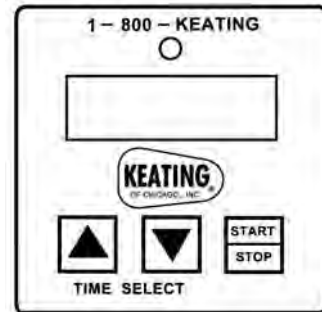

Make certain power to the timer has been OFF for at least 30 seconds. Then PRESS and hold down the UP arrow button while turning the rocker power switch to the ON position.

**Note:** If power switch does not turn off timers, the unit must be unplugged (two people may be needed).

The timer will turn ON and the display will now be indicating

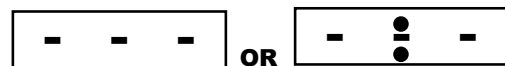

The BEEPER will BEEP 4 times.

If STEP 1 was OK, proceed to STEP 2. If not, retry Step 1 making sure the power was OFF for at least 30 seconds or more.

**STEP 2** PRESS all 3 buttons in sequence: left-center-right. The BEEPER will BEEP when each button is pressed. If BEEPER does not BEEP, the timer is defective. STOP TESTING. Reset procedure is completed when 1:00 appears on the digital display.

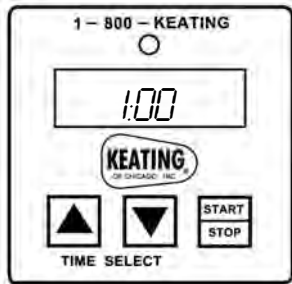

**OPTIONAL TIMER  
OPERATING INSTRUCTIONS  
PART # 056921**

**DIGITAL TIMERS**

The electronic timers, standard on TS & IFM models, provide a clearly visible and accurate display and are very easy to use.



**PROGRAMMING**

To program the timers, the unit must be in the idle mode. Press and hold the set button for approximately two seconds. The display will show "SEt". Press the button for the channel to be programmed. The display will show the current setting for that channel. Use the up or down button to increment or decrement the setting. When the setting is correct, press and hold the set button again for approximately two seconds. The display will show "StO" for approximately two seconds and the timer will return to normal operation. Repeat the process as necessary for the other timers.

**OPERATING LOGIC**

When the timer is powered up, the display will show the time setting for the channel that was operated last and the relay output contacts will be open. To start a cycle, press the desired channel button (1-3). The display will begin to countdown from the preset time setting and the relay output contacts will close. During the countdown the colon will flash at a one-second rate. When the countdown has reached "00:00" the relay output contacts will open, the display will flash, and the audible alarm will sound. To cancel the audible alarm, press any button.

**PAUSE FEATURE**

To pause a cycle in progress, press any button. The relay output contacts will open, the display will flash, and the countdown will pause. To resume the countdown, press any button. The display will resume the normal countdown and the relay output contacts will close.

**CANCELING A CYCLE**

To cancel a cycle in progress press and hold any button for approximately two seconds. The relay output contacts will open and the display will show the time setting for the channel last used.

**WARRANTY REPAIRS**

Keating's warranty begins with the date of installation. In the event that your Fryer, under warranty, needs repairs other than routine cleaning, you are requested to contact KEATING OF CHICAGO, INC. (1-800-KEATING) before calling a local service company.

**ORDERING PARTS**

Parts may be ordered by part number by calling your local service company or Keating at 1-800-KEATING. You may also order on-line at Keating's part store, [www.keatingofchicago.com](http://www.keatingofchicago.com).

Refer to the Keating Gas Fryer Limited Warranty for warranty service information.

The model/serial plate is located on the inside of the front door. The serial and model numbers are necessary when ordering.

**WARNING AND OPERATING PLATES**

All warning and operating plates on the Keating Gas Fryer should be in place at all times.

**PARTS LIST  
CONTROL PANEL AA GAS**

CONTROL PANEL FRONT

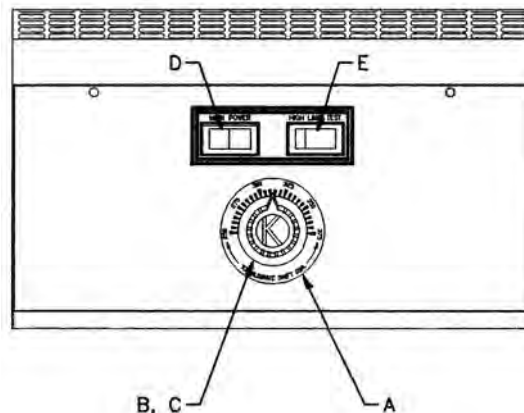

BACK PANEL

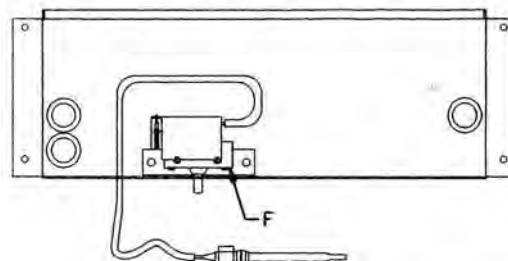

Corresponds with parts list on page 12

QTY.	DESCRIPTION	PART #
A	1 THERMOSTAT DIAL PLATE 375°	058037
B	1 THERMOSTAT KNOB	004163
C	1 GAS FRYER THERMOSTAT 14" 14CM and AA 10x11 18 and up	023145 035553
D	1 SWITCH ROCKER WHITE ON/OFF	035030
E	1 SWITCH ROCKER MOMENTARY	032297
F	1 HIGH LIMIT (RESETTABLE) GAS	034357

### CONTROL PANEL BB GAS

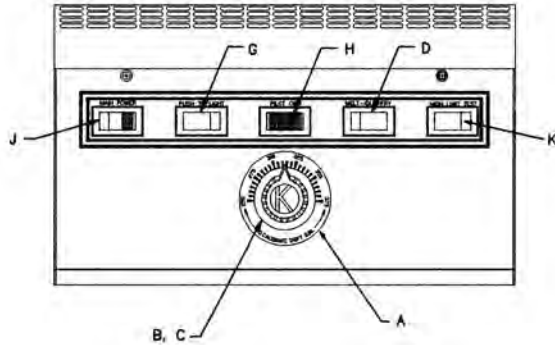

BACK PANEL

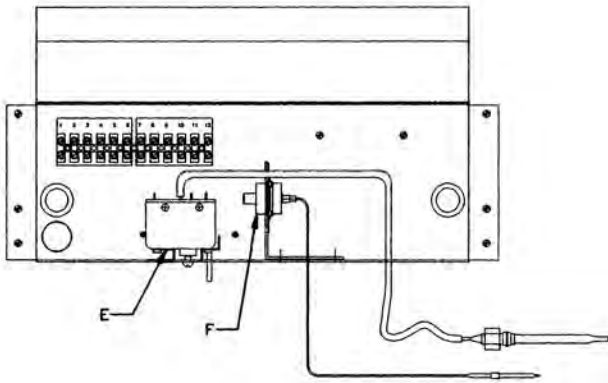

QTY.	DESCRIPTION	P/N
A	1 THERMOSTAT DIAL PLATE 375°	058037
B	1 THERMOSTAT KNOB	004163
C	1 GAS FRYER THERMOSTAT 14" BB, TS, IFM, CPU 10x11, 18" and up	035574 035575
D	1 SWITCH MELT-IDLE-FRY	032829
E	1 HIGH LIMIT (RESETTABLE)	034357
F	1 FLAME SWITCH	037406
G	1 SWITCH ROCKER WHITE MOMENTARY (PUSH TO LIGHT)	032297
H	1 INDICATING LIGHT AMBER	021254
J	1 SWITCH ROCKER WHITE (LIGHT REPLACEMENT KIT)	058328
K	1 SWITCH ROCKER WHITE MOMENTARY (HIGH LIMIT TEST)	032297

### CONTROL PANEL TS GAS

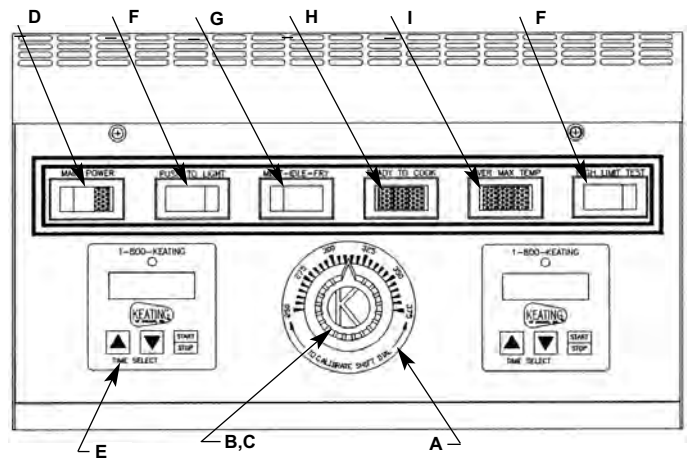

TS CONTROL PANEL

BACK PANEL

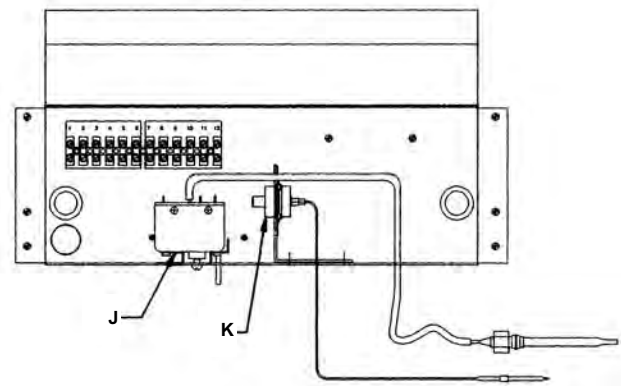

QTY.	DESCRIPTION	P/N
A	1 THERMOSTAT DIAL PLATE 375°	058037
B	1 THERMOSTAT KNOB	004163
C	1 GAS FRYER THERMOSTAT 14" BB, TS, IFM, CPU 10x11, 18" and up	035574 035575
D	1 SWITCH ROCKER WHITE (LIGHT REPLACEMENT KIT)	058328
E	2 DIGITAL TIMER 24V	056921
F	2 SWITCH ROCKER WHITE MOMENTARY (PUSH TO LIGHT, HIGH LIGHT TEST)	032297
G	1 SWITCH MELT/IDLE/FRY	032829
H	1 INDICATING LIGHT GREEN	021255
I	1 INDICATING LIGHT RED	021209
J	1 HIGH LIMIT (RESETTABLE)	034357
K	1 FLAME SWITCH	037406

**ELECTRICAL BOX ASSEMBLY GAS FRYER  
(TS and BB ONLY)**

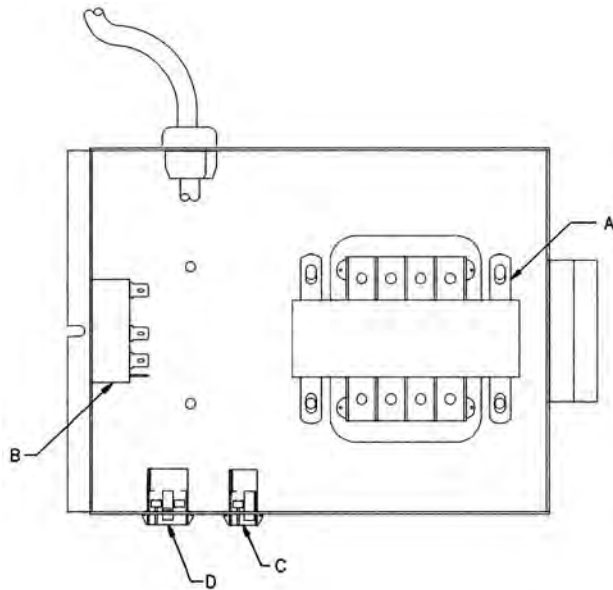

QTY.	DESCRIPTION	P/N
A	1 TRANSFORMER 120V/240V TO 24V	032408
B	1 2 PIN CONNECTOR	032207
C	1 9 PIN CONNECTOR	028303
D	1 FAT MELT 24V	034272

**POT ASSEMBLY 14AA GAS  
(Front Drain Shown)**

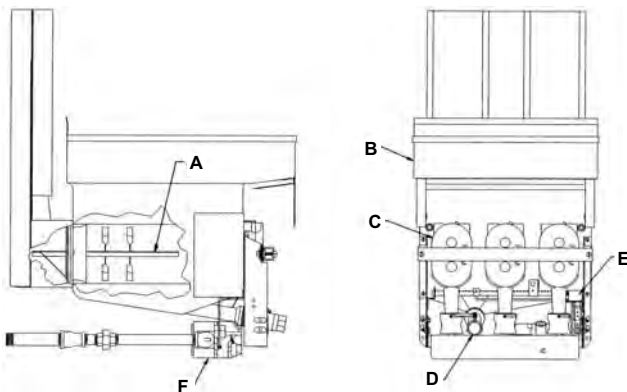

QTY.	DESCRIPTION	P/N
A	3 3 FIN RADIANT	000041
B	1 POT WELDMENT 14" GAS UNI-POT Call 800-KEATING	
C	3 BURNER	028048
D	1 DRAIN VALVE 1"	004553
	1 REAR DRAIN VALVE (NOT SHOWN)	016341
E	1 RUNNER PILOT TUBE ASSEMBLY	019408
F	1 GAS VALVE NAT. LP.	023625 023624

**POT ASSEMBLY 14BB & 14TS GAS  
(Front Drain Shown)**

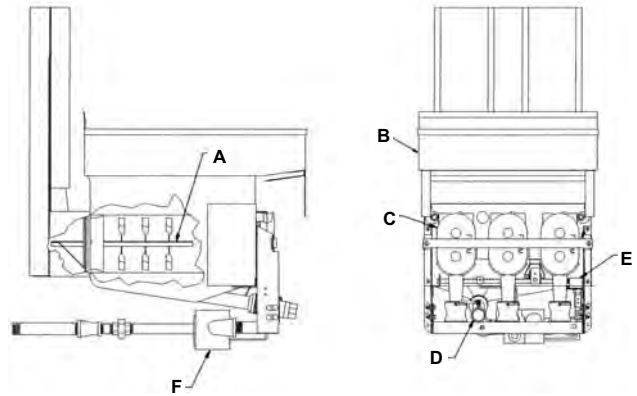

QTY.	DESCRIPTION	P/N
A	3 3 FIN RADIANT	000041
B	1 POT 14" GAS WELDMENT Call 800-KEATING	
C	3 BURNER	028048
D	1 DRAIN VALVE	004553
	1 REAR DRAIN VALVE (NOT SHOWN)	016341
E	1 RUNNER PILOT ASSEMBLY	018814
F	1 GAS VALVE NAT. (FRONT DRAIN TS) LP. (FRONT DRAIN TS)	037237 037238
	1 GAS VALVE NAT. (REAR DRAIN TS) LP.	037241 037242
	1 GAS VALVE NAT. (ALL BB MODELS) LP.	037227 037228

**POT ASSEMBLY 18AA GAS  
(Front Drain Shown)**

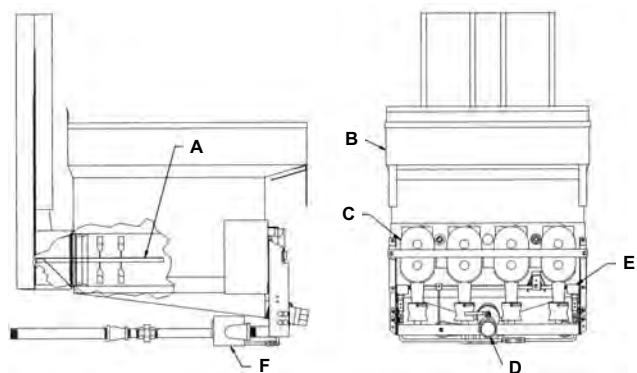

QTY.	DESCRIPTION	P/N
A	4 3 FIN RADIANT	000041
B	1 POT 18" GAS WELDMENT Call 800-KEATING	
C	4 BURNER	028048
D	1 DRAIN VALVE	004554
	1 DRAIN VALVE 2" FRONT	021256
	1 REAR DRAIN VALVE (NOT SHOWN)	016342
E	1 RUNNER PILOT ASSEMBLY	000647
F	1 GAS VALVE NAT. LP.	023625 023624

**POT ASSEMBLY 18BB & 18TS GAS  
(Front Drain Shown)**

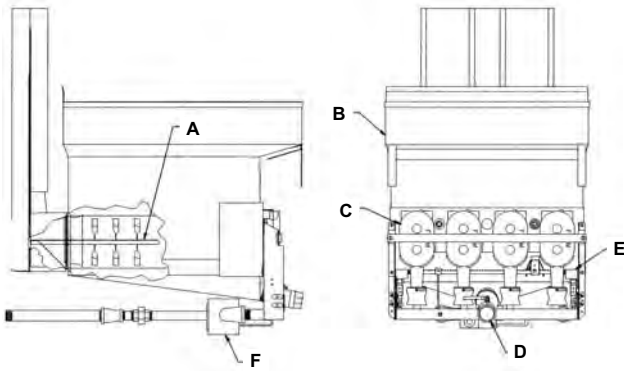

QTY.	DESCRIPTION	P/N
A	4 3 FIN RADIANT	000041
B	1 POT 18" GAS WELDMENT Call 800-KEATING	
C	4 BURNER	028048
D	1 DRAIN VALVE	004554
	1 DRAIN VALVE 2" FRONT	021256
	1 REAR DRAIN VALVE (NOT SHOWN)	016342
E	1 RUNNER PILOT ASSEMBLY	004243
F	1 GAS VALVE NAT. (FRONT DRAIN TS)	037237
	LP. (FRONT DRAIN TS)	037238
	1 GAS VALVE NAT. (REAR DRAIN TS)	037241
	LP.	037242
	1 GAS VALVE NAT. (ALL BB MODELS)	037227
	LP.	037228

**POT ASSEMBLY 20BB & 20TS GAS  
(Front Drain Shown)**

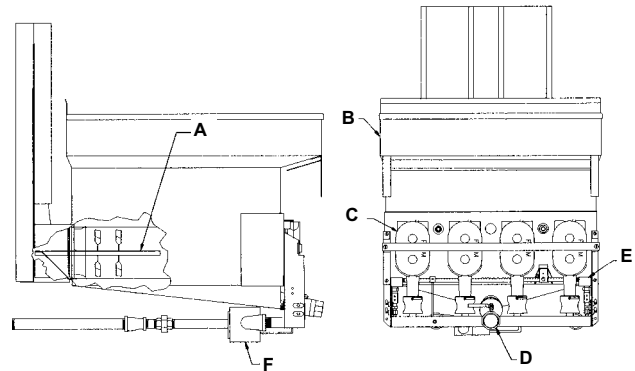

QTY.	DESCRIPTION	P/N
A	4 3 FIN RADIANT	000041
B	1 POT 20" GAS WELDMENT Call 800-KEATING	
C	4 BURNER	028048
D	1 DRAIN VALVE	004554
	1 DRAIN VALVE 2" FRONT	021256
	1 REAR DRAIN VALVE (NOT SHOWN)	016342
E	1 RUNNER PILOT ASSEMBLY	004246
F	1 GAS VALVE NAT. (FRONT DRAIN TS)	037237
	LP. (FRONT DRAIN TS)	037238
	1 GAS VALVE NAT. (REAR DRAIN TS)	037241
	LP.	037242
	1 GAS VALVE NAT. (ALL BB MODELS)	037227
	LP.	037228

**POT ASSEMBLY 20AA GAS  
(Front Drain Shown)**

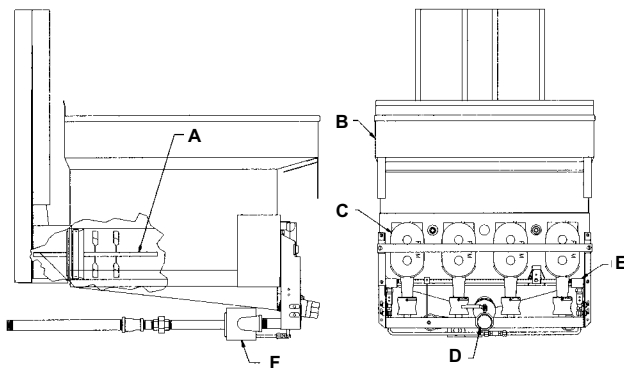

QTY.	DESCRIPTION	P/N
A	4 3 FIN RADIANT	000041
B	1 POT 20" GAS WELDMENT Call 800-KEATING	
C	4 BURNER	028048
D	1 DRAIN VALVE	004554
	1 DRAIN VALVE 2" FRONT	021256
	1 REAR DRAIN VALVE (NOT SHOWN)	016342
E	1 RUNNER PILOT ASSEMBLY	000649
F	1 GAS VALVE NAT.	023625
	LP.	023624

**POT ASSEMBLY 24BB & 24TS GAS  
(Front Drain Shown)**

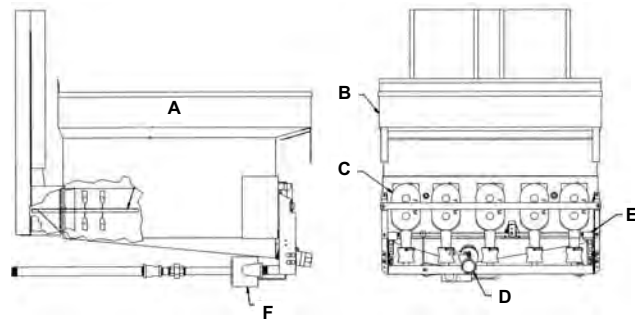

QTY.	DESCRIPTION	P/N
A	5 3 FIN RADIANT	000041
B	1 POT 24" GAS WELDMENT Call 800-KEATING	
C	5 BURNER	028048
D	1 DRAIN VALVE	004554
	1 DRAIN VALVE 2" FRONT	021256
	1 REAR DRAIN VALVE (NOT SHOWN)	016342
E	1 RUNNER PILOT ASSEMBLY	004579
F	1 GAS VALVE NAT. (FRONT DRAIN TS)	037237
	LP. (FRONT DRAIN TS)	037238
	1 GAS VALVE NAT. (REAR DRAIN TS)	037241
	LP.	037242
	1 GAS VALVE NAT. (ALL BB MODELS)	037227
	LP.	037228



### AA2000 ELECTRICAL ASSEMBLY

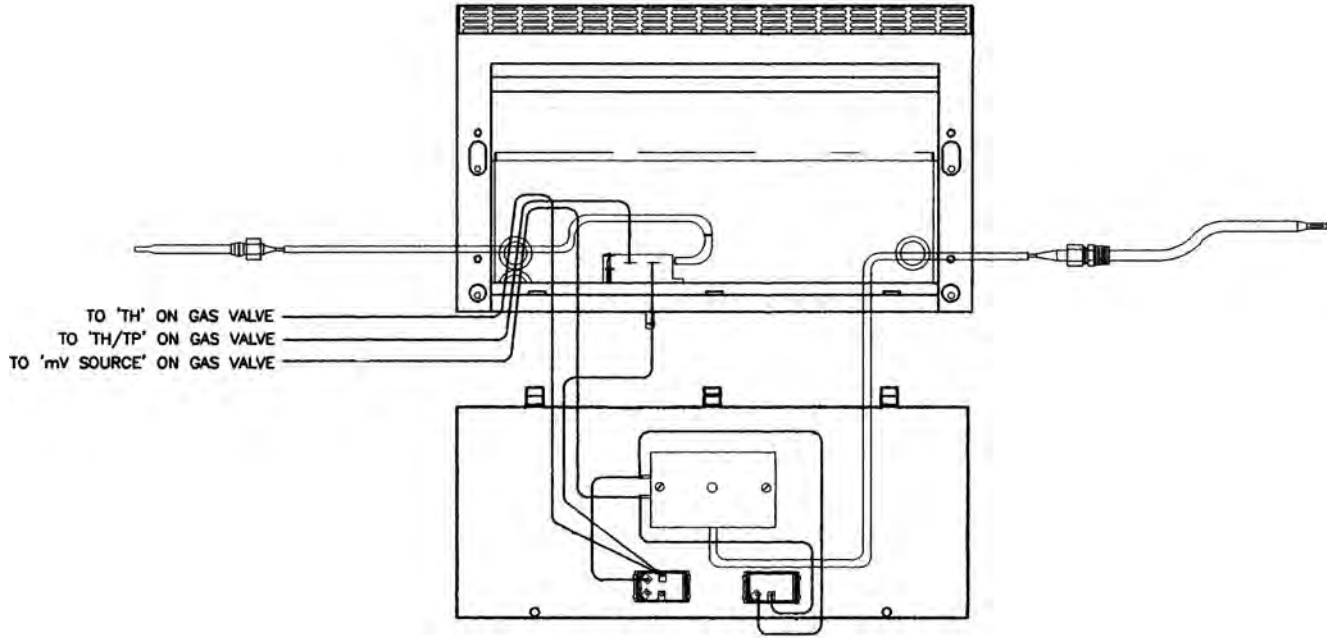

### BB2000 ELECTRICAL ASSEMBLY

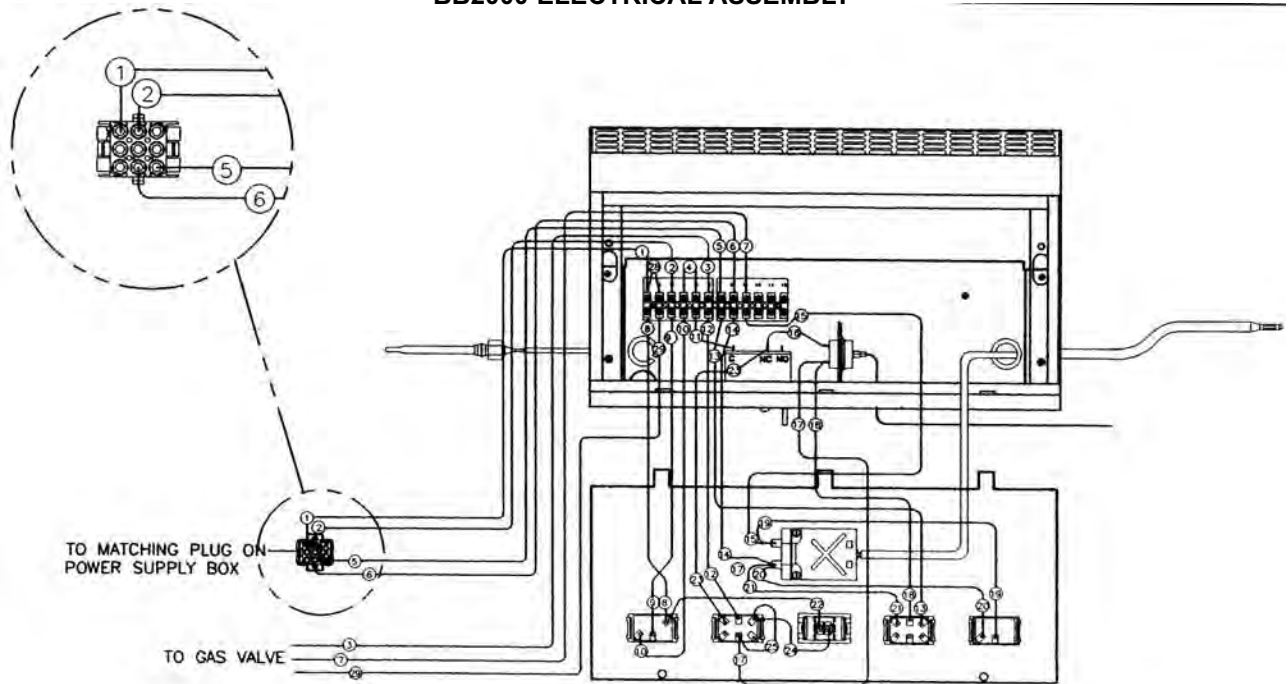

Electrical Assembly not shown to scale  
**TS2000 ELECTRICAL ASSEMBLY**

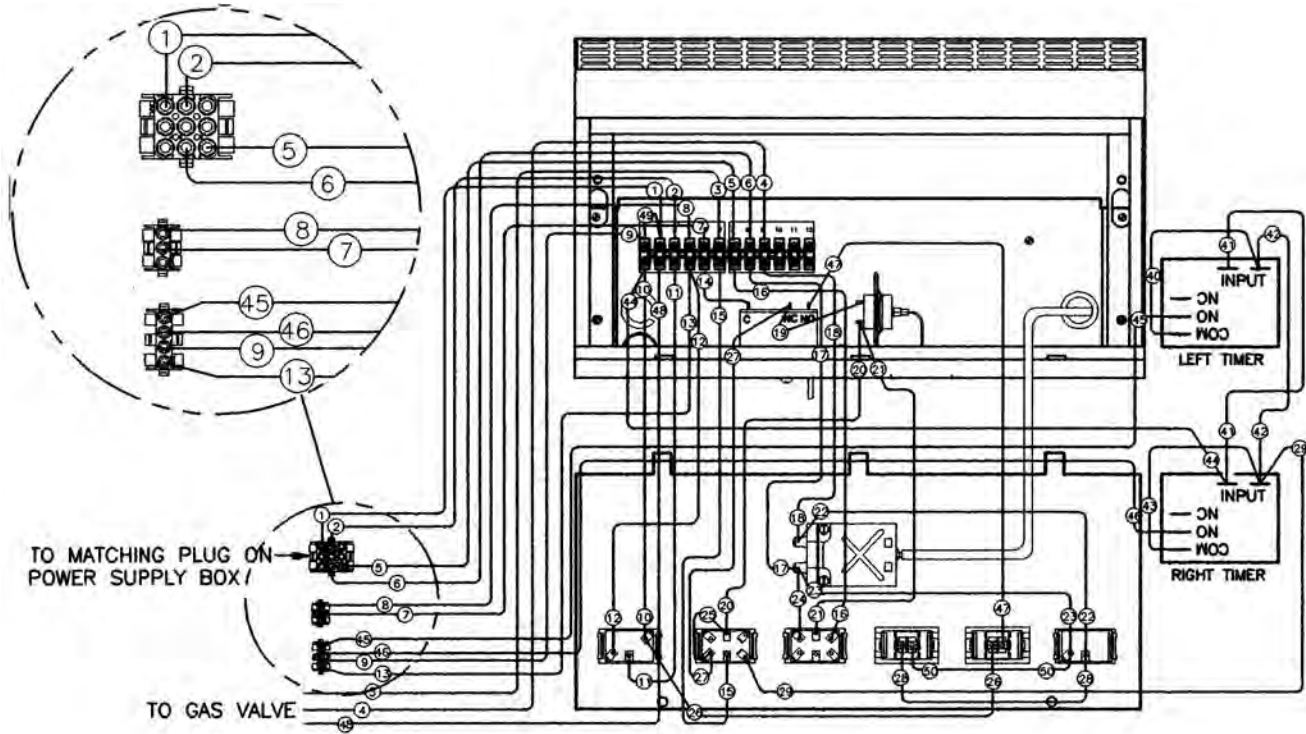

Electrical Assembly not shown to scale

**BB ELECTRICAL ASSEMBLY WITH SE FILTER**

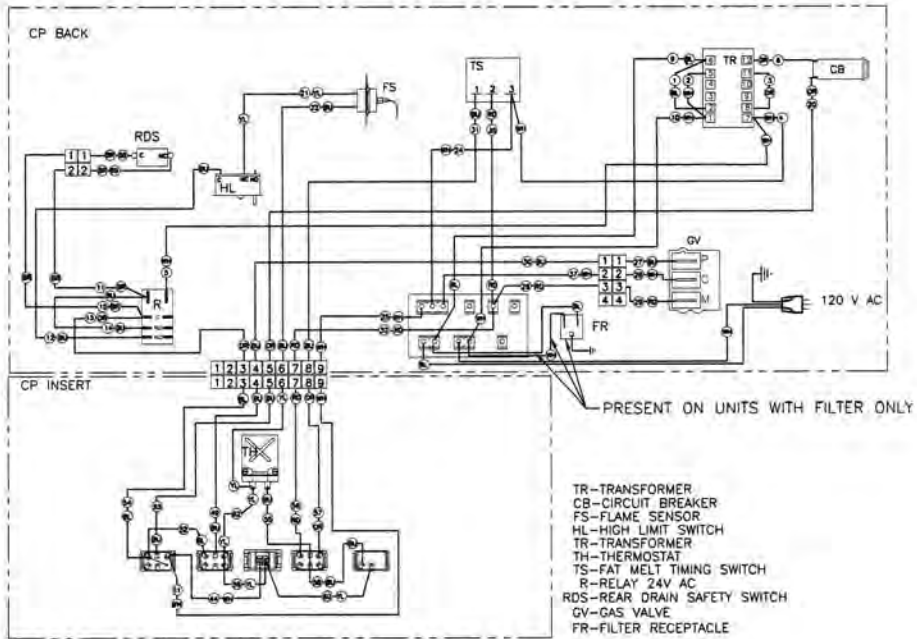

**WIRES COLOR CODE:**

- WH-WHITE
- BL-BLACK
- RD-RED
- BU-BLUE
- BR-BROWN
- OR-ORANGE
- YL-YELLOW
- GR-GREEN

## TS ELECTRICAL ASSEMBLY WITH SE FILTER

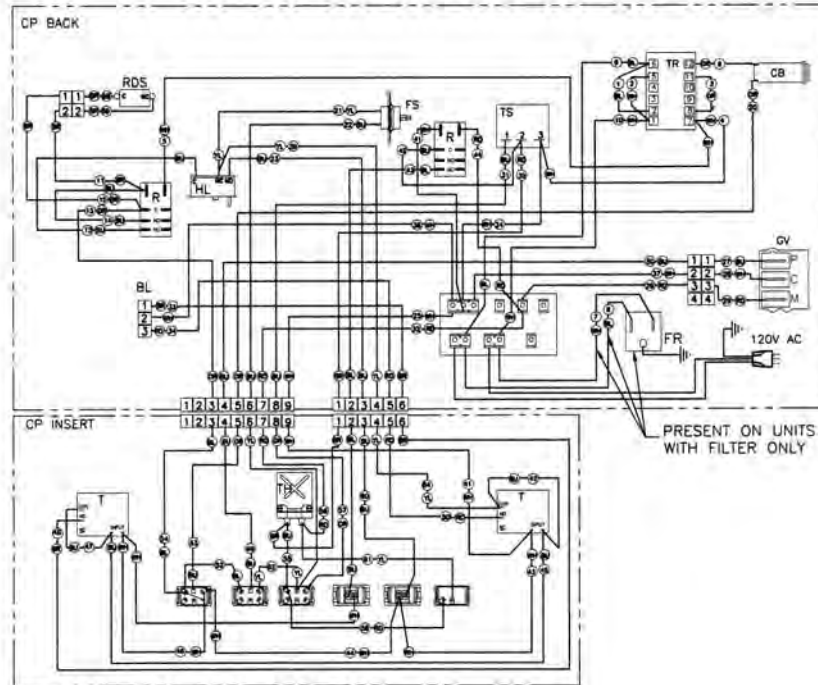

- T-TIMER  
 CB-CIRCUIT BREAKER  
 FS-FLAME SENSOR  
 HL-HIGH LIMIT SWITCH  
 TR-TRANSFORMER  
 TH-THERMOSTAT  
 TS-FAT MELT TIMING SWITCH  
 R-RELAY 24V AC  
 BL-BASKET LIFT CONNECTOR  
 RDS-REAR DRAIN SAFETY SWITCH  
 HL-HIGH LIMIT SWITCH  
 GV-GAS VALVE  
 FR-SE FILTER RECEPTACLE
- WIRES COLOR CODE:  
 WH-WHITE  
 BL-BLACK  
 RD-RED  
 BU-BLUE  
 BR-BROWN  
 OR-ORANGE  
 YL-YELLOW  
 GR-GREEN

PRESENT ON UNITS WITH FILTER ONLY

## BASKET LIFT ELECTRICAL ASSEMBLY (ALL FRYERS)

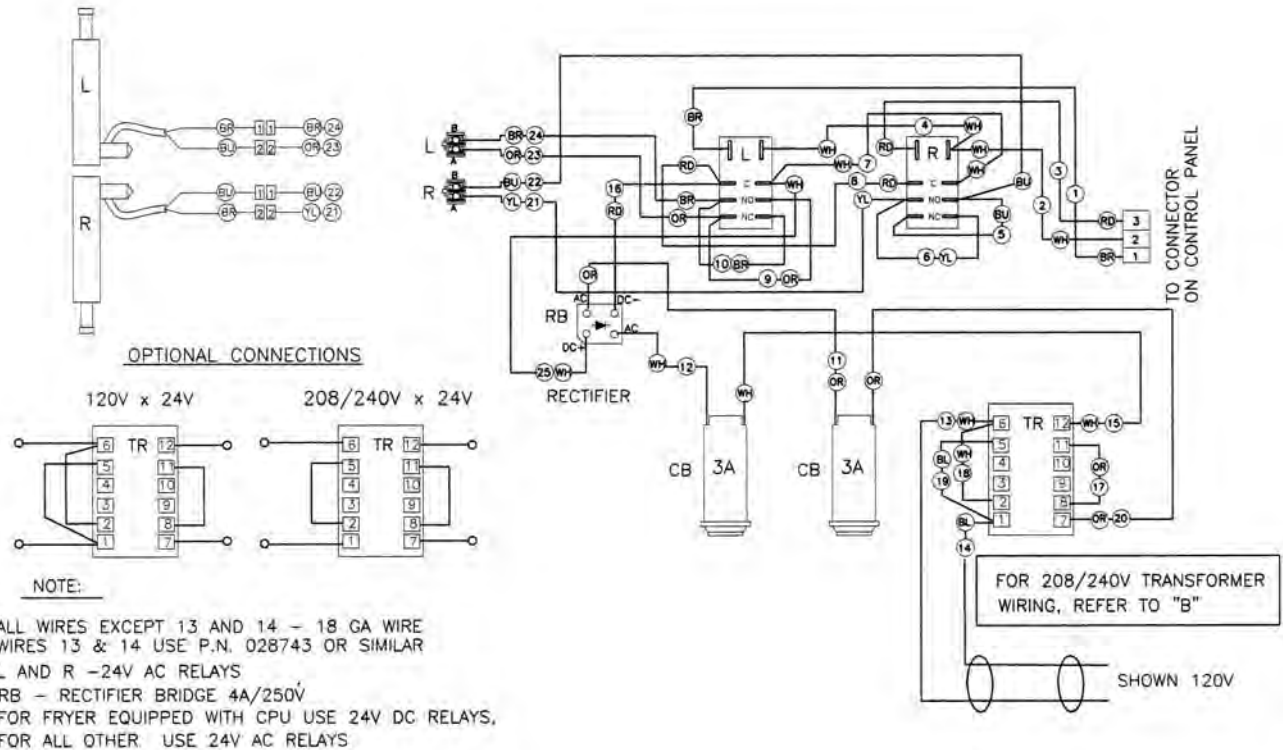

<b>PROBLEM</b>	<b>PROBABLE CAUSE</b>	<b>SOLUTION</b>
Fryer overshoots temperature setting.	<ul style="list-style-type: none"> <li>a. Thermostat bulb improperly placed.</li> <li>b. Thermostat out of calibration.</li> </ul>	<ul style="list-style-type: none"> <li>a. Adjust bulb position. See page 9 – Thermostat Bulb Positioning.</li> <li>b. Calibrate thermostat. See page 9 – Calibration.</li> </ul>
Oil in fryer vessel smokes.	<ul style="list-style-type: none"> <li>a. Oil has begun to breakdown.</li> <li>b. High carbon content in oil.</li> <li>c. Dirty fryer vessel.</li> <li>d. Inferior grade of oil.</li> <li>e. Fryer is overheating.</li> </ul>	<ul style="list-style-type: none"> <li>a. Replace oil.</li> <li>b. Filter oil completely, replace if necessary.</li> <li>c. Boil-out fryer.</li> <li>d. Check with supplier for the grade of oil needed for your cooking applications.</li> <li>e. Check calibration of thermostat (See page 9) and replace if necessary.</li> </ul>
Fryer vessel boiling over.	<ul style="list-style-type: none"> <li>a. Over-filling fryer with oil.</li> <li>b. Product overloaded in fryer vessel.</li> <li>c. Oil breakdown causing foaming.</li> <li>d. Water in the cold zone.</li> </ul>	<ul style="list-style-type: none"> <li>a. Fill fryer up to “Fill Level” Line as oil will expand when heated.</li> <li>b. Follow recommended cooking production figures in determining proper size of loads.</li> <li>c. Replace oil.</li> <li>d. Stir oil repeatedly with a paddle until water boils off. Filter oil. If necessary, allow oil to cool. Drain about one quart of it to remove remaining water.</li> </ul>
Basket lift mechanism will not operate.	<ul style="list-style-type: none"> <li>a. Connections are loose or electronic timer is faulty.</li> <li>b. Motor limit switch is faulty.</li> <li>c. Lift motor is faulty.</li> <li>d. Basket lift relay is faulty.</li> <li>e. Actuator is defective</li> </ul>	<ul style="list-style-type: none"> <li>a. Make sure connections are tight. Replace timer if faulty.</li> <li>b. Replace limit switch or straighten arm.</li> <li>c. Replace motor. Specify left or right side motor when ordering.</li> <li>d. Replace relay.</li> <li>e. Replace Actuator</li> </ul>
Basket lift motor runs, but basket does not move.	<ul style="list-style-type: none"> <li>a. Cam is slipping on motor shaft.</li> </ul>	<ul style="list-style-type: none"> <li>a. Tighten cam onto motor shaft.</li> </ul>
Runner bar will not light	<ul style="list-style-type: none"> <li>a. (For AA units) - gas valve knob in incorrect position.</li> <li>b. (BB and TS units) Hi Limit tripped.</li> </ul>	<ul style="list-style-type: none"> <li>a. Rotate gas valve knob to PILOT position. Depress and hold for 30 seconds.</li> <li>b. Reset High Limit</li> </ul>
Burners with not light	<ul style="list-style-type: none"> <li>a. (For AA units) gas valve knob in incorrect position.</li> <li>b. (BB and TS units) switch not set to fry.</li> </ul>	<ul style="list-style-type: none"> <li>a. Rotate gas valve knob to ON. Turn power switch ON. Set thermostat to desired temperature</li> <li>b. Set MELT/IDLE/FRY switch to FRY. Set thermostat to desired temperature.</li> </ul>



# WARRANTY

## LIMITED WARRANTY

Keating of Chicago, Inc. ("Keating") warrants to the original purchaser. ("Customer"), all new Keating Fryers, Filter Systems, Griddles, Keep Krisp® Custom Pasta Systems, Top-Side™ Cookers, Computer Timers, Fryer & Pasta Vessels and Keating replacement parts ("products") installed after June 1, 1994 to be free to defects in material or workmanship, subject to the following terms and conditions.

## LENGTH OF WARRANTY

All products other than Fryer & Pasta Vessels and replacement parts shall be warranted for a period of one year from the date of original equipment installation. Keating replacement parts are warranted for a period of ninety days from the date of installation. Fryer & Pasta Vessels are warranted as described below.

## FRYER & PASTA VESEL WARRANTY

Fryers purchased after June 1, 1994 carry a prorated vessel warranty on defects in materials or workmanship to the Customer based on the following scale:

Time from Installation Date	Fryer Vessel Warranty Credit
13-60 months	100%
61-72 months	80%
73-84 months	60%
85-96 months	40%
97-108 months	20%
109-120 months	10%

The credit for the defective fryer & pasta vessel shall be applied against the cost of the replacement vessel, utilizing Keating's then current price, upon return of the vessel to Keating, (freight to be paid by Keating within the first 12 months only), only during the first 60 months, subject to the limitations described below.

## LIMITATIONS OF LIABILITY

In the event of warranty claim or otherwise, the sole obligation of Keating shall be the repair and / or replacement at the option of Keating of the product or component or part thereof. Such repair or replacement shall be at the expense of Keating except that the Customer shall pay the following expenses: all freight and labor expense for Keating replacement parts; for all other products, mileage exceeding 50 miles or travel more than one hour, labor costs of more than one person, overtime rates, truck charges, difference between ground and other mode of transportation, and holiday charges. Any repair or replacement under this Limited Warranty does not constitute an extension of the original warranty for any period for the product or for any component or part thereof. Parts to be replaced under this Limited Warranty will be repaired at the option of Keating with new or functionally operative parts. Keep Krisps and Computer Timers must be returned to Keating for warranty repair or replacement. Field repairs of those items are not authorized.

THE LIABILITY OF KEATING ON ANY CLAIM OF ANY KIND, INCLUDING CLAIMS BASED ON WARRANTY, EXPRESSED OR IMPLIED, CONTRACT, NEGLIGENCE, STRICT LIABILITY OR ANY OTHER THEORIES SHALL BE SOLELY AND EXCLUSIVELY THE REPAIR OR REPLACEMENT OF THE PRODUCT AS STATED HEREIN, AND SUCH LIABILITY SHALL NOT INCLUDE, AND CUSTOMER SPECIFICALLY RENOUNCES ANY RIGHTS TO RECOVER, SPECIAL, INCIDENTAL, CONSEQUENTIAL OR OTHER INJURIES TO PERSONS OR DAMAGE TO PROPERTY, LOSS OF PROFITS OR ANTICIPATED PROFITS, OR LOSS OF USE OF THE PRODUCT.

If any oral statements have been made regarding the Keating products, such statements do not constitute warranties and are not part of the contract sale. This Limited Warranty constitutes the complete, final and exclusive statement with regard to warranties.

THIS LIMITED WARRANTY IS EXCLUSIVE AND IS IN LIEU OF ALL OTHER WARRANTIES WHETHER WRITTEN, ORAL, STATUTORY OR IMPLIED, INCLUDING BUT NOT LIMITED TO ANY WARRANTY OF MERCHANTABILITY OR FITNESS FOR PARTICULAR PURPOSE OR WARRANTY AGAINST LATENT DEFECTS.

## EXCLUSIONS

The warranties provided by Keating of Chicago, Inc. do not apply in the following instances:

1. Defects arising out of or resulting from improper installation or maintenance, abuse, misuse, modification or alteration by unauthorized service personnel, or any other condition not attributable to a defect in material or workmanship. Proper installation and maintenance are the responsibility of the installer and Customer, respectively. Proper installation and maintenance procedures are prescribed by the Keating Service Manual.
2. In the event that the product was damaged after leaving the factory due to flood, fire, other acts of God or accident, damage during shipment should be reported to the carrier and is not the responsibility of Keating.
3. In the event the serial number or rating plate has been removed from the product or altered.
4. On parts which would normally be worn or replaced under normal conditions, including but not limited to electric bulbs, fuses, interior and exterior finishes, gaskets and radiants.
5. With regard to adjustments and calibrations such as leveling, tightening of fasteners or plumbing connections, improper gas pressure or improper electrical supply, the checking of and changes in adjustment and calibrations are the responsibility of the installer. Proper installation procedures are prescribed by the Keating Service Manual.
6. In the event of unauthorized repairs or alterations to the Keating product.
7. With the use of sodium chloride in pasta vessels or harsh chemicals in fryer or pasta vessels.
8. Installation in Household.

## OTHER TERMS AND CONDITIONS

The Customer must provide proof of purchase from Keating.

This Limited Warranty is valid in the 50 United States, its territories, and Canada, and is void elsewhere.

Keating products are sold for commercial use only. If any Keating product is sold as a component of another product or used as a consumer product, such Keating product is sold As Is without any warranty.

If any provision of this Limited Warranty is held to be unenforceable under the law of any jurisdiction, such provision shall be inapplicable in such jurisdiction, and the remainder of the warranty shall remain unaffected. Further in such event, the maximum exclusion or limitation allowable under applicable law shall be deemed substituted for the unenforceable provision.

This Limited Warranty shall be governed by and construed in accordance with the laws of the State of Illinois.

## TO SECURE WARRANTY SERVICE

All repair services under this Limited Warranty must be authorized by Keating or performed at Keating. Authorization may be obtained by calling 1-800-KEATING within the Continental United States, Alaska, Hawaii, Puerto Rico and Canada during normal business hours (8 a.m. through 5 p.m. Central Time, Monday through Friday). When calling, please have the following information available: (1) name, address and telephone number of the Customer; (2) location of product, if different; (3) name, model number and serial number of the product; (4) installation date; and (5) description of defect. Keating will then issue a service authorization work order number to one of its approved independent servicing organizations, or request the product or part be shipped to Keating for repair or replacement, as appropriate. Any defective part subject to a claim under this Limited Warranty must be shipped freight prepaid to Keating for testing and examination. Keating's decision as to the cause and nature of any defect under this Limited Warranty shall be final.

**SERVICE INFORMATION**

If you have a service related question call 1-800-KEATING.  
Please state the nature of the call; it will ensure speaking with the appropriate person.  
Have your serial and model number available when ordering parts.

**KEATING OF CHICAGO, INC.**

8901 West 50th Street, McCook, Illinois 60525-6001  
Phone: (708) 246-3000 FAX: (708) 246-3100  
Toll Free 1-800-KEATING (In U.S. and Canada)  
www.keatingofchicago.com

**KEATING LIMITED WARRANTY CARD**

PLEASE COMPLETE AND MAIL AT ONCE—WARRANTY IS NOT IN EFFECT UNTIL CARD IS RETURNED.  
WARRANTY CARD IS ALSO AVAILABLE TO COMPLETE ON LINE AT YOUR CONVENIENCE.

COMPANY: \_\_\_\_\_

ADDRESS: \_\_\_\_\_

CITY: \_\_\_\_\_ STATE: \_\_\_\_\_ ZIP: \_\_\_\_\_

DEALER: \_\_\_\_\_

DATE OF PURCHASE: \_\_\_\_\_ INVOICE NUMBER: \_\_\_\_\_

SERIAL NUMBER: \_\_\_\_\_  FRYER  FILTER SYSTEM  GRIDDLE

REMARKS: \_\_\_\_\_  TOP-SIDE COOKER  HOT PLATE  PASTA PLUS

I HAVE READ THE INSTALLATION AND OPERATION INSTRUCTIONS.

SIGNED: \_\_\_\_\_ DATE: \_\_\_\_\_