

# Crestron **CHV-TSTAT & CHV-THSTAT** Thermostats

---

## Operations and Installation Guide



**CRESTRON**

This document was prepared and written by the Technical Documentation department at:



Crestron Electronics, Inc.  
15 Volvo Drive  
Rockleigh, NJ 07647  
1-888-CRESTRON

# Contents

|                                                          |          |
|----------------------------------------------------------|----------|
| Quick Installation Reference .....                       | ii       |
| <b>Thermostats: CHV-TSTAT and CHV-THSTAT</b>             | <b>1</b> |
| Introduction .....                                       | 1        |
| Functions and Features .....                             | 1        |
| Specifications .....                                     | 3        |
| Physical Description .....                               | 4        |
| Industry Compliance .....                                | 6        |
| Setup .....                                              | 7        |
| Network Wiring .....                                     | 7        |
| Identity Code .....                                      | 7        |
| System Connections .....                                 | 8        |
| Wiring Diagrams .....                                    | 9        |
| Separately Powered (by an independent transformer) ..... | 9        |
| Three-Wire Heating System Connections .....              | 10       |
| Five-Wire Heating/Cooling System Connections .....       | 11       |
| Heat Pump Connections (Single & Two-Stage) .....         | 12       |
| Installation .....                                       | 14       |
| Thermostat Setup and Operation .....                     | 16       |
| Setup Procedure .....                                    | 16       |
| Operating the Thermostat .....                           | 21       |
| Programming Software .....                               | 24       |
| Programming with Crestron D3 Pro .....                   | 25       |
| Programming with SIMPL Windows .....                     | 25       |
| Viewport ID String .....                                 | 36       |
| Problem Solving .....                                    | 37       |
| Troubleshooting .....                                    | 37       |
| Further Inquiries .....                                  | 38       |
| Firmware Upgrades .....                                  | 38       |
| Future Updates .....                                     | 38       |
| Appendix A: Glossary .....                               | 39       |
| Appendix B: About Heat Pumps .....                       | 40       |
| Return and Warranty Policies .....                       | 41       |
| Merchandise Returns / Repair Service .....               | 41       |
| CRESTRON Limited Warranty .....                          | 41       |

## Quick Installation Reference

1. Select a suitable location and run the connecting wires from the heating/cooling system and the Cresnet system. Refer to page 5 for a description of the thermostat connectors. Refer to page 7 for Network wiring details. Use the appropriate wiring diagram:
  - Heating or Cooling System Powered (Refer to page 9).
  - Separately Powered (Refer to page 9).
  - Three Wire Heat Only with Fan (Refer to page 10).
  - Five Wire Heat/Cool Systems (Refer to page 11)
  - Single Stage and Two Stage Heat Pump (Refer to page 12).
2. Separate the thermostat from the backplate to expose the connections and mounting holes.
3. Mount the thermostat backplate (60 inches above the finished floor) directly to the wall with wall anchors (not provided) and screws (not provided) or to a single-gang box (not provided) mounted horizontally, and connect the wiring. Refer to page 14 for detailed mounting instructions and page 8 for detailed connector information. If using a five-sided box, fill with insulation material to minimize wall air ingress.
4. Install the thermostat on the backplate (Refer to page 14).
5. Setup the thermostat (Refer to page 16).
6. Configure the thermostat (Refer to Operating the Thermostat on page 21).

# Thermostats: CHV-TSTAT and CHV-THSTAT

---

## Introduction

### Functions and Features

The CHV-TSTAT and CHV-THSTAT series are wall-mounted universal thermostats that can be part of a Crestron Home<sup>®</sup> total control system. The thermostats are capable of controlling one or two-stage heating and cooling systems. Each thermostat is available in three colors: almond, black and white. The suffix 'A', 'B', and 'W', respectively denotes color, e.g., CHV-TSTATB is a black unit. For simplicity within this guide, color suffix is omitted and the designations CHV-TSTAT and CHV-THSTAT are used except where noted.

#### *Functional Summary*

- User adjustable temperature and/or humidity control of one and two-stage heating and cooling systems
- 128 x 64 transfective 2.75 inch (6.99 cm) LCD display
- Fahrenheit or Celsius indication
- Four-front panel buttons for setup, configuring and temperature/humidity adjustments
- Back light (with each button press) for night viewing
- Supports up to two remote temperature and/or temperature/humidity sensors. Future firmware releases will support up to four remote sensors per thermostat
- Operates as a stand-alone device or in a Cresnet<sup>®</sup> system
- Extended functionality as a Cresnet device for lighting control, alarms, etc.

The CHV-TSTAT provides temperature control, while the CHV-THSTAT provides temperature and humidity control. Temperature and humidity information is provided through a transfective LCD display. Four front panel buttons and the LCD display provide temperature and/or humidity indication and control, current system status, and current fan mode. The LCD also provides status indicators denoting when heat, cool, humidity or fan outputs are energized; a message indicator, so users know when a message is waiting to be read; a net indicator to denote when the network is active and a hold indicator that identifies when the thermostat is overriding the Cresnet temperature set point commands.

### **Remote Sensors**

The current firmware release supports the addition of two optional remote sensors: temperature only (CHV-RTS) and/or temperature/humidity (CHV-RTHS), for both thermostats.

Outdoor conditions can be imported from the optional external sensors CHV-RTS or CHV-RTHS, temperature and temperature/humidity respectively.

Subsequent firmware releases will support the addition of up to four optional remote sensors, in any combination, for each thermostat. For additional information about the sensors, refer to the latest revision of the CHV-RTS & CHV-RTHS Installation Guide (Doc. 8189), which is available from the Crestron website ([www.crestron.com](http://www.crestron.com)).

---

**NOTE:** The CHV-TSTAT and CHV-THSTAT allow the user to set a temperature that the heating and/or cooling system maintains. This is called the “Set Point”. Refer to “Operating the Thermostat” on page 21 for more information.

**NOTE:** Crestron sensors are suitable for mounting in dry or damp locations as defined by the National Electrical Code.

**NOTE:** Installers should have a strong working knowledge of HVAC systems.

---

### **Heating and Cooling Systems**

The CHV-TSTAT can control the following heating and cooling systems:

- One stage heat
- One stage heat, one stage cool
- One stage heat, one stage cool: heat pump with auxiliary heat
- Two stage heat
- Two stage heat, one stage cool
- One stage heat, two stage cool
- Two stage heat, two stage cool
- Two stage heat, two stage cool: heat pump with auxiliary heat

---

**NOTE: Two Stage Heating** – Unlike traditional furnaces that turn on and run at full capacity with each demand for heating, two-stage heat operates like two separate furnaces to maintain more consistent comfort in your home. The unit starts out running in its first stage, and operates at a fraction of its heating capacity. This reduced capacity is sufficient to warm your home on mild winter days. But when the temperature outside goes very low, the furnace adjusts to full capacity (second stage) to meet the demand for heat within the home.

**Two Stage Cooling** – In warm weather, the first stage of the cooling equipment operates at a fraction of the total cooling capacity. On very hot days, the second stage of the cooling equipment energizes, and the cooling system operates at full capacity.

---

## Specifications

The following table provides a summary of specifications for the CHV-TSTAT and CHV-THSTAT.

### *CHV-TSTAT and CHV-THSTAT Specifications*

| SPECIFICATION                                                | DETAILS                                                                                                       |
|--------------------------------------------------------------|---------------------------------------------------------------------------------------------------------------|
| Power Requirements                                           | 2 Watts (24 VAC @ 83mA) Heating or Cooling System Supplied                                                    |
| Crestron power factor                                        | <1Watt (required for Cresnet communication only)                                                              |
| Default Network ID                                           | 2A                                                                                                            |
| Control System Update Files <sup>1,2,3</sup>                 |                                                                                                               |
| 2-Series Control System                                      | Version C2-2004.CUZ or later                                                                                  |
| CEN/CN-TVAV                                                  | Version 5.10.13V.UPZ or later                                                                                 |
| CNMSX-AV/PRO                                                 | Version 5.07.05X.UPZ or later                                                                                 |
| CNRACKX/-DP                                                  | Version 5.07.06W.UPZ or later                                                                                 |
| ST-CP                                                        | Version 4.00.49S.UPZ or later                                                                                 |
| LCD Display                                                  | 128 x 64 Transflective 2.75 in (6.99 cm)                                                                      |
| Screen Viewing Angles                                        | Y Dir. (X=0°): +50° (from top) –50° (from bottom)<br>X Dir. (X=10°): +50° (from right) –50° (from left)       |
| Humidity Range                                               | 0 – 100%                                                                                                      |
| Auto Setpoint Range (union of heat and cool setpoint ranges) | 38 –99°F (3 – 37°C)                                                                                           |
| Heat Only Setpoint Range                                     | 38 – 89°F (3 – 32°C)                                                                                          |
| Cool Only Setpoint Range                                     | 59 – 99°F (15 – 37°C)                                                                                         |
| Temperature Measurement Range                                | 0 – 110° (-18 – 43°C)                                                                                         |
| Firmware Update Files <sup>4</sup>                           |                                                                                                               |
| CHV-TSTAT/CHV-THSTAT Update Files                            | CHVTSTAT.xx.UPG or later<br>CHVTHSTAT.x.x.UPG or later                                                        |
| Dimensions and Weight                                        | Height: 3.75 in (9.50 cm)<br>Width: 5.00 in (12.70 cm)<br>Depth: 1.04 in (2.63 cm)<br>Weight: 5.80 oz (165 g) |

1. The latest versions can be obtained from the Downloads | Software Updates section of the Crestron website ([www.crestron.com](http://www.crestron.com)). Refer to NOTE after last footnote.
2. Crestron 2-Series control systems include the AV2, CP2, CP2E, MP2, MP2E, PAC2, PRO2, and RACK2.
3. CNX update files are required for either CNMSX-AV/Pro or CNRACKX/-DP. Filenames for CNX update files have a UPZ extension and ST-CP files are in one EXE or zipped UPZ file. To avoid program problems, make certain you are using the update file with the correct suffix letter (e.g., S, V, W, X).
4. Filenames for CHV update files have a UPG extension and are in one zipped UPG file. The 'x' in the file name refers to the version number.

**NOTE:** Crestron software and any files on the website are for Authorized Crestron dealers only. New users may be required to register to obtain access to certain areas of the site (including the FTP site).

### Physical Description

Refer to the illustrations below and on next page. The CHV-TSTAT and CHV-THSTAT are enclosed in a plastic enclosure with four buttons and an LCD display on the front. The back of the unit has ventilation slots, and holes for mounting the unit and wiring. The ventilation slots must be unobstructed for airflow to the unit.

*Physical View of CHV-TSTAT and CHV-THSTAT*

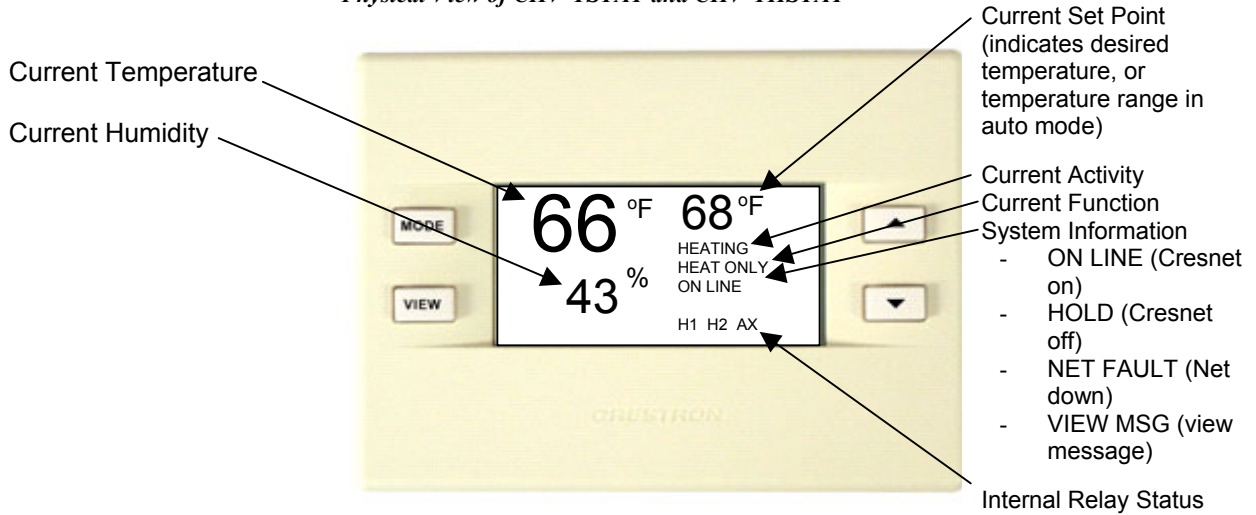

*Front and Side Views*

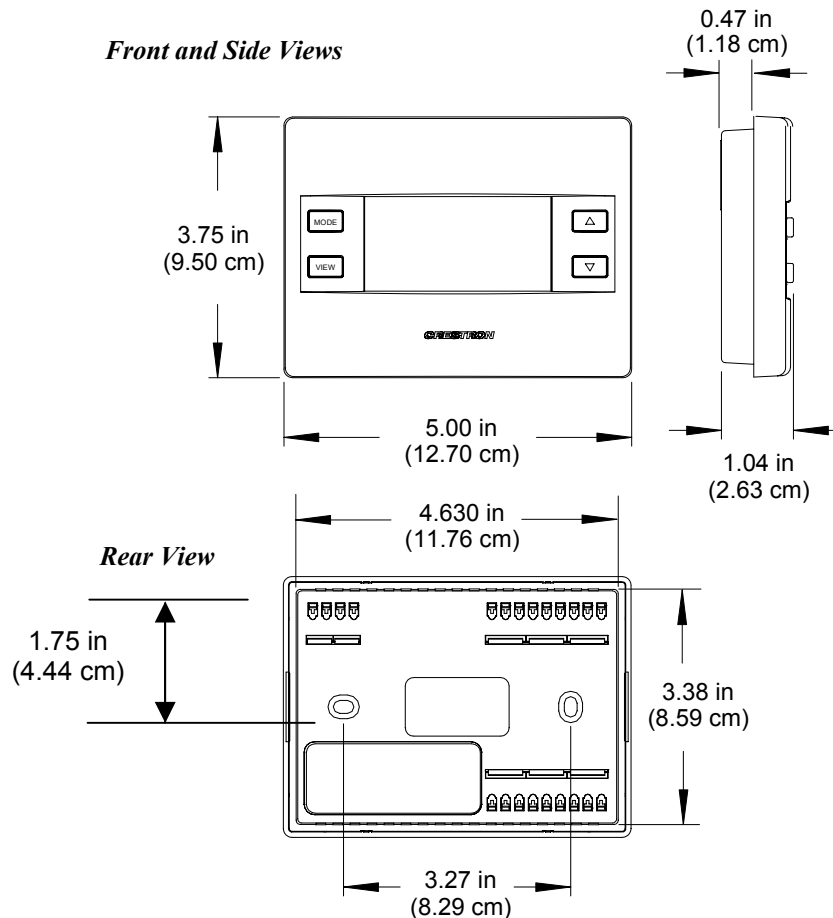



*Connection View (Backplate, view from the front with cover removed)*

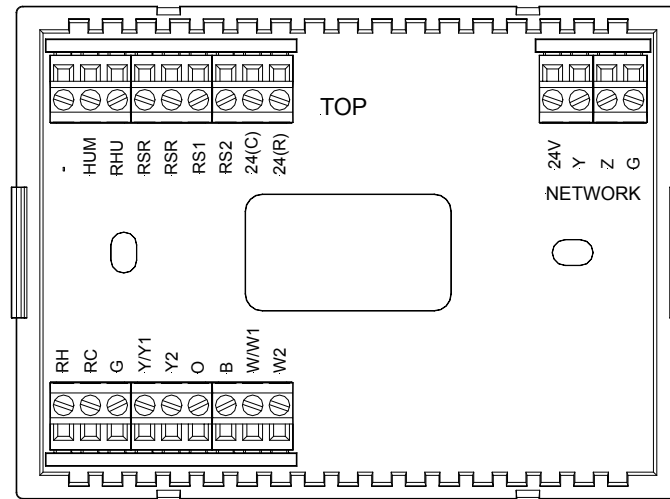

**Ports**

The CHV-TSTAT and CHV-THSTAT have four types of connections on the inside back plate (refer to graphic above).

NETWORK (Optional) – provides communication to the control system and Cresnet power to the CHV-TSTAT and CHV-THSTAT. If making network connections to Cresnet peripherals, refer to “Network Wiring” on page 7.

**CRESNET CONNECTIONS (optional)**

| PIN | DESCRIPTION  |
|-----|--------------|
| 24  | +24VDC       |
| Y   | Cresnet Data |
| Z   | Cresnet Data |
| G   | Ground       |

**REMOTE SENSING CONNECTIONS (optional)**

| PIN | DESCRIPTION                                                 |
|-----|-------------------------------------------------------------|
| RSR | Remote Sensor Returns – Common sensor terminal              |
| RS1 | Remote Sensor terminal – Connect the sensor from RS1 to RSR |
| RS2 | Remote Sensor terminal – Connect the sensor from RS2 to RSR |

**POWER CONNECTIONS (Required)**

| PIN    | DESCRIPTION (refer to System Connections on page 8)                                                                                                    |
|--------|--------------------------------------------------------------------------------------------------------------------------------------------------------|
| 24 (C) | 24 VAC common terminal supplies remote 24 VAC power to thermostat.                                                                                     |
| 24 (R) | 24 VAC reference terminal. Can be connected to RH or RC by P4 jumper setting, or tied directly to power source (refer to System Connections on page 8) |

**CONTROL CONNECTIONS** (System Dependent)

| PIN  | DESCRIPTION                                                                                                                       |
|------|-----------------------------------------------------------------------------------------------------------------------------------|
| HUM  | Energized to RHU during humidity call                                                                                             |
| RHU  | Reference for humidifier                                                                                                          |
| RH   | Reference Heat, used for calls to heating system                                                                                  |
| RC   | Reference Cool, used for calls to cooling system                                                                                  |
| G    | Fan, energized to RC during call for fan                                                                                          |
| Y/Y1 | Compressor (stage one), energized to RC when compressor (or first stage) is run                                                   |
| Y2   | Compressor (stage two), energized to RC on two-stage systems on call for second stage                                             |
| O    | Changeover control, energized to RC during cooling modes                                                                          |
| B    | Energized to RC during non-cooling modes                                                                                          |
| W/W1 | Heat (single stage)/heat (stage one) energized to RH during a call for heat in heat/cool systems or aux heat in heat pump systems |
| W2   | Heat (stage two), energized to RH during a call for second stage heat in heat/cool systems                                        |

**Buttons**

There are four buttons used to setup and adjust the thermostat.



**MODE** – Access to the user controls (System Mode, Fan Mode, Humidifier, Crestron System, and Global Update)



**VIEW** – Access to Humidity reading, Outdoor Temperature reading, and System Messages.

---

**NOTE:** When **MODE** and **VIEW** are pressed together and held for five seconds, the thermostat enters the system setup mode (refer to “Thermostat Setup” on page 16).

---



**UP ▲** – Selects user modes and increments selection in setup modes



**DOWN ▼** – Selects user modes and decrements selection in setup modes

**Industry Compliance**

As of the date of manufacture, this unit has been tested and found to comply with specifications for CE marking and standards per EMC and Radio Communications Compliance Labeling (N11785).



---

**NOTE:** This device complies with part 15 of the FCC rules. Operation is subject to the following two conditions: (1) this device may not cause harmful interference, and (2) this device must accept any interference received, including interference that may cause undesired operation.

---

## Setup

### Network Wiring

**NOTE:** When installing network wiring, refer to the latest revision of the wiring diagram(s) appropriate for your specific system configuration, available from the Downloads | Product Manuals | Wiring Diagrams section of the Crestron website ([www.crestron.com](http://www.crestron.com)).

When calculating the wire gauge for a particular Cresnet run, the length of the run and the power factor of each network unit to be connected must be taken into consideration. If Cresnet units are to be daisy-chained on the run, the power factor of each unit to be daisy-chained must be added together to determine the power factor of the entire chain. If the unit is a home-run from a Crestron system power supply network port, the power factor of that unit is the power factor of the entire run. The length of the run in feet and the power factor of the run should be used in the following resistance equation to calculate the value on the right side of the equation.

#### Resistance Equation

$$R < \frac{40,000}{L \times PF}$$

Where: R = Resistance (refer to table below).  
L = Length of run (or chain) in feet.  
PF = Power factor of entire run (or chain).

The required wire gauge should be chosen such that the resistance value is less than the value calculated in the resistance equation. Refer to the table below.

#### Wire Gauge Values

| RESISTANCE | WIRE GAUGE    |
|------------|---------------|
| 4          | 16            |
| 6          | 18            |
| 10         | 20            |
| 15         | 22            |
| 13         | Doubled CAT 5 |
| 8.7        | Tripled CAT 5 |

**NOTE:** All Cresnet wiring must consist of two twisted-pairs. One twisted pair is the +24V conductor and the GND conductor and the other twisted pair is the Y conductor and the Z conductor.

**NOTE:** For larger networks (i.e., greater than 28 network devices), it may be necessary to add a Cresnet Hub/Repeater to maintain signal quality throughout the network. Also, for networks with lengthy cable runs or varying types of network devices, it may be desirable to add a hub/repeater after only 20 network devices.

### Identity Code

Every equipment and user interface within the network requires a unique Cresnet identity code (NET ID). These codes are assigned a two-digit hexadecimal number from 03 to FE. The NET ID of the unit must match the NET ID specified in the SIMPL Windows or D3 Pro program. Refer to “Device Options” on page 18 for a description of assigning the NET ID to the thermostat and “Setting the Net ID in Device Settings” on page 26 for an example of the SIMPL Windows procedure.

### System Connections

*Backplate - view from the front with the cover removed*

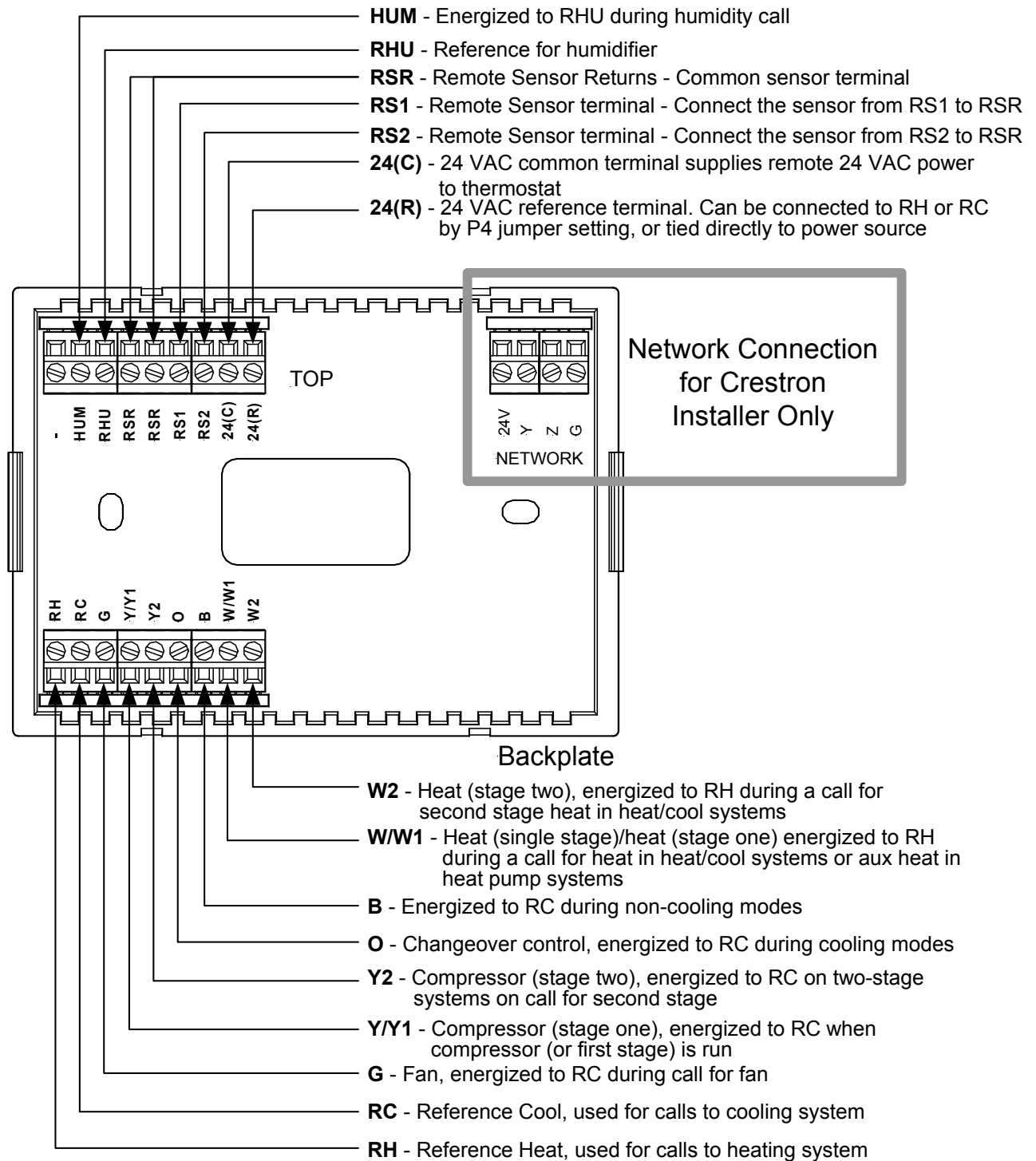

# Wiring Diagrams

The wiring diagrams that follow show connections for the CHV-TSTAT and CHV-THSTAT.

**CAUTION:** The P4 Jumper Position on the Circuit Board depends on the power method chosen, and is critical to proper operation. Improper P4 jumper position can cause equipment damage.

**NOTE:** Ensure that the power circuits are shut off at the source before connecting the thermostat. Provide disconnect means and overload protection as required for the power supply.

**NOTE:** Ensure that the transformer has sufficient power for all the thermostats in the system, or use multiple transformers. Refer to the power requirements in “Specifications” on page 3.

The following diagrams are examples of connections for heat, heat/cool and one-stage and two-stage heat pump systems.

**NOTE:** Use either connector O or B as required, for changeover control.

## Separately Powered (by an independent transformer)

*Backplate Connection and Circuit Board Jumper Position*

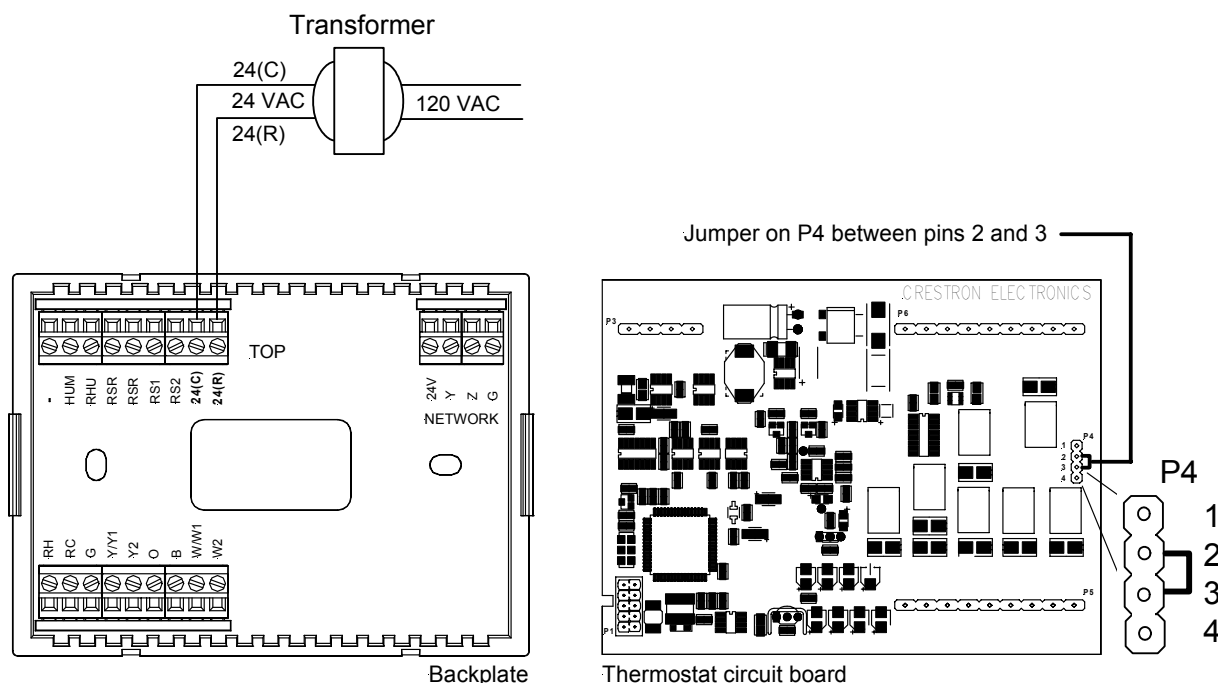

**NOTE:** The P4 jumper position is critical to proper operation and depends on the method used to power the thermostat.

### Three-Wire Heating System Connections

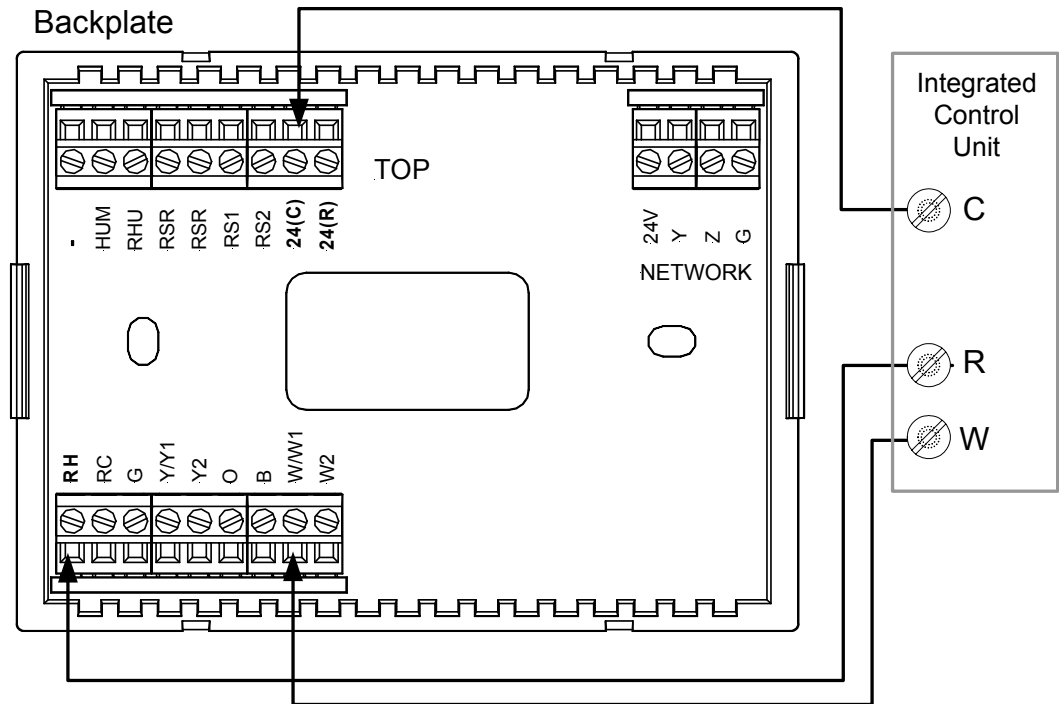

### Thermostat Circuit Board

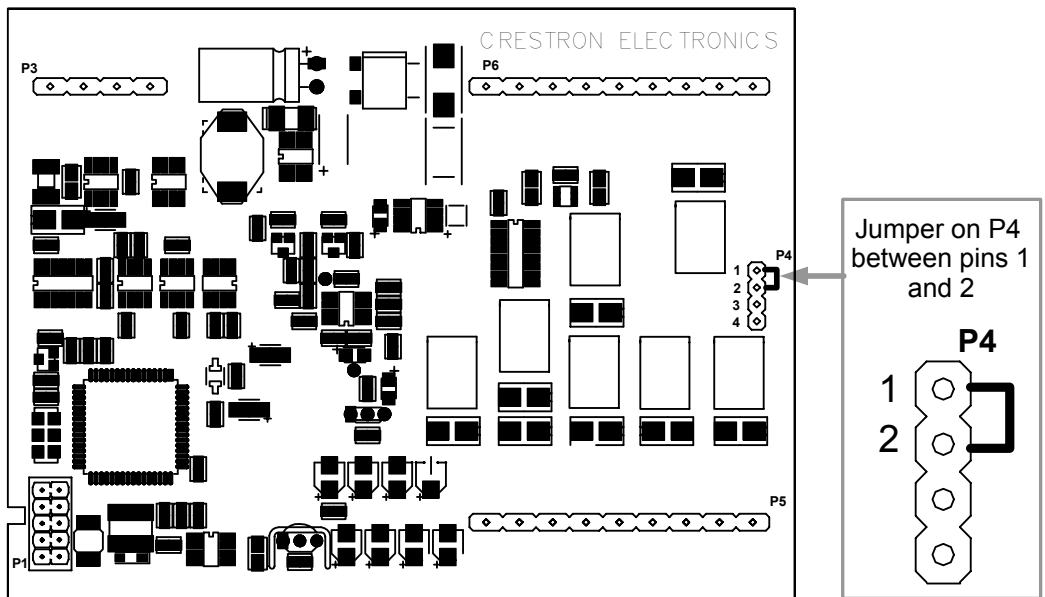

### Five-Wire Heating/Cooling System Connections

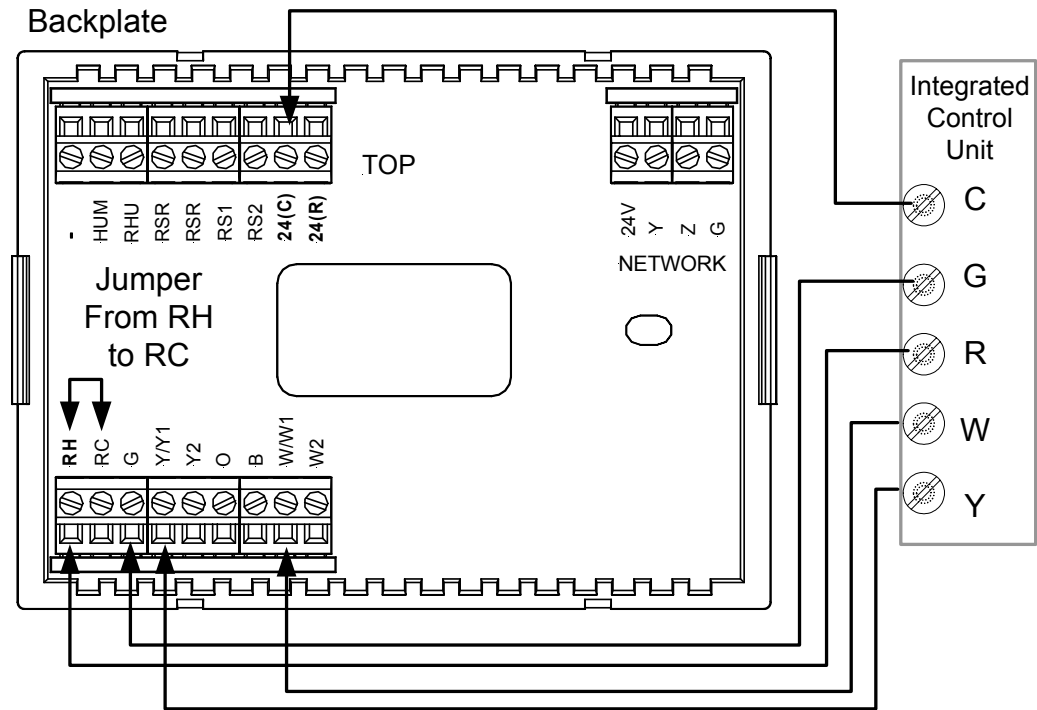

### Thermostat Circuit Board

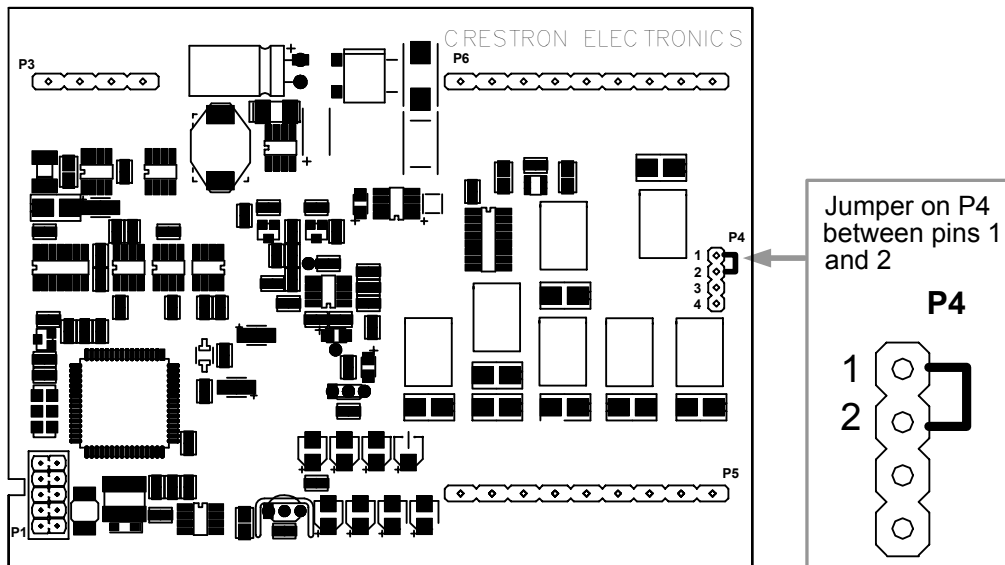

### Heat Pump Connections (Single & Two-Stage)

*Aux Heat connected to W/W1 – RH and RC jumped together*

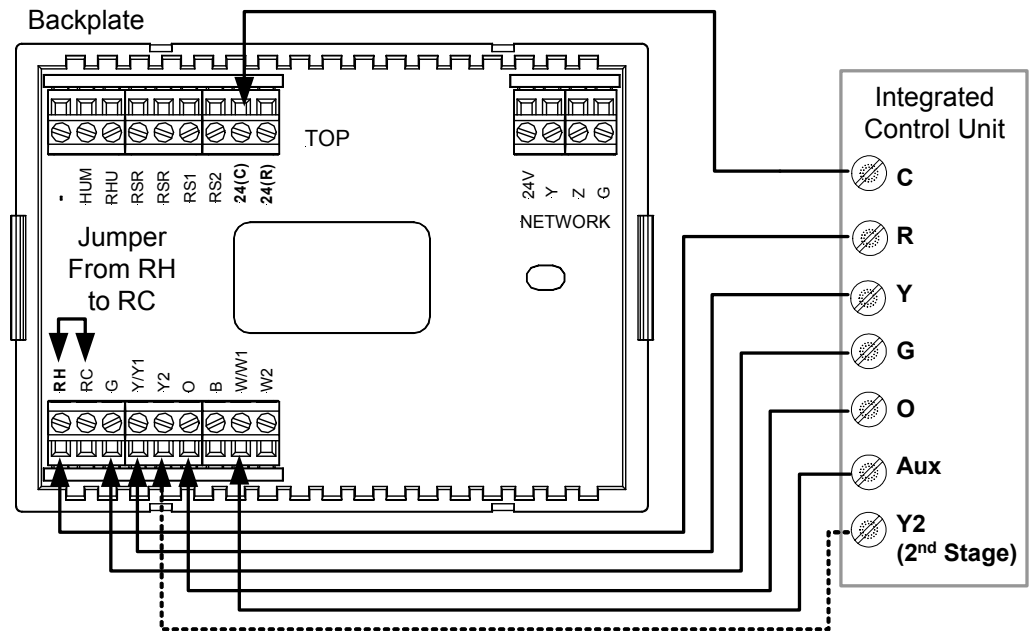

Thermostat Circuit Board

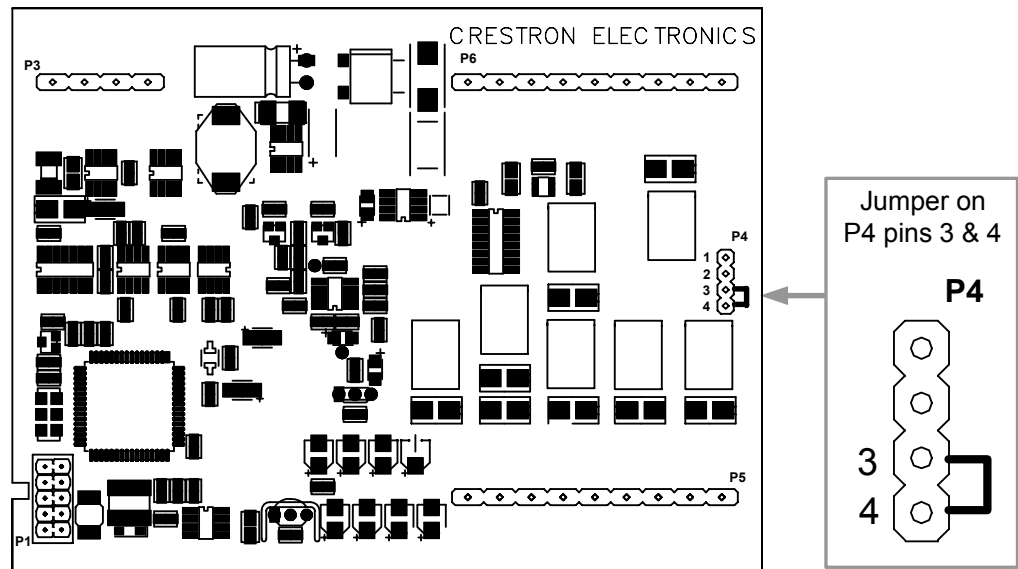

**NOTE:** For wiring details, refer to the general Heat Pump schematic on the following page.



*Generalized Two Stage Heat Pump Schematic*

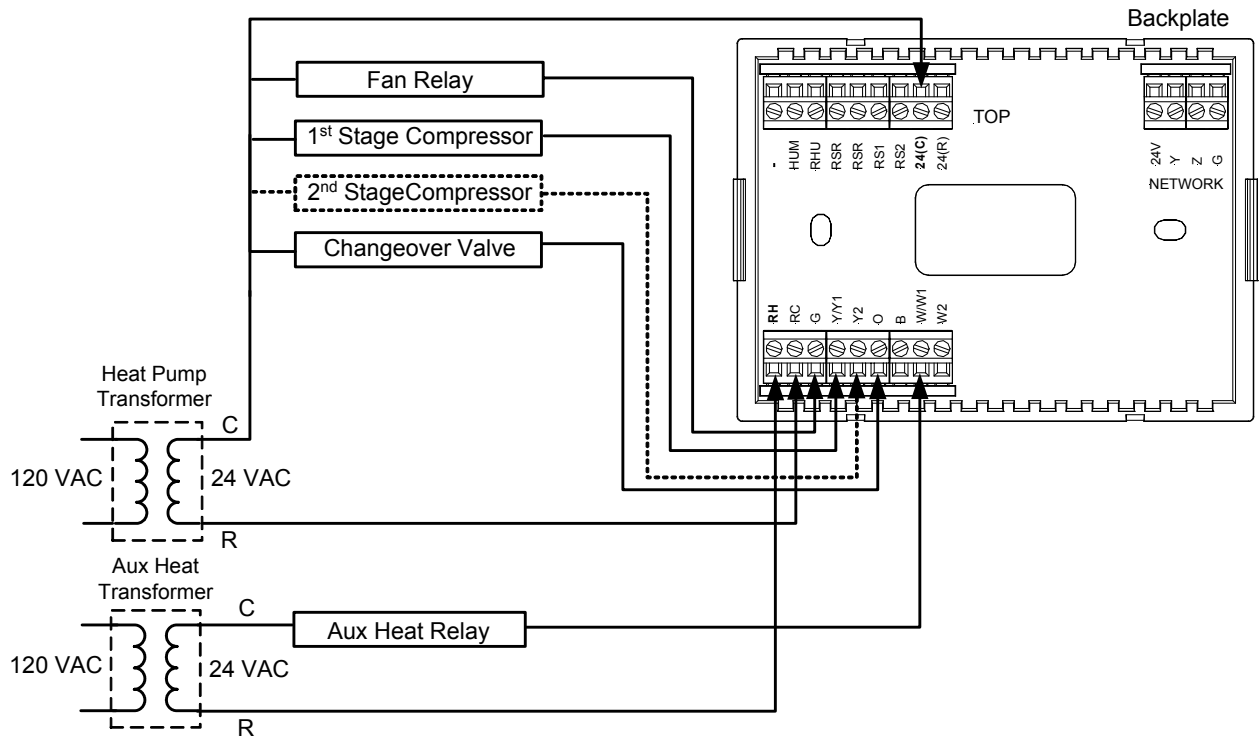

---

## Installation

The location of the thermostat can affect its performance and efficiency. Install the thermostat away from direct sunlight, drafts, doorways, skylights, and windows. Also make sure the thermostat is conveniently located for programming, and do not mount on an exterior wall. The thermostats may be mounted directly to drywall or to a single-gang box.

Thermostats and sensors are mounted 60 inches (152.4 cm) above the finished floor (HVAC industry standard).

Refer to the following illustrations. Do the following to install the CHV-TSTAT or the CHV-THSTAT.

---

**NOTE:** When installing directly on drywall, use anchoring screws and hardware. Make sure the back of the thermostat is flush with drywall and the unit is level.

---

### Required Hardware

- Thermostat
- Phillips screwdriver (not supplied)
- Two 6/32 x 1 inch panhead screws (supplied) for mounting to a single-gang box
- Single-gang box (not supplied)
- Wall anchors (not supplied) and screws (not supplied) for mounting directly to drywall

1. Separate thermostat front plate from back plate (you may need to exert force when removing the faceplate).
2. Turn off the circuit breaker when connecting power to the thermostat, and connect wiring as required (wiring goes through center hole on back plate).

---

**NOTE:** Ensure the correct position of the P4 jumper; refer to pages 10, 11 and 12.

---

3. Attach back plate to drywall with screws and anchors (anchor hardware not provided) 60 inches above the finished floor. Thermostat may also be mounted to a single-gang box mounted horizontally, using the two 6/32 x 1 in panhead screws provided. If using a five-sided single-gang box, fill with insulation material to minimize wall air ingress. Ensure that the thermostat is level and the ventilation holes in the backplate are not blocked.
4. Note orientation of front plate connection leads and reattach the front plate on the back plate (make sure front plate snaps in place and no wires are pinched).

---

**NOTE:** If replacing an existing thermostat, make note of the wire colors and positions before removing the old thermostat.

---

*Installation View – Single gang electrical box – horizontal mounting*

**NOTE:** Install insulation in the gang box to prevent inaccurate readings.

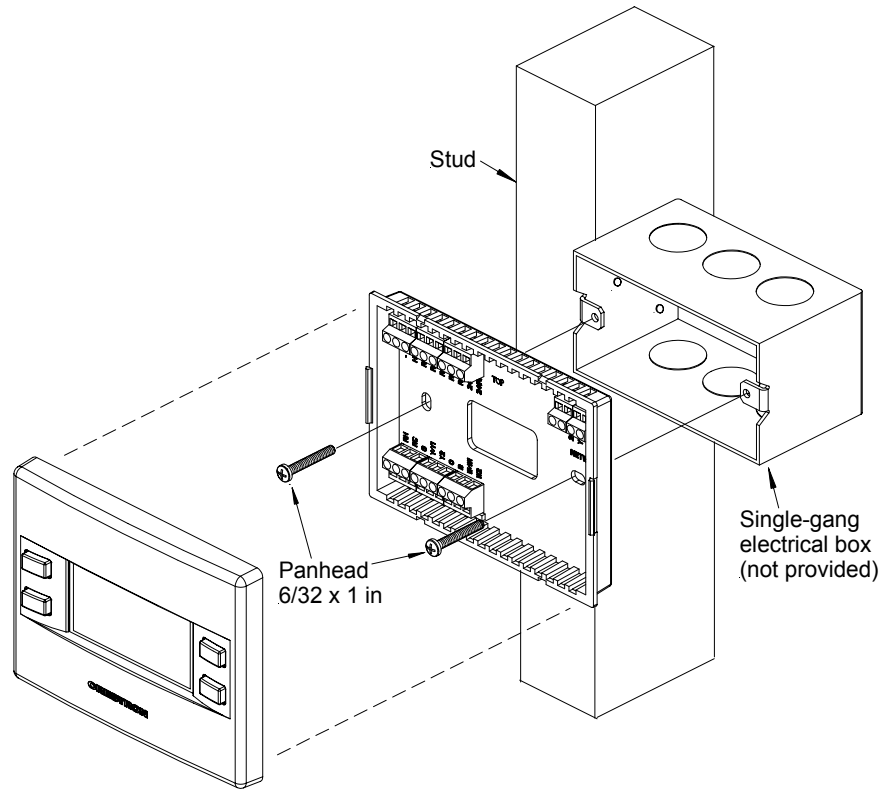

*Installation view – Direct mount to wall*

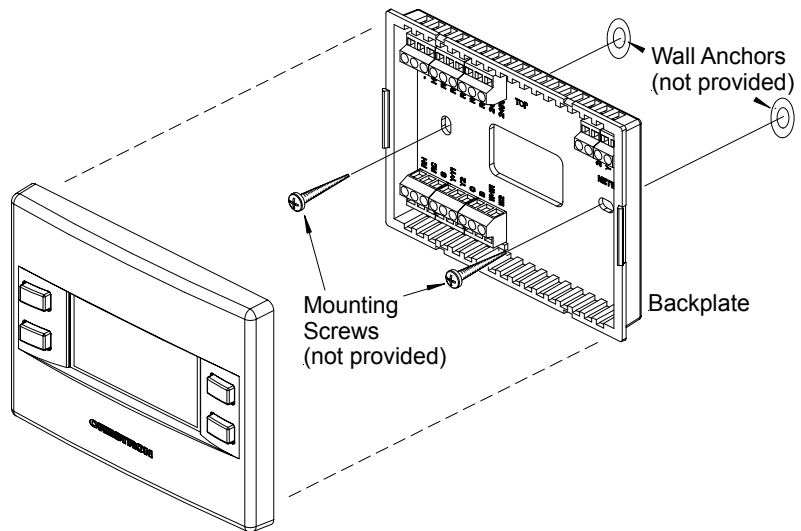

# Thermostat Setup and Operation

## Setup Procedure

After the thermostat is installed, it is necessary to set it up. Follow these directions. Press and hold the **MODE** and **VIEW** buttons simultaneously for five seconds to access the setup menus.

The following SETUP screens appear in this order:

1. SYSTEM
2. SYSTEM PERFORMANCE
3. HUMIDITY/FAN OPTIONS
4. DEVICE OPTIONS
5. SCREEN OPTIONS
6. DISPLAY OPTIONS
7. SENSORS
8. SERVICE/TEST

Use the **MODE** button to advance to the next setup screen.

### 1. System

Press **VIEW** to select the parameter: Heating System Type (Heat/Cool or heat pump), Heat stages (1 or 2), Cool Stages (1 or 2), and radiant or forced air system. A box appears around the selected parameter.

Press the Arrow keys (**▲▼**) to enter the value of the selected parameter.

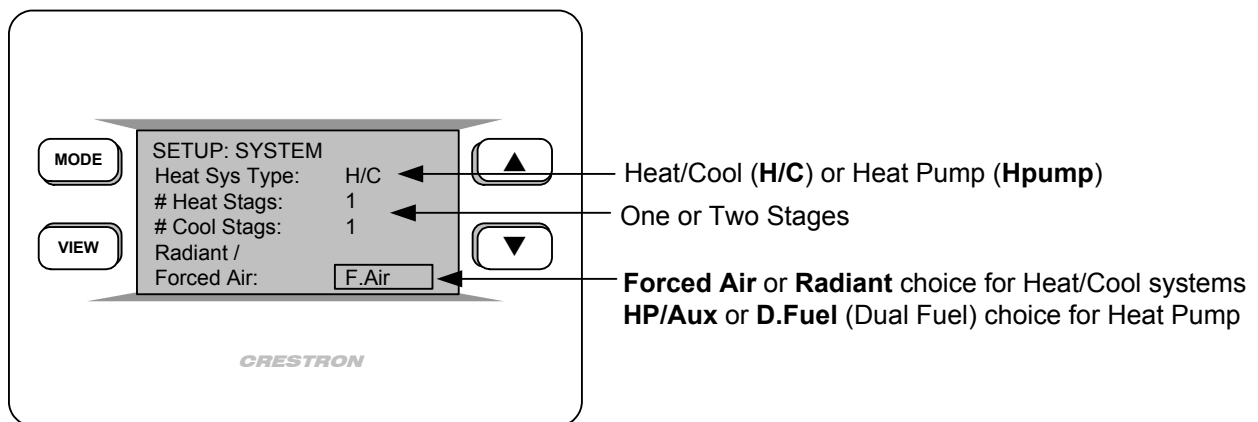

### 2. System Performance

Press the **MODE** button to access the next menu, *SYSTEM PERFORMANCE*. Press **VIEW** to select preferences. Press the Arrow keys (**▲▼**) to select the value of the parameter.

**Anticipators**  
 (valid selections are 1 through 6)  
 Low number = more frequent cycles and faster response (tighter regulation)  
 High number = less frequent cycles and slower response (looser regulation)

**Auto Mode Dead Band**  
 (valid selections are 2 through 6°)  
 The minimum differential between heating and cooling setpoints (Dual Setpoint Auto set to **Yes** in Display Options on page 19).

**HP Balance Point** (Heat Pump Systems only)  
 Minimum outdoor temperature at which the heat pump will run (requires outdoor sensor)

**AUX Balance Point** (Heat Pump with Aux only)  
 Maximum outdoor temperature at which Aux Heat System supplements the heat pump (requires outdoor sensor)

---

**NOTE:** Setting the HP Balance Point to 0° can disable Heat pump. Setting the Aux Balance Point to 90° can disable Aux Heat.

---

### 3. Humidifier/Fan Options

Press the **MODE** button to access the *HUMIDIFIER/FAN OPTIONS*. Press **VIEW** to select option. Press the Arrow keys (**▲▼**) to select the value of the parameter.

**Display Humidity Pages?**  
 Yes or No

**Cold Weather Compensation?**  
 Yes or No. Modifies the humidifier output to prevent condensation on the windows. Requires an outdoor temperature sensor.

**Run Fan in Heat Calls?**  
 Yes or No  
 Most heating systems run the fan automatically. If your heating system requires fan control, select Yes.

### 4. Device Options

Press the **MODE** button to access the *DEVICE OPTIONS*. Press **VIEW** to select options. Press the Arrow keys (**▲ ▼**) to select the value of the parameter.

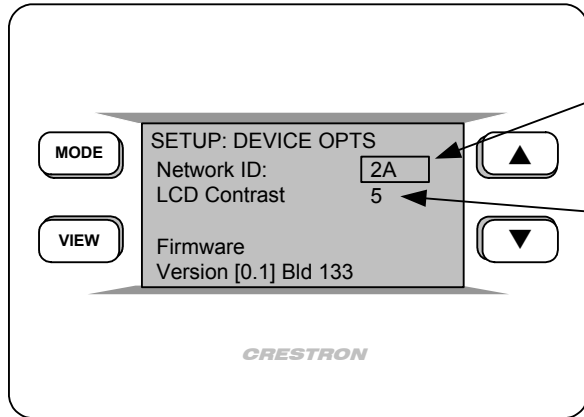

**Select Network ID**

Valid entries are 03 to FE in Hex to match the network ID set for the thermostat in SIMPL Windows

**Select LCD Screen Contrast**

(1 Lighter through 10 Darker)

### 5. Screen Options

Press the **MODE** button to access the *SCREEN OPTIONS*. Press **VIEW** to select each option. Press the Arrow keys (**▲ ▼**) to select the value of the parameter.

---

**NOTE:** The pages in the following setup screen refer to the screens that are seen by the user when the **VIEW** key is pressed in the normal operating mode.

**Outdoor Page** – Temperature/humidity of the outside sensor (if the optional sensor is installed). May also be imported from Cresnet.

**Global Page** – Temperature/humidity selection and system status for entire house. Allows setting of temperature/humidity throughout a multi-thermostat system from a single location. Must be wired and programmed as part of a Cresnet system.

**Remote Function Page(s)** – When part of a Cresnet system, remote function pages allows control of other functions (for example: lights, alarms, etc.). Each of the two pages has two definable buttons. The up **▲** and down **▼** keys are set by indirect text for each page, refer to “CHV-TSTAT and CHV-THSTAT Advanced Symbol” on page 26.

---

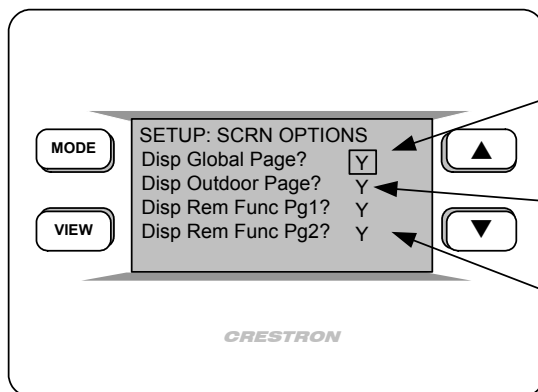

**Display Global Page?**

Yes or No

**Display Outdoor Page?**

Yes or No

**Display Remote Function Pages?**

Yes or No

## 6. Display Options

Press the **MODE** button to access the *DISPLAY OPTIONS*. Press **VIEW** to select options. Press the Arrow keys (**▲▼**) to select the value of the parameter.

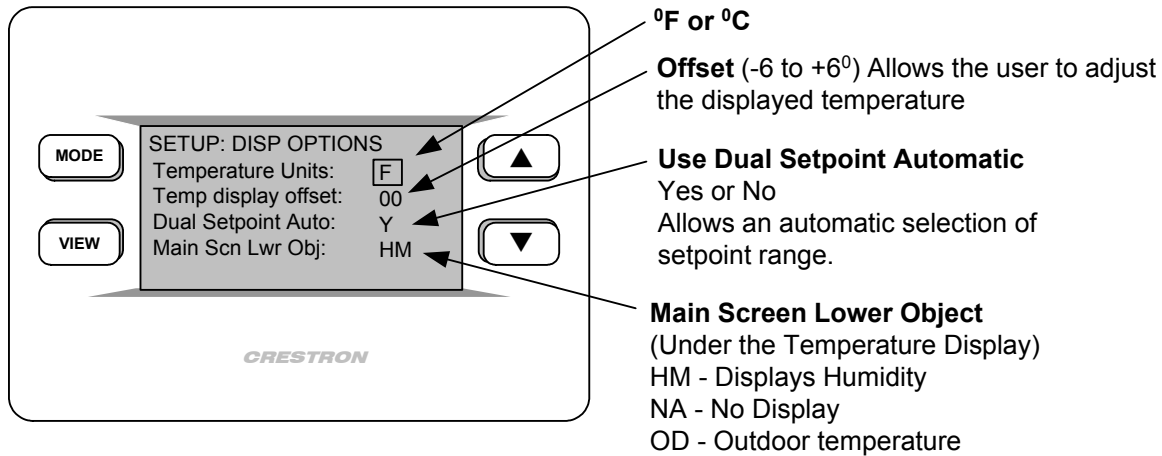

---

**NOTE:** Dual Setpoint Automatic – Selecting Yes allows the user to explicitly set the heat and cool setpoints in auto mode. Selecting No shows one setpoint and the thermostat automatically selects the operating systems to maintain that setpoint temperature.

**NOTE:** The Offset option permits recalibration of the room temperature sensor. There are various reasons why users may want to adjust the temperature. The selection number is the number of degrees added or subtracted to the actual temperature. The range is -6° to +6°. Factory default is 0°. This adjustment changes the actual regulated temperature, not just the display.

---

## 7. Sensors

Press the **MODE** button to access the *SENSORS*. Press **VIEW** to select each sensor type. Press the Arrow keys (**▲▼**) to select the value of the parameter.

---

**NOTE:** The sensors are used for Temperature/Humidity Averaging. Choose USE to include each sensor, or OMIT to exclude each sensor in the averaging equation. Choose OMIT if the remote sensors are not installed.

**NOTE:** The thermostat will not leave the setup mode unless a valid sensor selection is made. An omitted remote humidity sensor for a CHV-TSAT does not prevent setup exit.

---

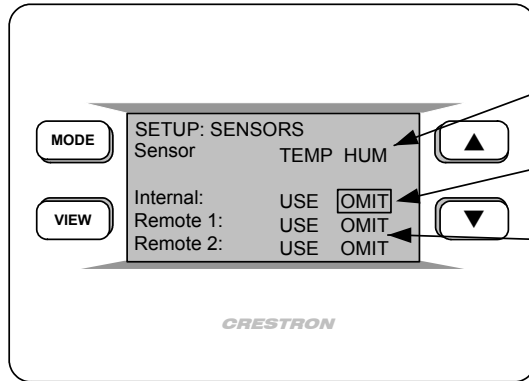

**Select Sensor Type**  
Temperature and/or Humidity

**Internal Sensor**  
Temperature/Humidity in CHV-THSTAT  
Temperature only in CHV-TSTAT

**Remote Sensors**  
CHV-RTS temperature only sensor  
CHV-RTHS temperature/humidity sensor  
Sensors may be indoor or outdoor.  
Choose USE, OMIT, or Outdoor (OD)

**NOTE:** Remote 1 and Remote 2 Options do not appear on this screen if these sensors are not connected.

**NOTE:** Declared outdoor temperature/humidity sensors should have both TEMP and HUM declared as OD (Outdoor).

### 8. SERVICE/TEST

Press the **MODE** button to access the *SERVICE/TEST* setup screen. Press **VIEW** to select each parameter. Press the Arrow keys (**▲ ▼**) to select the value of the parameter.

- H1 – Single Stage Heating
- H2 – Two Stage Heating
- C1 – Single Stage Cooling
- C2 – Two Stage Cooling.

**NOTE:** This screen bypasses all system delays and is used by the installer to manually operate the HVAC system. Only one system can be run at a time.

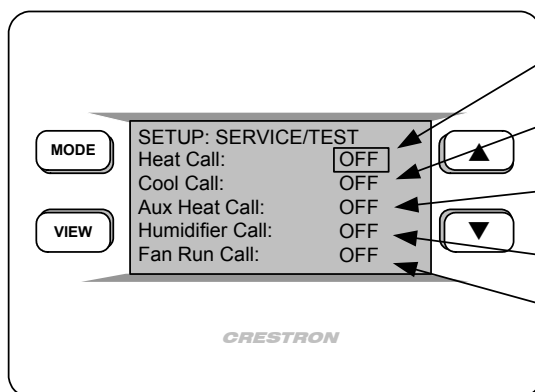

**Heat Call**  
Choose Off, H1, or H2

**Cool Call**  
Choose Off, C1 or C2

**Aux Heat (ON or Off)**  
Only appears on heat pump systems

**Humidifier Call (On or Off) CHV-THSTAT only**

**Fan Run Call (ON or OFF)**

Press **MODE** button to return to the first screen. Simultaneously press and hold the **MODE** and **VIEW** buttons to return to normal operation mode.



## Operating the Thermostat

After setup, configure the thermostat using the following screens.

### Main Screen

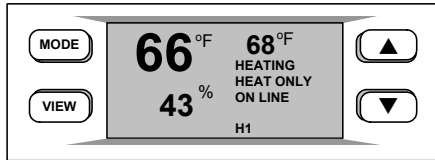

The Main Screen displays the Current Temperature, System Mode, Fan Mode, and Set Point temperatures. The CHV-THSTAT also displays Relative Humidity and Humidifier Mode. Press the **up ▲** arrow button to increase the set point temperature. Press the **down ▼** arrow button to decrease the set point temperature.

**NOTE:** If you selected **Yes** in setup screen #6 for “Dual Setpoint Auto”, pressing **MODE** toggles between the **Heat** and **Cool** setpoints.

This screen also indicates the system currently running:

- H1 – Heat System or Stage 1 Heat System
- H2 – Stage 2 Heat System
- AX – Auxiliary Heating System
- C1 – Cooling System or Stage 1 Cooling System
- C2 – Stage 2 Cooling System



### MODE Button

It may also be necessary to access the following series of screens. Pressing the **MODE** button allows the user to access the following screens:

1. System Mode
2. Fan Mode
3. Humidifier
4. Crestron System
5. Global Update

### System Mode Screen

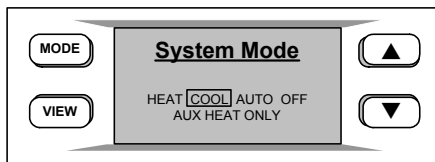

### 1. SYSTEM MODE

The “System Mode” screen appears when the **MODE** button is initially pressed. Use the **up ▲** and **down ▼** arrow buttons to select HEAT, COOL, AUTO, OFF or AUX Heat Only.

**NOTE:** The **AUTO** selection allows the system to switch between Heat and Cool automatically as needed to maintain the temperature.

**NOTE:** The **AUX HEAT ONLY** is for the backup heating system on Heat Pump systems only. Allows the backup system to operate without operating the heat pump.

### Fan Mode Screen

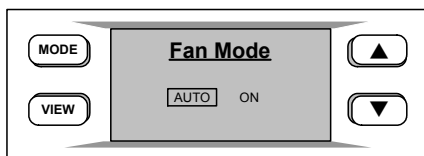

### 2. FAN MODE

Pressing the **MODE** button again displays the “Fan Mode” screen.

Use the **up ▲** and **down ▼** arrow buttons to select AUTO or ON.

**NOTE:** In **AUTO**, the fan runs only when the system calls for heat or cool. In **ON**, the fan runs continuously.

*Humidifier Screen*

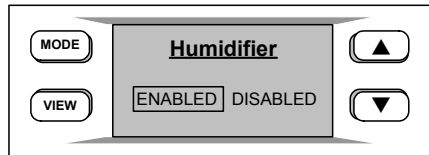

*Crestron System Screen*

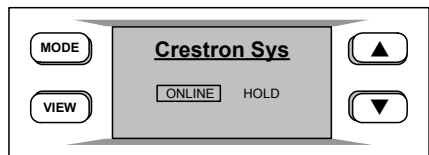

*Global Update Screen*

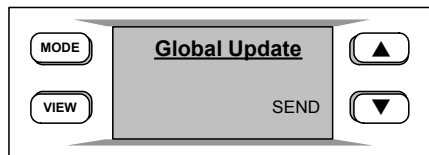

**3. Humidifier (CHV-THSTAT ONLY)**

Pressing the **MODE** button displays the “Humidifier” screen.

Use the **up ▲** and **down ▼** arrow buttons to select ENABLED or DISABLED.

**4. CRESTRON SYSTEM**

Pressing the **MODE** button again displays the Crestron System screen. Use the **up ▲** and **down ▼** arrow buttons to select ONLINE or HOLD.

ONLINE – Data flows both ways, to and from the thermostat, enabling adjustment from a remote location.

HOLD – Data flows one way, from the thermostat, blocking system commands to change the temperature and humidity when you do not want the current settings reset.

**5. GLOBAL UPDATE**

Pressing the **MODE** button again displays the Global Update screen. Allows a single thermostat location to update the current temperature settings to all other thermostats on the system, provided that this function has been defined in the Crestron program.

Press the **down ▼** button to send the update.

Pressing the **MODE** button again returns you to the Main Screen

**VIEW Button**

The following screens are accessed by pressing the **VIEW** button:

1. Humidity (If enabled in Setup)
2. Outdoor (If enabled in Setup)
3. Messages

---

**NOTE:** If enabled, the **VIEW** button also allows access to the remote button function screens. When part of a Cresnet system, the up ▲ and down ▼ arrow buttons can be used to enable other functions (i.e., lighting control, alarm system, etc.).

---

*Humidity Screen*

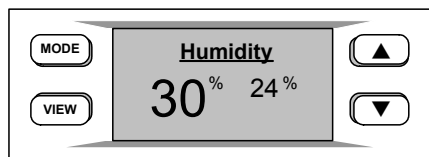

**1. HUMIDITY**

Press the **VIEW** button to display the “Humidity” screen.

Use the **up ▲** and **down ▼** arrow buttons to adjust the Humidity Set Point level (CHV-THSTAT only). This page only appears if enabled in the setup. Refer to “HUMIDIFIER/FAN OPTIONS” on page 17.

---

**NOTE:** If a CHV-RTHS temperature/humidity sensor is installed, a CHV-TSTAT can import and display the humidity.

---

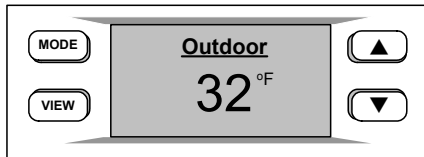
*Outdoor Screen*2. OUTDOOR

Press the **VIEW** button again to display the “Outdoor” screen. This allows the user to view the outdoor temperature (if an outdoor sensor has been installed) and outdoor humidity (if available). Outdoor temperature/humidity can come from an outdoor sensor wired directly to the thermostat or through the Cresnet system from another source. This page is only displayed if enabled in the setup. Refer to “SCREEN OPTIONS” on page 18.

---

**NOTE:** This is only a display and not for system activation. This display can be shown on either the CHV-TSTAT or the CHV-THSTAT.

---

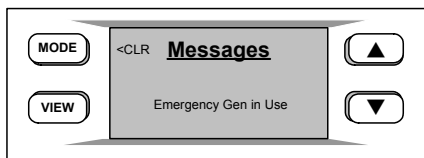
*Messages Screen*3. MESSAGES

Press the **VIEW** button again to display the “Messages” screen. This screen allows the user to view any text messages sent from the control system (Only when part of a Cresnet system). Text messages are limited to 4 lines, approximately 20 characters per line (including spaces). Allow for word wrap by staying within the 20 characters/spaces per line maximum. The thermostat auto-hyphenates when nearing the end of a line. You may use carriage returns to force a line change.

Press the **MODE** button to clear (CLR) the message(s). Acknowledges to the control system that the message has been read.

---

## Programming Software

*Have a comment about Crestron software?*

*Direct software related suggestions and/or complaints to Crestron via email (software@crestron.com). Do not forward any queries to this address. Instead refer to "Further Inquiries" on page 38.*

The CHV-TSTAT and CHV-THSTAT thermostats do not require programming when used as stand alone devices. Programming as part of a Cresnet system allows additional functionality, including:

**Global Update and Global Page display** – Allows viewing and setting the temperature/humidity for an entire house in a multi-thermostat system.

**Remote Function pages** – Allows system control of other functions (lighting, alarms, etc.). Two pages, two functions per page.

**System Messaging** – Allows the control system to send text messages to the thermostat.

Setup is easy thanks to Crestron's Windows®-based programming software. The Crestron D3 Pro Software creates a complete project, with no special programming required. D3 Pro completes all necessary programming for a base system including the control system program. Once D3 Pro creates the project, the system interfaces and program logic can be customized. It can also be modified with Crestron development tools (i.e., SIMPL Windows®) software, although this should rarely be necessary.

The program output of D3 Pro is a SIMPL Windows program with much of the functionality encapsulated in macros. Therefore, extending the capabilities of the system is very easy. Crestron D3 Pro and SIMPL Windows are intended for users with different levels of programming knowledge. The flexibility of each is proportional to the degree of programming expertise (i.e., the more flexible, the more a programmer needs to know and account for). Of course, one can begin programming using the easiest method (Crestron D3 Pro) and use advanced techniques that are available from SIMPL Windows to customize the job.

D3 Pro comes with templates for all supported interfaces. If a user wishes to create a touchpanel project using templates with a different look-and-feel this can be accomplished by making a custom template. This custom template can then be used by D3 Pro to create the final project files. The following are recommended software version requirements for the PC:

- [Optional] D3 Pro version 1.1 or later (scheduled for May 2003). Requires SIMPL Windows.
- SIMPL Windows version 2.03.18 or later. Using D3 Pro will require SIMPL Windows 2.04 or later.
- Requires SIMPL+ Cross Compiler version 1.1.
- Crestron Database version 15.9.3 or later if using D3 Pro. If only using SIMPL Windows, Crestron Database 15.8.8 is required.

*The easiest method of programming, but does not offer as much flexibility as SIMPL Windows.*

## Programming with Crestron D3 Pro

Crestron D3 Pro offers automatic programming for residential and commercial systems. The interface of this tool guides you through a few basic steps for designating rooms and specifying the control system, devices, and functionality. Crestron D3 Pro then programs the system, including all control system logic.

Crestron D3 Pro is fully integrated with the Crestron suite of software development tools and accesses these tools behind the scenes, enabling you to easily create robust systems.

## Programming with SIMPL Windows

**NOTE:** The following assumes that the reader has knowledge of SIMPL Windows. If not, refer to the extensive help information provided with the software.

**NOTE:** In the following description, the PRO2 control system is used.

SIMPL Windows is Crestron's software for programming Crestron control systems. It provides a well-designed graphical environment with a number of workspaces (i.e., windows) in which a programmer can select, configure, program, test, and monitor a Crestron control system. SIMPL Windows offers drag and drop functionality in a familiar Windows® environment.

This section describes a sample SIMPL Windows program that includes a CHV-TSTAT.

Configuration Manager is where programmers “build” a Crestron control system by selecting hardware from the *Device Library*. In Configuration Manager, drag the PRO2 from the Control Systems folder of the *Device Library* and drop it in the upper pane of the *System Views*. The PRO2 with its associated communication ports is displayed in the *System Views* upper pane.

### PRO2 System View

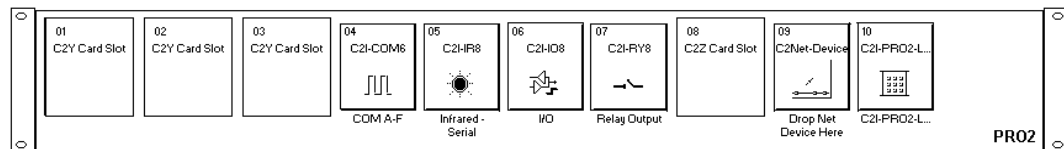

The *System Views* lower pane displays the PRO2 system tree. This tree can be expanded to display and configure the communications ports.

### Expanded PRO2 System Tree

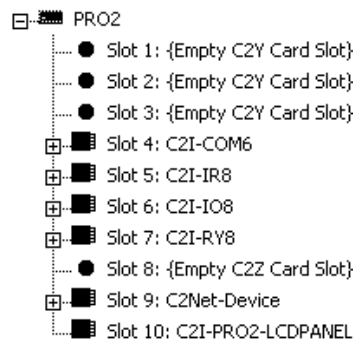

### ***C2Net-Device Slot in Configuration Manager***

To incorporate a CHV-THSTAT or CHV-TSTAT into the system, drag one of the symbols for the thermostat from the Crestron Sensing Modules folder of the *Device Library* and drop it on C2-NET Device slot in *System Views*. The PRO2 system tree displays the thermostat symbol in Slot 9, with a default NET ID of 2A as shown in the example graphic below.

#### ***C2Net Device, Slot 9***

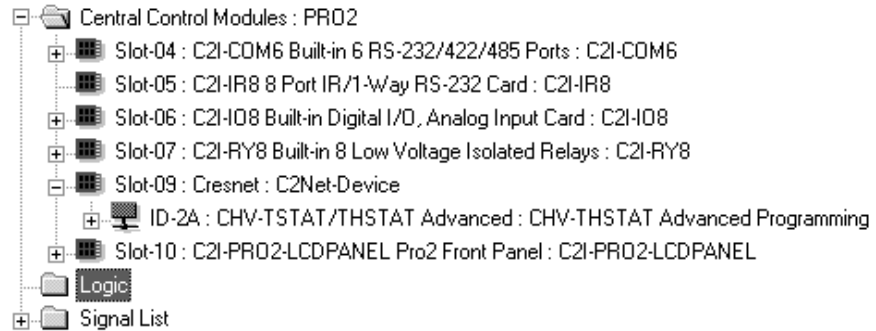

### ***Setting the Net ID in Device Settings***

Double-click the thermostat icon in the upper pane to open the “Device Settings” window. This window displays the device information. Select the *Net ID* tab to change the Net ID, as shown in the following graphic.

#### ***“Device Settings” Window for the CHV-THSTAT***

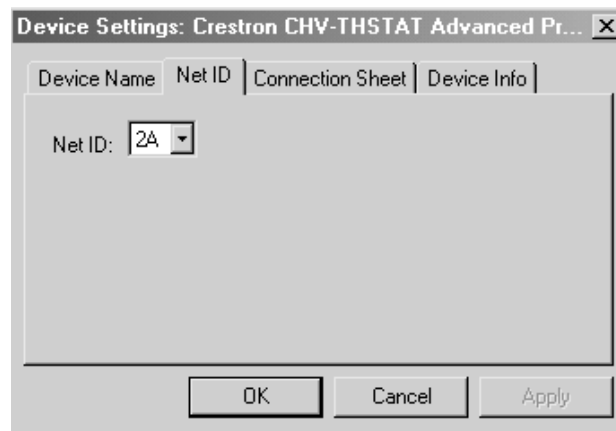

### ***Basic and Advanced Symbols in Programming Manager***

Programming Manager is where programmers “program” a Crestron control system by assigning signals to symbols.

You may choose between two different symbol sets for the thermostats, advanced and basic. The advanced symbol allows a broader range of functions, including the ability to control other devices (lighting, alarms, etc.), interact with other thermostats, receive messages from the Crestron system, import and export temperature and humidity information. The basic symbol, while simpler, still provides all the necessary connections to operate and control a Heating Ventilation and Air Conditioning (HVAC) system.

**CHV-TSTAT AND CHV-THSTAT BASIC SYMBOL**

The following diagram shows the basic thermostat symbols in the SIMPL Windows' Programming Manager. Refer to page 31 for a detailed description of the inputs and outputs

*Detail View of the Basic CHV-THSTAT and CHV-TSTAT Symbol  
Digital Inputs/Outputs*

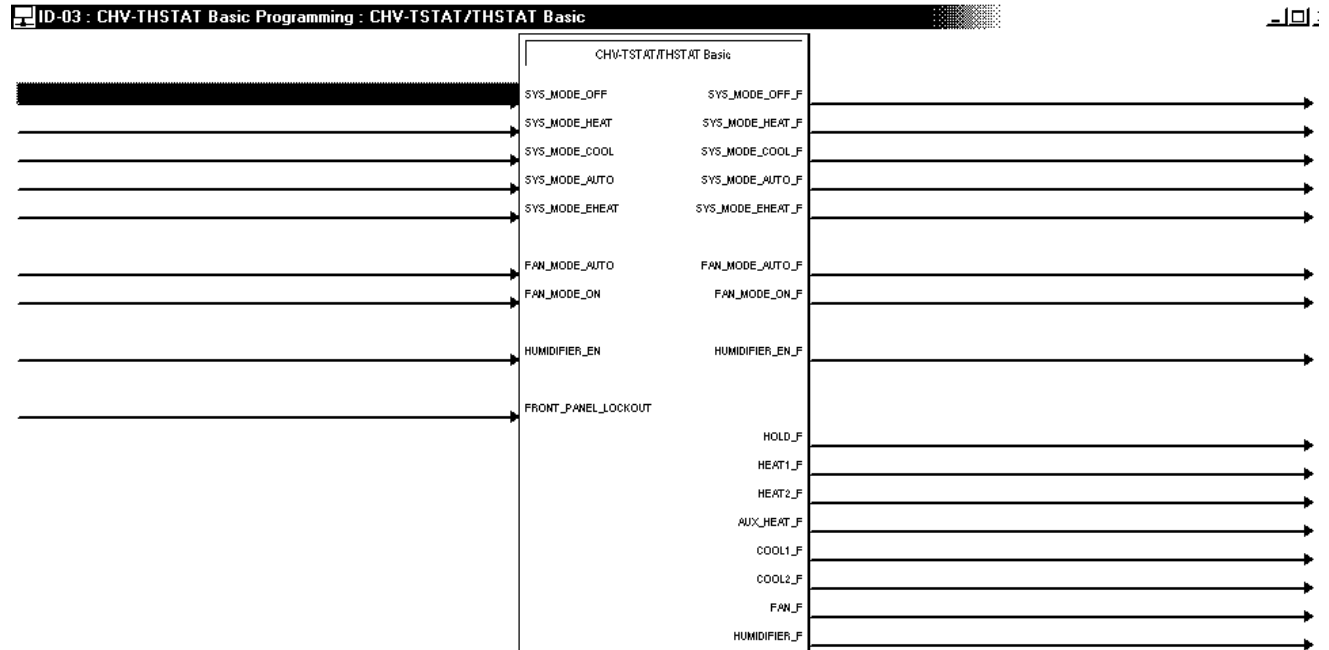

*Detail View of the Basic CHV-THSTAT and CHV-TSTAT Symbol  
Analog Inputs/Outputs*

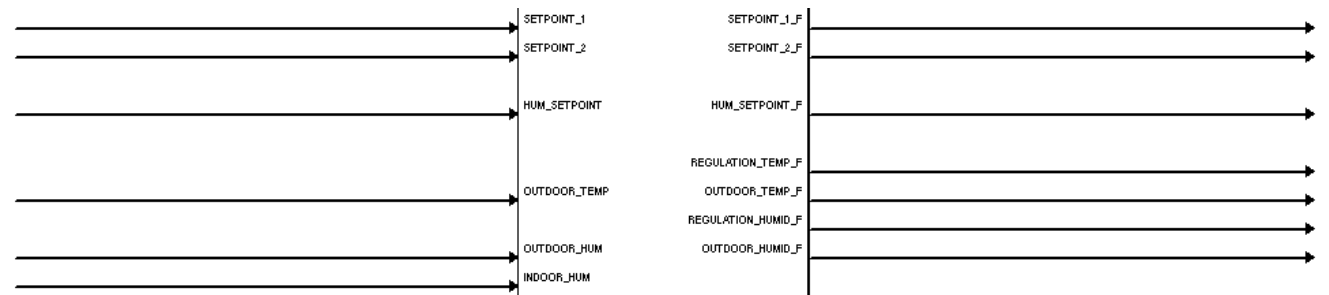

**CHV-THSTAT AND CHV-TSTAT ADVANCED SYMBOL**

The advanced symbol allows additional functionality, including: Global Update and Global Page display, Function pages, and System Messaging. Refer to page 31 for a detailed description of the inputs and outputs.

*Detail View of the Advanced CHV-THSTAT and CHV-TSTAT Symbol  
Digital Inputs/Outputs*

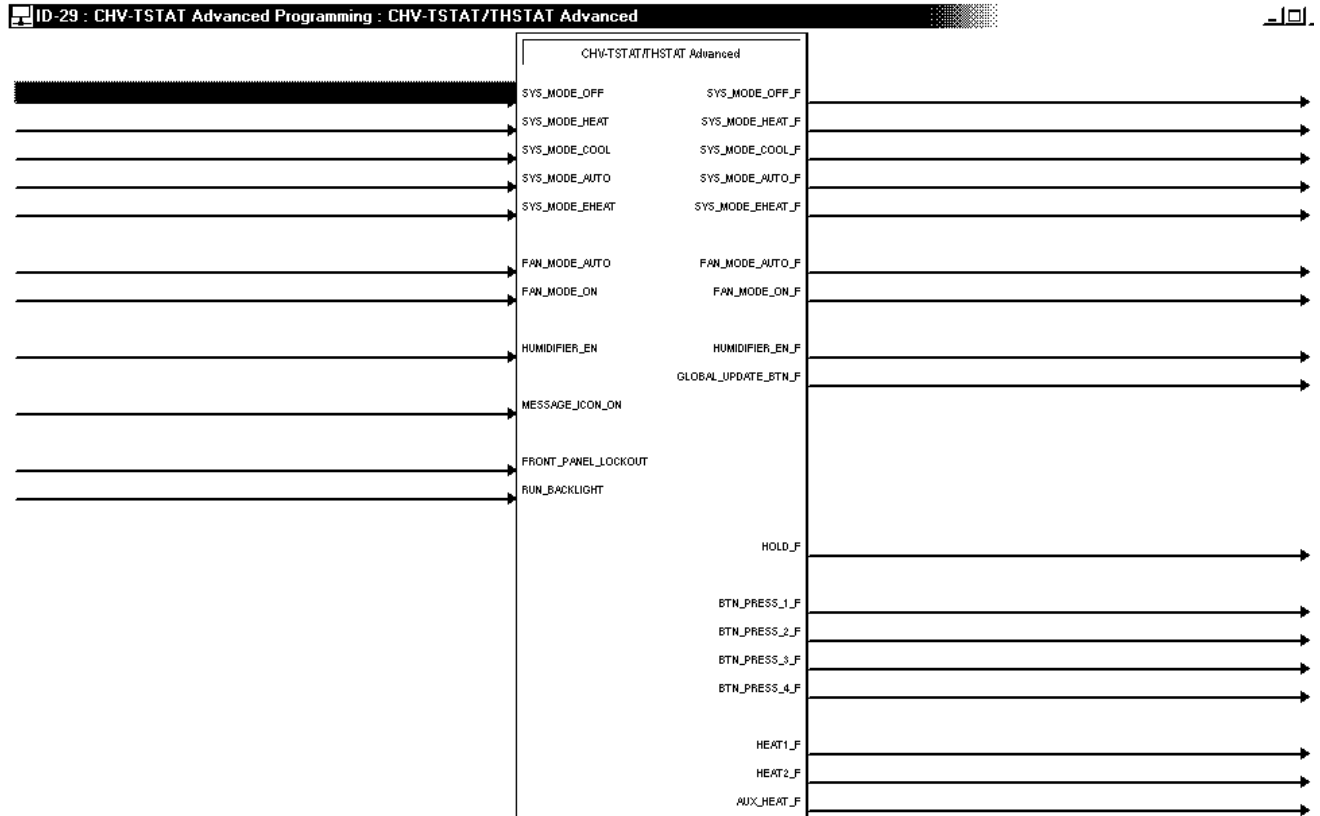



*Detail View of the Advanced CHV-THSTAT and CHV-TSTAT Symbol  
Digital Outputs*

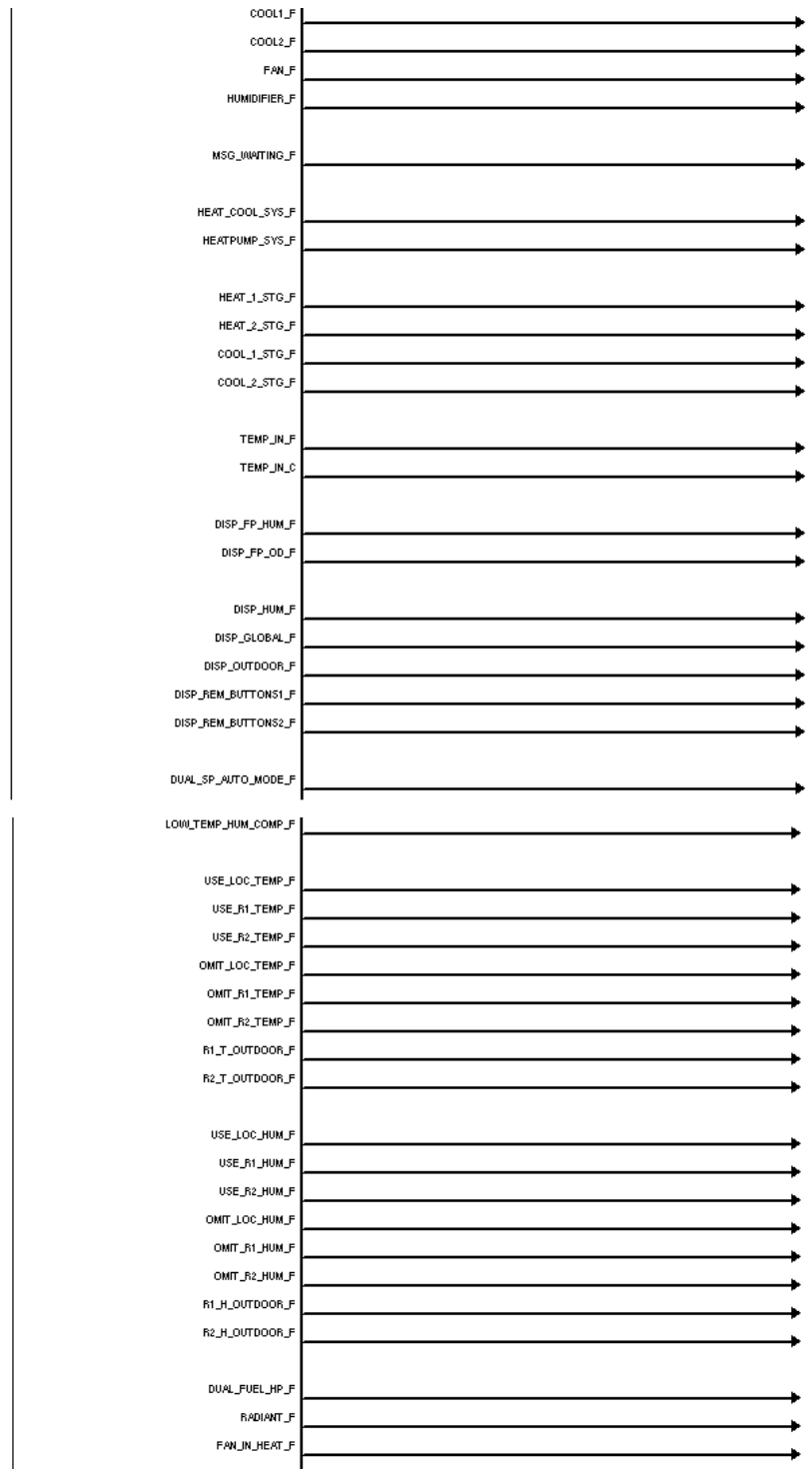

*Detail View of the Advanced CHV-THSTAT and CHV-TSTAT Symbol  
Analog Inputs/Outputs*

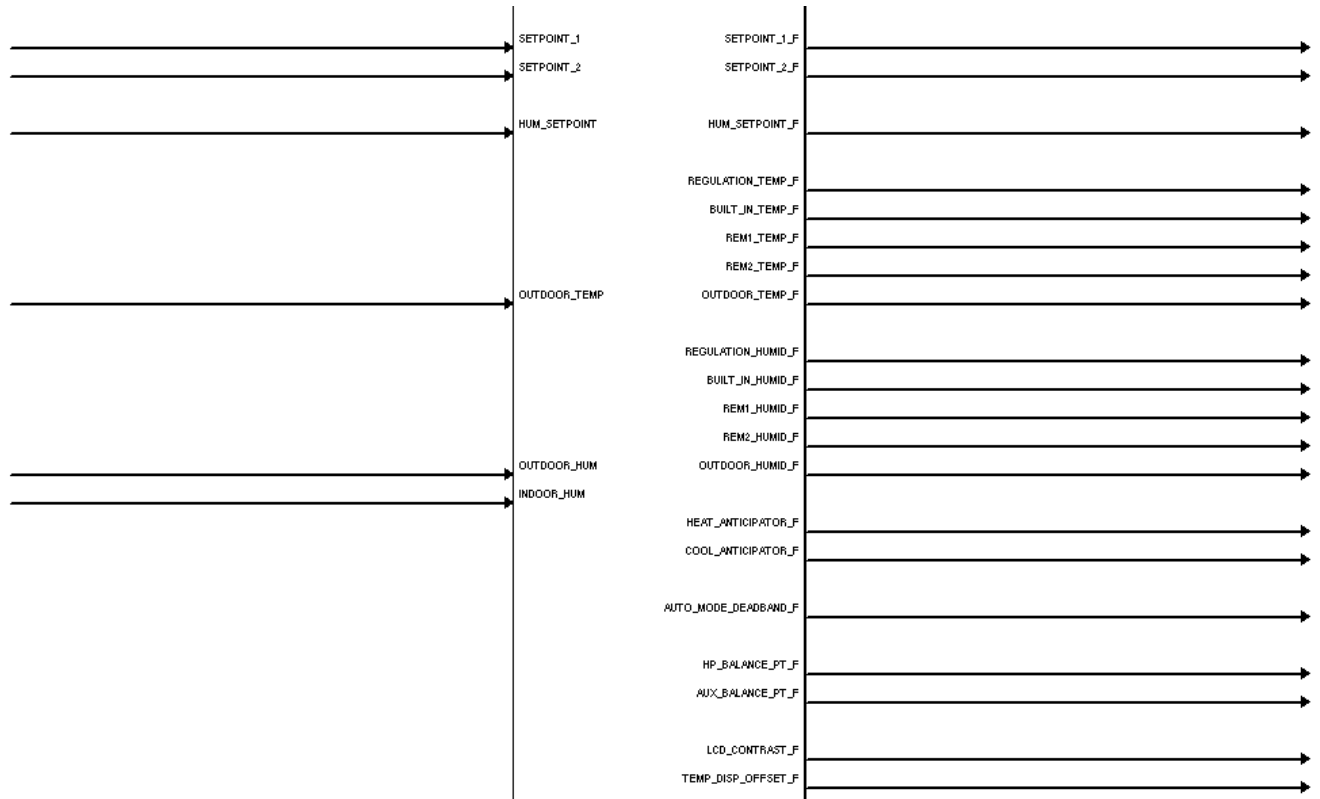

*Detail View of the Advanced CHV-THSTAT and CHV-TSTAT Symbol  
Serial Inputs*

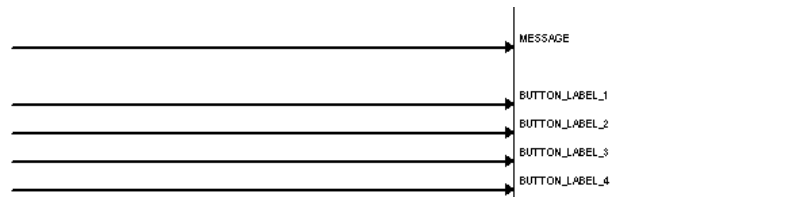

### Thermostat Symbol Definitions

The following tables contain a detailed description of the inputs and outputs for the basic and advanced CHV-TSTAT and CHV-THSTAT symbols.

**NOTE:** For the simplest possible programming, connect an appropriate analog signal to SETPOINT\_1, and possibly SETPOINT\_2.

#### System Mode Related Digital Joins

| Signal Name      | Symbol* | I/O    | Definition                                                                                                                         |
|------------------|---------|--------|------------------------------------------------------------------------------------------------------------------------------------|
| SYS_MODE_OFF     | Both    | Input  | Forces off mode (no HVAC system operation)                                                                                         |
| SYS_MODE_HEAT    | Both    | Input  | Forces heat only mode when asserted                                                                                                |
| SYS_MODE_COOL    | Both    | Input  | Forces cool only mode when asserted                                                                                                |
| SYS_MODE_AUTO    | Both    | Input  | Forces auto mode when asserted                                                                                                     |
| SYS_MODE_EHEAT   | Both    | Input  | Forces emergency heat only mode on heat pump systems<br>Has no effect if sent to a heat/cool (H/C) system                          |
| SYS_MODE_OFF_F   | Both    | Output | Outputs for the joins above                                                                                                        |
| SYS_MODE_HEAT_F  |         |        | Can be used as feedback to show actual system mode status since the mode can be changed from the thermostat end or through Cresnet |
| SYS_MODE_COOL_F  |         |        |                                                                                                                                    |
| SYS_MODE_AUTO_F  |         |        |                                                                                                                                    |
| SYS_MODE_EHEAT_F |         |        |                                                                                                                                    |

\*Joins are either available in **both** basic and advanced symbols or in the **advanced** symbol only.

#### Fan Mode Related Digital Joins

| Signal Name     | Symbol | I/O    | Definition                                |
|-----------------|--------|--------|-------------------------------------------|
| FAN_MODE_AUTO   | Both   | Input  | Forces auto fan mode when asserted        |
| FAN_MODE_ON     | Both   | Input  | Forces fan ON mode, fan runs continuously |
| FAN_MODE_AUTO_F | Both   | Output | Feedback for the auto fan mode join above |
| FAN_MODE_ON_F   | Both   | Output | Feedback for the on fan mode join above   |

#### System Operation Feedback Digital Joins

| Signal Name  | Symbol | I/O    | Definition                                                                                            |
|--------------|--------|--------|-------------------------------------------------------------------------------------------------------|
| HEAT1_F      | Both   | Output | Asserted for the duration that heat stage 1 is running                                                |
| HEAT2_F      | Both   | Output | Asserted for the duration that heat stage 2 is running                                                |
| AUX_HEAT_F   | Both   | Output | Asserted for the duration that auxiliary heat is running (Heat pump only)                             |
| COOL1_F      | Both   | Output | Asserted for the duration that cooling stage 1 is running                                             |
| COOL2_F      | Both   | Output | Asserted for the duration that cooling stage 2 is running                                             |
| FAN_F        | Both   | Output | Asserted for the duration that the fan is on for any reason                                           |
| HUMIDIFIER_F | Both   | Output | Asserted for the duration that the humidifier is running                                              |
| HOLD_F       | Both   | Output | Indicates that the thermostat has been set "offline" by the user<br>active = offline, inactive=online |

*Other Digital Joins*

| Signal Name         | Symbol   | I/O    | Definition                                                                                                                                                          |
|---------------------|----------|--------|---------------------------------------------------------------------------------------------------------------------------------------------------------------------|
| GLOBAL_UPDATE_BTN   | Advanced | Output | Output that is asserted when the global update "send" button is pressed                                                                                             |
| MESSAGE_ICON_ON     | Advanced | Input  | Causes the front panel third text line to flash "view msg" alternately with "on line/offline," alerting the user to check a message that was sent to the thermostat |
| FRONT_PANEL_LOCKOUT | Both     | Input  | Causes the buttons on the thermostat to become inoperable when asserted, Useful for locking out changes in operation by users                                       |
| RUN_BACKLIGHT       | Advanced | Input  | Triggers the backlight to turn on for its 8 seconds                                                                                                                 |
| BTN_PRESS_1_F       | Advanced | Output | Asserted for the duration that remote button 1 is pressed (up button, remote page 1)                                                                                |
| BTN_PRESS_2_F       | Advanced | Output | Asserted for the duration that remote button 2 is pressed (down button, remote page 1)                                                                              |
| BTN_PRESS_3_F       | Advanced | Output | Asserted for the duration that remote button 3 is pressed (up button, remote page 2)                                                                                |
| BTN_PRESS_4_F       | Advanced | Output | Asserted for the duration that remote button 4 is pressed (down button, remote page 2)                                                                              |
| MSG_WAITING_F       | Advanced | Output | Asserted when an indirect text message is received on \$message join and latched until the user presses the "CLR" button on the message screen                      |

*Humidifier Related Joins (all analog values are in whole %)*

**NOTE:** All humidity-related analog values are input and output as whole numbers. Example: For 47% humidity, the reading is sent as 47.

| Signal Name     | Symbol | I/O    | Definition                                                                                                                                                                                                                                                                      |
|-----------------|--------|--------|---------------------------------------------------------------------------------------------------------------------------------------------------------------------------------------------------------------------------------------------------------------------------------|
| HUMIDIFIER_EN   | Both   | Input  | Enables the humidistat operations when asserted (Digital)                                                                                                                                                                                                                       |
| HUMIDIFIER_EN_F | Both   | Output | Feedback for above (Digital)                                                                                                                                                                                                                                                    |
| HUM_SETPOINT    | Both   | Input  | Analog join that sets the humidity setpoint, 5-70%, all other values ignored, All values are whole numbers, so sending 38 changes the setpoint to 38%                                                                                                                           |
| HUM_SETPOINT_F  | Both   | Output | Feedback output so that changes in the value can be monitored by the control system                                                                                                                                                                                             |
| OUTDOOR_HUM     | Both   | Input  | Input allowing the outdoor humidity value to be displayed on the "outdoor" page even if the particular unit does not have an outdoor remote sensor                                                                                                                              |
| OUTDOOR_HUM_F   | Both   | Output | Output for outdoor humidity. It is only active when a particular unit has a remote outdoor sensor connected. Otherwise, zero is output                                                                                                                                          |
| INDOOR_HUM      | Both   | Input  | Input allowing display of indoor humidity on the front panel. Importing the value this way is required only if setup was a TSTAT with non-humidity remotes (no way of measuring indoor humidity). The network input value is overridden by a measured value if one is available |

*Humidifier Related Joins (continued)*

| Signal Name        | Symbol   | I/O    | Definition                                                                                                                                                                                                                                                                                      |
|--------------------|----------|--------|-------------------------------------------------------------------------------------------------------------------------------------------------------------------------------------------------------------------------------------------------------------------------------------------------|
| OUTDOOR_HUMID_F    | Both     | Output | Analog value that is output if a connected remote temperature/humidity sensor is declared as "outdoor" Can be used to distribute the reading to other thermostats for display purposes                                                                                                          |
| REGULATION_HUMID_F | Both     | Output | The "regulation" humidity that a thermostat is using, This is the average of the humidity sensor inputs declared "use" in set-up. This output is only active when a thermostat setup has humidity sensing capability, either by being a CHV-THSTAT or a CHV-TSTAT with humidity remote (Analog) |
| BUILT_IN_HUMID_F   | Advanced | Output | Humidity value of built-in sensor (Analog) Output will send out the sensor values even if the sensor is declared, "omit"                                                                                                                                                                        |
| REM1_HUMID_F       | Advanced | Output | Humidity value of remote 1 sensor (Analog) Output will be zero if the sensor is not installed Output will send out the sensor values even if the sensor is declared "omit"                                                                                                                      |
| REM2_HUMID_F       | Advanced | Output | Humidity value of remote 2 sensor (Analog) Output will be zero if the sensor is not installed Output will send out the sensor values even if the sensor is declared "omit"                                                                                                                      |

*HVAC Related Analog Joins*

**NOTE:** All temperatures except for setpoint values are expressed in tenths of degrees. For example: sending 703 means 70.3.

| Signal Name    | Symbol | I/O    | Definition                                                                                                                                                                                                                                                                                                                                                                                                                |
|----------------|--------|--------|---------------------------------------------------------------------------------------------------------------------------------------------------------------------------------------------------------------------------------------------------------------------------------------------------------------------------------------------------------------------------------------------------------------------------|
| SETPOINT_1     | Both   | Input  | The primary setpoint value, in whole numbers, Example: 71 means the setpoint is 71 degrees, It is the value used in heat, cool, and "aux heat only" modes, When operating in auto mode, setpoint_1 can mean two things, depending on setup, If the option "dual setpoint auto" is Yes, then setpoint is the heat setpoint If No is selected, then setpoint is the only setpoint (single-point auto only has one setpoint) |
| SETPOINT_1_F   | Both   | Output | Output of setpoint 1, in whole numbers                                                                                                                                                                                                                                                                                                                                                                                    |
| SETPOINT_2     | Both   | Input  | Secondary setpoint value, which is ONLY used as the cooling setpoint in auto when "Dual setpoint auto" is selected as Yes                                                                                                                                                                                                                                                                                                 |
| SETPOINT_2_F   | Both   | Output | Output of setpoint 2, in whole numbers                                                                                                                                                                                                                                                                                                                                                                                    |
| OUTDOOR_TEMP   | Both   | Input  | Input that allows the outdoor temperature value to be retrieved from Cresnet for display on the "outdoor" page, This value is ignored when a thermostat has a remote-outdoor sensor connected to it Also used for balance point action on heat pump systems, in 10ths of degrees                                                                                                                                          |
| OUTDOOR_TEMP_F | Both   | Output | Output used for sending outdoor temperature to other units, it takes the value of remote sensors declared "OD"(Outdoor) Output is zero if no remotes are declared "OD", in 10ths of degrees                                                                                                                                                                                                                               |

*HVAC Related Analog Joins (continued)*

| Signal Name       | Symbol   | I/O    | Definition                                                                                                                                                           |
|-------------------|----------|--------|----------------------------------------------------------------------------------------------------------------------------------------------------------------------|
| REGULATION_TEMP_F | Both     | Output | Temperature used for regulation, this is the mean (averaged) temperature for all sensors declared "use", in 10ths of degrees                                         |
| BUILT_IN_TEMP_F   | Advanced | Output | Temperature of the built-in sensor, in 10ths of degree, Note that the values are reported regardless of the use/OD/omit setting                                      |
| REM1_TEMP_F       | Advanced | Output | Temperature of remote 1 sensor, in 10ths of degree<br>Unconnected sensors are reported as 0, Note that the values are reported regardless of the use/OD/omit setting |
| REM2_TEMP_F       | Advanced | Output | Temperature of remote 2 sensor, in 10ths of degree<br>Unconnected sensors are reported as 0, Note that the values are reported regardless of the use/OD/omit setting |

*Indirect Text Joins (Serial)*

| Signal Name    | Symbol   | I/O   | Definition                                                                                 |
|----------------|----------|-------|--------------------------------------------------------------------------------------------|
| MESSAGE        | Advanced | Input | Used for sending a message to the thermostat Appears on the "messages" view screen         |
| BUTTON_LABEL_1 | Advanced | Input | Provides the soft button label for the first remote function button (up button, page 1)    |
| BUTTON_LABEL_2 | Advanced | Input | Provides the soft button label for the second remote function button (down button, page 1) |
| BUTTON_LABEL_3 | Advanced | Input | Provides the soft button label for the third remote function button (up button, page 2)    |
| BUTTON_LABEL_4 | Advanced | Input | Provides the soft button label for the fourth remote function button (down button, page 2) |

*Advanced Setup Related Analog Joins*

| Signal Name          | Symbol   | I/O    | Definition                                                                                              |
|----------------------|----------|--------|---------------------------------------------------------------------------------------------------------|
| HEAT_ANTICIPATOR_F   | Advanced | Output | Heat anticipator value, 1-6 (refer to page 19)                                                          |
| COOL_ANTICIPATOR_F   | Advanced | Output | Cooling anticipator value, 1-6 (refer to page 19)                                                       |
| AUTO_MODE_DEADBAND_F | Advanced | Output | Auto mode deadband value, 2-6 degrees (refer to page 19)                                                |
| HP_BALANCE_PT_F      | Advanced | Output | Heat pump balance point, 0-90°F (refer to page 19)                                                      |
| AUX_BALANCE_PT_F     | Advanced | Output | Aux balance point, 0-90°F (refer to page 19)                                                            |
| LCD_CONTRAST_F       | Advanced | Output | LCD contrast value, 1-10                                                                                |
| TEMP_DISP_OFFSET_F   | Advanced | Output | Offset to be added to measured temperature value to correct display to user preference, -6 - +6 degrees |

*Setup Related Digital Joins*

| Signal Name     | Symbol   | I/O    | Definition                                                           |
|-----------------|----------|--------|----------------------------------------------------------------------|
| HEAT_COOL_SYS_F | Advanced | Output | Asserted when the system is heat/cool type (as opposed to heat pump) |
| HEATPUMP_SYS_F  | Advanced | Output | Asserted when system type is heat pump                               |

*Setup Related Digital Joins (continued)*

| Signal Name         | Symbol   | I/O    | Definition                                                                                                                                                                                                                                                             |
|---------------------|----------|--------|------------------------------------------------------------------------------------------------------------------------------------------------------------------------------------------------------------------------------------------------------------------------|
| DUAL_FUEL_HP_F      | Advanced | Output | Asserted when dual-fuel heat pump system declared, In conventional heat pump systems, aux heat may be used to supplement heat pump heat. In dual-fuel setups, the aux heat output runs in place of the heat pump in cold weather. Requires outdoor temperature sensor. |
| RADIANT_F           | Advanced | Output | Asserted when a heat/cool system is declared as Radiant, Radiant systems require slightly different control characteristics than forced air systems                                                                                                                    |
| FAN_IN_HEAT_F       | Advanced | Output | Asserted when "Run Fan in Heat" is "yes", Most heating systems control the fan if it is needed, but some systems may require the fan to be controlled by the thermostat                                                                                                |
| HEAT_1_STG_F        | Advanced | Output | Asserted when one stage of heat is defined                                                                                                                                                                                                                             |
| HEAT_2_STG_F        | Advanced | Output | Asserted when two stages of heat are defined                                                                                                                                                                                                                           |
| COOL_1_STG_F        | Advanced | Output | Asserted when one stage of cooling is defined                                                                                                                                                                                                                          |
| COOL_2_STG_F        | Advanced | Output | Asserted when two stages of cooling are defined                                                                                                                                                                                                                        |
| TEMP_IN_F           | Advanced | Output | Asserted when Fahrenheit units are used                                                                                                                                                                                                                                |
| TEMP_IN_C           | Advanced | Output | Asserted when Celsius units are used                                                                                                                                                                                                                                   |
| DISP_FP_HUM_F       | Advanced | Output | Asserted when front panel object is set to be humidity                                                                                                                                                                                                                 |
| DISP_FP_OD_F        | Advanced | Output | Asserted when front panel object is outdoor temperature                                                                                                                                                                                                                |
| DISP_HUM_F          | Advanced | Output | Asserted when humidity pages are enabled                                                                                                                                                                                                                               |
| DISP_GLOBAL_F       | Advanced | Output | Asserted when global update page is enabled                                                                                                                                                                                                                            |
| DISP_OUTDOOR_F      | Advanced | Output | Asserted when outdoor page is enabled                                                                                                                                                                                                                                  |
| DISP_REM_BUTTONS1_F | Advanced | Output | Asserted when remote button page 1 is enabled                                                                                                                                                                                                                          |
| DISP_REM_BUTTONS2_F | Advanced | Output | Asserted when remote button page 2 is enabled                                                                                                                                                                                                                          |
| DUAL_SP_AUTO_MODE_F | Advanced | Output | Asserted when using 2 point auto mode, unasserted means using single point auto mode                                                                                                                                                                                   |
| LOW_TEMP_HUM_COMP_F | Advanced | Output | Asserted when low temperature humidity compensation is enabled, helps prevent condensation on windows in cold weather                                                                                                                                                  |

*Sensor Setup Related Digital Joins*

| Signal Name     | Symbol   | I/O    | Definition                                                                  |
|-----------------|----------|--------|-----------------------------------------------------------------------------|
| USE_LOC_TEMP_F  | Advanced | Output | Asserted when using built in temperature sensor                             |
| USE_R1_TEMP_F   | Advanced | Output | Asserted when using remote 1 temperature sensor                             |
| USE_R2_TEMP_F   | Advanced | Output | Asserted when using remote 2 temperature sensor                             |
| OMIT_LOC_TEMP_F | Advanced | Output | Asserted when Omitting built in temperature sensor                          |
| OMIT_R1_TEMP_F  | Advanced | Output | Asserted when Omitting remote 1 temperature sensor                          |
| OMIT_R2_TEMP_F  | Advanced | Output | Asserted when Omitting remote 2 temperature sensor                          |
| R1_T_OUTDOOR_F  | Advanced | Output | Asserted when remote 1 temperature sensor has been declared as outdoor (OD) |
| R2_T_OUTDOOR_F  | Advanced | Output | Asserted when remote 2 temperature sensor has been declared as outdoor (OD) |
| USE_LOC_HUM_F   | Advanced | Output | Asserted when using built in humidity sensor (THSTAT)                       |
| USE_R1_HUM_F    | Advanced | Output | Asserted when using remote 1 humidity sensor                                |

*Sensor Setup Related Digital Joins (continued)*

| Signal Name    | Symbol   | I/O    | Definition                                          |
|----------------|----------|--------|-----------------------------------------------------|
| USE_R2_HUM_F   | Advanced | Output | Asserted when using remote 2 humidity sensor        |
| OMIT_LOC_HUM_F | Advanced | Output | Asserted when Omitting built in hum sensor (THSTAT) |
| OMIT_R1_HUM_F  | Advanced | Output | Asserted when Omitting remote 1 humidity sensor     |
| OMIT_R2_HUM_F  | Advanced | Output | Asserted when Omitting remote 2 humidity sensor     |
| R1_H_OUTDOOR_F | Advanced | Output | Asserted when remote 1 humidity sensor is outdoor   |
| R2_H_OUTDOOR_F | Advanced | Output | Asserted when remote 2 humidity sensor is outdoor   |

**Example Programs**

Example programs for the thermostat are available from the Crestron FTP site (<ftp://ftp.crestron.com>). Select the Examples Folder and search for: CHV-THSTAT sample with scheduler.zip.

**Viewport ID String**

In Viewport, the thermostats output a string of characters that describe the setup and configuration of the thermostat. Refer to the following table for an explanation of this string. Each element of the setup string is separated by a period. The following are two examples of ID strings:

2A: CHV-THSTAT [v1.0] (HP.H2.C2.HA3.CA3.ADB2.H,Abp0,90.AX.F.L5.OS0.DA.UUDDUU)  
 2B: CHV-THSTAT [v1.0] (H/C.H1.C1.HA3.CA3.ADB2.FA.F.L5.OS0.DA.UUOOOO)

*ID Strings*

| Function                     | Options         | Description                                                                                                                                                                  |
|------------------------------|-----------------|------------------------------------------------------------------------------------------------------------------------------------------------------------------------------|
| System type                  | H/C, HP         | Heat/cool or heat pump system                                                                                                                                                |
| Heat stages                  | H1, H2          | Number of heating stages, 1 or 2                                                                                                                                             |
| Cool stages                  | C1, C2          | Number of cooling stages, 1 or 2                                                                                                                                             |
| Heat anticipator             | HA1 - HA6       | Heat anticipator setting, from 1-6                                                                                                                                           |
| Cool anticipator             | CA1 - CA6       | Cooling anticipator setting, from 1 - 6                                                                                                                                      |
| Auto-mode deadband           | ADB2 - ADB6     | Minimum separation between heat and cool setpoints in auto mode, degrees, 2 - 6                                                                                              |
| Heat/cool system subtype     | RAD, FA         | Sub-type of heat/cool heating system RADiant or Forced Air                                                                                                                   |
| Heat pump system subtype     | AX, DF          | Indicates heat pump system subtype as either AuXiliary heat or a Dual-Fuel system                                                                                            |
| Heat pump/aux balance points | 0 - 90 for both | Indicates the heat pump and aux heat balance points in current temperature unit                                                                                              |
| Temperature unit             | F, C            | Fahrenheit or Celsius                                                                                                                                                        |
| LCD contrast                 | L0-L10          | LCD contrast setting                                                                                                                                                         |
| Temperature offset (null)    | OS-6 - OS6      | Indicates the display temperature offset, from -6 to 6 degrees                                                                                                               |
| Auto mode operation          | DA, SA          | Indicates auto mode as dual setpoint (heat, cool setpoint) or single setpoint mode                                                                                           |
| Sensor usage flags           | U,D,O           | Indicates the status of each sensor input: Use, outDoor, or Omit, sensor series is as follows:<br>buit-in-temp; built-humidity; rem 1 temp; rem1 hum; rem 2 temp; rem 2 hum. |

**NOTE:** Depending on system type, not all of the options above will be present.



## Problem Solving

### Troubleshooting

The table below provides corrective action for possible trouble situations. If further assistance is required, please contact a Crestron customer service representative.

#### *CHV-TSTAT/CHV-THSTAT Troubleshooting*

| TROUBLE                                               | POSSIBLE CAUSE(S)                                                                                     | CORRECTIVE ACTION                                                                                                                                               |
|-------------------------------------------------------|-------------------------------------------------------------------------------------------------------|-----------------------------------------------------------------------------------------------------------------------------------------------------------------|
| No display                                            | No power from system                                                                                  | Check for +24V on pins 24(C) and 24(R)                                                                                                                          |
|                                                       | Incorrect mounting to backplate                                                                       | Check thermostat mounting                                                                                                                                       |
| Heating/Cooling system not operating*                 | No power to thermostat                                                                                | Check circuit breaker<br>Check 24V connection at thermostat and at furnace/air conditioner<br>Recheck wiring connections                                        |
|                                                       | Thermostat minimum off times operating both systems                                                   | Wait 5 minutes and/or consult HVAC contractor                                                                                                                   |
| Indicator displays Heat On, but no heat from register | Fan turns on when furnace reaches setpoint                                                            | Wait five minutes, then recheck registers.<br>Setpoint heat range is 38 – 90° F (3-38° C).                                                                      |
| Cannot change temperature setting                     | The upper or lower temperature limits were reached.                                                   | Setpoint cool range is 59-100° F (15 – 38° C)                                                                                                                   |
| Furnace cycles too quickly                            | Anticipator setting too high                                                                          | Reprogram anticipator. Refer to “Thermostat Setup” on page 16                                                                                                   |
| High temperature variance                             | Anticipator setting too low                                                                           | Reprogram anticipator. Refer to “Thermostat Setup” on page 16                                                                                                   |
| Displays “Sensor Error” and thermostat is locked-up   | All temperature sensors are disabled or have failed                                                   | Remove the thermostat from the backplate and reinsert while simultaneously pressing and holding the <b>MODE</b> and <b>DOWN</b> buttons to return to Setup Mode |
| Displays “NetDown”                                    | No Crestron program or the program does not have a device at this net address included in this system | Fix program, if one is needed                                                                                                                                   |

\*H1, H2, C1, C2 may appear but the system will not activate until the 5 minute timer guards have been satisfied.

## Further Inquiries

If after reviewing this Operations and Installation Guide, you cannot locate specific information or have questions, please take advantage of Crestron's award winning customer service team by calling:

- In the US and Canada, call Crestron's corporate headquarters at 1-888-CRESTRON [1-888-273-7876].
- In Europe, call Crestron International at +32-15-50-99-50.
- In Asia, call Crestron Asia at +852-2341-2016.
- In Latin America, call Crestron Latin America at +5255-5093-2160.
- In Australia and New Zealand, call Creston Pacific at +613-9480-2999

## Firmware Upgrades

To take advantage of all the features, it is important that the unit contains the latest firmware available. Therefore, please check Crestron's website ([http://www.crestron.com/downloads/software\\_updates.asp](http://www.crestron.com/downloads/software_updates.asp)) for the latest version of firmware. Not every product has a firmware upgrade, but as Crestron improves functions, adds new features, and extends the capabilities of its products, firmware upgrades are posted. If you have questions regarding upgrades procedures, contact Crestron customer service.

## Future Updates

As Crestron improves functions, adds new features, and extends the capabilities of this product, additional information may be made available as manual updates. These updates are solely electronic and serve as intermediary supplements prior to the release of a complete technical documentation revision.

Check the Crestron website ([www.crestron.com](http://www.crestron.com)) periodically for manual update availability and its subjective value. Updates are available from the Download | Product Manuals section and are identified as an "Addendum" in the Download column.

---

## Appendix A: Glossary

- Anticipators** – Used to anticipate the drop or rise in temperature and energize the appropriate system before reaching the set point.
- Balance Point** – The lowest outdoor temperature at which the refrigeration cycle of a heat pump will supply the heating requirements without the aid of a supplementary heat source.
- Blower (Fan)** – An air-handling device for moving air in a distribution system.
- BTU - British Thermal Unit** – In scientific terms, it represents the amount of energy required to raise one pound of water one degree Fahrenheit. One BTU is the equivalent of the heat given off by a single wooden kitchen match.
- Call** – A call is when the thermostat requests the heating or cooling system to turn on.
- Damper** – Found in ductwork, this movable plate opens and closes to control airflow. Dampers are used effectively in zoning to regulate airflow to certain rooms.
- Dead Band** – The minimal differential between Heating and Cooling.
- Dual Fuel** – A heat pump used in conjunction with an existing furnace.
- Emergency Heat (Supplementary Electric Heat)** – The auxiliary or emergency heat provided at temperatures below a heat pump's balance point. It is usually electrical resistance heat.
- Forced Air** – A type of heating system that uses a blower motor to move air through the furnace and into the ductwork.
- Furnace** – Equipment used to convert heating energy, such as fuel, oil, gas or electricity, to usable heat. It usually contains a heat exchanger, a blower and the controls to operate the system.
- Heat Exchanger** – A device for the transfer of heat energy from the source to the conveying medium of air or water. Most common combinations are: Refrigerant to air or Refrigerant to water (DX), Water to air (hydronic), Steam to air, Steam to water.
- Heat Pump** – A unit that both cools and heats. A heat pump system can be either a split system or a packaged system. A heat pump can be used in conjunction with a gas/oil/LP furnace (using the furnace instead of electric resistance heat when temperatures fall below about 35° F).
- Humidity** – The total amount of moisture in air. Relative humidity (RH) is the amount of moisture in air, relative to its total capability based upon its temperature (dewpoint). Moisture will condense on surfaces that are below this dewpoint.
- HVAC** – Heating, ventilation and air conditioning.
- Setpoint** – The thermostat temperature set to begin heating or cooling.
- Time Delay (Timer Guards)** – Refers to a safety device or circuit that will not allow restart for 5 minutes.
- Two Stage Heating** – The heating unit starts out running in its first stage, and operates at about 68% of its capacity. When the temperature outside goes very low, the system adjusts to full capacity (second stage) to meet the demand.

---

## Appendix B: About Heat Pumps

A heat pump extracts available heat from one area and transfers it to another. Even cold air contains some heat, and heat pumps can extract heat from the outside air on a cold day and transfer it indoors to maintain a comfortable temperature. A heat pump also works in reverse during the summer, extracting heat from indoors and transferring it outdoors.

In the heating mode, the efficiency of a heat pump decreases as the outdoor air temperature decreases.

### *Heat Pump Operation*

Heat flows naturally from a warm area to a cooler area, and the heat pump takes advantage of this principle. The heat pump essentially consists of a compressor, an inside coil and fan, and an outside coil and fan. A refrigerant flows inside the coils, under pressure applied by the compressor.

The refrigerant boils at a very low temperature (as low as -15° F) and becomes a vapor, just as water becomes a vapor (steam) when boiled. This vapor is sucked into the compressor where it becomes a high pressure, high temperature vapor.

When heating, the refrigerant is then forced through a coil within part of the heat pump located indoors. A fan blows cool air over the coil, the vapor cools, turns back to a liquid, releasing heat that is blown through a duct system to heat the house.

The cycle begins again as the cooled liquid refrigerant is pumped back outside after releasing its heat. On the way, it passes through an expansion valve, lowering the refrigerant's pressure and temperature again so it can boil more easily in the outdoor coil.

In its cooling mode the heat pump system works in reverse, extracting available heat from indoors and transferring it outside.

Heat pumps are most economical when they can be used year-round for both winter heating and summer cooling.

The efficiency of a heat pump varies significantly with the outdoor temperature. While a heat pump may be twice as efficient as a conventional heating system at 50°F. When the outdoor temperature drops to less than 30°F, the heat pump must be supplemented with an auxiliary heating system such as electric resistance. At temperatures of 15°F or less the heat pump may shut off and the backup heating system takes over. This is the heat pump balance point. In a dual-fuel system, the heat pump is supplemented with a standard furnace, which takes over when it becomes more efficient than the heat pump at very low temperatures.

---

## Return and Warranty Policies

### Merchandise Returns / Repair Service

1. No merchandise may be returned for credit, exchange, or service without prior authorization from CRESTRON. To obtain warranty service for CRESTRON products, contact the factory and request an RMA (Return Merchandise Authorization) number. Enclose a note specifying the nature of the problem, name and phone number of contact person, RMA number, and return address.
2. Products may be returned for credit, exchange, or service with a CRESTRON Return Merchandise Authorization (RMA) number. Authorized returns must be shipped freight prepaid to CRESTRON, Cresskill, N.J., or its authorized subsidiaries, with RMA number clearly marked on the outside of all cartons. Shipments arriving freight collect or without an RMA number shall be subject to refusal. CRESTRON reserves the right in its sole and absolute discretion to charge a 15% restocking fee, plus shipping costs, on any products returned with an RMA.
3. Return freight charges following repair of items under warranty shall be paid by CRESTRON, shipping by standard ground carrier. In the event repairs are found to be non-warranty, return freight costs shall be paid by the purchaser.

### CRESTRON Limited Warranty

CRESTRON ELECTRONICS, Inc. warrants its products to be free from manufacturing defects in materials and workmanship under normal use for a period of three (3) years from the date of purchase from CRESTRON, with the following exceptions: disk drives and any other moving or rotating mechanical parts, pan/tilt heads and power supplies are covered for a period of one (1) year; touchscreen display and overlay components are covered for 90 days; batteries and incandescent lamps are not covered.

This warranty extends to products purchased directly from CRESTRON or an authorized CRESTRON dealer. Purchasers should inquire of the dealer regarding the nature and extent of the dealer's warranty, if any.

CRESTRON shall not be liable to honor the terms of this warranty if the product has been used in any application other than that for which it was intended, or if it has been subjected to misuse, accidental damage, modification, or improper installation procedures. Furthermore, this warranty does not cover any product that has had the serial number altered, defaced, or removed.

This warranty shall be the sole and exclusive remedy to the original purchaser. In no event shall CRESTRON be liable for incidental or consequential damages of any kind (property or economic damages inclusive) arising from the sale or use of this equipment. CRESTRON is not liable for any claim made by a third party or made by the purchaser for a third party.

CRESTRON shall, at its option, repair or replace any product found defective, without charge for parts or labor. Repaired or replaced equipment and parts supplied under this warranty shall be covered only by the unexpired portion of the warranty.

Except as expressly set forth in this warranty, CRESTRON makes no other warranties, expressed or implied, nor authorizes any other party to offer any warranty, including any implied warranties of merchantability or fitness for a particular purpose. Any implied warranties that may be imposed by law are limited to the terms of this limited warranty. This warranty statement supercedes all previous warranties.

#### Trademark Information

*All brand names, product names, and trademarks are the sole property of their respective owners. Windows is a registered trademark of Microsoft Corporation. Windows95/98/Me/XP and WindowsNT/2000 are trademarks of Microsoft Corporation.*

This page intentionally left blank.

This page intentionally left blank



**Crestron Electronics, Inc.**  
15 Volvo Drive Rockleigh, NJ 07647  
Tel: 888.CRESTRON  
Fax: 201.767.7576  
[www.crestron.com](http://www.crestron.com)

**Operations and Installation Guide – DOC. 8163A**  
**04.03**

Specifications subject to  
change without notice.