



Wireless Door Chime Kit

Installation Instructions for Battery Operated Wireless Door Chime Kit

Prior to Installation the Try-Me feature must be removed.

1. Remove the battery cover on the chime.
2. Remove the white Styrofoam block
3. Unplug the red and black wires inside the battery compartment.
4. Remove the battery pack and discard appropriately.

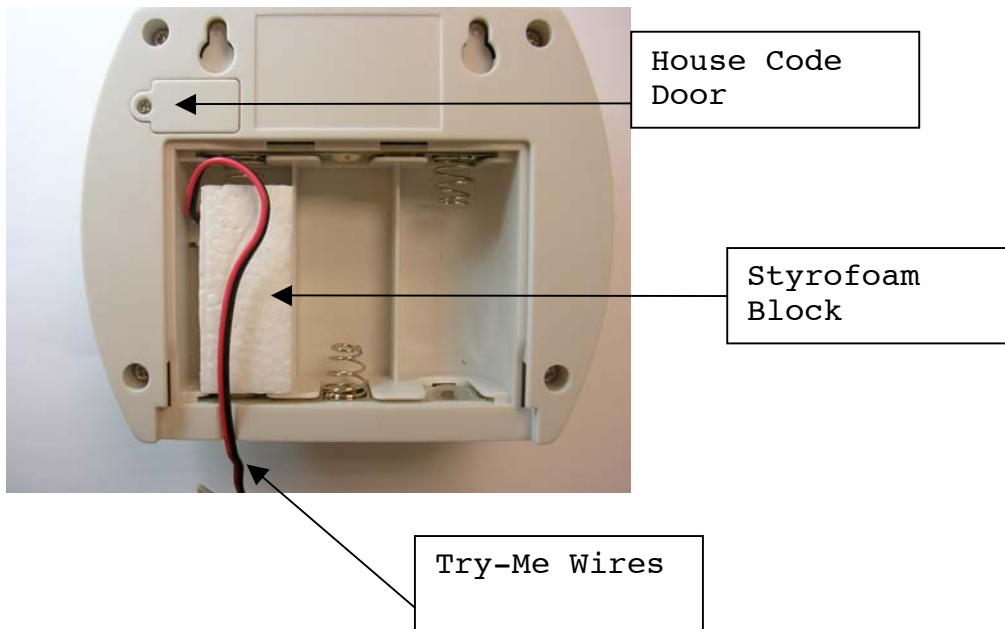

Chime components

Required Tools: Small flat blade screwdriver, drill, 1/16" and 5/32" drill bits, and phillips screwdriver.

Included Hardware:

- (2) Plastic screw anchors
- (2) 4x20mm screws
- (2) 3x20mm screws
- (2) Double sided adhesive pads

The wireless door chime Kit has two components:

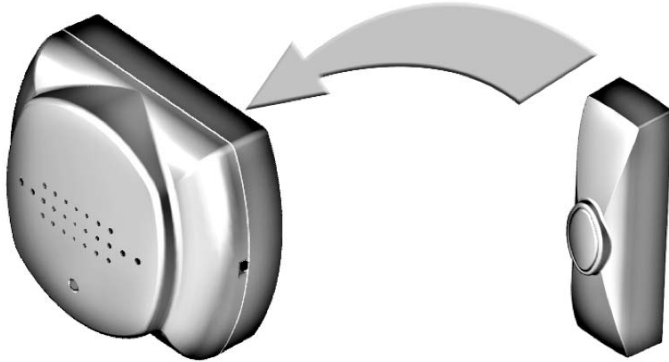

Chime (receiver)

Push-Button (Transmitter).

Chime Tune Setting

All wireless chimes may have more than one push button. The chime tune for each push button is set with dip switches 1-3.

Single Push Button Kit: If you purchased a kit with a single push button, the chime tune will be set to Ding Dong from the factory.

Dual Push Button Kit: If you purchased a kit with two push buttons, one push button will be set to Ding Dong and the other push button will be set to Westminster from the factory.

The following instructions explain how to change the tune on any wireless push button.

1. Remove the battery from the push button transmitter.
2. Locate the 3 dip switches shown below.
3. Select the desired chime sound from the table below.

Chime Sound Table

Position	1	2	3
Westminster	ON	OFF	OFF
Ding Dong	OFF	ON	OFF
Knock	OFF	OFF	ON
Bronze Chime	ON	ON	OFF
Cuckoo Clock	ON	OFF	ON
Foghorn	OFF	ON	ON
Gong	ON	ON	ON

ON: Switch On

OFF: Switch Off

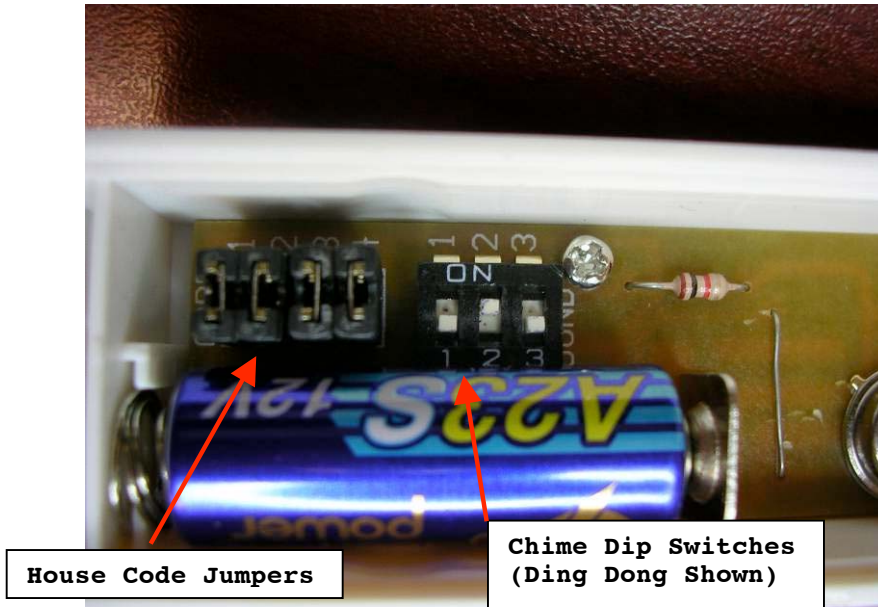

Pushbutton Dip Switches and Jumpers

Setting The House Security Code

Each chime component has 4 jumpers for setting the house security code. In most cases you will not need to change the factory settings for the house security code. If your chime activates intermittently or does not work at all, you may be able to solve the problem by changing your security code.

1. Remove power or batteries from the chime.
2. To remove the batteries from the pushbutton, open the pushbutton case as shown below.

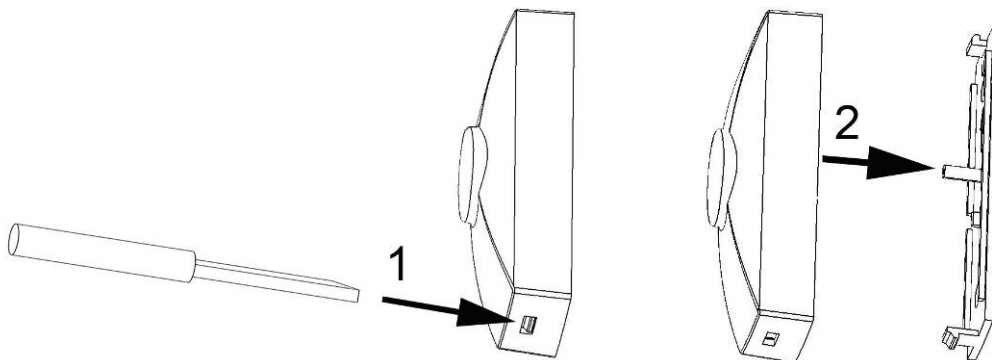

3. Locate the House Security Code door and screw located on the back of the chime (See the chime components picture above). Remove the screw and take off the door.
4. Locate the chime and pushbutton jumpers shown below.

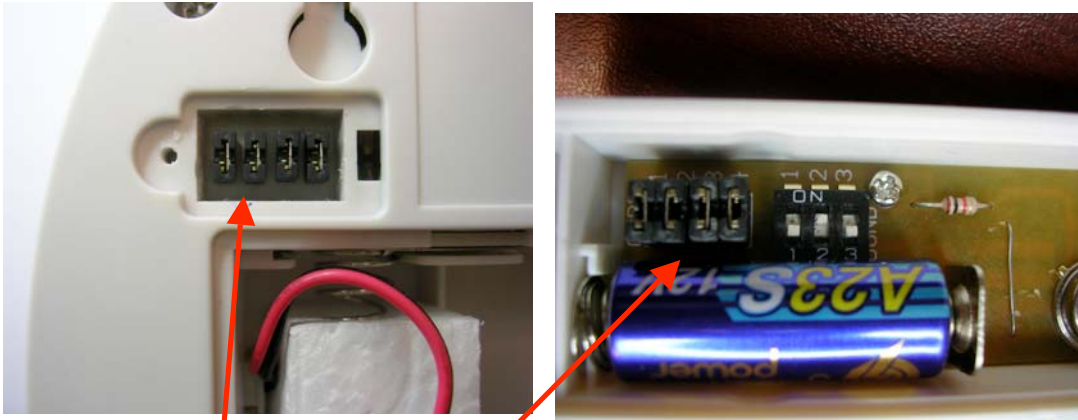

House Code Jumpers

Chime and Pushbutton Jumpers

5. To change the house code, add or remove jumpers as needed. It is recommended to change only one jumper at a time and then test the system for proper operation. The jumpers on the chime and pushbutton must match exactly.

Push Button Mounting Instructions

Note: Avoid mounting on metal surfaces, as it may result in a reduced range of transmission. Do not mount in an area where exposed to direct rain.

a. Removing the back cover

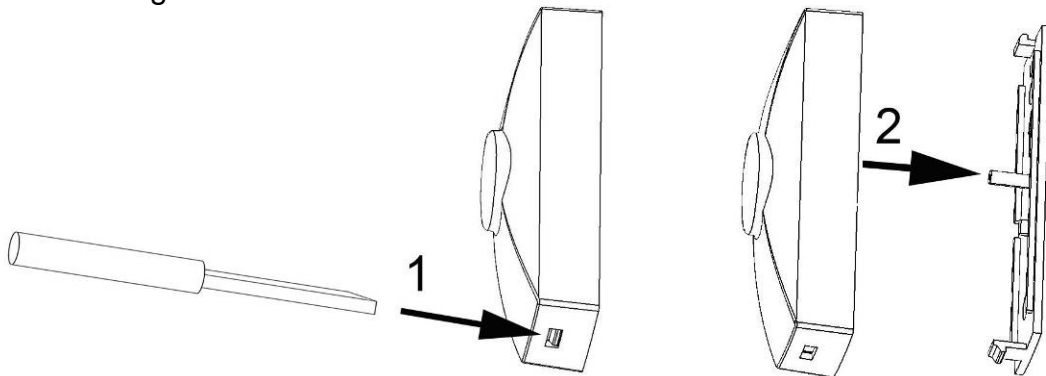

b. Replacing the back cover

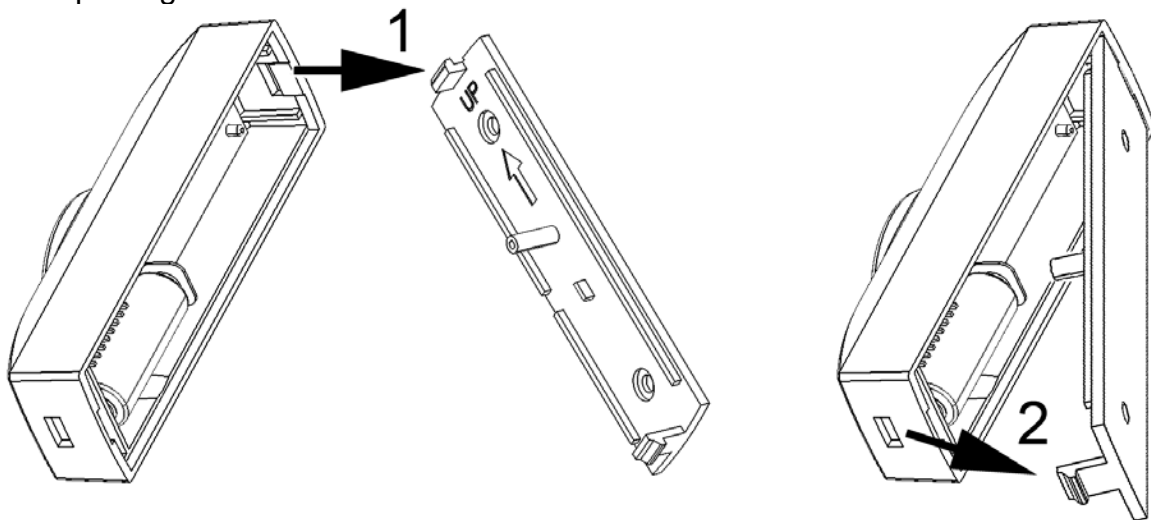

1. Push buttons are typically mounted at the same height as the door knob or handle (between 36" and 44" above the floor).
2. Before mounting, choose a mounting location that is not farther than 150 feet from the chime unit location.

Not farther than 150 feet

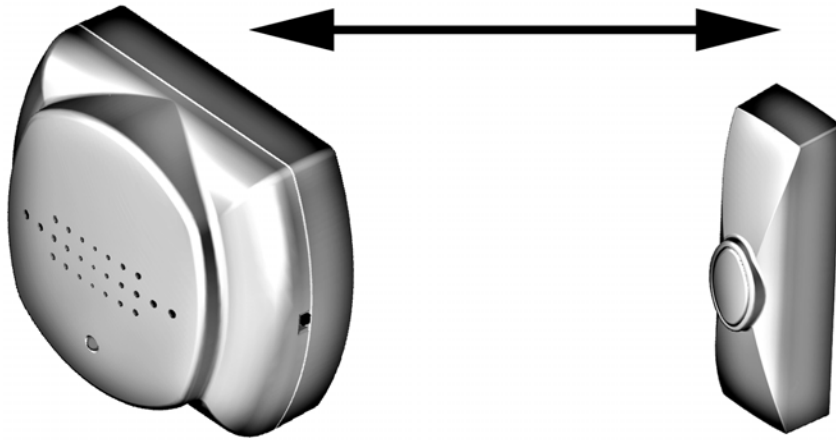

Place push button where you would like to mount and test operation with the chime as close to it's final location as possible. If it works, mount button here. If it does not work, see TROUBLESHOOTING.

3. Use back cover of push button as a template to mark two screw holes.

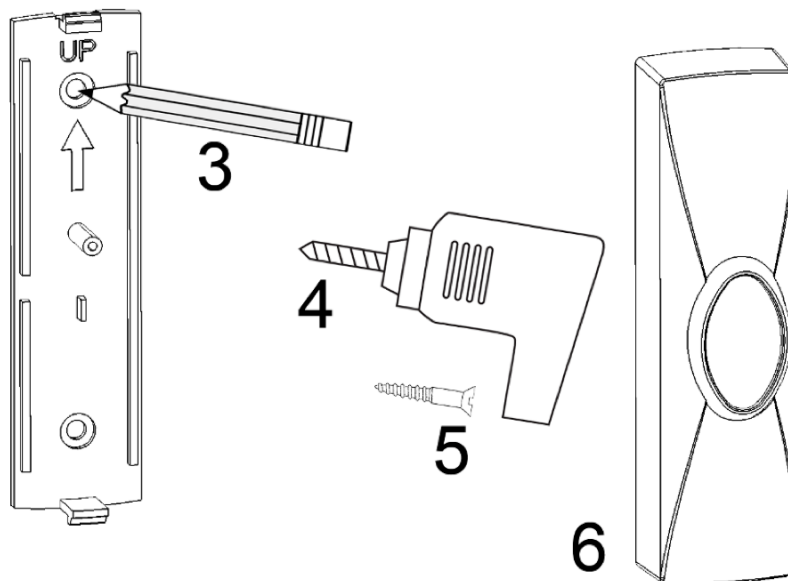

4. Drill two holes with 1/16" drill in marked locations.
5. Secure back cover to the mounting surface with the 3x20mm screws.
6. Press front housing onto back cover.

7. Test Operations, if chime does not work, see TROUBLESHOOTING.

Chime Unit Mounting Instructions

Note: Avoid mounting on metal surfaces, as it may result in a reduced range of transmission.

1. Select chime mounting location.
2. Use the supplied chime template to mark mounting holes.
3. Drill 5/32" holes at marked locations.
4. Insert supplied wall anchors into the holes.
5. Insert the 4/20mm screws into the anchors, setting the screw heads extending about 1/4" from mounting surface.

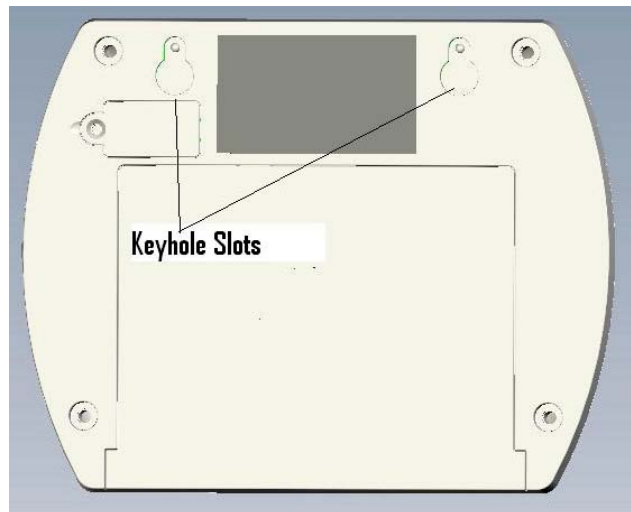

6. Place the chime unit's keyhole slots over the screws and press down on the chime unit to secure it.

Operation

1. Slide power switch to “On” to turn on the chime.

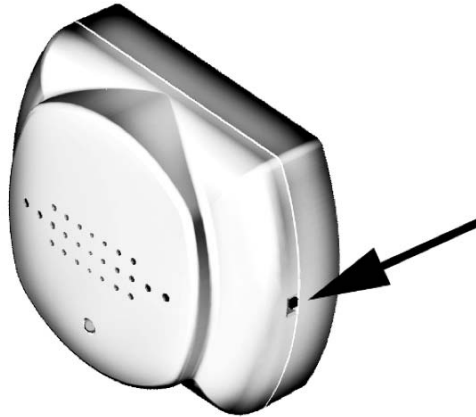

2. Gently press transmitter button to sound chime.

Troubleshooting

Chime doesn't work:

1. Make sure push button switch is depressed and held for at least 1 second.
2. Make sure house code switches 1-4 on chime and push button match exactly.
3. Verify battery orientation in push button.
4. Try fresh batteries.
5. Make sure chime is not farther than 150 feet away from push button.
6. Ensure push button is not mounted on metal, near metal studs, or near the Floor.
7. Try a new location for the chime.

Functional range may be adversely affected by one or more of the following factors: weather, radio frequency interference, low transmitter battery and obstructions between the transmitter and receiver.

This device complies with Part 15 of the FCC rules. Operation is subject to the following conditions:

1. This device may not cause harmful interference, and
2. This device must accept interference received, including any interference that may cause undesired operation.

**For technical support contact Jasco Products Company at 1-800-654-8483
or www.jascoproducts.com**

Made in China
Hecho en China



is a trademark of
General Electric Company
and is used under license to
Jasco Products Company LLC,
10 E. Memorial Road,
Oklahoma City, OK 73114.
www.jascoproducts.com

Rev. 4-07

19208