

Grizzly *Industrial, Inc.*®

OSCILLATING BELT EDGE SANDER MODEL G9984/G9985 INSTRUCTION MANUAL



COPYRIGHT © APRIL 2002 BY GRIZZLY INDUSTRIAL, INC.
**WARNING: NO PORTION OF THIS MANUAL MAY BE REPRODUCED IN ANY SHAPE
OR FORM WITHOUT THE WRITTEN APPROVAL OF GRIZZLY INDUSTRIAL, INC.**
PRINTED IN TAIWAN.

WARNING

Some dust created by power sanding, sawing, grinding, drilling, and other construction activities contains chemicals known to the State of California to cause cancer, birth defects or other reproductive harm. Some examples of these chemicals are:

- Lead from lead-based paints.
- Crystalline silica from bricks, cement, and other masonry products.
- Arsenic and chromium from chemically treated lumber.

Your risk from these exposures varies, depending on how often you do this type of work. To reduce your exposure to these chemicals: work in a well ventilated area, and work with approved safety equipment, such as those dust masks that are specially designed to filter out microscopic particles.

Table Of Contents

	PAGE
1. SAFETY	
SAFETY RULES FOR POWER TOOLS	2-3
ADDITIONAL SAFETY INSTRUCTIONS FOR EDGE SANDERS	4
2. CIRCUIT REQUIREMENTS	
220V SINGLE-PHASE OPERATION	5
220V THREE-PHASE OPERATION	5
GROUNDING	6
EXTENSION CORDS	6
3. INTRODUCTION	
COMMENTARY.....	7
UNPACKING	8-9
PIECE INVENTORY	9
HARDWARE RECOGNITION CHART	10
CLEAN UP.....	11
SITE CONSIDERATION	11
4. ASSEMBLY	
BEGINNING ASSEMBLY	12
RUBBER FEET	12
BASE SUPPORTS	13
5. ADJUSTMENTS	
POWER SWITCH	14
DUST COLLECTION.....	14
SANDING BELT ROTATION.....	15
SANDING BELT REPLACEMENT	15
SANDING BELT TRACKING.....	16
MAIN TABLE HEIGHT.....	16
MAIN TABLE ANGLE	17
MITER GAUGE	17-18
SIDE TABLE HEIGHT	18
SIDE TABLE ANGLE.....	18
6. OPERATIONS	
TEST RUN.....	19
SANDING BELTS	19
7. MAINTENANCE	
GENERAL	20
TABLES.....	20
LUBRICATION.....	20
8. CLOSURE	21
WIRING DIAGRAM	22-23
DATA SHEET.....	24-25
PARTS DIAGRAM AND LIST	26-35
WARRANTY AND RETURNS	38-40

SECTION 1: SAFETY

WARNING

For Your Own Safety Read Instruction Manual Before Operating This Equipment

The purpose of safety symbols is to attract your attention to possible hazardous conditions. This manual uses a series of symbols and signal words which are intended to convey the level of importance of the safety messages. The progression of symbols is described below. Remember that safety messages by themselves do not eliminate danger and are not a substitute for proper accident prevention measures.



Indicates an imminently hazardous situation which, if not avoided, **WILL** result in death or serious injury.



Indicates a potentially hazardous situation which, if not avoided, **COULD** result in death or serious injury.



Indicates a potentially hazardous situation which, if not avoided, **MAY** result in minor or moderate injury. It may also be used to alert against unsafe practices.

NOTICE

This symbol is used to alert the user to useful information about proper operation of the equipment.

WARNING

Safety Instructions For Power Tools

- 1. KEEP GUARDS IN PLACE** and in working order.
- 2. REMOVE ADJUSTING KEYS AND WRENCHES.** Form habit of checking to see that keys and adjusting wrenches are removed from tool before turning on.
- 3. KEEP WORK AREA CLEAN.** Cluttered areas and benches invite accidents.
- 4. DO NOT USE IN DANGEROUS ENVIRONMENT.** Do not use power tools in damp or wet locations, or where any flammable or noxious fumes may exist. Keep work area well lighted.
- 5. KEEP CHILDREN AND VISITORS AWAY.** All children and visitors should be kept a safe distance from work area.
- 6. MAKE WORKSHOP CHILD PROOF** with padlocks, master switches, or by removing starter keys.
- 7. DO NOT FORCE TOOL.** It will do the job better and safer at the rate for which it was designed.
- 8. USE RIGHT TOOL.** Do not force tool or attachment to do a job for which it was not designed.

WARNING

Safety Instructions For Power Tools

9. **USE PROPER EXTENSION CORD.** Make sure your extension cord is in good condition. Conductor size should be in accordance with the chart below. The amperage rating should be listed on the motor or tool nameplate. An undersized cord will cause a drop in line voltage resulting in loss of power and overheating. Your extension cord must also contain a ground wire and plug pin. Always repair or replace extension cords if they become damaged.

Minimum Gauge for Extension Cords

AMP RATING	LENGTH		
	25ft	50ft	100ft
0-6	18	16	16
7-10	18	16	14
11-12	16	16	14
13-16	14	12	12
17-20	12	12	10
21-30	10	10	No

10. **WEAR PROPER APPAREL.** Do not wear loose clothing, gloves, neckties, rings, bracelets, or other jewelry which may get caught in moving parts. Non-slip footwear is recommended. Wear protective hair covering to contain long hair.
11. **ALWAYS USE SAFETY GLASSES.** Also use face or dust mask if cutting operation is dusty. Everyday eyeglasses only have impact resistant lenses, they are NOT safety glasses.
12. **SECURE WORK.** Use clamps or a vise to hold work when practical. It's safer than using your hand and frees both hands to operate tool.
13. **DO NOT OVER-REACH.** Keep proper footing and balance at all times.
14. **MAINTAIN TOOLS WITH CARE.** Keep tools sharp and clean for best and safest performance. Follow instructions for lubricating and changing accessories.
15. **USE RECOMMENDED ACCESSORIES.** Consult the owner's manual for recommended accessories. The use of improper accessories may cause risk of injury.
16. **REDUCE THE RISK OF UNINTENTIONAL STARTING.** On machines with magnetic contact starting switches there is a risk of starting if the machine is bumped or jarred. Always disconnect from power source before adjusting or servicing. Make sure switch is in OFF position before reconnecting.
17. **MANY WOODWORKING TOOLS CAN "KICKBACK" THE WORKPIECE** toward the operator if not handled properly. Know what conditions can create "kickback" and know how to avoid them. Read the manual accompanying the machine thoroughly.
18. **CHECK DAMAGED PARTS.** Before further use of the tool, a guard or other part that is damaged should be carefully checked to determine that it will operate properly and perform its intended function. Check for alignment of moving parts, binding of moving parts, breakage of parts, mounting, and any other conditions that may affect its operation. A guard or other part that is damaged should be properly repaired or replaced.
19. **NEVER LEAVE TOOL RUNNING UNATTENDED. TURN POWER OFF.** Do not leave tool until it comes to a complete stop.
20. **NEVER OPERATE A MACHINE WHEN TIRED, OR UNDER THE INFLUENCE OF DRUGS OR ALCOHOL.** Full mental alertness is required at all times when running a machine.
21. **NEVER ALLOW UNSUPERVISED OR UNTRAINED PERSONNEL TO OPERATE THE MACHINE.** Make sure any instructions you give in regards to machine operation are approved, correct, safe, and clearly understood.
22. **IF AT ANY TIME YOU ARE EXPERIENCING DIFFICULTIES** performing the intended operation, stop using the machine! Then contact our service department or ask a qualified expert how the operation should be performed.

⚠️ WARNING

Additional Safety Instructions For The Oscillating Belt Edge Sander

- **DO NOT** allow anyone to stand near the sander while sanding wood stock.
- **DO NOT** jam the workpiece against the sanding belt. Firmly grasp the workpiece in both hands and ease it against the sanding belt using light pressure.
- **DO NOT** wear loose clothing while operating this machine. Roll up or button sleeves at the cuff.
- **DO NOT** place hands near, or in contact with, sanding belt during operation.
- **ANY PROBLEM**, with the exception of belt tracking, that is concerned at all with any moving parts or accessories must be investigated and corrected with the power disconnected, and after everything has come to a complete stop.
- **PERFORM** machine inspections and maintenance service promptly when called for.
- **NEVER** leave the machine running unattended.
- **REPLACE** sanding belt when it becomes worn.
- **NEVER** sand more than one piece of stock at a time.
- **ALWAYS** inspect board stock for nails, staples, knots, and other imperfections that could be dislodged and thrown from the machine during sanding operations.
- **NEVER** operate the sander without an adequate dust collection system in place and running.
- **NEVER** sand tapered or pointed stock with the point facing the feed direction.

⚠️ CAUTION

No list of safety guidelines can be complete. Every shop environment is different. Always consider safety first, as it applies to your individual working conditions. Use this and other machinery with caution and respect. Failure to follow guidelines could result in serious personal injury, damage to equipment or poor work results.

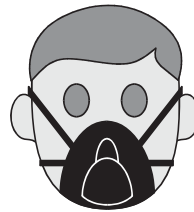

⚠️ CAUTION

Always wear a dust mask when operating the Model G9984/G9985. Using this machine produces sawdust which may cause allergic reactions or respiratory problems.

SECTION 2: CIRCUIT REQUIREMENTS

220V Single-Phase

G9984 Only:

The Model G9984 has a 3 H.P., 1725 R.P.M. motor which requires a 220V single-phase circuit. The cord set included does not have a plug, as the style of plug you require will depend upon the type of service you currently have or plan to install. The motor will safely draw about 16 amps at 220V under load. If you operate the Model G9984 on any circuit that is already close to its capacity, it might blow a fuse or trip a circuit breaker. However, if an unusual load does not exist, and the circuit breaker still trips, have the circuit inspected by a qualified electrician.

In preparing to connect the Model G9984 to your existing or new circuit, it will be necessary to connect a plug that matches your 220V receptacle. If you will be installing a new receptacle and plug, we recommend using a NEMA-style L6-20 plug and outlet shown in **Figure 1**.

The Model G9984 should be fused at 20 amps. Do not attempt to modify an existing circuit by replacing the circuit breaker with one rated for a higher amperage than the plug, outlet and wiring can handle. Make sure that existing electrical wires are capable of handling a 20 amp current. If you are unsure, seek the assistance of a qualified electrician.

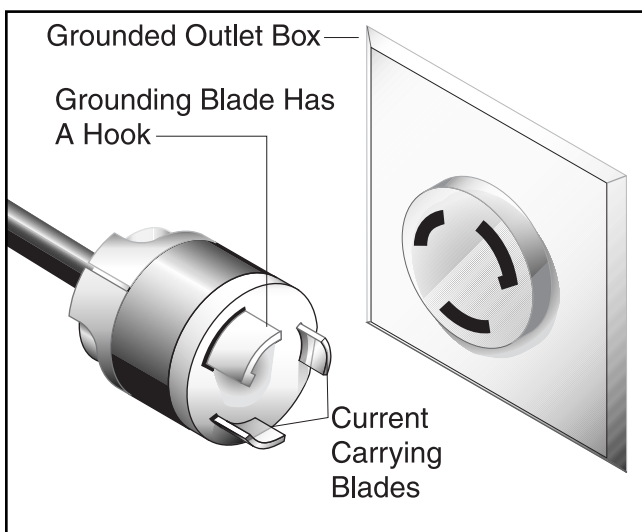

Figure 1. NEMA-style L6-20 plug and outlet.



220V Three-Phase

G9985 Only:

The Model G9985 has a 3 H.P., 1725 R.P.M. motor which requires a 220V three-phase circuit. The cord set enclosed does not have a plug, as the style of plug you require will depend upon the type of service you currently have or plan to install. The motor will safely draw about 9 amps at 220V under load. If you operate the Model G9985 on any circuit that is already close to its capacity, it might blow a fuse or trip a circuit breaker. However, if an unusual load does not exist, and the circuit breaker still trips, have the circuit inspected by a qualified electrician.

In preparing to connect the Model G9985 to your existing or new circuit, it will be necessary to connect a plug that matches your 220V receptacle. If you will be installing a new receptacle and plug, we recommend using a NEMA-style L15-20 plug and outlet shown in **Figure 2**.

The Model G9985 should be fused at 20 amps. Do not attempt to modify an existing circuit by replacing the circuit breaker with one rated for a higher amperage than the plug, outlet and wiring can handle. Make sure that existing electrical wires are capable of handling a 20 amp current. If you are unsure, seek the assistance of a qualified electrician.

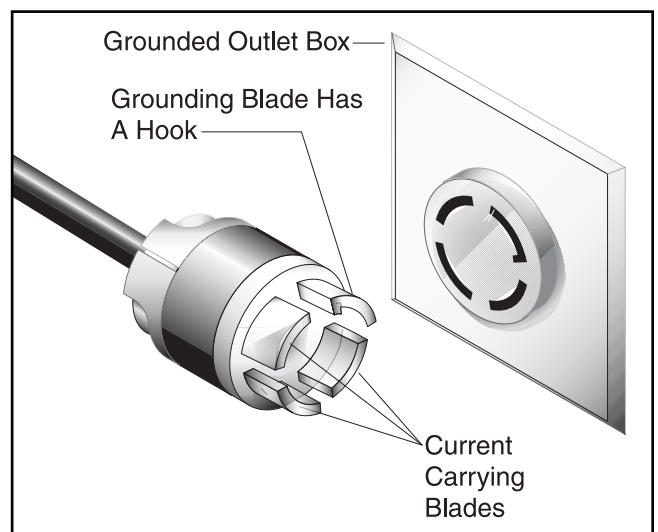



Figure 2. NEMA-style L15-20 plug and outlet.



Grounding

In the event of an electrical short, grounding provides electric current a path of least resistance to reduce the risk of electrical shock. This tool is equipped with an electric cord having an equipment-grounding conductor which must be properly connected to a grounding plug. The plug must be plugged into a matching outlet that is properly installed and grounded in accordance with all local codes and ordinances.

Improper connections of the electrical-grounding conductor can result in the risk of electric shock. The conductor with green or green and yellow striped insulation is the electrical-grounding conductor. If repair or replacement of the electric cord or plug is necessary, do not connect the equipment grounding conductor to a live terminal.

	<p>! WARNING</p> <p>This equipment must be grounded. Verify that any existing electrical outlet and circuit you intend to plug into is actually grounded. Under no circumstances should the grounding pin from any three-pronged plug be removed. Serious injury may occur.</p>
--	--



Extension Cords

We do not recommend the use of extension cords with 220V equipment. It is much better to arrange the placement of your equipment and the installed wiring to eliminate the need for extension cords. Should it be necessary to use an extension, make sure the cord is rated Hard Service (grade S) or better. Refer to the chart in *Section 1: Safety Instructions* to determine the minimum gauge for the extension cord when using either 110V or 220V. The extension cord must also contain a ground wire and plug pin. Always repair or replace extension cords when they become worn or damaged.



<p>! CAUTION</p> <p>We have covered some basic electrical requirements for the safe operation of your machine. These requirements are not necessarily comprehensive. You must be sure that your particular electrical configuration complies with local and state codes. Ensure compliance by checking with your local municipality or a licensed electrician.</p>

SECTION 3: INTRODUCTION

Commentary

We are proud to offer the Grizzly Model G9984/G9985 Oscillating Belt Edge Sander. The Model G9984/G9985 is part of a growing Grizzly family of fine woodworking machinery. When used according to the guidelines set forth in this manual, you can expect years of trouble-free, enjoyable operation and proof of Grizzly's commitment to customer satisfaction.

The Model G9984 and G9985 are identical machines except for the phase operation of the motors. The Model G9984 is equipped with a 3 H.P., 220V single-phase motor and the Model G9985 is equipped with a 3 H.P., 220V three-phase motor.

Additional features of the Model G9984/G9985 include a 9" x 138½" sanding belt capacity, a 4150 F.P.M. belt speed, 8" of table height adjustment, ¼" oscillation stroke, a 4" dust port and side table for sanding curved pieces.

A number of sanding belts and accessories for the Model G9984/G9985 are available through the Grizzly catalog.

We are also pleased to provide this manual with the Model G9984/G9985. It was written to guide you through assembly, review safety considerations, and cover general operating procedures. It represents our effort to produce the best documentation possible. If you have any comments regarding this manual, please write to us at the address below:

Grizzly Industrial, Inc.
% Technical Documentation
P.O. Box 2069
Bellingham, WA 98227-2069

Most importantly, we stand behind our machines. If you have any service questions or parts requests, please call or write us at the location listed below:

Grizzly Industrial, Inc.
1203 Lycoming Mall Circle
Muncy, PA 17756
Phone: (570) 546-9663
Fax: (800) 438-5901
E-Mail: techsupport@grizzly.com
Web Site: <http://www.grizzly.com>

The specifications, drawings, and photographs illustrated in this manual represent the Model G9984/G9985 as supplied when the manual was prepared. However, owing to Grizzly's policy of continuous improvement, changes may be made at any time with no obligation on the part of Grizzly. Whenever possible, though, we send manual updates to all owners of a particular tool or machine. Should you receive one, we urge you to insert the new information with the old and keep it for reference.

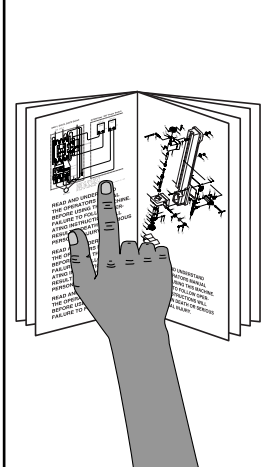
	<p>!WARNING</p> <p>Read the manual before assembly and operation. Become familiar with the machine and its operation before beginning any work. Serious personal injury may result if safety or operational information is not understood or followed.</p>
--	--



Unpacking

The Model G9984/G9985 is shipped from the manufacturer in a carefully packed carton. If you discover the machine is damaged after you have signed for delivery, immediately call Customer Service for advice.

The Model G9984/G9985 has two lifting rings located on the top of the access door as shown in **Figure 3**.

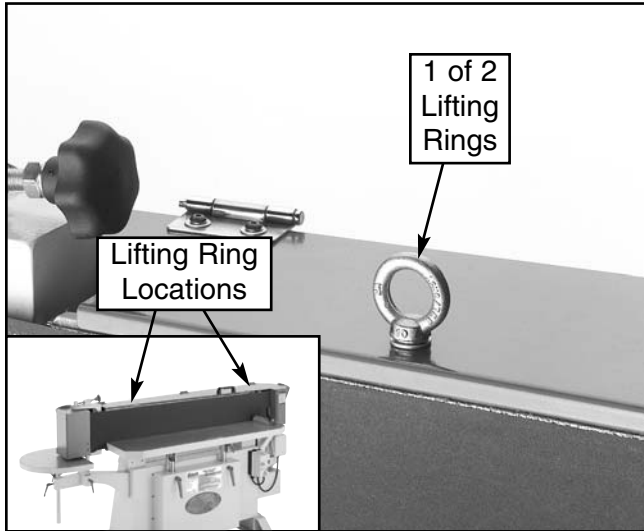
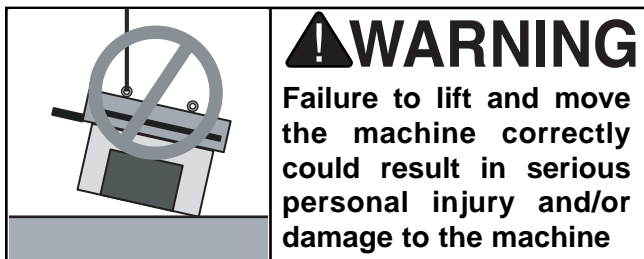

Figure 3. Lifting ring.

When using a lifting apparatus to move the machine, always lift from both of these designated rings. Lifting at any other location, or from only one ring at a time, could cause the machine to become unbalanced and tip over. A hydraulic pallet jack or fork lift can also be used. Damage from improper moving methods may void the warranty.



When the machine is in its final location, replace the lifting rings with the star knobs as shown in **Figure 4**. Be sure to place the 10mm flat washers and 10mm lock washers on the star knobs threaded post before installing. These washers help the star knobs remain secure and protect the finish of the machine.

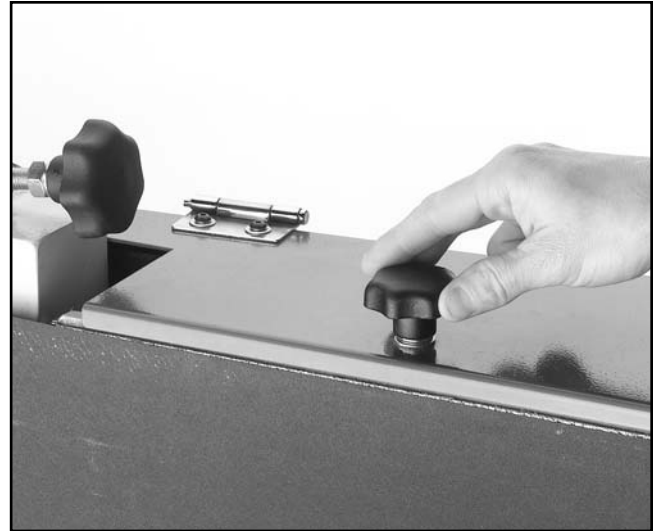
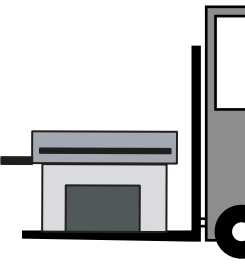



Figure 4. Star knob installation.

Keep the lifting rings in a safe location where they will not become lost. These rings will need to be re-installed if the machine is ever to be lifted and moved in the future.



⚠️ WARNING

The Model G9984/G9985 is a heavy machine with a 792 lb. shipping weight. **DO NOT** over-exert yourself while unpacking or moving your machine – you will need assistance and power equipment. Serious personal injury may occur if safe moving methods are not followed.



⚠️ WARNING

Make sure floor structure is capable of supporting the combined weight of the machine parts and people.



⚠️ CAUTION

Some metal parts may have sharp edges on them after they are formed. Please examine the edges of all metal parts before handling them. Failure to do so could result in injury.



Piece Inventory

After all the parts have been removed from the carton, you should have:

- (2) Base Support
- (2) Star Knob M10-1.5 x 15
- (4) Lock Washer 10mm
- (6) Flat Washer 10mm
- (4) Hex Bolt M10-1.5 x 30
- (4) Rubber Foot ½"-12 x 1
- (1) Sanding Belt 9" x 138½"



Figure 5. Parts layout.

In the event that any nonproprietary parts are missing (e.g. a nut or a washer), we would be glad to replace them, or for the sake of expediency, replacements can be obtained at your local hardware store.



Hardware Recognition Chart

Use this chart to match up hardware pieces during the assembly process!

MEASURE BOLT DIAMETER BY PLACING INSIDE CIRCLE

- #10
- 1/4"
- 5/16"
- 3/8"
- 7/16"
- 1/2"
- 5/8"
- 4mm
- 6mm
- 8mm
- 10mm
- 12mm
- 16mm

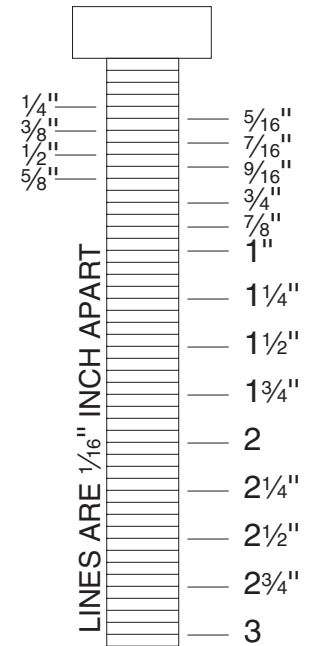
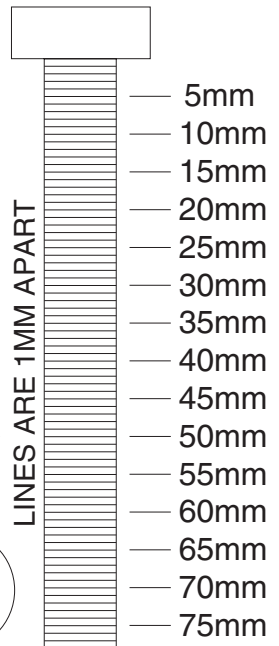
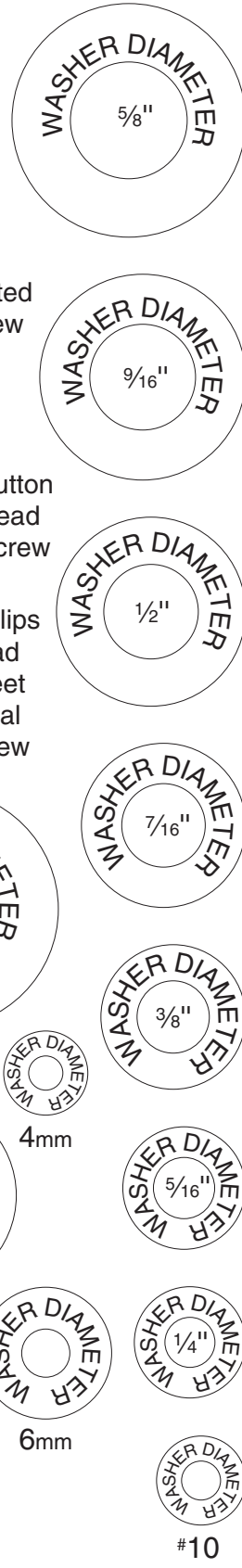
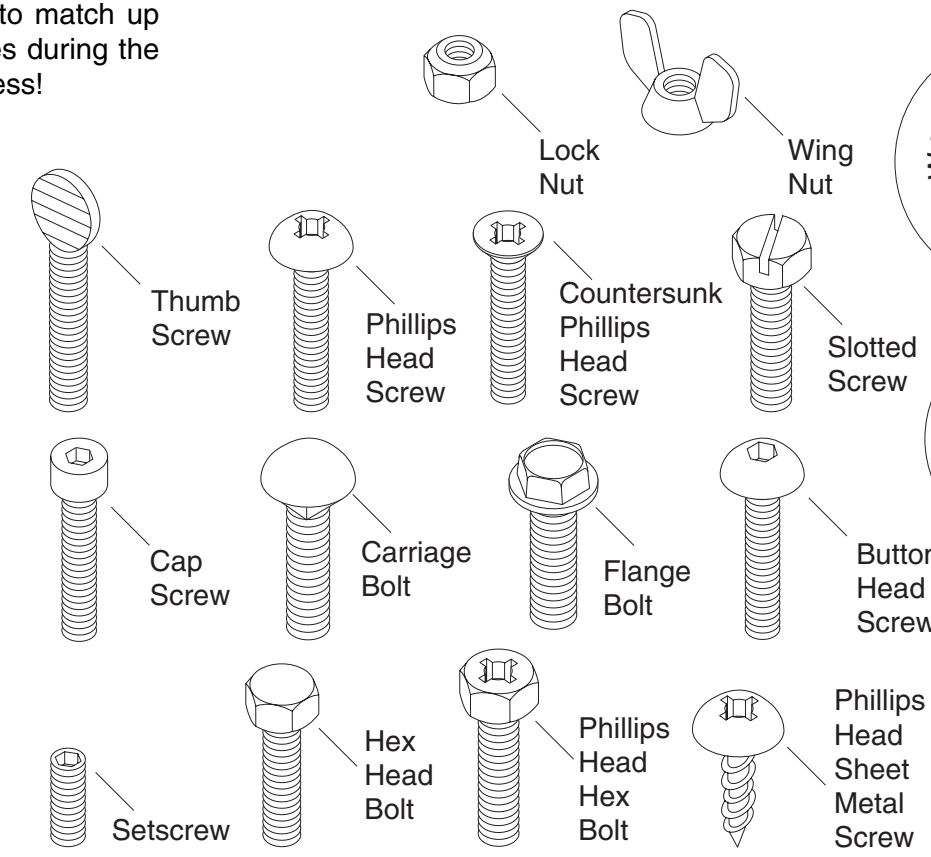

WASHERS ARE MEASURED BY THE INSIDE DIAMETER

Clean Up

The unpainted surfaces are coated with a waxy oil to protect them from corrosion during shipment. Remove this protective coating with a solvent cleaner or citrus-based degreaser such as Grizzly's G7895 Degreaser. Avoid chlorine-based solvents as they may damage painted surfaces should they come in contact. Always follow the usage instructions on the product you choose for clean up.

	<p>⚠️ WARNING Do not use gasoline or other petroleum-based solvents. They have low flash points which make them extremely flammable. A risk of explosion and burning exists if these products are used. Serious personal injury may occur if this warning is ignored.</p>
--	--

	<p>⚠️ WARNING Do not smoke while using solvents. A risk of explosion or fire exists and may result in serious personal injury.</p>
---	---

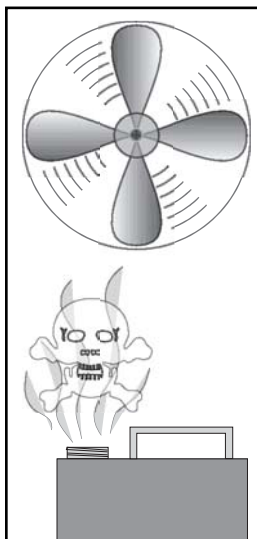
	<p>⚠️ CAUTION Many of the solvents commonly used to clean machinery can be toxic when inhaled or ingested. Always work in well-ventilated areas far from potential ignition sources when dealing with solvents. Use care when disposing of waste rags and towels to be sure they do not create fire or environmental hazards.</p>
---	--



Site Considerations

FLOOR LOAD

Your Model G9984/G9985 represents a large weight load in a medium footprint. Most commercial or home shop floors should be sufficient to carry the weight of the Model G9984/G9985. If you question the strength of your floor, you can opt to reinforce it. Ensure that the stand or bench you use with the Model G9984/G9985 is capable of supporting the machine.

WORKING CLEARANCES

Working clearances can be thought of as the distances between machines and obstacles that allow safe operation of every machine without limitation. Consider existing and anticipated machine needs, size of material to be processed through each machine, and space for auxiliary stands and/or work tables. Also, consider the relative position of each machine to one another for efficient material handling. Be sure to allow yourself sufficient room to safely run your machines in any foreseeable operation and keep dust collection hoses off the floor and out of the way.

LIGHTING AND OUTLETS

Lighting should be bright enough to eliminate shadows and prevent eye strain. Electrical circuits should be dedicated or large enough to handle combined motor amp loads. Outlets should be located near each machine so power or extension cords are not obstructing high-traffic areas. Be sure to observe local electrical codes for proper installation of new lighting, outlets, or circuits.

	<p>⚠️ CAUTION Make your shop "child safe." Ensure that your workplace is inaccessible to youngsters by closing and locking all entrances when you are away. Never allow visitors in your shop when assembling, adjusting or operating equipment.</p>
--	---



SECTION 4: ASSEMBLY

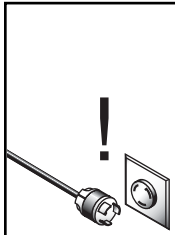

⚠️ WARNING

Disconnect power to the machine when performing any assembly procedures on the Model G9984/G9985. Failure to do this may result in serious personal injury.

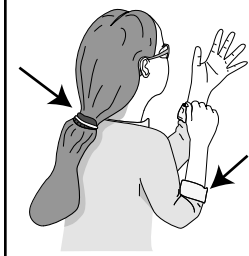

⚠️ WARNING

Keep loose clothing rolled up and out of the way of machinery and keep hair pulled back.



⚠️ WARNING

Wear safety glasses during the entire assembly process. Failure to comply may result in serious personal injury.



⚠️ CAUTION

Some metal parts may have sharp edges on them after they are formed. Please examine the edges of all metal parts before handling them. Failure to do so could result in injury.

Beginning Assembly

Most of your Model G9984/G9985 has been assembled at the factory, but some parts must be assembled or installed after delivery.

TOOLS REQUIRED: You will need a small adjustable wrench, a flat and Phillips head screwdriver, and a machinist's square.



Rubber Feet

Four rubber feet are furnished to help absorb machine vibration, to even out imperfections in the floor, and to protect the machine from general stress. To install the rubber feet:

1. Thread the end of the rubber feet into the threaded holes on the underside of the base supports as shown in **Figure 6**.
2. Do not overtighten the feet. Cast iron threads are softer than the steel threads on the feet. Overtightening can cause the cast iron threads to become stripped.

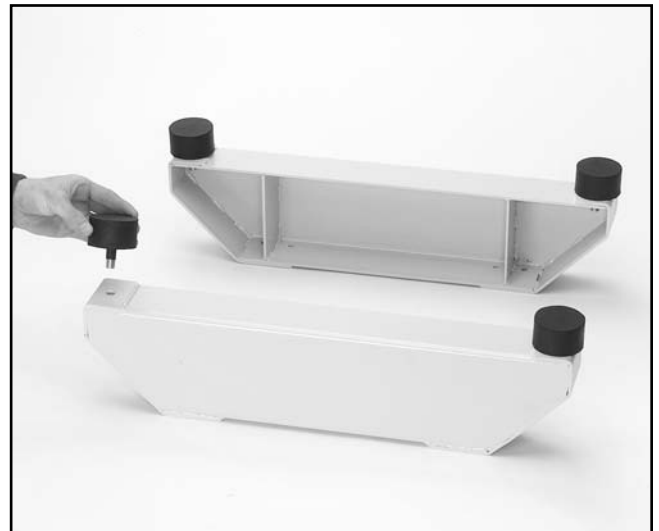

Figure 6. Attaching rubber feet.



Base Supports

Attaching the base supports to the main base:

1. Slide the base supports under the main machine base.
2. Using (4) M10-1.5 x 30 hex bolts, (4) 10mm flat washers, and (4) 10mm lock washers, secure the main machine base to the base supports as shown in **Figure 7**. Be sure the lock washer is between the hex bolt head and the flat washer when installing.

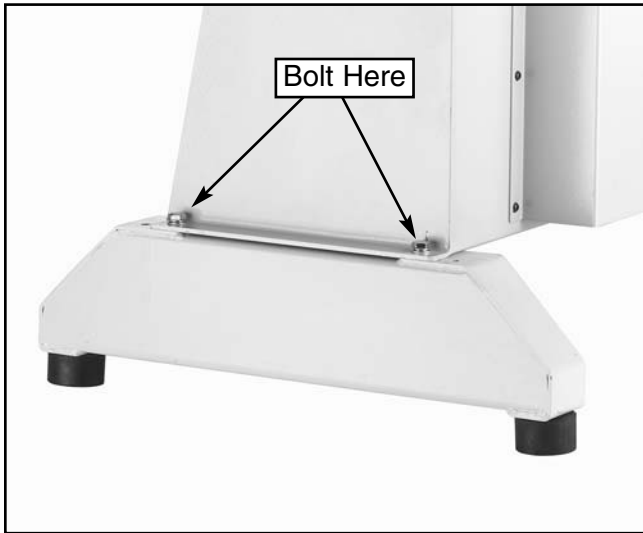
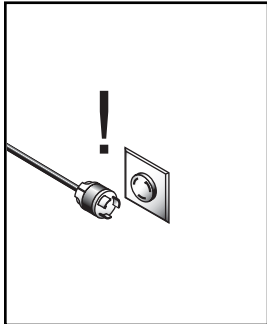

Figure 7. Attaching base supports to main base.



SECTION 5: ADJUSTMENTS



⚠ WARNING
Disconnect power to the machine when performing any adjustments on the Model G9984/G9985. Failure to do this may result in serious personal injury.



⚠ WARNING
Keep loose clothing rolled up and out of the way of machinery and keep hair pulled back.



⚠ WARNING
Wear safety glasses during the entire adjustment process. Failure to comply may result in serious personal injury.

Power Switch

The Model G9984/G9985 must be turned ON to visually check the results of certain adjustments made to the sander; however, actual adjustments should never be performed while the machine is plugged in.



Figure 9. Magnetic power switch.



Dust Collection

The Model G9984/G9985 has (2) 4" dust hoods. One is positioned for use with the side table. The second dust hood is for use with the main table. The side table dust hood is adjustable to allow optimum positioning for various sanding operations. To adjust the side table dust hood:

1. Loosen the lock handle shown in **Figure 8**.
2. Rotate the dust hood until the desired position is achieved.
3. Tighten the lock handle loosened in **Step 1**.
4. Hook up a 4" dust collection hose to the dust hood and secure with a hose clamp.

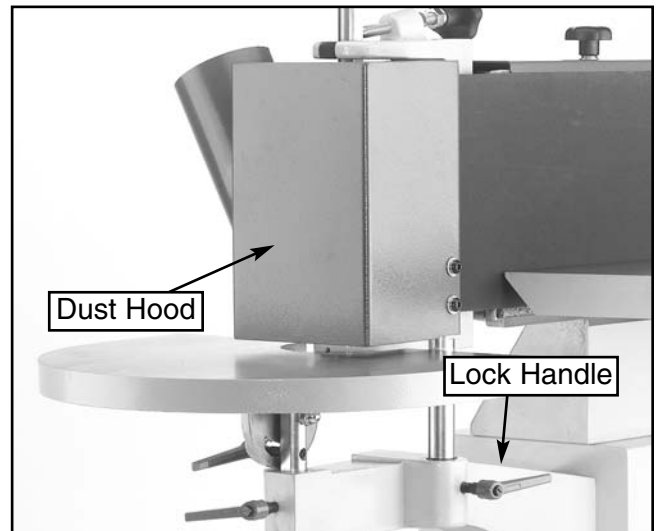
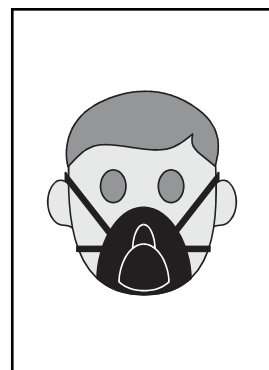

Figure 8. Dust hood lock handle.



⚠ CAUTION
Always wear a dust mask when using the Model G9984/G9985. Using this machine produces sawdust which may cause allergic reactions or respiratory problems.



Sanding Belt Rotation

It is necessary to check the sanding belt rotation before performing any sanding operations. The sanding belt should rotate in the same direction as the sticker located on the top of the top of the machine. To check the sanding belt rotation:

!WARNING

It is necessary to plug the machine into a power source to visually check the sanding belt rotation. Do not attempt to perform any adjustments to the sanding belt while the machine is connected to a power source. Failure to unplug before adjusting the sanding belt could result in serious personal injury.

1. Press the ON switch and then the OFF switch immediately after. The sander should run just long enough to observe the direction of the sanding belt.
2. The sanding belt should rotate in the same direction as the arrow sticker in **Figure 10**.
3. If the sanding belt does not rotate in the correct direction, contact our Service Department immediately.

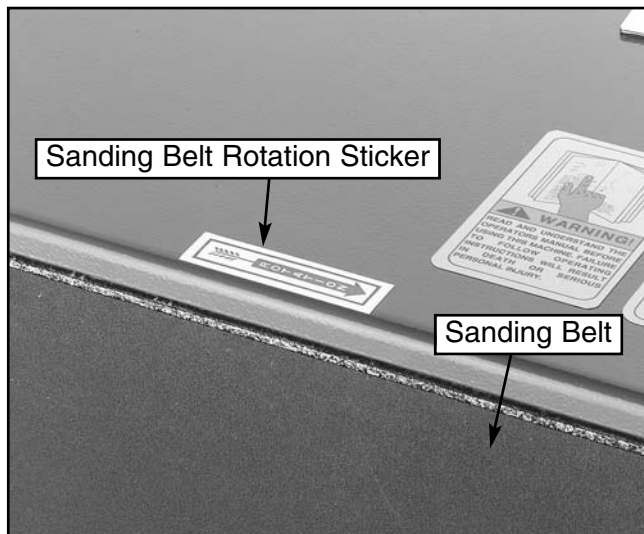

Figure 10. Sanding belt rotation arrow.



Sanding Belt Replacement

To replace the sanding belt:

1. **Disconnect the machine from the power source!**
2. Lift the access door to allow easy access to the sanding belt and the tensioning lever.
3. Shift the tension lever to the left to loosen the sanding belt as shown in **Figure 11**.
4. Remove the old sanding belt and replace it with a new one.
5. Make sure the directional arrow on the inside of the sanding belt is pointing in the same direction as the directional arrow on the machine.
6. Shift the tension lever to the right to tension the new sanding belt.
7. Adjust the sanding belt tracking (see next section).



Figure 11. Sanding belt tension lever.



Sanding Belt Tracking

After the sanding belt has been removed or replaced, it is necessary to adjust the sanding belt tracking. To adjust the sanding belt tracking:

!WARNING

It is necessary to plug the machine into a power source to visually check the sanding belt tracking. **DO NOT** attempt to perform any adjustments to the sanding belt while the machine is connected to a power source. Failure to unplug before adjusting the sanding belt could result in serious personal injury.

1. Press the ON switch and then the OFF switch immediately after. The sander should run just long enough to observe the track the sanding belt makes across the rollers.
2. If the sanding belt does not track on a centered path across the rollers, adjustment is necessary.
3. **Disconnect the machine from the power source!**
4. Loosen the check nut shown in **Figure 12**.

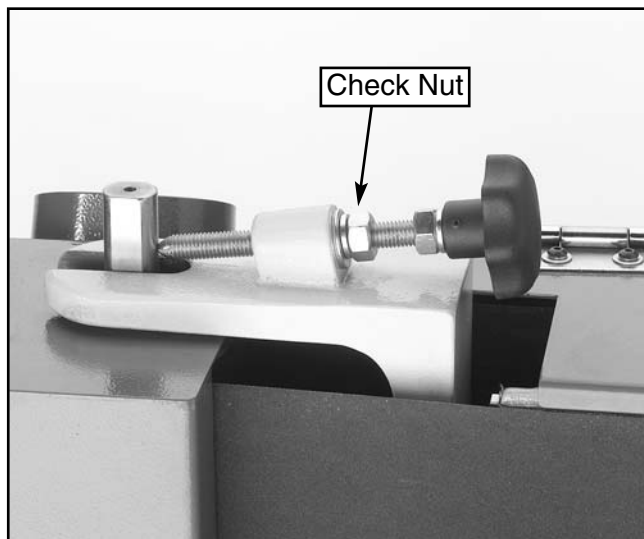

Figure 12. Belt tracking knob.

5. Turn the adjustment knob counter-clockwise to adjust the tracking upward. Turn the adjustment knob clockwise to adjust the tracking downward.
6. Once sanding belt is consistently tracking across the center of the rollers, tighten down the check nut that was loosened in **Step 4**.



Main Table Height

The main table is adjustable to accommodate a wide range of workpieces and sanding operations. Because the main table is designed with a special balance mount, it is easily adjusted up and down. To adjust the main table:

1. Loosen the lock handles on the front of the sander.
2. Move the main table to the desired height as shown in **Figure 13**.
3. While holding the main table at the desired height, tighten the lock handles loosened in **Step 1**.



Figure 13. Adjusting main table height.



Main Table Angle

The main table position can be adjusted from 0° - 45°. To adjust the angle position of the main table:

1. Loosen the lock handles underneath each end of the main table as shown in **Figure 14**.
2. Tilt the table into the desired position. The scale on the side of the bracket can help you find specific angles. While holding the table in the desired position, tighten each of the locking handles loosened in **Step 1**.
3. Changing the table angle may reduce the clearance between the inside edge of the table and the sanding belt surface. If there is less than $\frac{1}{16}$ " clearance, loosen the fixing bolts located on the underside of the table mounting bracket as shown in **Figure 14**. Pull the table and mounting bracket away from the sanding belt so there is at least $\frac{1}{16}$ " clearance between the inside edge of the table and the sanding belt surface.
4. While holding the main table in the desired position, tighten the fixing bolts loosened in **Step 3**.
5. Recheck the clearance between the main table and the sanding belt. Repeat **Steps 3** and **4** if necessary.

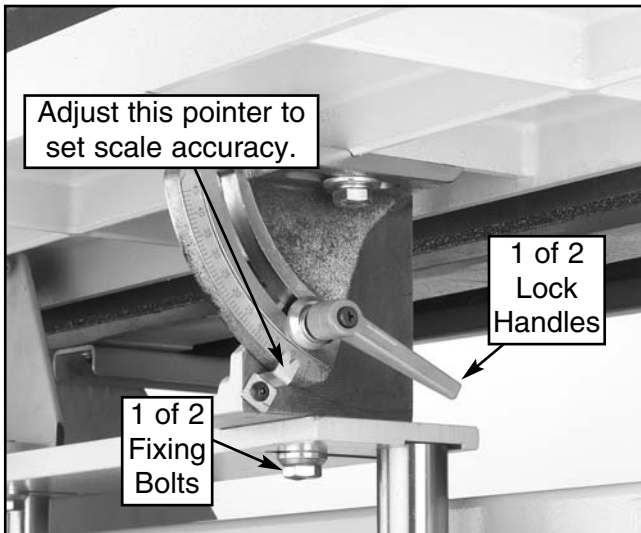

Figure 14. Main table angle adjustment lever.

6. We recommend using a square to adjust and/or verify the main table angle scale accuracy as shown in **Figure 15**.

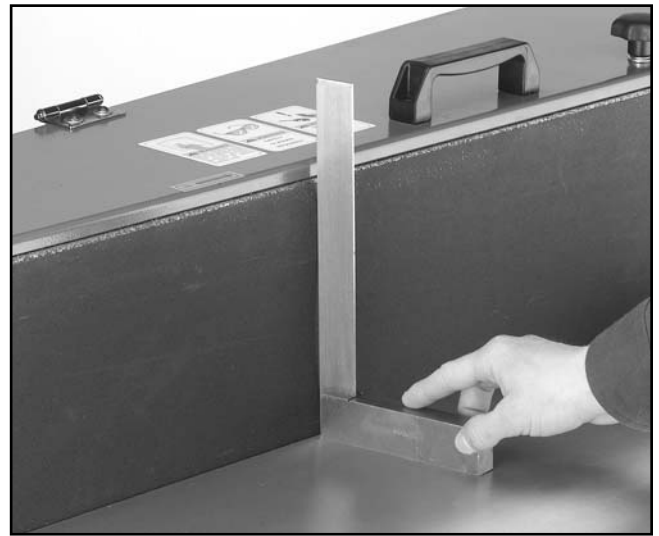

Figure 15. Setting main table to 90°.



Miter Gauge

The main table has a stationary miter gauge that is used to hold the workpiece at various angles against the sanding belt. To adjust the miter gauge:

1. Loosen the lock handle shown in **Figure 16**.
2. Rotate the miter gauge to the desired angle.
3. While holding the miter gauge in the desired position, tighten the lock handle loosened in **Step 1**.
4. We recommend using a square to adjust and/or verify the miter gauge scale as shown in **Figure 17**.

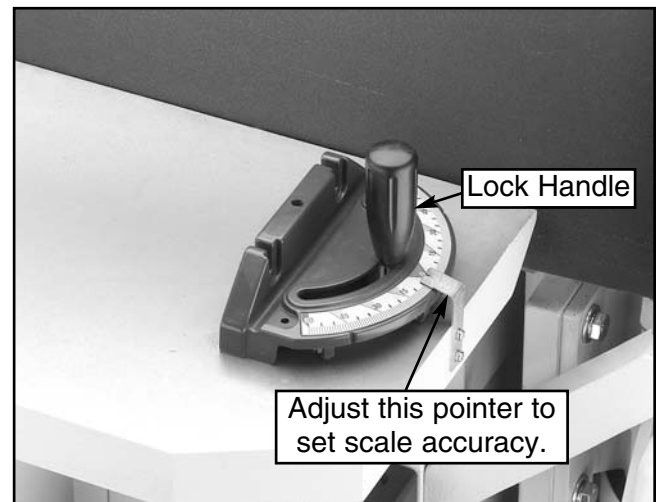

Figure 16. Main table miter gauge.

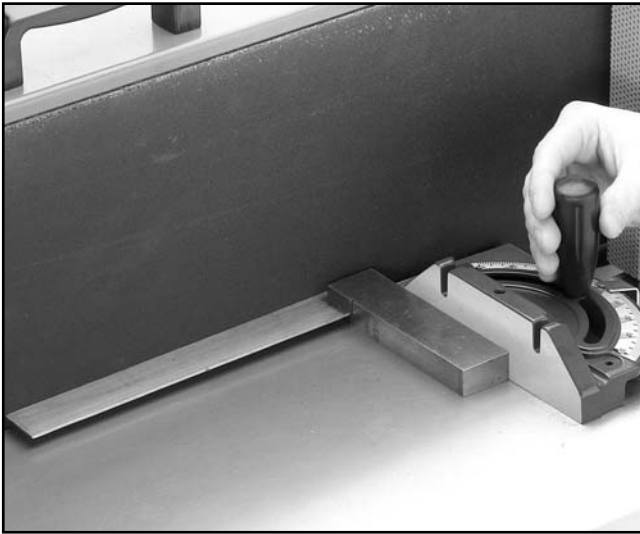

Figure 17. Setting miter gauge to 90°.



Side Table Height

The side table can be adjusted to accommodate a wide range of workpieces. To adjust the side table:

1. Loosen the lock handle shown in **Figure 18**.
2. Move the side table to the desired height.
3. While holding the side table at the desired height, tighten the lock handle loosened in **Step 1**.



Figure 18. Lock handle for side table height.



Side Table Angle

The side table can be adjusted to accommodate sanding at various angles. To adjust the angle position of the side table:

1. Loosen the lock handle underneath the side table shown in **Figure 19**.
2. Move the side table to the desired position.
3. While holding the side table in the desired position, tighten the lock handle loosened in **Step 1**.

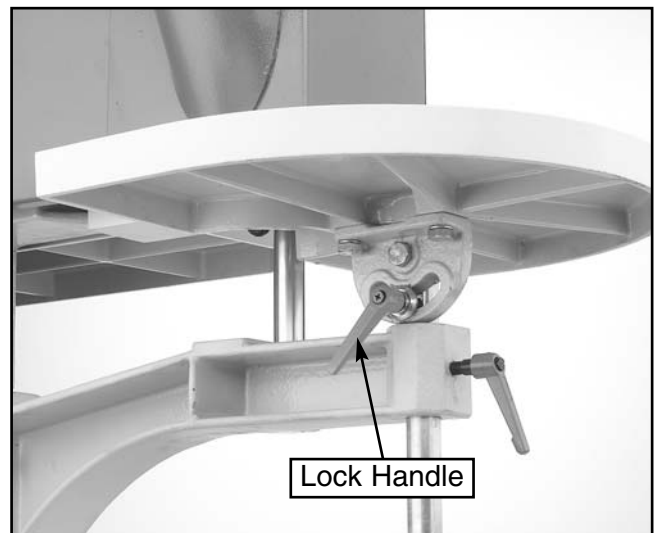
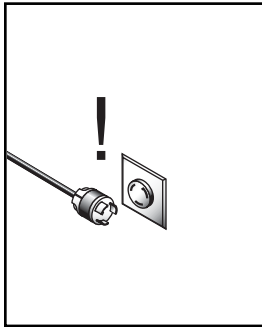

Figure 19. Lock handle for side table angle.



SECTION 6: OPERATIONS



! WARNING
Disconnect power to the machine when performing any maintenance, assembly or adjustments. Failure to do this may result in serious personal injury.



! WARNING
Keep loose clothing rolled up and out of the way of machinery and keep hair pulled back.



! WARNING
Wear safety glasses during the entire operation process. Failure to comply may result in serious personal injury.

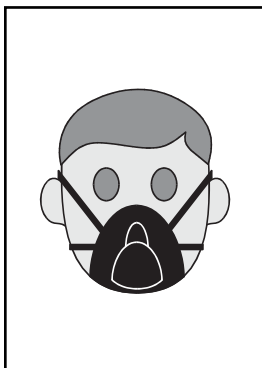

! CAUTION
Always wear a dust mask when operating the Model G9984/G9985. Using this machine produces sawdust which may cause allergic reactions or respiratory problems.

Test Run

Once assembly is complete and adjustments are done to your satisfaction, you are ready to test run the machine.

Turn on the power supply at the main panel. Press the START button. Make sure that your finger is poised on the switch, just in case there is a problem. The machine should run smoothly, with little or no vibration or rubbing noises. Strange or unnatural noises should be investigated and corrected before operating the machine further.

If you cannot easily locate the source of an unusual noise or vibration, contact our Service Department for help.



Sanding Belts

There are many types of sanding belts to choose from. We recommend Aluminum Oxide for general workshop environments. Below is a chart that groups abrasives into different classes, and shows which grits fall into each class.

Grit	Type
24-36	Very Coarse
40-60	Coarse
80-100	Medium
120-180	Fine
220-360	Very Fine

The general rule of thumb is to sand a workpiece with progressively higher grit numbers, with no one grit increase of more than 100.



SECTION 7: MAINTENANCE

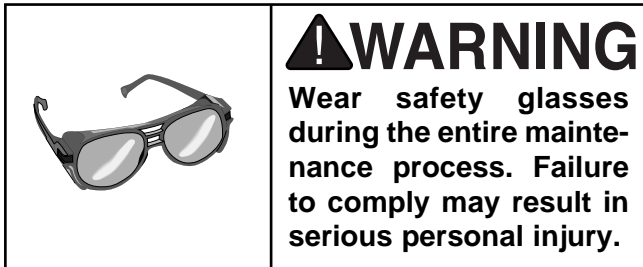
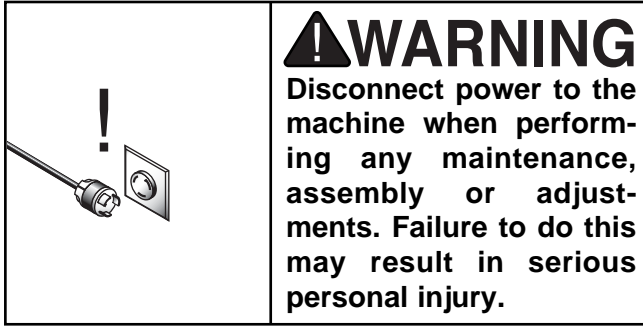

General

Regular periodic maintenance of your Model G9984/G9985 will ensure its optimum performance. Make a habit of inspecting your machine each time you use it. Check for the following conditions and repair or replace when necessary:

1. Loose mounting bolts.
2. Worn switch.
3. Worn or damaged cords and plugs.
4. Damaged or worn sanding belt.
5. Any other condition that could hamper the safe operation of this machine.



Tables

Tables can be kept rust-free with regular applications of products like Boeshield® T-9. For long term storage you may want to consider products like Kleen Bore's Rust Guardit™.



Lubrication

There are (2) grease fittings shown in **Figure 20**. Grease these points after approximately 50 hours of use.

All other bearings are sealed and permanently lubricated, simply leave them alone until they need to be replaced. Do not lubricate them.

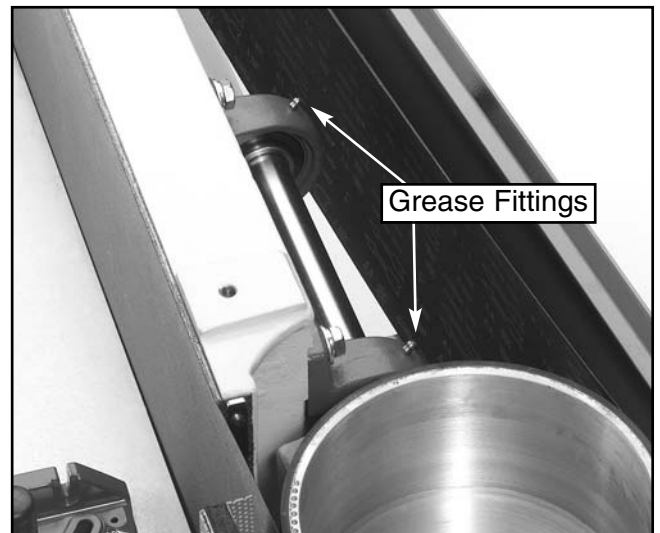

Figure 20. Oscillation grease fittings.



SECTION 8: CLOSURE

The following pages contain general machine data, parts diagrams/lists, a troubleshooting guide and Warranty/Return information for your Model G9984/G9985.

If you need parts or help in assembling your machine, or if you need operational information, we encourage you to call our Service Department. Our trained service technicians will be glad to help you.

If you have comments dealing specifically with this manual, please write to our Bellingham, Washington location using the address in *Section 3: Introduction*.

We have included some important safety measures that are essential to this machine's operation. While most safety measures are generally universal, each workshop is different and safety rules should be considered as they apply to your specific situation.

We recommend you keep a copy of our current catalog for complete information regarding warranty and return policy. If you need additional technical information relating to this machine, or if you need general assistance or replacement parts, please contact the Service Department listed in *Section 3: Introduction*.

Additional information sources are necessary to realize the full potential of this machine. Trade journals, woodworking magazines, and your local library are good places to start.

<p>⚠️ WARNING</p> <p>Operating this equipment creates the potential for flying debris to cause eye injury. Always wear safety glasses or goggles when operating equipment. Everyday glasses or reading glasses only have impact resistant lenses, they are not safety glasses. Be certain the safety glasses you wear meet the appropriate standards of the American National Standards Institute (ANSI).</p>		
		

<p>⚠️ WARNING</p> <p>The Model G9984/G9985 was specifically designed for sanding operations. DO NOT MODIFY AND/OR USE THIS MACHINE FOR ANY OTHER PURPOSE. Modifications or improper use of this tool will void the warranty. If you are confused about any aspect of this machine, DO NOT use it until all your questions have been answered or serious personal injury may occur.</p>

<p>⚠️ WARNING</p> <p>Like all power tools, there is danger associated with the Model G9984/G9985. Accidents are frequently caused by lack of familiarity or failure to pay attention. Use this tool with respect and caution to lessen the possibility of operator injury. If normal safety precautions are overlooked or ignored, serious personal injury may occur.</p>
--





⚠ DANGER
Disconnect power from machine before performing any electrical service. Failure to do this will result in a shock hazard leading to injury or death.

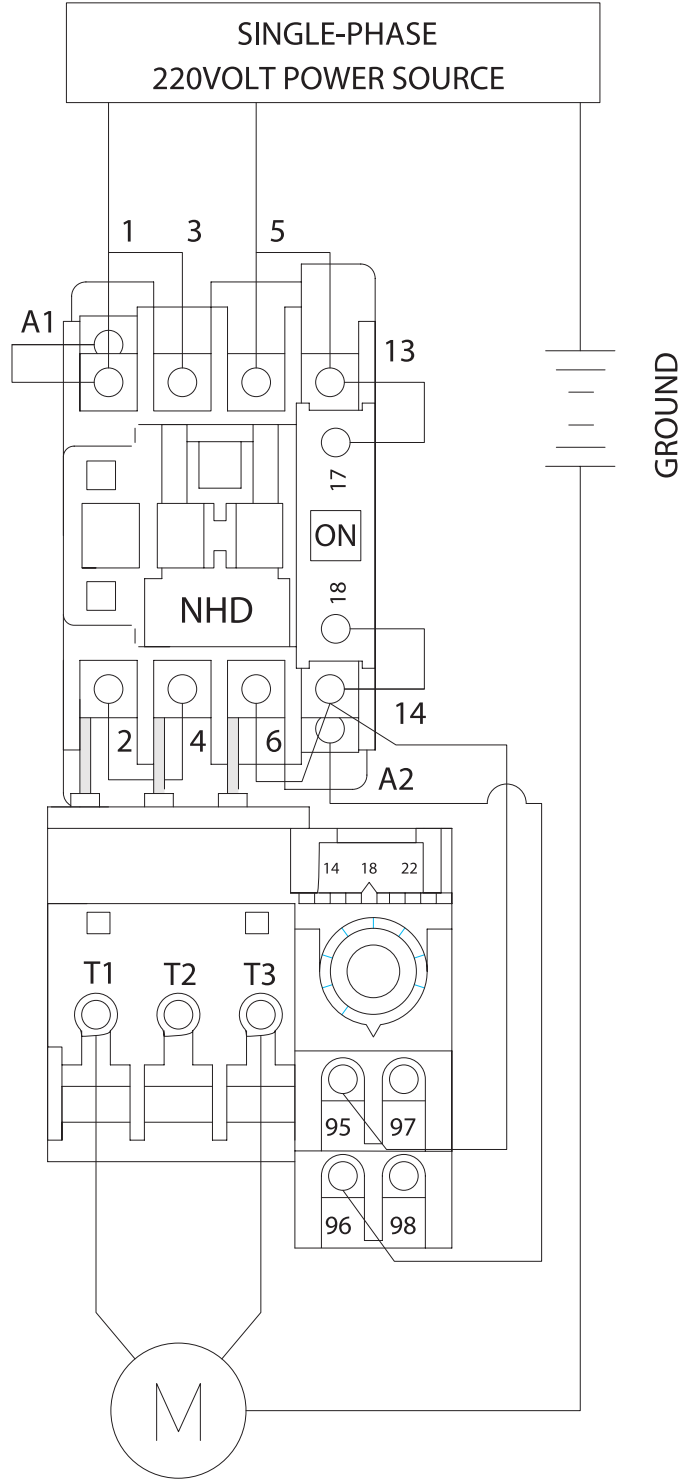



⚠ DANGER
 Disconnect power from machine before performing any electrical service. Failure to do this will result in a shock hazard leading to injury or death.

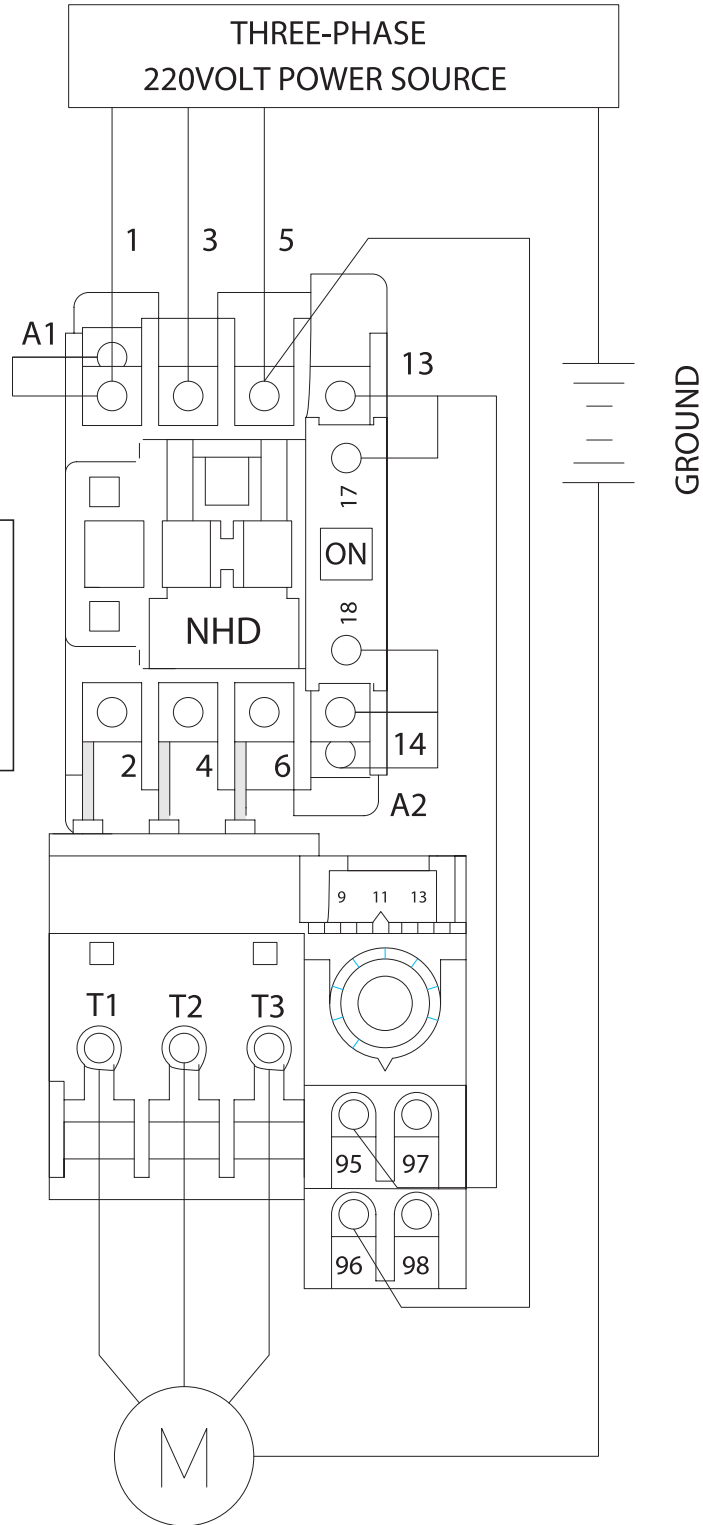



MACHINE DATA SHEET

Customer Service #: (570) 546-9663 • To Order Call: (800) 523-4777 • Fax #: (800) 438-5901

GRIZZLY MODEL G9984 OSCILLATING EDGE SANDER

Design Type..... Floor Model

Overall Dimensions and Specifications:

Table Size.....47³/₄" x 11³/₄"
 Overall Height (With Handle Up)45¹/₂"
 Table Height (from bottom of base)33" to 41"
 Length82"
 Width24"
 Side Sanding Table Dimensions18" x 13"
 Sanding Table Travel7"
 Platen SizeGraphite Coated - 9¹/₂" x 47¹/₂"
 Belt Size9" x 138¹/₂"
 Belt Speed.....4120 F.P.M.
 Table Tilt0° to 45°
 Shipping Weight.....792 lbs.
 Net Weight.....682lbs.
 Crate Size86⁵/₈" L x 28¹/₄" W x 45¹/₄" H
 Footprint.....42" x 24¹/₂"

Construction:

BaseSheet Steel
 Table.....Aluminum
 Idler RollerRubber, 4"
 Drive RollerRubber, 9"

Motor:

TypeTEFC Capacitor Start Induction
 Horsepower.....3 H.P.
 Phase - Voltage.....Single Phase - 220V
 Amps.....16
 Cycle and R.P.M.60 Hertz / 1725 R.P.M.
 Switch.....Magnetic w/ Thermal Protection
 Power TransferDirect Drive
 BearingsShielded & Lubricated Ball Bearings

Features:

.....Sanding Belt Oscillates 1/4"
4" Dust Port
Miter Work Stop
Quick Belt Release Lever
Belt Tracking and Tension Adjustment
8" of Table Height Adjustment
Graphite Coated Platten

Specifications, while deemed accurate, are not guaranteed.



MACHINE DATA SHEET

Customer Service #: (570) 546-9663 • To Order Call: (800) 523-4777 • Fax #: (800) 438-5901

GRIZZLY MODEL G9985 OSCILLATING EDGE SANDER

Design Type..... Floor Model

Overall Dimensions and Specifications:

Table Size.....47³/₄" x 11³/₄"
 Overall Height (With Handle Up)45¹/₂"
 Table Height (from bottom of base)33"-41"
 Length82"
 Width24"
 Side Sanding Table Dimensions18" x 13"
 Sanding Table Travel7"
 Platen SizeGraphite Coated - 9¹/₂" x 47¹/₂"
 Belt Size9" x 138¹/₂"
 Belt Speed.....4120 F.P.M.
 Table Tilt0° to 45°
 Shipping Weight.....792 lbs.
 Net Weight.....682lbs.
 Crate Size86⁵/₈" L x 28¹/₄" W x 45¹/₄" H
 Footprint.....42" x 24¹/₂"

Construction:

BaseSheet Steel
 Table.....Aluminum
 Idler RollerRubber, 4"
 Drive RollerRubber, 9"

Motor:

TypeInduction
 Horsepower.....3 H.P.
 Phase - Voltage.....Three Phase - 220V
 Amps9A
 Cycle and R.P.M.60 Hertz / 1725 R.P.M.
 Switch.....Magnetic w/ Thermal Protection
 Power TransferDirect Drive
 BearingsShielded & Lubricated Ball Bearings

Features:

.....Sanding Belt Oscillates 1/4"
4" Dust Port
Miter Work Stop
Quick Belt Release Lever
Belt Tracking and Tension Adjustment
8" of Table Height Adjustment
Graphite Coated Platten

Specifications, while deemed accurate, are not guaranteed.

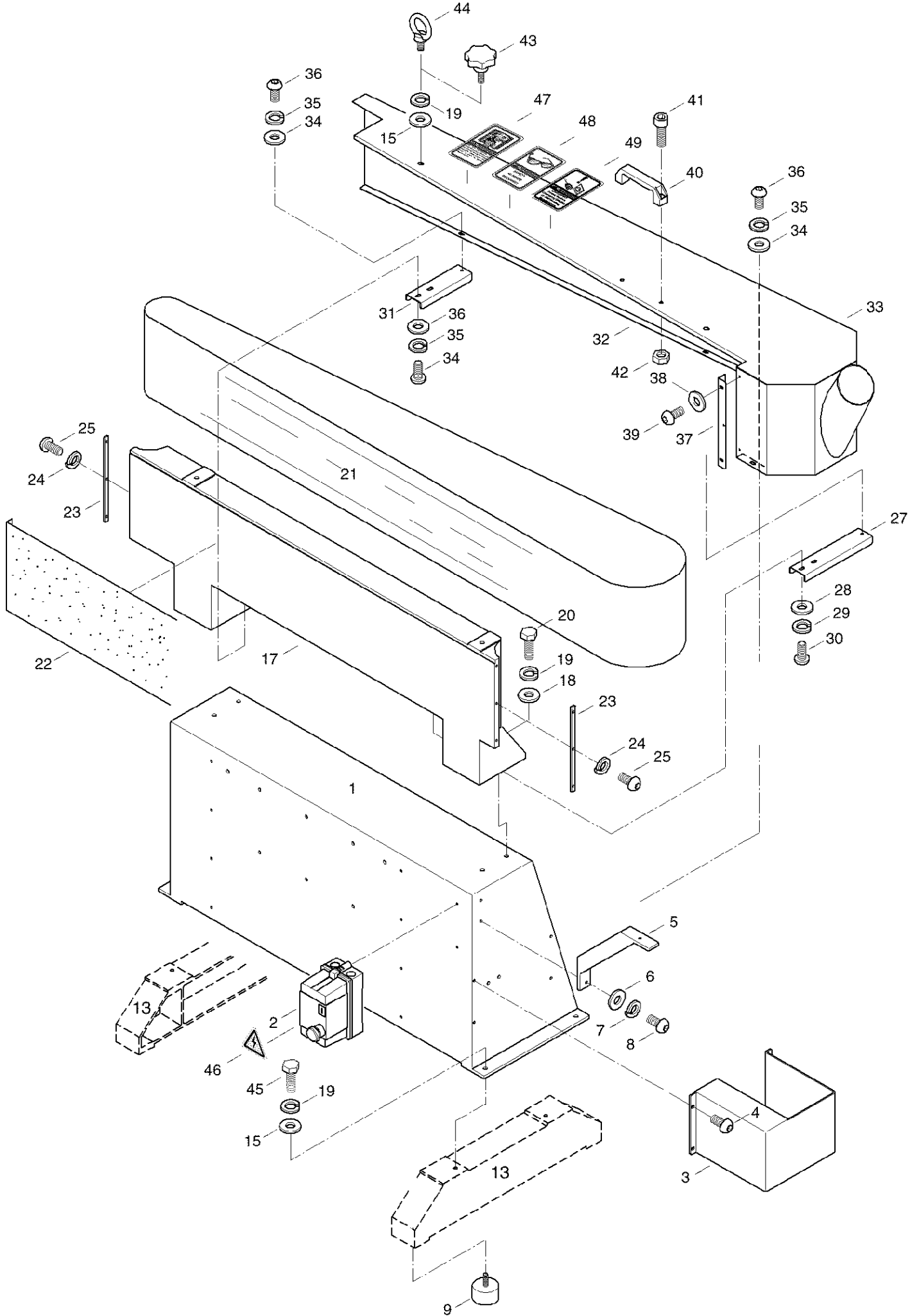

REF	PART #	DESCRIPTION
01	P9984001	MACHINE BASE
02	G4573	MAGNETIC SWITCH-G9984
02	G4673	MAGNETIC SWITCH-G9985
03	P9984003	COVER
04	PS14M	PHLP HD SCR M6-1.0 X 12
05	P9984005	BRACKET
06	PW06	FLAT WASHER ¼"
07	PLW02	LOCK WASHER ¼"
08	PS26M	PHLP HD SCR M6-1.0 X 20
09	P9984009	RUBBER FOOT
13	P9984013	BASE SUPPORT
15	PW04M	FLAT WASHER 10mm
17	P9984017	SUPPORT
18	PW02	FLAT WASHER ⅜"
19	PLW06M	LOCK WASHER 10mm
20	PB31M	HEX BOLT M10-1.5 x 40
21	P9984021	SANDING BELT 9" x 138½"
22	P9984022	PLATTEN 7/16" X 1389/16"
23	P9984023	PLATE
24	PLW01M	LOCK WASHER 5mm
25	PS40M	PHLP HD SCR M5-0.8 X 16
27	P9984027	BRACKET
28	PW06	FLAT WASHER ¼"
29	PLW02	LOCK WASHER ¼"
30	PS11M	PHLP HD SCR M6-1 X 16
31	P9984031	BRACKET
32	P9984032	DUST HOOD
33	P9984033	GUARD PLATE
34	PW06	FLAT WASHER ¼"
35	PLW02	LOCK WASHER ¼"
36	PS11M	PHLP HD SCR M6-1 X 16
37	P9984037	GUARD PLATE
38	PW06	FLAT WASHER ¼"
39	PS03M	PHLP HD SCR M6-1 X 8
40	P9984040	"U" HANDLE
41	PS16M	PHLP HD SCR M8-1.25 x 16
42	PN03M	HEX NUT M8-1.25
43	P9984043	STAR KNOB M10-1.5 X 15
44	P9984044	EYE BOLT M10-1.5 X 12
45	PB01M	HEX BOLT M10-1.5 X 30
46	P9984046	ELECTRICITY LABEL
47	P9984047	READ MANUAL LABEL
48	P9984048	SAFETY GLASSES LABEL
49	P9984049	UNPLUG MACHINE LABEL

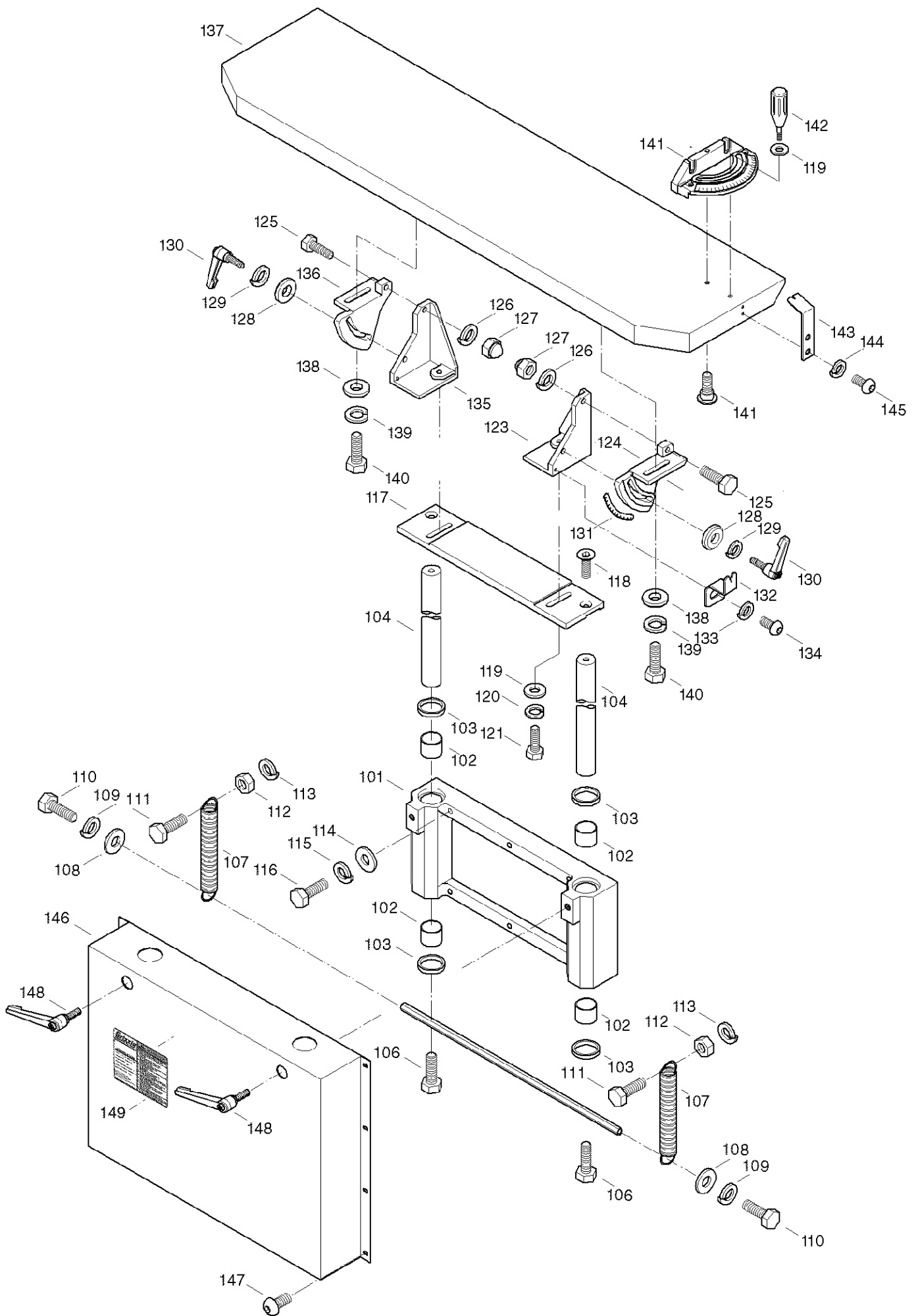

REF	PART #	DESCRIPTION
101	P9984101	ELEVATION BLOCK
102	P9984102	BRUSH
103	P9984103	SEAL
104	P9984104	SHAFT
105	P9984105	LINK
106	PB07M	HEX BOLT M8-1.25 X 25
107	P9984107	SPRING
108	PW07	FLAT WASHER 5/16"
109	PLW01	LOCK WASHER 5/16"
110	PB06M	HEX BOLT M8-1.25 X 12
111	PB34M	HEX BOLT M10-1.5 X 60
112	PN02M	HEX NUT M10-1.5
113	PLW06M	LOCK WASHER 10mm
114	PW07	FLAT WASHER 5/16"
115	PLW01	LOCK WASHER 5/16"
116	PB30M	HEX BOLT M8-1.25 X 55
117	P9984117	ADJUSTMENT PLATE
118	PFH14M	FLAT HD ALLEN SCR M10-1.5 X 25
119	PW04M	FLAT WASHER 10mm
120	PLW06M	LOCK WASHER 10mm
121	PB14M	HEX BOLT M10-1.5 X 35
122	P9984122	TABLE UNIT
123	P9984123	BRACKET (R)
124	P9984124	ADJUSTMENT BASE (R)
125	PB14M	HEX BOLT M10-1.5 X 35
126	PLW06M	LOCK WASHER 10mm
127	PN02M	HEX NUT M10-1.5
128	PW04M	FLAT WASHER 10mm
129	PLW06M	LOCK WASHER 10mm
130	P9984130	LOCK HANDLE M10-1.5 X 35
131	P9984131	INDICATOR SCALE
132	P9984132	POINTER
133	PLW01M	LOCK WASHER 5mm
134	PS09M	PHLP HD SCR M5-0.8 X 10
135	P9984135	BRACKET (L)
136	P9984136	ADJUSTMENT BASE (L)
137	P9984137	OUTSIDE TABLE
138	PW02	FLAT WASHER 3/8"
139	PLW06M	LOCK WASHER 10mm
140	PB01M	HEX BOLT M10-1.5 X 30
141	P9984141	MITER GAUGE
142	P9984142	MITER GAUGE HANDLE 5/16"
143	P9984143	POINTER
144	PLW02M	LOCK WASHER 4mm
145	PS17M	PHLP HD SCR M4-0.7 x 6
146	P9984146	COVER
147	PS03M	PHLP HD SCR M6-1.0 X 8
148	P9984148	LOCK HANDLE M12-1.75 X 40
149	P9984149	ID/WARNING LABEL G9984
149	P9985149	ID/WARNING LABEL G9985

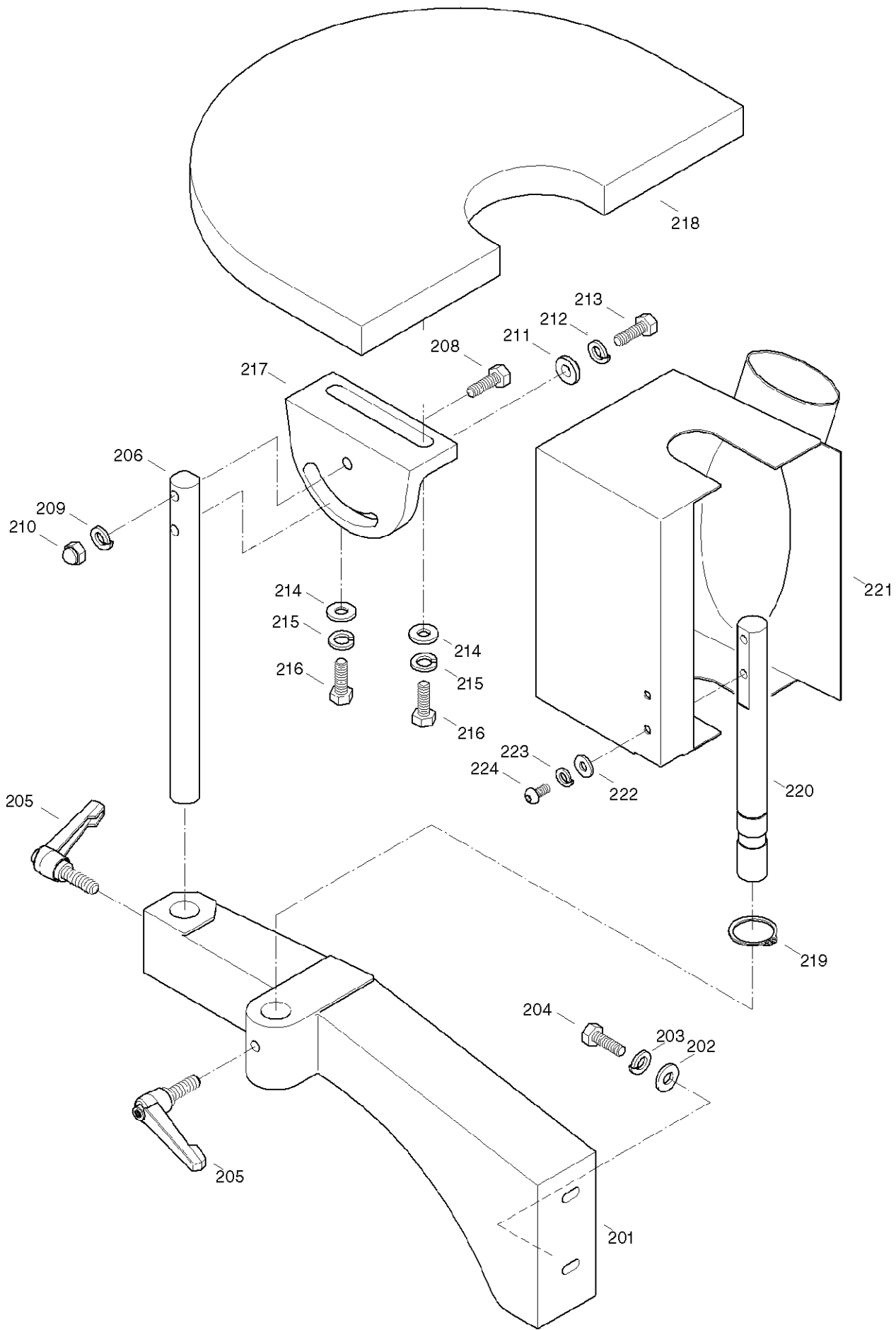

REF	PART #	DESCRIPTION
201	P9984201	SIDE TABLE SUPPORT
202	PW02	FLAT WASHER $\frac{3}{8}$ "
203	PLW06M	LOCK WASHER 10mm
204	PB01M	HEX BOLT M10-1.5 X 30
205	P9984205	LOCK HANDLE M10-1.5 X 25
206	P9984206	SHAFT
208	PB73M	HEX BOLT M10-1.5 X 50
209	PLW06M	LOCK WASHER 10mm
210	PN25M	HEX NUT ACORN M10-1.5
211	PW04M	FLAT WASHER 10mm
212	PLW06M	LOCK WASHER 10mm
213	PB14M	HEX BOLT M10-1.5 X 35
214	PW04M	FLAT WASHER 10mm
215	PLW06M	LOCK WASHER 10mm
216	PB74M	HEX BOLT M10-1.5 X 20
217	P9984217	ADJUSTMENT BASE
218	P9984218	SIDE SANDING TABLE
219	PR11M	EXT RETAINING RING 25mm
220	P9984220	SHAFT
221	P9984221	DUST HOOD
222	PW07	FLAT WASHER $\frac{5}{16}$ "
223	PLW01	LOCK WASHER $\frac{5}{16}$ "
224	PS16M	PHLP HD SCR M8-1.25 x 16

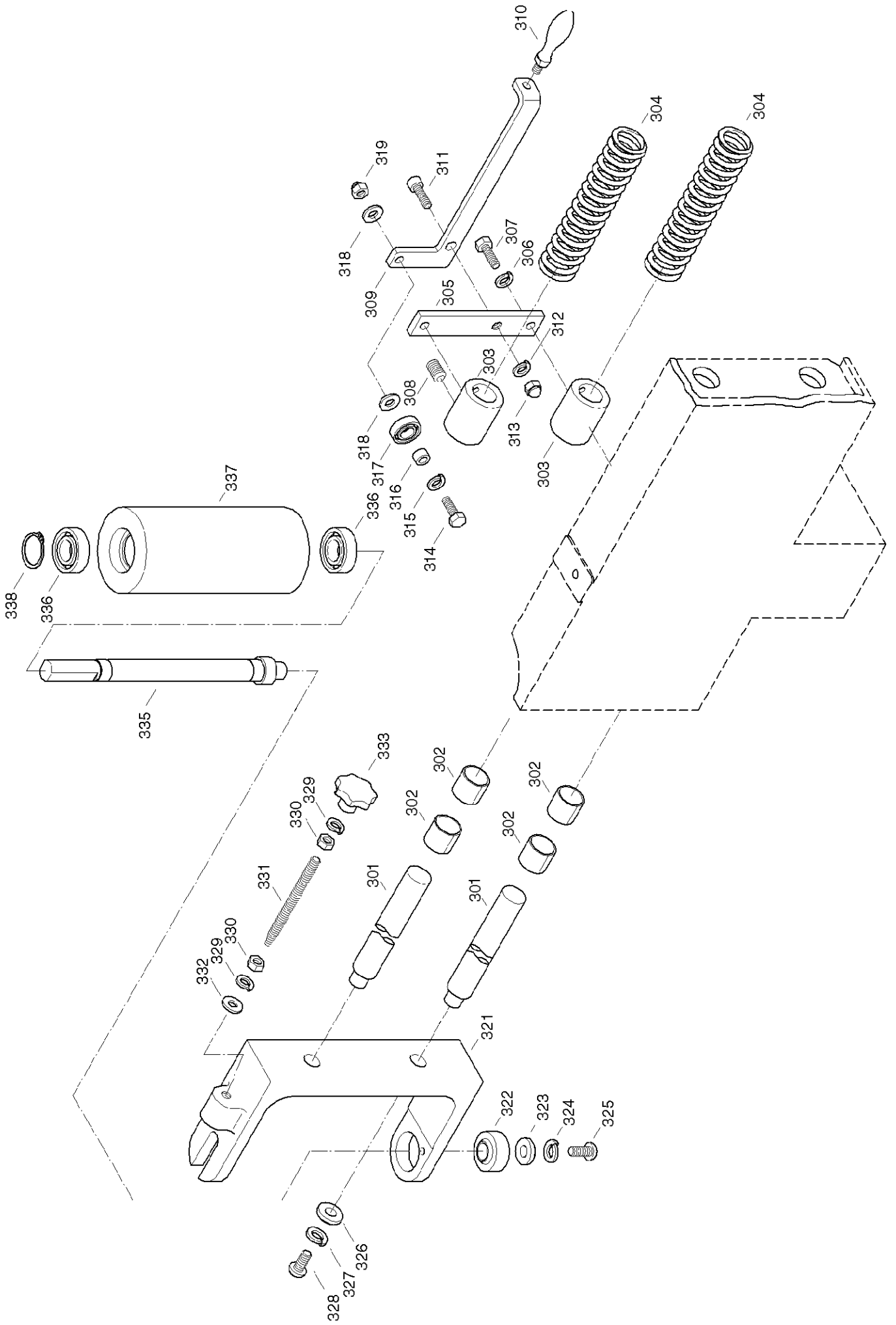

REF	PART #	DESCRIPTION
301	P9984301	SHAFT
302	P9984302	BRUSH
303	P9984303	STOPPER BLOCK
304	P9984304	SPRING
305	P9984305	PLATE
306	PLW06M	LOCK WASHER 10mm
307	PB74M	HEX BOLT M10-1.5 X 20
308	PSS30M	SET SCREW M10-1.5 X 10
309	P9984309	LEVER
310	P9984310	HANDLE M10-1.5
311	PSB70M	CAP SCREW M10-1.5 X 30
312	PLW05M	LOCK WASHER 12mm
313	PN26M	HEX NUT ACORN M12-1.75
314	PB01M	HEX BOLT M10-1.5 X 30
315	PLW06M	LOCK WASHER 10mm
316	P9984316	BUSHING
317	P6003	BEARING 6003LLB
318	PW04M	FLAT WASHER 10mm
319	PN25M	HEX NUT ACORN M10-1.5
321	P9984321	BRACKET
322	P9984322	SPHERICAL BEARING PB20
323	PW04M	FLAT WASHER 10mm
324	PLW06M	LOCK WASHER 10mm
325	PS41M	PHLP HD SCR M10-1.5 X 25
326	PW04M	FLAT WASHER 10mm
327	PLW06M	LOCK WASHER 10mm
328	PS41M	PHLP HD SCR M10-1.5 X 25
329	PLW07	LOCK WASHER ½"
330	PN09M	HEX NUT M12-1.75
331	P9984331	THREADED ROD M12-1.75 X 140
332	PW01	FLAT WASHER ½"
333	P9984333	STAR KNOB
335	P9984335	SHAFT
336	P6205	BEARING NSK6205
337	P9984337	ROLLER
338	PR11M	EXT RETAINING RING 25mm

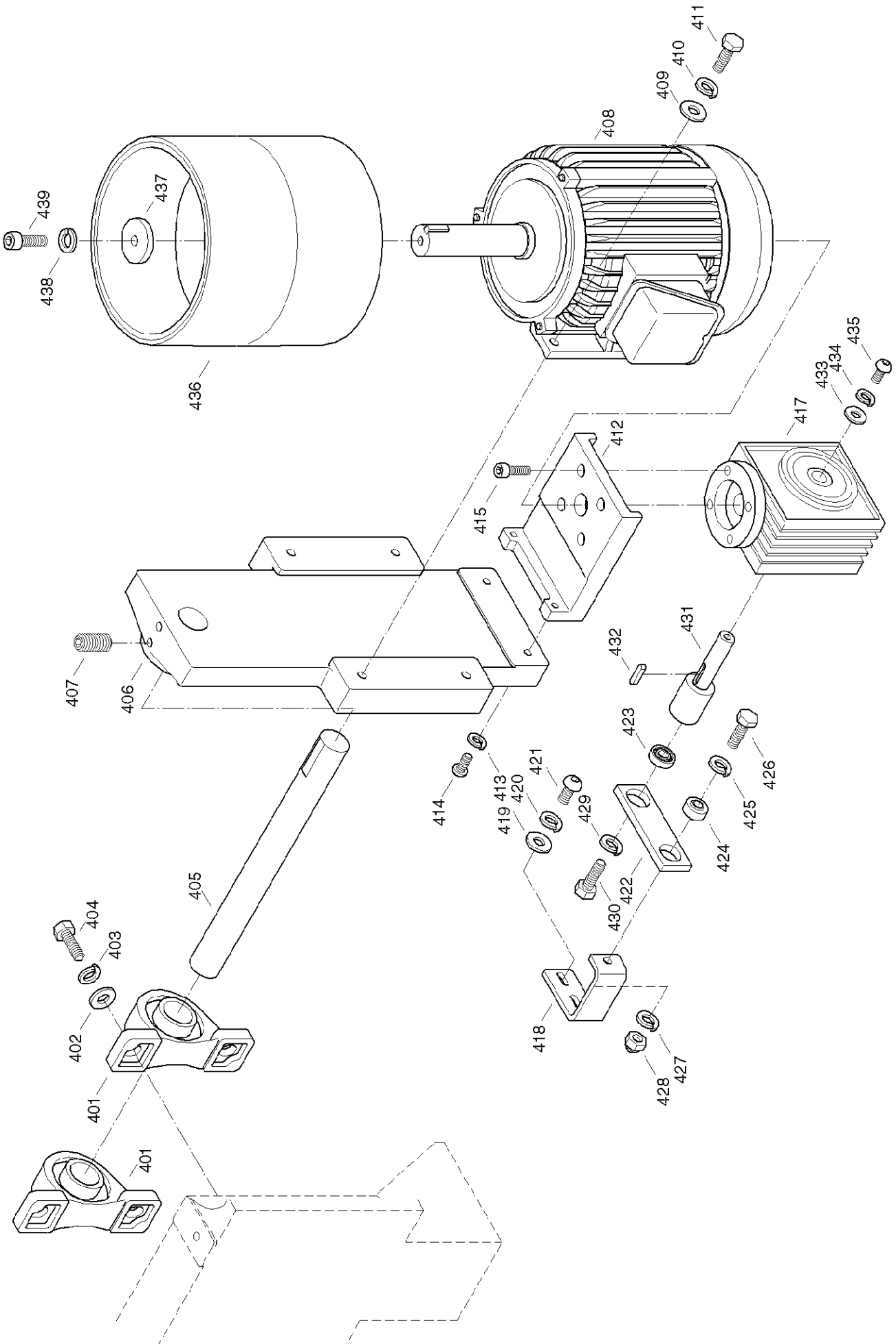

REF	PART #	DESCRIPTION
401	P9984401	PILLOW BLOCK BEARING
402	PW01	FLAT WASHER 1/2"
403	PLW05M	LOCK WASHER 12mm
404	PB35M	HEX BOLT M12-1.75 X 40
405	P9984405	SHAFT
406	P9984406	MOTOR BASE
407	PSS30M	SET SCREW M10-1.5 X 10
408	P9984408	3 H.P. 220V 1750 R.P.M. MOTOR (SINGLE PHASE)
408	P9985408	3 H.P. 220V 1750 R.P.M. MOTOR (THREE PHASE)
409	PW02	FLAT WASHER 3/8"
410	PLW06M	LOCK WASHER 10mm
411	PB01M	HEX BOLT M10-1.5 X 30
412	P9984412	BRACKET
413	PLW01	LOCK WASHER 5/16"
414	PS42M	PHLP HD SCR M8-1.25 X 35
415	PSB11M	CAP SCREW M8-1.25 X 16
417	P9984417	REDUCER CASING
418	P9984418	BRACKET
419	PW07	FLAT WASHER 5/16"
420	PLW01	LOCK WASHER 5/16"
421	PS04M	PHLP HD SCR M8-1.25 X 20
422	P9984422	BEARING HOUSING
423	P6001	BEARING 6001LLB
424	P9984424	SPHERICAL BEARING PB10
425	PLW06M	LOCK WASHER 10mm
426	PB14M	HEX BOLT M10-1.5 X 35
427	PLW06M	LOCK WASHER 10mm
428	PN25M	HEX NUT ACORN M10-1.5
429	PLW05M	LOCK WASHER 12mm
430	PB25M	HEX BOLT M12-1.75 X 25
431	P9984431	CAM
432	PK42M	KEY 6 X 6 X 30
433	PW01M	FLAT WASHER 8mm
434	PLW01	LOCK WASHER 5/16"
435	PS04M	PHLP HD SCR M8-1.25 X 20
436	P9984436	DRIVE WHEEL
437	PW06M	FLAT WASHER 12
438	PLW05M	LOCK WASHER 12mm
439	PSB36M	CAP SCREW M12-1.75 X 25

NOTES

NOTES

WARRANTY AND RETURNS

Grizzly Industrial, Inc. warrants every product it sells for a period of **1 year** to the original purchaser from the date of purchase. This warranty does not apply to defects due directly or indirectly to misuse, abuse, negligence, accidents, repairs or alterations or lack of maintenance. This is Grizzly's sole written warranty and any and all warranties that may be implied by law, including any merchantability or fitness, for any particular purpose, are hereby limited to the duration of this written warranty. We do not warrant or represent that the merchandise complies with the provisions of any law or acts unless the manufacturer so warrants. In no event shall Grizzly's liability under this warranty exceed the purchase price paid for the product and any legal actions brought against Grizzly shall be tried in the State of Washington, County of Whatcom.

We shall in no event be liable for death, injuries to persons or property or for incidental, contingent, special, or consequential damages arising from the use of our products.

To take advantage of this warranty, contact us by mail or phone and give us all the details. We will then issue you a "Return Number," which must be clearly posted on the outside as well as the inside of the carton. We will not accept any item back without this number. Proof of purchase must accompany the merchandise.

The manufacturers reserve the right to change specifications at any time because they constantly strive to achieve better quality equipment. We make every effort to ensure that our products meet high quality and durability standards and we hope you never need to use this warranty.

Please feel free to write or call us if you have any questions about the machine or the manual.

Thank you again for your business and continued support. We hope to serve you again soon.

WARRANTY CARD

Name _____
Street _____
City _____ State _____ Zip _____
Phone Number _____ E-Mail _____ FAX _____
MODEL # _____ Order # _____ Serial # _____

The following information is given on a voluntary basis. It will be used for marketing purposes to help us develop better products and services. Of course, all information is strictly confidential.

- How did you learn about us?
 Advertisement Friend
 Catalog Card Deck
 World Wide Web
 Other _____
- Which of the following magazines do you subscribe to.
 American Woodworker Practical Homeowner
 Cabinetmaker Shop Notes
 Family Handyman Today's Homeowner
 Fine Homebuilding WOOD
 Fine Woodworking Wooden Boat
 Home Handyman Woodshop News
 Journal of Light Construction Woodsmith
 Old House Journal Woodwork
 Popular Mechanics Woodworker
 Popular Science Woodworker's Journal
 Popular Woodworking Workbench
 Other _____
- Which of the following woodworking/remodeling shows do you watch?
 Backyard America The New Yankee Workshop
 Home Time This Old House
 The American Woodworker Woodwright's Shop
 Other _____
- What is your annual household income?
 \$20,000-\$29,999 \$60,000-\$69,999
 \$30,000-\$39,999 \$70,000-\$79,999
 \$40,000-\$49,999 \$80,000-\$89,999
 \$50,000-\$59,999 \$90,000 +
- What is your age group?
 20-29 50-59
 30-39 60-69
 40-49 70 +
- How long have you been a woodworker?
 0 - 2 Years 8 - 20 Years
 2 - 8 Years 20+ Years
- How would you rank your woodworking skills?
 Simple Advanced
 Intermediate Master Craftsman
- What stationary woodworking tools do you own? Check all that apply.
 Air Compressor Panel Saw
 Band Saw Planer
 Drill Press Power Feeder
 Drum Sander Radial Arm Saw
 Dust Collector Shaper
 Horizontal Boring Machine Spindle Sander
 Jointer Table Saw
 Lathe Vacuum Veneer Press
 Mortiser Wide Belt Sander
 Other _____
- How many of your woodworking machines are Grizzly? _____
- Which benchtop tools do you own? Check all that apply.
 1" x 42" Belt Sander 6" - 8" Grinder
 5" - 8" Drill Press Mini Lathe
 8" Table Saw 10" - 12" Thickness Planer
 8" - 10" Bandsaw Scroll Saw
 Disc/Belt Sander Spindle/Belt Sander
 Mini Jointer
 Other _____
- How many of the machines checked above are Grizzly? _____
- Which portable/hand held power tools do you own? Check all that apply.
 Belt Sander Orbital Sander
 Biscuit Joiner Palm Sander
 Circular Saw Portable Planer
 Detail Sander Saber Saw
 Drill/Driver Reciprocating Saw
 Miter Saw Router
 Other _____
- What machines/supplies would you like Grizzly Industrial to carry?

- What new accessories would you like Grizzly Industrial to carry?

- What other companies do you purchase your tools and supplies from?

- Do you think your purchase represents good value?
 Yes No
- Would you recommend Grizzly Industrial to a friend?
 Yes No
- Would you allow us to use your name as a reference for Grizzly customers in your area? **Note: We never use names more than three times.**
 Yes No
- Comments: _____

FOLD ALONG DOTTED LINE



Place
Stamp
Here



GRIZZLY INDUSTRIAL, INC.
P.O. BOX 2069
BELLINGHAM, WA 98227-2069



FOLD ALONG DOTTED LINE

Send a Grizzly Catalog to a friend:

Name _____
Street _____
City _____ State _____ Zip _____

TAPE ALONG EDGES--PLEASE DO NOT STAPLE

