

LIFEBREATH[®]

CLEAN • FRESH • AIR

OPERATION AND INSTALLATION MANUAL

Contains
ControlAir 15

For Models:

95MAX

155MAX

200MAX

MAXTOP

195DCS

300DCS

200ERV

200ERV D

**IMPORTANT - PLEASE READ THIS
MANUAL BEFORE INSTALLING UNIT**

CAUTION

Before installation, careful consideration **must** be given to how this system will operate if connected to any other piece of mechanical equipment, i.e. a forced air furnace or air handler, operating at a higher static. After installation, the compatibility of the two pieces of equipment **must** be confirmed by measuring the airflow's of the Heat Recovery Ventilator (HRV) or Energy Recovery Ventilator (ERV) by using the balancing procedure found in this manual.

It is always important to assess how the operation of any HRV/ERV may interact with vented combustion equipment (ie. Gas Furnaces, Oil Furnaces, Wood Stoves, etc.).

NEVER install a ventilator in a situation where its normal operation, lack of operation or partial failure may result in the backdrafting or improper functioning of vented combustion equipment!!!

TO BE COMPLETED BY CONTRACTOR AFTER INSTALLATION

Installing Contractor

Telephone / Contact

Serial Number

Installation Date

Model



*** LEAVE FOR HOMEOWNER**

NOTE: Due to ongoing research and product development, specifications, ratings and dimensions are subject to change without notice.



Table of Contents

Introduction.....	2
Warranty	2
ERV Questions & Answers	3
Climate Map	4
Technical Data - Model 95MAX	5
Technical Data - Model 155MAX	6
Technical Data - Model 200MAX	7
Technical Data - Model MAXTOP.....	8
Technical Data - Model 195DCS	9
Technical Data - Model 300DCS	10
Technical Data - Model 200ERV	11
Technical Data - Model 200ERV D	12

Function and Control

Operation of the ControlAir 15	13
Glossary of Terms	13
To Select Mode of Operation.....	14
Optional Remote Controls	15
Using the Dehumidistat.....	16
Schematic Diagram - Model 95MAX	17

Installation

Installation	18
• Location	
• Mounting the HRV/ERV	
• Electrical	
• Installing the Drain Line and "P" Trap	
Installing Air Ducts	19
• Outside Weatherhoods	
• Locating the Weatherhoods	
• Installing Ducting from Weatherhoods to the HRV/ERV	
• Warmside Ducting	
Supply Air Ducting	20
Stale Air Exhaust System	20
Dampers and Grilles	20
Installation Diagrams	21 - 24
Air Flow Balancing	25

Maintenance

Maintenance Routine For HRV	27
Maintenance Routine For ERV	28
Troubleshooting.....	29
Wiring Diagram	31

INTRODUCTION

HRV - Aluminum Core

A Heat Recovery Ventilator (HRV) is designed to provide fresh air into a building while exhausting an equal amount of stale air. During the winter months, the incoming cold fresh air is warmed by utilizing the heat recovered from the stale air before it is exhausted to the outdoors. During summer months when the indoor space is air conditioned, the Heat Recovery Ventilator will help in cooling the incoming fresh air with the stale air that is being exhausted.

ERV - Enthalpic Paper Core

An Energy Recovery Ventilator (ERV) is designed to provide fresh air into a building while exhausting an equal amount of stale air. An ERV is designed for use in warm humid areas with heavy air conditioning use. The ERV will transfer both sensible and latent heat from the incoming fresh air to the outgoing stale air thereby reducing the load (due to ventilation) on the air conditioning system.

ERVs are not suitable for climates where the temperature drops below -4°C (25°F).

WARRANTY

All Heat Recovery Ventilators carry a Lifetime Warranty on the heat recovery core and a 5 (five) year replacement parts warranty.

All Energy Recovery Ventilators carry a 5 (five) year warranty on the energy recovery core and a 5 (five) year replacement parts warranty.

During the warranty period, if any core experiences a failure or perforation caused by normal use while owned by the original purchaser, a replacement core (FOB our plant) will be supplied at no expense.



ERV Questions & Answers

What is the difference between an HRV and an ERV?

The core in an HRV (Heat Recovery Ventilator) transfers heat from one air stream to the other. This is called *sensible heat*. The term ERV (Energy Recovery Ventilator) is usually used to describe a unit with an enthalpic core that transfers moisture as well as heat from one air stream to the other. This (moisture transfer) is called *latent heat*.

Enthalpic - what does it mean?

Enthalpy is the term used to describe the energy content of air. This energy is a combination of the sensible and latent heat. Therefore, a core which transfers energy is called an enthalpic core.

Is an ERV better than an HRV?

NOT NECESSARILY!! In cold climates such as most of North America, an HRV works better than an ERV. This is because the air inside the home during the winter months will be more humid than the outside air. An ERV would transfer the latent heat (humidity) from the exhaust air back into the incoming airstream. This will aggravate moisture problems in the home and encourage the growth of mold and mildew. If the air in the home is too dry for comfort, an ERV will not help. A humidifier should be used to increase the humidity to a comfortable level.

Where do you use an ERV instead of an HRV?

An ERV is recommended for warm, humid areas with heavy air conditioning use. As there is no defrost in an ERV it is not recommended for areas where the temperature drops below -4°C (25°F).

Why transfer moisture in the summer (cooling season)?

The enthalpic core will allow moisture to be transferred from a humid air flow to a dry air flow. This property is useful in the cooling season if an air conditioning system is used to lower the indoor humidity. You will then have dry, cool air in the exhaust of the ERV, and warm humid air in the supply stream. With these conditions, the ERV will be able to transfer the moisture and heat of the supply air to the exhaust air. In this way, the ERV will supply to the home air which is cooler and drier than outside. Remember that an ERV is not a dehumidifier, and on its own will not take moisture out of the air.

So why use an ERV?

A properly operating air conditioner will not only lower the temperature in your house, but will also lower the humidity level. This prevents an uncomfortable cold

and damp situation. In fact, about 2/3 of the energy used by the air conditioner system is to remove moisture. Therefore, when ventilating in the summer, less moisture brought into the home means less work for the air conditioner, and energy savings for you.

During the winter, an ERV recovers some humidity from the exhaust air, reducing the need for humidification, if the required ventilation rate would make the home too dry.

What's the difference between this type of core and a rotary type?

Here's a list of characteristics of the fixed plate core.

1. No rotating parts, so maintenance is easy and the unit lasts a long time.
2. It is very flexible in terms of installation.
3. The core can easily be changed.
4. Because the supply and exhaust air streams are completely separate, there is very little cross leakage of any dust or germs.

Can the core become clogged with dust?

Because the surface of the core is a turbulent flow area, dust sticks to it easily; however, because the inside of the element is a laminar flow area, virtually no dust sticks to it.

What is the maintenance?

About once a year you should use a vacuum cleaner to remove the dust from the core's surface. DO NOT WASH WITH WATER!!

Is an air filter needed?

To prevent clogging of the core, an air filter should always be installed on the supply and exhaust sides of the core.

How much ventilation do I need?

During seasons when your windows and doors are closed, the ERV should operate continuously when the dwelling is occupied, and either continuously or intermittently when not occupied.

For most installations the ERV will normally be set to operate continuously on low speed with the option of going to high speed as the need arises. For example; if you are entertaining and there is a large number of people present (some may be smoking), the unit should be switched to high speed.





Your ERV may be equipped with automatic or manual switches, but all ERVs will have a manual speed control override.

LIFEBREATH®

CLEAN • FRESH • AIR

Select the correct HRV/ERV to match your climate



 <p>Severe Conditions HRV required</p>	 <p>Moderate Conditions HRV recommended</p>
 <p>Pacific Conditions HRV recommended ERV optional*</p>	 <p>Arid Zone - Dry Climate HRV recommended</p>
 <p>Extreme Area** - High Humidity ERV recommended*</p>	

* ERV not recommended where temperatures fall below 25°F (-4°C) for more than five days.
 ** ERV's are recommended in regions where high outdoor humidity is cause for operating air conditioning/dehumidification more frequently than heating system.

ENGINEERING DATA

THERMALLY CONDUCTIVE, PATENTED ALUMINUM CORE

The cross-flow heat recovery core transfers heat between the two airstreams. It is easily removed for cleaning or service.

MOTORS AND BLOWERS - Each air stream has one centrifugal blower driven by a common PSC motor. 5 speed fan operation. 120 VAC, .8 Amps.

FILTERS - Washable air filters in exhaust and supply air streams.

MOUNTING THE HRV - Four threaded inserts at corners of the cabinet designed to accept PVC reinforced polyester straps that are supplied with the unit.

DEFROST - Recirculating defrost system.

CASE - Twenty gauge prepainted galvanized steel (G60) for superior corrosion resistance. Insulated to prevent exterior condensation. Drain connections 2 - 1/2" (12 mm) OD.

CONTROLS - ControlAir 15

WEIGHT 52 lbs. (23.6 kg) **SHIPPING WEIGHT** 56 lbs. (25.4 kg)

PERFORMANCE

HVI CERTIFIED

Net supply airflow in cfm (L/s) against external static pressure

E.S.P	cfm	L/s
@ 0.1" (25 Pa)	89	(42)
@ 0.2" (50 Pa)	78	(37)
@ 0.3" (75 Pa)	64	(30)
@ 0.4" (100 Pa)	36	(17)

Maximum Temperature Recovery 74%

Sensible Effectiveness @ 64 cfm (30 L/s) (CSA C439M) 80%

Sensible Efficiency @ 64 cfm (30 L/s) 32°F (0°C) 75%

Sensible Efficiency @ 64 cfm (30 L/s) -13°F (-25°C) 75%

VAC @ 60HZ 120

WATTS / Low speed 35

WATTS / High speed 136

Amp rating 0.8

DIMENSIONS 95MAX inches (mm)

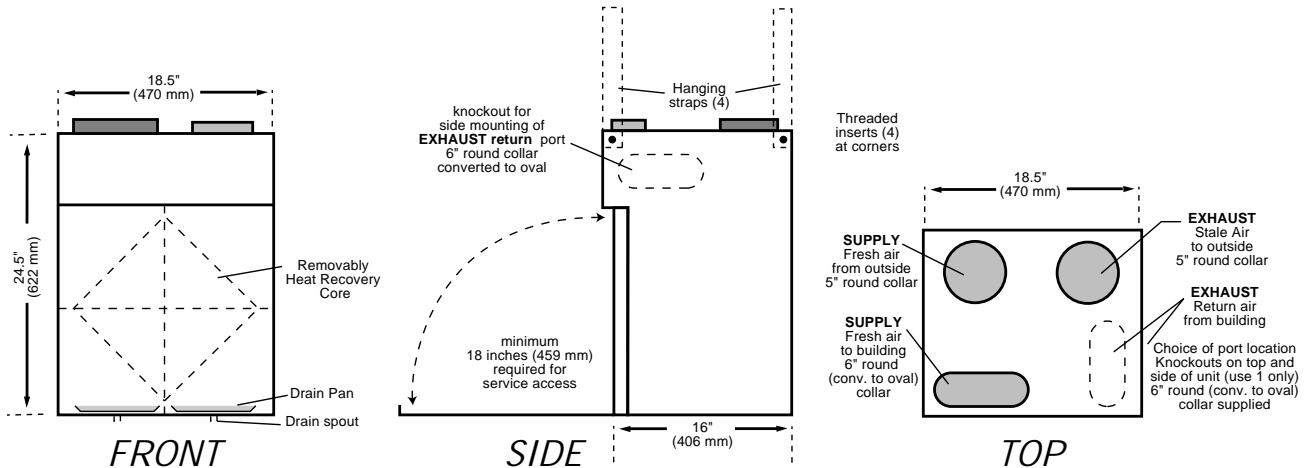

OPTIONS

99-104 **Digital Electronic Timer** - 20/40/60 min.

99-105 **Programmable Ventilation Control (PVC)** includes Programmable Time Clock, Dehumidistat and Air Sentry™

99-109 **Air Sentry™** Air Quality Monitor designed to accept remotely mounted Control Pad

99-250 **Ventilation Dehumidistat** - Dehumidistat designed to accept remotely mounted Control Pad

99-163 **Duct Heater w/ Electronic SCR Thermostat**, 1 Kw, 6" (150 mm)

99-185 **Weatherhoods, Two** - 5" (125 mm) c/w 1/4" (6 mm) mesh screen

All units conform to CSA and UL standards.

WARRANTY

Units carry a LIFETIME warranty on the heat recovery core and a 5 year replacement parts warranty.

DATE: _____

PROJECT: _____

MECHANICAL CONTRACTOR: _____

ENGINEERING DATA

THERMALLY CONDUCTIVE, PATENTED ALUMINUM CORE

The cross-flow heat recovery core transfers heat between the two airstreams. It is easily removed for cleaning or service.

MOTORS AND BLOWERS - Each air stream has one centrifugal blower driven by a common PSC motor. 5 speed fan operation. 120 VAC, 1.0 Amps.

FILTERS - Washable air filters in exhaust and supply air streams.

MOUNTING THE HRV - Four threaded inserts at corners of case designed to accept four reinforced polyester straps that are supplied with the unit.

DEFROST - Recirculating damper defrost system.

DEHUMIDISTAT - Adjustable Internal Dehumidistat.

CASE - Twenty gauge prepainted galvanized steel (G60) for superior corrosion resistance. Insulated to prevent exterior condensation. Drain connections 2 - 1/2" (12 mm) OD.

CONTROLS - ControlAir 15

WEIGHT 71 lbs. (32.5 kg) **SHIPPING WEIGHT** 73 lbs. (33.5 kg)

PERFORMANCE

HVI CERTIFIED

Net supply airflow in cfm (L/s) against external static pressure

E.S.P	cfm	L/s
@ 0.1" (25 Pa)	169	(80)
@ 0.2" (50 Pa)	161	(76)
@ 0.3" (75 Pa)	150	(71)
@ 0.4" (100 Pa)	130	(61)
@ 0.5" (125 Pa)	56	(26)

Maximum Temperature Recovery	83%
Sensible Effectiveness @ 64 cfm (30 L/s) (CSA C439M)	76%
Sensible Efficiency @ 64 cfm (30 L/s) 32°F (0°C)	70%
Sensible Efficiency @ 64 cfm (30 L/s) -13°F (-25°C)	70%
VAC @ 60HZ	120
WATTS / Low speed	49
WATTS / High speed	120
Amp rating	1.0

DIMENSIONS 155MAX inches (mm)

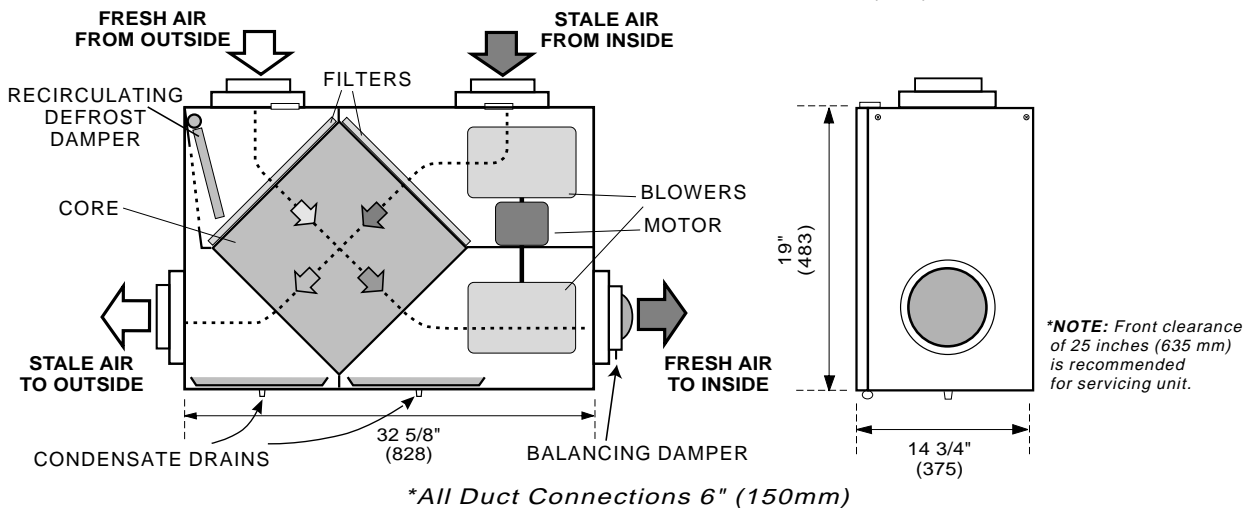

OPTIONS

99-104 **Digital Electronic Timer** - 20/40/60 min.

99-105 **Programmable Ventilation Control (PVC)**
includes Programmable Time Clock, Dehumidistat and Air Sentry™

99-109 **Air Sentry™** Air Quality Monitor designed to accept remotely mounted Control Pad

99-250 **Ventilation Dehumidistat** - Dehumidistat designed to accept remotely mounted Control Pad.

99-163 **Duct Heater w/ Electronic SCR Thermostat**, 1 Kw, 6" (150 mm)

99-164 **Duct Heater w/ Electronic SCR Thermostat**, 2 Kw, 6" (150 mm)

99-186 **Weatherhoods, Two** - 6" (150 mm) c/w 1/4" (6 mm) mesh screen

All units conform to CSA and UL standards.

WARRANTY

Units carry a LIFETIME warranty on the heat recovery core and a 5 year replacement parts warranty.

DATE: _____

PROJECT: _____

MECHANICAL CONTRACTOR: _____

NUTECH
ENERGY SYSTEMS INC.

511 McCormick Blvd.
London, Ontario N5W 4C8
Ph: (519) 457-1904
Fx: (519) 457-1676
Email: nutech@lifebreath.com
Website: www.lifebreath.com

ENGINEERING DATA

THERMALLY CONDUCTIVE, PATENTED ALUMINUM CORE
The cross-flow heat recovery core transfers heat between the two airstreams. It is easily removed for cleaning or service.

MOTORS AND BLOWERS - Each air stream has one centrifugal blower driven by a common PSC motor. 5 speed fan operation. 120 VAC, 1.4 Amps.

FILTERS - Washable air filters in exhaust and supply air streams.

MOUNTING THE HRV - Four threaded inserts at corners of case designed to accept four reinforced polyester straps that are supplied with the unit.

DEFROST - Recirculating damper defrost system.

DEHUMIDISTAT - Adjustable Internal Dehumidistat.

CASE - Twenty gauge prepainted galvanized steel (G60) for superior corrosion resistance. Insulated to prevent exterior condensation. Drain connections 2 - 1/2" (12 mm) OD.

CONTROLS - ControlAir 15

WEIGHT 71 lbs. (32.5 kg) **SHIPPING WEIGHT** 73 lbs. (33.5 kg)

PERFORMANCE

HVI CERTIFIED

Net supply airflow in cfm (L/s) against external static pressure

E.S.P	cfm	L/s
@ 0.1" (25 Pa)	232	(109)
@ 0.2" (50 Pa)	223	(105)
@ 0.3" (75 Pa)	215	(102)
@ 0.4" (100 Pa)	195	(92)
@ 0.5" (125 Pa)	189	(89)

Maximum Temperature Recovery 81%

Sensible Effectiveness
@ 117 cfm (55 L/s) (CSA C439M) 74%

Sensible Efficiency
@ 117 cfm (55 L/s) 32°F (0°C) 65%

Sensible Efficiency
@ 117 cfm (55 L/s) -13°F (-25°C) 66%

VAC @ 60HZ 120

WATTS / Low speed 87

WATTS / High speed 164

Amp rating 1.4

DIMENSIONS 200MAX inches (mm)

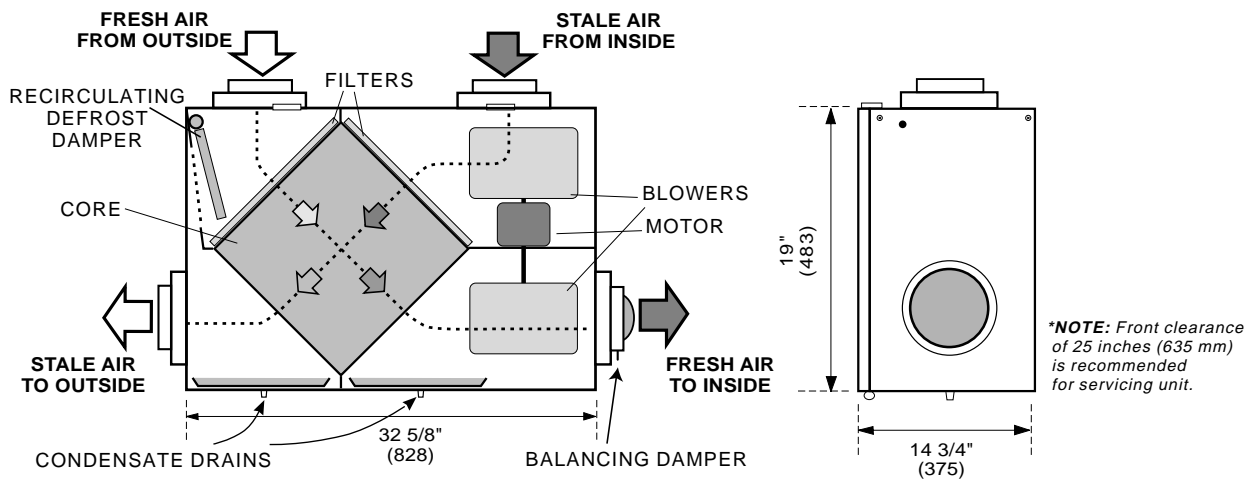

*All Duct Connections 6" (150mm)

OPTIONS

- 99-104 Digital Electronic Timer - 20/40/60 min.
- 99-105 Programmable Ventilation Control (PVC) includes Programmable Time Clock, Dehumidistat and Air Sentry™
- 99-109 Air Sentry™ Air Quality Monitor designed to accept remotely mounted Control Pad
- 99-250 Ventilation Dehumidistat - Dehumidistat designed to accept remotely mounted Control Pad.

- 99-163 Duct Heater w/ Electronic SCR Thermostat, 1 Kw, 6" (150mm)
- 99-164 Duct Heater w/ Electronic SCR Thermostat, 2 Kw, 6" (150mm)
- 99-186 Weatherhoods, Two - 6" (150mm) c/w 1/4" (6mm) mesh screen

All units conform to CSA and UL standards.

WARRANTY

Units carry a LIFETIME warranty on the heat recovery core and a 5 year replacement parts warranty.

DATE: _____

PROJECT: _____

MECHANICAL CONTRACTOR: _____

NUTECH
ENERGY SYSTEMS INC.

511 McCormick Blvd.
London, Ontario N5W 4C8
Ph: (519) 457-1904
Fx: (519) 457-1676
Email: nutech@lifebreath.com
Website: www.lifebreath.com

ENGINEERING DATA

THERMALLY CONDUCTIVE, PATENTED ALUMINUM CORE
The cross-flow heat recovery core transfers heat between the two airstreams. It is easily removed for cleaning or service.

MOTORS AND BLOWERS - Each air stream has one centrifugal blower driven by a common PSC motor. 5 speed fan operation. 120 VAC, 1.4 Amps.

FILTERS - Washable air filters in exhaust and supply air streams.

MOUNTING THE HRV - Four threaded inserts at corners of case designed to accept four reinforced polyester straps that are supplied with the unit.

DEFROST - Recirculating damper defrost system.

DEHUMIDISTAT - Adjustable Internal Dehumidistat.

CASE - Twenty gauge prepainted galvanized steel (G60) for superior corrosion resistance. Insulated to prevent exterior condensation. Drain connections 2 - 1/2" (12 mm) OD.

CONTROLS - ControlAir 15

WEIGHT 87 lbs. (39.5 kg) **SHIPPING WEIGHT** 89 lbs. (40.5 kg)

PERFORMANCE

HVI CERTIFIED

Net supply airflow in cfm (L/s) against external static pressure

E.S.P	cfm	L/s
@ 0.1" (25 Pa)	196	(93)
@ 0.2" (50 Pa)	188	(89)
@ 0.3" (75 Pa)	178	(84)
@ 0.4" (100 Pa)	165	(78)
@ 0.5" (125 Pa)	149	(71)

Maximum Temperature Recovery	80%
Sensible Effectiveness @ 117 cfm (55 L/s) (CSA C439M)	72%
Sensible Efficiency @ 117 cfm (55 L/s) 32°F (0°C)	64%
Sensible Efficiency @ 67 cfm (31 L/s) -13°F (-25°C)	70%
VAC @ 60HZ	120
WATTS / Low speed	74
WATTS / High speed	164
Amp rating	1.4

DIMENSIONS MAXTOP inches (mm)

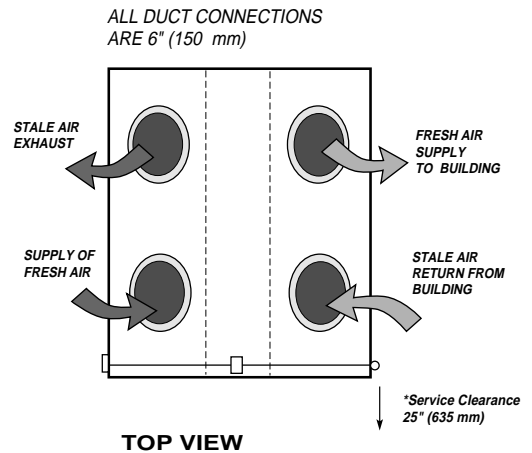
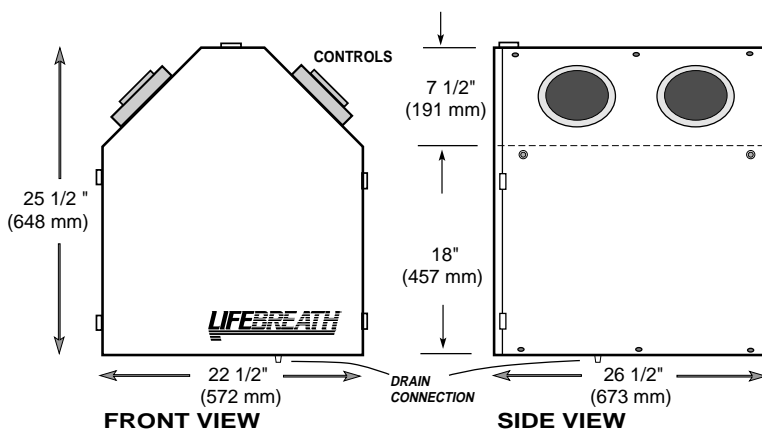

OPTIONS

- 99-104 Digital Electronic Timer - 20/40/60 min.
- 99-105 Programmable Ventilation Control (PVC) includes Programmable Time Clock, Dehumidistat and Air Sentry™
- 99-109 Air Sentry™ Air Quality Monitor designed to accept remotely mounted Control Pad
- 99-250 Ventilation Dehumidistat - Dehumidistat designed to accept remotely mounted Control Pad

- 99-163 Duct Heater w/ Electronic SCR Thermostat, 1 Kw, 6" (150mm)
- 99-164 Duct Heater w/ Electronic SCR Thermostat, 2 Kw, 6" (150mm)
- 99-186 Weatherhoods, Two - 6" (150mm) c/w 1/4" (6mm) mesh screen

All units conform to CSA and UL standards.

WARRANTY

Units carry a LIFETIME warranty on the heat recovery core and a 5 year replacement parts warranty.

DATE: _____

PROJECT: _____

MECHANICAL CONTRACTOR: _____

ENGINEERING DATA

THERMALLY CONDUCTIVE, PATENTED ALUMINUM CORE
The cross-flow heat recovery core transfers heat between the two airstreams. The two cores are arranged for highly efficient counter current airflow.

MOTORS AND BLOWERS - Each air stream has one centrifugal blower driven by a common PSC motor. 5 speed fan operation. 120 VAC, 1.5 Amps.

FILTERS - Washable air filters in exhaust and supply air streams.

MOUNTING THE HRV - Four threaded inserts at corners of case designed to accept four reinforced polyester straps that are supplied with the unit.

DEFROST - Damper defrost system.

DEHUMIDISTAT - Adjustable Internal Dehumidistat.

CASE - Twenty gauge prepainted galvanized steel (G60) for superior corrosion resistance. Insulated to prevent exterior condensation. Drain connections 2 - 1/2" (12 mm) OD.

CONTROLS - ControlAir 15

WEIGHT 106 lbs. (48 kg) **SHIPPING WEIGHT** 108 lbs. (49 kg)

PERFORMANCE

HVI CERTIFIED

Net supply airflow in cfm (L/s) against external static pressure

E.S.P	cfm	L/s
@ 0.1" (25 Pa)	203	(96)
@ 0.2" (50 Pa)	191	(90)
@ 0.3" (75 Pa)	182	(86)
@ 0.4" (100 Pa)	167	(79)
@ 0.5" (125 Pa)	155	(73)

Maximum Temperature Recovery	88%
Sensible Effectiveness @ 117 cfm (55 L/s) (CSA C439M)	88%
Sensible Efficiency @ 117 cfm (55 L/s) 32°F (0°C)	80%
Sensible Efficiency @ 117 cfm (55 L/s) -13°F (-25°C)	77%
VAC @ 60HZ	120
WATTS / Low speed	100
WATTS / High speed	173
Amp rating	1.5

DIMENSIONS 195DCS inches (mm)

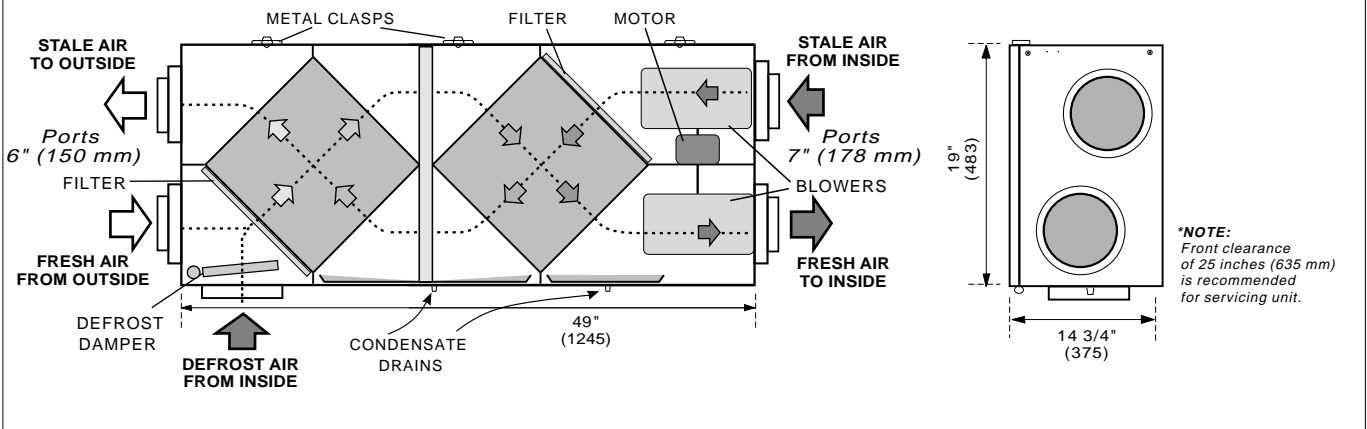

OPTIONS

- 99-104 **Digital Electronic Timer** - 20/40/60 min.
- 99-105 **Programmable Ventilation Control (PVC)**
includes Programmable Time Clock, Dehumidistat and Air Sentry™
- 99-109 **Air Sentry™** Air Quality Monitor designed to accept remotely mounted Control Pad
- 99-250 **Ventilation Dehumidistat** - Dehumidistat designed to accept remotely mounted Control Pad.

- 99-160 **Duct Heater w/ Electronic SCR Thermostat,**
1 Kw, 7" (178 mm)
- 99-161 **Duct Heater w/ Electronic SCR Thermostat,**
2 Kw, 7" (178 mm)
- 99-186 **Weatherhoods, Two - 6" (150 mm)**
c/w 1/4" (6mm) mesh screen

All units conform to CSA and UL standards.

WARRANTY

Units carry a LIFETIME warranty on the heat recovery core and a 5 year replacement parts warranty.

DATE: _____

PROJECT: _____

MECHANICAL CONTRACTOR: _____

NUTECH
ENERGY SYSTEMS INC.
511 McCormick Blvd.
London, Ontario N5W 4C8
Ph: (519) 457-1904
Fx: (519) 457-1676
Email: nutech@lifebreath.com
Website: www.lifebreath.com

ENGINEERING DATA

THERMALLY CONDUCTIVE, PATENTED ALUMINUM CORE
The cross-flow heat recovery core transfers heat between the two airstreams. The two cores are arranged for highly efficient counter current airflow.

MOTORS AND BLOWERS - Each air stream has one centrifugal blower driven by a common PSC motor. 5 speed fan operation. 120 VAC, 2.9 Amps.

FILTERS - Washable air filters in exhaust and supply air streams.

MOUNTING THE HRV - Four threaded inserts at corners of case designed to accept four reinforced polyester straps that are supplied with the unit.

DEFROST - Damper defrost system.

DEHUMIDISTAT - Adjustable Internal Dehumidistat.

CASE - Twenty gauge prepainted galvanized steel (G60) for superior corrosion resistance. Insulated to prevent exterior condensation. Drain connections 2 - 1/2" (12 mm) OD.

CONTROLS - ControlAir 15

WEIGHT 106 lbs. (48 kg) **SHIPPING WEIGHT** 108 lbs. (49 kg)

PERFORMANCE

HVI CERTIFIED

Net supply airflow in cfm (L/s) against external static pressure

E.S.P	cfm	L/s
@ 0.1" (25 Pa)	265	(125)
@ 0.2" (50 Pa)	260	(123)
@ 0.3" (75 Pa)	250	(118)
@ 0.4" (100 Pa)	235	(111)
@ 0.5" (125 Pa)	220	(104)

Maximum Temperature Recovery 90%

Sensible Effectiveness @ 117 cfm (55 L/s) (CSA C439M) 90%

Sensible Efficiency @ 117 cfm (55 L/s) 32°F (0°C) 79%

Sensible Efficiency @ 117 cfm (55 L/s) -13°F (-25°C) 75%

VAC @ 60HZ 120

WATTS / Low speed 150

WATTS / High speed 333

Amp rating 2.9

DIMENSIONS 300DCS inches (mm)

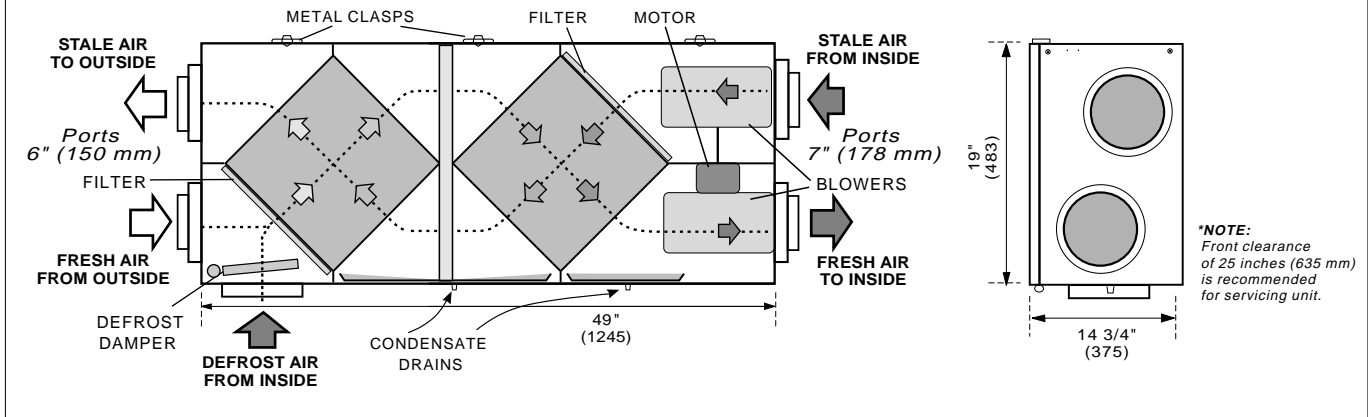

OPTIONS

- 99-104 **Digital Electronic Timer** - 20/40/60 min.
- 99-105 **Programmable Ventilation Control (PVC)** includes Programmable Time Clock, Dehumidistat and Air Sentry™
- 99-109 **Air Sentry™** Air Quality Monitor designed to accept remotely mounted Control Pad.
- 99-250 **Ventilation Dehumidistat** - Dehumidistat designed to accept remotely mounted Control Pad.

- 99-160 **Duct Heater w/ Electronic SCR Thermostat,** 1 Kw, 7" (178 mm)
- 99-161 **Duct Heater w/ Electronic SCR Thermostat,** 2 Kw, 7" (178 mm)
- 99-186 **Weatherhoods, Two - 6" (150mm)** c/w 1/4" (6mm) mesh screen

All units conform to CSA and UL standards.

WARRANTY

Units carry a LIFETIME warranty on the heat recovery core and a 5 year replacement parts warranty.

DATE: _____

PROJECT: _____

MECHANICAL CONTRACTOR: _____

NUTECH
ENERGY SYSTEMS INC.
511 McCormick Blvd.
London, Ontario N5W 4C8
Ph: (519) 457-1904
Fx: (519) 457-1676
Email: nutech@lifebreath.com
Website: www.lifebreath.com

ENGINEERING DATA

LATENT RECOVERY/MOISTURE TRANSFER CORE

The cross-flow energy recovery core transfers heat and water vapour between the two airstreams. It is easily removed for cleaning or service.

MOTORS AND BLOWERS - Each air stream has one centrifugal blower driven by a common PSC motor. 5 speed fan operation. High speed - 120 VAC, 182 Watts.

FILTERS - Washable air filters in exhaust and supply air streams.

MOUNTING THE ERV - Four threaded inserts at corners of case designed to accept four PVC reinforced polyester straps that are supplied with the unit.

CASE - Twenty gauge prepainted galvanized steel (G60) for superior corrosion resistance. Insulated to prevent exterior condensation.

CONTROLS - ControlAir 15

WEIGHT 63 lbs. (28.7 kg) **SHIPPING WEIGHT** 65 lbs. (29.6 kg)

PERFORMANCE

Net supply airflow in cfm (L/s) against external static pressure

E.S.P.	cfm	L/s
@ 0.1" (25 Pa)	214	(101)
@ 0.2" (50 Pa)	206	(97)
@ 0.3" (75 Pa)	193	(91)
@ 0.4" (100 Pa)	184	(87)
@ 0.5" (125 Pa)	170	(80)

Sensible Effectiveness @ 127cfm (60 L/s) (CSA C439M) 67%

Sensible Efficiency 32°F (0°C) 60%

Total Efficiency 55%

VAC @ 60HZ 120

WATTS / Low speed 70

DIMENSIONS 200ERV inches (mm)

*All Duct Connections 6" (150mm)

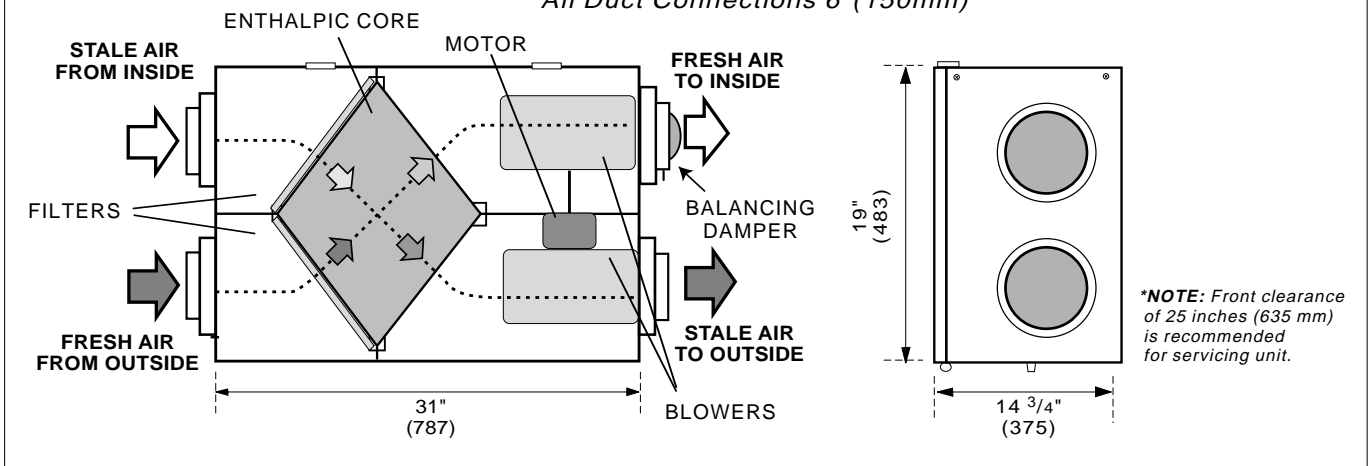

OPTIONS

- 99-104 **Digital Electronic Timer** - 20/40/60 min. (3 wire)
- 99-105 **Deluxe Programmable Control** includes Programmable Time Clock, Dehumidistat and Air Sentry™
- 99-109 **Air Sentry™** Air Quality Monitor designed to accept remotely mounted Control Pad
- 99-186 **Weatherhoods**, Two - 6" (150mm) c/w 1/4" (6mm) mesh screen

WARRANTY

Units carry a 5 year warranty on the energy recovery core and replacement parts.

All units conform to CSA and UL standards.

ERVs are not recommended for regions where the design temperature is below 25°F (-4°C)

DATE: _____

PROJECT: _____

MECHANICAL CONTRACTOR: _____

NUTECH
ENERGY SYSTEMS INC.

511 McCormick Blvd.
London, Ontario N5W 4C8
Ph: (519) 457-1904
Fx: (519) 457-1676
Email: nutech@lifebreath.com
Website: www.lifebreath.com

ENGINEERING DATA

LATENT RECOVERY/MOISTURE TRANSFER CORE

The cross-flow energy recovery core transfers heat and water vapour between the two airstreams. It is easily removed for cleaning or service.

MOTORS AND BLOWERS - Each air stream has one centrifugal blower driven by a common PSC motor. 5 speed fan operation. High speed - 120 VAC, 182 Watts.

FILTERS - Washable air filters in exhaust and supply air streams.

MOUNTING THE ERV - Four threaded inserts at corners of case designed to accept four PVC reinforced polyester straps that are supplied with the unit.

DEFROST - Damper defrost system.

CASE - Twenty gauge prepainted galvanized steel (G60) for superior corrosion resistance. Insulated to prevent exterior condensation.

DRAIN CONNECTIONS - Two - 1/2" (12mm) O.D.

CONTROLS - ControlAir 15

WEIGHT 63 lbs. (28.7 kg) **SHIPPING WEIGHT** 65 lbs. (29.6 kg)

PERFORMANCE

Net supply airflow in cfm (L/s) against external static pressure

E.S.P	cfm	L/s
@ 0.1" (25 Pa)	214	(101)
@ 0.2" (50 Pa)	206	(97)
@ 0.3" (75 Pa)	193	(91)
@ 0.4" (100 Pa)	184	(87)
@ 0.5" (125 Pa)	170	(80)

Sensible Effectiveness @ 127cfm (60 L/s) (CSA C439M) 67%

Sensible Efficiency 32°F (0°C) 60%

Total Efficiency 55%

VAC @ 60HZ 120

WATTS / Low speed 70

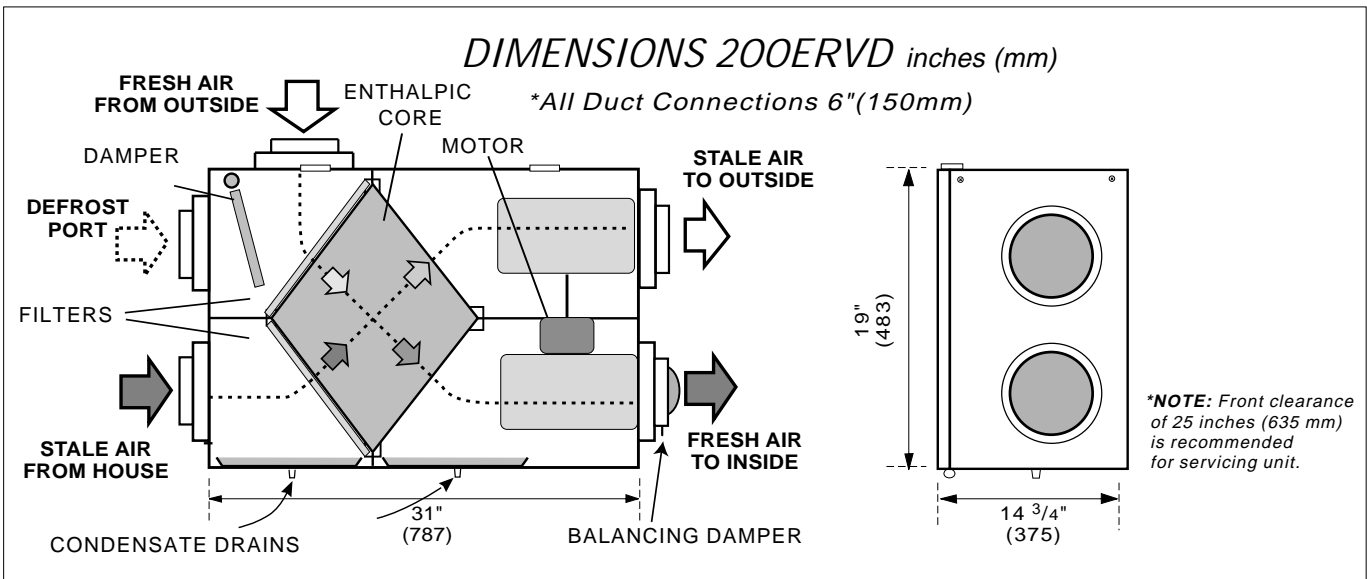

OPTIONS

- 99-104 Digital Electronic Timer - 20/40/60 min. (3 wire)
- 99-105 Deluxe Programmable Control includes Programmable Time Clock, Dehumidistat and Air Sentry™
- 99-109 Air Sentry™ Air Quality Monitor designed to accept remotely mounted Control Pad.
- 99-186 Weatherhoods, Two - 6" (150mm) c/w 1/4" (6mm) mesh screen

WARRANTY

Units carry a 5 year warranty on the energy recovery core and replacement parts.

All units conform to CSA and UL standards.

ERVs are not recommended for regions where the design temperature is below 25°F (-4°C)

DATE: _____

PROJECT: _____

MECHANICAL CONTRACTOR: _____

FUNCTION & CONTROL

Operating the ControlAir 15

Plugging in the HRV/ERV energizes the unit. A self test function will be performed every time the HRV/ERV is energized (refer to "Self Test" for more details). After the self test has completed successfully the HRV/ERV will default to Speed 1. This is the factory default setting. Follow the instructions found on the HRV/ERV door to select desired mode and speed, or refer to the instructions found on the following page.

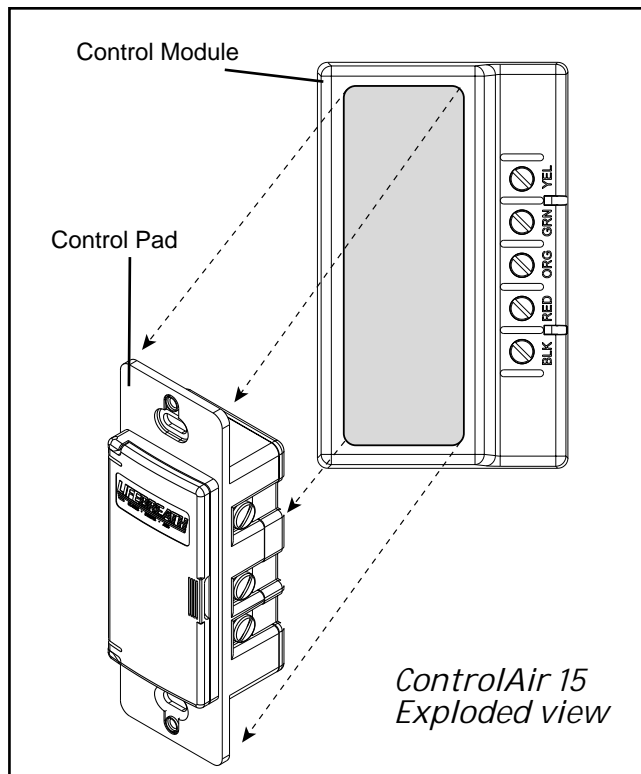

Removing and relocating the Control Pad

The Control Pad can be removed and installed in a remote location (100' wire length max). The Control Pad can be installed in a 2x4 box with a "Decora" type cover plate or can be installed in the optional "Ventilation Dehumidistat" or "Air Sentry". When the Control Pad is installed in a remote location, all optional controls will still be wired to the Control Module on the HRV/ERV. When remotely mounted on its own, the Control Pad is wired to the Control Module by 3 wire (min. 20 gauge). Connect the colour coded terminals to the corresponding terminals on the Control Module. When the Control Pad is remotely mounted in the Ventilation Dehumidistat or Air Sentry, refer to optional controls page for wiring requirements.

Self Test

Each time the HRV/ERV is powered/energized the self test function will automatically initiate. During the self test the HRV/ERV will cycle through all the speeds available (1-5), test the damper motor operation and will default back to the previous mode/speed selection, (factory default is Speed 1). Total self test duration is approximately 1 min. 30 sec.

Automatic Defrost Operation (Not on all models)

The advanced technology of the digital microprocessor automatically activates the defrost system only as it is needed. To be an efficient heat recovery device, the HRV/ERV must effectively provide for core defrost as well as providing efficient heat exchange. As outdoor conditions cool, the temperature sensor (thermistor) tracks the supply air temperature. The thermistor then sends its signal to the microprocessor (circuit board) which initiates only the defrost cycle time required to clear the core. On recirculating defrost models, the core is defrosted when the supply air port is automatically blocked off and exhaust air is redirected back through the HRV/ERV. On damper defrost models, the core is defrosted when the supply air port is automatically blocked off and the warm air surrounding the HRV/ERV is drawn in through the defrost port. The mode indicator will flash RED during the defrost cycle. This dramatic advance makes more energy available for recovery as the unit spends less time in defrost mode. By optimizing the defrost cycle, the HRV/ERV combines money saving performance with a well designed and reliable control system.

Glossary

DEFROST MODE - to ensure reliable operation during cold weather, the HRV/ERV will automatically cycle through its defrost mode as needed. (not on all models)

DEHUMIDISTAT - a control device that senses the amount of moisture in the air and will activate high speed fan operation when the air moisture level exceeds the control setting. The optimum air moisture level (or relative humidity [Rh]) in the typical home is in the range of 30 to 40% Rh.

RESET - whenever resetting of the HRV/ERV is required, simply disconnect power for 30 seconds.

STANDBY MODE - the HRV/ERV is energized and waiting for fan operation to be initiated by a remote device or manual override.

THERMISTOR - the HRV/ERV's temperature sensor which measures electrical resistance in a known manner, as outdoor temperatures fluctuate.

To select mode of operation for ControlAir 15

Press and hold the fan selection button on the Control Pad. After 5 seconds the control will begin to cycle each mode holding each for 2 seconds. Release the button when the desired mode of operation is reached.

Modes of Operation

LED Indication

OFF

No LED's illuminated HRV/ERV is off, no controls will initiate operation.

Standby / On

Steady Green LED and Yellow LED to indicate speed
HRV/ERV will run at speed selected in ventilation mode. Standby mode is indicated by no speed indicator illuminated. Optional remote controls will override standby or selected speed into high speed.

20 On / 40 Off

Flashing Green LED and Yellow LED to indicate speed.
HRV/ERV will operate in ventilation mode at speed selected for 20 minutes and OFF for 40 minutes.

Recirculation

**Note: Not available on all models*

Steady Red LED and Yellow LED to indicate Speed.
HRV/ERV will operate in recirculate mode at the selected speed. Optional remote controls will override unit into high speed ventilate mode.

To select speed

Momentarily press fan selection button and release. HRV/ERV will move into next speed. OFF is indicated by no yellow LED illuminated. Speed 1 is the first yellow LED. Speed five is indicated by a flashing speed 4 LED.

Automatic Defrost

During cold outdoor conditions the HRV/ERV will occasionally go into an automatic defrost function, which will prevent ice from forming on the core. Defrost is indicated by a flashing Red LED indicator.

ControlAir 15

OPTIONAL REMOTE CONTROLS

PROGRAMMABLE VENTILATION CONTROLLER (PVC)

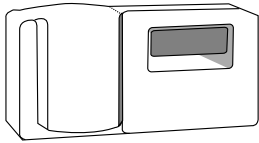

- LOCATION:** Hallway, kitchen, office & work place (connect 1/unit only)
- Advanced digital remote.
 - Digital dehumidistat.
 - Full fan speed control.
 - AIR SENTRY™ Air Quality Sensor built-in.
 - Recirculation mode (on compatible HRV/ERVs).
 - 7 day, 24 hour programmable timer.
 - Digital display and status lights.
 - 100' (30 m) maximum wire length.

PART NO. 99-105

Connects to **RED, ORANGE, GREEN** and **YELLOW** terminals.

***NOTE:** This device is **NOT** compatible with the Air Sentry.

NEW! AIR SENTRY™ AIR QUALITY SENSOR

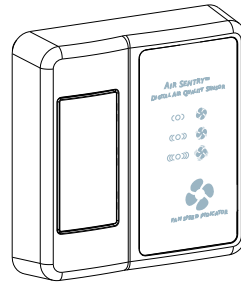

- LOCATION:** Kitchen, basement, work place (connect 1/unit only).
- Digital Air Quality Monitor.
 - Status light indicates fan speed.
 - Increases ventilation to remove odours and contaminants.
 - Among gases detected are cigarette smoke and formaldehyde.
 - 100' (30 m) maximum wire length.
 - Knockout designed to accept Control Pad when remotely mounted.

PART NO. 99-109

Connects to **RED, GREEN** and **YELLOW** terminals.

***NOTE:** This device is **NOT** compatible with the PVC.

NEW! VENTILATION DEHUMIDISTAT

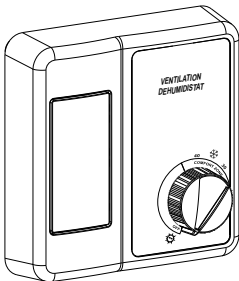

- LOCATION:** Central location in house.
- Dehumidistat activates high speed over-ride when humidity level in home exceeds setting.
 - Knockout designed to accept Control Pad when remotely mounted, giving full HRV/ERV functionality & control from remote location.

PART NO. 99-250

Connects to **BLACK, RED, GREEN** and **YELLOW** terminals.

*Replaces **99-116 DVC** & **99-230 VRD**.

*Only compatible with ControlAir 15 electronics.

DIGITAL ELECTRONIC TIMER (DET)

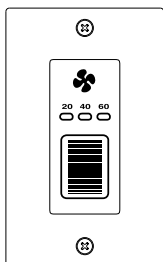

- LOCATION:** Bathrooms & kitchen
- Connect up to 8 on 300' (91 m) wire max.
 - If a PVC or Air Sentry is used, connect up to 5 on 300' wire max.
 - Touch pad operation.
 - 20/40/60 minute status lights.
 - Compact wall mount unit.
 - Mounts in 2x4 box.
 - Shown with "decora" cover plate (99-107W).

PART NO. 99-104

Connects to **RED, GREEN** and **YELLOW** terminals.

ControlAir 15

- All controls wire to matching colour on the Control Module.
- Control Pad can be removed and mounted in a remote location.
- Control Pad mounts in a 2" x 4" box or can be mounted in the optional Ventilation Dehumidistat or Air Sentry.
- Full fan speed control.
- Three Modes of Operation
 - Standby/ON
 - 20 ON / 40 OFF
 - Recirculation
 (on compatible HRV/ERVs)

***See individual control instructions for more details.**

USING THE DEHUMIDISTAT

Some models have a built-in dehumidistat (an optional remote wall mount dehumidistat can be installed, see Optional Remote Controls), to control harmful, excess humidity **during the heating season**. The dehumidistat operates in % of RH (relative humidity) with 80 being high and 20 being low. The average person is comfortable between 30-45%.

The dehumidistat will override the ventilator to high speed when the moisture level in the home

exceeds the set point on the control. Once the humidity in the house is reduced, the HRV/ERV will revert back to its previous setting. The dehumidistat should be set to off for all seasons except the heating season.

Note: *If your HRV/ERV is equipped with an internal and an external dehumidistat, the internal one can be turned off and not used.*

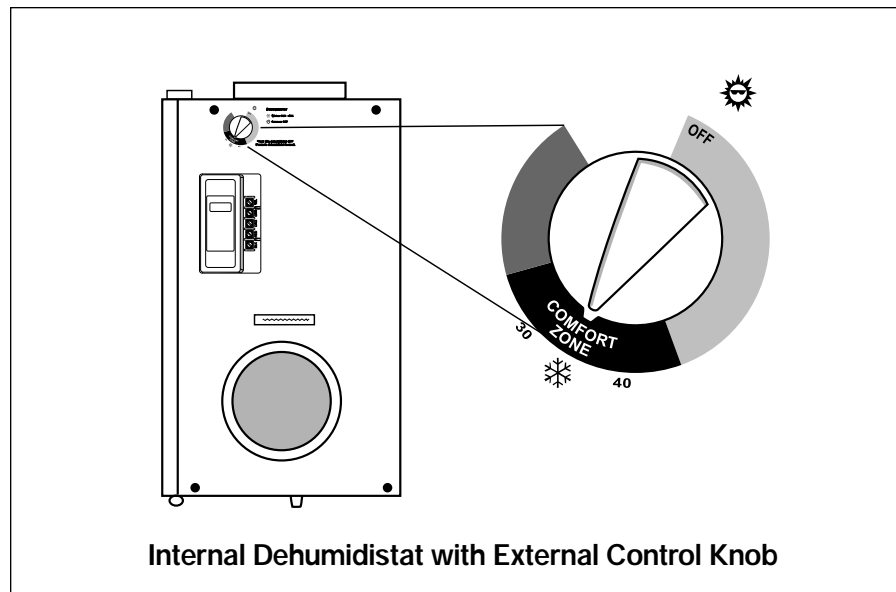

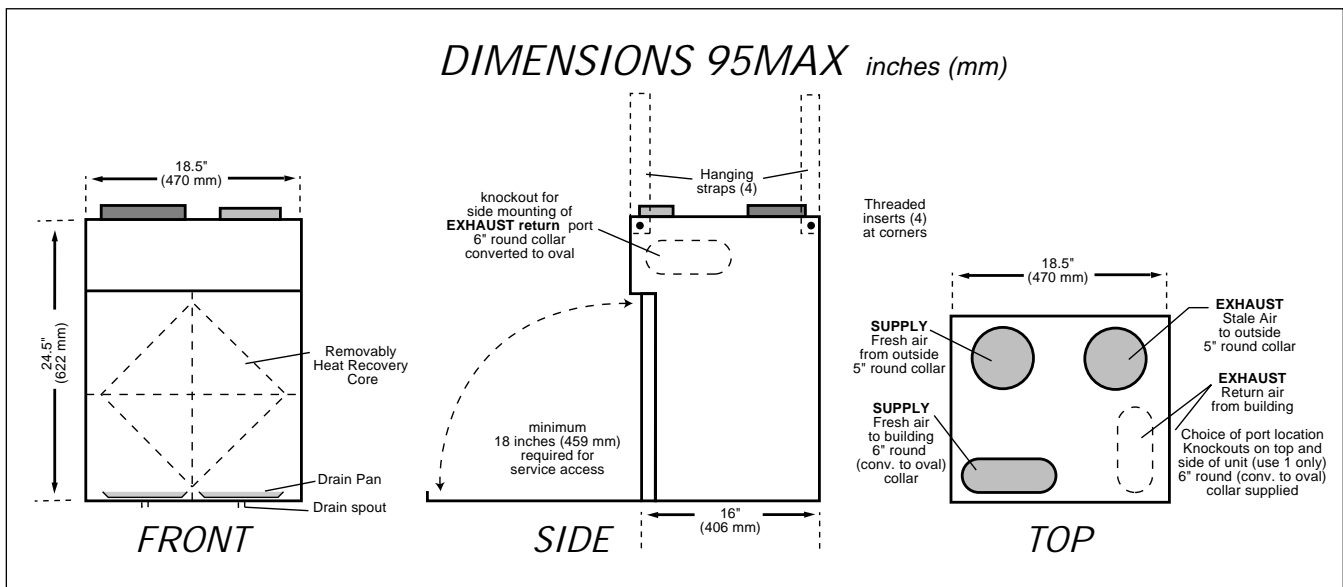

95 MAX Port Specifications

The 95 Max Heat Recovery Ventilator (HRV) has been designed to allow the installer to choose between two possible positions on the cabinet for the INDOOR EXHAUST (return from building) port. Illustrations in this manual show standard (side mounted) port location. The same specifications apply to both 95 Max setups, regardless of which port position is selected.

In order to make the 95 Max as space efficient as possible, the INDOOR supply and return ports are converted from round to oval shape. Overall size of the port remains the same. Simply bend a standard duct fitting to the correct shape, and attach to the oval port using the same method as for a round port.

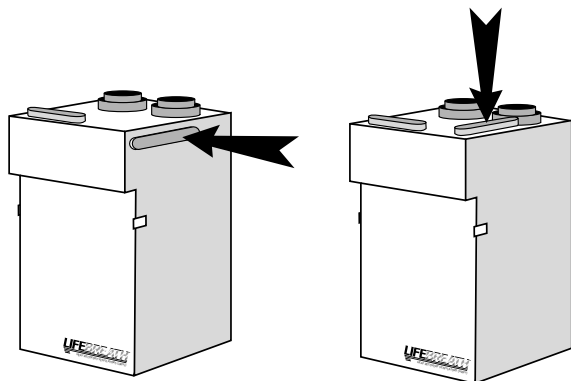

SIDE MOUNTED PORT
standard location

TOP MOUNTED PORT
alternate location

Variable Port Location

Variable Port Location / Installation (Model 95 Max only)
The exhaust return port collar is not factory installed. Installer may choose either **side mounted** or alternate **top mounted** port by simply removing one of the two knock-out plates and attaching a port collar (supplied). To remove knock-out plate, insert a utility knife into the knock-out slits and trace them completely to puncture protective film underneath. Then, cut the solid tabs between the slits, using tin snips or side cutters, and remove the knock-out plate. If any protective film still blocks the opening, **remove it now**.

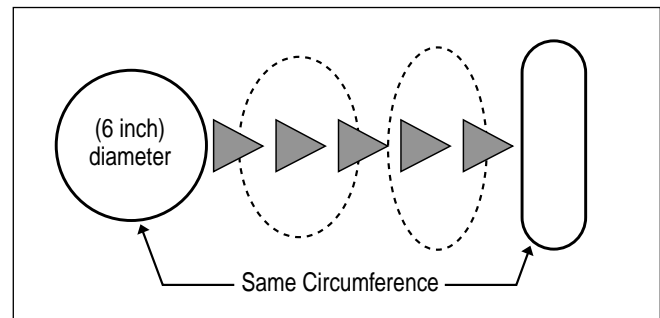

Round port bent to oval

95 MAX Air Flow

Stale air enters the FRONT RIGHT side port. The air will pass down the front half of the core, then up the back half of the core and out the RIGHT REAR port.

Fresh outdoor air will enter the LEFT REAR port and pass down the back half of the core. It will then pass up the front half of the core, and out the LEFT FRONT port. This unique configuration allows the air to actually travel through the core twice, making the 95 MAX almost as efficient as a double core unit.

INSTALLATION

Location

The HRV/ERV must be located in a heated space where it will be possible to conveniently service the unit. Typically the HRV/ERV would be located in the mechanical room or an area close to the outside wall where the weatherhoods will be mounted. If a basement area is not convenient or does not exist, a utility or laundry room may be used.

Attic installations are not normally recommended due to:

- A) the complexity of work to install
- B) freezing conditions in the attic
- C) difficulty of access for service and cleaning

Sufficient clearance at the front of the access door is required for servicing the air filters and core. A minimum of 25" (635 mm) clearance is recommended so the door can be opened. Four PVC reinforced polyester hanging straps are provided for hanging the HRV/ERV from the basement floor joists.

Mounting

The hanging straps should be attached to the unit at the top end corners (mounting screws are already located on the HRV/ERV case). Securely fasten the other end of the straps to the floor joists with wide head nails (not supplied), making sure the **unit is level**. The straps are designed to reduce the possibility of noise, resonance or harmonics; therefore using the full length of the strap between the HRV/ERV and the floor joists is recommended.

Electrical

The HRV/ERV should be plugged into a standard designated (120VAC) electrical outlet with ground. It is not recommended that an extension cord be used for this appliance. If further wiring is required, then a licensed electrician should make all electrical connections. It is recommended that a separate 15 amp/120 volt circuit be used.

WARNING:

In order to prevent electric shock when cleaning or servicing the HRV/ERV, it is extremely important to confirm the polarity of the power line that is switched by the safety (disconnect) switch. The hot line (black) is the proper line to be switched. To confirm the proper polarity, use a voltmeter or test lamp to ensure there is no power after the switch when the door is open. Check between that point and ground (on the cabinet). This must be done as dwellings are occasionally wired improperly. Always make sure that the HRV/ERV is properly grounded.

Connecting Appliances to the HRV/ERV

It is **not** recommended that any of the following appliances be connected to the HRV/ERV:

- clothes dryer
- range top
- stovetop fan
- central vacuum system

Lint, dust or grease will collect in the HRV/ERV, damaging the unit.

NOTE: Connecting any of these to the HRV/ERV will invalidate your warranty.

Installing the Drain Line and P-Trap (not on all models)

When defrosting, the HRV/ERV may produce some condensation. This water should flow into a nearby drain, or be taken away by a condensate pump. The HRV/ERV and all condensate lines must be installed in a space where the temperature is maintained above the freezing point.

At the bottom of the cabinet there are pre-punched holes for the drain pan connectors (see below). Insert the drain spout through the hole in the drain pan. Do not forget the "O Ring" which seals the connector to the pan. **REMEMBER TO HAND TIGHTEN ONLY** the washer and lock nut which hold the drain connector in place.

Construct a P-Trap using the plastic tee connector. Cut two lengths of hose and connect each piece to an end of the "T" fitting, then connect the other ends to the two drain spouts. Allow the "T" fitting to point upwards, and connect the drain line. Tape or fasten base to avoid any kinks. This creates a "trap" which will hold some condensate and prevent odours from being drawn up the hose and into the fresh air supply of the HRV/ERV.

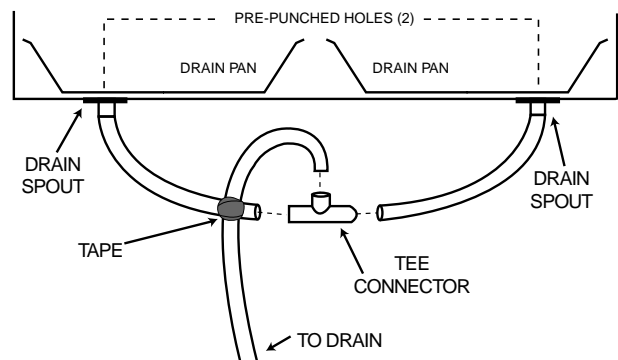

Forming the "P" Trap

INSTALLING AIR DUCTS

A well designed and installed ducting system will allow the HRV/ERV to operate at its maximum efficiency.

Always try to keep duct runs as short and straight as possible. See *Installation Diagrams* for various installation options.

Outside Weatherhoods

The fixed covered hoods have a built-in bird screen with a 1/4" (6 mm) mesh to prevent foreign objects from entering the ductwork.

Locating the Intake Weatherhood

- Should be located upstream (if there are prevailing winds) from the exhaust outlet
- At least 6' (2 m) from the exhaust weatherhood
- At least 6' (2 m) away from dryer vents and furnace exhaust (medium or high efficiency furnaces)
- A minimum of at least 6' (2 m) from driveways, oil fill pipes, gas meters, or garbage containers
- At least 18" (457 mm) above the ground, or above the depth of expected snow accumulation
- At least 3' (1 m) from the corner of the building
- Do not locate in a garage, attic or crawl space

Locating the Exhaust Weatherhood

- At least 6' (2 m) from the ventilation air intake
- At least 18" (457 mm) above ground or above the depth of expected snow accumulation
- At least 3' (1 m) away from the corner of the building
- Not near a gas meter, electric meter or a walkway where fog or ice could create a hazard
- Not into a garage, workshop or other unheated space

When installing the weatherhood, its outside perimeter **must** be sealed with exterior caulking.

Installing the ducting from the weatherhoods to the HRV/ERV

The inner and outer liners of the flexible insulated duct must be clamped to the sleeve of the weatherhoods (as close to the outside as possible) and the appropriate port on the HRV/ERV. It is very important that the fresh air intake line be given special attention to make sure it is well sealed. A good bead of high quality caulking (preferably acoustical sealant) will seal the inner flexible duct to both the HRV/ERV port and the weatherhood prior to clamping.

To minimize air flow restriction, the flexible insulated duct that connects the two outside weatherhoods to the HRV/ERV should be stretched tightly and be as short as possible.

Twisting or folding the duct will severely restrict air flow. See below for the recommended connection of flexible insulated ducts to the the outside weatherhoods and the HRV/ERV.

WEATHERHOOD INSTALLATION

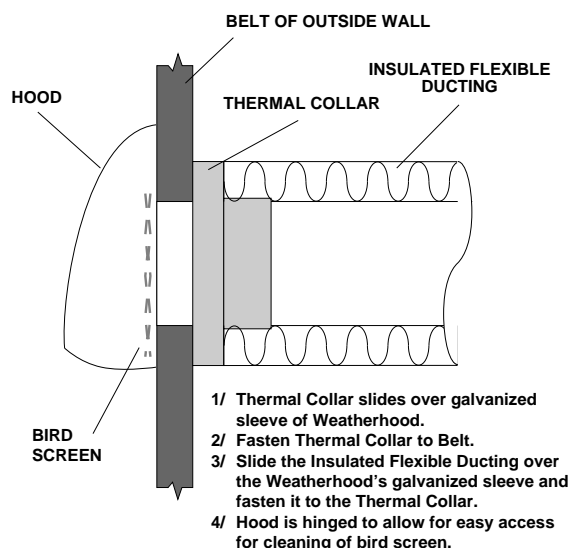

Warmside Ducting

To maximize airflow in the ductwork system, all ducts should be kept short and have as few bends or elbows as possible. Forty-five degree elbows are preferred to 90° elbows. Use "Y" tees instead of 90° elbows whenever possible.

All duct joints must be fastened with screws, rivets or duct sealant and wrapped with a quality duct tape to prevent leakage. We recommend aluminum foil duct tape.

Galvanized ducting from the HRV/ERV to the living areas in the house is recommended whenever possible, although flexible duct can be used in moderation if necessary.

To avoid possible noise transfer through the ductwork system, a short length (approximately 12" or 300 mm) of non-metallic flexible insulated duct should be connected between the HRV/ERV and the supply/ exhaust ductwork system.

The main supply and return lines to/from the HRV/ERV must be 6 inches (150 mm) minimum. Branch lines to the individual rooms may be as small as 4 inches (100 mm), but 5 inch (125 mm) lines are preferred .

All ducts running through attics and unheated spaces must be sealed and insulated to code.

SUPPLY AIR DUCTING

In homes without a forced air furnace, fresh air should be supplied to all bedrooms and living areas, excluding bathrooms, kitchen and utility areas. It should be supplied from high wall or ceiling locations. Grilles that diffuse the air comfortably such as the Techgrille™ are recommended.

If the floor is the only option available, then special care should be taken in locating grilles. Areas such as under baseboard heaters will help to temper the air. Also optional inline duct heaters are available for mounting in the supply duct work to add heat if required.

In homes with a forced air furnace, you may want to connect the HRV/ERV to the furnace ductwork (see information below).

Direct Connection to Furnace Ductwork

Should you wish to hard duct the supply air directly into the cold air return of the furnace, remember to check the air flow balance of the HRV/ERV with the furnace fan both "ON" and "OFF" to determine that it does not imbalance the unit more than 10%. Also, it is advisable to include a short length of fabric flex duct or other non-metallic connector in this hard ducted line in order to keep the HRV/ERV separately grounded (electrically) from the furnace. This will avoid a possible shock hazard to service people if a short to ground develops in one of the devices.

Indirect Connection to Ductwork

If permitted by local codes, an indirect connection may be made between the HRV/ERV supply duct and the furnace return plenum. The fresh air from the unit may be directed at a grille installed in the cold air return duct of the furnace. The fresh air supply outlet from the unit should be no closer than 4 inches (100 mm) and no more than 12 inches (300 mm) from the grille.

Stale Air Exhaust System

The stale air exhaust system is used to draw air from the points in the house where the worst air quality problems occur. It is recommended that return air ducts are installed in the bathroom, kitchen, and laundry room. Additional return air ducts from strategic locations (i.e. greenhouse, atrium, swimming pool, sauna, etc.) may be installed. Also, the furnace return duct may be used to exhaust from. In this method, the exhaust air is not ducted back to the HRV/ERV with "dedicated lines" from bathrooms, kitchens, etc. Instead, the exhaust air is drawn out of the cold air return of the forced air furnace. This method has become popular and provides good ventilation when installed in accordance with the instructions. **The furnace blower must be running when the unit is operating for this system to be effective.**

Dampers and Grilles

The use of balancing dampers and/or adjustable grilles to balance the flow rates into various rooms is recommended. We suggest TECHGRILLE™ air diffusers.

- The TECHGRILLE™ is available in 4", 5", 6" and 8" (100, 125, 150 and 200 mm) sizes.
- The TECHGRILLE™ is a round, fully adjustable grille, which provides superior, quiet air distribution.

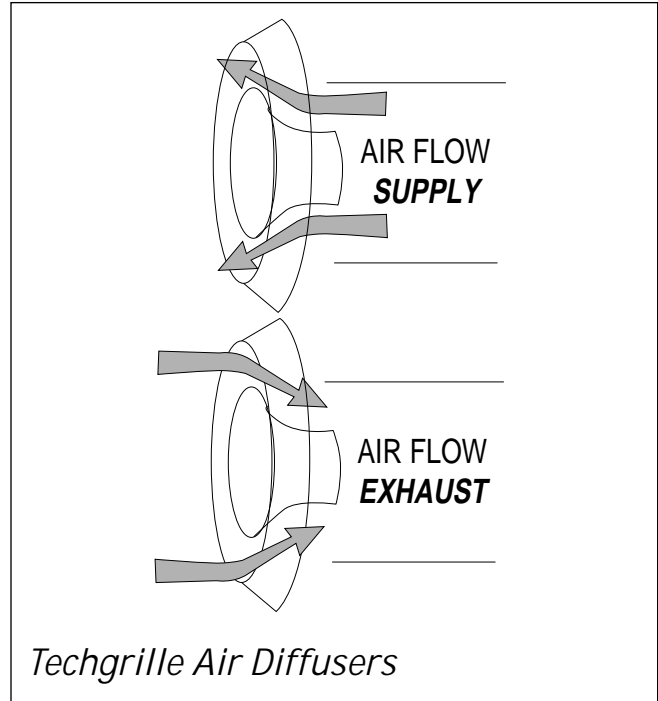

We recommend the use of high mounted wall returns with grilles. The exhaust air duct from the kitchen should never be connected to a range hood. Instead, the exhaust grille should be mounted high on the wall at least 4 feet (1.2 m) horizontally away from the stove. A "flip-up", 6" X 10" (150 X 250 mm) rectangular kitchen grille with removable grease filter is available (Part No. 10-002).

Dampers should be located just prior to the HRV/ERV to balance the stale air exhausted out of the house with a fresh air supply entering the house.

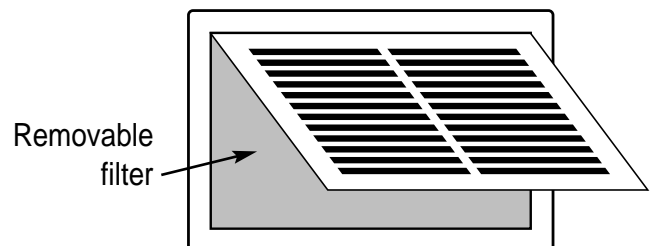

Kitchen Grille

Installation Diagrams

Example diagram only - duct configuration may change depending on model

Partially Dedicated System

- Stale air drawn from key areas of home (bathroom, kitchen, laundry)
- Fresh air supplied to return air duct of furnace
- HRV/ERV must be balanced

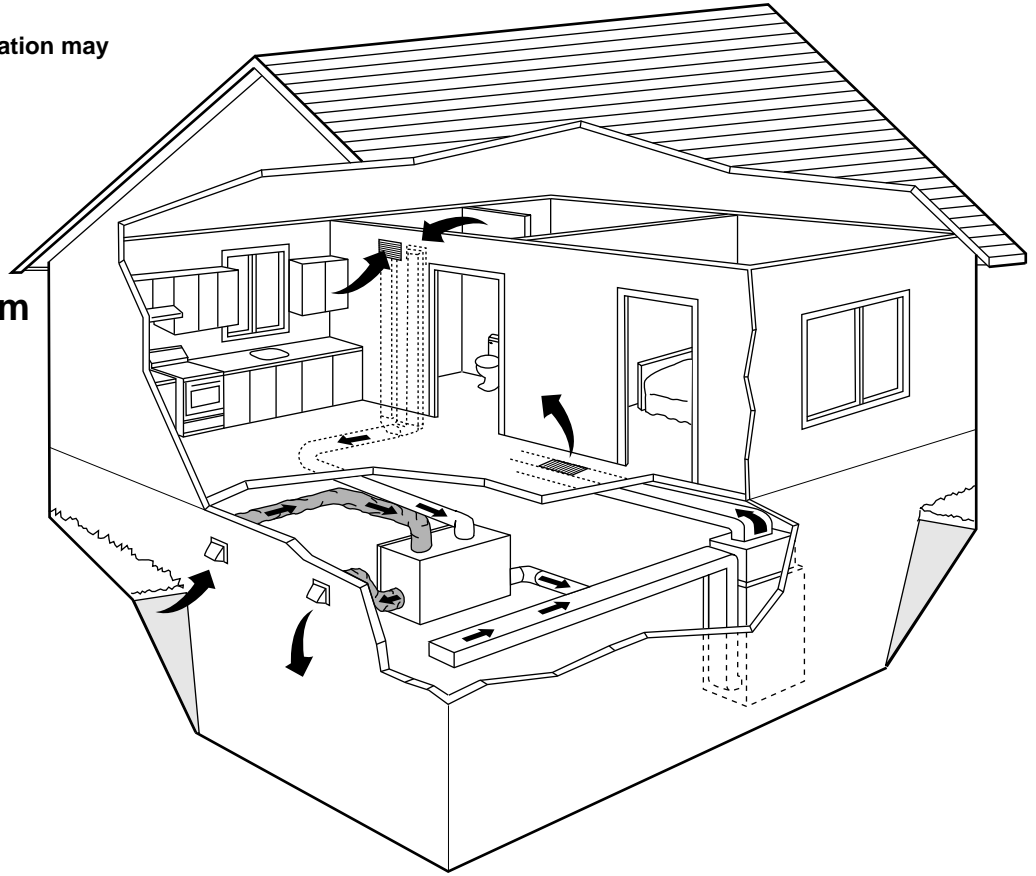

DIRECT CONNECTION of the SUPPLY AIR STREAM to the FURNACE COLD AIR RETURN (Stale air drawn from key areas of home)

EXHAUST AIR from various parts of home.
i.e. bathrooms (if required), kitchens (if required).

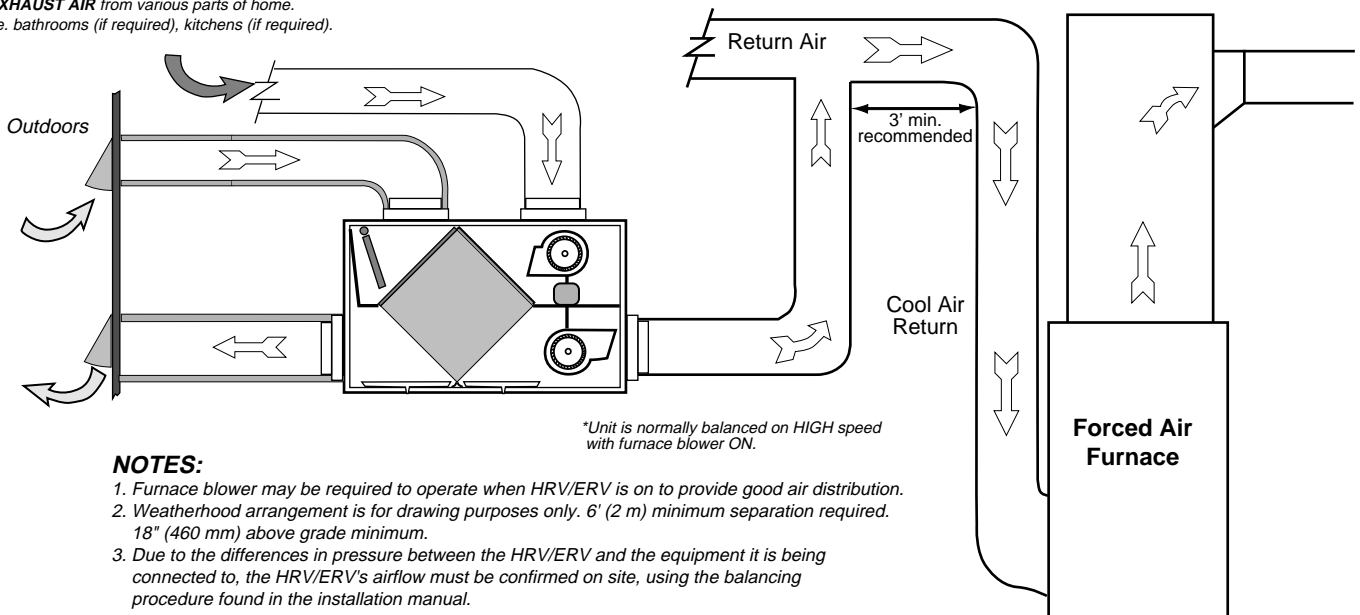

Example diagram only - duct configuration may change depending on model

Simplified Installation

Option 1 (Return/Return Method)

- HRV/ERV must be balanced
- It is mandatory that the furnace blower run continuously or HRV/ERV operation be interlocked with the furnace blower
- Check local codes / authority having jurisdiction for acceptance

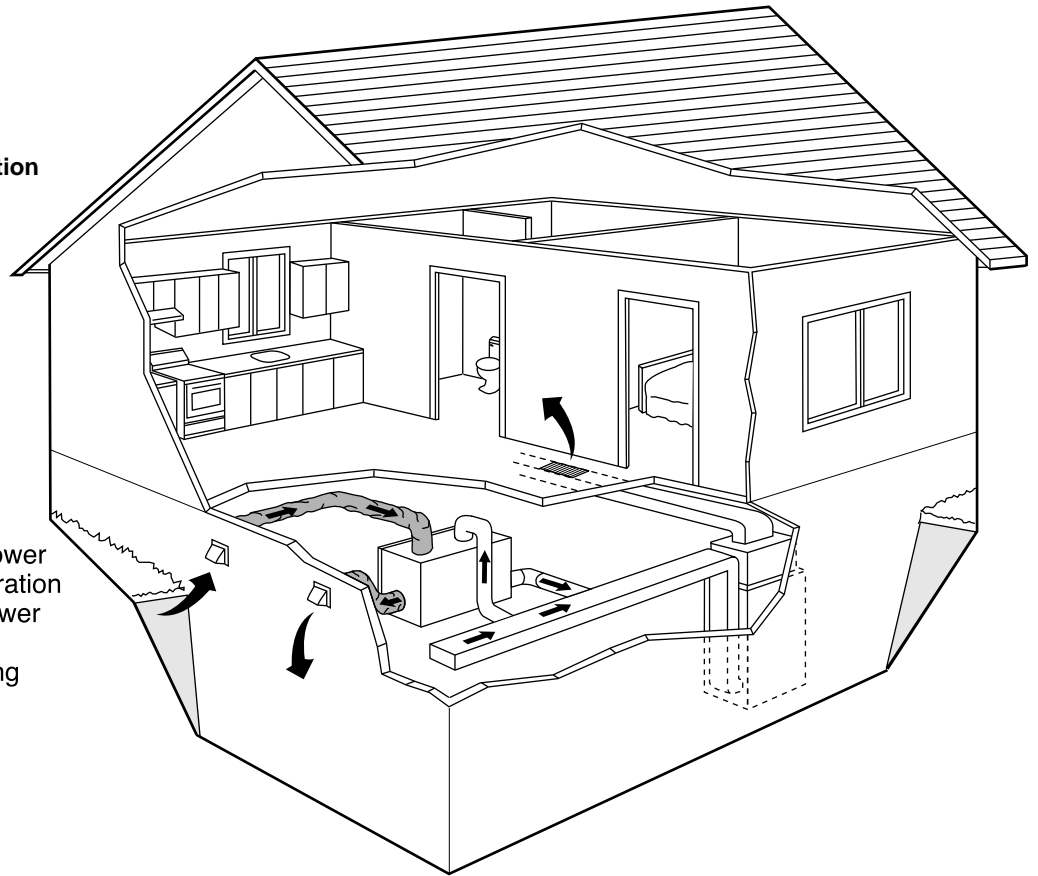

Note: Option 1 is the preferred / recommended method when doing a simplified installation.

DIRECT CONNECTION of both the HRV/ERV SUPPLY AIR STREAM and EXHAUST AIR STREAM to the FURNACE COLD AIR RETURN

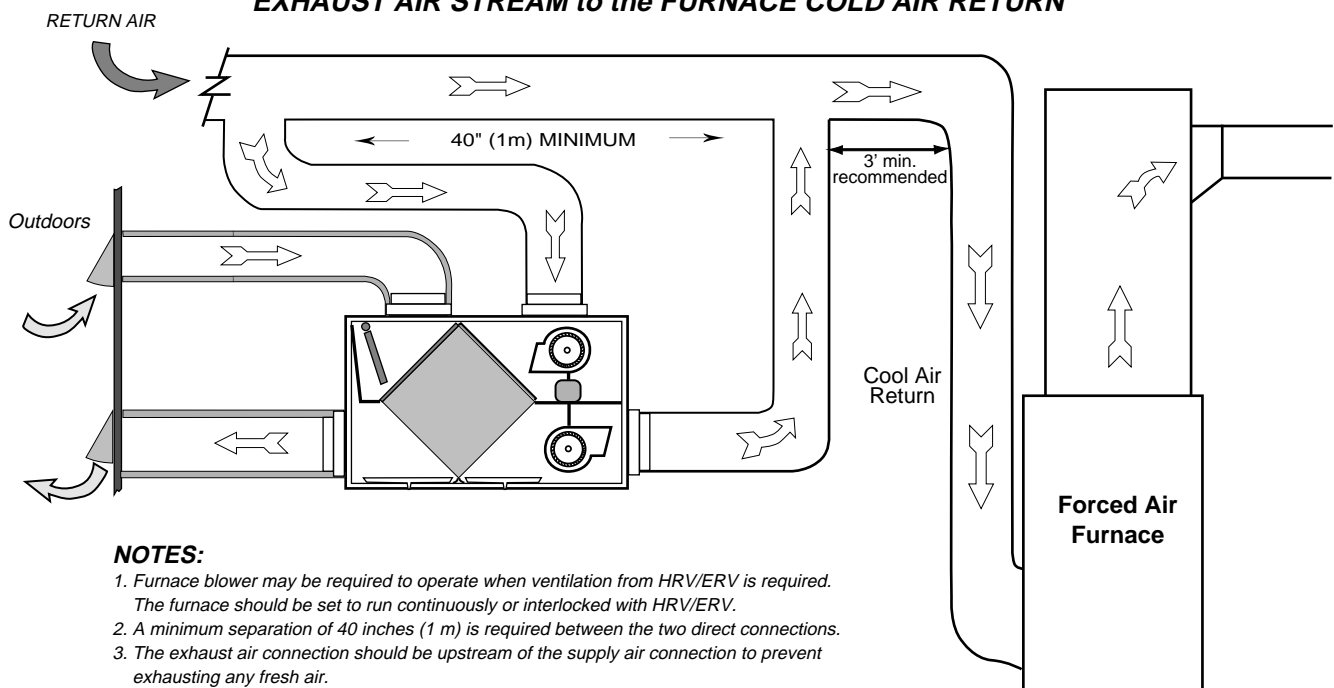

NOTES:

1. Furnace blower may be required to operate when ventilation from HRV/ERV is required. The furnace should be set to run continuously or interlocked with HRV/ERV.
2. A minimum separation of 40 inches (1 m) is required between the two direct connections.
3. The exhaust air connection should be upstream of the supply air connection to prevent exhausting any fresh air.
4. Weatherhood arrangement is for drawing purposes only. Six feet (2 m) minimum separation required. Eighteen inches (460 mm) above grade minimum.
5. Due to the differences in pressure between the HRV/ERV and the equipment it is being connected to, the HRV/ERV's airflow must be confirmed on site, using the balancing procedure found in the installation manual.

**Unit is normally balanced on HIGH speed with furnace blower ON.*

Example diagram only - duct configuration may change depending on model

Simplified Installation

Option 2 (Supply/Return Method)

- HRV/ERV must be balanced
- It is recommended that furnace blower run continuously or HRV/ERV operation be interlocked with the furnace blower
- Check local codes / authority having jurisdiction for acceptance

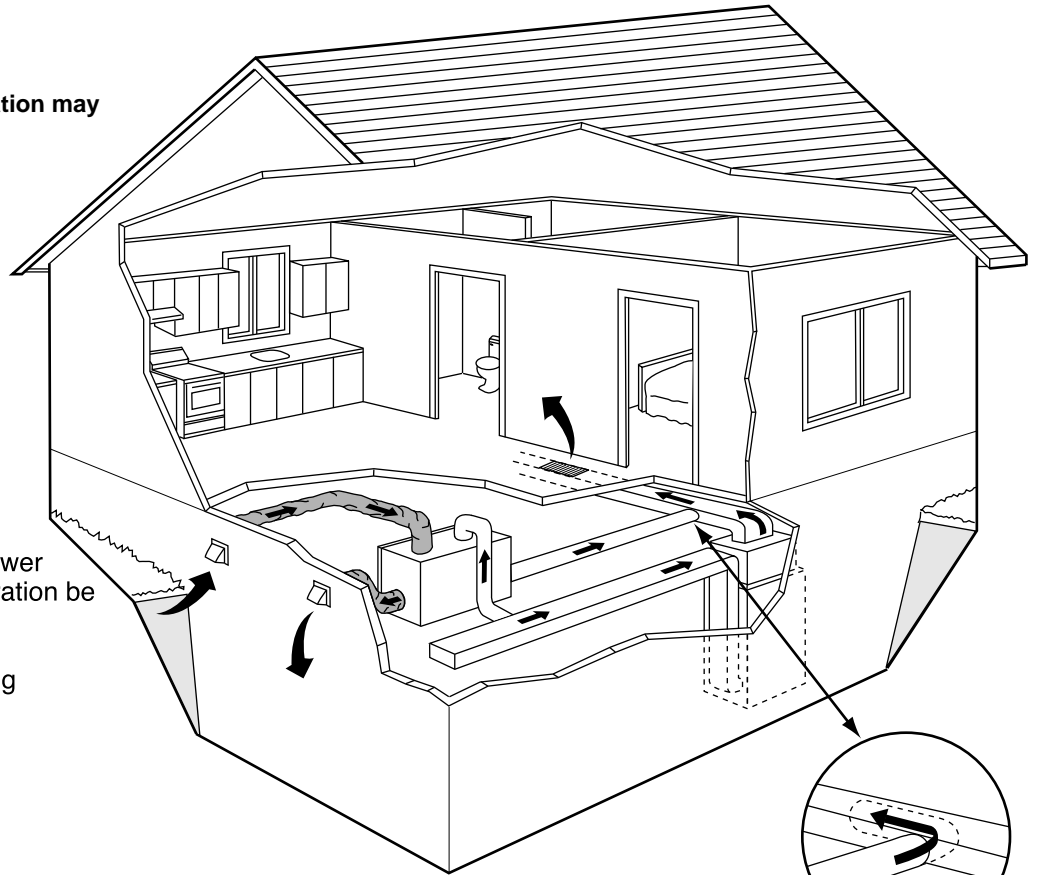

It may be necessary to form an elbow in the supply side ducting as shown

DIRECT CONNECTION of both the HRV/ERV SUPPLY AIR STREAM and EXHAUST AIR STREAM to the FURNACE COLD AIR RETURN & SUPPLY AIR SIDE

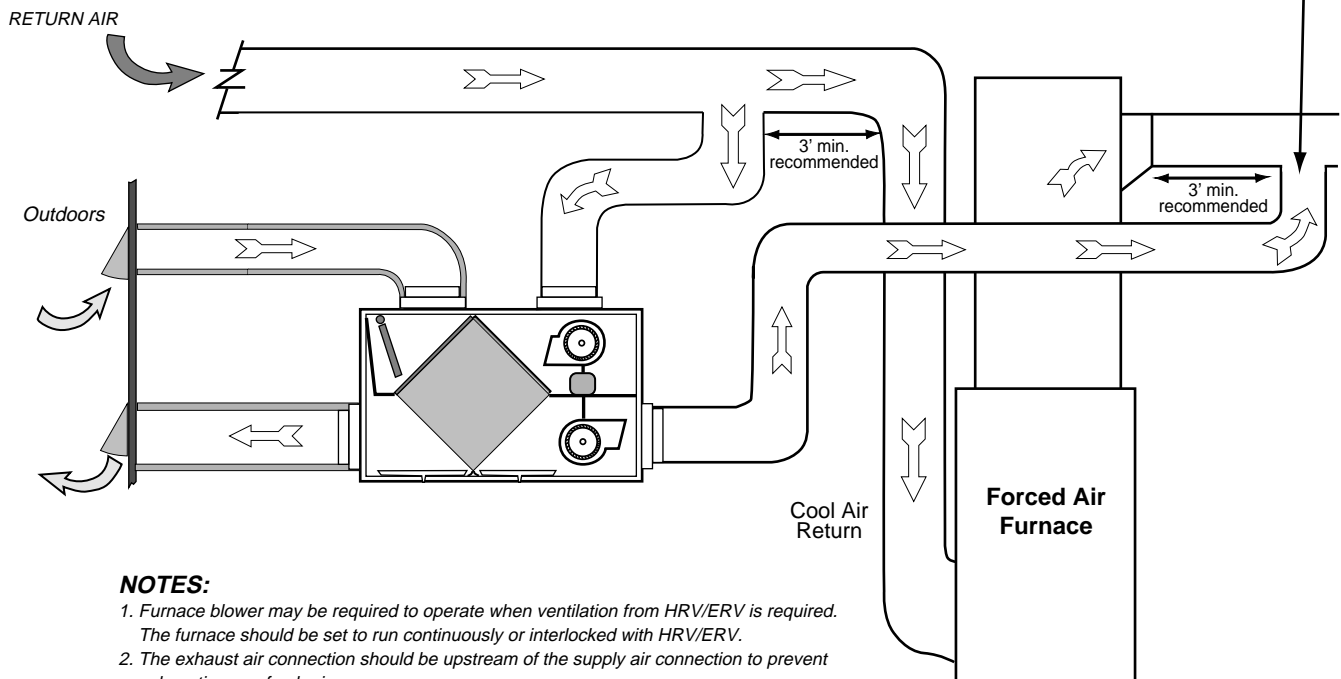

NOTES:

1. Furnace blower may be required to operate when ventilation from HRV/ERV is required. The furnace should be set to run continuously or interlocked with HRV/ERV.
2. The exhaust air connection should be upstream of the supply air connection to prevent exhausting any fresh air.
3. Weatherhood arrangement is for drawing purposes only. Six feet (2 m) minimum separation required. Eighteen inches (460 mm) above grade minimum.
4. Due to the differences in pressure between the HRV/ERV and the equipment it is being connected to, the HRV/ERV's airflow must be confirmed on site, using the balancing procedure found in the installation manual.

Example diagram only - duct configuration may change depending on model

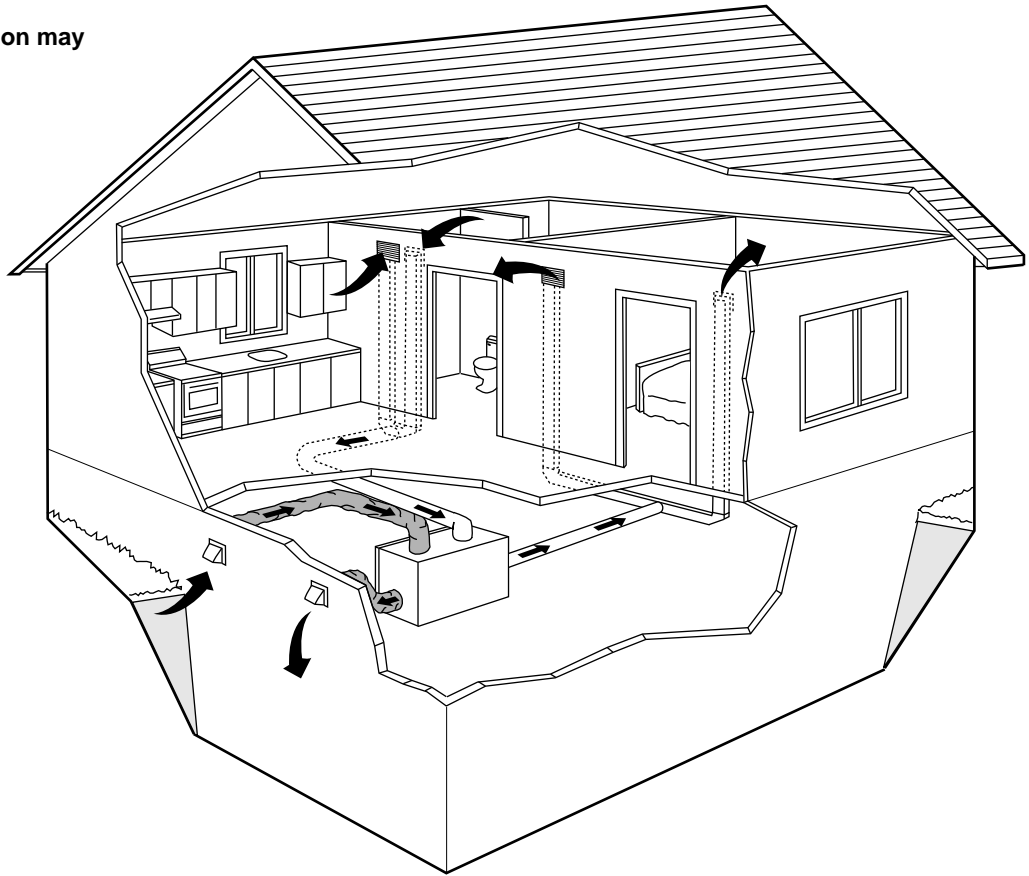

Fully Dedicated System

- Stale air drawn from key areas of home (bathroom, kitchen, laundry)
- Fresh air supplied to main living areas
- HRV/ERV must be balanced

Please Note: It is the responsibility of the installer to ensure all ductwork is sized and installed as designed to ensure the system will perform as intended. All air movement devices have a performance curve. The amount of air (CFM) that an HRV/ERV will deliver is directly related to the total external static pressure (E.S.P.) of the system. Static pressure is a measure of resistance imposed on the blower by length of duct work/number of fittings used in duct work, duct heater etc.

PITOT TUBE AIR FLOW BALANCING

It is necessary to have balanced air flows in an HRV/ERV. The volume of air brought in from the outside must equal the volume of air exhausted by the unit. If the air flows are not properly balanced, then;

- The HRV/ERV may not operate at its maximum efficiency
- A negative or positive air pressure may occur in the house
- The unit may not defrost properly
- Failure to balance HRV/ERV properly may void warranty

Excessive positive pressure may drive moist indoor air into the external walls of the building where it may condense (in cold weather) and degrade structural components. May also cause key holes to freeze up.

Excessive negative pressure may have several undesirable effects. In some geographic locations, soil gases such as methane and radon gas may be drawn into the home through basement/ground contact areas. Excessive negative pressure may also cause the backdrafting of vented combustion equipment.

Read the Application Warning on the front of this manual!

Prior to balancing, ensure that:

1. All sealing of the ductwork system has been completed.
2. All of the HRV/ERV's components are in place and functioning properly.
3. Balancing dampers are fully open.
4. Unit is on HIGH speed.
5. Air flows in branch lines to specific areas of the house should be adjusted first prior to balancing the unit. A smoke pencil used at the grilles is a good indicator of each branch line's relative air flow.
6. After taking readings of both the stale air to the HRV/ERV duct and fresh air to the house duct, the duct with the lower CFM ([L/s] velocity) reading should be left alone, while the duct with the higher reading should be dampered back to match the lower reading.
7. Return unit to appropriate fan speed for normal operation

BALANCING PROCEDURE

The following is a method of field balancing an HRV/ERV using a Pitot tube, advantageous in situations when flow stations are not installed in the ductwork. Procedure should be performed with the HRV/ERV on high speed.

The first step is to operate **all** mechanical systems on high speed, which have an influence on the ventilation system, i.e. the HRV/ERV itself and the forced air furnace or air handler if applicable. This will provide the maximum pressure that the HRV/ERV will need to overcome, and allow for a more accurate balance of the unit.

Drill a small hole in the duct (about 3/16"), three feet downstream of any elbows or bends, and one foot upstream of any elbows or bends. These are recommended distances but the actual installation may limit the amount of straight duct.

The Pitot tube should be connected to a magnehelic gauge or other manometer capable of reading from 0 to 0.25 in. (0-62 Pa) of water, preferably to 3 digits of resolution. The tube coming out of the top of the pitot is connected to the high pressure side of the gauge. The tube coming out of the side of the pitot is connected to the low pressure or reference side of the gauge.

Insert the Pitot tube into the duct; pointing the tip into the airflow.

For general balancing it is sufficient to move the pitot tube around in the duct and take an average or typical reading. Repeat this procedure in the other (supply or return) duct. Determine which duct has the highest airflow (highest reading on the gauge). Then damper that airflow back to match the lower reading from the other duct. The flows should now be balanced. Actual airflow can be determined from the gauge reading. The value read on the gauge is called the velocity pressure. The Pitot tube comes with a chart that will give the air flow velocity based on the velocity pressure indicated by the gauge. This velocity will be in either feet per minute or metres per second. To determine the actual airflow, the velocity is multiplied by the cross sectional area of the duct being measured.

This is an example for determining the airflow in a 6" duct. The Pitot tube reading was 0.025 inches of water. From the chart, this is 640 feet per minute.

The 6" duct has a cross sectional area of $= [3.14 \times (6" \div 12)^2] \div 4$
= 0.2 square feet

The airflow is then:
640 ft./min. X 0.2 square feet = 128 cfm

For your convenience, the cross sectional area of some common round duct is listed below:

DUCT DIAM. (inches)	CROSS SECTION AREA (sq. ft.)
5	0.14
6	0.20
7	0.27

The accuracy of the air flow reading will be affected by how close to any elbows or bends the readings are taken. Accuracy can be increased by taking an average of multiple readings as outlined in the literature supplied with the Pitot tube.

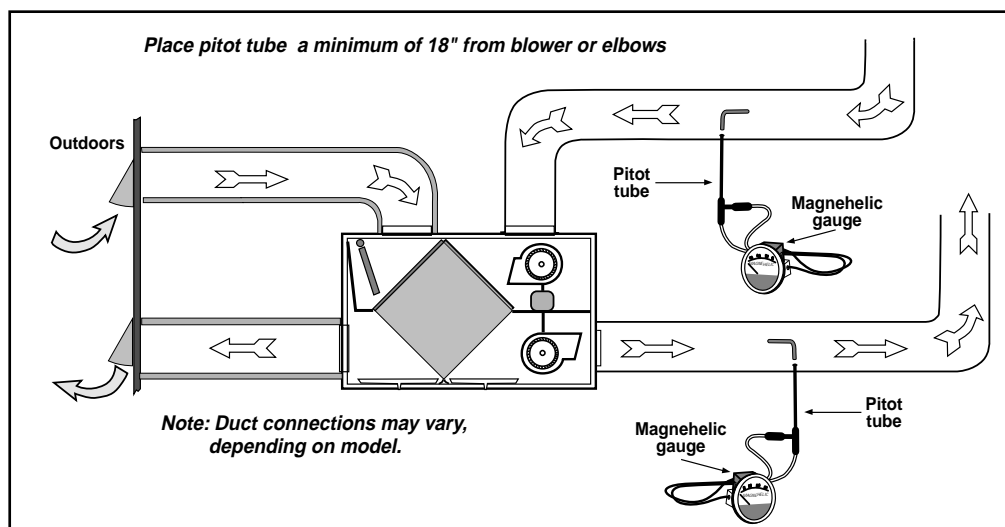
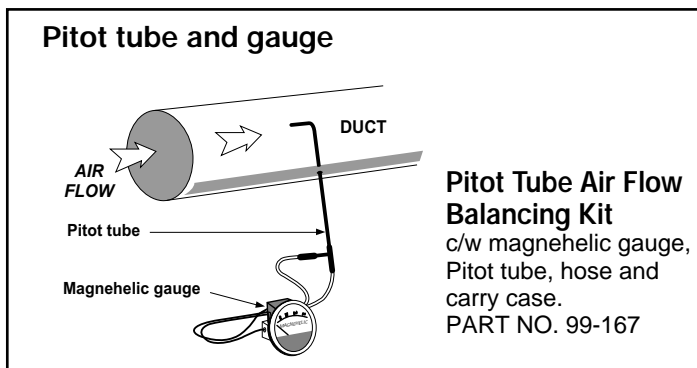

BALANCING COLLAR INSTRUCTIONS

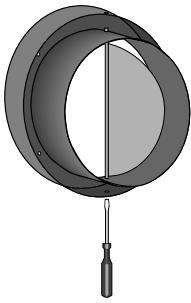

Push and turn with slotted screwdriver. Damper automatically locks when pressure is released.

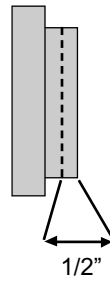
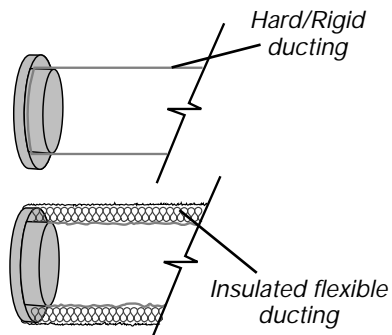

When connecting ductwork to the collar, take note where screws are located. Screws should be located no further than 1/2" from outside edge of collar, so as not to impede operation of the damper.

Installations where the HRV is ducted directly to the return of a furnace may require additional dampening on the *fresh air to building* duct. This is due to the high return static pressures found in some furnace installations.

Maintenance Routine for HRV (for ERV, see following page)

1. Inspect Exterior Hoods at least once a month.

Make sure exhaust and fresh air supply hoods are not blocked or restricted by leaves, grass, or snow. In winter, it is especially important to make sure snow is not blocking the hoods or that frost has not built up on the wire mesh (bird screen).

WARNING: Blockage of hoods may cause an imbalance.

2. Clean Air Filters (clean twice a year)

The standard filters equipped with your HRV are removable and washable.

- simply open access door and slide core out
- remove filter clips
- once clips are removed filters can be taken off the core to be rinsed with water or a combination of mild soap and water. Do not clean in the dishwasher
- to re-assemble, place clean filter(s) (wet or dry) back into their positions against the core and return clips to their original position
- slide core back into its' original position

3. Clean Core Twice a Year

- open access door.
- carefully grip ends of core and pull evenly outward. Core may be snug, but will slide out of the channel
- once removed from the cabinet remove filters
- wash core in warm soapy water (do not use dishwasher)
- install the clean filters
- install clean core

Note: Core installation label on the outer end of the core.

To install the clean core:

- first mount the bottom flange of the core guide into the bottom H channel approximately 1/4" (6mm)
- mount the left or right side flange of the core guide approximately 1/4" (6mm) followed by the other side
- mount the top flange of the core guide into the top H channel approximately 1/4" (6mm).
- with all four corners in place and the core straight and even, push hard in the centre of the core until the core stops on the back of the cabinet.

NOTE: Core will appear to stick out from cabinet approximately 1/8" (3mm). This is designed this way so that the access door will fit tight against the core.

4. Motors - Maintenance Free

5. Drain (condensate) Line - Clean once a year

Inspect drain line, drain spout and "P" trap for blockage, mould or kinks. Flush with warm soapy water and replace if worn, bent or unable to clean.

6. Clean Duct Work if Required

The duct work running to and from the HRV may accumulate dirt. Wipe and vacuum the duct once every year. You may wish to contact a Heating/Ventilation company to do this.

7. General Maintenance - Twice a Year

Wipe down the inside of the cabinet with a damp cloth to remove dirt, bugs and debris that may be present.

8. Cleaning the Fans

Fans may accumulate dirt causing an imbalance and/or excessive vibration of the HRV. A reduction in the air flow may also occur. In new construction this may result within the first year due to heavy dust and may occur periodically after that over time depending on the outdoor conditions.

- unplug the HRV and open the service door
- remove the core
- remove ducting (metal and/or flexible insulated type) from the red and/or blue ports which are connected immediately inline with the fan assembly
- use a small brush, such as an old toothbrush or pipe cleaner, and insert first
 - through the large opening of the fan assembly and then
 - through the smaller opening in the end of the fan assembly.
- scrub individual fan blades until clean. **Avoid** moving or damaging balancing flat weight, clip is usually found on one or more of the fan blades
- vacuum and wipe
- reassemble making sure ducting is reattached firmly and insulation and moisture barrier are sealed and taped

Before attempting this task, thought should be given to having a qualified service technician complete the service work.

Maintenance Routine for ERV (for HRV, see previous page)

1. Inspect Exterior Hoods at least once a month

Make sure exhaust and fresh air supply hoods are not blocked up or restricted by leaves, grass, or dirt.

WARNING: Blockage of hoods may cause an imbalance.

2. Clean Air Filters Four Times a Year

The standard filters equipped with your ERV are removable and washable.

- a) simply open access door and slide core out
- b) remove filter clips.
- c) once clips are removed filters can be taken off the core to be rinsed with water or a combination of soap and water.
- d) to assemble, place clean dry filters back into their positions.
- e) install core to its original position

3. Clean Core Twice a Year

- a) open access door
- b) carefully grip ends of core and pull evenly outward
Core may be snug, but will slide out of the channel
- c) once removed from the cabinet remove filters
- d) **vacuum core to remove dust from core surface.**

DO NOT WASH!!

- e) install the clean, dry filters
- f) install clean core

NOTE: Core installation label on the outer end of the core.

To install the clean core:

- a) first mount the bottom flange of the core guide into the bottom H channel approximately 1/4" (6 mm)
- b) mount the left or right side flange of the core guide approximately 1/4" (6 mm) followed by the other side
- c) mount the top flange of the core guide into the top H channel approximately 1/4" (6 mm)
- d) with all four corners in place and the core straight and even, push hard in the center of the core until the core stops on the back of the cabinet.

NOTE: Core will appear to stick out from cabinet approximately 1/8" (3 mm). This is designed this way so that the access door will fit tight against the core.

4. Motors - MAINTENANCE FREE

5. Clean Duct Work if Required

The duct work running to and from the ERV may accumulate dirt. Wipe and vacuum the duct once every year. You may wish to contact a Heating/Ventilation company to do this.

6. General Maintenance - Twice a Year

Wipe down the inside of the cabinet with a damp cloth to remove dirt, bugs and debris that may be present.

7. Cleaning the Fans

Fans may accumulate dirt causing an imbalance and/or excessive vibration of the ERV. A reduction in the air flow may also occur. In new construction this may result within the first year due to heavy dust and may occur periodically after that over time depending on the outdoor conditions.

- unplug the ERV and open the service door
- remove the core
- remove ducting (metal and/or flexible insulated type) from the red and/or blue ports which are connected immediately inline with the fan assembly
- use a small brush, such as an old toothbrush or pipe cleaner, and insert first
 - (a) through the large opening of the fan assembly and then
 - (b) through the smaller opening in the end of the fan assembly.
- scrub individual fan blades until clean. **Avoid** moving or damaging balancing flat weight, clip is usually found on one or more of the fan blades
- vacuum and wipe
- reassemble making sure ducting is reattached firmly and insulation and moisture barrier are sealed and taped

Before attempting this task, thought should be given to having a qualified service technician complete the service work.

TROUBLESHOOTING YOUR HRV/ERV SYSTEM

SYMPTOM

CAUSE

SOLUTION

Poor Air Flows

- 1/4" (6 mm) mesh on the outside hoods is plugged
- filters plugged
- core obstructed
- house grilles closed or blocked
- dampers are closed if installed
- poor power supply at site
- ductwork is restricting HRV/ERV
- improper speed control setting
- HRV/ERV airflow improperly balanced

- clean exterior hoods or vents
- remove and clean filter
- remove and clean core
- check and open grilles
- open and adjust dampers
- have electrician check supply voltage at house
- check duct installation
- increase the speed of the HRV/ERV
- have contractor balance HRV/ERV

Supply air feels cold

- poor location of supply grilles, the airflow may irritate the occupant
- outdoor temperature extremely cold

- locate the grilles high on the walls or under the baseboards, install ceiling mounted diffuser or grilles so as not to directly spill the supply air on the occupant (eg. over a sofa)
- turn down the HRV/ERV supply speed. A small duct heater (1kw) could be used to temper the supply air
- placement of furniture or closed doors is restricting the movement of air in the home
- if supply air is ducted into furnace return, the furnace fan may need to run continuously to distribute ventilation air comfortably

Dehumidistat is not Operating

- improper low voltage connection
- external low voltage is shortened out by a staple or nail
- check dehumidistat setting it may be ON OFF

- check that the correct terminals have been used
- check external wiring for a short
- set the dehumidistat at the desired setting

Humidity Levels are too High
Condensation is appearing on the windows

- dehumidistat is set too high
- HRV/ERV is undersized to handle a hot tub, indoor pool, etc.
- lifestyle of the occupants
- moisture coming into the home from an unvented or unheated crawl space
- moisture is remaining in the washroom and kitchen areas
- condensation seems to form in the spring and fall
- HRV/ERV is set at too low a speed

- set dehumidistat lower
- cover pools, hot tubs when they are not in use
- avoid hanging clothes to dry, storing wood and venting clothes dryer inside. Heating wood may have to be moved outside
- vent crawl space and place a vapour barrier on the floor of the crawl space
- ducts from the washroom should be sized to remove moist air as effectively as possible, use of a bathroom fan for short periods will remove additional moisture
- on humid days, as the seasons change, some condensation may appear but the homes air quality will remain high with some HRV/ERV use
- increase speed of the HRV/ERV

Humidity Levels are too Low

- dehumidistat control set too low
- blower speed of HRV/ERV is too high
- lifestyle of occupants
- HRV/ERV air flows may be improperly balanced

- set dehumidistat higher
- decrease HRV/ERV blower speed
- humidity may have to be added through the use of humidifiers
- have a contractor balance HRV/ERV airflows

HRV/ERV and / or Ducts Frosting up

- HRV/ERV air flows are improperly balanced
- malfunction of the HRV/ERV defrost system

- Note: minimal frost build-up is expected on cores before unit initiates defrost cycle functions
- have HVAC contractor balance the HRV/ERV
- using the self-test feature at the Base Module, press the fan control symbol, the damper defrost unit should cycle its full travel when working properly.

Condensation or Ice Build Up in Insulated Duct to the Outside

- incomplete vapour barrier around insulated duct
- a hole or tear in outer duct covering

- tape and seal all joints
- tape any holes or tears made in the outer duct covering
- ensure that the vapour barrier is completely sealed

Water in the bottom of the HRV/ERV

- drain pans plugged
- improper connection of HRV/ERVs drain lines
- HRV/ERV is not level
- drain lines are obstructed
- HRV/ERV heat exchange core is not properly installed

- ensure O-Ring on drain nozzle sits properly
- look for kinks in line
- check water drain connections
- make sure water drains properly from pan

Technical Bulletin

When using the ControlAir 15 relay contacts to initiate blower operation on a furnace, certain thermostats will initiate the outdoor cooling condenser when R and G are closed.

Use this wiring configuration to stop the ControlAir15 relay contacts from initializing the condenser unit. This problem can occur at the thermostat because the Y terminal is connected to the G terminal internal to the stat. When R and G are closed at the furnace (by dehumidistat or relay) 24 Volts is sent to G at thermostat. 24 Volts is then sent through Y which will initiate outdoor condenser.

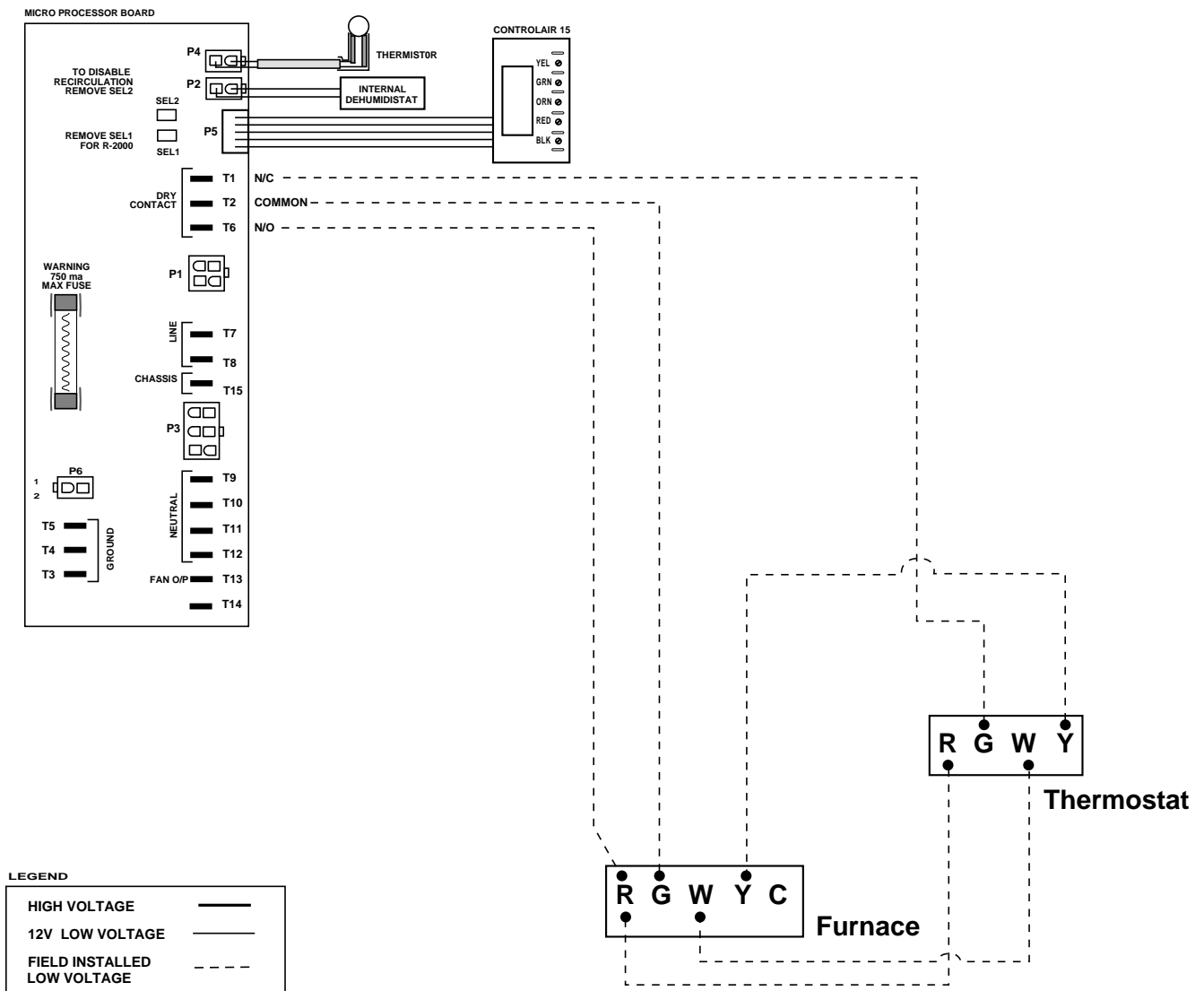

RESIDENTIAL WIRING DIAGRAM

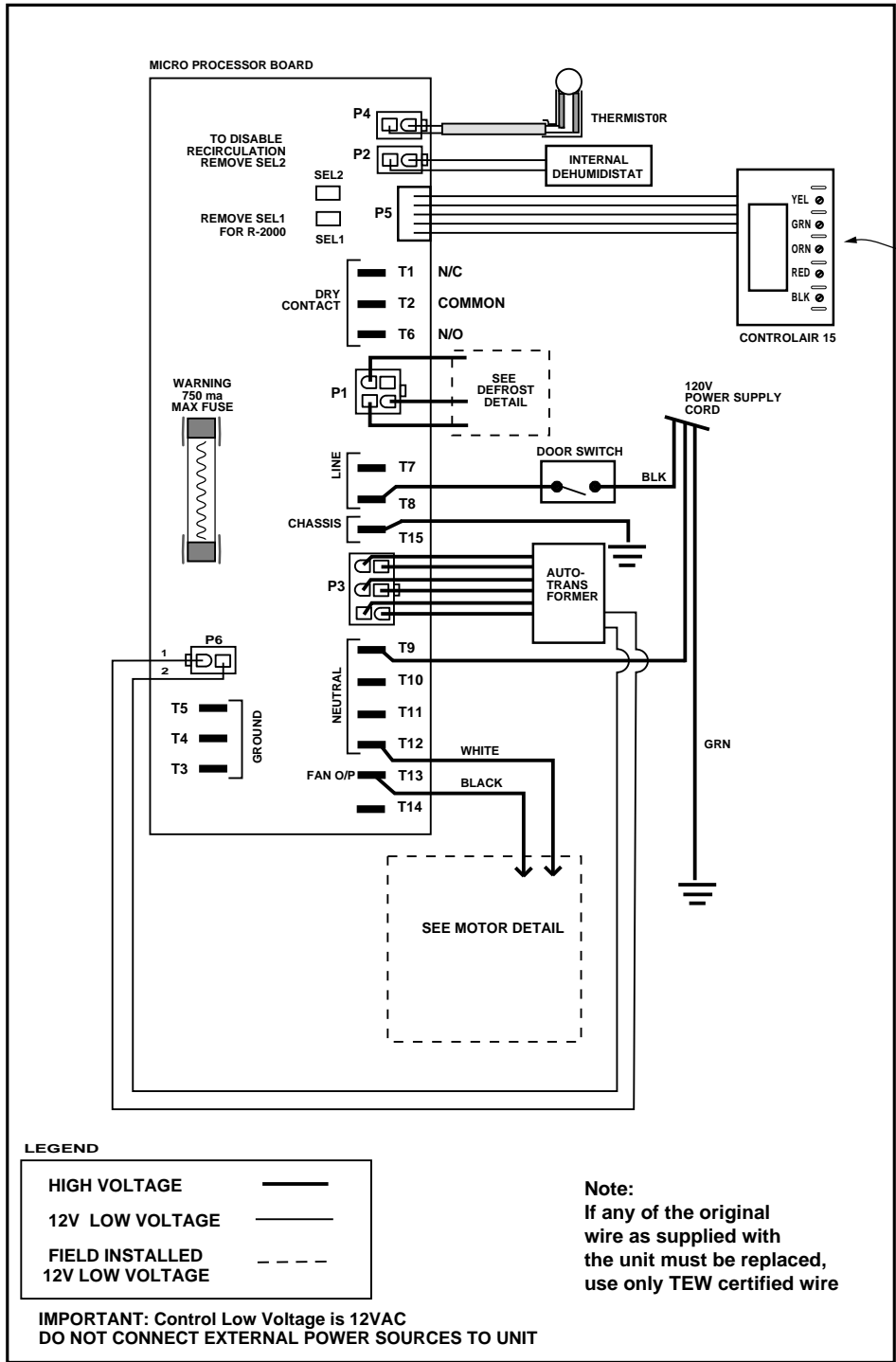

Note:
All control connections are labeled by colour. Connect to corresponding colour with low voltage wire (20 gauge minimum).
A dry contact closure between red & black will initiate high speed override.

LEGEND

HIGH VOLTAGE	—
12V LOW VOLTAGE	—
FIELD INSTALLED 12V LOW VOLTAGE	- - -

Note:
If any of the original wire as supplied with the unit must be replaced, use only TEW certified wire

IMPORTANT: Control Low Voltage is 12VAC
DO NOT CONNECT EXTERNAL POWER SOURCES TO UNIT

FAN MOTOR DETAILS

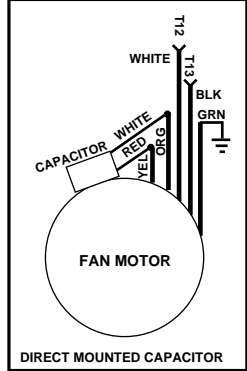

DEFROST DETAILS

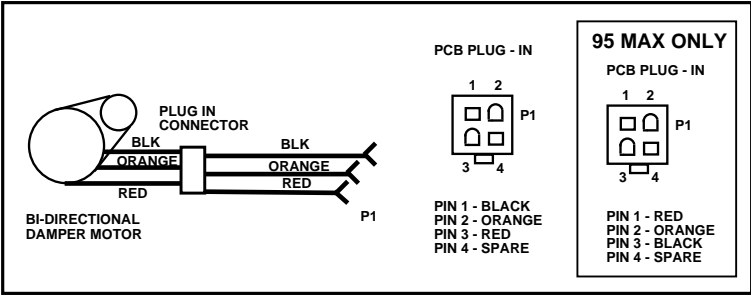

AUTO-TRANSFORMER DETAIL

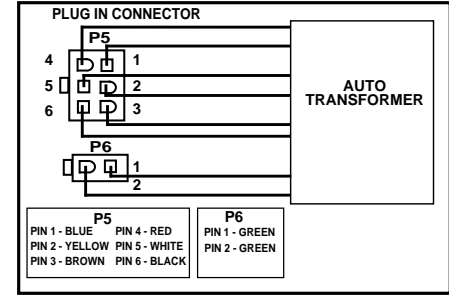

TI-89A-NE
0102

NUTECH
ENERGY SYSTEMS INC.

511 McCormick Blvd.
London, Ontario N5W 4C
Ph: (519) 457-1904
Fx: (519) 457-1676
Email: nutech@lifebreath.cc
Website: www.lifebreath.cor