

Before you can use the machine, you must set up the hardware and install the driver. Please read this "Quick Setup Guide" for proper set up and installation instructions.

Step 1



Setting Up the machine

Step 2



Installing the Driver & Software



Setup is Complete!

For the latest driver and to find the best solution for your problem or question, access the Brother Solutions Center directly from the driver or go to <http://solutions.brother.com>
Keep this "Quick Setup Guide", User's Guide and supplied CD-ROM in a convenient place for quick and easy reference at all times.

Setting Up
the machine

Windows[®]
USB

Windows[®]
Parallel

Windows
NT[®] 4.0







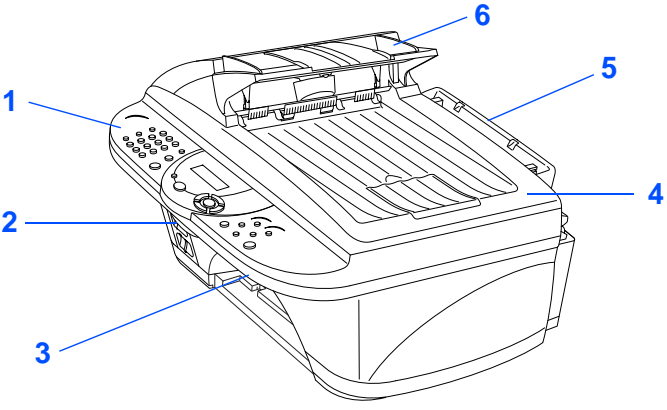
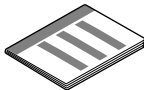

Mac[®] OS
8.5-9.2

Mac[®] OS X
10.1/10.2.1 or greater

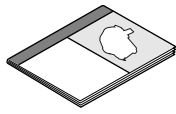
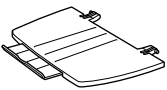
Installing the Driver & Software

Getting Started

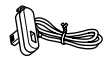
Carton Components

		 <p>Quick Setup Guide</p>	
		 <p>CD-ROM</p>	
		 <p>User's Guide</p>	
<p>1. Control Panel 2. Scanner Cover Release Lever 3. Scanner Cover</p>	<p>4. Document Cover 5. Paper Tray 6. Automatic Document Feeder (ADF)</p>		
 <p>Output Paper Support</p>	 <p>Paper Support</p>	 <p>Ink Cartridges (Black, Cyan, Yellow, Magenta)</p>	
 <p>Cable Tie and Filter Core for Parallel Interface Cable</p>	 <p>Telephone Line Cord</p>	 <p>Power Cord</p>	 <p>USB Cable</p>

Carton components may differ from one country to another.
Save all packing materials and the carton.



- The Parallel interface cable is not a standard accessory, if necessary purchase it.
- For Parallel use a shield interface cable that is IEEE 1284-compliant.
- Use only a parallel interface cable or USB interface cable that is not longer than 1.8 meters.

Control Panel

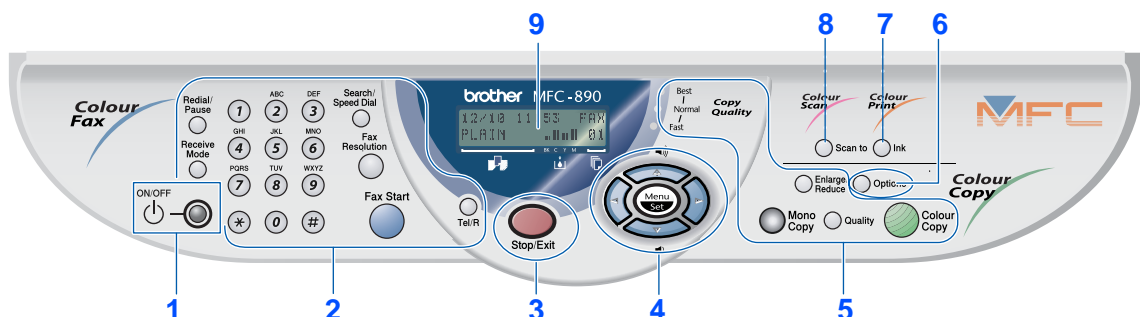

1. ON/OFF key	4. Navigation keys	7. Ink key
2. Fax and Telephone keys	5. Copy keys and indicators	8. Scan to key
3. Stop/Exit key	6. Options key	9. Liquid Crystal Display (LCD)



For more details, see Chapter 1 "MFC-890 control panel overview" in the User's Guide.

Table of Contents

Step 1 Setting Up the machine

1. Removing the Protective Parts.....	2
2. Attaching the Paper Supports	3
3. Load Paper	3
4. Install Phone Line and Power Cord.....	4
5. Installing the Ink Cartridges.....	5
6. Colour Block Quality and Alignment Check.....	7
7. Selecting a Receive Mode	8
8. Setting a Date and Time	9
9. Setting Your Station ID.....	9

Step 2 Installing the Driver & Software

Windows®	Supplied CD-ROM (MFC Software Suite).....	10
	For USB Interface Cable Users	
	(For Windows® 98/98SE/Me/2000 Professional/XP).....	12
	■ For Windows® 98/98SE/Me Users Only.....	15
	■ For Windows® 2000 Professional Users Only.....	17
	■ For Windows® XP Users Only.....	18
	For Parallel Interface Cable Users	
	(For Windows® 95/98/98SE/2000 Professional/XP).....	19
	■ For Windows® 95/98/98SE/Me Users Only.....	22
	■ For Windows® 2000 Professional Users Only.....	23
■ For Windows® XP Users Only.....	24	
For Windows NT® Workstation Version 4.0 Users	25	
Macintosh®	For Mac® OS 8.5 - 9.2 Users.....	28
	For Mac® OS X 10.1, 10.2.1 or Greater Users	30

 <p>Warning</p>
Indicates warnings that must be observed to prevent possible personal injury.

Indicates cautions that must be observed to use the machine properly or prevent damage to the machine.

 <p>Hint</p>
Indicates notes and useful tips to remember when using the machine.

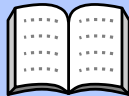
 <p>User's Guide</p>
Indicates reference to the User's Guide.

1 Removing the Protective Parts



Do NOT connect the interface cable. Connecting the interface cable is done when installing the driver.

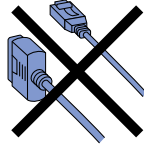

1 Remove the protective seals.

2 Open the scanner cover by pulling the release lever towards you.

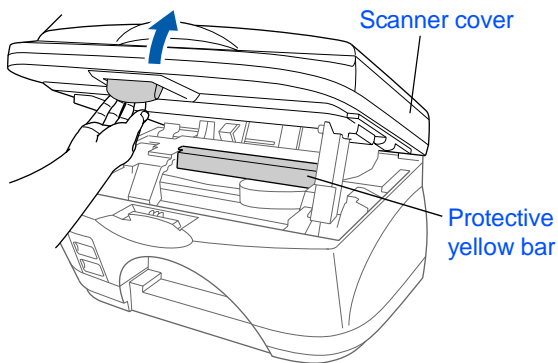

3 Remove the protective yellow bar and wiper stopper.

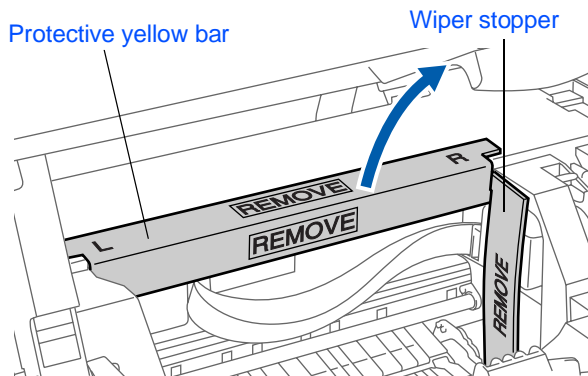

Do not throw away the protective yellow bar and wiper stopper. You will need it in the future to transport the machine.

4 Close the scanner cover.

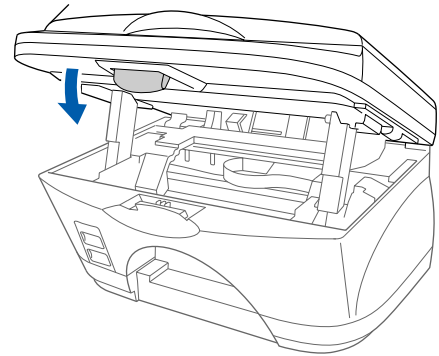

2 Attaching the Paper Supports

- 1 Attach the paper support to the paper tray.

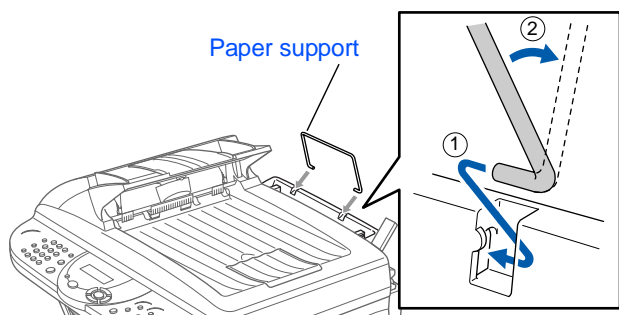

- 2 Attach the output paper support to the paper output slot, and then pull out the extension.

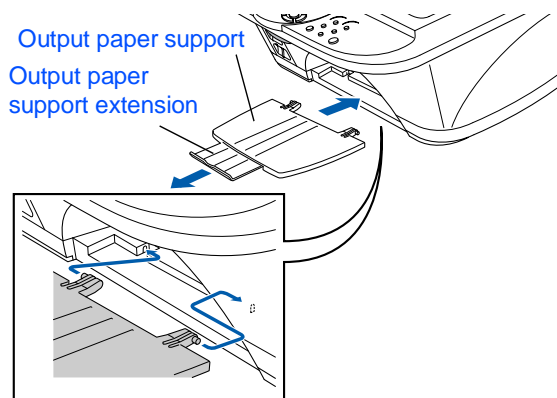

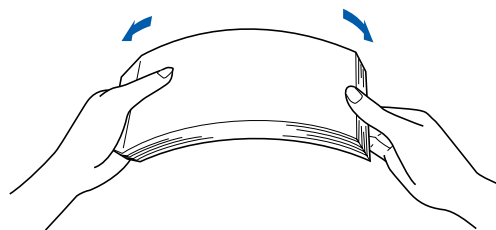

3 Load Paper

- 1 Fan the stack of paper well to avoid paper jams and misfeeds.

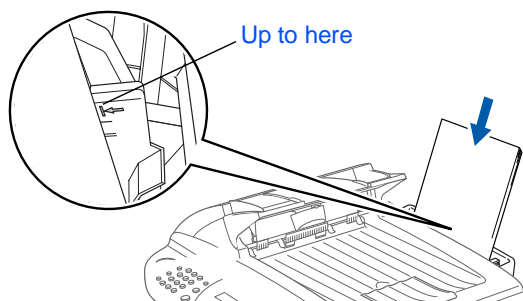

- 2 Gently insert the paper. Make sure the print side is towards you and the paper is below the maximum paper mark.



 You can load up to 100 sheets of 80 g/m² A4 size paper.

 For more details, see Chapter 2 "Paper" in User's Guide.

- 3 Press and slide the paper guide to fit the paper width.

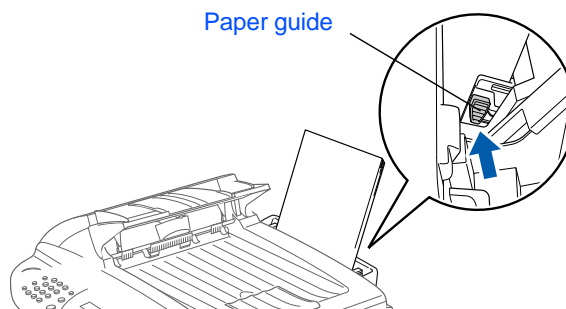

4 Install Phone Line and Power Cord

- 1 Connect the power cord.

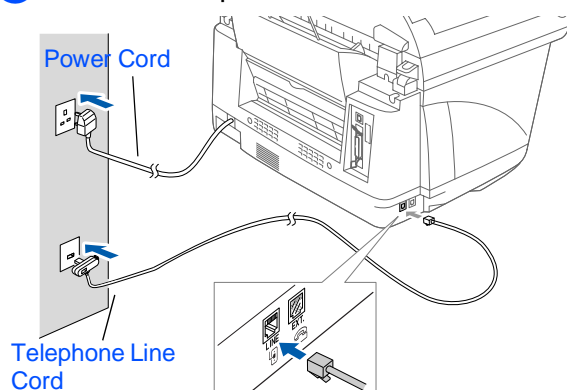

- 2 Connect one end of the telephone line cord to the jack on the machine marked LINE and the other end to a modular wall jack.

Do not connect the Parallel or USB cable yet.

Warning

- This machine must be fitted with an earthed plug.
- Since the machine is earthed via the mains plug, you can protect yourself from potentially hazardous electrical conditions on the telephone network by keeping the power to the machine on when you connect it to a telephone line. Similarly, you can protect yourself when you want to move the machine, by disconnecting the telephone line first, and then the power cord.

If you are sharing one phone line with an external telephone, connect it as shown below.

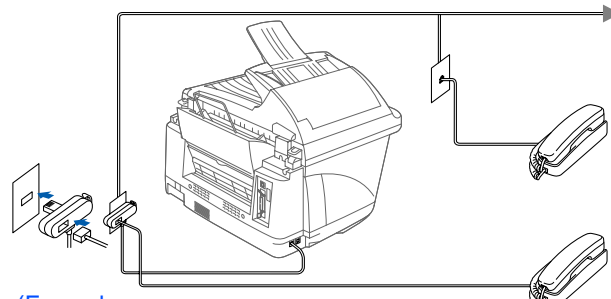

(Example for the U.K.)

If you are sharing one phone line with an external telephone answering machine, connect it as shown below.

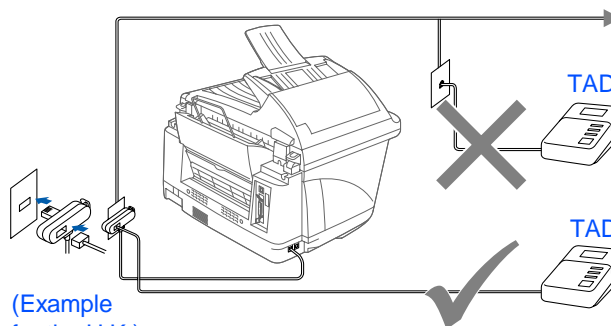

(Example for the U.K.)

*Please set the receive mode to **EXTERNAL TAD**.*

For more details, see Chapter 1 "Connecting the Machine" in User's Guide.

5 Installing the Ink Cartridges

Warning

If ink gets in your eyes irrigate them with water immediately, and if irritation occurs consult a doctor.

- 1 Make sure that the power is turned on. The LCD shows;

CHECK CARTRIDGE
Open cover, then...

- 2 Open the scanner cover by pulling the release lever towards you.

The print heads will move to the ink replacement position.

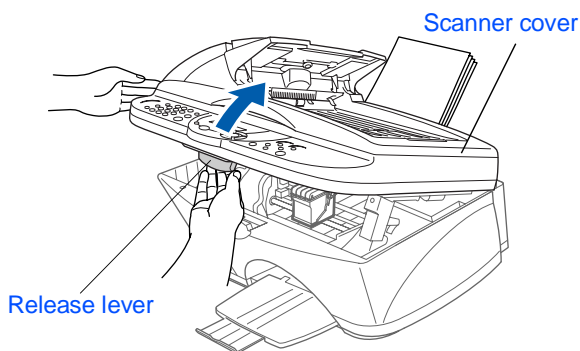

- 3 Push the four coloured ink cartridge covers one at a time so they pop up.

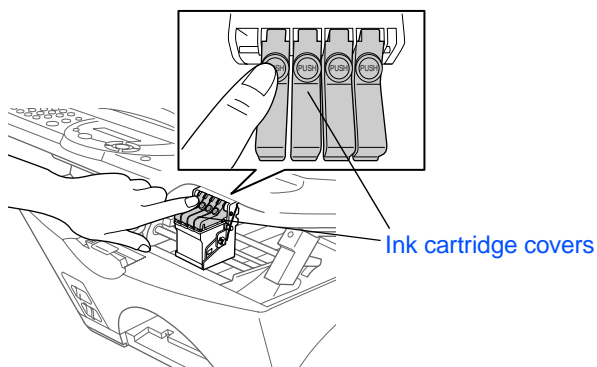

- 4 Remove the white shipping cover by pulling it towards you.

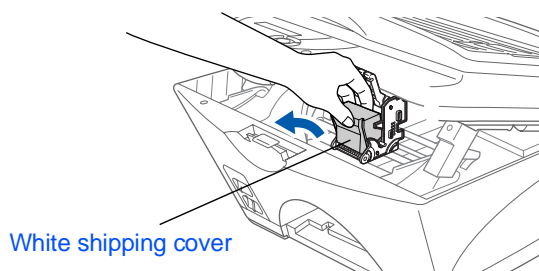

■ The bottom of the white shipping cover is wet with ink that will cause stains, so wipe it clean before you place it down.

■ Do not throw away the white shipping cover. You will need it when you transport the machine.

- 5 Take out black ink cartridge.

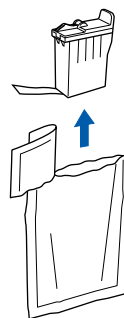

- 6 Carefully remove the sealing tape from the bottom of the ink cartridge.

To prevent spilling ink and staining your hands and clothing, peel the sealing tape gently and slowly.

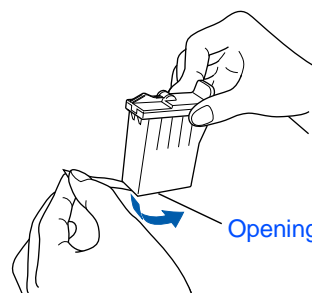

Do not touch the ink opening on the cartridge or removed tape.

Continued 

Step 1

Setting Up the machine

- 7 Gently insert the black ink cartridge in the black ink position.

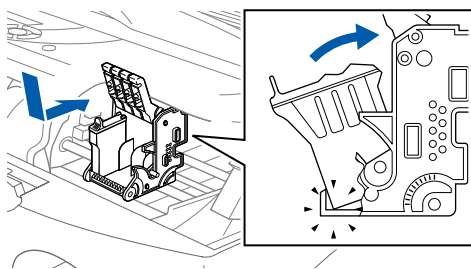

- 8 Press the cover down until it clicks.

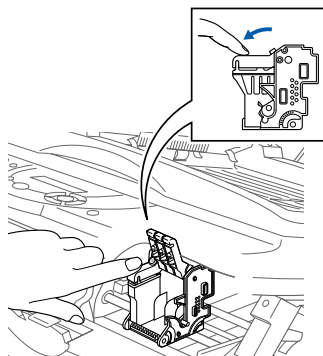

- 9 Repeat Steps 5 to 8 to install each colour ink cartridge. Match the colours of the ink cartridge covers.

- 10 Close the scanner cover. The machine will enter a head cleaning cycle for approximately **six minutes**.

CLEANING
PLEASE WAIT



- **DO NOT** remove ink cartridges if you do not need to replace them. If you do so, it may reduce the ink quantity and the machine will not know the quantity of ink left in the cartridge.
- **DO NOT** shake the ink cartridges. If you do so, the ink may spill when you take off the sealing tape. If ink stains your body or clothing, wash with soap or detergent immediately.
- **DO NOT** refill the ink cartridges. Attempting to use refilled cartridges and using incompatible inks may cause damage to the print head in this machine and such damage will not be covered by warranty. Warranty coverage does not apply to problems caused by the use of 3rd party ink or 3rd party ink cartridges. Use only genuine Brother ink cartridges.



- If you mix the colours by installing an ink cartridge in the wrong colour position, you must clean the print head several times after correcting the cartridge installation and before you start printing.
- Once you open an ink cartridge, install it in the machine and use it up within six months of installation. Use unopened ink cartridges by the expiration date written on the cartridge package.
- If **INK EMPTY** shows on the LCD after you install the ink cartridges, check to make sure the ink cartridges are installed correctly.

6

Colour Block Quality and Alignment Check

- 1 After the cleaning cycle is finished, the LCD shows;

SET PAPER AND
PRESS FAX START

- 2 Make sure the paper is loaded in the paper tray.
Press the **Fax Start** key.

- 3 The machine starts printing the PRINT QUALITY CHECK SHEET (only during initial ink cartridge installation).

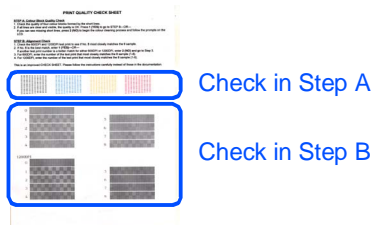

Step A: Colour Block Quality Check

- 1 The LCD shows:

IS STEP "A" OK?
1.YES 2.NO

Check the quality of the four colour blocks printed on the sheet.
(BLACK/CYAN/YELLOW/MAGENTA)

- 2 If all lines are clear and visible, press the ① key on the dial pad to go to **STEP B Alignment Check**.
—OR—

If you can see missing short lines, press the ② key on the dial pad and go to step 3.

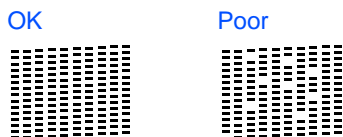

- 3 The LCD asks you if the print quality is OK for each colour. Press the ① key or ② key on the dial pad.

BLACK OK?
1.YES 2.NO

When you have finished selecting the ① key (YES) or the ② key (NO) for each colour, the LCD shows:

START CLEANING?
1.YES 2.NO

Press the ① key (YES), and then machine starts cleaning the colours.

After cleaning is finished, press the **Fax Start** key. The machine starts printing PRINT QUALITY CHECK SHEET again and goes back to the first step of STEP A.

Step B: Alignment Check

- 1 The LCD shows:

IS STEP "B" OK?
1.YES 2.NO

Check the 600 DPI and 1200 DPI test print to see if **No.5** most closely matches the OK sample (**No.0**). Press the ① key if **No.5** matches it.

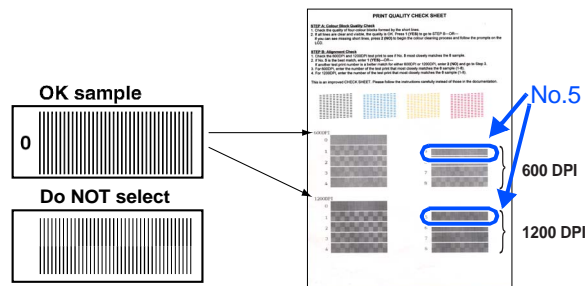

- 1 If another test print number is a better match for either 600 DPI or 1200 DPI, press the ② key to select **NO** and go to step 2.
- 2 For 600 DPI, select the number from 1 to 8 that most closely matches the **No.0** sample and enter it using the dial pad.

600DPI ADJUST
SELECT BEST #

- 3 For 1200 DPI, enter the number from 1 to 8 that most closely matches the **No.0** sample.

1200DPI ADJUST
SELECT BEST #

The Quality check is now complete.

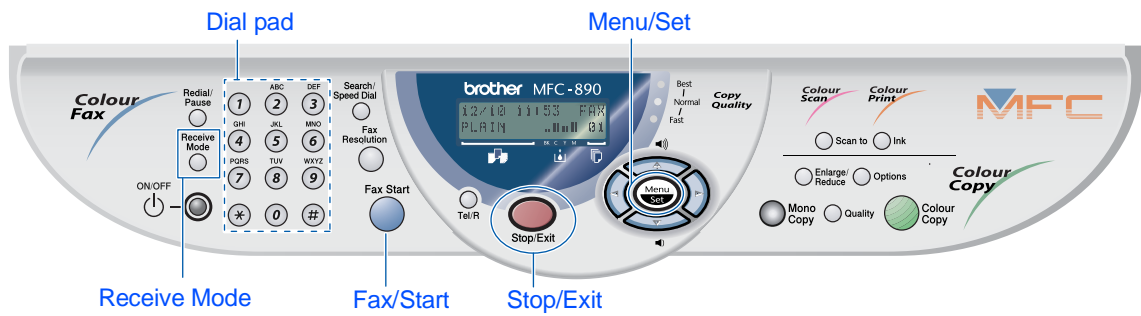

7 Selecting a Receive Mode

Choose the mode which best suits your needs by pressing the **Receive Mode** key repeatedly.

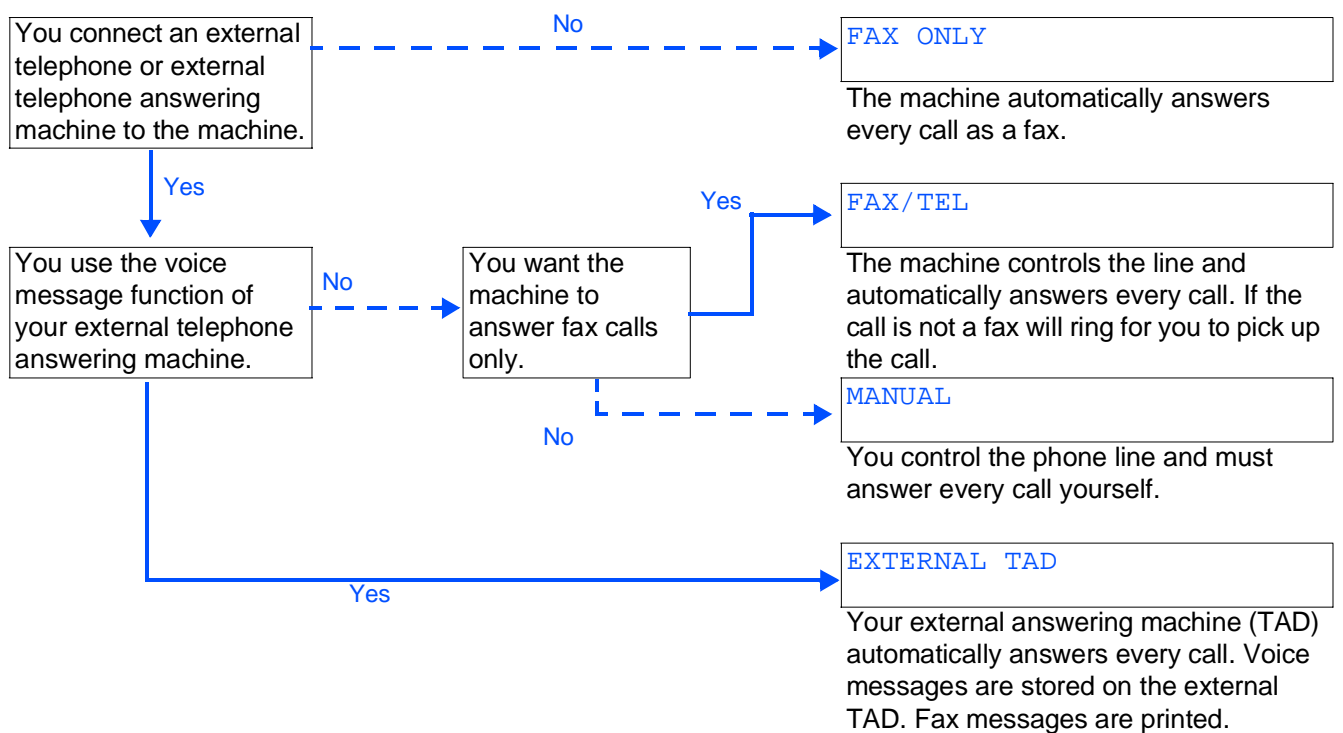

For more details, see of Chapter 5 "Setup Receive" in User's Guide.

8 Setting a Date and Time

The machine displays the date and time, and prints it on every fax you send.

- 1 Press the **Menu/Set** key.
- 2 Press the **1** key.
- 3 Press the **2** key.
- 4 Enter the last two digits of the year on the dial pad, and then press the **Menu/Set** key.

```
DATE/TIME
YEAR: 03
```

(e.g. Enter **0, 3** for 2003.)

- 5 Enter the two digits for the month on the dial pad, and then press the **Menu/Set** key.

```
DATE/TIME
MONTH: 09
```

(e.g. Enter **0, 9** for September.)

- 6 Enter the two digits for the day on the dial pad, and then press the **Menu/Set** key.

```
DATE/TIME
DAY: 06
```

(e.g. Enter **0, 6**.)

- 7 Enter the time in 24-hour format on the dial pad, and then press the **Menu/Set** key.

```
DATE/TIME
TIME: 15:25
```

(e.g. Enter **1, 5, 2, 5** for 3:25 P.M.)

- 8 Press the **Stop/Exit** key.

 If you want to repeat from step 1, press the **Stop/Exit** key.

9 Setting Your Station ID

You should store your name and fax number to be printed on all fax pages that you send.

- 1 Press the **Menu/Set** key.
- 2 Press the **1** key.

- 3 Press the **3** key.

- 4 Enter your fax number (up to 20 digits) on the dial pad, and then press the **Menu/Set** key.

```
STATION ID
FAX: 908XXXXXXXXX
```

- 5 Enter your telephone number (up to 20 digits) on the dial pad, and then press the **Menu/Set** key.
(If your telephone number and fax number are the same, enter the same number again.)

```
STATION ID
TEL: 908XXXXXXXXX
```

- 6 Use the dial pad to enter your name (up to 20 characters), and then press the **Menu/Set** key.

```
STATION ID
NAME: ANDY
```



Refer to the following chart for entering your name.

Press key	One time	Two times	Three times	Four times
2	A	B	C	2
3	D	E	F	3
4	G	H	I	4
5	J	K	L	5
6	M	N	O	6
7	P	Q	R	S
8	T	U	V	8
9	W	X	Y	Z



For more details, see Chapter 4 "Setting the Station ID" in User's Guide.

- 7 Press the **Stop/Exit** key.



If you want to repeat from step 1, press the **Stop/Exit** key.

Go to Next page to
install the driver

Supplied CD-ROM (MFC Software Suite)

You can find a variety of information on the CD-ROM.

Windows®



Install Software

You can install printer, PC FAX Send/Receive, scanner drivers and the various utility items, including Paper Port and TextBridge OCR.



User Guides

View the User's Guide and other documentation in PDF format.



Brother Solutions Center

You can access the Brother Solutions Center which is a Web site offering information about your Brother product including FAQs, User Guides, Driver updates and Tips for using your machine.

Macintosh®

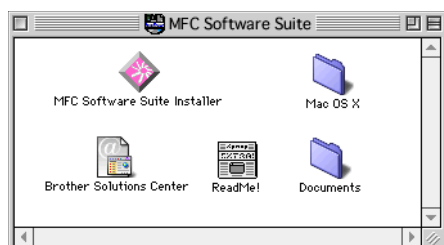

MFC Software Suite Installer

You can install printer, PC FAX Send, and scanner drivers for Mac OS 8.5 - 9.2 (scanner driver only available for Mac OS 8.6 - 9.2)



Documents

View the User's Guide and other documentations in PDF format.



Mac OS X (For Native Mac OS X 10.1, 10.2.1 or greater)

You can install the printer, scanner drivers and remote setup program for Mac OS X. (Scanner driver is only available for OS X 10.2.1 or greater.)



Brother Solutions Center

You can access the Brother Solutions Center which is a Web site offering information about your Brother product including FAQs, User Guides, Driver updates and Tips for using your machine.



ReadMe!

You can get important information and troubleshooting tips.



Follow the instructions on this page for your operating system and interface cable.

Setting Up
the MFC

Windows®



USB Interface Cable Users Go to page 12
(For Windows® 98/98SE/Me/2000 Professional/XP)

Windows®
USB



Parallel Interface Cable Users..... Go to page 19
(For Windows® 95/98/98SE/Me/2000 Professional/XP)

Windows®
Parallel



Windows NT® Workstation Version 4.0 Users Go to page 25
(For Parallel Interface Cable Users)

Windows
NT® 4.0

Macintosh®



For Mac® OS 8.5 to 9.2 Users..... Go to page 28

Mac® OS
8.5-9.2



For Mac® OS X 10.1, 10.2.1 or Greater Users Go to page 30

Mac® OS X
10.1/10.2.1 or greater

For USB Interface Cable Users (For Windows® 98/98SE/Me/2000 Professional/XP)

Make sure that you have completed the instructions from Step 1 “Setting Up the machine”.

If you are using Windows® 2000 Professional:

To access the PhotoCapture Center™ features from your PC you must be connected using USB and you may have to install a Windows® 2000 update first.

There are two ways to install the Windows® 2000 update:

- A) Download Service Pack 3 from the Microsoft® Web page and install it.
We recommend this method because it includes other bug fixes for Windows® 2000.
- B) Install the Windows® 2000 update from the MFC Software Suite installer.
You can install it by following the steps below:
 - 1. Follow the installation steps from ① to ⑧.
 - 2. Click **OK** to start installation of the update.
 - 3. Click **OK** to restart your PC.
 - 4. After the PC restarts, the installation will automatically continue.



*If the installation does not continue automatically, please open the MFC Software Suite installer menu again by double-clicking the **setup.exe** program on the Brother CD-ROM, and continue from Step ⑤ to install the MFC Software Suite.*

- ① Make sure any media cards are not inserted into the media drive of the machine.
- ② Unplug the machine from the AC outlet and disconnect it from your computer, if you are already connected to an interface cable.

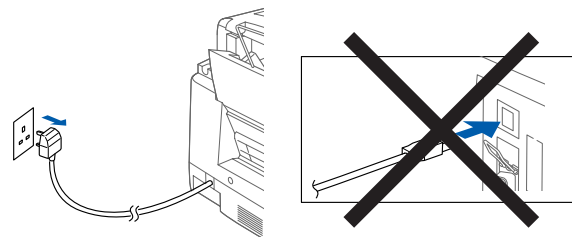

- ③ Turn on your computer.
(For Windows® 2000 Professional/XP, you must be logged on as the administrator.)
- ④ Insert the supplied CD-ROM into your CD-ROM drive.



- ⑤ Click your language.
- ⑥ The CD-ROM main menu will appear. Click **Install Software**.



If this window does not appear, use Windows® Explorer to run the setup.exe program from the root directory of the Brother CD-ROM.

- 7 Click **MFC Software Suite** in Main Application.

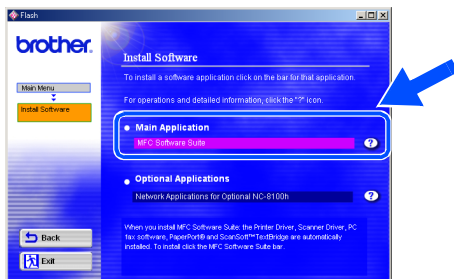

MFC Software Suite includes Printer Driver, Scanner Driver, ScanSoft™ PaperPort®, ScanSoft™ Text Bridge®, PC-FAX software, Remote Setup and True Type fonts. PaperPort® is a document management application for viewing scanned documents. ScanSoft™ TextBridge®, which is integrated into PaperPort®, is an OCR application that converts an image into text and inserts it into your default word processor.

- 8 Click **Install**.

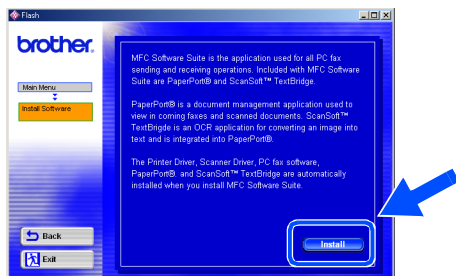

If you see the following screen, click **OK** to install the Windows® updates. After the updates are installed your PC will restart and automatically continue the installation.

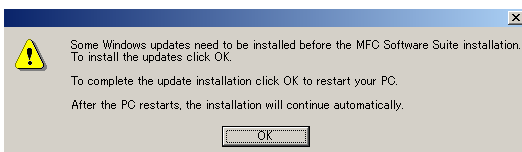

If the installation does not continue automatically, please open the installer menu again by double-clicking the **setup.exe** program on the Brother CD-ROM, and continue from Step 5.

- 9 When the **PaperPort® 8.0 SE Setup** window is displayed, click **Next**.

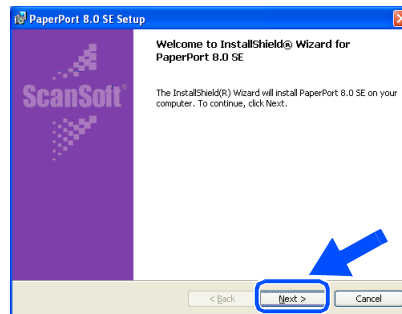

- 10 After reading and accepting the License Agreement, enter your user information and click **Next**.

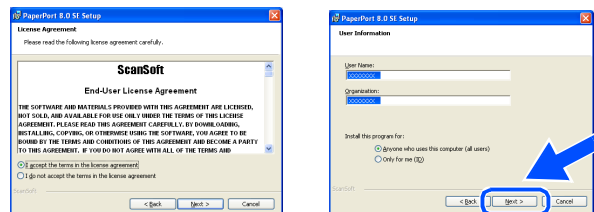

- 11 Select **Typical** and click **Next**.

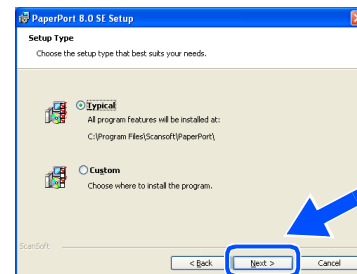

- 12 Click **Install** and PaperPort® will start installing on your computer.

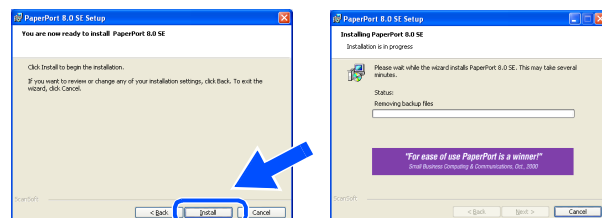

Continued

Step 2

Installing the Driver & Software

For USB Interface Cable Users (For Windows® 98/98SE/Me/2000 Professional/XP)

- 13 When the Registration screen is displayed, make your selection and follow the on screen instructions.

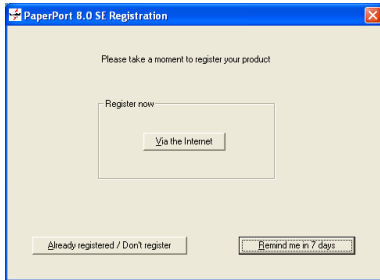

- 14 Click **Finish** to complete installation.

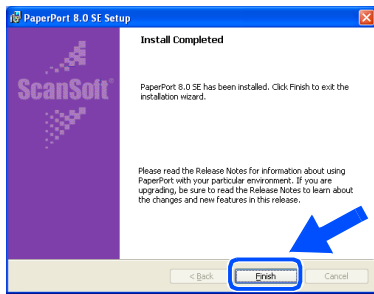

- 15 When the Brother MFC Software Suite Installation window appears, click **Next**.

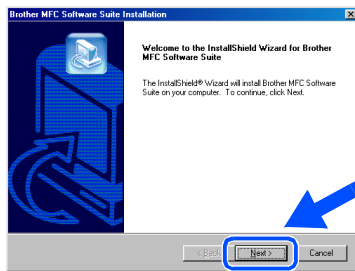

If an error message appears during the installation process, or if you have previously installed the MFC Software Suite, you will first have to uninstall it. From the **Start** menu, select **Programs, Brother, Brother MFC Software Suite, Uninstall**, and then follow the instructions on the screen.

- 16 When Software License Agreement window appears, click **Yes**.

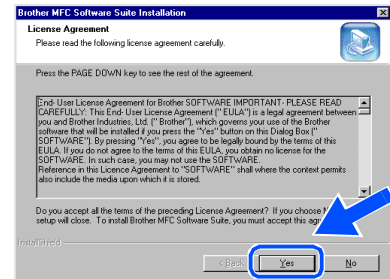

- 17 Select **Standard**, and then click **Next**. The application files will be copied to your computer.

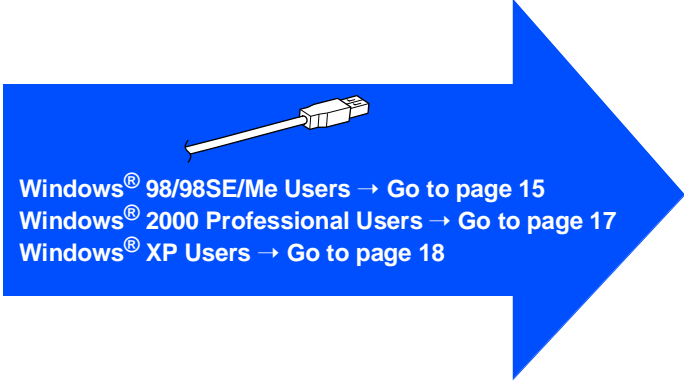
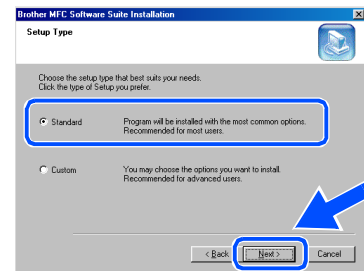

Windows® 98/98SE/Me Users → Go to page 15
Windows® 2000 Professional Users → Go to page 17
Windows® XP Users → Go to page 18

For Windows® 98/98SE/Me Users Only

- 18 When this screen appears, turn on the machine by plugging in the power cord. Connect the USB interface cable to your PC, and then connect it to the machine.

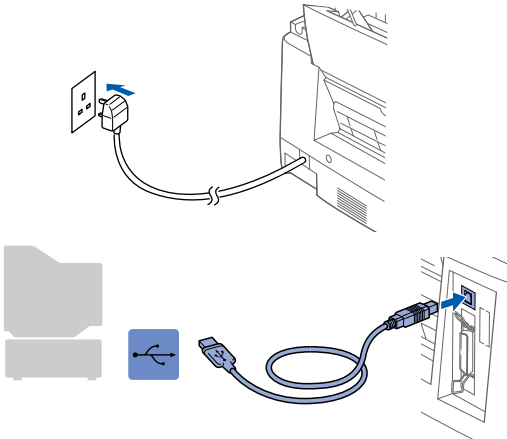
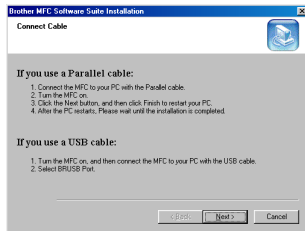

It will take a few seconds for the installation screen to appear.

The installation of the Brother driver will automatically start. Follow the instructions on the screen.

- 19 Select **BRUSB: USB Printer Port**, and then click **Next**.

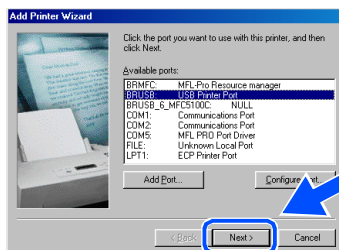

- 20 Accept the default Printer name by selecting **Yes**, and then click **Next**.

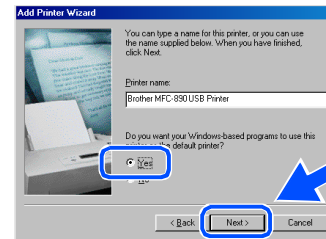

- 21 Select **Yes (recommended)**, and then click **Finish**. A test page will be printed so you can check the print quality.

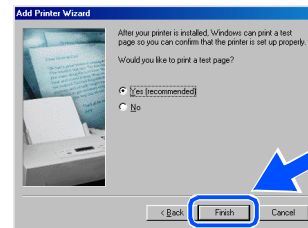

- 22 If the test page is printed correctly, click **Yes**. If you click **No**, follow the prompts on the screen to correct the problem.

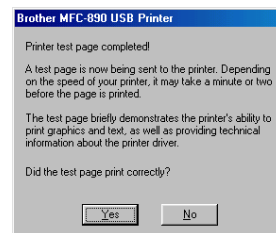

Continued

For USB Interface Cable Users (For Windows® 98/98SE/Me/2000 Professional/XP)

- 23 Click **Finish** to restart your computer.

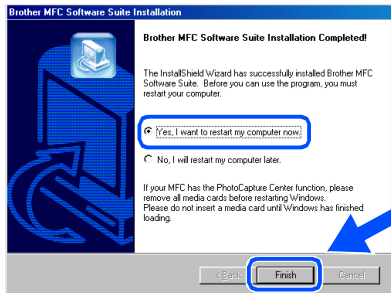

- 24 After the computer restarts, click **Yes** to have the Control Center loaded each time Windows is started. The Control Center will appear as an icon in the task tray.
If you click **No** the Scan keys on the machine will be disabled.

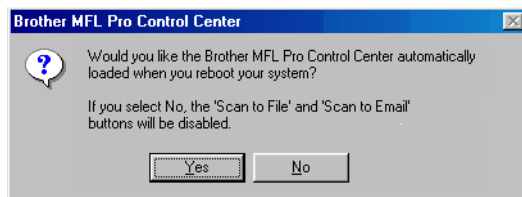

Even if you select **NO**, later you will be able to launch the Brother Control Center to use the **Scan to** key. See “AutoLoad the Brother Control Center”, Chapter 14 in the On-Line Documentation (User’s Guide) on the CD-ROM.



The Brother PC fax, Printer and Scanner drivers have been installed and the installation is now complete.

For Windows® 2000 Professional Users Only

- 18 When this screen appears, turn on the machine by plugging in the power cord. Connect the USB interface cable to your PC, and then connect it to the machine.

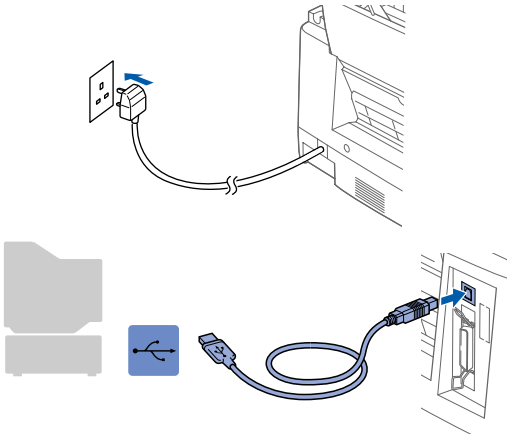
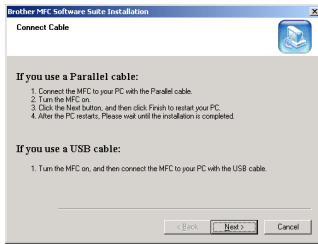

- 19 It will take a few seconds for the installation screen to appear. The installation of the Brother driver will automatically start. Follow the instructions on the screen.

- 20 If the **Digital Signature Not Found** dialog boxes appear, click **Yes** to install the driver.

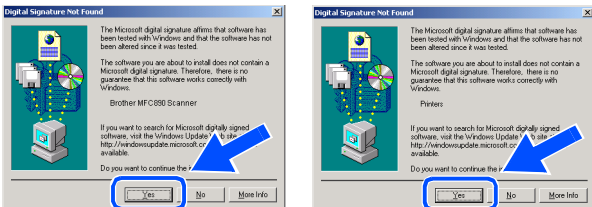

- 21 Click **Finish** to restart your computer.

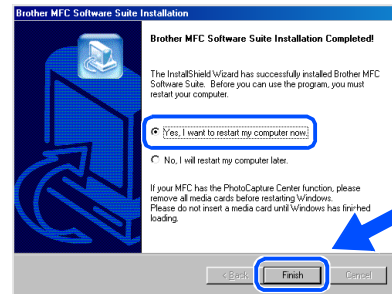

- 22 After the computer restarts, click **Yes** to have the Control Center loaded each time Windows is started. The Control Center will appear as an icon in the task tray. If you click **No** the Scan keys on the machine will be disabled.

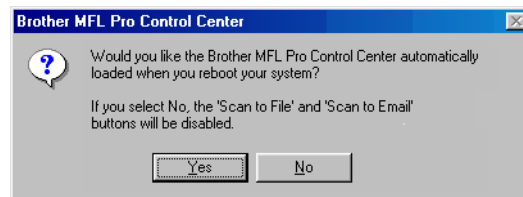

- Even if you select **NO**, later you will be able to launch the Brother Control Center to use the **Scan to** key. See "AutoLoad the Brother Control Center", Chapter 14 in the On-Line Documentation (User's Guide) on the CD-ROM.*

- OK! The Brother PC fax, Printer and Scanner drivers have been installed and the installation is now complete.

For USB Interface Cable Users (For Windows® 98/98SE/Me/2000 Professional/XP)

For Windows® XP Users Only

- 18 When this screen appears, turn on the machine by plugging in the power cord. Connect the USB interface cable to your PC, and then connect it to the machine.

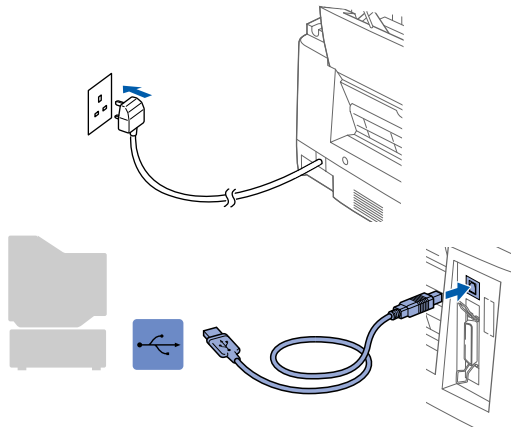
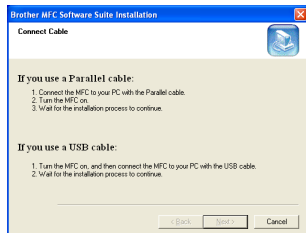

It will take a few seconds for the installation screen to appear.

The installation of the Brother driver will automatically start. Follow the instructions on the screen.

- 19 Click **Finish** to restart your computer.

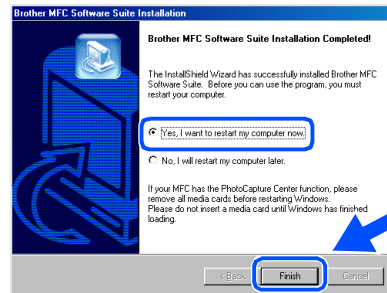

- OK!** The Brother PC fax, Printer and Scanner drivers have been installed and the installation is now complete.

For Parallel Interface Cable Users (For Windows® 95/98/98SE/Me/2000 Professional/XP)

Make sure that you have completed the instructions from Step 1 “Setting Up the machine”.

- 1 Unplug the machine from the AC outlet and disconnect it from your computer, if you have already connected an interface cable.

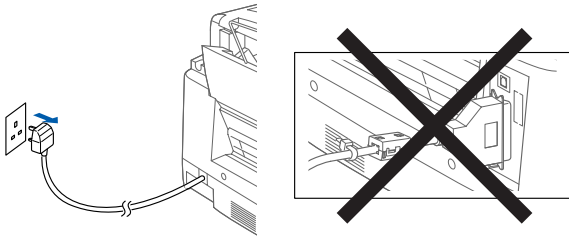

- 2 Turn on your computer.
(For Windows® 2000 Professional/XP, you must be logged on as the administrator.)
- 3 Insert the supplied CD-ROM into your CD-ROM drive.



- 4 Click your language.
- 5 The CD-ROM main menu will appear.
Click **Install Software**.



If this window does not appear, use Windows® Explorer to run the *setup.exe* program from the root directory of the Brother CD-ROM.

- 6 Click **MFC Software Suite** in Main Application.



MFC Software Suite includes Printer Driver, Scanner Driver, ScanSoft™ PaperPort®, ScanSoft™ Text Bridge®, PC-FAX software, Remote Setup and True Type fonts. PaperPort® is a document management application for viewing scanned documents. ScanSoft™ TextBridge®, which is integrated into PaperPort®, is an OCR application that converts an image into text and inserts it into your default word processor.

- 7 Click **Install**.

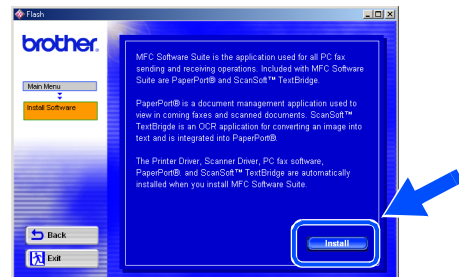

If you see the following screen, click **OK** to install the Windows® updates. After the updates are installed your PC will restart and automatically continue the installation.



If the installation does not continue automatically, please open the installer menu again by double-clicking the **setup.exe** program on the Brother CD-ROM, and continue from Step 4.



Step 2

Installing the Driver & Software

For Parallel Interface Cable Users (For Windows[®] 95/98/98SE/Me/2000 Professional/XP)

- 8 When the PaperPort[®] 8.0 SE Setup window is displayed, click **Next**.

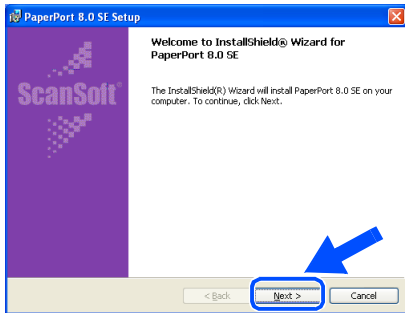

- 9 After reading and accepting the License Agreement, enter your user information and click **Next**.

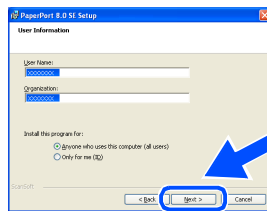

- 10 Select **Typical** and click **Next**.

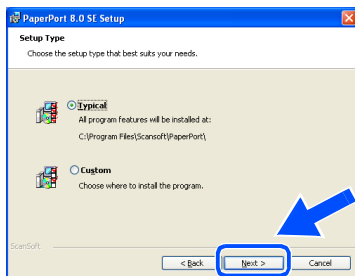

- 11 Click **Install** and PaperPort[®] will start installing on your computer.

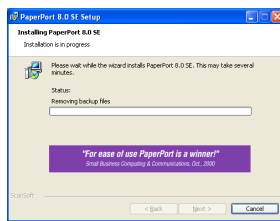
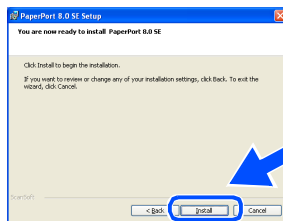

- 12 When the Registration screen is displayed, make your selection and follow the on screen instructions.

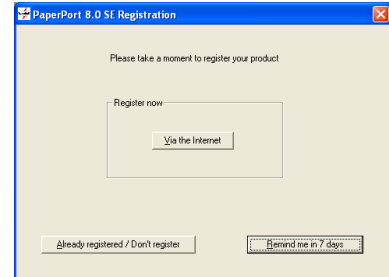

- 13 Click **Finish** to complete installation.

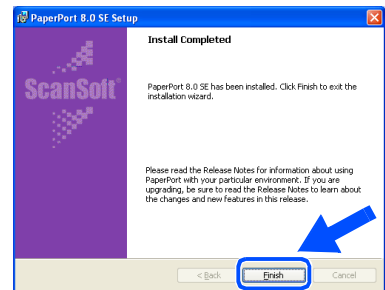

- 14 When the **Brother MFC Pro Suite Installation** window appears, click **Next**.

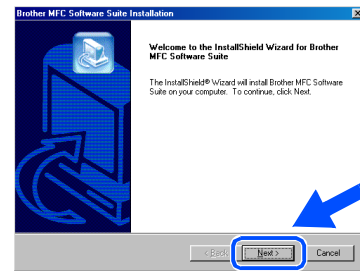

If an error message appears during the installation process, or if you have previously installed the MFC Software Suite, you will first have to uninstall it. From the **Start** menu, select **Programs, Brother, Brother MFC Software Suite, Uninstall**, and then follow the instructions on the screen.

- 15 When Software License Agreement window appears, click **Yes**.

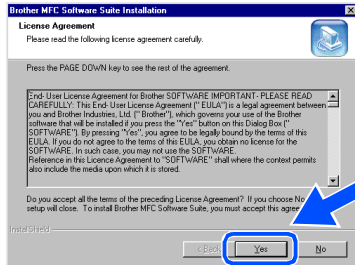

- 16 Select **Standard**, and then click **Next**.
The application files will be copied to your computer.

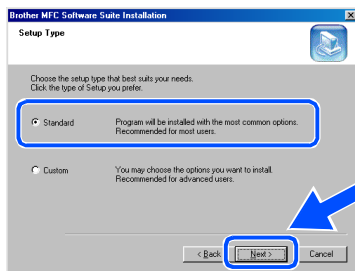

You must attach the bundled filter core and cable tie to the parallel interface cable before you connect it to your PC and the machine.

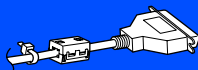

Windows® 95/98/98SE/Me Users → Go to page 22
Windows® 2000 Professional Users → Go to page 23
Windows® XP Users → Go to page 24

For Parallel Interface Cable Users (For Windows® 95/98/98SE/Me/2000 Professional/XP)

For Windows® 95/98/98SE/Me Users Only

- 17 When this screen appears, connect the parallel interface cable to your PC, and then connect it to the machine.

Turn on the machine by plugging in the power cord.

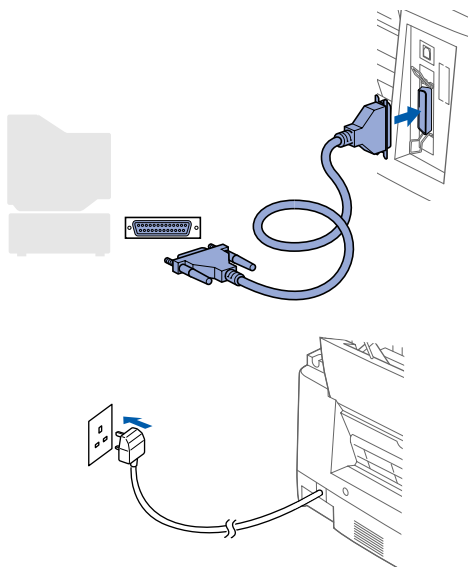
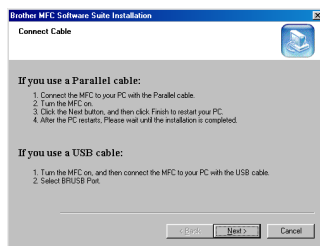

- 18 Click **Next**.

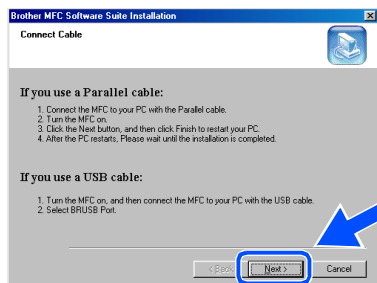

- 19 Click **Finish** to restart your computer.

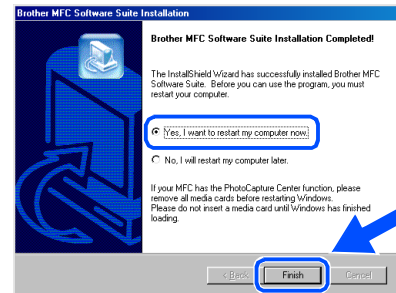

- 20 After the computer restarts, the installation of the Brother driver will automatically start. Follow the instructions on the screen.

- 21 Click **Yes** to have the Brother MFL-Pro Control Center loaded each time Windows is started. The Control Center will appear as an icon in the task tray.

If you click **No** the Scan keys on the machine will be disabled.

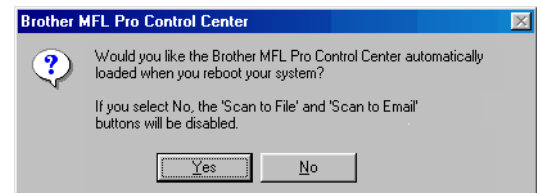

*Even if you select **NO**, later you will be able to launch the Brother Control Center to use the **Scan to** key. See "AutoLoad the Brother Control Center", Chapter 14 in the On-Line Documentation (User's Guide) on the CD-ROM.*

- OK!** The Brother PC fax, Printer and Scanner drivers have been installed and the installation is now complete.

For Windows® 2000 Professional Users Only

- 17 When this screen appears, connect the parallel interface cable to your PC, and then connect it to the machine.
- Turn on the machine by plugging in the power cord.

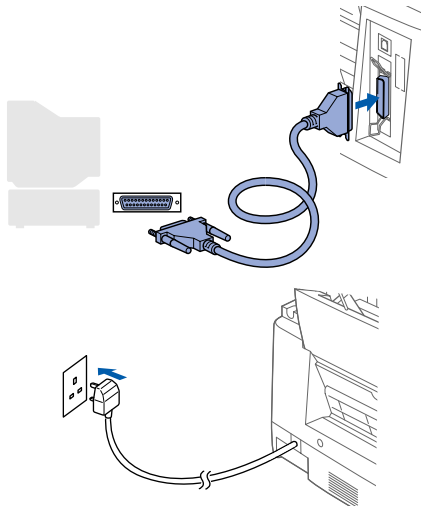
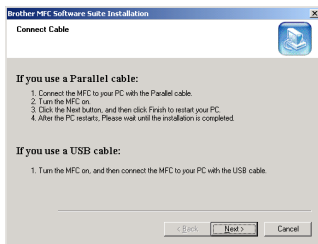

- 18 Click the **Next**.

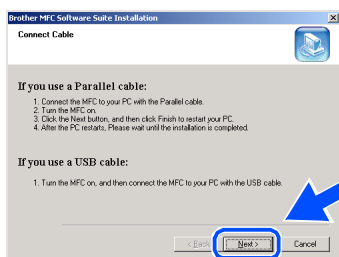

- 19 Click **Finish** to restart your computer.

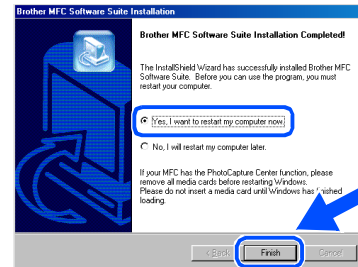

- 20 After the computer restarts, the installation of the Brother driver will automatically start. Follow the instructions on the screen.
- 21 If the **Digital Signature Not Found** dialog boxes appear, click **Yes** to install the driver.

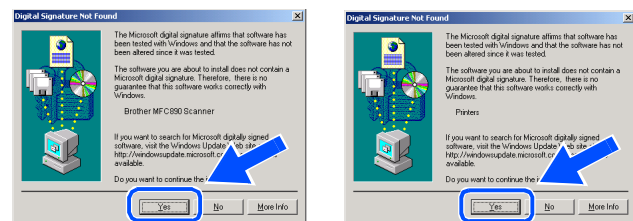

- 22 Click **Yes** to have the Control Center loaded each time Windows is started. The Control Center will appear as an icon in the task tray.
- If you click **No** the Scan keys on the machine will be disabled.

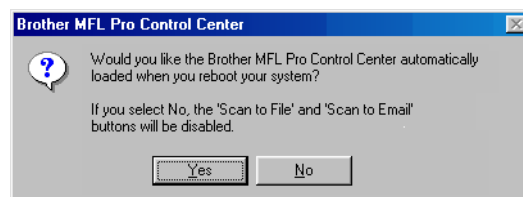

Even if you select **NO**, later you will be able to launch the Brother Control Center to use the **Scan to** key. See "AutoLoad the Brother Control Center", Chapter 14 in the On-Line Documentation (User's Guide) on the CD-ROM.



The Brother PC fax, Printer and Scanner drivers have been installed and the installation is now complete.

For Parallel Interface Cable Users (For Windows® 95/98/98SE/Me/2000 Professional/XP)

For Windows® XP Users Only

- 17 When this screen appears, connect the parallel interface cable to your PC, and then connect it to the machine.

Turn on the machine by plugging in the power cord.

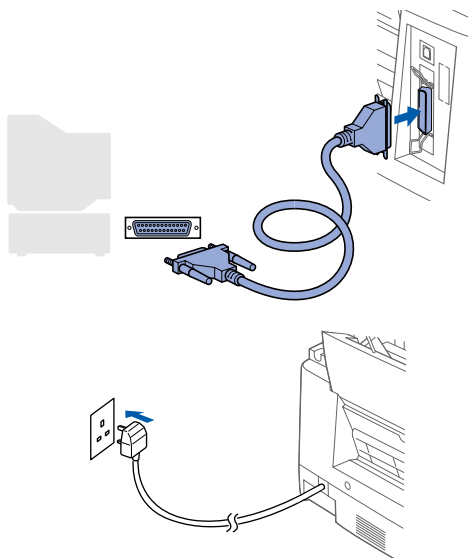
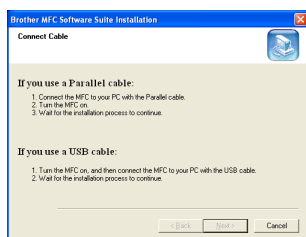

The installation of the Brother driver will automatically start. Follow the instructions on the screen.

- 18 When the following screen appears, click **Finish** and wait as the PC restarts Windows and continues the installation.

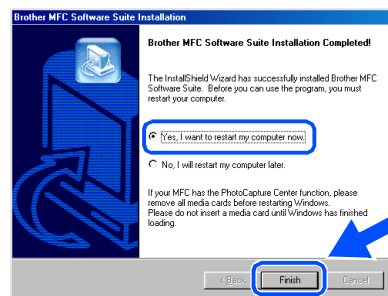

- OK! The Brother PC fax, Printer and Scanner drivers have been installed and the installation is now complete.

For Windows NT® Workstation Version 4.0 Users

Make sure that you have completed the instructions from Step 1 “Setting Up the machine”.

- 1 Turn on your computer.
You must be logged on as the Administrator.
- 2 Connect the parallel interface cable to your computer, and then connect it to the machine.

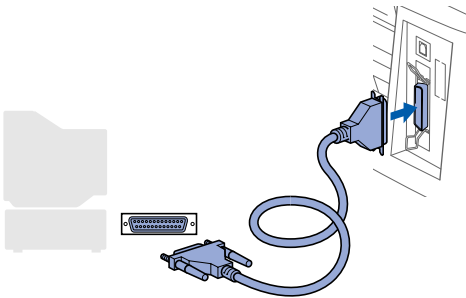

- 3 Make sure you turned on the machine by plugging in the power cord.

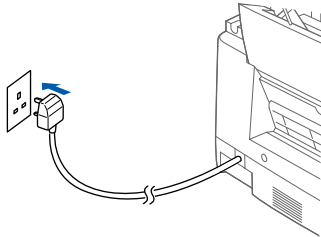

- 4 Insert the Supplied CD-ROM into your CD-ROM drive.



- 5 Click your language.

- 6 The CD-ROM main menu will appear.
Click **Install Software**.



 If this window does not appear, use Windows® Explorer to run the setup.exe program from the root directory of the Brother CD-ROM.

- 7 Click **MFC Software Suite** in Main Application.

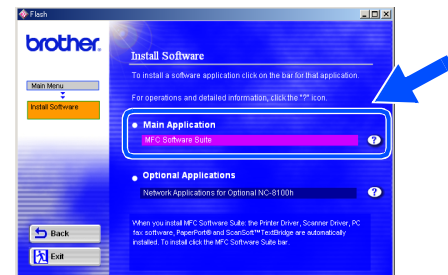

 MFC Software Suite includes Printer Driver, Scanner Driver, ScanSoft™ PaperPort®, ScanSoft™ Text Bridge®, PC-FAX software, Remote Setup and True Type fonts. PaperPort® is a document management application for viewing scanned documents. ScanSoft™ TextBridge®, which is integrated into PaperPort®, is an OCR application that converts an image into text and inserts it into your default word processor.

Continued 

Step 2

Installing the Driver & Software

 For Windows NT® Workstation Version 4.0 Users

8 Click **Install**.

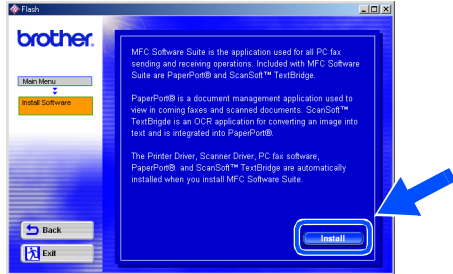

 If you see the following screen, click **OK** to install the Windows® updates. After the updates are installed your PC will restart and automatically continue the installation.

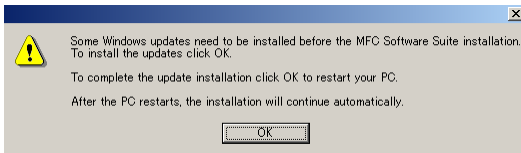

If the installation does not continue automatically, please open the installer menu again by double-clicking the **setup.exe** program on the Brother CD-ROM, and continue from Step 6.

9 When the **PaperPort® 8.0 SE Setup** window is displayed, click **Next**.

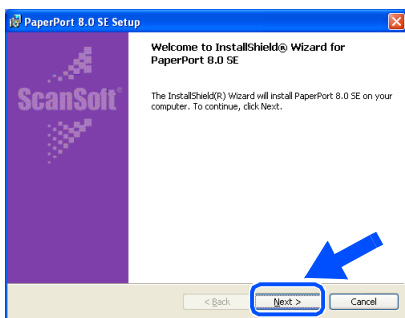

10 After reading and accepting the License Agreement, enter your user information and click **Next**.

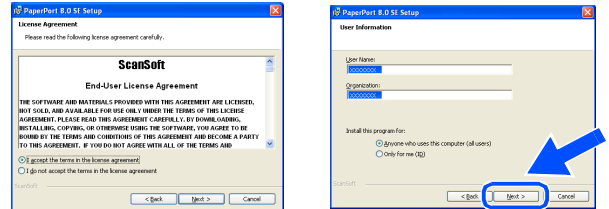

11 Select **Typical** and click **Next**.

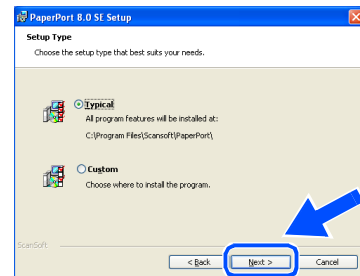

12 Click **Install** and PaperPort® will start installing on your computer.

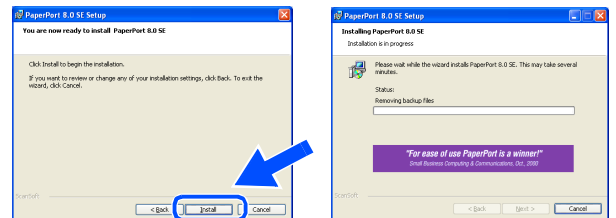

13 When the Registration screen is displayed, make your selection and follow the on screen instructions.

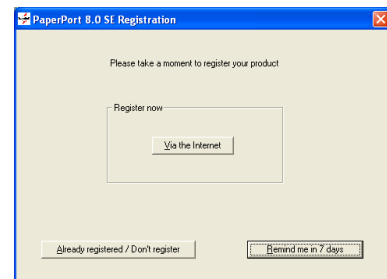

- 14 Click **Finish** to complete installation.

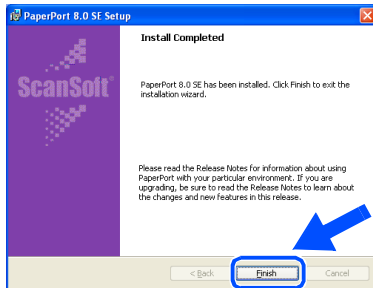

- 15 When the Brother MFC Software Suite Installation window appears, click **Next**.

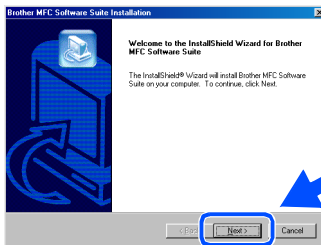

 If an error message appears during the installation process, or you have previously installed MFC Software Suite, you will first have to uninstall it. From the **Start** menu, select **Programs, Brother, Brother MFC Software Suite, Uninstall**, and then follow the instructions on the screen.

- 16 When Software License Agreement window appears, click **Yes** If you agree to it and go to next screen.

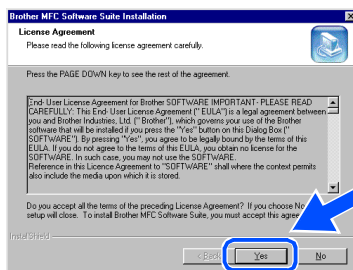

- 17 When the **Setup Type** window appears, select **Standard**, and then click **Next**.

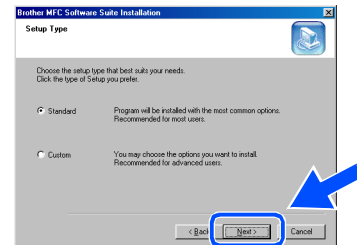

- 18 Click **Finish** restart your computer.

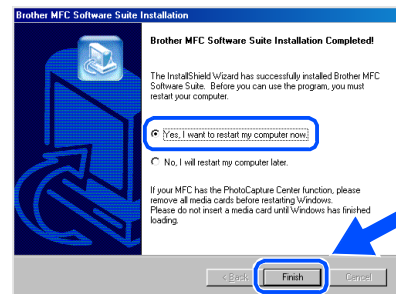

- 19 After the computer restarts, click **Yes** to have the Control Center loaded each time Windows is started. The Control Center will appear as an icon in the task tray. If you click **No** the Scan keys on the machine will be disabled.

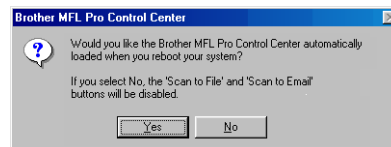

 Even if you select **NO**, later you will be able to launch the Brother Control Center to use the **Scan to** key. See "AutoLoad the Brother Control Center", Chapter 14 in the On-Line Documentation (User's Guide) on the CD-ROM.

-  **The Brother PC fax, Printer and Scanner drivers have been installed and the installation is now complete.**

Step 2

Installing the Driver & Software

For Mac[®] OS 8.5 - 9.2 Users

Make sure that you have completed the instructions from Step 1 “Setting Up the machine”.

- 1 Unplug the machine from the AC outlet and disconnect it from your Macintosh[®] if you already connected an interface cable.

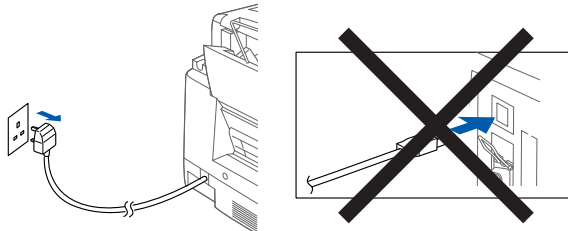

- 2 Turn on your Macintosh[®].
- 3 Insert the supplied CD-ROM into your CD-ROM drive.



- 4 Double-click the **MFC Software Suite Installer** icon to install the printer and scanner drivers.

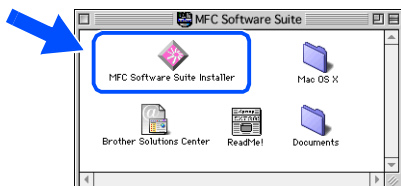

- 5 After the installation is completed, restart your Macintosh[®].

- 6 Connect the USB interface cable to your Macintosh[®], and then connect it to the machine.

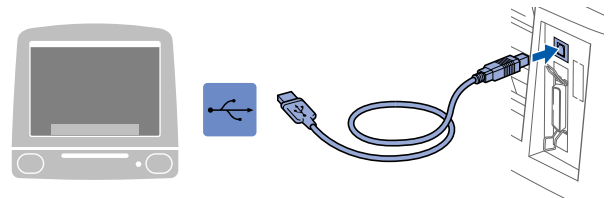

 Do not connect the machine to a USB port on a keyboard or a non powered USB hub.

- 7 Turn on the machine by plugging in the power cord.

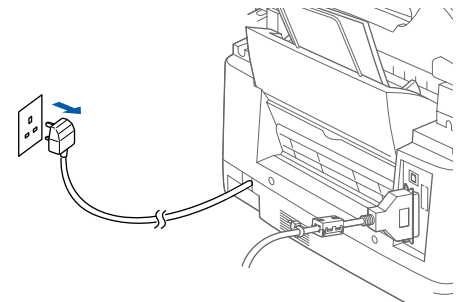

- 8 From the Apple[®] menu, open the *Chooser*.



- 9 Click the **MFL Pro Color** icon you installed. On the right side of the **Chooser**, select the printer to which you want to print. Close the **Chooser**.

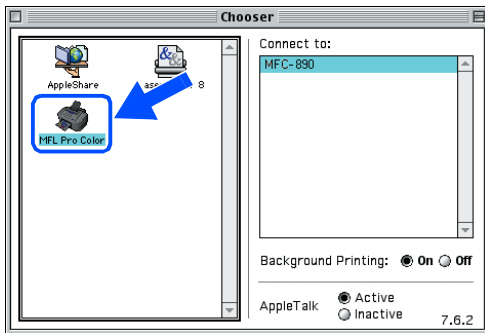

- OK! The **Brother PC fax, Printer and Scanner drivers** have been installed and the installation is now complete.

Step 2

Installing the Driver & Software

 For Mac[®] OS X 10.1, 10.2.1 or Greater Users

Make sure that you have completed the instructions from Step 1 “Setting Up the machine”.

- 1 Unplug the machine from the AC outlet and disconnect it from your Macintosh[®] if you already connected an interface cable.

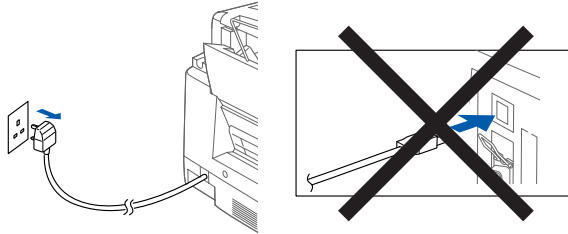

- 6 Connect the USB interface cable to your Macintosh[®], and then connect it to the machine.

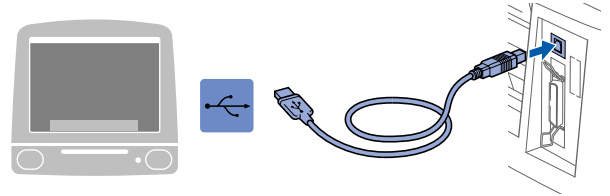

-  Do not connect the machine to a USB port on a keyboard or a non powered USB hub.

- 7 Turn on the machine by plugging in the power cord.

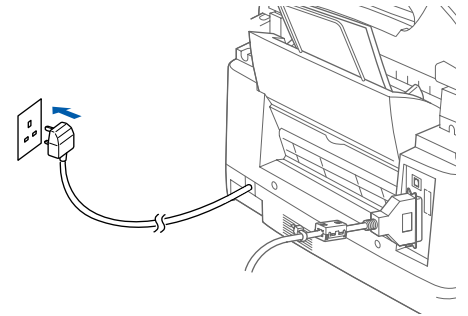

- 2 Turn on your Macintosh[®].
- 3 Insert the supplied CD-ROM into your CD-ROM drive.



- 4 Double-click the **Mac OS X** folder to install the printer driver and Remote Setup program.



- 5 Double-click the **MFL Pro_Color.pkg** icon. Follow the instructions on the screen.

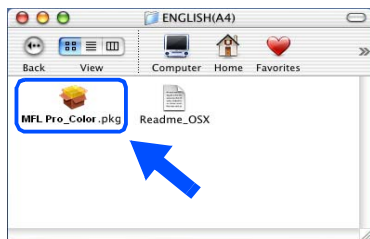

- 8 Open the **Macintosh HD** icon.

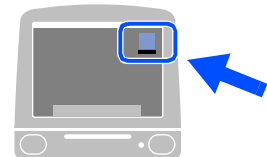

- 9 Open the **Applications** folder. Open the **Utilities** folder.

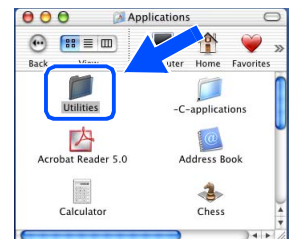
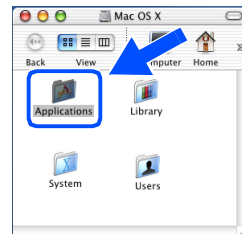

10 Open the **Printer Center** icon.

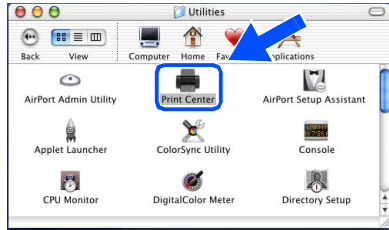

11 Click the **Add Printer...** button.

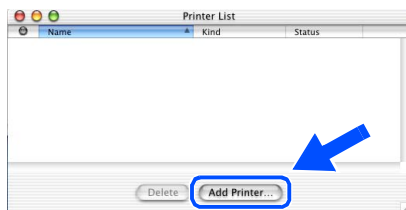

12 Select **USB**.

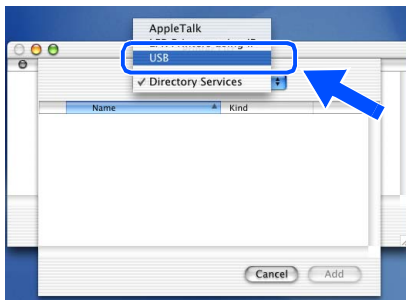

13 Select **MFC-890**, and then click the **Add** button.

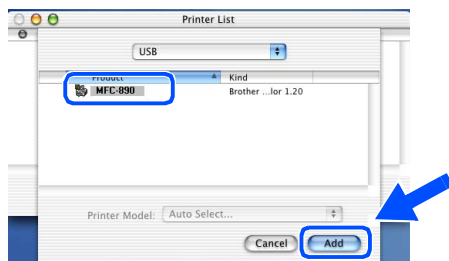

14 Select **Quit Printer Center** from the **Printer Center** menu.

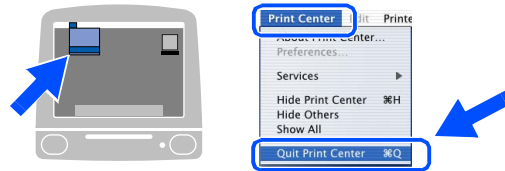

OK! The **Brother Printer, Scanner drivers** and **Remote Setup Program** have been installed and the installation is now complete.
(Scanner driver is only available for OS X 10.2.1 or greater.)

Trademarks

The Brother logo is a registered trademark of Brother Industries, Ltd.

Brother is a registered trademark of Brother Industries, Ltd.

Multi-Function Link is a registered trademark of Brother International Corporation.

PhotoCapture Center is a trademark of Brother International Corporation.

© Copyright 2002 Brother Industries, Ltd. All rights reserved.

Windows and Windows NT, Microsoft and MS-DOS are registered trademarks of Microsoft in the U.S. and other countries.

Macintosh and QuickDraw, iMac and iBook are registered trademarks of Apple Computer, Inc.

PaperPort and TextBridge are registered trademarks of ScanSoft, Inc.

Hammermill and JetPrint PHOTO are a registered trademark of International Paper.

Smart Media is a trademark of Toshiba Corporation.

Compact Flash is a trademark of SanDisk Corporation.

Memory Stick is a trademark of Sony Corporation.

Each company whose software title is mentioned in this manual has a Software License Agreement specific to its proprietary programs.

All other brand and product names mentioned in this manual are registered trademarks of their respective companies.

Compilation and Publication

Under the supervision of Brother Industries Ltd., this manual has been compiled and published, covering the latest product descriptions and specifications.

The contents of this manual and the specifications of this product are subject to change without notice.

Brother reserves the right to make changes without notice in the specifications and materials contained herein and shall not be responsible for any damages (including consequential) caused by reliance on the materials presented, including but not limited to typographical and other errors relating to the publication.

This product is designed for use in a Professional Environment.

At your side.
brother®

UK
Version A