

Xerox DocuColor 12 Digital Color Printer/Copier

System Administration Guide

The Document Company

Xerox

©1999 Xerox Corporation. All rights reserved.

Copyright protection claimed includes all forms and matters of copyrightable material and information now allowed by statutory or judicial law or hereinafter granted, including without limitation, material generated from the software programs that are displayed on the screen such as styles, templates, icons, screen displays, looks, etc.

Xerox[®], The Document Company[®], the stylized X, and all Xerox product names and product numbers mentioned in this publication are registered trademarks of Xerox Corporation. Xerox Canada is a licensee of all the trademarks. Other company brands and product names may be trademarks or registered trademarks of their respective companies and are also acknowledged.

PANTONE[®]* Colors generated by the DocuColor 12 are four-color process simulations and may not match PANTONE identified solid color standards. Use current PANTONE Color Reference Manuals for accurate color.

PANTONE Color simulations are only obtainable on this product when driven by qualified Pantone-licensed software packages. Contact Pantone, Inc. for a current list of qualified licensees.

*Pantone, Inc.'s check-standard trademark for color.

©Pantone, Inc., 1988.

Changes are periodically made to this document. Technical updates will be included in subsequent editions.

Printed in the United States of America.

Safety

The Xerox DocuColor 12 copier/printer and the recommended maintenance supplies have been designed and tested to meet strict safety requirements. Attention to the following notes will ensure the continued safe operation of your copier/printer.

Electrical safety

- Use only the power cord supplied with this equipment.
- Plug the power cord directly into a correctly grounded electrical outlet. Do *not* use an extension cord. If you do not know whether or not an outlet is grounded, consult a qualified electrician
- Do not use a ground adapter plug to connect this equipment to an electrical outlet that lacks a ground connection terminal.



WARNING: You may get a severe electrical shock if the outlet is not correctly grounded.

- Do not place the copier/printer where people may step on or trip on the power cord. Do not place objects on the power cord.
- Do not override or disable electrical or mechanical interlocks.
- Do not obstruct the ventilation openings. These openings are provided to prevent overheating of the machine.



WARNING: Never push objects of any kind into slots or openings on this equipment. Making a contact with a voltage point or shorting out a part could result in fire or electrical shock.

- If any of the following conditions occur, switch off the power to the machine immediately and disconnect the power cord from the electrical outlet. Call an authorized Xerox service representative to correct the problem.
 - The machine emits unusual noises or odors.
 - The power cord is damaged or frayed.
 - A wall panel circuit breaker, fuse, or other safety device has been tripped.
 - Liquid is spilled into the copier/printer.
 - The machine is exposed to water.
 - Any part of the machine is damaged.

Disconnect Device

The power cable is the disconnect device for this equipment. It is attached to the back of the machine as a plug-in device. To remove all electrical power from the machine, disconnect the power cable from the electrical outlet.

Laser safety



CAUTION: Use of controls, adjustments, or procedures other than those specified in this documentation may result in a hazardous exposure to laser radiation.

This equipment complies with international safety standards. With specific regard to laser safety, the equipment complies with performance standards for laser products set by government, national, and international agencies as a Class 1 laser product. It does not emit hazardous light, as the beam is totally enclosed during all phases of customer operation and maintenance.

Maintenance safety

- Do not attempt any maintenance procedure that is not specifically described in the documentation that is supplied with your copier/printer.
- Do not use aerosol cleaners. The use of supplies that are not approved may cause poor performance of the copier/printer, and could create a dangerous condition.
- Use the supplies and cleaning materials only as directed in this manual. Keep all of these materials out of the reach of children.
- Do not remove the covers or guards that are fastened with screws. There are no parts behind these covers that you can maintain or service.

Do not perform any maintenance procedures unless you have been trained to do them by a Xerox representative or unless a procedure is specifically described in one of the copier/printer manuals.

Operational safety

Your Xerox equipment and supplies were designed and tested to meet strict safety requirements. These include safety agency examination, approval, and compliance with established environmental standards.

Your attention to the following safety guidelines will help ensure the continued safe operation of your copier/printer:

- Use the materials and supplies specifically designed for your copier/printer. The use of unsuitable materials may result in poor performance of the machine and possibly a hazardous situation.
- Follow all warnings and instructions that are marked on or supplied with the machine.
- Place the machine in a room that provides adequate space for ventilation and servicing.
- Place the machine on a level, solid surface (not on a thick pile carpet) that has adequate strength to support the weight of the machine.
- Do not attempt to move the machine. A leveling device that was lowered when your machine was installed may damage the carpet or floor.
- Do not locate the machine near a heat source.
- Do not locate the machine in direct sunlight.

- Do not locate the machine in line with the cold air flow from an air conditioning system.
- Do not place containers of coffee or other liquid on the machine.
- Do not block or cover the slots and openings on the machine. Without adequate ventilation, the machine may overheat.
- Do not attempt to override any electrical or mechanical interlock devices.



WARNING: Be careful when working in areas identified with this warning symbol. These areas may be very hot and could cause personal injury.

If you need any additional safety information concerning the machine or materials, contact your Xerox representative.

Ozone safety

This product produces ozone during normal operation. The ozone is heavier than air, and the quantity is dependent on copy volume. Providing the correct environmental parameters, as specified in the Xerox installation procedures, ensures that concentration levels meet safe limits.

If you need additional information about ozone, request the Xerox publication, *OZONE*, 600P83222, by calling 1-800-828-6571 in the USA. For a French language version, call 1-800-828-6571 in the USA, then press 2.

Radio Frequency Emissions

FCC

This equipment has been tested and found to comply with the limits for a Class B digital device, pursuant to Part 15 of the FCC Rules. These limits are designed to provide reasonable protection against harmful interference in a residential installation. This equipment generates, uses, and can radiate radio frequency energy and, if not installed and used in accordance with the instructions, may cause harmful interference to radio communications. However, there is no guarantee that interference will not occur in a particular installation. If this equipment does cause harmful interference to radio or television reception, which can be determined by turning the equipment off and on, the user is encouraged to try to correct the interference by one or more of the following measures:

- Reorient or relocate the receiving antenna.
- Increase the separation between the equipment and receiver.
- Connect the equipment into an outlet on a circuit different from that to which the receiver is connected.
- Consult the dealer or an experienced radio/TV technician for help.

Changes or modifications to this equipment not specifically approved by the Xerox Corporation may void the authority granted by the FCC to operate this equipment.

Shielded cables must be used with this equipment to maintain compliance with FCC regulations.

In Canada

This digital apparatus does not exceed the Class B limits for radio noise emissions from digital apparatus as defined in the Radio interference regulations of Industry Canada.

FCC

The following applies to the product when equipped with the Token Ring or Banyan Vines connectivity options:

This equipment has been tested and found to comply with the limits for a Class A digital device, pursuant to Part 15 of the FCC Rules. These limits are designed to provide reasonable protection against harmful interference when the equipment is operated in a commercial environment. This equipment generates, uses, and can radiate radio frequency energy and, if not installed and used in accordance with the instruction manual, may cause harmful interference to radio communications. Operation of this equipment in a residential area is likely to cause harmful interference in which case the user will be required to correct the interference at his/her own expense.

Changes or modifications to this equipment not specifically approved by the Xerox Corporation may void the user's authority to operate this equipment.

Shielded cables must be used with this equipment to maintain compliance with FCC regulations.

In Canada

This digital apparatus does not exceed the Class A limits for radio noise emissions from digital apparatus as defined in the Radio interference regulations of Industry Canada.

Safety Extra Low Voltage Approval

The Xerox DocuColor 12 copier/printer is in compliance with various governmental agencies and national safety regulations. All system ports meet the Safety Extra Low Voltage (SELV) circuits for connection to customer-owned devices and networks. Additions of customer-owned or third-party accessories that are attached to the copier/printer must meet or exceed the requirements listed above. All modules that require external connection must be installed per the DocuColor 12 installation procedure.

Certifications . . . in Europe



The CE marking that is applied to this product symbolizes Xerox Europe's Declaration of Conformity with the following applicable Directives of the European Union as of the dates indicated:

January 1, 1995: - Council Directive 73/23/EEC amended by Council Directive 93/68/EEC, approximation of the laws of the member states related to low voltage equipment.

January 1, 1996: - Council Directive 89/336/EEC, approximation of the laws of the member states related to electromagnetic compatibility.

Changes or modifications to this equipment not specifically approved by Xerox Europe may void the user's authority to operate the equipment.

Shielded cables must be used with this equipment to maintain compliance with the EMC Directive 89/336/EEC.

This equipment is not primarily intended for use in a domestic environment.

A full declaration, defining the relevant Directives and referenced standards, can be obtained from your Xerox Europe representative.



WARNING: In order to allow this equipment to operate in proximity to Industrial, Scientific and Medical (ISM) equipment, the external radiation from ISM equipment may have to be limited or special mitigation measures taken.

The following applies to the product when equipped with Token Ring or Banyan Vines connectivity options:



WARNING: This is a Class A product. In a domestic environment, this product may cause radio interference, in which case the user may be required to take adequate measures.

Changes or modifications to this equipment not specifically approved by Xerox Europe may void the user's authority to operate the equipment.

Shielded cables must be used with this equipment to maintain compliance with the EMC Directive 89/336/EEC.



WARNING: In order to allow this equipment to operate in proximity to Industrial, Scientific and Medical (ISM) equipment, the external radiation from ISM equipment may have to be limited or special mitigation measures taken.

It's Illegal . . . in the USA

Congress, by statute, has forbidden the copying of the following subjects under certain circumstances. Penalties of fine or imprisonment may be imposed on those guilty of making such copies.

1. Obligations or Securities of the United States Government, such as:

Certificates of Indebtedness National Bank Currency

Coupons from Bonds Federal Reserve Bank Notes

Silver Certificates Gold Certificates

United States Bonds Treasury Notes

Federal Reserve Notes Fractional Notes

Certificates of Deposit Paper Money

Bonds and Obligations of certain agencies of the government, such as FHA, etc.

Bonds. (U.S. Savings Bonds may be photographed only for publicity purposes in connection with the campaign for the sale of such bonds.)

Internal Revenue Stamps. (If necessary to copy a legal document on which there is a canceled revenue stamp, this may be done, provided the reproduction of the document is performed for legal purposes.)

Postage Stamps, canceled or uncanceled. (For philatelic purposes, Postage Stamps may be photographed, provided the reproduction is in black and white and is less than 75% or more than 150% of the linear dimensions of the original.)

Postal Money Orders.

Bills, Checks, or Drafts of money drawn by or upon authorized officers of the United States.

Stamps and other representatives of value, of whatever denomination, which have been or may be issued under any Act of Congress.

2. Adjusted Compensation Certificates for Veterans of the World Wars.
3. Obligations or Securities of any Foreign Government, Bank, or Corporation.
4. Copyrighted material, unless permission of the copyright owner has been obtained or the copying falls within the "fair use" or library reproduction rights provisions of the copyright law. Further information of these provisions may be obtained from the Copyright Office, Library of Congress, Washington, D.C. 20559. Ask for Circular R21.
5. Certificates of Citizenship or Naturalization. (Foreign Naturalization Certificates may be photographed.)
6. Passports. (Foreign Passports may be photographed.)
7. Immigration Papers.
8. Draft Registration Cards.
9. Selective Service Induction Papers that bear any of the following Registrant's information:
Earnings or Income Dependency Status
Court Record Previous military service
Physical or mental condition

Exception: U.S. Army and Navy discharge certificates may be photographed.
10. Badges, Identification Cards, Passes, or Insignia carried by Military or Naval personnel, or by members of the various Federal Departments, such as FBI, Treasury, etc. (unless photograph is ordered by the head of such department or bureau.)

Copying the following is also prohibited in certain states:

Automobile Licenses - Drivers' Licenses -
Automobile Certificates of Title.

The above list is not all inclusive, and no liability is assumed for its completeness or accuracy. In case of doubt, consult your attorney.

It's Illegal . . . in Canada

Parliament, by statute, has forbidden the copying of the following subjects under certain circumstances. Penalties of fines or imprisonment may be imposed on those guilty of making such copies.

1. Current bank notes or current paper money.
2. Obligations or securities of a government or bank.
3. Exchequer bill paper or revenue paper.
4. The public seal of Canada or of a province, or the seal of a public body or authority in Canada, or of a court of law.
5. Proclamations, orders, regulations or appointments, or notices thereof (with intent to falsely cause same to purport to have been printed by the Queen's Printer for Canada, or the equivalent printer for a province).
6. Marks, brands, seals, wrappers or designs used by or on behalf of the Government of Canada or of a province, the government of a state other than Canada or a department, board, Commission or agency established by the Government of Canada or of a province or of a government of a state other than Canada.
7. Impressed or adhesive stamps used for the purpose of revenue by the Government of Canada or of a province or by the government of a state other than Canada.
8. Documents, registers or records kept by public officials charged with the duty of making or issuing certified copies thereof, where the copy falsely purports to be a certified copy thereof.
9. Copyrighted material or trademarks of any manner or kind without the consent of the copyright or trademark owner.
10. The above list is provided for your convenience and assistance, but it is not all inclusive, and no liability is assumed for its completeness or accuracy. In case of doubt, consult your solicitor.

Environmental Notices . . . in the USA



As an ENERGY STAR® partner, Xerox Corporation has determined that this copier/printer model meets the ENERGY STAR® guidelines for energy efficiency.

ENERGY STAR® is a US registered trademark.

The ENERGY STAR program is a team effort between the Environment Protection Agency and the office equipment industry to promote energy-efficient personal computers, monitors, printers, fax machines and copiers. Reducing the energy consumption of this equipment will help combat smog, acid rain and long-term changes to the climate by decreasing the emissions that result from generating electricity.

Environmental Notices . . . in Canada



As a participant in the Environmental Choice program, Xerox Corporation has determined that this copier/printer model meets the Environmental Choice guidelines for energy efficiency.

Environment Canada established the Environmental Choice program in 1988 to help consumers identify environmentally responsible products and services. Copier, printer and fax products must meet energy efficiency and emissions criteria, and exhibit compatibility with recycled supplies. Currently, Environmental Choice has more than 1600 approved products and 140 licensees. Xerox has been a leader in offering EcoLogo approved products. In 1996, Xerox became the first company licensed to use the Environmental Choice EcoLogo for its copiers, printers, and fax machines.

Contents

Safety Notes	I
Electrical safety	I
Laser safety	III
Maintenance safety	IV
Operational safety	V
Ozone safety	VI
Notices	VII
Radio Frequency Emissions	VII
FCC	VIII
In Canada	VIII
FCC	VIII
In Canada	VIII
Safety Extra Low Voltage Approval	IX
Certifications . . . in Europe	X
It's Illegal . . . in the USA	XII
It's Illegal . . . in Canada	XIV
Environmental Notices . . . in the USA	XV
Environmental Notices . . . in Canada	XVI
1. About this manual	1-1
Conventions used in this manual	1-2
2. Managing counts and accounts	2-1
Overview	2-1
Meter Check	2-2
Confirm Consumables	2-3
Auditron Administration mode	2-4
Entering the Auditron Administration mode	2-5
Exiting the Auditron Administration mode	2-6
Create/Modify User Accounts	2-7
Edit Accounts	2-8
Reset Accounts	2-10
Auditron Access	2-11
Change of Auditron Administrator Password . . .	2-12

3. Tools Mode	3-1
Overview	3-1
Entering and Exiting Tools Mode	3-3
Entering Tools Mode	3-3
Exiting Tools Mode	3-4
Tray Management	3-5
Paper Type	3-5
Auto Tray Setup	3-7
Feature Defaults	3-9
Basic procedure for setting Feature Defaults . . .	3-10
Paper Supply	3-11
Reduce/Enlarge	3-11
Original Type	3-12
Photo Type – Photo & Text	3-13
Photo Type – Photo Type	3-14
Text Type	3-15
Lighten/Darken	3-16
Output Color	3-16
Color Shift	3-17
Saturation	3-17
Variable Color Balance (Yellow, Magenta, Cyan, Black)	3-18
Sharpness	3-19
Margin Shifts for Side 1 and Side 2	3-20
Corner Shift	3-21
Variable Shift	3-21
Edge Erase	3-22
Original Orientation	3-23
2 Sided Copy	3-23
Side 2 Rotate	3-23
Multiple-Up	3-24
2 Pages Up	3-24
4 & 8 Pages Up	3-24
Machine Set-up	3-25
Audio Tones	3-27
Customize Screens	3-29
System Image Quality	3-31
Adjusting Image Recognition settings	3-32
Auto Screening Adjust	3-34
Machine Timeouts	3-36
Reduce/Enlarge Defaults	3-38
Change Tools Access Number	3-40
Original Size Presets	3-41

4. Maintenance	4-1
Overview	4-1
Cleaning the Touch Screen	4-2
Cleaning the Document Glass	4-3
Cleaning the Document Glass Cover	4-4
Cleaning the Edit Pad	4-5
Supply replacement	4-6
Replacing the Dry Ink Cartridge	4-6
Replacing the Dry Ink Waste Container	4-9
Replacing the Developer Waste Container	4-12
Replacing the Copy/Print Cartridge	4-15
Replacing the Fuser Oil Cartridge	4-19
Replacing the Cleaning Web	4-24
Calling for Service	4-27
Ordering supplies	4-29
Supplies to keep on hand	4-30
Recommended papers and transparencies	4-31
Replacement Manuals (USA market only)	4-31

1. About this manual

The System Administration screens enable the system administrator to check meters, consumables, and output counts. It also enables the system administrator to access the Tools Mode.

In the Tools Mode, the System Administrator can set the default values for a variety of copy output and copier/printer features, register custom colors, and relocate/add or delete features from screens.

Finally, the System Administrator is generally the one person trained to perform maintenance tasks, order supplies, and perform removal/replacement procedures.

The System Administration guide therefore is divided into three parts:

- Checking meters, consumables, and output counts
- Tools mode
- Maintenance

This guide should be used in conjunction with the *DocuColor 12 User Guide* and the *Recommended Materials for the DocuColor 12*. For more information about the DocuColor 12 with External Digital Front End (DFE), refer to the *DocuColor 12 Printer User Guide*.

For planning information, refer to the *DocuColor 12 Customer Site Planning Guide*.

Conventions used in this manual

Descriptions of features and options generally precede procedure steps. You may need to combine several procedures to achieve desired results.

This manual uses a number of symbols to help you identify various kinds of information. These symbols are described below.



The 1, 2, 3 symbol indicates the beginning of a procedure. Be sure to follow steps carefully in the order given.



NOTE: Notes provide extra information that may be helpful to your understanding or performance of procedures.



KEY POINT: The key symbol draws your attention to important additional information, hints, or tips.



WARNING: This symbol alerts you to an operating or maintenance procedure, practice, or condition, that, if not strictly observed, could result in injury or loss of life.



WARNING: This Hot Surface symbol warns you of an area that may be very hot and would cause personal injury if touched.



CAUTION: This symbol alerts you to an operating or maintenance procedure, practice, or condition that, if not strictly observed, could result in damage to or destruction of equipment or loss of data.

2. Managing counts and accounts

Overview

The System Administrator is responsible for periodically checking the current counts for output and consumables such as dry ink or fuser oil. Any user can check these counts.

The System Administrator also confirms and edits accounts, and has the option to delete accounts or change the system administration password.

Use the Administration button, illustrated in Figure 1, above the numeric keypad and the procedures in this chapter to perform these activities.



Figure 1: Administration button

Meter Check

With the Meter Check feature, any user can check the current copy volume for black and white, full-color, three-color, or single color copies.

2

1 2 3...

- 1 Press the **Administration** button above the numeric keypad to display the Access screen, as illustrated in Figure 2.



Figure 2: Access screen

- 2 Touch the **Meters** icon to display the Meters screen, as illustrated in Figure 3.
- 3 Note the current counts for the various document types.
- 4 Touch **Close** to display the Access screen.
- 5 Touch **Close** to exit Administration mode and display the operator tabs.

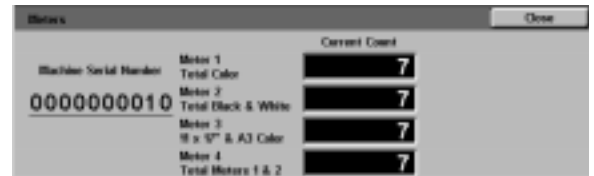

Figure 3: Meters screen

Confirm Consumables

With the Confirm Consumables feature, any user can check the state of DocuColor 12 consumables to determine whether any of them needs replacing.

1 2 3...

- 1 Press the **Administration** button above the numeric keypad to display the Access screen, as illustrated in Figure 4.
- 2 Touch the **Consumables Status** icon to display the Consumables Status screen, as illustrated in Figure 5.
- 3 Note the current state for the various consumables. "OK" indicates no replacement is necessary.
- 4 Touch **Close** to display the Access screen.
- 5 Touch **Close** to exit Administration mode and display the operator tabs.



Figure 4: Access screen



Figure 5: Consumables Status screen

Auditron Administration mode

When enabled, the Auditron Administration mode keeps a count of the copy volume for each registered account.

The System Administrator can perform the following tasks in the Auditron Administration Mode:

- Create/Modify User Accounts
- Auditron Access
- Edit Accounts
- Reset Accounts
- Auditron Administrator Password



NOTE: To access any of the screens on which you perform these functions, you must first enter the System Administrator password.

This section leads you through the procedures for entering and exiting Auditron Administration mode and for the tasks described above.

Entering the Auditron Administration mode

1 2 3...

- 1 Press the Administration button above the numeric keypad to display the Access screen.
- 2 Touch the **Auditron Administration** button on the screen to display the Enter Password screen, as illustrated in Figure 6.

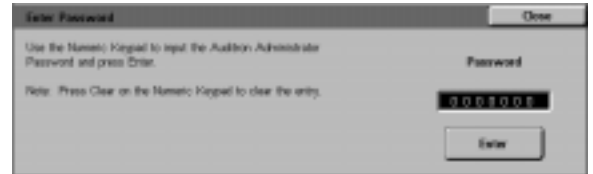

Figure 6: Enter Password screen

- 3 Use the numeric keypad to enter the correct password and touch **Enter** on the Touch Screen to display the Auditron Administration screen, as illustrated in Figure 7.



NOTE: The default password is 11111. Be sure to change the password so that unauthorized individuals do not have access to the Auditron Administration mode.

To close the window without entering a password, touch **Close**.



Figure 7: Auditron Administration screen



KEY POINT:

- All previous programming selections are canceled when you press the **Clear All** button in the Auditoron Administration mode.
- You cannot program jobs while in the Auditoron Administration mode.

2

Exiting the Auditoron Administration mode

1 2 3...

To exit the Auditoron Administration mode, touch the **Close** button on the Auditoron Administration screen.



Touch **Close** to exit any screen within the Auditoron Administration mode without making changes and to display the previous screen.

Create/Modify User Accounts

Use the Create/Modify User Accounts feature to create user accounts for count administration purposes



KEY POINT: You must create an account before you edit (enter or change) its password, account limit, or restrictions.

1 2 3...

- 1 On the Auditron Administration screen, touch **Create/Modify User Accounts** to display the Create/Modify User Accounts screen, as illustrated in Figure 8.
- 2 Perform one of the following:
 - Use the **up** and **down** arrows to enter a new account number.
 - Touch the **Input Number With Keypad** button and type in the new account number using the keypad.
Touch the **Enter** button.
- 3 Touch **Close** to display the Auditron Administration screen.



Figure 8: Create/Modify User Accounts screen

Edit Accounts

Use the Edit Accounts feature to change settings or reset the counter for an account that was previously created.

KEY POINT: You must create an account before you edit (enter or change) its password, account limit, or restrictions.



2

1 2 3...

- 1 On the Auditor Administration screen, touch **Edit Accounts** to display the Edit Accounts screen, as illustrated in Figure 9.
- 2 Touch the **Input Number with Keypad** button and type in an account number for an existing account using the keypad.
Touch the **Enter** button.
- 3 Touch the **Change Settings: Account ####** icon to display the Change Settings screen.



Figure 9: Edit Accounts screen

4 Perform one or more of the following:

- Enter the Account Password.
Under the Account Password box, touch the **Input Number with Keypad** button.

Type in a password for the account. The password must be at least four digits long.

Touch the **Enter** button. The password is displayed.

- Enter the Account Limit.
Under the Account Limit box, touch the **Input Number with Keypad** button.

Touch the **Enter** button. The account limit is displayed.

- Assign Restrictions.
Touch the appropriate button to indicate whether the account has **No Restrictions**, can make **Color Only** copies, or can make **Black & White Only** copies.

5 Touch **Close** to display the Edit Accounts screen.

View the settings for the password, account limit, and restrictions. If necessary, repeat step 3 to change the values.

6 If you want to reset the number of Total Copies for the account to zero, touch the **Reset Counter** button.

7 Repeat steps 2-5 for other accounts.

8 Touch **Close** to display the Auditor Administration screen.



Figure 10: Change Settings screen

Reset Accounts

Use the Reset Accounts feature to delete current accounts, reset copy counts to zero, disable copy limits, or remove color restrictions.

2

1 2 3...

- 1 On the Auditor Administration screen, touch **Reset Accounts** to display the Reset Accounts screen, as illustrated in Figure 11.
- 2 Perform one of the following:
 - To delete all current Auditor accounts, touch **Delete All Accounts**.
 - To reset current copy counts for all accounts to zero, touch **Reset Copy Counters**.
 - To remove copy count limits, touch **Disable All Copy Limits**.
 - To remove color restrictions, enabling both Black & White and Color copying and printing for all users, touch **Remove Color Restrictions**.

A confirmation screen displays.

- 3 Perform one of the following:
 - To confirm the action, touch **Yes**.
 - To cancel the action, touch **No**.The Reset Accounts screen displays.
- 4 Touch **Close** to display the Auditor Administration screen.



Figure 11: Reset Accounts screen

Auditron Access

Use the Auditron Access feature to enable the Auditron feature, which tracks current copy counts, copy limits, color limits, or accounts. You can also set User Account Timeouts from the Auditron Access screen.



KEY POINT: When the Auditron is enabled, users must enter passwords in order to use the copier. Therefore, the System Administrator must ensure that at least one account is created and assigned a password. Otherwise, the Administration screens are accessible and the general user screens are inaccessible.

1 2 3...

- 1 On the Auditron Administration screen, touch **Auditron Access** to display the Auditron Access screen, as illustrated in Figure 12.
- 2 Perform one of the following:
 - To use the Auditron feature, touch the **Enabled** button.
 - To exit the Auditron feature, touch the **Disabled** button.
 - To set a timeout for user accounts, touch the **User Account Timeout** icon to display the User Accounts Timeout screen, as illustrated in Figure 13. Perform one of the following:
 - Use the **up** and **down** arrows to set the timeout (from 1 second to 10 minutes)
 - Touch the **Disable** icon to remove any timeout restrictions.

Touch **Save** to display the Auditron Access screen.
- 3 Touch **Save** to display the Auditron Administration screen.



Figure 12: Auditron Access screen



Figure 13: User Accounts Timeout screen

Change of Auditron Administrator Password

Use the Auditron Administrator Password feature to change the password used by the System or Auditron Administrator to enter Auditron Administration and Tools modes.

2

1 2 3...

1 On the Auditron Administration screen, touch **Auditron Administrator Password** to display the Auditron Administrator Password screen, as illustrated in Figure 14.

2 Enter a value from the numeric keypad into the New password box. Press the **Enter** button.

3 Enter the same number in the Confirm password box. Press the **Enter** button.



NOTE: If you make a mistake in entering a value, press **Reset**, type the number again, and press the **Enter** button.

4 Touch **Close** to display the Auditron Administration screen.

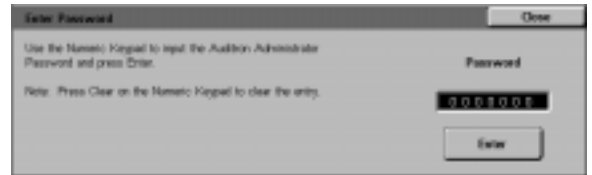

Figure 14: Auditron Administrator Password screen

3. Tools Mode

Overview

In the Tools Mode, the system administrator can set the default values for a variety of copy output and copier/printer features, or register custom colors.

The Tools screen, illustrated in Figure 1, is displayed when you enter the Tools Mode. From this screen, you can access and change options for the following features:

- Tray Management
- Feature Defaults
- Machine Set-up
- Audio Tones
- Customize Screens
- System Image Quality
- Machine Timeouts
- Reduce/Enlarge Defaults
- Change Tools Access Number
- Original Size Presets



Figure 1: Tools screen

This chapter helps you enter and exit Tools Mode, and provides information and procedures for each of the features listed above to help you customize the DocuColor 12.



KEY POINT: Touch **Close** on the Tools screen to return to the operator tabs.

Entering and Exiting Tools Mode

Entering Tools Mode



KEY POINT:

- All previous programming selections are canceled when you press the **Clear All** button in the Tools Mode.
- You cannot program jobs while in the Tools Mode.

1 2 3...

- 1 Press the Administration button (Figure 2) above the numeric keypad to display the Access screen, illustrated in Figure 3.



Figure 2: Administration symbol



Figure 3: Access screen

- 2 Touch the **Tools** button to display the Tools Access Number screen, as illustrated in Figure 4.



Figure 4: Tools Access Number screen

3

- 3 Use the numeric keypad to enter the correct password and touch **Enter** on the Touch Screen.



NOTE: The default password is 11111. Be sure to change the password so that unauthorized individuals do not have access to Tools Mode.

To close the window without entering a password, touch **Close**.

After you have entered the correct password, the Tools screen displays, as illustrated in Figure 5.



Figure 5: Tools screen

Exiting Tools Mode

1 2 3...

To exit the Tools Mode, touch the **Close** button on the System Administration Items screen.



Touch **Close** to exit any screen within Tools Mode without making changes and to display the previous screen.

Tray Management

The Tray Management screen displays the Paper Type and Auto Tray Setup features.

Paper Type

The Paper Type screen displays Paper Trays 1, 2, 3 and 4 and the current type of stock (normal, heavyweight, or transparency separators) that is in each tray.

NOTE: Do not run heavyweight paper from Paper Tray 1.



1 2 3...

- 1 On the Tools screen, touch the **Tray Management** icon to display the Tray Management screen, as illustrated in Figure 6.



Figure 6: Tray Management screen

- 2 Touch the **Paper Type** icon to display the Paper Type screen, as illustrated in Figure 7.



Figure 7: Paper Type screen

3

- 3 Review the current settings for each tray. Use the up and down arrows to highlight the desired paper tray and touch the **Change Settings** button to display the detail screen for the tray. A sample detail screen for Trays 2, 3, and 4 is illustrated in Figure 8.



NOTE:

- You can not run heavyweight paper from Paper Tray 1. The only option on the Tray 1 detail screen is Normal.
- The Auto Tray Setup - Switching option, set through Auto Paper Select, must be disabled before you can select the Heavyweight option for Trays 2, 3, or 4.



Figure 8: Sample Tray detail screen

3

- 4 Touch the button for the setting that best describes the paper type for the tray.
- 5 Touch **Save** to display the Paper Type screen.
- 6 If necessary, repeat steps 3 through 5 for another paper tray.
- 7 Touch **Close** to display the Tray Management screen.
- 8 Touch **Close** to display the Tools screen.

Auto Tray Setup

Touching **Auto Tray Setup** on the Tray Management screen displays the Auto Tray Setup screen.

On this screen, you can enable Auto Tray Switching for Paper Trays 1, 2, 3, and 4.

Enabling Auto Tray Switching allows the copier/printer to switch automatically to another tray with the same size and type of paper when the first tray runs out of paper.



NOTE: To enable Auto Tray Switching, ensure that more than one tray is configured for the same size paper and feeding orientation (long edge feed or short edge feed).

1 2 3...

- 1 On the Tools screen, touch the **Tray Management** icon to display the Tray Management screen, as illustrated in Figure 9.



Figure 9: Tray Management screen

- 2 Touch the **Auto Tray Setup** icon to display the Auto Tray Setup screen, as illustrated in Figure 10.

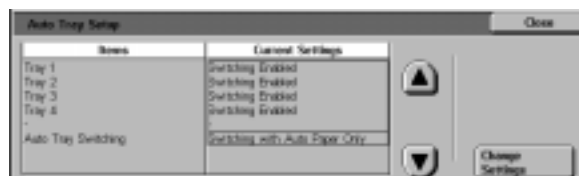

Figure 10: Auto Tray Setup screen

- 3 Review the current settings for each tray and the Auto Tray Switching option.
- 4 To enable or disable Auto Tray Switching, use the up and down arrows to highlight the desired paper tray, and touch the **Change Settings** button to display the tray detail screen, as illustrated in Figure 11.

Touch **Enable Auto Paper** or **Disable Auto Paper**.

- 5 Touch **Save** to display the Auto Tray Setup screen.

If necessary, repeat steps 3 and 4 for another paper tray.

- 6 To enable or disable Auto Tray switching, use the up and down arrows to highlight the Auto Tray Switching option. Touch the **Change Settings** button to display the Auto Tray Switching screen, as illustrated in Figure 12.

Touch **Switching Enabled**, **Switch-Auto Paper Only**, or **Switching Disabled**.

- 7 Touch **Save** to return to the Auto Tray Setup screen.
- 8 Touch **Close** to display the Tray Management screen.
- 9 Touch **Close** to display the Tools screen.



Figure 11: Sample Tray detail screen

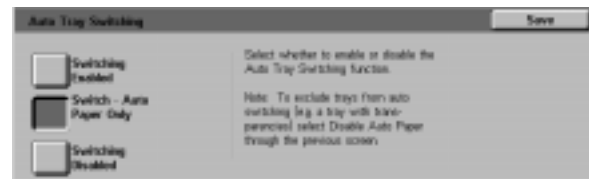

Figure 12: Auto Tray Switching screen

3

Feature Defaults

The Feature Defaults options enable you to change factory default settings for a number of features, including Paper Supply, Reduce/Enlarge, Original Type, Image Quality Settings, Margin Shift, Edge Erase, Original Orientation, 2 Sided Copy, and Multiple-Up. The first Feature Defaults screen is illustrated in Figure 13

Because these procedures are very similar, use the basic procedure that follows to set new defaults. Any differences are noted in the descriptions provided for each default and its settings.

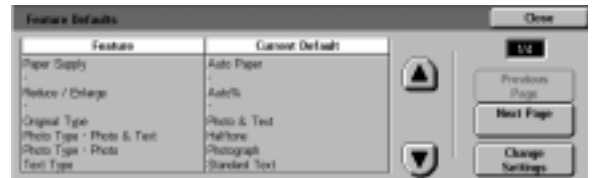

**Figure 13: Feature Defaults screen
(page 1 of 4)**

Basic procedure for setting Feature Defaults

1 2 3...

- 1 On the Tools screen, touch the **Feature Defaults** icon to display the Feature Defaults screen, as illustrated in Figure 14.
- 2 Review feature default items and their current settings.

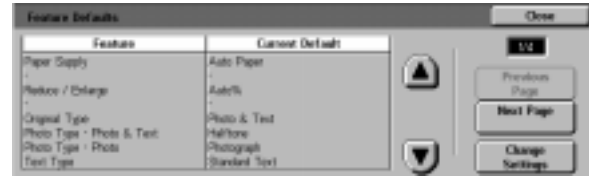

Figure 14: Feature Defaults screen

KEY POINT: There are multiple screens or pages for Feature Defaults. The numbers in the box at the top right of the screen indicate which Feature Defaults screen you are viewing and the total number of screens. For example, 1/4 indicates you are viewing the first of four Feature Defaults screens.



3

- 3 To display items on other screens, touch the **Next Page** button or **Previous Page** button.
- 3 To change the current setting of a feature, use the up and down arrows to highlight the desired feature.
Touch the **Change Settings** button to display the feature detail screen.
- 4 Touch the button for the desired default.
- 5 Touch **Save** to display the Feature Defaults screen.
- 6 If necessary, select another feature and change its settings using steps 2-5. Refer to the sections that follow for more information about individual features.
- 7 Touch **Close** to display the Tools screen.

Paper Supply

This option allows you to designate the default paper tray. Selecting **Auto** (Figure 15) enables the copier/printer to determine the paper tray to use based on the size of the original document.



Figure 15: Paper Tray Default screen

Reduce/Enlarge

This option allows you to designate the default reduction or enlargement. Selecting **Auto** enables the copier/printer to determine the reduction or enlargement percentage to use based on the size of the original document and the selected paper tray.



Figure 16: Reduce/Enlarge screen

The selected value is displayed in the percentage box of the Reduce/Enlarge screen, as illustrated in Figure 16.

NOTE: Auto% cannot be used with Auto Paper Supply.



Original Type

This option allows you to set the original type for the majority of the original documents you will be copying or printing. Based on your selection, the copier/printer automatically makes fine adjustments to optimize the copy sharpness based on the type of original selected. As illustrated in Figure 17, original types include:

- **Photo & Text** — Most original documents consist of both text and graphics.
- **Text** — Most original documents consist of words with few detailed graphics.
- **Photo** — Most original documents contain halftones or photographs.
- **Graphics & Maps** — Most original documents contain intricate drawings that require a number of details to be copied with utmost precision.

If you select one of the first three options, you should also select the detail for that original type using the appropriate Original Type screens that follow this option.



Figure 17: Original Type screen

Photo Type – Photo & Text

Photo Type–Photo & Text is the best selection for original documents that contain pictures and printed text, such as magazines or professional journals with pictures and text.

Output copies are made using the sharpness and density levels that combine the best levels for picture, chart, and text areas to provide optimum image quality.

As illustrated in Figure 18, this option allows you to specify the default for the kind of photograph or picture originals you will be copying.

- **Halftone** — Use this option when most original documents will be images that are created using a fine screen that varies the darkness and density of dots that make up the image. Examples of halftone images can be found in magazines and newspapers.
- **Photograph** — Use this option when most original documents will be photographs or extremely fine halftones.
- **Xerographic Copy** — Use this option when most jobs will use a xerographic reproduction (copy) as the original document.

The Photo & Text option applies the best sharpness and density levels automatically for optimum color quality on all color copies



Figure 18: Photo Type–Photo & Text screen

Photo Type – Photo Type

The Photo Type–Photo Type option is the best selection for photographs, lithographs, or graphics that contain a variety of pastel colors.

This option provides the following advantages:

- The most accurate color and density copy for continuous tone documents that contain a wide range of densities from very dark to very light images
- The best selection when true reproduction of light skin colors, light colors, or gray areas is important
- The best option for very high quality halftone documents.

As illustrated in Figure 19, this option allows you to specify the default for the kind of Photo originals you will be copying.

- **Halftone** — Use this option when most original documents will be images that are created using a fine screen that varies the darkness and density of dots that make up the image. Examples of halftone images can be found in magazines and newspapers.
- **Photograph** — Use this option when most original documents will be photographs or extremely fine halftones.
- **Xerographic Copy** — Use this option when most jobs will use a xerographic reproduction (copy) as the original document.



Figure 19: Photo Type–Photo Type screen

Text Type

The Text Type option is the best selection for documents composed of fine line characters or other high contrast documents with bright, dense colors. For documents in which priority is given to the text, this selection produces the clearest output text. Selecting this option suppresses background color.

As illustrated in Figure 20, this option allows you to specify the default for the kind of text originals you will be copying.

- **Standard Text** — Most original documents will be of standard darkness.
- **Light Text** — Most original documents will be lighter than normal or consist of lines that vary in thickness and darkness, such as those that are written in pencil.



Figure 20: Text Type screen

Lighten/Darken

The Lighten/Darken feature enables you to adjust the overall lightness or darkness (density) of the output copy.

Select darker settings for light originals and light settings for dark originals, as illustrated in Figure 21.

Selecting Auto Contrast enables the copier/printer to determine the lightness or darkness to use based on its scan of the original document.



Figure 21: Lighten/Darken screen

Output Color

The Output Color option allows you to set the default to Auto Color, Full Color (using Black, Yellow, Cyan and Magenta), 3 Pass Color (using Yellow, Cyan and Magenta), or Black, as illustrated in Figure 22.

Selecting Auto Color enables the copier/printer to determine the output color to use based on its scan of the original document.



Figure 22: Output Color screen

Color Shift

This option allows you to shift the output color from blue (coolest) to red (warmest), as illustrated in Figure 23.

If you select a shift toward red (a warm color), the red colors shift towards the yellow hue, the green colors towards the cyan hue, and the blue colors towards the magenta hue. The lower bar shifts toward the right. All colors in between these original colors also shift in the same direction.

If you select a shift toward blue (a cool color), the red colors shift towards the magenta hue, the blue colors toward the cyan hue, and the green colors toward the yellow hue. The lower bar shifts toward the left. Again, all colors in between these original document colors also shift in the same direction.



Figure 23: Color Shift screen

Saturation

This option allows you to adjust the overall richness of color on the output copy. Colors with high saturation are sometimes called vivid colors, while those with low saturation are sometimes called pastel colors.

Use the flower illustrations on the Saturation screen (Figure 24) to anticipate the results of the shift. The left flower illustrates the most pastel setting of saturation. The right flower illustrates the richest or most vivid saturation. The center flower represents the factory default Normal saturation. Selections do not cause any changes to the flower illustrations.



Figure 24: Saturation screen

Variable Color Balance (Yellow, Magenta, Cyan, Black)

These options allow you to adjust the default levels of all four process colors (Yellow, Magenta, Cyan, and Black) for areas of high, medium, and low density on the copies.

Three higher settings, three lower settings, and the normal (medium) settings are available for each density level of each color, as illustrated in Figure 25.

You can adjust each density level and each color independently in any combination.

KEY POINT: Remember that adjusting the amount of any of the process colors affects the complementary colors that use that color.



Figure 25: Sample Color Balance screen

Sharpness

The Sharpness option allows you to adjust the amount of image edge definition on the copies.



NOTE: For optimum sharpness, select the correct Original Type in the Image Quality tab.

Use the Sharp levels (Figure 26) to increase the amount of edge definition for original documents such as maps, line art, or graphics that have crisp lines.

Use the Soft levels (Figure 26) to decrease the amount of edge definition to copy photographs or any other documents for which softer, less focused, output copies are desired. This option is especially useful when copying very coarse dot screens.



Figure 26: Sharpness screen

Margin Shifts for Side 1 and Side 2

This option controls the default Margin Shift. You can set separate defaults for Side 1 and Side 2 images on the output copy.

You can set the following options:

- **No Shift**
- **Auto Center**
- **Corner Shift**

If you select this option, you should also select the Corner Shift option for the appropriate side.

- **Variable Shift**

If you select this option, you should also select the Variable Shift option for the appropriate side.

Corner Shift

Use this option if you selected the Corner Shift option for Margin Shifts for either Side 1 or Side 2.

Touch the desired corner shift position (Figure 27) and then touch **Save** to return to the Feature Defaults screen.



Figure 27: Sample Corner Shift Default screen

Variable Shift

Use this option, illustrated in Figure 28, if you selected the Variable Shift option for Margin Shifts for either Side 1 or Side 2.

To set a horizontal shift, touch the **right arrow** to shift the image to the right edge, or touch the **left arrow** to shift the image to the left edge from 0 to 432 mm.

To set a vertical shift, touch the **up arrow** to shift the image to the top edge, or touch the **bottom arrow** to shift the image to the lower edge from 0 to 432 mm.

Touch **Save** to return to the Feature Defaults screen.



Figure 28: Sample Variable Shift Default screen



Edge Erase

This option allows you to set the Edge Erase default to eliminate the shadows that are caused by the document edges during the copying process.

This feature offers two options, as illustrated in Figure 29:

- No Erase — Uses 2 mm default
- Variable Erase to display an additional screen with variable shift settings.

Under the **Top & Bottom** icon, touch the **up arrow** to increase the amount of erasure at the top and bottom edges. Touch the **down arrow** to decrease the amount of erasure at the top and bottom edges.

Under the **Left & Right** icon, touch the **up arrow** to increase the amount of erasure at the left and right edges. Touch the **down arrow** to decrease the amount of erasure at the left and right edges.

When you are making 2-sided copies, Edge Erase is applied to both sides of the output.



Figure 29: Edge Erase screen with Input Erase Value selected

Original Orientation

This option allows you to indicate the position of most original documents on the Document Glass, as illustrated in Figure 30. An original document may be placed with its image upright or with the top of its image positioned towards the side.

The diagrams on this screen illustrate the correct positioning of documents on the Document Glass.



Figure 30: Original Orientation Default screen

2 Sided Copy

This option allows you to set default copying for 1 to 1 Sided, 1 to 2 Sided, 2 to 2 Sided, or 2 to 1 Sided, as illustrated in Figure 31.



Figure 31: 2 Sided Copying Default screen

Side 2 Rotate

This option should be used if you set the default copying for 2-Sided output. With this option, you can specify whether the 2-sided copy should be made with Flip on Long Edge (head-to-head, book style) or Flip on Short Edge (head-to-toe, calendar style), as illustrated in Figure 32.

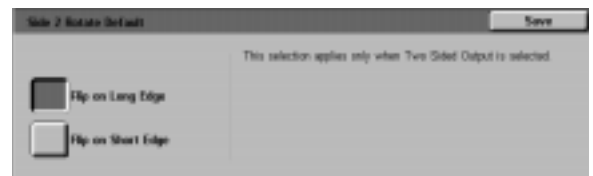

Figure 32: Side 2 Rotate Default screen

3

Multiple-Up

The Multiple-Up feature (Figure 33) enables you to specify whether 1, 2, 4, or 8 images from multiple originals are copied onto a single page. Each image is centered in its space.

If you select 2 Pages Up, use the 2 Pages Up Copy Layout feature described below.

If you select 4 Pages Up or 8 Pages Up, use the 4 & 8 Pages Up Copy Layout feature described below.



Figure 33: Multiple-Up Defaults screen

2 Pages Up

This option (Figure 34) allows you to specify how two images will be placed on a single sheet of paper:

- Left-to-right / top-to-bottom
- Right-to-left / top-to-bottom



Figure 34: 2 Pages Up Default screen

4 & 8 Pages Up

This option allows you to specify how four or eight images will be placed on a single sheet of paper, as illustrated in Figure 35:

- Horizontally, beginning from upper left corner
- Horizontally, beginning from upper right corner
- Vertically, beginning from upper left corner
- Vertically, beginning from upper right corner



Figure 35: 4 Pages Up Default screen

Machine Set-up

Use these settings to limit the number of copy sets and to disable/enable Auto Power Off Prohibition.



KEY POINT: If Auto Power Off Prohibition is enabled, use the Timeouts feature to set the number of minutes required before the copier/ printer powers off.

1 2 3...

- 1 On the Tools screen, touch the **Machine Set-up** icon to display the Machine Set-up screen, as illustrated in Figure 36.
- 2 Review the current settings for each item. To change a setting, use the up and down arrows to highlight the desired item and touch the **Change Settings** button to display the detail screen.

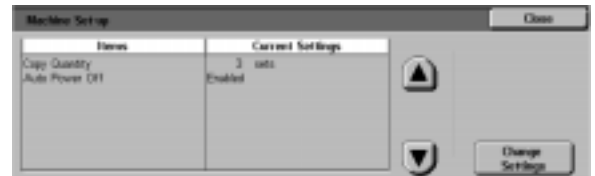

Figure 36: Machine Setup screen

3 Perform one of the following:

- On the Copy Quantity Limit screen (Figure 37), use the numeric keypad to enter the maximum number (1—999) of copies/sets allowed.



Figure 37: Copy Quantity Limit screen

- On the Auto Power Off screen (Figure 38), touch either the Enabled or Disabled button.



Figure 38: Auto Power Off screen

3

4 Touch **Save** to display the Machine Set-up screen.

5 If necessary, repeat steps 2 through 4 for a different item.

6 Touch **Close** to display the Tools screen.

Audio Tones

You can change the Audio Tones settings for the following options:

- Selection Tone
- Conflict Tone
- Control Panel Input Tone
- Machine Ready Tone
- End of Job Tone
- Fault Tone

You can turn the Control Panel Input Tone on or off. For all other options, you can turn the tone off or set its volume to soft, normal or loud.

1 2 3...

- 1 On the Tools screen, touch the **Audio Tones** icon to display the Audio Tones screen, as illustrated in Figure 39.

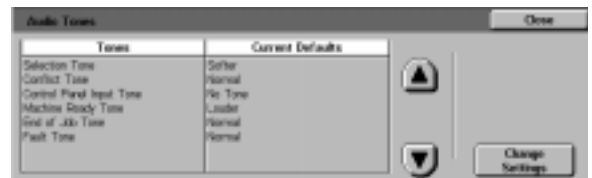

Figure 39: Audio Tones screen

- 2 Review the current settings for each tone. To change a setting, use the up and down arrows to highlight the desired tone and touch the **Change Settings** button to display the detail screen.

3 Perform one of the following:

- For the Control Panel Input Tone (Figure 40), touch **No Tone** or **Tone**.



Figure 40: Control Panel Input Tone screen

- For other tones (Figure 41), touch **No Tone**, **Softer**, **Normal**, or **Louder**.



Figure 41: Sample audio tone setting screen

3

4 Touch **Save** to display the Audio Tones screen.

5 If necessary, repeat steps 2 through 4 for other tones.

6 Touch **Close** to display the Tools screen.

Customize Screens

The Customize Screens feature enables you to set two paper trays and two reduction/enlargement values to display on the Basic Copying tab.

1 2 3...

- 1 On the Tools screen, touch the **Customize Screens** icon to display the Customize Screens screen, as illustrated in Figure 42.



Figure 42: Customize Screens screen

- 2 Touch the **Basic Copying Presets** button to display the Basic Copying Presets screen, as illustrated in Figure 43.



Figure 43: Basic Copying Presets screen

- 3 Review the current settings. Use the up and down arrows to highlight the desired item and touch the **Change Settings** button to display the detail screen for the item.

4 Perform one of the following:

- If you selected a Preset Paper Selection option, touch the desired tray icon on the Preset Paper Selection screen (Figure 44).
The copier/printer illustration highlights your selection.



Figure 44: Preset Tray screen

- If you selected a Reduce/Enlarge Preset option, touch the desired reduction/enlargement percentage button on the Preset Reduce/Enlarge Selection screen (Figure 45).



Figure 45: Preset Reduce/Enlarge Selection screen

3

5 Touch **Save** to display the Basic Copying Presets screen.

6 If necessary, repeat steps 3 through 5 for another item.

7 Touch **Close** to display the Customize Screens screen.

8 Touch **Close** to display the Tools screen.

System Image Quality

This feature enables you to control a number of system image quality options.

With the Image Recognition screen, you can adjust the following options:

- **Text & Photo Recognition** for text and photo separation levels
- **Auto Color Recognition** for black/white and color separation levels
- **Text & Photo Balance** to lower or raise levels of density, optimizing text or photo settings
- **Screening Adjustment** to apply settings to both copy and print modes, copy mode only, or to disable this option

With the Auto Screening Adjust screen, you can select the following options:

- **Halftone Screen** to indicate the level of detail/resolution to use, ranging from halftones (200 line screen) to photographs (200 dpi) to prints (150 dpi).
- **Print Test Original** to produce a Print Test Original and enter the adjustment mode.
- **Adjustment Completed** to print a final test after the adjustment process is completed.

Adjusting Image Recognition settings

1 2 3...

- 1 On the Tools screen, touch the **System Image Quality** icon to display the System Image Quality screen, as illustrated in Figure 46.



Figure 46: System Image Quality screen

3

- 2 Touch the **Image Recognition** icon to display the Image Recognition screen, as illustrated in Figure 47.
- 3 Review the current settings for each item. To change a setting, use the up and down arrows to highlight the desired item and touch the **Change Settings** button to display the image quality detail screen.

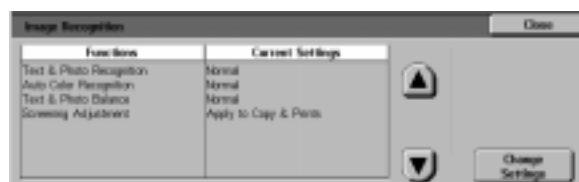

Figure 47: Image Recognition screen

4 Perform one of the following:

- Touch the box that indicates the appropriate image quality level setting for Text & Photo, as illustrated in Figure 48.

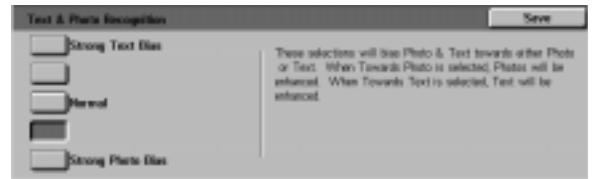

Figure 48: Text & Photo settings

- Touch the box that indicates the appropriate image quality level setting for Auto Color Recognition, as illustrated in Figure 49.

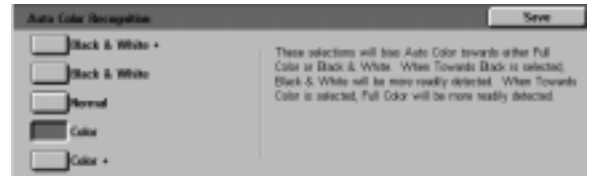

Figure 49: Color Recognition settings

- Touch the box that indicates the appropriate image quality level setting for Text & Photo Balance, as illustrated in Figure 50.



Figure 50: Text & Photo settings

- For Screening Adjustment, touch the box that indicates the appropriate application for the adjustment, as illustrated in Figure 51.



Figure 51: Screening Adjustment screen

- 5** Touch **Save** to display the Image Recognition screen.
- 6** If necessary, repeat steps 2 through 5 for other image recognition items.
- 7** Touch **Close** to display the System Image Quality screen.
- 8** Touch **Close** to display the Tools screen.

3

Auto Screening Adjust

1 2 3...

- 1 On the Tools screen, touch the **System Image Quality** icon to display the System Image Quality screen.
- 2 Touch the **Auto Screening Adjust** icon to display the Auto Screening Adjust screen, as illustrated in Figure 52.

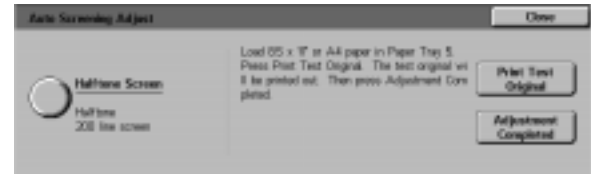

Figure 52: Auto Screening Adjust screen

3

3 Perform one of the following:

- Touch the **Halftone Screen** icon to access the Halftone Screen, as illustrated in Figure 53.

Touch the appropriate setting and touch **Save** to return to the Auto Screening Adjust screen.

- Touch **Print Test Original** to print a sample of the settings. Follow the directions on the Touch Screen to print the test original and enable the adjustment.



NOTE: Test originals are printed from Paper Tray 5.

When the adjustment process is complete, touch **Adjustment Completed** to print another test pattern and confirm the settings.

4 Touch **Close** to display the System Image Quality screen.

5 Touch **Close** to display the Tools screen.



Figure 53: Halftone screen

Machine Timeouts

The Machine Timeouts feature allows you to change the length of time the copier/printer waits before returning to the default settings after a job is complete or only partially programmed, entering Power Saver mode, powering off, or exiting System Administration mode. You may also disable or enable a timeout option through the Timeouts feature screens.

1 2 3...

3

- 1 On the Tools screen, touch the **Machine Timeouts** icon to display the Timeouts screen, as illustrated in Figure 54.
- 2 Review the current settings for each tone. To change a setting, use the up and down arrows to highlight the desired item and touch the **Change Settings** button to display the detail screen.

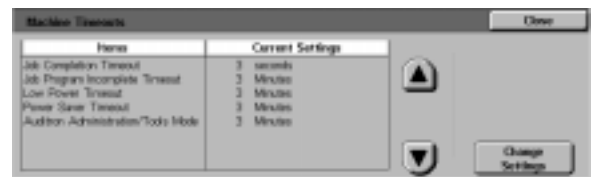

Figure 54: Timeouts screen

3 Perform one of the following:

- Use the **up** and **down** arrows (Figure 55) to increase or decrease the desired time before returning to the default settings after a job is complete or only partially programmed, entering Low Power mode, powering off, or exiting System Administration mode. Be sure to stay within the stated minimum and maximum times.
- Touch the **Timeout Disabled** button to prevent the machine from timing out.



NOTE: The disable option is not available on the Low Power Timeout or Auto Power Off screen. If the copier/printer is not used for over four hours (default setting), it must enter Low Power mode.

To re-enable an option that was previously disabled, use the up arrow to set a new time.

4 Touch **Close** to display the Timeouts screen.

5 If necessary, repeat steps 2 through 4 for other timeout settings.

6 Touch **Close** to display the Tools screen.

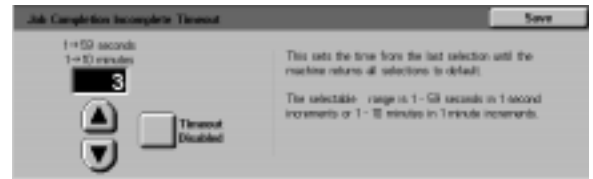

Figure 55: Sample timeout setting screen

Reduce/Enlarge Defaults

Selecting values on the Reduce / Enlarge Presets screen enables you to specify six standard reduction/enlargement percentages to display as defaults on the Reduce/Enlarge screen.

1 2 3...

1 On the Tools screen, touch the **Reduce/Enlarge Defaults** icon to display the Reduce/Enlarge Presets screen, as illustrated in Figure 56.

2 Review the current settings for each item. To change a setting, use the up and down arrows to highlight the desired item and touch the **Change Settings** button to display the preset reduction/enlargement detail screen.

3

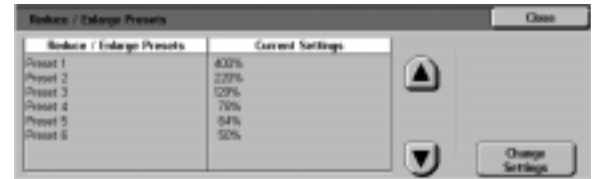

Figure 56: Reduce/Enlarge Presets screen

3 Touch the icon with the desired reduction/enlargement percentage, as illustrated in Figure 57.

4 Touch **Save** to display the Reduce/Enlarge Presets screen.

5 If necessary, repeat steps 2 through 4 for other reduction/enlargement items.

6 Touch **Close** to display the Tools screen.



Figure 57: Sample Preset screen



Change Tools Access Number

Access numbers (sometimes called passwords) are used to ensure that unauthorized individuals do not have access to System Administration Tools. For maximum security, set your Access Number to a number other than the default (11111), and change it periodically (for example, quarterly).



KEY POINT: In choosing a new access number, avoid known values such as birthdates or phone numbers, simple combinations, or five repeated numbers.

3

1 2 3...

- 1 On the Tools screen, touch the **Change Tools Access Number** icon to display the Change Tools Access Number screen, as illustrated in Figure 58.
- 2 Enter a value from the numeric keypad in the New Number box. Touch the **Enter** button.
- 3 Enter the same number in the Confirm New Number box. Touch the **Enter** button.



NOTE: If you make a mistake in entering a value, touch the **Clear** button, retype the number and touch the **Enter** button again.

- 4 Touch **Close** to display the Tools screen.



Figure 58: Change Tools Access Number screen

Original Size Presets

Selecting values on the Original Size Presets screen enables you to specify eleven sizes to display to users as preset defaults on the Original Size screen.

1 2 3...

- 1 On the Tools screen, touch the **Original Size Presets** icon to display the Original Size Presets screen, as illustrated in Figure 59.
- 2 Review the current settings for each preset item.



NOTE: There are two Original Size Presets screens. Check both to set or change all options.

To display additional original size items, touch the **Next Page** or **Previous Page** button.

To change a setting, use the up and down arrows to highlight the desired item and touch the **Change Settings** button to display the original size detail screen.

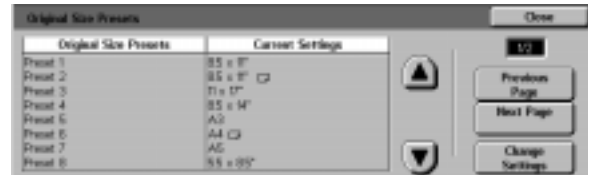

Figure 59: Original Size Presets screen (page 1)

3

- 3** Perform one of the following:
- Touch the **International Sizes** button and touch one of the displayed international sizes
 - Touch the **Inch Sizes** button and touch one of the standard US sizes (Figure 60)
 - Touch the **Variable Size** button. Use the **right** and **left** arrows to set the X dimensions and the **up** and **down** arrows to set the Y dimensions for a customized preset original document size.



Figure 60: Setting Original Size screen with Inch Sizes option selected

- 4** Touch **Save** to display the Original Size Presets screen.
- 5** If necessary, repeat steps 2 through 4 for other original size items.
- 6** Touch **Close** to display the Tools screen.

4. Maintenance

Overview

Some areas of the copier/printer require periodic cleaning or supply replacement to keep it operating reliably.

This chapter specifies the areas of the copier/printer that require customer maintenance and provides procedures for maintaining those areas.

Problems that cannot be solved by the operator need to be referred to the Xerox service representative. Use the procedure, "Calling For Service," in this chapter when it becomes necessary to request a service call.

The procedures for ordering the supplies for the copier/printer and a list of the supplies are also included at the end of the chapter.

Cleaning the Touch Screen

Clean the Touch Screen before the warm up cycle at the start of each day. Remove all dust and fingerprints.

1 2 3...

Wipe the Touch Screen with a clean, lint-free cloth.



CAUTION: To avoid damage to the Touch Screen system, do not use any Xerox or Xerox Europe cleaner, water, or any commercial cleaner on the Touch Screen or on the hard button Control Panel, as illustrated in Figure 1.



Figure 1: Cleaning the Touch Screen

Cleaning the Document Glass

Keep the Document Glass clean to ensure clean copies and acceptable copy quality.

Clean the Document Glass at the beginning of the day and during the day, as needed.

1 2 3...

- 1 Slightly dampen a clean lint-free cloth (Figure 2) with a small amount of Xerox or Xerox Europe Lens and Mirror Cleaner or a glass cleaner that is not abrasive, such as Windex or Glass Plus.



CAUTION: To avoid damage to the copier/printer, do not pour or spray the cleaner directly onto the Document Glass.

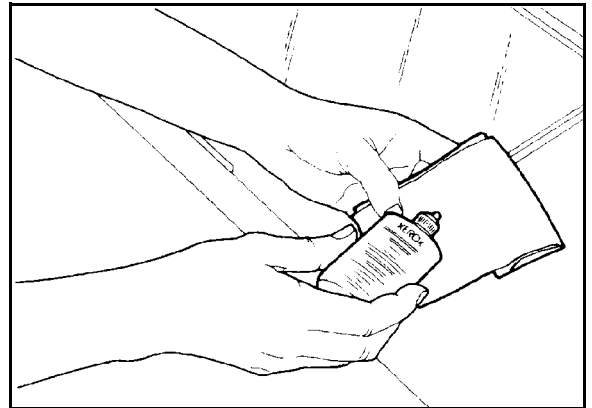

Figure 2: Dampening a lint-free cloth

- 2 Clean the Document Glass by wiping the glass in the lengthwise direction, as illustrated in Figure 3. Keep your fingers off the glass.
- 3 Use a clean, dry, lint-free cloth to wipe off any excess moisture.
- 4 Repeat these steps, as required, until the Document Glass has no visible marks or streaks.

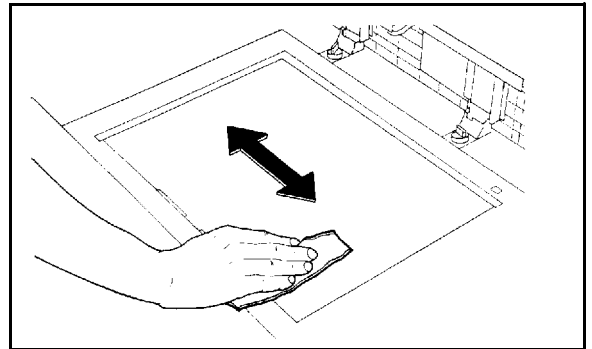

Figure 3: Cleaning the Document Glass

4

Cleaning the Document Glass Cover

1 2 3...

- 1 Lift the Document Glass Cover.
- 2 Slightly dampen a clean, lint-free cloth with a small amount of Film Remover.
- 3 Wipe the underside of the Document Glass Cover until it is clean and dry, as illustrated in Figure 4.

If Film Remover gets on the Document Glass, perform the procedure for cleaning the Document Glass.

- 4 Close the Document Glass Cover.

KEY POINT: Periodically inspect the Document Glass Cover for foreign materials to keep the surface clean at all times. Any white, foreign substance on the surface of the cushion may cause the copier/printer to incorrectly calculate the actual document size or its position, which might result in an unsatisfactory copy.

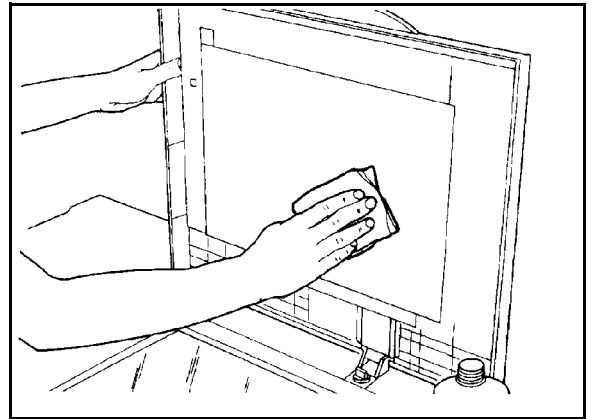

Figure 4: Cleaning the Document Glass Cover

Cleaning the Edit Pad

If your copier/printer is equipped with an Edit Pad, clean the Edit Pad as necessary.

1 2 3...

- 1 Slightly dampen a clean, dry, lint-free cloth with a small amount of Xerox or Xerox Europe Lens and Mirror Cleaner.
- 2 Lift the Clear Plastic Overlay and wipe the top surface of the Edit Pad until it is clean and dry, as illustrated in Figure 5.



CAUTION: Do not crease or fold the Clear Plastic Overlay; permanent damage to the material may result.

- 3 Lower the Clear Plastic Overlay.
- 4 Wipe the top surface of the Clear Plastic Overlay until it is clean and dry, as illustrated in Figure 6.

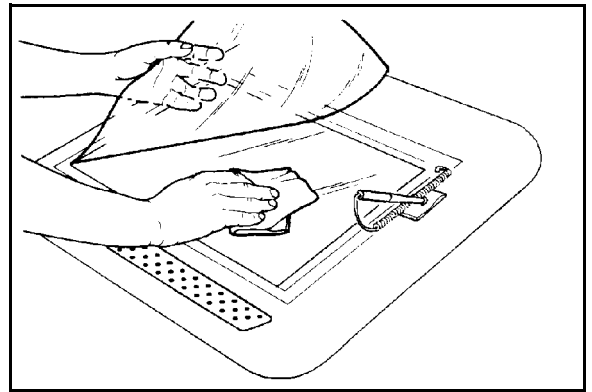

Figure 5: Cleaning the Edit Pad

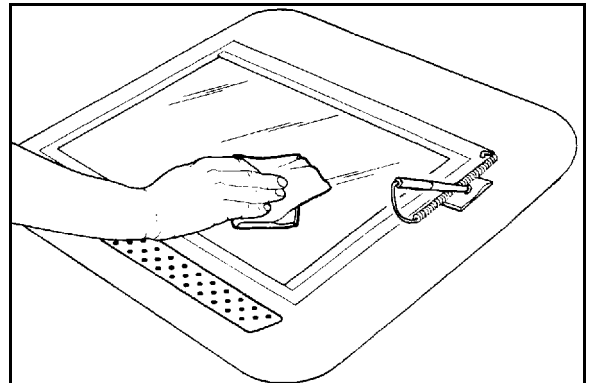

Figure 6: Cleaning the Top Surface of the Clear Plastic Overlay

Supply replacement

Replacing the Dry Ink Cartridge

When a message is displayed to replace a Dry Ink Cartridge (Figure 7), follow the instructions provided here in addition to those on the labels surrounding the cartridges and affixed to the copier/printer.



CAUTION: To prevent dry ink spillage, remove the Dry Ink Cartridge only when the "Cartridge is Empty" message appears on the Touch Screen.

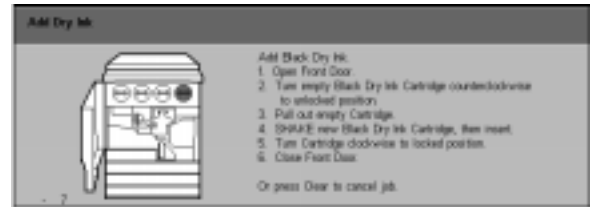

Figure 7: Add Dry Ink message

1 2 3...

1 Open the Front Door of the copier/printer and locate the Dry Ink Cartridges, as illustrated in Figure 8. From left to right the Dry Ink Cartridge colors are Cyan, Magenta, Yellow, and Black.

2 Place a few sheets of paper on the floor under the Dry Ink Cartridge to catch any dry ink that may spill.

4

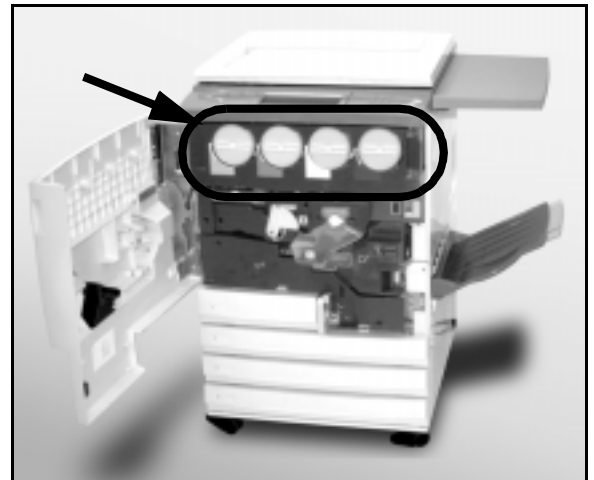

Figure 8: Locating the Dry Ink Cartridge

- 3 Remove the empty cartridge by rotating it counterclockwise until the large dot on the cartridge is aligned with the small dot on the copier/printer, as illustrated in Figure 9.

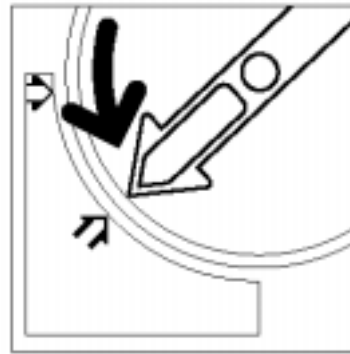

Figure 9: Rotating the Dry Ink Cartridge

- 4 Pull the cartridge completely out of the copier/printer, as illustrated in Figure 10. Dispose of the cartridge according to local regulations.

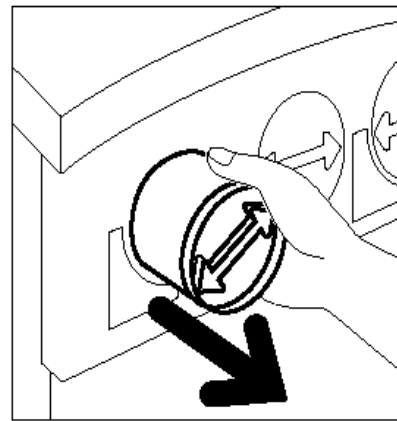

Figure 10: Pulling the Cartridge out of the copier/printer

- 5 Remove the new cartridge from the box.

- 6 Shake the cartridge from side to side, as illustrated in Figure 11.

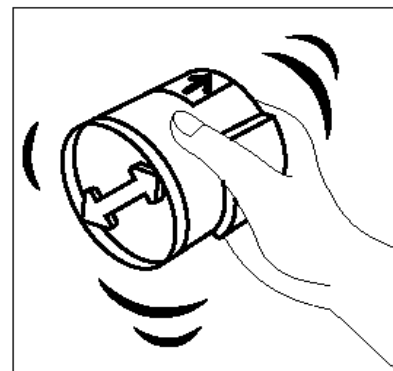

Figure 11: Shaking the Cartridge

- 7 Align the arrow on the cartridge with the raised arrow at the top of the opening, and slide the cartridge into the copier/printer, as illustrated in Figure 12.

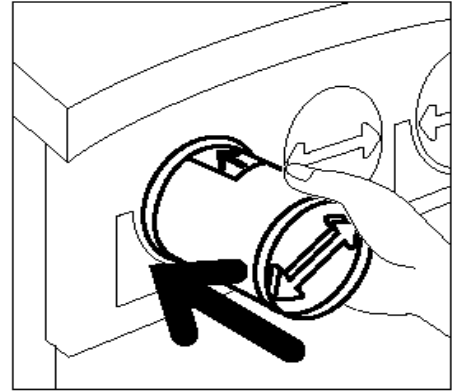

Figure 12: Aligning the Cartridge arrow and sliding the Cartridge into the copier/printer

- 8 Rotate the cartridge clockwise until the dot on the cartridge is aligned with the dot on the copier/printer and the arrows on the cartridge are horizontal, as illustrated in Figure 13

- 9 Close the Front Door of the copier/printer.

- 10 Remove the sheets of paper on the floor under the Dry Ink Cartridge, and dispose of the sheets according to local regulations.

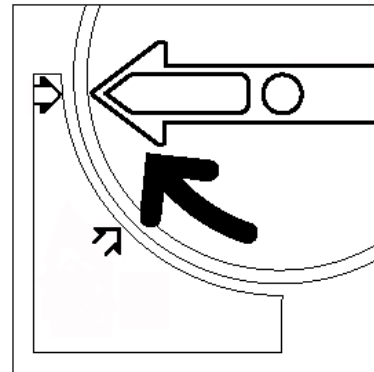

Figure 13: Rotating and securing the Cartridge



CAUTION: Do not use warm or hot water, or cleaning solvents, to remove dry ink from your skin or clothing. This will set the dry ink and make it difficult to remove. If any dry ink gets on your skin or clothing, use a brush to remove the dry ink, blow it off, or wash it off with cold water and mild soap.

CAUTION: If more than one Dry Ink Cartridge needs to be replaced at the same time, be careful to place the new cartridges in their correct color locations.

Replacing the Dry Ink Waste Container

When a message is displayed to replace a Dry Ink Waste Container (Figure 14), follow the instructions provided on this page in addition to those on the labels surrounding the Dry Ink Waste Container and affixed to the copier/printer.



CAUTION: To prevent spilling dry ink, remove the Dry Ink Waste Container only when the "Dry Ink Waste Container is Full" message appears on the Touch Screen.

1 2 3...

- 1 Open the Front Door of the copier/printer.
- 2 Place a few sheets of paper on the floor under the Dry Ink Waste Container to catch any dry ink that may spill.
- 3 Locate the Waste Container (area A in Figure 15) in the upper left of the printer/copier.

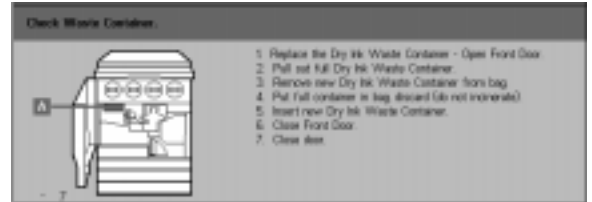

Figure 14: Dry Ink Waste Container message



Figure 15: Locating the old Dry Ink Waste Container

- 4** Grasp the Dry Ink Waste Container with your right hand, as illustrated in Figure 16, and pull the Dry Ink Waste Container completely out of the copier/printer.

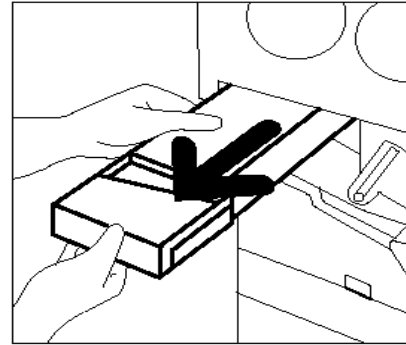

Figure 16: Removing the old Dry Ink Waste Container

- 5** Place the Dry Ink Waste Container in a plastic bag, as illustrated in Figure 17, and dispose of the used container according to local regulations.

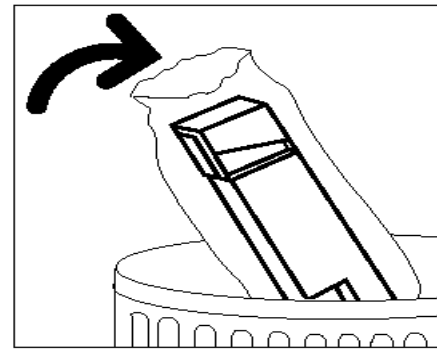

Figure 17: Disposing of the old Dry Ink Waste Container

- 6** Remove the new Dry Ink Waste Container from the box and bag, as illustrated in Figure 18.

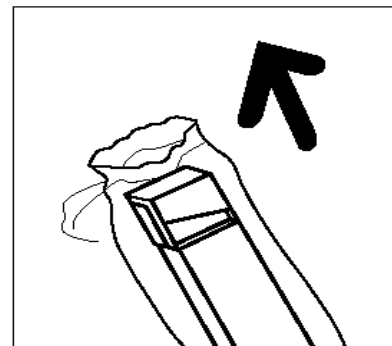

Figure 18: Removing the new Dry Ink Waste Container from the bag

- 7 Align the new Dry Ink Waste Container with the arrow on the copier/printer, and slide the Dry Ink Waste Container into the copier/printer, as illustrated in Figure 19.
- 8 Close the Front Door of the copier/printer.
- 9 Remove the sheets of paper on the floor under the Dry Ink Waste Container, and dispose of the sheets according to local regulations.



CAUTION: Do not use warm or hot water, or cleaning solvents, to remove dry ink from your skin or clothing. This will set the dry ink and make it difficult to remove. If any dry ink gets on your skin or clothing, use a brush to remove the dry ink, blow it off, or wash it off with cold water and mild soap.

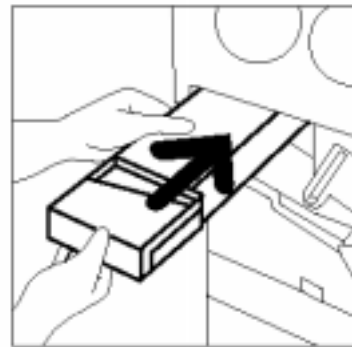

Figure 19: Inserting the new Dry Ink Waste Container

Replacing the Developer Waste Container

When a message is displayed to replace a Developer Waste Container, also known as the Trickle Bottle, follow the instructions provided on this page in addition to those on the labels surrounding the Developer Waste Container and affixed to the copier/printer.



CAUTION: To prevent developer spillage, remove the Developer Waste Container only when the "Developer Waste Container is Full" message appears on the Touch Screen.

1 2 3...

- 1 Open the Front Door of the copier/printer.
- 2 Place a few sheets of paper on the floor under the Developer Waste Container to catch any developer that may spill.
- 3 Locate the Developer Waste container (area C in Figure 20).

4

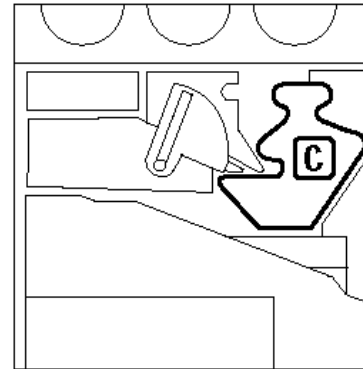

Figure 20: Locating the old Developer Waste Container

- 4** Grasp the Developer Waste Container with your right hand. Pull the Developer Waste Container completely out of the copier/printer, as illustrated in Figure 21.

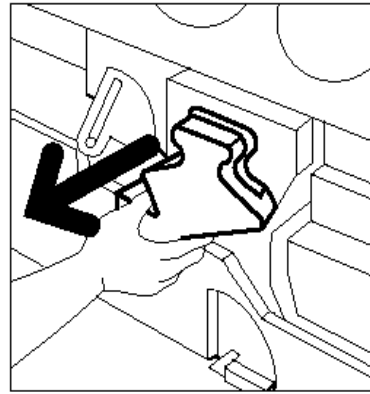

Figure 21: Removing the old Developer Waste Container

- 5** Remove the gold cap from the front of the used Developer Waste Container, as illustrated in Figure 22.

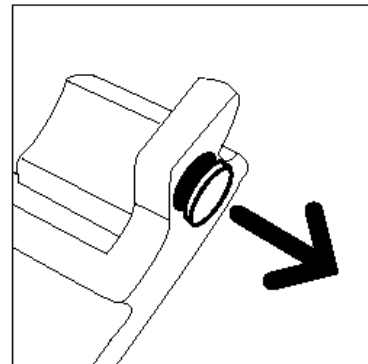

Figure 22: Removing the cap

- 6** Securely push the gold cap over the opening on the back of the waste container, as illustrated in Figure 23, to prevent developer beads from spilling out.

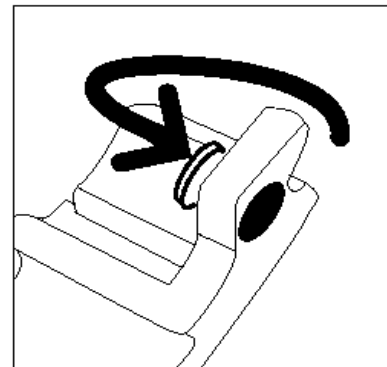

Figure 23: Placing the cap on the waste container

- 7** Place the used Developer Waste Container in a plastic bag, as illustrated in Figure 24, and dispose of it according to local regulations.



Figure 24: Disposing of the new Developer Waste Container

- 8** Remove the new Developer Ink Waste Container from the box and bag, as illustrated in Figure 25.



Figure 25: Removing the new container from the bag

- 9** Align the new Developer Waste Container with the arrow on the copier/printer, then slide the Developer Waste Container into the copier/printer, as illustrated in Figure 26.

- 10** Close the Front Door of the copier/printer.

- 11** Remove the sheets of paper on the floor under the Developer Waste Container and dispose of the sheets according to local regulations.

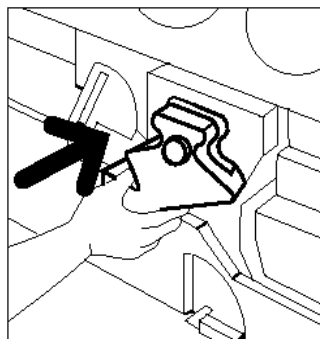

Figure 26: Inserting the new Developer Waste Container

Replacing the Copy/Print Cartridge

When a message is displayed to replace a Copy/Print Cartridge (Figure 27), follow the instructions provided on this page in addition to those on the labels surrounding the Copy/Print Cartridge and affixed to the copier/printer.



CAUTION: To prevent any damage to the new Copy/Print Cartridge, remove the Copy/Print Cartridge only when the “Replace the Copy/Print Cartridge” message appears on the Touch Screen.

CAUTION: Do not pull out the Dry Ink Waste Container when the Copy/Print Cartridge has been pulled out. Damage to the Copy/Print Cartridge may occur.



Figure 27: Replace the Copy/Print Cartridge message

- 1 Open the Front Door of the copier/printer.
- 2 Rotate the Copy/Print Cartridge gold latch release (area B) counterclockwise to its unlocked position, as illustrated in Figure 28 and Figure 29.



NOTE: The “B” pictured on the release in Figure 28 is actually on the cartridge.

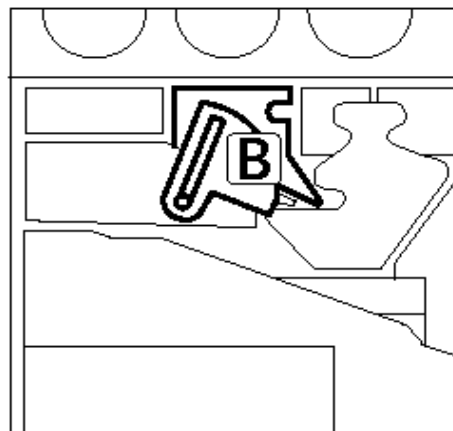

Figure 28: The gold latch release (B)

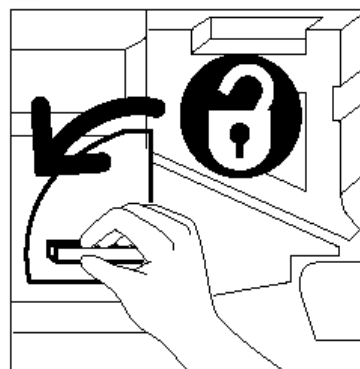

Figure 29: Unlocking the Copy/Print Cartridge

- 3 Grasp the Copy/Print Cartridge gold handle release with your right hand and push up to release the latch, as illustrated in Figure 30. Pull the cartridge out slowly until the strap on top of the Copy/Print Cartridge is visible.
- 4 Grasp the strap with your left hand and remove the cartridge completely out of the copier/printer, as illustrated in Figure 30.

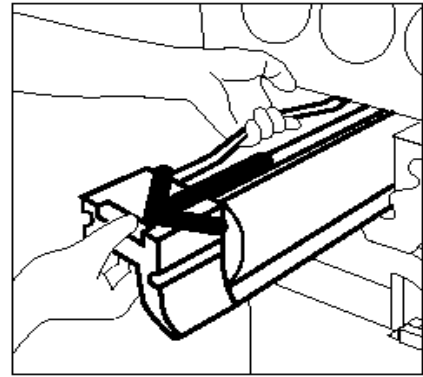

Figure 30: Removing the Copy/Print Cartridge and grasping the Strap

- 5 Remove the new Copy/Print Cartridge from the box.
- 6 Grab the tab on the Protective Instruction Sheet and pull the sheet out slowly counterclockwise from the Copy/Print Cartridge, as illustrated in Figure 31.

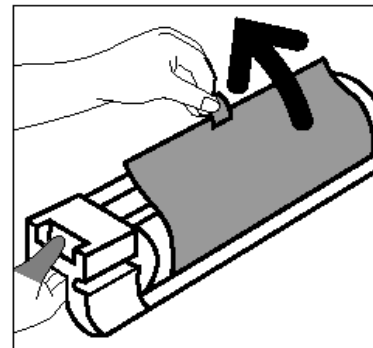

Figure 31: Removing the Protective Instruction Sheet from the Cartridge





CAUTION: To prevent any damage to the new Copy/Print Cartridge, ensure the cartridge alignment is correct before sliding it into the copier/printer.

7 Align the new Copy/Print Cartridge with the arrow on the copier/printer, then slide the new Copy/Print Cartridge into the copier/printer, as illustrated in Figure 32.

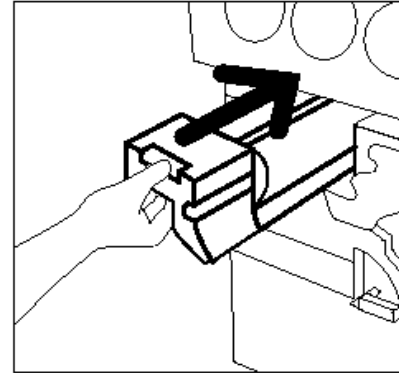

Figure 32: Inserting the new Copy/Print Cartridge

8 Press the new Copy/Print Cartridge in very firmly until the gold handle clicks down.

9 Rotate the Copy/Print Cartridge gold latch release clockwise to its locked position, as illustrated in Figure 33.

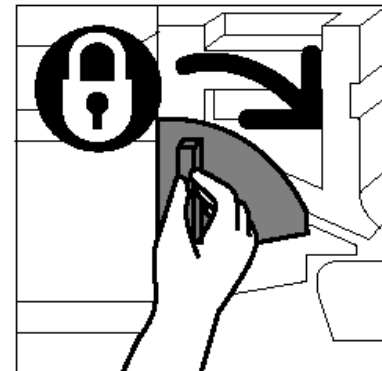

Figure 33: Locking the Copy/Print Cartridge

10 Close the Front Door of the copier/printer.

11 Place the old Copy/Print Cartridge in the box that contained the new cartridge and return it to Xerox according to the instructions on the box.

Replacing the Fuser Oil Cartridge

When a message is displayed to replace the Fuser Oil, follow the instructions provided on this page in addition to those on the labels surrounding the Fuser Oil area (Figure 34) and affixed to the copier/printer.



WARNING: The fuser can be very hot. To avoid personal injury, do not touch any component other than those indicated in the following procedure.



CAUTION: Fuser oil can be slippery. If any fuser oil is spilled on the floor, thoroughly clean the area.



WARNING: Do not place the fuser oil cartridge on the copier/printer. If any fuser oil is spilled on the copier/printer, thoroughly clean it.

WARNING: Fuser oil may cause irritation to your eyes. Thoroughly wash your hands with soap and water after handling the fuser oil cartridge.

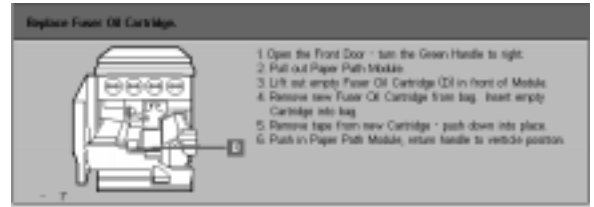

Figure 34: Check the Fuser Oil message

1 2 3...

- 1 Open the Front Door of the copier/printer.
- 2 Place a few sheets of paper on the floor to catch any fuser oil that may spill.
- 3 Rotate the green handle clockwise, to the down position.

4

- 4 Grasp the Paper Path Module and firmly pull the module out of the copier/printer until it is fully open, as illustrated in Figure 35.

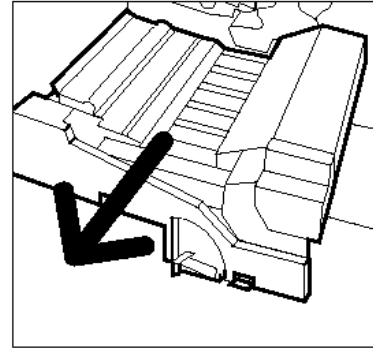

Figure 35: Pulling out the Paper Path Module

- 5 Locate the Fuser Oil Cartridge in the front of the Paper Path Module (area D).
- 6 Lift the Fuser Oil Cartridge straight up off the module, as illustrated in Figure 36. Hold it steady in this position until any excess oil has dripped off the cartridge and into the fuser oil reservoir. Hold a sheet of paper under the bottle nozzle to catch any drips while removing the cartridge from the machine.

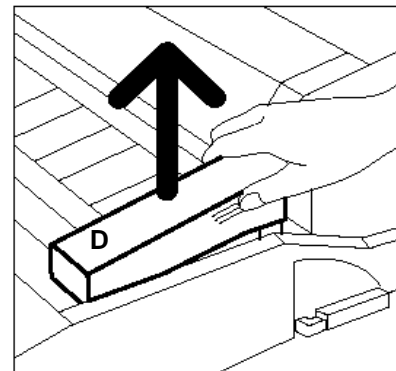

Figure 36: Removing the old Fuser Oil Cartridge (D)

4



WARNING: Do not place the fuser oil cartridge on the copier/printer. If any fuser oil is spilled on the copier/printer, thoroughly clean it.

- 7 Place the old cartridge in a plastic bag, as illustrated in Figure 37, and dispose of it according to local regulations.

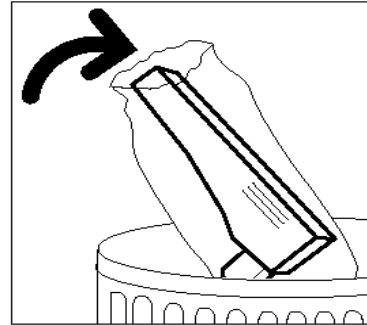

Figure 37: Disposing of the old cartridge

- 8 Remove the new cartridge from the box and bag, as illustrated in Figure 38.

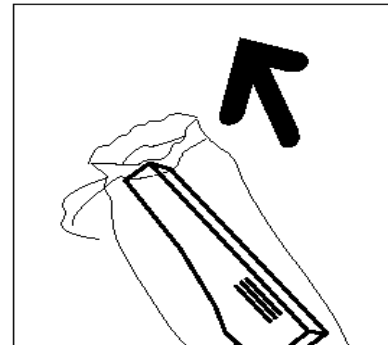

Figure 38: Removing the new cartridge from the box and bag



- 9** Remove the cap at the end of the Fuser Oil Cartridge, as illustrated in Figure 39.

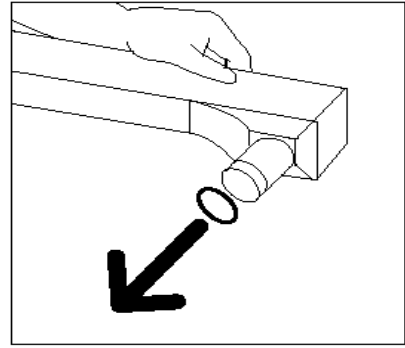

Figure 39: Removing the Fuser Oil Cartridge Cap

- 10** Align the cartridge in the proper position on the Paper Path Module. Press it carefully into place, as illustrated in Figure 40.

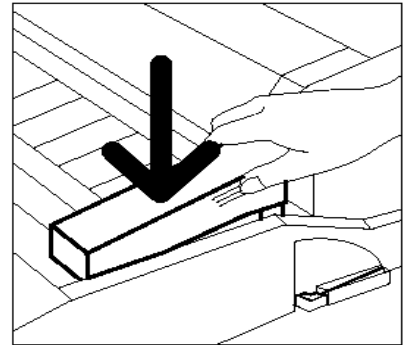

Figure 40: Installing the Fuser Oil Cartridge

- 11** Grasp the Paper Path Module and firmly push the module into the copier/printer.

12 Rotate the Paper Path Module Handle counterclockwise, to the up position, until it is in a locked position.

13 Close the Front Door of the copier/printer.

14 Remove the sheets of paper on the floor under the Paper Path Module and dispose of the sheets according to local regulations.



CAUTION: Fuser oil can be slippery. If any fuser oil has been spilled on the floor, thoroughly clean the area.



WARNING: Do not place the fuser oil cartridge on the copier/printer. If any fuser oil is spilled on the copier/printer, thoroughly clean it.

WARNING: Fuser oil may cause irritation to your eyes. Thoroughly wash your hands with soap and water after handling the fuser oil cartridge.

Replacing the Cleaning Web

When a message is displayed to replace the Cleaning Web (Figure 41), follow the instructions provided on this page in addition to those on the labels near the Cleaning Web affixed to the copier/printer.

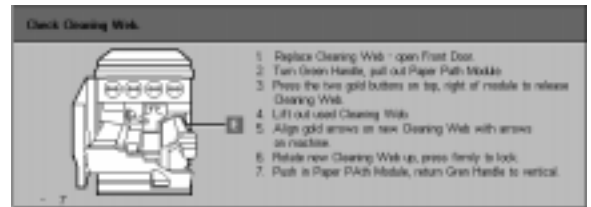

Figure 41: Check the Cleaning Web message



WARNING: The fuser can be very hot. To avoid personal injury, do not touch any components other than those indicated in the following procedure.

1 2 3...

- 1 Open the Front Door of the copier/printer.
- 2 Rotate the Paper Path Module Handle clockwise, to the down position.
- 3 Pull the Paper Path Module out of the copier/printer until it is fully open, as illustrated in Figure 42.

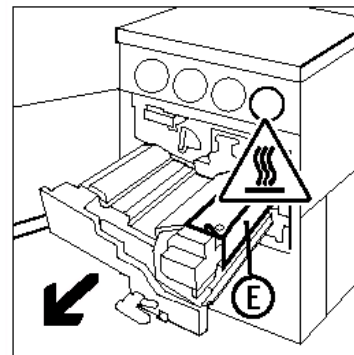

Figure 42: Pulling out the Paper Path Module

4



WARNING: The fuser can be very hot. To avoid personal injury, wait at least 20 minutes before performing the next step to allow the fuser to cool. Do not touch any component other than those indicated in the following procedure.

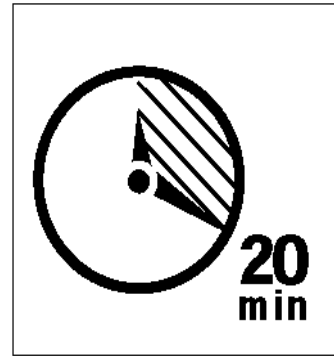

Figure 43: Allow the fuser to cool

- 4 Press down on the Front and Rear Release buttons on the top of the fuser assembly, as illustrated in Figure 44, to unlatch the Cleaning Web (area E). The web opens to the right of the Paper Path Module.

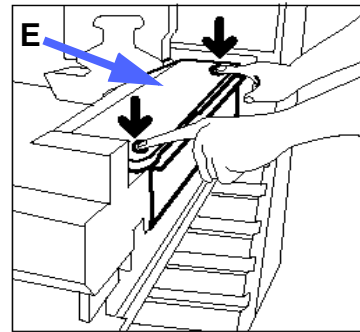

Figure 44: Unlatching the Cleaning Web

- 5 Gently push down on the Cleaning Web (E) and pull it toward the right to remove the web from the copier/printer, as illustrated in Figure 45.
- 6 Place the Cleaning Web in a bag and dispose of the web according to local regulations.



Figure 45: Removing the Cleaning Web



7 Remove the new Cleaning Web from the box.

8 Align the front and rear arrows of the new Cleaning Web with the front and rear arrows on the right side of the fuser, as illustrated in Figure 46.

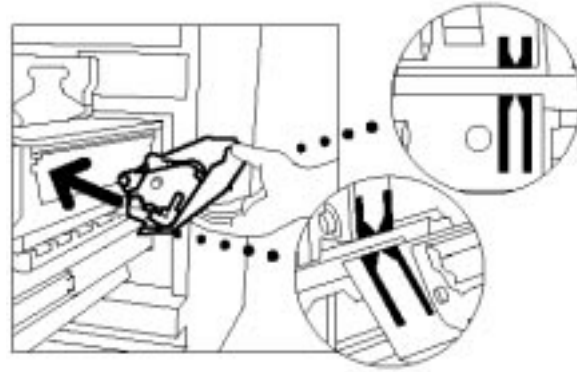

Figure 46: Aligning the new Cleaning Web

9 Rest the Cleaning Web on the black brackets and gently push the top of the new Cleaning Web into place, as illustrated in Figure 47. The Cleaning Web is in position when it stops. Press firmly to ensure that it latches.

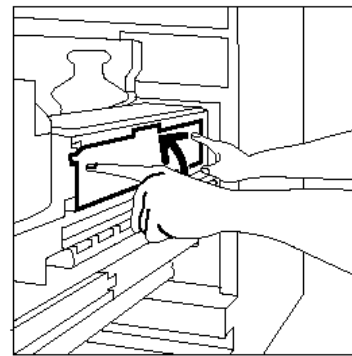

Figure 47: Replacing the new Cleaning Web

4



CAUTION: Do not force the new Cleaning Web into the fuser, or you may damage the Cleaning Web.

10 Grasp the Paper Path Module and push the module into the copier/printer.

11 Rotate the Paper Path Module handle counterclockwise, to the up position, until it is in a locked position.

12 Close the Front Door of the copier/printer.

Calling for Service

There may be times when you will not be able to correct a copier/printer problem. When this happens, you should call for service.

Follow the instructions below before calling for service.

1 2 3...

- 1 Be prepared to provide a complete description of the problem to the service operator. Defining the copier/printer problem accurately may help you and the operator solve the problem over the phone and minimize copier/printer downtime. If the problem cannot be solved by telephone, a service representative will be dispatched to your copier/printer promptly.

- 2 Before you attempt to clear a fault condition, press and hold the **Stop** button to display the fault code on the screen.



NOTE: If an attempt was made to clear the fault before pressing the Stop button, the fault code will not appear.

4

- 3 Record the displayed Fault Codes.
- 4 Record the Machine Serial Number from the label on the inside lower left cover of the copier/printer, as illustrated in Figure 48.
- 5 If copy quality is a problem, take a copy sample to the telephone with you to help you describe the problem or to assist you when answering the questions from the service operator about the defects.
- 6 If possible, use a phone near the copier/printer to call the Service Telephone Number. Follow the instructions provided by the operator.
- 7 For applications support, user help, and service support, call the appropriate number:

US: 1-800-821-2797

Canada: 1-800-939-3769

Europe: _____

Latin America: _____

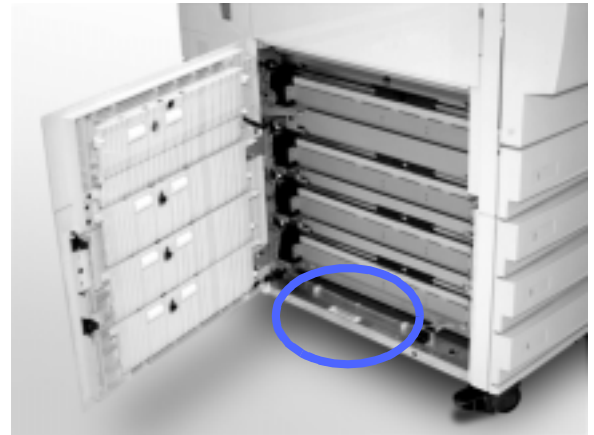

Figure 48: Machine Serial Number location

Ordering supplies

Be sure to check your supplies regularly and order replacements before you run out.

Call the appropriate number listed below for consumable supplies:

US 1-800-822-2200

Canada (English) 1-800-668-0199

Canada (French) 1-800-668-0133

Europe: _____

Latin America: _____

Give the representative the following information:

- Your Xerox Customer Number
(in the format X-XXX-XXX-XXXX)

- Your Model Number:

DocuColor 12

DocuColor 12 with External Digital Front
End (DFE)

- Item description
- Quantities of items required



Supplies to keep on hand

Refer to the following table for a list of the supplies you should keep on hand and the part numbers for each item.

Supply Items	USA	Xerox Canada	Xerox Europe
Lens and Mirror Cleaner	43P81	43P81	8R9017B
Lint Free Cloth	19P3025	19P3025	19P3025
Film Remover	43P45	43P45	8R90176
Developer, Black	5R616	5R616	5R90241
Developer, Cyan	5R617	5R617	5R90242
Developer, Magenta	5R618	5R618	5R90243
Developer, Yellow	5R619	5R619	5R90244
Dry Ink, Black	6R945	6R945	6R90280
Dry Ink, Cyan	6R946	6R946	6R90281
Dry Ink, Magenta	6R947	6R947	6R90282
Dry Ink, Yellow	6R948	6R948	6R90283
Fuser Oil Cartridge	8R7975	8R7975	8R7982
Dry Ink Waste Container	8R7976	8R7976	8R7983
Developer Waste Container	8R7977	8R7977	8R7984
Cleaning Web	8R7980	8R7980	8R7985
Copy/Print Cartridge (FSMA)	13R557	13R557	13R559
Copy/Print Cartridge (T&M)	13R558	13R558	13R560

Recommended papers and transparencies

For general information, refer to the *Color Materials Usage Guide*.

For additional specific information regarding materials that have been tested and approved for use in the DocuColor 12, refer to the *Recommended Materials for the DocuColor 12*. This list is available on the Xerox web site and will be updated periodically. Contact your Xerox representative for additional details.

Replacement Manuals (USA market only)

To order a replacement *DocuColor 12 User Guide*, *Quick Reference Card*, or *System Administration Guide*, call the Xerox Customer Parts & Product Support Center at the following number:

1-800-828-5881 (USA only)

Be prepared to provide your Customer Order Number and the Serial Number of your copier/printer.



Prepared by:
Xerox Corporation
Multinational Customer and Service Education
780 Salt Road
Webster, New York 14580

701P99663