

# SaniForce™ Air Motors

3A1211M  
EN

For use on SaniForce™ piston pumps, which are used to transfer medium to high viscosity fluids in applications requiring high sanitation. For professional use only.

- Model 24G785, Series A, 3.5 in. Air Motor
- Model 24G786, Series A, 6.0 in. Air Motor
- Model 24G787, Series A, 7.5 in. Air Motor
- Model 24R491, Series A, 6.0 in. Air Motor
- Model 24R015, Series A, 7.5 in. Air Motor
- Model 24W754, Series A, 6.0 in. Air Motor



#### Important Safety Instructions

Read all warnings and instructions in this manual. For complete warnings and instructions see your pump or package manual. Hazard symbols refer to specific procedure risks. Save all instructions.

See page 5 for model information, including maximum air inlet pressure.



Air Motor shown with Shrouds and Lift Ring (see page 5)

ti16220a

# Contents











<b>Related Manuals</b> .....	<b>2</b>	Repair Air Motor .....	12
<b>Warnings</b> .....	<b>3</b>	Attach the Shroud .....	13
<b>Models</b> .....	<b>5</b>	<b>Parts</b> .....	<b>14</b>
<b>Component Identification</b> .....	<b>6</b>	Air Motor Parts — All Models .....	15
Grounding .....	6	Shroud Kits, Fittings, and Fasteners* .....	16
<b>Troubleshooting</b> .....	<b>7</b>	Air Motor Seal Kits .....	17
<b>Repair</b> .....	<b>8</b>	Model 24A352 Air Valve Parts .....	17
Preventive Maintenance Schedule .....	8	Air Valve Kits .....	18
Pressure Relief Procedure .....	8	<b>Dimensions</b> .....	<b>19</b>
Remove the Shroud .....	8	<b>Technical Data</b> .....	<b>21</b>
Repair Air Valve .....	9	<b>Graco Standard Warranty</b> .....	<b>22</b>
Replace Pilot Valves .....	11		

# Related Manuals

Manual	Description
3A0733	SaniForce 6:1 Sanitary Pump
3A0734	SaniForce 5:1 Sanitary Pump
3A0735	SaniForce 12:1 Sanitary Pump
3A0591	SaniForce Sanitary Ram Modules
311163	SaniForce Bin Evacuation System

# Warnings

The following warnings are for the setup, use, grounding, maintenance, and repair of this equipment. The exclamation point symbol alerts you to a general warning and the hazard symbol refers to procedure-specific risk. When these symbols appear in the body of this manual, refer back to these warnings. Additional, product-specific warnings may be found throughout the body of this manual where applicable.

 <b>WARNING</b>	
  	<p><b>SKIN INJECTION HAZARD</b></p> <p>High-pressure fluid from dispensing device, hose leaks, or ruptured components will pierce skin. This may look like just a cut, but it is a serious injury that can result in amputation. <b>Get immediate surgical treatment.</b></p> <ul style="list-style-type: none"> <li>• Do not point dispensing device at anyone or at any part of the body.</li> <li>• Do not put your hand over the fluid outlet.</li> <li>• Do not stop or deflect leaks with your hand, body, glove, or rag.</li> <li>• Follow the <b>Pressure Relief Procedure</b> when you stop dispensing and before cleaning, checking, or servicing equipment.</li> <li>• Tighten all fluid connections before operating the equipment.</li> <li>• Check hoses and couplings daily. Replace worn or damaged parts immediately.</li> </ul>
 	<p><b>MOVING PARTS HAZARD</b></p> <p>Moving parts can pinch, cut or amputate fingers and other body parts.</p> <ul style="list-style-type: none"> <li>• Keep clear of moving parts.</li> <li>• Do not operate equipment with protective guards or covers removed.</li> <li>• Pressurized equipment can start without warning. Before checking, moving, or servicing equipment, follow the <b>Pressure Relief Procedure</b> and disconnect all power sources.</li> </ul>
   	<p><b>FIRE AND EXPLOSION HAZARD</b></p> <p>Flammable fumes, such as solvent and paint fumes, in <b>work area</b> can ignite or explode. To help prevent fire and explosion:</p> <ul style="list-style-type: none"> <li>• Use equipment only in well ventilated area.</li> <li>• Eliminate all ignition sources; such as pilot lights, cigarettes, portable electric lamps, and plastic drop cloths (potential static arc).</li> <li>• Keep work area free of debris, including solvent, rags and gasoline.</li> <li>• Do not plug or unplug power cords, or turn power or light switches on or off when flammable fumes are present.</li> <li>• Ground all equipment in the work area. See <b>Grounding</b> instructions.</li> <li>• Use only grounded hoses.</li> <li>• Hold gun firmly to side of grounded pail when triggering into pail.</li> <li>• If there is static sparking or you feel a shock, <b>stop operation immediately</b>. Do not use equipment until you identify and correct the problem.</li> <li>• Keep a working fire extinguisher in the work area.</li> </ul>

# ⚠ WARNING



## EQUIPMENT MISUSE HAZARD

Misuse can cause death or serious injury.

- Do not operate the unit when fatigued or under the influence of drugs or alcohol.
- Do not exceed the maximum working pressure or temperature rating of the lowest rated system component. See **Technical Data** in all equipment manuals.
- Use fluids and solvents that are compatible with equipment wetted parts. See **Technical Data** in all equipment manuals. Read fluid and solvent manufacturer's warnings. For complete information about your material, request MSDS from distributor or retailer.
- Do not leave the work area while equipment is energized or under pressure. Turn off all equipment and follow the **Pressure Relief Procedure** when equipment is not in use.
- Check equipment daily. Repair or replace worn or damaged parts immediately with genuine manufacturer's replacement parts only.
- Do not alter or modify equipment.
- Use equipment only for its intended purpose. Call your distributor for information.
- Route hoses and cables away from traffic areas, sharp edges, moving parts, and hot surfaces.
- Do not kink or over bend hoses or use hoses to pull equipment.
- Keep children and animals away from work area.
- Comply with all applicable safety regulations.



## PERSONAL PROTECTIVE EQUIPMENT

You must wear appropriate protective equipment when operating, servicing, or when in the operating area of the equipment to help protect you from serious injury, including eye injury, hearing loss, inhalation of toxic fumes, and burns. This equipment includes but is not limited to:

- Protective eyewear, and hearing protection.
- Respirators, protective clothing, and gloves as recommended by the fluid and solvent manufacturer.

# Models

Check your motor's identification plate (ID) for the 6-digit part number of your motor.

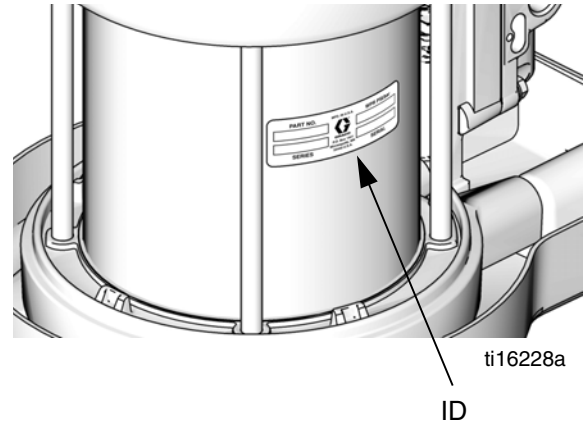

Air Motor Part Number	Air Motor in Kit with Shrouds	Series	Displacement (cc per cycle)	Stroke (in.)	Piston Diameter, in. (mm)	Maximum Air Inlet Pressure psi (MPa, bar)
24G785	24J765	A	800	4.75	3.5 (89)	100 psi (0.7 MPA, 7.0 bar)
24G786	24J764	A	2200	4.75	6.0 (152)	100 psi (0.7 MPA, 7.0 bar)
24G787	24J760	A	3500	4.75	7.5 (191)	100 psi (0.7 MPA, 7.0 bar)
24R491	-----	A	2200	4.75	6.0 (152)	100 psi (0.7 MPA, 7.0 bar)
24R015	-----	A	3500	4.75	7.5 (191)	100 psi (0.7 MPA, 7.0 bar)
24W754	-----	A	2200	4.75	6.0 (152)	100 psi (0.7 MPA, 7.0 bar)

# Component Identification

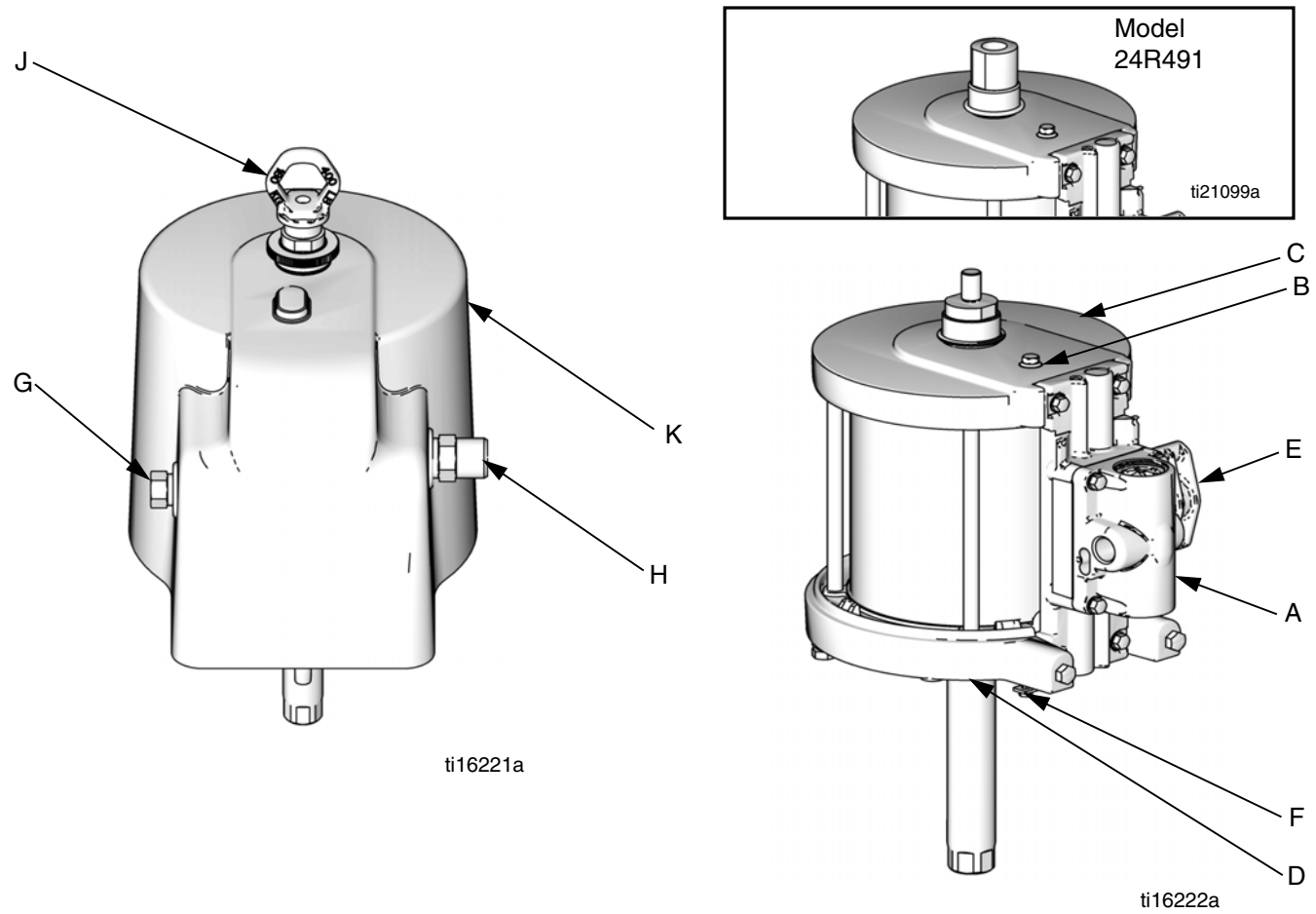

FIG. 1. SaniForce Air Motor components

**Key:**

**Air Motor Kit Components**

- A Air valve
- B Pilot valve (bottom pilot valve is out of view)
- C Top cover
- D Bottom cover
- E Manifold
- F Ground screw

**Lift Ring, Shrouds, and Fittings**





- G Air inlet, 1/2 in. npt(f)
- H Air outlet, 3/4 in. npt
- J Lift Ring
- K Upper Shroud
- L Lower Shroud (out of view)

## Grounding

<p>The equipment must be grounded. Grounding reduces the risk of static and electric shock by providing an escape wire for the electrical current due to static build up or in the event of a short circuit.</p>			

See FIG. 1. Connect a ground wire (Graco PN 238909) to the ground screw (12) on the bottom cover of the air motor, under the shroud. Connect the other end of the ground wire to a true earth ground.

# Troubleshooting

						
<p><b>Relieve the pressure</b> before checking or servicing the equipment.</p>						

**NOTE:** Check all possible problems and causes before disassembling the pump.





Problem	Cause	Solution
Air motor will not run.	Damaged air valve (17).	Replace or service air valve (17). See page 9.
	Damaged pilot valve (19).	Replace pilot valves (19). See page 11.
Air continuously exhausting around air motor piston rod.	Damaged u-cups (3, 33).	Replace piston rod u-cups (3, 33). See page 12.
Air continuously exhausting from muffler.	Damaged air valve plate (105) or cup (112).	Replace or service air valve (17). See page 9.
	Damaged piston o-ring (8).	Replace seals. See page 12.
Air motor “bounces” at top of stroke.	Damaged bottom pilot valve.	Replace bottom pilot valve (19). See page 11.
Air motor “bounces” at bottom of stroke.	Damaged top pilot valve.	Replace top pilot valve (19). See page 11.
Icing inside motor.	Air motor operating at high pressure or high cycle rate.	Reduce pressure, cycle rate, or duty cycle of motor.
		Reduce dew point of compressed air in moisture coalescing filter.

# Repair

## Preventive Maintenance Schedule

The operating conditions of your system determine how often maintenance is required. Establish a preventive maintenance schedule by recording when and what kind of maintenance is needed, and then determine a regular schedule for checking your system.

## Pressure Relief Procedure

				
<ul style="list-style-type: none"> <li>• Trapped air can cause the pump to cycle unexpectedly, which could result in serious injury from skin injection or moving parts.</li> <li>• Relieve pressure when you stop pumping and before cleaning, checking, or servicing equipment.</li> <li>• Do not lift or move motor while pressurized.</li> </ul>				

1. Shut off the air supply to the pump.
2. Close the bleed-type master valve (required in system).
3. Open the fluid ball valve and/or dispensing valve to relieve fluid pressure.

## Remove the Shroud

1. Stop the pump at the middle of its stroke. Follow **Pressure Relief Procedure**, page 8.
2. Disconnect air lines.
3. Remove exhaust fitting (42) and air inlet fitting (43) with o-ring (44).
4. Remove the lift ring (41), hand screw (40), and o-ring (39).
5. Lift the top shroud (46) straight up off the motor.
6. Remove four screws (48). Slide the bottom shroud (47) down.

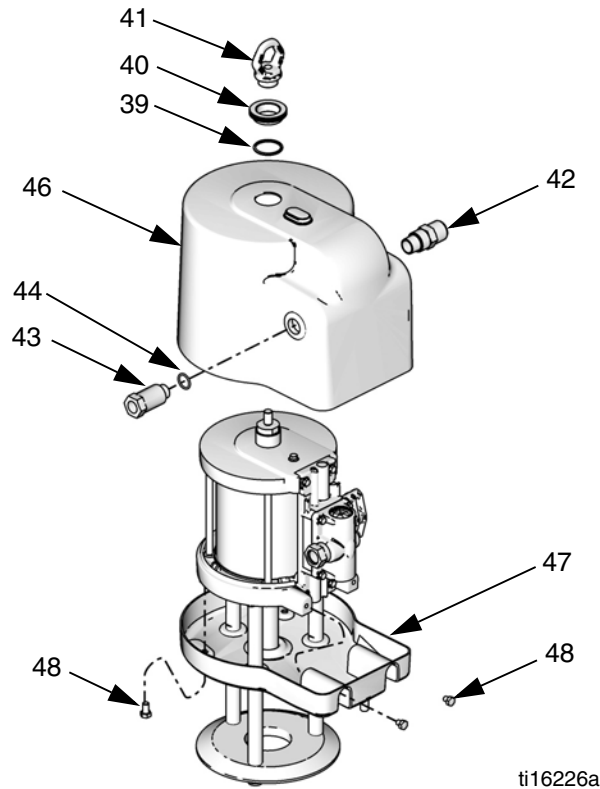

**FIG. 2. Shroud removal**

ti16226a



## Repair Air Valve



### Replace Complete Air Valve

1. Stop the pump at the middle of its stroke. Follow **Pressure Relief Procedure**, page 8.
2. Disconnect air lines.
3. See **Remove the Shroud**, page 8.

**NOTE:** You do not need to remove the bottom shroud to replace or repair the air valve.

4. See **Parts**, page 14. Remove screws (18). Remove the air valve (17) and gasket (16\*◆).
5. To repair the air valve, go to **Disassemble the Air Valve**, step 1. To install a replacement air valve, continue with Step 6.
6. Lubricate and align the new air valve gasket (16\*◆) on the manifold.
7. Lubricate the air valve plate (105◆), then attach the air valve (17). Torque screws to 95-105 in-lb (11-12 N•m).
8. See **Attach the Shroud**, page 13.

### Replace Seals or Rebuild Air Valve

#### NOTE:

- Air Valve Seal Kits are available. See page 18 to order the correct kit for your pump. Parts are marked with an †.
- Air Valve Repair Kits are available. See page 18 to order the correct kit for your pump. Parts are marked with an ◆.
- Air Valve End Cap Kits are available. See page 18 to order the correct kit for your pump. Parts are marked with an ⌘.

### Disassemble the Air Valve

1. Perform steps 1-4 under **Replace Complete Air Valve**, page 9.
2. See FIG. 3. Use a 2 mm or 5/64 hex key to remove two screws (109†◆). Remove the valve plate (105◆), cup (112◆), and spring (111◆).

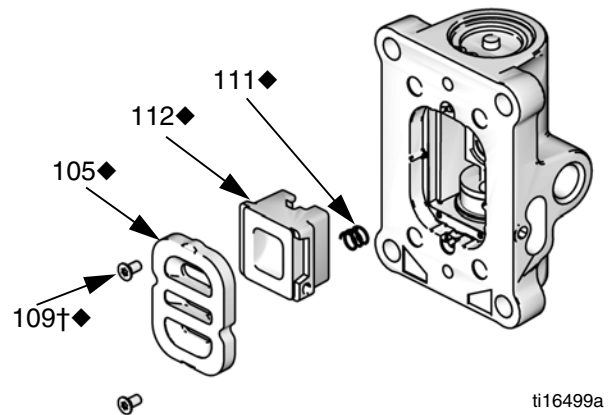

**FIG. 3. Air plate removal**

3. Remove the snap ring (110◆⌘) from each end. Use the piston to push the end caps (107⌘) out of the ends. Remove end cap o-rings (106†⌘◆).
4. Remove the piston (102◆). Remove the u-cup seals (108†◆) from each end and the detent assembly (103◆) and detent cam (104◆) from the center.

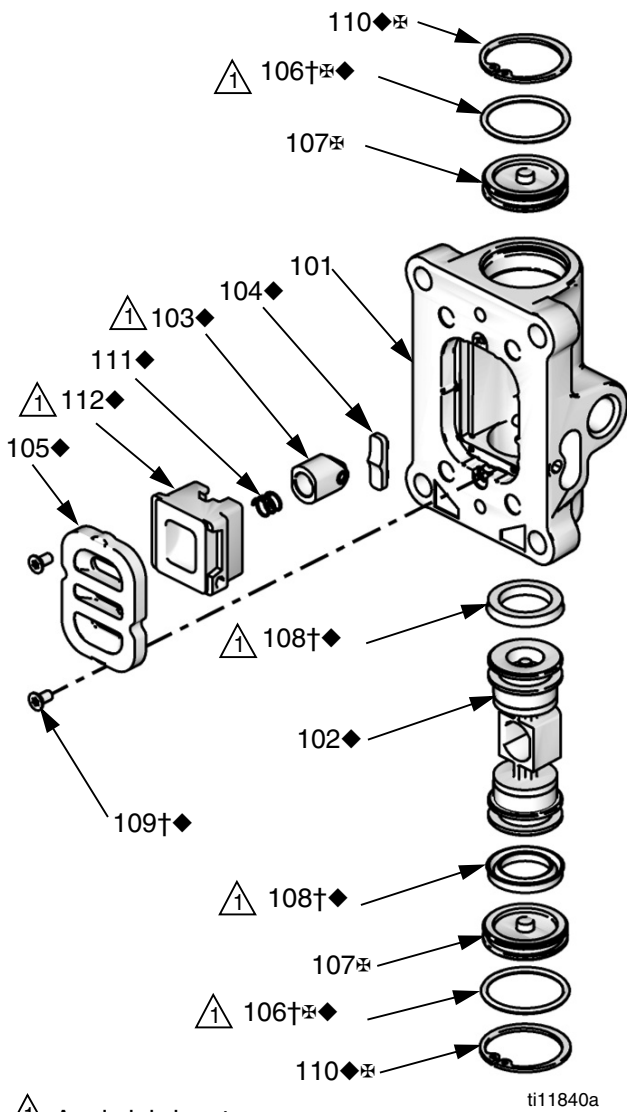

Apply lubricant.

**FIG. 4. Air Valve**

**Reassemble the Air Valve**

1. Lubricate detent cam (104◆) and install into housing.
2. Lubricate the u-cups (108†◆) and install on the piston (102◆) with lips facing toward the center of the piston.

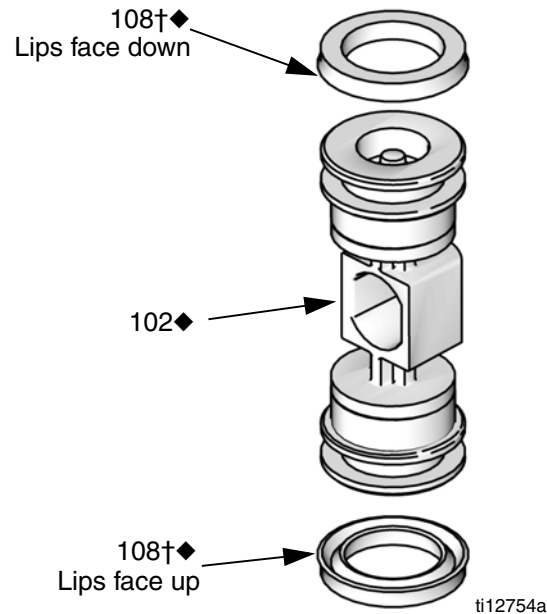

**FIG. 5. Air valve u-cup installation**

3. Lubricate both ends of the piston (102◆) and install it in the housing.
4. Lubricate and install the detent assembly (103◆) into the piston.
5. Lubricate new o-rings (106†◆) and install on the end caps (107⊕). Install the end caps into the housing.
6. Install a snap ring (110◆⊕) on each end to hold end caps in place.

7. Install the spring (111◆). Lubricate and install the air valve cup (112◆). Align the small round magnet with the air inlet.

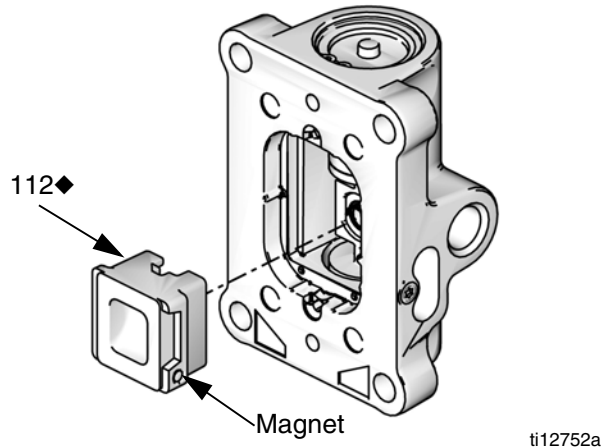

**FIG. 6. Air valve cup installation**

8. Install the valve plate (105◆). Tighten the screws (109†◆) to hold it in place.

## Replace Pilot Valves

1. Stop the pump at the middle of its stroke. Follow **Pressure Relief Procedure**, page 8.
2. Disconnect the air line to the motor.
3. See **Remove the Shroud**, page 8.
4. Use a 10 mm socket wrench to remove the old pilot valves (19) from the top and bottom covers.
5. Lubricate and install the new pilot valves (19). Torque to 95-105 in-lb (11-12 N•m).

## Repair Air Motor



**NOTE:** Air Motor Seal Kits are available. See page 17 for the correct kit for your motor. Parts included in the kit are marked with an asterisk (\*). For best results, use all the parts in the kit.

### Preliminary Steps

1. Stop the pump at the middle of its stroke. Follow **Pressure Relief Procedure**, page 8.
2. Disconnect air lines.
3. See **Remove the Shroud**, page 8.

### Disassemble the Air Motor

1. Remove the tie rod nuts, tie rods, tie rod plate, and bottom shroud.
2. Use a 10 mm socket wrench to remove four screws (18). Remove the air valve (17) and gasket (16\*♦).
3. Remove four screws (18) and remove the manifold (15\*) and gasket (14\*).
4. Use a 10 mm socket wrench to remove the pilot valves (19) from the top and bottom cover.
5. Remove the adapter (31) and o-ring (32) from center of top cover (13).
6. Remove the tie bolts (10).
7. Remove the top cover. Remove the o-ring (9\*).
8. Remove the cylinder (11).
9. Slide the piston assembly (5) straight up off the bottom cover.

#### NOTICE

To prevent damage, do not attempt to take apart the piston assembly (5).

10. Remove o-ring (8\*) from around the piston.
11. Remove retaining ring (4\*), u-cup seals (3\*, 33\*), and o-ring (9\*) from the bottom cover.

### Reassemble the Air Motor

**NOTE:** Use NLGI No 1, bentone-based grease for lubricant. **Exception:** Use appropriate sanitary lubricant for the center grommet in the bottom shroud.

**NOTE:** For easier reassembly, start with the top cover (13) turned over on the workbench and assemble the air motor upside-down.

1. Lubricate and install the o-ring (9\*) on the top cover (13).
2. **24G787 only:** Install the upper bumper (29) on the top cover (13).
3. Lubricate the inside of the cylinder (11). Lower the cylinder (11) onto the top cover (13).
4. Lubricate and install the o-ring (8\*) around the piston (5).
5. Slide the piston assembly (5) down into the cylinder (11). Be sure the o-ring (9\*) stays in place.
6. See FIG. 7. Lubricate and install new u-cup seal with flange (33\*) in the bottom of the bearing in the bottom cover (1). The u-cup must face up and the flange must face down. Lubricate and install new u-cup seal (3\*) in the top of the bearing. Lips must face up. Install retaining ring (4\*).

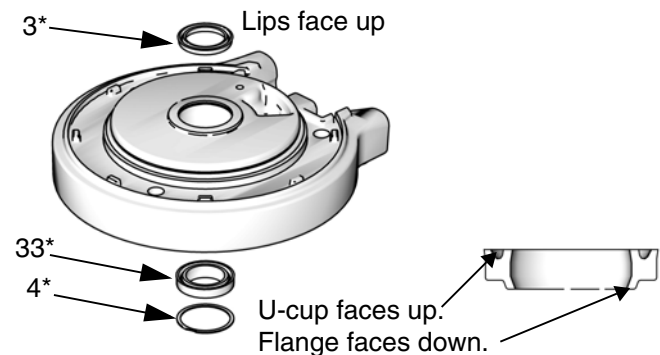

ti12755a

**FIG. 7. Air motor u-cup installation**

7. Lubricate and install the o-ring (9\*) on the bottom cover (1).
8. **24G787, 24G786, and 24W754 only:** Install the piston bumper (28) on the bottom cover (1).

9. Carefully place the bottom cover (1) on the cylinder (11), sliding the rod through the bearing. The manifold surfaces of the top and bottom covers must align.
10. Install the tie bolts (10) hand tight.
11. Install two gaskets (14\*) on the manifold (15). Install the manifold (15). Torque bolts to 95-105 in-lb (10.7-11.9 N•m).
12. Align the air valve gasket (16\*♦) on the manifold, then attach the air valve.
13. Tighten the tie bolts (10) halfway. Work in a criss-cross pattern. Continue tightening the bolts in pattern to the torque specified in the following table.

Air Motor	Torque
24G785	11-13 ft-lb (15-18 N•m)
24G786, 24G787, 24R491, 24R015, and 24W754	25-30 ft-lb (34-40 N•m)

14. Lubricate and install pilot valves (19) in top and bottom cover. Torque to 95-105 in-lb (11-12 N•m).
15. Install the adapter (31) and o-ring (32) in the center of the top cover (13). Lubricate or apply sealant to the o-ring as specified in the following table.

Air Motor	O-Ring
24G785, 24G786, 24G787	PTFE; apply sealant.
24R491, 24R015, 24W754	Buna-N; apply lubricant.

## Attach the Shroud

1. Inspect the grommets on the top and bottom shrouds. Order Kit 16G628 (for 3.5 in. air motors) or Kit 16G385 (for 6.0 in. or 7.5 in. air motors).

**NOTE:** The piston rod grommet (21a) must be installed with the flat side down, as shown. The grommet will be flush with the shroud when properly installed. It will not remain in place if installed upside down. The other two grommets are reversible.

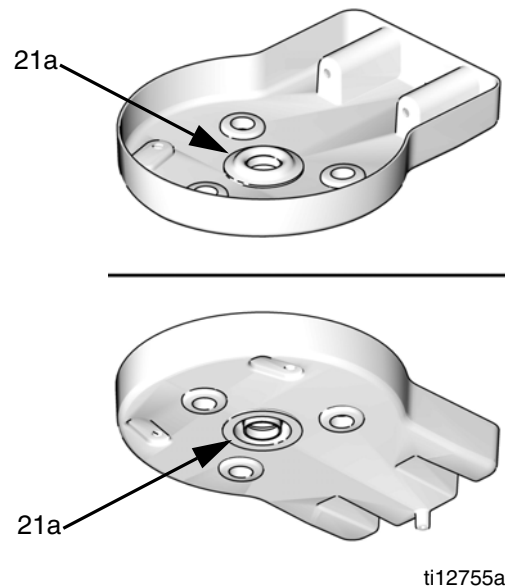
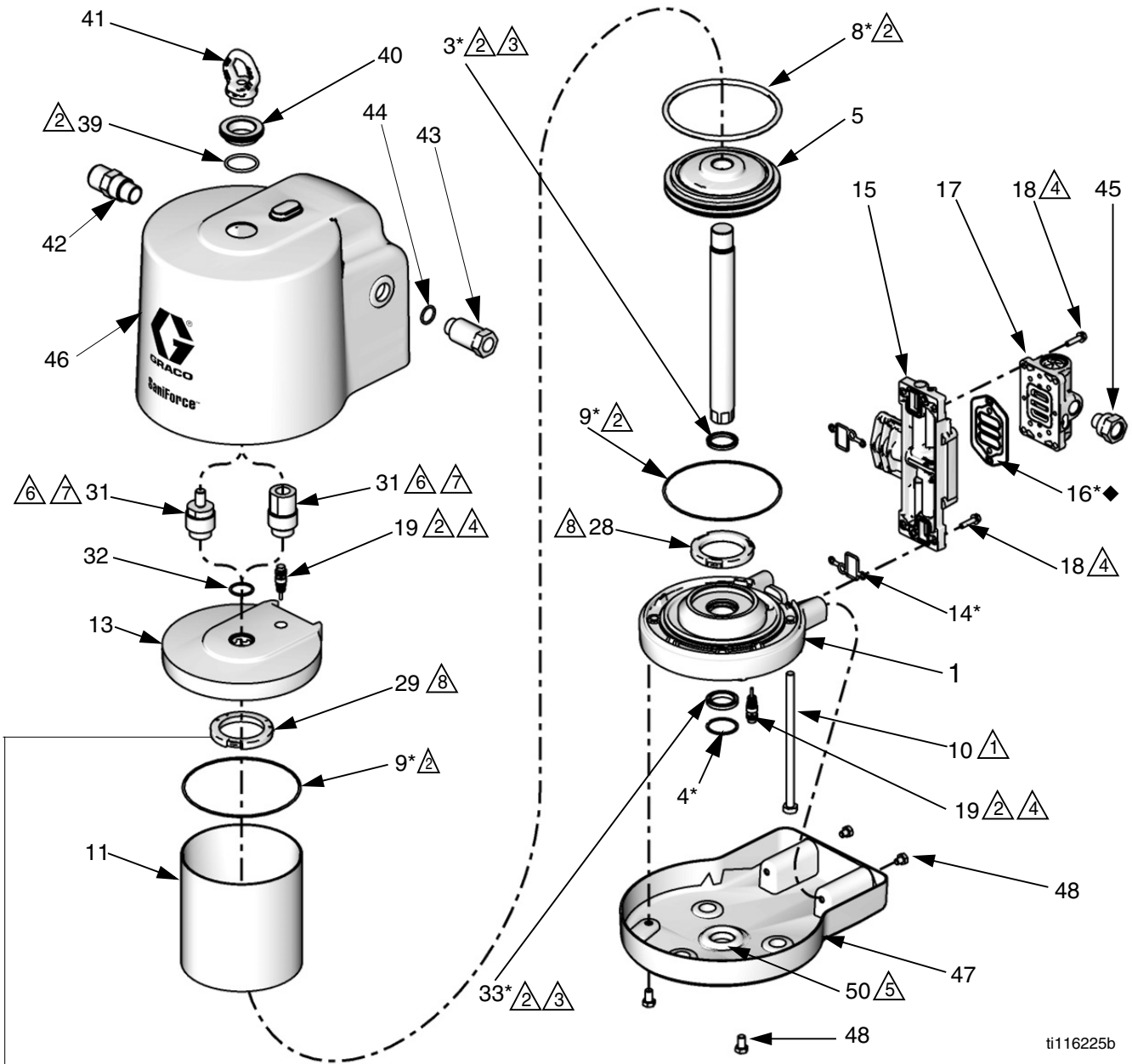

**FIG. 8. Center Grommet Installation**

2. If bottom shroud (47) has been removed, slide it up onto the tie rods (10). Tighten the screws (48).
3. Lower the top shroud (46) over the air motor.
4. Grease and install the o-ring (39), hand screw (40), and lift ring (41), hand tight.
5. Install the air inlet (43) and exhaust (42) fittings tightly with a wrench.

# Parts

## Air Motor Kit, plus Lift Ring, Fittings, Shrouds, and Fasteners



ti116225b

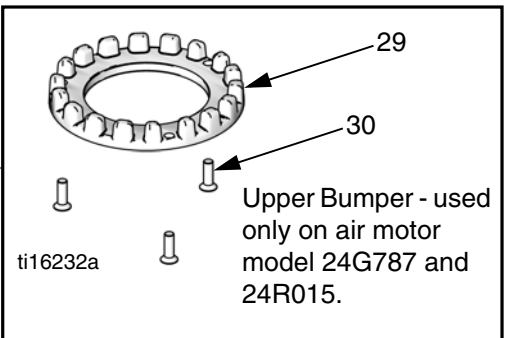

- ⚠️ Torque varies by motor size: Model 24G785: 11-13 ft-lb (15-18 N•m)  
Models 24G786, 24G787, 24R015, 24R491: 25-30 ft-lb (34-40 N•m)
- ⚡️ Apply NLGI No. 1, bentone-based grease.
- ⚠️ U-cup faces up. Flange (bottom seal only) faces down. See FIG. 7, page 12.
- ⚡️ Torque to 95-105 in-lb (11-12 N•m).
- ⚡️ Apply appropriate sanitary lubricant.
- ⚠️ Apply pipe sealant (Models 24R015, 24R491 and 24W754) or lubricant (Models 24G785, 24G786, and 24G787).
- ⚠️ Torque to 30-35 in-lb (41-47 N•m). ⚡️ Press to snap fit.

## Air Motor Parts — All Models

(See page 16 for Shroud Kits, Fittings, and Fasteners, sold separately.)

Ref.	Description	Qty	Model 24G785	Model 24G786	Model 24R491	Model 24G787	Model 24R015	Model 24W754
1	COVER, lower, assembly; includes Refs. 3, 4, 9, 12, 19, 28, and 33	1	24A545	24A549		24A553		24A549
3*	U-CUP	2	Not sold separately. See Air Motor Seal Kit (page 17) or Lower Cover Assembly (Ref. 1, this table)					
4*	RETAINING RING	2	Not sold separately. See Air Motor Seal Kit (page 17) or Lower Cover Assembly (Ref. 1, this table)					
5	PISTON/ROD, assembly; includes Ref. 8	1	16G510	16G513		16G515		16G513
8*	O-RING, piston	1	Not sold separately. See Air Motor Seal Kit (page 17) or Piston Assembly (Ref. 5, this table)					
9*	O-RING, cover	2	Not sold separately. See Air Motor Seal Kit (page 17) or Lower Cover Assembly (Ref. 1, this table)					
10	BOLT, tie, hex head	3 4 6	15M313 ----- -----	----- 15M315 -----		----- ----- 15M315		15M315
11	CYLINDER, motor	1	15X783	16A517		16A516	24P936	16A517
12	SCREW, ground	1	116343	116343		116343		116343
13‡	COVER, upper, assembly, includes Refs. 9, 19, 29, 30, 31, 32	1	16G516	16G517		16G518		16G517
14*	GASKET, manifold	2	Not sold separately. See Air Motor Seal Kit (page 17) or Manifold Assembly (Ref. 15, this table)					
15	MANIFOLD, assembly, includes Refs. 14, 16, and 18 (qty. 4)	1	16G519	16G520		16G521		16G520
16*◆	GASKET, air valve	1	Not sold separately. See Air Motor Seal Kit (page 17), Air Valve Repair Kit (page 18), or Manifold Assembly (Ref. 15, this table)					
17	VALVE, air, assembly; includes Refs. 16 and 18 (qty. 4)	1	24A352	24A352		24A352	24X156	24X156
18	SCREW, M6 x 25	8	Not sold separately. See Manifold Assembly (Ref. 15, this table) or Air Valve Assembly (Ref. 17, this table)					
19	VALVE, pilot	2	24A366	24A366		24A366		24A366
28	BUMPER KIT Lower bumper only Lower bumper, upper bumper, and screws (qty. 3)	1		24A914		24A915		24A914
29	BUMPER, upper	1				Not sold separately.		
30	SCREW, M5, flat head	3				See Bumper Kit (Ref. 28, this table)		

*Continued on next page.*

Ref.	Description	Qty	Model 24G785	Model 24G786	Model 24R491	Model 24G787	Model 24R015	Model 24W754
31	ADAPTER; includes Ref. 32	1	16T537	16T537	16V087	16T537	16G523	16G523
32	O-RING, for adapter	1	110636	110636	110782	110636	110782	110782
33	SEAL, u-cup with flange	1	Not sold separately. See Air Motor Seal Kit (page 17) or Lower Cover Assembly (Ref. 1, this table)					
35▲	LABEL, warning (not shown)		280574	280574		280574		280574

\* Included in Air Motor Seal Kit. See page 17.

◆ Included in Air Valve Repair Kit. See page 18.

‡ The upper cover assembly includes two adapter o-rings. See Ref. 32 for the correct o-ring to use for your motor.

▲ Replacement Warning labels, signs, tags, and cards are available at no cost.

## Shroud Kits, Fittings, and Fasteners\*

(See page 15 for Air Motor parts.)

Ref.	Description	Qty	Model 24G785	Model 24G786	Model 24G787
39	O-RING	1	165053	165053	165053
40	HAND NUT	1	16C306	16C306	16C306
41	LIFT RING (not included with air motors used on rams)	1	16C009	16C009	16C009
42	FITTING, exhaust	1	16C946	16C946	16C946
43	FITTING, air inlet	1	Not sold separately. Order Air Inlet Fitting Kit 24G862.		
44	O-RING, air inlet	1			
45	FITTING, air inlet (normally remains attached to shroud)	1	16G084	16G084	16G084
46	UPPER SHROUD KIT; includes grommets (Ref. 50)	1	16G464	16G381	16G380
47	LOWER SHROUD KIT, includes fasteners (Ref. 48) and grommets (Ref. 50)	1	16G465	16G383	16G382
48	SCREW, cap; M8 x 1.25, sst	4	118134	118134	118134
Order Shroud Fastener Kit 16G432 for quantity of 4					
50	GROMMET				
50a**	Air motor piston rod	1	Not sold separately. Order Grommet Kit 16G628 (3.5 in. air motor) or Grommet Kit 16G385 (6.0 in. or 7.5 in. air motor). Grommets also come with Upper Shroud Kit (Ref. 46) and Lower Shroud Kit (Ref. 47)		
50b	Air fitting	2			
50c	Tie rod	3			

\* For ordering flexibility, Refs. 39-50 are not included when Air Motor Model 24G785, 24G786, 24G787, or 24R491 is purchased. These parts are included when Air Motor Kit with Shroud 24J760, 24J764, or 24J765 is purchased, or when the air motor is purchased as part of a SaniForce Pump Package.

\*\* For qty. 3 of the piston rod grommet, order Kit 16H925 for the 3.5 in. air motor or Kit 16G384 for the 6.0 in. or 7.5 in. air motor.



## Air Motor Seal Kits

Air Motor Model	Air Motor Seal Kit
24G785	16G524
24G786, 24R491, or 24W754	24A547
24G787 or 24R015	24A551

## Model 24A352 Air Valve Parts

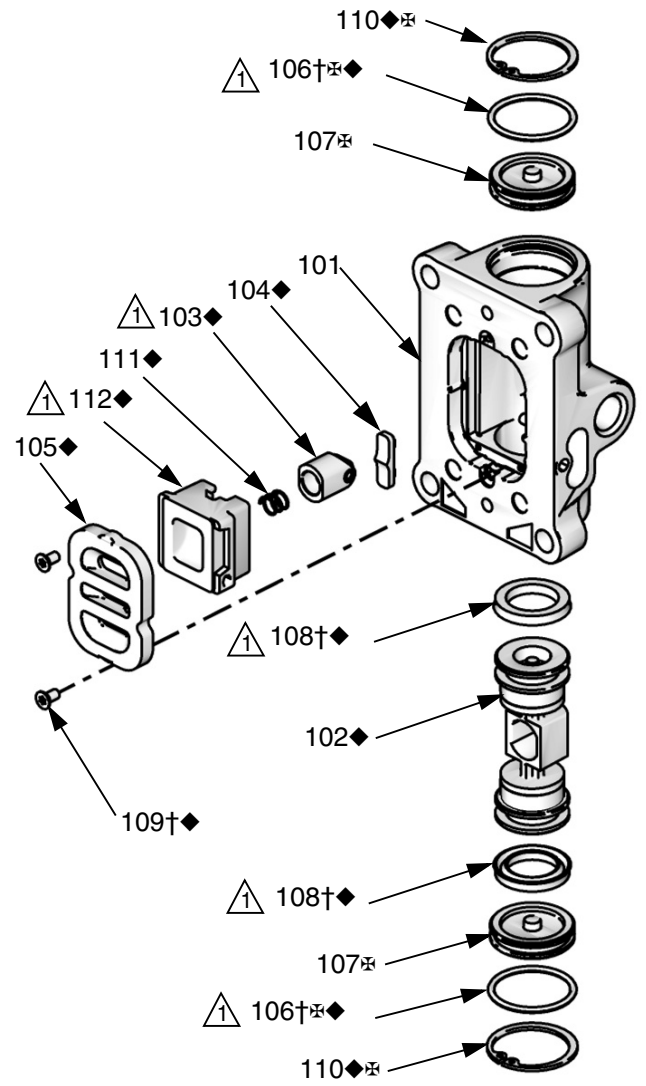

Apply lubricant.

ti11840a

## Air Valve Kits

**NOTE:** Air valve parts are not sold individually. The table below shows possible kit options for each part.

Ref.	Description	Qty.	Air Valve Repair Kit 24A538	Air Valve Seal Kit 24A536	Air Valve End Cap Kit 24A361	Other
101	HOUSING	1				
102◆	AIR VALVE PISTON	1	✓			
103◆	DETENT PISTON ASSEMBLY	1	✓			
104◆	DETENT CAM	1	✓			
105◆	PLATE, air valve	1	✓			
106†⊕◆	O-RING	2	✓	✓	✓	
107⊕	CAP	2			✓	
108†◆	U-CUP	2	✓	✓		
109†◆	SCREW	2	✓	✓		Screws Kit 24A359 (pack of 10)
110◆⊕	SNAP RING	2	✓		✓	
111◆	DETENT SPRING	1	✓			
112◆	CUP	1	✓			
18	SCREW, M6 x 25	4				See Manifold Assembly (Ref. 15, Air Motor Kit Parts table) or Air Valve Assembly (Ref. 17, Air Motor Kit Parts table)
16*†◆	AIR VALVE GASKET	1	✓	✓		See Air Motor Seal Kit (page 17) or Manifold Assembly (Ref. 15, Air Motor Kit Parts table) or Air Valve Assembly (Ref. 17, Air Motor Kit Parts table)

† Included in Air Valve Seal Kit 24A536.

◆ Included in Air Valve Repair Kit 24A538.

⊕ Included in Air Valve End Cap Kit 24A361.

# Dimensions

Air Motor Model	A inch (mm)	B inch (mm)	C inch (mm)	D inch (mm)	E inch (mm)	Weight lb (kg)
<b>24G785</b>	13.7 (348)	16.3 (414)	10.0 (254)	7.7 (196)	9.2 (234)	12.0 (5.4)
<b>24G786</b>	14.5 (368)	18.8 (478)	14.2 (361)	10.9 (277)	11.0 (279)	26.0 (11.8)
<b>24G787</b>	14.5 (368)	18.8 (478)	14.2 (361)	10.9 (277)	11.0 (279)	31.0 (14.1)
<b>24R491</b>	17.8 (452)	22.1 (561)	14.2 (361)	10.9 (277)	11.0 (279)	26.0 (11.8)
<b>24R015</b>	14.5 (368)	18.8 (478)	14.2 (361)	10.9 (277)	11.0 (279)	26.0 (11.8)
<b>24W754</b>	14.5 (368)	18.8 (478)	14.2 (361)	10.9 (277)	11.0 (279)	26.0 (11.8)

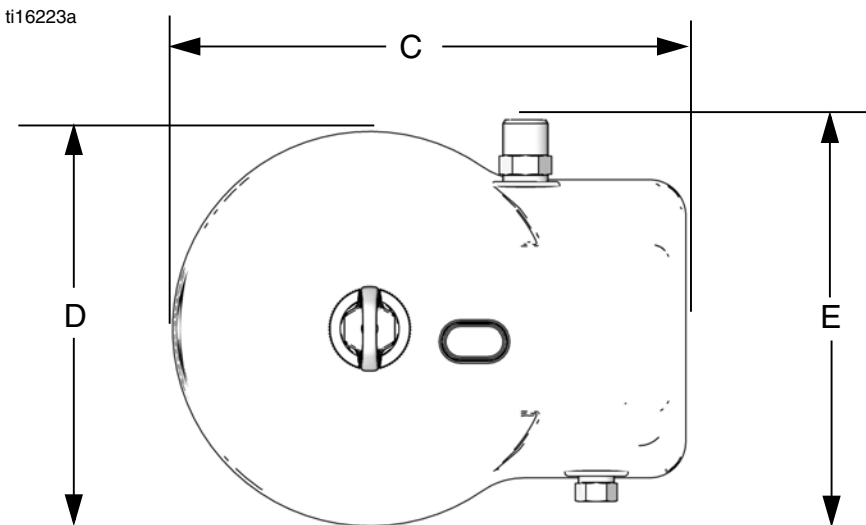
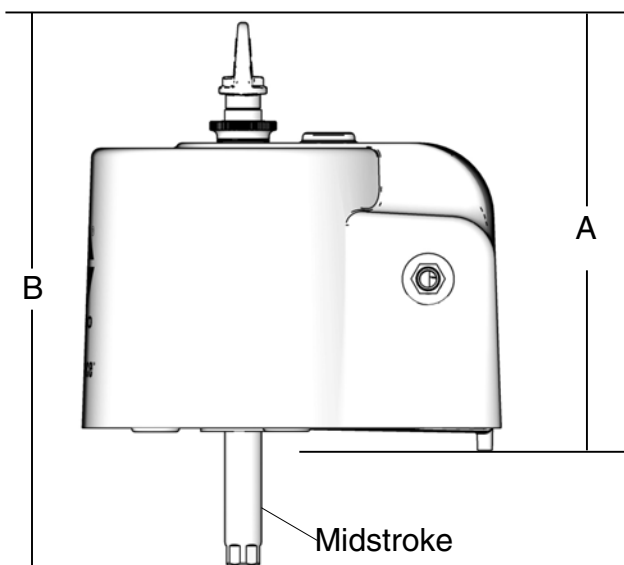



# Technical Data

Maximum air inlet pressure . . . . .	100 psi (0.7 MPa, 7.0 bar)
Stroke length . . . . .	4.75 in.
Air inlet size . . . . .	1/2 in. npt(f)
Air exhaust . . . . .	3/4 in. npt(m)
Maximum motor speed . . . . .	60 cycles per minute

(Do not exceed maximum recommended speed of fluid pump, to prevent premature pump wear.)

Sound data

24G785

Sound power\* . . . . . 78.5 dBA

Sound pressure\*\* . . . . . 71.6 dBA

24G786, 24R491, or 24W754

Sound power\* . . . . . 77.5 dBA

Sound pressure\*\* . . . . . 70.7 dBA

24G787 or 24R015

Sound power\* . . . . . 77.2 dBA

Sound pressure\*\* . . . . . 70.5 dBA

\* Sound power at 70 psi (0.48 MPa, 4.8 bar), 20 cpm. Sound power measured per ISO-9614-2.

\*\* Sound pressure was tested 3.28 feet (1 m) from equipment.

# Graco Standard Warranty

Graco warrants all equipment referenced in this document which is manufactured by Graco and bearing its name to be free from defects in material and workmanship on the date of sale to the original purchaser for use. With the exception of any special, extended, or limited warranty published by Graco, Graco will, for a period of twelve months from the date of sale, repair or replace any part of the equipment determined by Graco to be defective. This warranty applies only when the equipment is installed, operated and maintained in accordance with Graco's written recommendations.

This warranty does not cover, and Graco shall not be liable for general wear and tear, or any malfunction, damage or wear caused by faulty installation, misapplication, abrasion, corrosion, inadequate or improper maintenance, negligence, accident, tampering, or substitution of non-Graco component parts. Nor shall Graco be liable for malfunction, damage or wear caused by the incompatibility of Graco equipment with structures, accessories, equipment or materials not supplied by Graco, or the improper design, manufacture, installation, operation or maintenance of structures, accessories, equipment or materials not supplied by Graco.

This warranty is conditioned upon the prepaid return of the equipment claimed to be defective to an authorized Graco distributor for verification of the claimed defect. If the claimed defect is verified, Graco will repair or replace free of charge any defective parts. The equipment will be returned to the original purchaser transportation prepaid. If inspection of the equipment does not disclose any defect in material or workmanship, repairs will be made at a reasonable charge, which charges may include the costs of parts, labor, and transportation.

**THIS WARRANTY IS EXCLUSIVE, AND IS IN LIEU OF ANY OTHER WARRANTIES, EXPRESS OR IMPLIED, INCLUDING BUT NOT LIMITED TO WARRANTY OF MERCHANTABILITY OR WARRANTY OF FITNESS FOR A PARTICULAR PURPOSE.**

Graco's sole obligation and buyer's sole remedy for any breach of warranty shall be as set forth above. The buyer agrees that no other remedy (including, but not limited to, incidental or consequential damages for lost profits, lost sales, injury to person or property, or any other incidental or consequential loss) shall be available. Any action for breach of warranty must be brought within two (2) years of the date of sale.

**GRACO MAKES NO WARRANTY, AND DISCLAIMS ALL IMPLIED WARRANTIES OF MERCHANTABILITY AND FITNESS FOR A PARTICULAR PURPOSE, IN CONNECTION WITH ACCESSORIES, EQUIPMENT, MATERIALS OR COMPONENTS SOLD BUT NOT MANUFACTURED BY GRACO.** These items sold, but not manufactured by Graco (such as electric motors, switches, hose, etc.), are subject to the warranty, if any, of their manufacturer. Graco will provide purchaser with reasonable assistance in making any claim for breach of these warranties.

In no event will Graco be liable for indirect, incidental, special or consequential damages resulting from Graco supplying equipment hereunder, or the furnishing, performance, or use of any products or other goods sold hereto, whether due to a breach of contract, breach of warranty, the negligence of Graco, or otherwise.

## **FOR GRACO CANADA CUSTOMERS**

The Parties acknowledge that they have required that the present document, as well as all documents, notices and legal proceedings entered into, given or instituted pursuant hereto or relating directly or indirectly hereto, be drawn up in English. Les parties reconnaissent avoir convenu que la rédaction du présente document sera en Anglais, ainsi que tous documents, avis et procédures judiciaires exécutés, donnés ou intentés, à la suite de ou en rapport, directement ou indirectement, avec les procédures concernées.

# Graco Information

For the latest information about Graco products, visit [www.graco.com](http://www.graco.com).

For patent information, see [www.graco.com/patents](http://www.graco.com/patents).

**TO PLACE AN ORDER**, contact your Graco distributor or call to identify the nearest distributor.

**Phone:** 612-623-6921 **or Toll Free:** 1-800-328-0211 **Fax:** 612-378-3505

*All written and visual data contained in this document reflects the latest product information available at the time of publication. Graco reserves the right to make changes at any time without notice.*

Original instructions. This manual contains English. MM 3A1211

**Graco Headquarters:** Minneapolis

**International Offices:** Belgium, China, Japan, Korea

**GRACO INC. AND SUBSIDIARIES • P.O. BOX 1441 • MINNEAPOLIS MN 55440-1441 • USA**

**Copyright 2010, Graco Inc. All Graco manufacturing locations are registered to ISO 9001.**

[www.graco.com](http://www.graco.com)

Revision M, May 2015