

TUNTURI®

OWNERS MANUAL

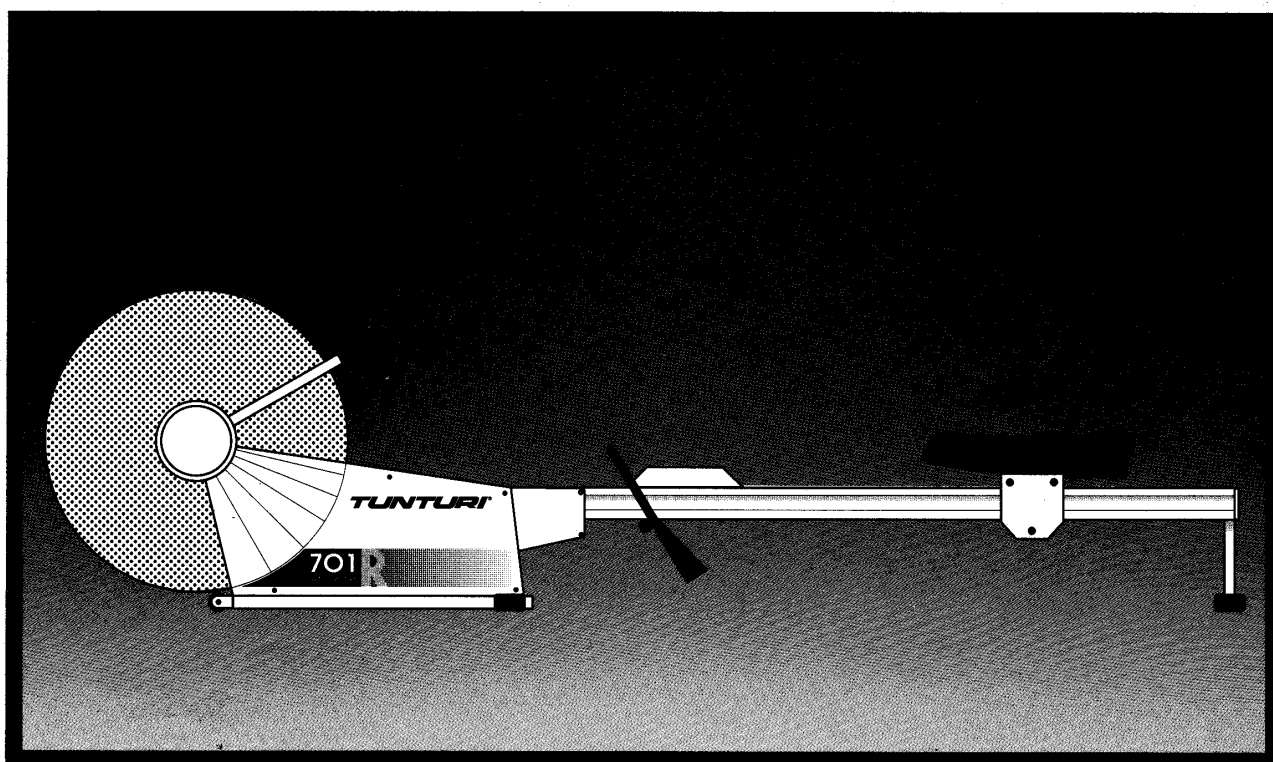

R701 AIR ROWER

INTRODUCTION

Congratulations!

You have selected an excellent piece of exercise equipment. This well-designed machine will provide many years of controlled environment rowing.

With the Tunturi R701 Rowing Machine, you can control the intensity of your workout by the number of strokes you complete per minute. The faster you row, the more air resistance is built up which works against the flywheel fan mechanism. The pulling motion of the Tunturi Air Rower closely simulates the oar action of racing shells. Throughout your workout, the electronics module measures time, speed, distance, and calories burned.

This manual describes everything you need to know to assemble and operate your Tunturi Air Rower. Before you attempt to assemble or operate the rowing machine, read the entire contents of this manual carefully. Being familiar with the machine, its components and capabilities will ensure you receive the maximum benefits offered.

YOUR FITNESS PROGRAM

Rowing is an excellent form of aerobic exercise. The Tunturi R701 Air Rower allows you to maintain a consistent fitness program at any time of the day, in any type of weather.

Rhythmic rowing lets you exercise without putting the entire weight of your body on your legs. Not only will you condition your heart and lungs, but the pull motion of each stroke develops a wide range of muscles in your back, stomach, legs, shoulders, and arms.

Before beginning any exercise program, see your physician and have a complete physical examination. Discuss an appropriate exercise program for your physical condition, weight, and age.

A regular program of aerobic exercise strengthens your heart and circulatory system. To receive the benefits of aerobics, you need to exercise continuously for at least 20 minutes at a pace that elevates your heart rate to 80% of its maximum output. Use the chart below to determine average training pulse rates for various age groups.

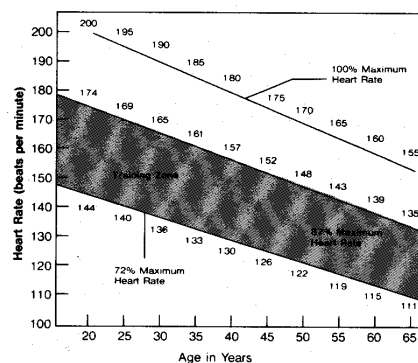

IMPORTANT SAFETY INFORMATION

The Tunturi Air Rower is built for optimum safety. However, certain precautions apply whenever you operate a piece of exercise equipment. Be sure to read the entire manual before you assemble or operate the rowing machine. In particular, note the following safety procedures.

- Never operate the rowing machine near children or pets.
- Always wear proper clothing and shoes when exercising on the rowing machine.
- Keep your back straight during each stroke.
- Consult a physician for a complete examination before beginning any exercise program.
- If you experience dizziness, nausea, chest pains, or other abnormal symptoms, stop your workout at once. Consult a physician before continuing.
- At the beginning of your workout, allow your body to warm up gradually. Remember to cool down after your workout and let your pulse rate return to normal.
- Gentle stretching prior to starting your exercise session will help prevent stiffness or soreness in your legs, arms, and lower back.
- Only *one* person at a time should use the rowing machine.
- Keep hands away from all moving parts.
- Place rowing machine on a solid, level surface when in use.

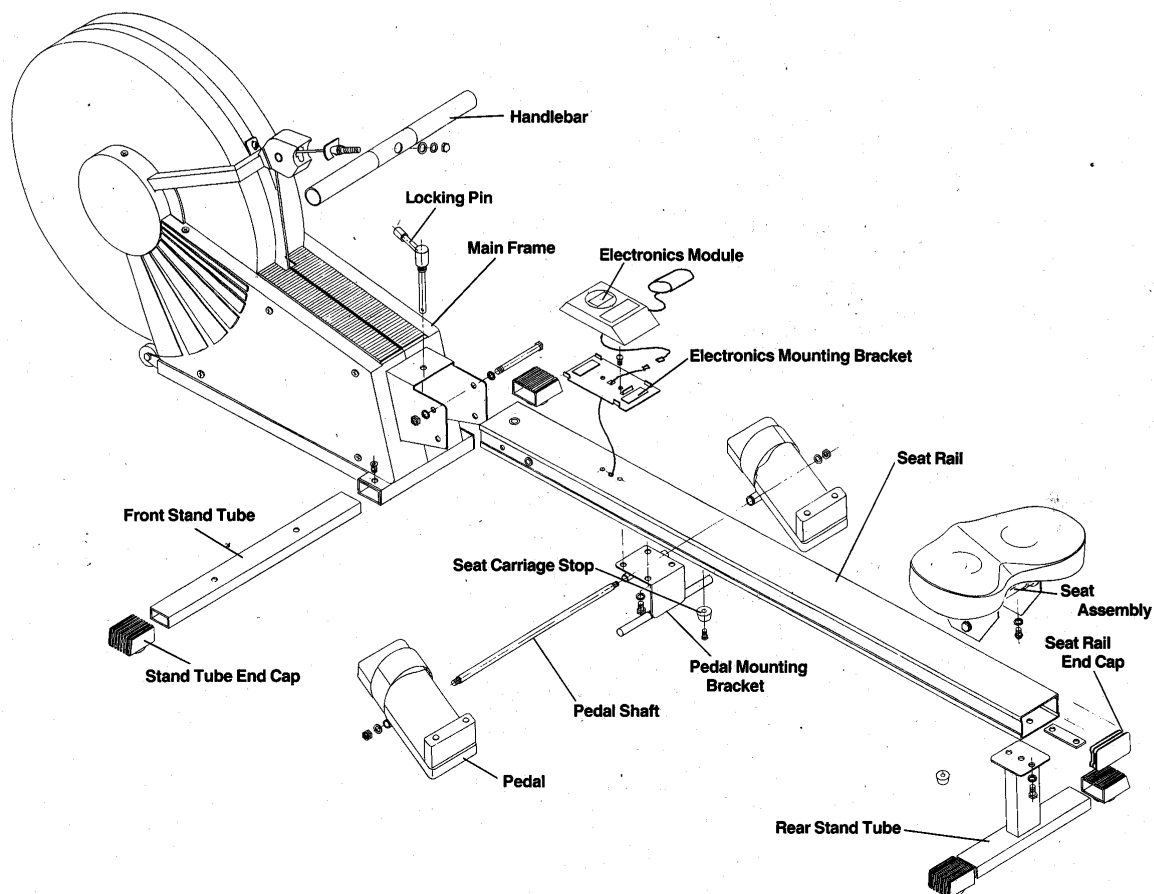

AIR ROWER SETUP AND ASSEMBLY

The Tunturi R701 Air Rower is shipped with the parts and tools required for assembly.

UNPACKING

Cut the straps from the packing and cut the sides of the boxes away from the rowing machine. Slide the parts of the rowing machine out of the boxes and set them on the floor. Refer to the diagram on page 2 to identify all parts.

Make sure the following items were included:

- Electronics module
- Electronics mounting bracket
- Two (2) pedals
- Pedal shaft
- Pedal mounting bracket
- Handlebar
- Seat rail
- Seat rail end cap
- Two (2) Seat carriage stops
- Seat assembly
- Main frame
- Front stand tube
- Rear stand tube
- Four (4) stand tube end caps

- Fasteners and hardware:
 - Two (2) $\frac{5}{16}$ " \times $\frac{1}{2}$ " button head bolts
 - Two (2) $\frac{3}{8}$ " large washers
 - Three (3) $\frac{3}{8}$ " hex head lock nuts
 - Six (6) $\frac{5}{16}$ " \times 1" hex head bolts
 - Six (6) $\frac{5}{16}$ " lock washers
 - Four (4) Phillips head screws
 - One (1) nut plate
 - One (1) $\frac{3}{8}$ " \times $5\frac{1}{2}$ " hex head bolt
 - Two (2) $\frac{3}{16}$ " flat washers
 - One (1) lock pin
 - One (1) $\frac{3}{8}$ " lock washer
 - One (1) hex cap nut
 - Three (3) $\frac{3}{8}$ " small flat washers
- 5mm hex key wrench
- 8-12-13-14-15mm open-end wrench

ASSEMBLY

In all instructions, front, back, right, and left are determined as if you were sitting on the rowing machine.

1. Attach the front stand tube to the main frame.

Slide the front stand tube into the opening in the main frame until the holes in the main frame match the holes in the front stand tube. Use the hex key wrench to secure the front stand tube to the main frame with the two (2) $\frac{5}{16}$ " \times $\frac{1}{2}$ " button head bolts provided. (Refer to illustration #1.) Place an end cap on each end of the front stand tube.

2. Attach the pedals to the seat rail.

First, slide the pedal shaft through the pedal mounting bracket. Next, slide the pedals onto the shaft. Each pedal is identified with an "L" or an "R." Then, place a $\frac{3}{8}$ " large washer and $\frac{3}{8}$ " hex head nut on each side and tighten with the 15mm open-end wrench.

Turn over the seat rail so the bottom is facing up. Use the wrench to secure the pedal assembly to the seat rail with four (4) $\frac{5}{16}$ " \times 1" hex head bolts and (4) $\frac{5}{16}$ " lock washers provided. Use a Phillips screwdriver to attach the front seat carriage stop to the bottom of the seat rail with one Phillips head screw and $\frac{3}{16}$ " flat washer provided. (Refer to illustration #2.)

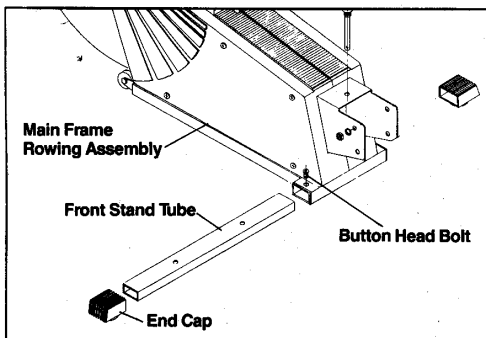

1

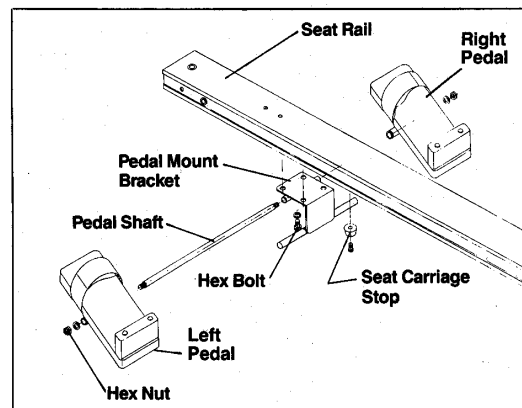

2

3. Slide the seat assembly onto the seat rail. Be sure the notch in the seat points to the rear of the rower. (Refer to illustration #3.)

4. Attach the rear stand tube to the seat rail.

Align the holes in the rear stand tube with the holes in the bottom of the seat rail. Use the 12mm open-end wrench to secure the rear stand tube to the seat rail with two (2) $\frac{5}{16}$ " x 1" hex head bolts and two (2) $\frac{5}{16}$ " lock washers provided. The bolts thread into the nut plate placed inside the rear stand tube. (Refer to illustration #3.) Push the end cap into the end of the seat rail. Place an end cap on each end of the rear stand tube. Use a Phillips screwdriver to attach the rear seat carriage stop to the bottom of the seat rail with one (1) Phillips head screw and $\frac{3}{16}$ " flat washer provided.

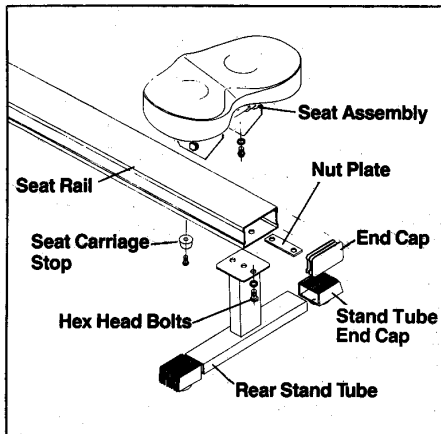

3

5. Attach the seat rail to the main frame.

Position the seat rail on the mounting bracket of the main frame so the holes in the mounting bracket match those in the seat rail. Push the $\frac{3}{8}$ " x $5\frac{1}{2}$ " hex head bolt through the seat rail and mounting bracket. Use the 15mm open-end wrench to tighten the hex head bolt, $\frac{3}{8}$ " flat washer on each side and locking nut. (Refer to illustration #4.)

6. Insert locking pin in the top of the seat rail and tighten. (Refer to illustration #4.)

NOTE: The locking pin can be removed to lift the seat rail upright when moving the rower. See "Transportation" later in this manual.

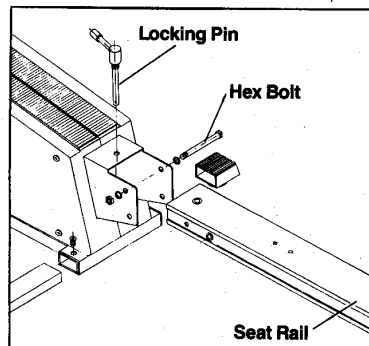

4

7. Feed the electronics cable (taped to the seat rail) through the electronics mounting bracket. Use a Phillips screwdriver to attach the mounting bracket to the seat rail using two (2) Phillips head screws provided.

Insert two (2) size AA 1.5 volt batteries into the electronics module battery holder. The direction of the batteries is indicated inside the battery holder.

Connect the electronics cable to the electronics module. Place the electronics module on the velcro tabs located on the seat rail. (Refer to illustration #5.) Press gently to secure.

8. Attach the handlebar.

Place the handle over the cable bolt with the larger recessed hole facing outward. Place a $\frac{3}{8}$ " washer, lock washer, and hex cap nut on the cable bolt and tighten with the 15mm open-end wrench. Remove the cable retaining plate and discard. (Refer to part no. 39 on exploded diagram on p. 12).

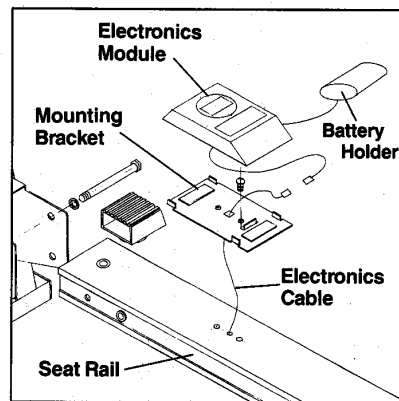

5

OPERATION

The Tunturi R701 Air Rower lets you set an exercise program that meets your specific needs. You should be familiar with the electronics module and its functions before you begin exercising on the rowing machine.

Keys

ON/OFF: Use this key to turn the electronics module on or off. When you turn the power on, a tone will sound and all the symbols in the LCD window will light for three (3) seconds. The rowing speed bar graph (showing strokes per minute) and the ROWING symbol are always displayed when the unit is on.

START/STOP: After turning the electronics module on, press this key to measure your time, strokes, and calories burned.

NOTE: If you want to preset your exercise time, total strokes, exercise tempo, or load, do so before starting the unit. See the MODE and SET keys for instructions.

If you press START/STOP again, time, strokes, and calories are not measured, but the current values are retained in memory until the RESET key is pressed or the unit is turned off. The STOP symbol will appear in the LCD window when you stop the electronics module.

MODE: Use this key to cycle through and display the functions measured by the electronics module. When the unit is in STOP mode, press this key to advance through all the functions: Time, Strokes, Cal/min, CAL, Tempo, and Load. In START mode, this key advances through the Time, Strokes, Cal/Min, and CAL functions.

Scan Function: Hold down the MODE key for 2 seconds to activate the automatic scan function. The time, strokes, Cal/min, and calories functions are each displayed at 5-second intervals throughout your exercise session. The SCAN symbol appears in the display when the scan function is activated.

Time Mode: Tracks the elapsed time of each exercise session from 0 to 99:59 minutes. If you preset your workout time, the timer will count down from 99 to 0 minutes. The time remaining will be displayed in the LCD window (refer to SET key).

Strokes Mode: Tracks the number of strokes during each exercise session from 0 to 9990 strokes. If you preset your strokes, the strokes remaining will be displayed in the LCD window.

Cal/min Mode: Displays the number of calories burned per minute during your exercise session.

Calories Mode: Displays the total number of calories burned during your exercise session.

Tempo Mode: Sets the pace, number of strokes per minute, you want to maintain during your workout. An electronic tone sounds every 0.125 to 9.875 seconds.

Load Mode: Programs the workload (strokes per minute) in order to obtain an accurate calorie readout.

SET: Use this key to preset your exercise time, total strokes, exercise tempo, and the load value when the unit is in STOP mode. Hold down the SET key for 2 seconds to advance the function value you are currently programming at a faster rate. Use the following instructions to program each of the functions.

To preset exercise time:

1. Press the MODE key to advance to the TIME function.
2. Press the SET key to advance the preset time one minute. Continue to press the SET key until the desired time (from 1 to 99 minutes) is displayed in the LCD window. The TIME SET symbol (bell) will appear in the LCD window.
3. Press the START/STOP key. The electronics module will begin to count down in seconds. The time remaining will be displayed in the LCD window. A tone will sound when the preset time reaches zero.

To preset total strokes:

1. Press the MODE key to advance to the STROKES function.
2. Press the SET key to advance the desired strokes 10 strokes. Continue to press the SET key until the desired number of strokes (from 10 to 9990) is displayed in the LCD window. The STROKE SET symbol (((((())) will appear in the LCD window.

3. Press the START/STOP key. The electronics module will begin to count down your strokes. The strokes remaining will be displayed in the LCD window. A tone will sound when the preset strokes reach zero.

To preset exercise tempo:

1. Press the MODE key to advance to the TEMPO function.
2. Press the SET key to advance your desired exercise pace 0.125 seconds. Continue to press the SET key until the desired exercise pace (from 0.125 to 9.875 seconds) is displayed in the LCD window. The TEMPO SET symbol (note) will appear in the LCD window.
3. Press the START/STOP key. A tone will sound in time with the preset tempo value.

NOTE: The most useful tempo settings are between 2 and 4 seconds (30 strokes/minute and 15 strokes/minute). You can calculate your exact strokes per minute by dividing your tempo time into 60 seconds.

To preset the load:

1. Press the MODE key to advance to the Load function.
2. Press the SET key to advance your desired load value (from 1.1 to 6.6). The load value is related to your speed (strokes/min). Refer to the chart below to determine your appropriate load setting.

| LOAD SETTINGS | STROKES/MIN |
|---------------|-------------|
| 0 | 0 |
| 0.9 | 5 |
| 1.0 | 6 |
| 1.7 | 10 |
| 2.0 | 12 |
| 2.5 | 15 |
| 3.0 | 18 |
| 3.4 | 20 |
| 4.0 | 24 |
| 4.2 | 25 |
| 4.5 | 27 |
| 5.0 | 30 |
| 5.5 | 33 |
| 6.0 | 36 |
| 6.5 | 39 |
| 6.6 | 40 |

3. Press the START/STOP key. When the arrow in the LCD window points to Calories or Cal/min you will obtain a correct readout based on the preset load value.

RESET: When you press this key, the value for the function currently displayed returns to zero. Pressing the RESET key also automatically switches the unit to STOP mode.

Hold down the RESET key for two seconds to return all values (except the LOAD value) to zero simultaneously.

LCD Window

When you first turn on the electronics module, the LCD window lights up and you will see a variety of symbols displayed. These symbols indicate that the electronics module is working. The symbols displayed and their significance is described in more detail in the section titled "Keys" above.

A TYPICAL EXERCISE SESSION

Whenever you exercise on the rowing machine, you should follow these procedures:

1. Place one foot in each of the pedals and adjust the pedal straps.

Grasp the outside edges of each velcro strap and pull down to the desired tightness. Fold each strap up and press gently.

2. Preset the desired functions on the electronics module.

For example:

A. Press the ON/OFF key to turn the electronics module on. Make sure STOP is displayed in the LCD window.

B. Press the MODE key to advance to the TIME function.

C. Press the SET key to advance preset time one minute. Continue to press the SET key until the desired time (from 1 to 99 minutes) is displayed in the LCD window.

D. Press the MODE key to advance to the STROKES function.

F. Press the SET key to advance the desired strokes 10 strokes. Continue to press the SET key until the desired number of strokes (from 10 to 9990 strokes) is displayed in the LCD window.

G. Press the MODE key to advance to the TEMPO function.

H. Press the SET key to advance your desired exercise pace 0.125 seconds. Continue to press the SET key until the desired exercise pace (from 0.125 to 9.875 seconds) is displayed in the LCD window.

I. Press the START/STOP key. The electronics module begins to count down the time and strokes you selected. A tone will sound in time with the preset tempo value.

J. Press the MODE key for two seconds to activate the scan function. The electronics module will cycle through the Time, Strokes, Cal/min, and Calories modes in five-second intervals.

3. To begin, reach forward with your knees bent, arms extended, and body leaning toward the flywheel. The drive portion of the stroke involves pushing back and extending the legs. The legs and back should be doing all the work.

4. At the end of the drive, use your arms and shoulders to pull the handlebar into your abdomen. The legs are fully extended and the body is leaning back slightly. The handle should always travel in a straight line toward the abdomen.

5. To begin the recovery portion of your rowing stroke, extend your arms and bend your body forward at the hips. To avoid hitting your knees and hands the handlebar should be in front of your knees as the seat moves forward.

6. Bring your legs and body back to the starting position for the next stroke. You are now ready to start the next drive without ever coming to a complete stop.

7. At the end of each exercise session, slow your strokes to bring your heart rate down to normal.

Storage

The rowing machine should be stored in a location that is dry and free from dust with only a slight variation in temperature. If desired, you can place the seat rail in a vertical position to save storage space.

To place the seat rail in a vertical position:

1. Remove the locking pin from the top of the seat rail.
2. Lift the seat rail to an upright position.
3. Insert the locking pin in the side of the seat rail.

Transportation

You can transport the rowing machine with the seat rail up or down. To transport the rowing machine with the seat rail down, lift the back of the rail and push the rower on the two front wheels.

To transport the rowing machine with the seat rail up, push the rower from the back of the rail using the two (2) front wheels.

Tightening the Pedal Straps

Insert your feet into the pedals. Grasp the outside edges of each velcro strap and pull down to the desired tightness. Fold each strap up and press gently.

Replacing the Batteries

Lift the electronics module from the seat rail. Insert two (2) size AA batteries into the battery holder. Replace the electronics module on the velcro tabs on the seat rail. Press gently to secure.

SPECIFICATIONS

DIMENSIONS/MATERIALS

Length: 93"
Height: 25½"
(Seat folded up) 60"
Width: 19½"
Weight: 72 lbs.
Seat movement: 43"
Frame Material: Steel

FUNCTIONS

Time Range: 0 to 99:59 minutes
Strokes: 0 to 9990
Cal/min: 0 to 99.9
Cal: 0 to 9999
Tempo: 0.125 to 9.875 (480 to 6 strokes/min.)
Strokes/min: 0 to 60 (bar graph display)
Load Range: 1 to 6.6 (preset value is 1)
Batteries: Two (2) 1.5 V AA

PARTS LIST

| REFERENCE NUMBER | DESCRIPTION | QTY./UNIT |
|------------------|----------------------------|-----------|
| 1 | FRAME | 1 |
| 2 | TUNTURI LABEL | 2 |
| 3 | MODEL LABEL (L&R) | 1 SET |
| 38 | PLATE | 1 |
| 39 | CABLE HOLDER | 1 |
| 40 | AXLE ASSY | 1 |
| 41 | BEARING HOUSING | 2 |
| 45 | DRIVE PULLEY ASSY | |
| 42 | FAN BLADE | 6 |
| 47 | SPACER | 2 |
| 48 | ONE WAY BEARING ASSY | 2 |
| 50 | TENSION SPRING ASSY | 2 |
| 53 | CABLE HOUSING | 1 |
| 55 | CABLE | 1 |
| 56 | FAN WHEEL | 1 |
| 57 | CAGE | 1 |
| 58 | TRIM STRIP | 1 |
| 59 | AXLE COVER | 2 |
| 62 | SIDE COVER (L&R) | 1 SET |
| 63 | ELECTRONICS MOUNTING PLATE | 1 |
| 64 | SEAT STOP | 2 |
| 67 | FRONT STAND TUBE | 1 |
| 68 | SLEEVE | 2 |
| 69 | END CAP | 4 |
| 70 | FOOT | 2 |
| 71 | WHEEL | 4 |
| 72 | BOLT | 4 |
| 73 | PULLEY | 1 |
| 74 | BOLT | 1 |
| 75 | HANDLE BAR | 1 |
| 76 | FOAM GRIP | 2 |
| 80 | REAR STAND TUBE | 1 |
| 81 | END CAP | 1 |
| 82 | SEAT BRACKET | 1 |
| 83 | ROLLER ASSY | 3 |
| 85 | WASHER | 6 |
| 86 | BOLT | 3 |
| 87 | NUT PLATE | |
| 88 | PULLEY COVER | 1 |
| 89 | BOLT | |
| 90 | BEAM LABEL | 1 |
| 91 | BEAM ASSY | 1 |
| 95 | LOCKING PIN | 1 |
| 98 | PEDAL MOUNT ASSY | 1 |
| 99 | SLEEVE | 2 |
| 102 | FOOT PEDAL PLATE | 2 |
| 103 | FOOT PEDAL | 2 |
| 104 | FOOT PEDAL STRAP | 2 |
| 111 | ELECTRONICS MODULE | 1 |
| 112 | ELECTRONICS CABLE & SENSOR | 1 |

| REFERENCE NUMBER | DESCRIPTION | QTY./UNIT |
|------------------|------------------|-----------|
| 113 | SEAT | 1 |
| 115 | DRIVE BELT | 1 |
| 128 | SNAP RING | 2 |
| 130 | SOCKET HEAD BOLT | 6 |
| 131 | SOCKET HEAD BOLT | 6 |
| 132 | TENSION ASSY | 2 |
| 136 | WASHER | 4 |
| 137 | SCREWS | 8 |
| 138 | SCREW | 2 |
| 139 | BOLT | 4 |
| 140 | SOCKET HEAD BOLT | 2 |
| 141 | NUT | 3 |
| 142 | NUT | 4 |
| 143 | NUT | 1 |
| 145 | NUT CLIP | 8 |
| 146 | SCREW | 6 |
| 147 | LOCK NUT | 3 |
| 148 | SCREW | 2 |
| 149 | WASHER | 7 |
| 150 | BOLT | 4 |
| 151 | BOLT | 4 |
| 152 | WASHER | 4 |
| 154 | CAP NUT | 1 |
| 155 | LOCK WASHER | 1 |
| 156 | WASHER | 1 |
| 162 | WASHER | 1 |
| 164 | SCREW | 8 |
| 172 | SCREW | 2 |

