

savin

OPERATOR'S MANUAL

3690

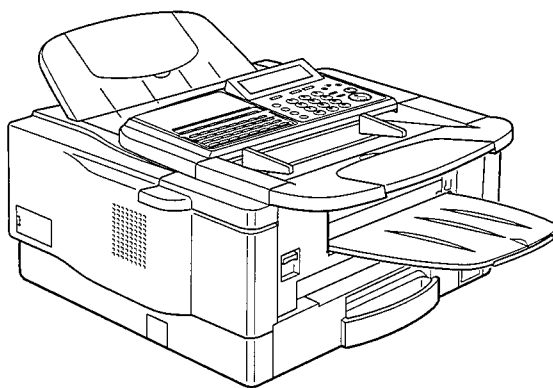

Optional Equipment

Memory (FEATURE EXPANDER TYPE 140 2M, FEATURE EXPANDER TYPE 140 4M, FEATURE EXPANDER TYPE 80M HD)

Either a 2-Mbyte memory card, a 4-Mbyte memory card or a 80-Mbyte hard disk can be added.

ISDN G4 KIT (ISDN INTERFACE TYPE 140)

This allows you to send and receive using the ISDN (Integrated Services Digital Network)

PC Printer Interface Kit (PRINTER INTERFACE TYPE 100)

This allows you to use the machine as a laser printer for an IBM¹ or compatible personal computer.

Telephone Handset (HANDSET TYPE 100)

This permits voice communication (over the PSTN).

PAPER CASSETTE TYPE 100

This gives this machine additional 100 sheet paper capacity with single sheet bypass.

COUNTER TYPE 100

FUNCTION UPGRADE CARD TYPE 140

With this card installed, Memory Disk, Upgraded Speed Dial and so on become available.

FAX ON DEMAND TYPE 140

When installed the Fax on Demand service becomes available.

EXTRA PAPER FEED UNITS

Up to 2 extra paper feed units can be added to the base machine:

PAPER FEED UNIT TYPE 140F - an additional front feed paper unit.

PAPER FEED UNIT TYPE 140S - an additional side feed paper unit.

A front and side feed unit cannot be installed on the same machine.

Note: The Function Upgrade Card and Fax on Demand Kit cannot be installed in the same machine.

1Copyright Notice

IBM is a registered trademark of International Business Machines Corporation.

<p>Caution: Once a Function Upgrade Card or Fax on Demand Card has been installed, do not remove it. If removed, this will result in data being permanently lost.</p>
--

WARNING: This equipment has been tested and found to comply with the limits for a Class A digital device, pursuant to Part 15 of the FCC Rules. These limits are designed to provide reasonable protection against harmful interference when the equipment is operated in a commercial environment. This equipment generates, uses, and can radiate radio frequency energy and, if not installed and used in accordance with the instruction manual, may cause harmful interference to radio communications. Operation of this equipment in a residential area is likely to cause harmful interference in which case the user will be required to correct the interference at his own expense.

* **CAUTION:** Use of control or adjustments or performance of procedures other than those specified herein may result in hazardous radiation exposure.

ENERGY SAVING INFORMATION



As an Energy Star Partner, we have determined that this fax model meets Energy Star guidelines for energy efficiency.

This product was designed to reduce the environmental impact associated with fax equipment. This is accomplished by means of energy saving features such as Low Power (Energy Saver) mode and Night Timer. Please see applicable sections of operating manual for details.

Notice about the Telephone Consumer Protection Act (Valid in the USA only)

Attention please!

The Telephone Consumer Protection Act of 1991 among other things makes it unlawful for any person to send any message via a telephone fax machine unless such message clearly contains in a margin at the top or bottom of each transmitted page or on the first page of the transmission, the date and time it is sent and an identification of the business or other entity, or other individual sending the message and the telephone number of the sending machine or such business, other entity, or individual. This information is transmitted with your document by the TTI (Transmit Terminal Identification) feature.

In order for you to meet the requirement, your machine must be programmed by following the instructions in the accompanying Operation Manual. In particular, please refer to the "Getting Started" and/or "Programming" sections. Also refer to the TTI (Transmit Terminal Identification) programming procedure to enter the business identification and telephone number of the terminal or business. Do not forget to set the date and time.

Thank you

IMPORTANT SAFETY INSTRUCTIONS

1. Read all of these instructions.
2. Save these instructions for later use.
3. Follow all warnings and instructions marked on the product.
4. Unplug this product from the wall outlet before cleaning. Do not use liquid cleaners or aerosol cleaners. Use a damp cloth for cleaning.
5. Do not use this product near water.
6. Do not place this product on an unstable cart, stand, or table. The product may fall, causing serious damage to the product or injuring the user.
7. Slots and openings in the cabinet and the back or bottom are provided for ventilation; to ensure reliable operation of the product and to protect it from overheating, these openings must not be blocked or covered. The openings should never be blocked by placing the product on a bed, sofa, rug, or other similar surface. This product should not be placed in a built-in installation unless proper ventilation is provided.
8. This product should be operated from the type of power source indicated on the marking label. If you are not sure of the type of power available, consult an authorized sales person or your local power company.
9. This product is equipped with a 3-wire grounding type plug, a plug having a third (grounding) pin. This plug will only fit into a grounding-type power outlet. This is a safety feature. If you are unable to insert the plug into the outlet, contact your electrician to replace your obsolete outlet. Do not defeat the purpose of the grounding type plug. (This does not apply in countries in which the 2-wire, non-grounded type of plug is used.)
10. Do not allow anything to rest on the power cord. Do not locate this product where persons will walk on the cord.
11. If an extension cord is used with this product, make sure that the total of the ampere ratings on the products plugged into the extension cord do not exceed the extension cord ampere rating. Also, make sure that the total of all products plugged into the wall outlet does not exceed 15 amperes.
12. Never push objects of any kind into this product through cabinet slots as they may touch dangerous voltage points or short out parts that could result in a risk of fire or electric shock. Never spill liquid of any kind on the product.
13. Do not attempt to service this product yourself, as opening or removing covers may expose you to dangerous voltage points or other risks. Refer all servicing to qualified service personnel.
14. Unplug this product from the wall outlet and refer servicing to qualified service personnel under the following conditions:
 - A. When the power cord or plug is damaged or frayed.
 - B. If liquid has been spilled into the product.
 - C. If the product has been exposed to rain or water.
 - D. If the product does not operate normally when the operating instructions are followed. Adjust only those controls that are covered by the operating instructions since improper adjustment of other controls may result in damage and will often require extensive work by a qualified technician to restore the product to normal operation.
 - E. If the product has been dropped or the cabinet has been damaged.
 - F. If the product exhibits a distinct change in performance, indicating a need for service.

Table of Contents

<i>INTRODUCTION</i>	<i>1</i>
WHAT DOES A FAX MACHINE DO?	1
TELEPHONE LINE PROBLEMS AFFECT FAX COMMUNICATION	1
<i>HOW TO USE THIS MANUAL</i>	<i>2</i>
MANUAL OVERVIEW	2
CONVENTIONS	3
Keynames	3
Displays	3
STORING TELEPHONE NUMBERS	4
STORING NAMES AND LABELS	4
Punctuation Marks and Symbols	5
Shift Key	5
Cursor and Clear Key for Editing	5
IF YOU MAKE A MISTAKE	5
ON/OFF SWITCHES AND USER PARAMETERS	6
On/Off Switches	6
User Parameter Settings	7
<i>GENERAL PRECAUTIONS</i>	<i>13</i>
POWER AND GROUNDING	13
COLD WEATHER POWER-UP	14
THUNDERSTORMS	14
COPY PAPER	15
TONER CARTRIDGES	15
OPERATING PRECAUTIONS	15
GENERAL	16
<i>GUIDE TO COMPONENTS</i>	<i>17</i>
<i>OPERATION PANEL</i>	<i>18</i>
<i>ROUTINE OPERATION</i>	<i>20</i>
SENDING A FAX MESSAGE	20
Precautions Concerning Unacceptable Document Types	20
Transmission Procedure at a Glance	22
Contrast, Resolution, and Halftone Modes	30
Dialing with the Telephone Directory	33
Optional Features for Transmission	34

Immediate Transmission	41
Using the Stamp	43
Redialing	44
RECEIVING FAX MESSAGES	46
Selecting the Reception Mode	46
Substitute Reception	47
TELEPHONE CALLS	49
Making a Telephone Call	49
Answering the Telephone	51
Phoning and Faxing on the Same Call	51
Speaker and Buzzer Volume Adjustments	52

ADVANCED FEATURES

53

NETWORKING	53
Overview	53
What Networking Features Does This Machine Have?	54
Preparing the Machine for Networking Operations	55
Transfer Request	58
Combining Transfer Request with Broadcasting	61
Multi-step Transfer	62
Your Machine as a Transfer Station (Memory Card or Hard Disk Required)	63
Transfer Request by Tonal Signals	63
TRANSMISSION	68
Keystroke Programs	68
Confidential Transmission	73
Auto Document	75
Storing an Auto Document	76
Changing the Contents of Auto Document	79
Erasing an Auto Document or Label	80
Restricting Access to the Machine	82
Tonal Signals	88
Chain Dialing	90
Specified Image Area (Function Upgrade Card Required)	91
Label Insertion	93
Closed Network (Transmission)	94
Protection Against Wrong Connections	95
ECM (Error Correction Mode) and Page Retransmission	96
Batch Transmission Optional (Memory Card or Hard Disk Required)	97
Well Log Transmission	98
RECEPTION	99
Confidential Reception (Memory Card or Hard Disk Required)	99
Memory Lock (Optional Memory Card or Hard Disk Required)	103
Rejection of Messages from Unidentified Senders	108
Authorized Reception	109
Forwarding (Memory Card or Hard Disk Required)	113

Specified Cassette Selection (Optional Paper Feed Unit Required)	119
Wild Cards	123
Reverse Order Printing (Optional Memory Card or Hard Disk Required)	124
Multi-sort Document Reception (Memory Card or Hard Disk Required)	125
Center Mark	129
Checked Mark	130
Reception Time	131
Length Reduction	132
Two in One	133
Closed Network (Reception)	134
OTHER	135
Polling	135
File Management	142
User Function Keys	148
OMR Sheets	151
Saving Energy	161
Night Timer	163
Counters	166
Communication Result Display	166
Entering PC Printer Mode (Printer Interface Required)	167
Copying	168
Dual Access	169
RDS (Remote Diagnostic System)	170
AI Short Protocol	171

REPORTS	172
----------------	------------

AUTOMATICALLY PRINTED REPORTS	172
Report Formats	173
Printing a Sample of Data on the Reports	175
USER-INITIATED REPORTS	176
Descriptions of Available Reports	176
Print the Personal TCR	177

LOOKING AFTER THE MACHINE	181
----------------------------------	------------

LOADING PAPER	181
Loading Paper in the Main Cassette, the Optional Front Paper Feed Unit or Paper Feed Unit	181
Loading Paper in the Optional Side Paper Feed Unit (Optional)	182
CHANGING THE PAPER SIZE	183
Changing the Paper Size in the Main Cassette or the Optional Front Paper Feed Unit	183
Changing the Paper Size in the Optional Side Paper Feed Unit	185
REPLACING THE TONER CASSETTE AND CLEANING PAD	187
Replacement Procedure	187
REPLACING THE STAMP	189

CHANGING THE PAPER SIZE (OPTIONAL CASSETTE)	190
USER MAINTENANCE PROCEDURES	193
User Maintenance Table of Cleaning	193
User Maintenance Procedure of Cleaning	194
Cleaning the Corona Wire	197
User Maintenance Procedure for Replacing	199
The Front Paper Feed Unit	204
The Side Paper Feed Unit	205

<i>SOLVING PROBLEMS</i>	<i>206</i>
--------------------------------	-------------------

DOCUMENT JAMS	206
Clearing a Document Jam	206
Adjusting the Document Feeder	207
COPY JAMS	208
Cassette Entrance	208
Copy Feed Area	209
Copy Jams with the Optional Removable Cassette (Cassette Area)	212
Paper Jams in the Optional Front Paper Feed Unit	213
Paper Jams in the Optional Side Paper Feed Unit	214
COMMUNICATION PROBLEMS	215
OPERATING DIFFICULTIES	216
DISPLAYED ERROR MESSAGES	220
ERROR CODES	222
CALLING AN AUTHORIZED SERVICE REPRESENTATIVE	224
DEDICATED TRANSMISSION PARAMETERS	224

<i>SPECIFICATIONS</i>	<i>225</i>
------------------------------	-------------------

<i>APPENDIX A</i>	<i>226</i>
--------------------------	-------------------

PROGRAMMING FAX ON DEMAND (OPTIONAL FAX ON DEMAND KIT REQUIRED)	226
Storing and Labeling a Document	226
Editing Documents	228
Erasing a Fax on Demand Document or its Name	229
PRINTING A FAX ON DEMAND LIST	230
PRINTING A FAX ON DEMAND DOCUMENT	230
STORING THE FAX ON DEMAND RECORDED MESSAGES	231
Recording a Message	231
How Callers Use Fax on Demand	233
PRINTING FAX ON DEMAND INFORMATION SERVICE REPORT	234

<i>APPENDIX B</i>	235
--------------------------	------------

DISK FILES (HARD DISK AND FUNCTION UPGRADE CARD REQUIRED)	235
Reception to Disk File	235
Switching Reception to Disk File On/Off	235
Programming a List of Senders to Treat Differently	236
Choosing How to Treat the Programmed Senders	237
Erasing Disk Files	238
Erasing a File	243
PRINTING DISK FILES	244
Printing a List	244
Print a Document	249

<i>APPENDIX C</i>	250
--------------------------	------------

PAPER FEED UNIT	250
Operation	250
Maintenance	250
Copy Jams	250

<i>APPENDIX D</i>	251
--------------------------	------------

FEATURE EXPANDER TYPE 140 80 MB HD	251
General	251
Operation	251

<i>APPENDIX E</i>	252
--------------------------	------------

ISDN TYPE 140	252
Introduction	252
Setting up the Group 4 Interface	253
Operation	257
Troubleshooting	264

<i>APPENDIX F</i>	265
--------------------------	------------

INSTALLING THE MACHINE	265
Location	265
Attaching the Document Table and Document Tray	266
Installing the Machine Cover	267
Installing the Photoconductor, Cleaning Pad and Toner Cassette	268
Rotatable Operation Panels	270
Connecting the Machine	271
Loading Paper in the Cassette	272
Installing Removable Cassette and Loading Paper (Option)	274
Attaching the Optional Handset	277

Installing Optional Memory Card, Function Upgrade Card, and Fax on Demand	277
Using Manual Feed	278
BEFORE YOU SEND YOUR FIRST FAX	279
Some Items Must be Programmed First	279
QUICK DIAL, SPEED DIAL, AND GROUP DIAL	285
Three Convenient Ways to Dial	285
Programming Quick Dial	287
Programming Speed Dials	290
Programming Groups	294
Programming/Changing Upgraded Speed Dials	299
Storage Capacity for Telephone Numbers	303
DEALING WITH JUNK FAX MAIL	305
OTHER ITEMS TO PROGRAM AT YOUR LEISURE	305
GLOSSARY	306

INTRODUCTION

Thank you for purchasing this product. This multi-function office machine offers a wide range of fax, printer, and convenience features. (Some of these features are optional)

WHAT DOES A FAX MACHINE DO?

When you write a letter, you normally seal it in an envelope, attach a stamp, and post it in the nearest mail box. Then, in a few days, depending on the postal service, the letter will arrive at its destination. However, you may not be aware of its arrival until you get a return letter.

A fax machine speeds up this process. After you have written your letter, place it face down in your fax machine's document feeder, dial the destination's fax number, then press the Start key.

The fax machine scans your letter, and converts it into a series of black and white dots (the number of dots that there are across and down the page depends on the resolution that you selected; refer to the specifications section of this manual for details). This series of dots is transformed into an electrical signal and sent out over the telephone line to the destination fax machine.

The receiving fax machine reconstructs your letter from the incoming signal, and prints it.

If you are worried about whether the message arrived at the destination, you can check a report called the TCR (Transaction Confirmation Report). When you print this report, you will see the results of the most recent fax communications made by your machine.

You can use your fax machine to send and receive many types of documents, even photographs.

TELEPHONE LINE PROBLEMS AFFECT FAX COMMUNICATION

Quick and accurate transmission of fax messages depends on the condition of the telephone line. If the line condition is very good, this machine will transmit a letter-size page in about 6 seconds. However, if the line is noisy, the speed may be reduced significantly, and the data may be damaged.

The symptoms of data loss caused by a noisy telephone line are seen on the printouts of received messages. An example is shown opposite. Note that lines are missing from the page at the indicated locations. ECM (Error Correction Mode) is an effective countermeasure against this type of error; you have the choice of having the ECM feature switched on or off. It is switched on before the machine leaves the factory. (Refer to page 96 for more information about ECM).

The line condition is affected by the weather; thunderstorms can cause electrical noise on telephone lines.

In addition, the quality and condition of switching equipment used by your phone company can affect fax communication.

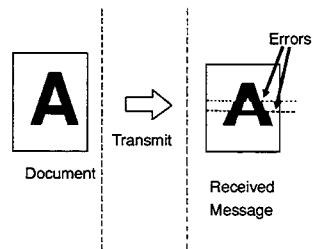

HOW TO USE THIS MANUAL

MANUAL OVERVIEW

Your facsimile machine is equipped with a wide range of labor-saving and cost-saving features. This manual explains each of these features, and how you can put them to use. Note that the external appearance of the machine in some illustrations may be slightly different from the actual machine.

The manual consists of the following sections.

- How to Use this Manual** - This is the section that you are now reading. It contains an overview of the manual and the conventions used by the authors. It also contains quick reference sections on how to input telephone numbers and names, and how to correct errors that you may inadvertently make when operating the machine.
- General Precautions** - This section lists precautions that you should keep in mind when operating the machine. Read this section before you begin to use your machine.
- Guide to Components** - This contains a diagram that shows where the main components of your machine are situated.
- Operation Panel** - This describes the functions of the various buttons and indicators that are on your machine's operation panel.
- Before you Send your First Fax** - This section explains the things that you have to do before you can send your first fax message and lists important features that will make faxing more convenient.
- Routine Operation** - This section describes the features and settings that you will normally be using every day.
- Advanced Features** - This section explains how to take advantage of the special features of your fax machine, including how to set up networks for economical distribution of fax messages over long distances.
- Reports** - This section explains the reports that the machine generates.
- Looking After the Machine** - This section shows you what to do when consumable supplies run out. The user maintenance procedure in this section should be done every six months if you want to keep your machine in top condition.
- Solving Problems** - If your machine cannot communicate, or if it generates error codes or experiences paper jams, refer to this section. Many routine problems can be solved without a service call.
- Specifications** - This is a list of technical capabilities of your machine.
- Appendices A to E** - These describe fax on demand, memory disk file, the paper feed unit the ISDN G4 kit and the hard disk.
- Appendix F Installing the Machine** - This section explains how to install the machine and connect it to the telephone line. It also explains the best type of place to install your machine.
- Quick Reference Guide** - This indicates how to use this machine at a glance.

CONVENTIONS

The following conventions were used when writing this manual.

Keynames

These have been printed in a bold typeface.

For example: When you see a command in bold such as "**Start** " means "Press the Start key on the operation panel".

If you see something like "**# x 3**", this means that you have to press the # key 3 times.

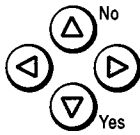

On the operation panel, there are four arrow keys (up, down, left, right). This is the scroll key. It is often used in the operating procedures to gain access to various features. For example, if you see ► in the manual, you are being asked to press the right-pointing arrow (►) on the scroll key.

Displays

Messages seen on the display are shown in a larger box, normally on the right hand side of the page, directly opposite the step that brought it up on the screen. After following a step in a procedure, check the display to see if it corresponds to the one in the manual. This may help you to check whether you are following the procedure successfully. The following examples show three common types of display.

Example A: The keys that can be pressed are shown on the screen in small boxes. In this example, you can press the Yes, No, or Clear keys or down arrow (▼) on the scroll key.

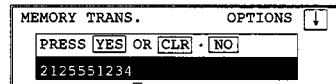

Example B: The choices of settings for a feature are shown on the screen. The current setting is indicated (it is set ON). If you press the ◀ or ▶ on the scroll key, the setting will be changed to OFF.

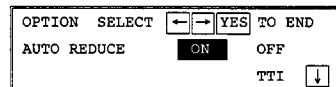

Example C: The ABC in the bottom right of the display indicates letters (using the Quick Dial Keys) or numbers (using the ten-key pad on the operation panel) can be entered.

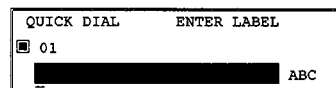

Most procedures start from standby mode, that is, when the display is as shown on the right. The value after "MEMORY" shows how much memory space is remaining.

MEMORY TRANS.	APR. 4. 12:12PM
SET DOC. OR ENTER FAX NO.	
	MEMORY 100%

NOTE: If you start a procedure and do not enter anything at the operation panel for more than 5 minutes, the machine returns to standby mode.

STORING TELEPHONE NUMBERS

To dial a telephone number or store it as a Quick Dial or Speed Dial, type it into the machine at the ten-key pad on the operation panel.

STORING NAMES AND LABELS

You can enter names using the Quick Dial Keys. Use Quick Dial Keys 01 to 26 for the letters of the alphabet (or 33 to 58 if the quick dial label plate on the operation panel is flipped up), and use Quick Dial 30 (or 62) as a spacebar. The letters are printed on the surface of each key. If you wish to enter a digit, use the ten-key pad.

The cursor appears on the screen as a black dash below the cursor position. If you wish to move the cursor while editing a name or number, press the ◀ and ▶ arrows on the circular scroll key on the operation panel.

If you wish to enter a punctuation mark or symbol, use Quick Dial 31 (or 63). See "Punctuation Marks and Symbols" on the next page for more details.

Quick Dial 32 (or 64) can be used as a Shift key, to select upper or lower case letters.

KEY	DESCRIPTION	KEY	DESCRIPTION	KEY	DESCRIPTION
01/33	A	12/44	L	23/55	W
02/34	B	13/45	M	24/56	X
03/35	C	14/46	N	25/57	Y
04/36	D	15/47	O	26/58	Z
05/37	E	16/48	P	27/59	Not used
06/38	F	17/49	Q	28/60	
07/39	G	18/50	R	29/61	
08/40	H	19/51	S	30/62	Space
09/41	I	20/52	T	31/63	Punctuation Marks and Symbols
10/42	J	21/53	U		
11/43	K	22/54	V	32/64	Shift key (see p. 5)

Punctuation Marks and Symbols

If you press **31** or **63** while entering a label, a menu of symbols will appear, as shown on the right.

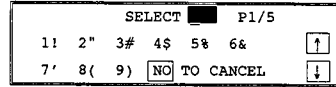

- To select a symbol, press the required key on the ten-key pad. For example, if you wish to enter a '#', press **3**. The cursor moves forward automatically so that you can enter the next letter, digit, or symbol in the item that you are typing into the display.
- If the symbol that you need is not on the screen, scroll through the pages of symbols with the **▲** and **▼** keys.

Shift Key

As shown in example C on page 3, 'ABC' can be seen in the bottom right of the display while you are inputting a label. This indicates that upper case letters will be stored. If you wish to input lower case letters, press **32** or **64**. The 'ABC' will change to 'abc', and the letters that you type in will be stored as lower case letters. To change back to upper case letters, press **32** or **64** again.

Cursor and Clear Key for Editing

You can move the cursor using the scroll key (**◀** and **▶**) to edit the name or label. If you press **Clear**, the character above the cursor is deleted. On entering a character, the character appears at the cursor position then the cursor moves to the right.

IF YOU MAKE A MISTAKE

If you make a mistake when inputting a name or number, either:

- Press **Clear** to erase the last letter or digit that you entered.

If you enter the wrong function number, either:

- Press **No** then input the correct function number.
- Press **Function** to return to standby mode and start again.
-

If you dialed the wrong number, either:

- Press **No**. If scanning has already begun, press **Stop**.
- If you already programmed the number into the machine by pressing Yes, remove the document from the document feeder and start again, or use the destination reviewing feature (option 07) to cancel that particular destination only (see page 52).

ON/OFF SWITCHES AND USER PARAMETERS

Some of the features in this machine can be switched on or off, and some of them do not work unless they are switched on first. Other features can be adjusted in various ways. Each adjustment or on/off switch is explained in the relevant sections of the manual.

There are two user functions to help you access these features.

Function 62 (On/Off Switches)

Function 63 (User Parameters)

On/Off Switches

This feature allows you to switch some of the major features of the machine on or off. The overall procedure is explained below. However, each of the adjustments that can be made using this procedure are explained in the relevant parts of the manual.

1. **Function 6 0 2 2 2 6 and 2.**

PSTN LINE TYPE	SELECT	←	→
DP	TT		↑
	YES	TO END	↓

2. Change the setting by using ◀ and ▶.
The first displayed item is the telephone line type: DP = Pulse Dial, TT = Touch Tone. In the above display, TT is currently selected.

PSTN LINE TYPE	SELECT	←	→
DP	TT		↑
	YES	TO END	↓

3. **Yes.**

AUTHORIZED RECEPTION SELECT	←	→
ON	OFF	↑
	YES	TO END ↓

4. Either:
 - Change another setting: Go to step 5.
 - Finish: **Function**
5. Scroll through the list of features with ▼ until the required feature appears.
Example: Power Saver press ▼ once.

POWER SAVER	SELECT	←	→
ON	OFF		↑
	YES	TO END	↓

6. Go to step 2.

POWER SAVER	SELECT	←	→
ON	OFF		↑
	YES	TO END	↓

On/off switches available in this menu are

	Feature		Feature
1	PSTN Line Type	7	Memory Lock ¹
2	Authorized Reception	8	Forwarding ¹
3	Power Saver	9	Multi-sort Reception ¹
4	Daylight Saving Time/Summer Time	10	Disk Filing ²
5	RDS	11	Cassette Selection ³
6	File Retention Time ¹		

(¹: Optional Memory Card or Hard Disk required. ²: Optional Function Upgrade Card and Hard Disk required, ³: Optional Paper Feed required.)

HOW TO USE THIS MANUAL

User Parameter Settings

A wide range of features can be switched on or off by using the User Parameters. However, this feature is more difficult to use than the On/Off Switches. The switches and adjustments are presented on the screen as rows of digits. Each digit can be either 0 or 1. Each feature is allocated one or more digit. The value of the digit determines the status of the feature.

The overall procedure is explained below. However, each of the adjustments that can be made using this procedure are explained in the relevant parts of the manual.

1. Function 6 0 2 2 2 2 6 and 3.

- At this time, you can print a User Parameter List if you press **▶** and **Start**. The current settings for switch 00 are now displayed on the bottom line of the display. If the settings for this switch are the way that you want them, go to step 3.

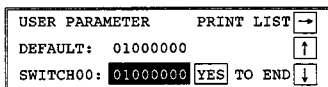

- 2.** To change the required setting, press a number from 0 to 7 corresponding to the digit that you wish to change.

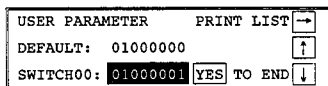

Example: **0** on the ten key pad. The value of the digit changes, in this case from 0 to 1.

Each switch contains 8 digits, which act as on/off switches for various features. The digits are numbered from 7 to 0; the setting of digit 7 is shown at the left side of the display and digit 0 is at the right.

3. Either:

- Scroll through the switches with ▲ and ▼ until the required switch appears. Then go to step 2.
- Finish: **Yes** and **Function**.

The user parameter switches are outlined below.

*: Default

Switch 00 - Home position settings

Digit	Purpose								
0	Stamp				0: Off *				
	1: On (successfully scanned documents will be marked)								
1	Contrast home position								
2	Digit 3	Digit 2	Digit 1	Setting	Digit 3	Digit 2	Digit 1	Setting	
3	0	0	0	Normal *	1	X	X	Do not use this setting.	
	0	0	1	Lighten					
	0	1	0	Darken					
4	Resolution		Digit 5	Digit 4	Setting		Digit 5	Digit 4	Setting
5			0	0	Standard*		1	0	Fine
			0	1	Detail		1	1	Do not use this.
6	Transmission mode				0: Memory transmission*				
					1: Immediate transmission				
7	Halftone				0: Off*		1: On		

Switch 01

Digit	Purpose
0 to 6	Do not change these settings.
7	If you change any of the contrast, resolution, transmission mode, stamp, or halftone settings before making a transmission, then: 0: The setting(s) will not return to the home position after the transmission. 1: The setting(s) will return to the home position after the transmission.*

Switch 02 - Printing of various items on received messages

Digit	Purpose	
0	Mark to be printed at the receiving side to distinguish messages that are sent from your machine when it is acting as a forwarding station (Memory card or hard disk required)	
	0: Off	1: On * Forwarding Mark 
1	Center mark	0: Off* 1: On
	The center mark is not printed when the machine is used for making copies	
2	Reception time	0: Off* 1: On
3	TSI printing	0: Off* 1: On
4	Checked mark	0: Off 1: On*
5	Printing of the Command Information Line (ISDN kit required)	
	0: Off 1: On*	
	This has the same effect as the TTI On/Off setting.	
6	Printing the Terminal ID (ISDN kit required)	
	0: Off* 1: On	
7	Do not change this setting.	

Switch 03 - Automatic printing of reports

Digit	Purpose	0: Off	1: On*
0	Communication result report (memory transmission)	0: Off	1: On*
1	Do not change this setting.		
2	File reserve report (Memory storage report)	0: Off*	1: On
3	File reserve report (polling reception)	0: Off*	1: On
4	Communication result report (polling reception)	0: Off	1: On*
5	Transmission result report (immediate transmission)	0: Off	1: On*
6	Polling clear report	0: Off	1: On*
7	TCR	0: Off	1: On*

HOW TO USE THIS MANUAL

Switch 04 - Automatic printing of reports, Various

Digit	Purpose	0: Off	1: On*
0	Confidential reception report	0: Off	1: On*
1	Fax on demand report	0: Off*	1: On
2 to 6	Do not change these settings		
7	Inclusion of part of the image on the following reports: Transmission Result Report, Memory Storage Report, Polling Clear Report, Communication Failure Report, Transfer Result Report, Transmission Deadline Report, Polling Confirmation List 0: No 1: Yes*		

Switch 05 - Various

Digit	Purpose	0: Off	1: On*
0	Substitute reception	0: Off	1: On*
1	Memory reception if no RTI or CSI received	0: Possible*	1: Not possible
2, 3	Do not change these settings		
4, 5	Restricted Access	Digit 5 Digit 4 Setting	
		0 0 Off*	
		0 1 On	
		1 0 On when the Night Timer is on	
6, 7	Energy Saver mode	Digit 7 Digit 6 Setting	
		0 0 Heater off	
		0 1 Heater energy saver mode*	
		1 X Do not use these settings	

Switch 06 Home position

Digit	Purpose	0: Off	1: On*
0	Printing TTI or CIL on the message to the other side.	0: Off	1: On*
1	Do not change this setting		
2	Closed network in transmission	0: Disabled*	1: Enabled
3	Do not change these settings.		
4	Batch Transmission (Memory card or hard disk required)	0: Off	1: On*
5	Specified Image Area home position	0: Off*	1: On
6 to 7	Do not change these settings.		

Switch 07 - Various

Digit	Purpose		
0, 1	Do not change these settings.		
2	Dialing while a message is stored in. (Parallel memory TX)	0: Off	1: On*
3	Auto Reduce	0: Off	1: On*
4 to 5	Do not change these settings.		
6, 7	Fax on Demand		
	Digit 7	Digit 6	Setting
	0	0	Off*
	1	0	The other party is required to enter the password to access the fax on demand service.
	0	1	The other party is not required to enter the password to access the fax on demand service.

Switch 08 - Various

Digit	Purpose		
0, 1	Multicopy reception (Memory card or hard disk required)		
	Digit 1	Digit 0	Setting
	X	0	Off*
	0	1	Messages from senders whose RTI/CSI/G4 TIDs are programmed are multi-copied.
	1	1	Messages from senders whose RTI/CSI/G4 TIDs are not programmed are multi-copied.
2, 3	Authorized Reception		
	Digit 3	Digit 2	Setting
	X	0	Off *
	0	1	Receive messages only from senders whose RTI/CSI/G4 TIDs are programmed.
	1	1	Receive messages only from senders whose RTI/CSI/G4 TIDs are not programmed .
4, 5	Specified Paper Cassette Selection (Optional Paper Cassette Unit Required)		
	Digit 5	Digit 4	Setting
	X	0	Off*
	0	1	Messages from senders whose RTI/CSI/G4 TIDs are programmed are printed from a upper cassette.
	1	0	Messages from senders whose RTI/CSI/G4 TIDs are not programmed are printed from a upper cassette.
6, 7	Forwarding (Memory card or hard disk required)		
	Digit 7	Digit 6	Setting
	X	0	Off*
	0	1	Forward messages only from senders whose RTI/CSI/G4 TIDs are programmed
	1	1	Forward messages only from senders whose RTI/CSI/G4 TIDs are not programmed .

Switch 09 - Various

Digit	Purpose			
0, 1	Memory lock (Memory card or hard disk required)	Digit 1	Digit 0	Setting
		X	0	Off*
		0	1	Messages from senders whose RTI/CSI/G4 TIDs are programmed are not printed unless you enter the memory lock ID.
		1	1	Messages from senders whose RTI/CSI/G4 TIDs are not programmed are not printed unless you enter the memory lock ID.
2, 3	Disk File (Optional Hard Disk and Function Upgrade Card are required)	Digit 3	Digit 2	Setting
		X	0	Off*
		0	1	Messages from senders whose RTI/CSI/G4 TIDs are programmed are stored in the memory disk.
		1	1	Messages from senders whose RTI/CSI/G4 TIDs are not programmed are stored in the memory disk.
4 to 7	Do not change these settings.			

HOW TO USE THIS MANUAL

Switch 10 Various

Digit	Purpose	
0	Reverse order printing (Memory card or hard disk required)	0: Off* 1: On
1	Two in one	0: Off* 1: On
2 to 6	Do not change these settings	
7	Half tone mode	0: Standard Mode* 1: Speed Mode

Switch 11 Various

Digit	Purpose	
0	Transfer Request by Tonal Signals	0: Off* 1: On
1	Selecton of tone (PB) or UUI after tone(*) (When the ISDN kit is installed)	0: UUI 1: Tone*
2 to 5	Do not change these settings.	
6	Print the received message when it is acting as a forwarding station.	0: Off 1: On*
7	Polling standby duration	0: Once* 1: Keep

Switch 12 Various

Digit	Purpose																		
0 and 1	Do not change these settings.																		
2	<p>Toner saving mode 0: Off* 1: On</p> <p>Note: If on, contrast will be set to "Normal" automatically, preserving image quality. This is available when receiving fax messages and printing reports, but not for copying or printing from a PC.</p> <p>Further, messages sent to you in halftone mode will automatically turn off toner saving to insure a clear image.</p> <p>To make sure that the fax quality is acceptable with toner saving on, print a few reports. (See page 176).</p> <p>(Note: If the sender is using a machine made by another manufacturer, toner saving will stay on and this could lower image quality.)</p>																		
3 and 4	<p>Density of the printing image</p> <table border="1"> <thead> <tr> <th>Digit 4</th> <th>Digit 3</th> <th>Setting</th> <th>Digit 4</th> <th>Digit 3</th> <th>Setting</th> </tr> </thead> <tbody> <tr> <td>0</td> <td>0</td> <td>Normal *</td> <td>0</td> <td>1</td> <td>Lighten</td> </tr> <tr> <td>1</td> <td>0</td> <td>Darken</td> <td>1</td> <td>1</td> <td>Do not use these settings</td> </tr> </tbody> </table>	Digit 4	Digit 3	Setting	Digit 4	Digit 3	Setting	0	0	Normal *	0	1	Lighten	1	0	Darken	1	1	Do not use these settings
Digit 4	Digit 3	Setting	Digit 4	Digit 3	Setting														
0	0	Normal *	0	1	Lighten														
1	0	Darken	1	1	Do not use these settings														
5 to 6	Do not change these settings.																		
7	Copying 0: Possible 1: Not Possible*																		

Switch 13 Do not change these settings

Digit	Purpose
0 to 7	Do not change these settings.

Accessing Previously Used Functions

When you press Function, the names of the last four functions you have used come up in order on the display. This allows you to easily select a function that you have recently used.

Note: If you want to re-use functions 61 and above, you will still need to enter the access code (2222) and function number after following the procedure below.

1. Press **Function**.

The names of the last 2 functions are displayed.

FUNCTION	YES OR NO
>>POLLING RECEPTION	↑
SYSTEM SET	↓

2. Use the **▲** and **▼** keys to move the >> symbol.

If you press **▼** a few times, the remaining 2 functions are displayed.

If the function you want is not there, either:

Press **No**.

Press **▼** until the display changes to that shown opposite.

Then enter the function number as you would normally.

>>QUICK DIAL PROG./CHNG	↑
TRANSMISSION CLR/CHNG	↓

3. Press **Yes**.

QUICK DIAL	CHOOSE KEY
<input checked="" type="checkbox"/> []	PRINT LIST →
	NO TO CANCEL

GENERAL PRECAUTIONS

WARNING: Do not attempt any maintenance or troubleshooting other than that mentioned in this manual. This machine contains a laser beam generator and direct exposure to laser beams can cause permanent eye damage.

POWER AND GROUNDING

Pay attention to the following.

Power Supply

1. Power requirements: 115 V, 60 Hz
2. Insert the power plug securely into the wall socket.
3. Make sure that the wall outlet is near the machine and readily accessible.
4. Do not connect other equipment to the same socket.
5. Do not step on or set anything on the power cord.
6. Do not connect other equipment to the same extension cord.
7. Be sure that the power cord is not in a position where it would trip someone.
8. The wall outlet must be easily accessible.

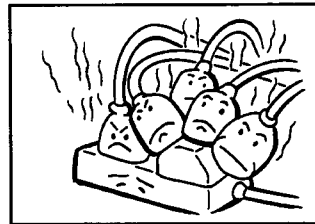
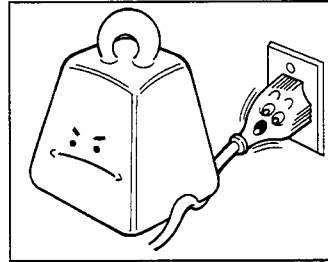
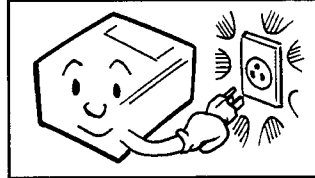

Grounding

Ground the machine and the lightning protection circuit in accordance with regulations. Do not ground to gas or water pipes, or to a telephone ground plug. Proper grounding is to the ground terminal of the power outlet. Be sure that the ground terminal of the power outlet is properly grounded.

The lightning protection circuit for the machine requires the machine to be properly grounded. If proper grounding is provided, about 90% of lightning damage can be prevented. For safety, be sure to connect the machine to a three-prong grounded outlet.

COLD WEATHER POWER-UP

Avoid raising the room temperature abruptly when it is below 57°F, or condensation may form inside the machine.

1. Raise the room temperature to 68°F at less than 18°F per hour.
2. Wait for 30 to 60 minutes.
3. Turn the power on.

Do not use the machine near a humidifier.

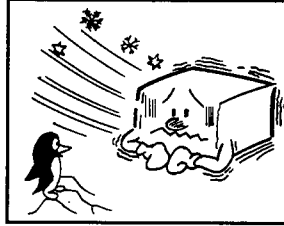

THUNDERSTORMS

With proper grounding, about 90% of lightning damage can be prevented. However, if possible, during severe electric storms turn the power switch off and disconnect the power cord and telephone line cord.

Note:

All fax messages stored in the memory may be erased if power is switched off for more than an hour.

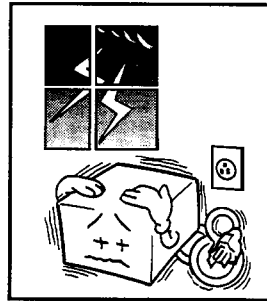

COPY PAPER

- 16 to 24 lb. copy paper is recommended: letter or legal sizes are the most commonly used
- Do not use damp paper, or copies will be defective.
- Do not touch copy paper if your fingers are wet or oily; fingerprints may appear on the copy.
- Keep paper in a vinyl bag if it will not be used for a long time.
- Store in a cool dry place.
- Store flat. Do not stand upright.
- The following materials cannot be used in the paper trays: Post cards, Tracing paper, OHP sheets, Adhesive labels
- Do not overload the paper trays.
- If multi-sheet feeding occurs or dog-eared copies are made when using recycled paper in the paper tray, fan the recycled paper and load it in the paper tray again.

TONER CARTRIDGES

- Store in a cool, dark place.
- Never store where they may be exposed to heat.
- Keep out of the reach of children.
- Do not eat toner.
- Do not lay heavy objects on toner cartridges.
- Do not incinerate toner or toner containers. Toner dust may cause flashback when exposed to an open flame.

OPERATING PRECAUTIONS

- While the machine is in operation, do not turn off the main switch or unplug the power cord.
- Keep corrosive liquids, such as acid, off the machine.
- Do not allow paper clips, staples, or other small metallic objects to fall inside the machine.
- The fusing unit may be very hot. Be careful when handling it.

GENERAL

- Read the Important Safety Information at the front of this manual.
- Since some parts of the machine are supplied with high voltage, make sure that you do not attempt any repairs or attempt to access any part of the machine except those described in this manual.
- Do not make modifications or replacements other than those mentioned in this manual.
- When not using the machine for a long period, disconnect the power cord.

OZONE

The machine generates ozone during operation. Normally, the ozone level is safe for operators. However, during a long copy run or while printing a long message, ozone odor may appear; in such a case, ventilate the room.

WARNING:



This symbol is intended to alert the user to the presence of important operating and maintenance (servicing) instructions in the literature accompanying the machine.



This symbol is attached to some components to alert the user not to touch them, because they may be very hot.

GUIDE TO COMPONENTS

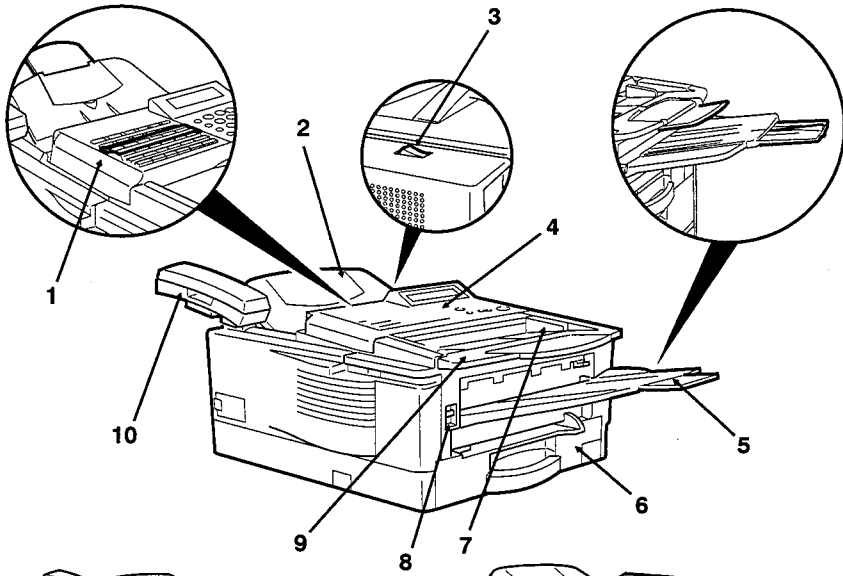

GUIDE TO COMPONENTS

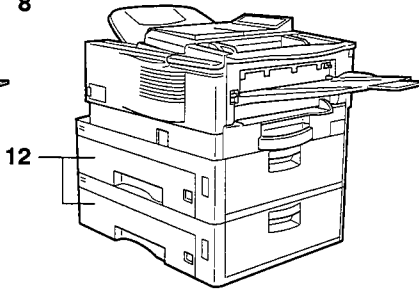
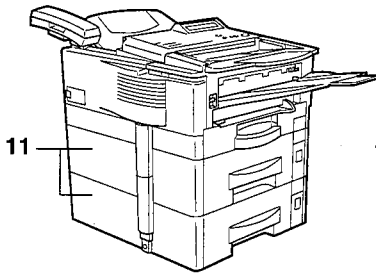

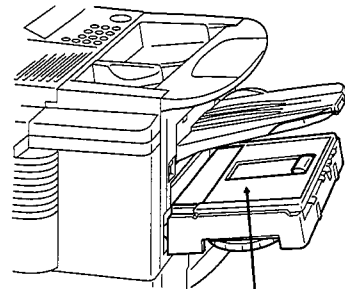

1	Quick Dial Key Flip Plate
2	Document Tray
3	Power Switch
4	Operation Panel
5	Copy Tray
6	Paper cassette
7	Document Guide
8	Front Cover Release Button
9	Document Table
10	Optional Telephone Handset
11	Optional Front Paper Feed Unit
12	Optional Side Paper Feed Unit
13	Optional Removable Cassette

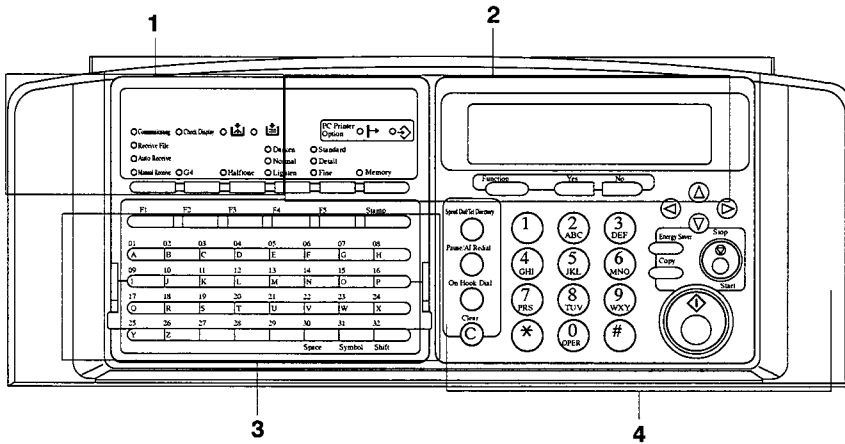

13

OPERATION PANEL



1.	Communicating Indicator	Lights when a fax message is being transmitted or received
	Receive File Indicator	Lights when an incoming message was received into memory. Blinks when confidential reception file or memory lock file is stored in the memory.
	Check Display Indicator	Lights when some error occurs. See the instruction appearing on the display.
	Add Toner Indicator 	Blinks when the toner cartridge is almost empty, and lights when it is empty.
	Add Paper Indicator 	Lights when a cassette is empty.
	PC Printer Option Indicators	These indicators are only used when the optional Printer Interface Kit is installed. See the operation manual for the Printer Interface Kit for full details.
	Reception Mode Selector Key	Press to select Auto Receive or Manual Receive.
	Contrast Selector Key	Press this to select either Darken, Normal or Lighten
	Resolution Selector Key	Press this to select either Standard, Detail, or Fine transmission mode.
	Halftone Key	Press this to use halftone transmission mode.
	G4 Selector Key/Indicator	Press to select the G4 mode. When this indicator is not lit, G3 is selected.
Memory Key	If the indicator is lit, your document will be stored before transmission. If it is not lit, your document will be sent immediately without being stored. Press the key to change the mode.	

2.	Display	Displays prompts, warnings, and selected modes.
	Function Key	Press to use one of the numbered functions explained in this manual.
	Yes/No Keys	Use to answer questions on the display.
3.	Scroll Key	When an arrow is shown on the display, use this key to access the options, items, or functions shown by the arrow. Also use it to move the cursor when programming or editing a displayed item.
	Quick Dial Keys	Each of these can be programmed with a telephone number, a group, or a keystroke program. You can also use these keys to type names and labels such as the RTI and TTI. To access keys 01 to 32, flip the number plate down. To access keys 33 to 64, flip the number plate up.
	User Function Keys	Each of these can be programmed for rapid access to frequently used features. If the light under a key is on, the feature can be used.
	Stamp Key	Press to enable or disable the transmission/scanning verification stamp feature.
4.	Speed Dial/Tel Directory Key	Press this to dial using Speed Dial or the Telephone Directory Feature.
	Pause/All Redial Key	Press this if you need to insert a pause when dialing. Or press this to redial one of the last ten numbers that were dialed.
	On Hook Dial Key	Press this to dial without picking up the handset.
	Clear Key	Use this as a backspace key during programming.
	Ten Key Pad	Use this as a telephone keypad, or to enter Speed Dial codes.
	Energy Saver Key	Hold this down a few seconds this to start or end the energy saver mode.
	Copy Key	Press this to copy the document now in the feeder.
	Stop Key	Press this to stop the machine and return it to standby mode.
	Start Key	Press this to start fax communication.

ROUTINE OPERATION

SENDING A FAX MESSAGE

Precautions Concerning Unacceptable Document Types

Before you send your document, make sure that it meets the following requirements.

Caution: Documents that do not meet these requirements can cause your machine to jam or may cause some components of the machine to become damaged or dirty.

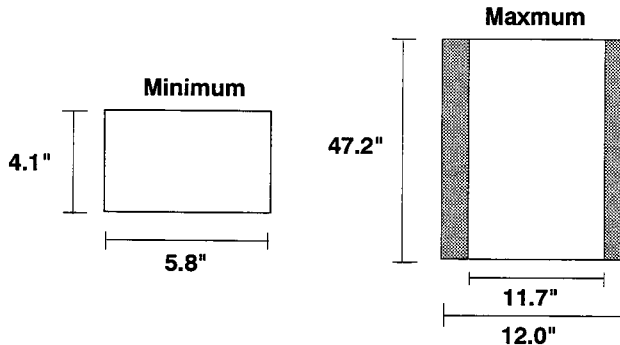

* The part shaded  will not be scanned, because it is outside the maximum scanning width range.

Correct Size for the Document Feeder

Thickness: 2 to 8 mils (20 lb paper)

Length and Width: See the above diagram.

If the page is too short, put it inside a document carrier or enlarge it with a copier.

If the page is too long, divide it into two or more sheets.

Clearly Written

Small faint characters may not be transmitted clearly.

Uniform Page Size

Do not use different sizes of document in the same transmission.

Dry Ink







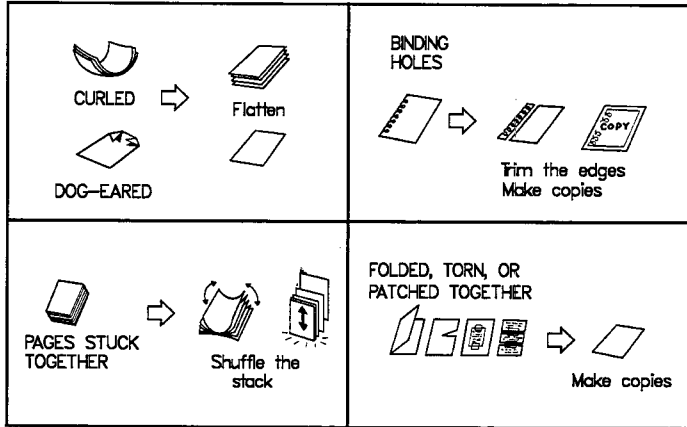

All ink must be dry before you place the document in the feeder.

Page Condition

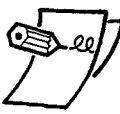
Do not place damaged pages in the automatic document feeder.

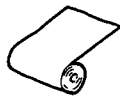

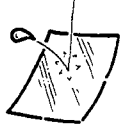
Originals that contain the following materials should not be placed in the document feeder. Make copies of these originals and scan the copies.

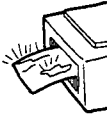
 <p>Crayon</p>	 <p>Paint</p>	 <p>Charcoal, Soft Pencil</p>	 <p>Glue, Adhesive Paper</p>	 <p>Thermal Paper</p>
 <p>Clips</p>	 <p>OHP Sheets, Vinyl Coated Paper</p>	 <p>Waxed Paper</p>	 <p>Carbon Paper</p>	 <p>Silicone Oil</p>

ROUTINE OPERATION

Note: Copies made with a copier that uses silicone oil may cause a misfeed. To avoid this, do not scan such copies until five or ten minutes after copying.

Transmission Procedure at a Glance

Overview

There are two ways to send a fax message.

- Immediate Transmission
- Memory Transmission

Immediate Transmission

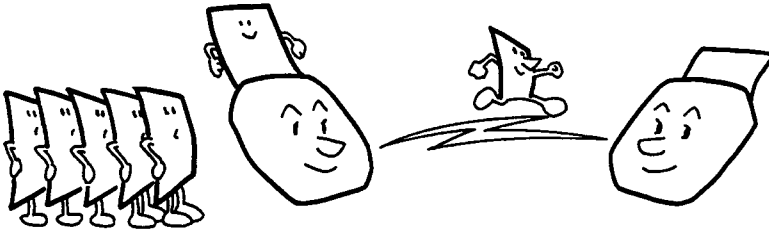

Immediate Transmission is convenient when:

- You wish to send a message immediately
- You quickly wish to check whether you have successfully connected with the other party
- Your machine's memory is getting full

The machine dials immediately after you press Start (or at the specified later time, if you used a time-delay feature like Send Later). The message is scanned and transmitted page by page without being stored in memory.

Memory Transmission

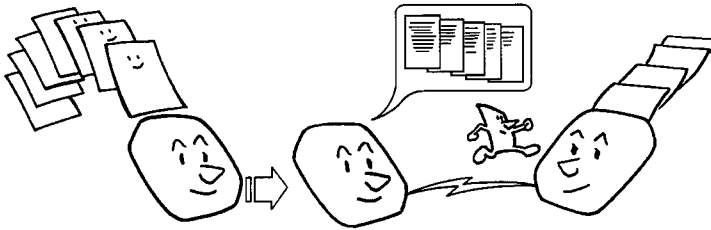

Memory Transmission is convenient because:

- Fax messages can be scanned much more quickly (you can take your document away from the fax machine without waiting too long).
- While your fax message is being sent, another user can operate the machine (people will not have to wait by the fax machine too long).
- You can send the same message to more than one place with the same operation.

After you press Start, the machine doesn't dial until all the pages of your fax message have been stored in the memory.

The default mode of this machine is Memory Transmission, so the procedures described in this manual will be based on the assumption that you are using Memory Transmission. Immediate Transmission is described in a separate section.

Cross-references

Send Later: see page 35.

Parallel Memory Transmission

With this feature the machine can call destinations while scanning documents. Compared with normal Memory Transmission where the machine calls once all the documents have been stored, it is quick to verify whether a connection has been made or not.

Additionally, as scanning finishes more quickly than Immediate Transmission, it is useful if you want to take the document back to your desk immediately. However, if the connection cannot be made (for example if the line is busy), normal Memory Transmission takes place.

NOTE: If the amount of available memory is less than 50%, you cannot use Parallel Memory Transmission.

Normal Memory Transmission still takes place when using the following:

- Send Later
- Transfer Request
- Store Double Sided
- Specify Multiple Destinations
- Specified Image Area

The file is erased if any of the following happen during transmission:

- The Stop key is pressed.
- A document becomes jammed.
- There is not enough memory available.

After a parallel Transmission fails, a communication result report is printed.

When using Parallel Transmission, page numbers are not printed at the other end. If you want page numbers printed, use Page Count of the optional feature for transmission. (See page 36.)

Sending to Just One Location

1. Make sure that the machine is in standby mode:

The display on the operation panel must be as shown on the right.

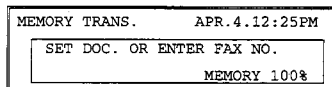

2. Carefully place your fax message face down into the auto document feeder.

Note: You can dial without placing the message in the feeder first. Place the document after you dial the number and go to step 4.

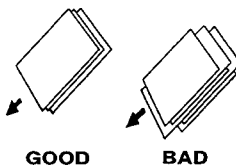
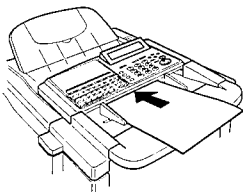
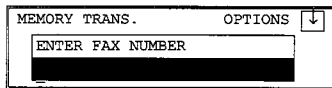

- The pages must be placed face down in the feeder, with the first page at the bottom of the stack.
- Feed the pages in so that the top edge goes in first.
- Do not exceed the feeder capacity:
Standard letter: Up to 50 pages at a time.
Double letter: Up to 25 pages at a time
- Do not use pages of different sizes.
- The pages should be arranged loosely, but the leading edges should be tidy, as shown above.

Selecting Contrast and Resolution: See page 30.

Options for Sending a Message: See page 34.

3. Dial in one of the following ways.

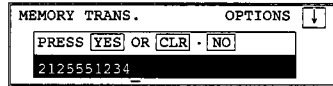

a) Ten Key Pad	b) Quick Dial	c) Speed Dial	d) Upgraded Speed Dial ☆1	d) Handset ☆2
	<p>Example: QuickDial 12</p>	<p>Example: SpeedDial 10</p>		

☆1 : Assuming user function key F1 is programmed as the Upgraded Speed Dial key. Optional Function Upgrade Card required.

☆2 : Only if the telephone handset is installed.

If your telephone line is through a PBX, dial the access code, then a pause, then the telephone number.
 For an international number, press the Pause key after entering the country code.

4. **Start**
5. The machine stores your fax message.
6. The machine dials, and the line to the other party is connected.

Note: Watch the display. The identification of the other party will appear.

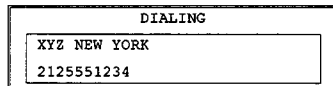

7. After sending the message, the machine hangs up automatically.

ROUTINE OPERATION

Sending to More Than One Location (Broadcasting)

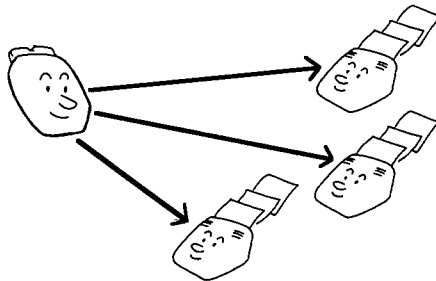

1. Make sure that the machine is in standby mode (see page 24).
2. Make sure that the Memory indicator is lit. If it is not, press **Memory**.
3. Place your fax message face down into the feeder.

- You can dial without placing the message in the feeder first. Place the document after you dial the number and go to step 5.

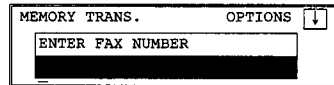

Selecting Contrast and Resolution: See page 30.

Options for Sending a Message: See page 34.

Scanning only a part of the document (Specified Image Area): See page 91.

4. Dial in one of the following ways.

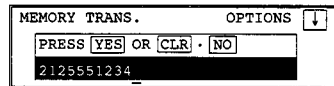

a) Ten Key Pad	b) Quick Dial	c) Speed Dial	d) Upgraded Speed Dial ★1	d) Group Dial ★2
	<p>Example: QuickDial 12</p>	<p>Example: SpeedDial 10</p>		<p>Example: Group 1, stored in Quick Dial Key 08</p> <p>Method 1: 08</p> <p>Method 2: F4 1</p>

- ★1: If the F1 of the user function key is programmed as the Upgraded Speed Dial key.
- ★2: Method 1: Press the Quick Dial Key the Group is stored in (in the example, press key 08).
 Method 2: If you do not know which Quick Dial Key the Group is stored in but you do know the Group number, use Method 2. You must have programmed one of the User Function keys in advance with code 02 (Group Dial), using Function 35 (see page 148). In the above example, F4 has been made the Group Dial key; press F4 then input the Group number.

If your machine is behind a PBX, dial the access code, then a pause, then the telephone number. For an international number, place a pause after the country code. To input a pause, press the Pause key.

5. **Yes.**

MEMORY TRANS.	OPTIONS ↓
ENTER FAX NUMBER	

6. Either:

- Dial another number: Go to step 4.
- Press **Start**.

The machine will dial the first destination (or, if you selected Send Later, it will return to standby mode and the fax message will be sent at the time that you selected).

NOTE: In theory, you can send the same fax message to up to 132 different destinations using the above procedure. However, this number depends on how many numbers are currently waiting in memory to be dialed. See the table on page 303 for more information concerning the limitations to this feature.

Check your Destinations Before Dialing

If you wish to send a fax message to more than one location, you can scroll through the list of telephone numbers that you have input so far to check whether you have missed any or entered any wrong numbers.

This feature is useful when using the features such as Broadcasting, Transfer Request, and Polling Reception.

Cross-reference
 Broadcasting: see page 26. Transfer Request: see page 58.
 Polling Reception: see page 140.

1. Press **▼ 0 7**.

- The number after DEST shows how many numbers you have input so far.

CHECK DEST.	PRESS YES OR NO
<input checked="" type="checkbox"/> 01 XYZ CO. NEW YORK	
DEST. : 2 ↓	

2. Use the **▼** arrow to scroll through the list of destinations that you have already input.

- To cancel a destination that you have input by mistake: **No**.
- To finish checking: **Yes**.

CHECK DEST.	PRESS YES OR NO
<input checked="" type="checkbox"/> ABC COMPANY	
DEST. : 2	

ROUTINE OPERATION

Storing Double Sided Documents

When you are using Memory Transmission and press the User Function Key programmed as Store Double Sided, both sides of a document can be scanned. The front and back of the scanned document will be printed in order, on separate sheets at the other end.

The procedure for transmission using Store Double Sided is outlined below. (Programming the User Function Key see page 148.)

1. Check the Memory indicator is lit.
2. Press the User Function Key (F1-F5) programmed as Store Double Sided.
3. Set the double sided document with the front page face down.
4. Select the resolution settings you require and dial then press **Start**. The front page will start to be scanned. When scanning has finished, "TURN OVER, RESET, PRESS START" will appear on the display.
5. Set the document with the reverse side face down and press **Start**. You have 60 seconds to set the reverse side - if you do not, an error will occur and you cannot transmit.

For how to deal with the case when the number of pages does not match (for example if you have accidentally fed several documents in at the same time), do as follows.

If the PAGE NO. INCORRECT CLEAR FILE? YES•NO appears in the display.

While storing a double sided document, the number of front pages does not match the number of reverse pages. Either:

- Press **Yes** to completely erase the stored document and return to standby mode.
- Press **No** to return to standby mode and begin transmission of the pages that have been stored so far.

Possible Problems

You want to take out the document

Open the scanner, and take out the document.

Caution: Do not pull out the document without opening the scanner, or you will damage the machine.

You want to send more than 50 pages

While the last page is being fed in, place more pages (up to 50) in the feeder.

You made a mistake while dialing

If you already pressed **Start**, press **Stop** immediately.

If you haven't pressed **Start** yet, either

- No**. The entire number is deleted. Enter a new number.
- Clear**. Only the last digit is deleted.

The Check Display Indicator is blinking

- If CLEAR ORIGINAL appears in the display:
Take out the document (see page 206). Then redial the destination.
- If ERROR PRESS STOP KEY appears in the display:
If the Communicating lamp is not lit, press **Stop**.
If the Communicating lamp is lit, wait until it goes out, then press **Stop**.

The buzzer is ringing

The other party wishes to speak with you. Proceed as shown below.

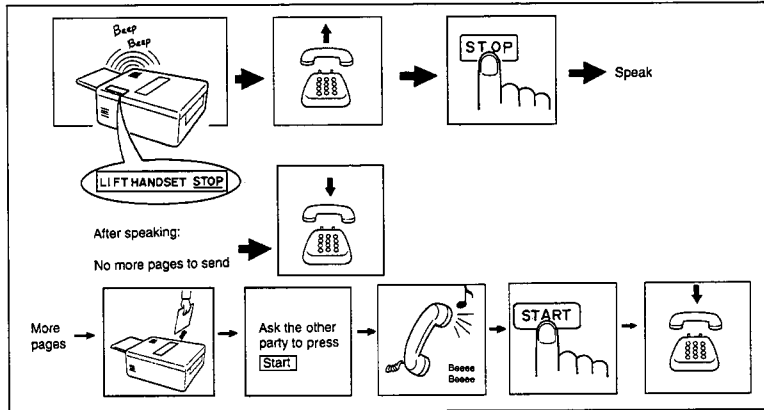

ROUTINE OPERATION

Contrast, Resolution, and Halftone Modes

You may wish to send many different types of fax message. Some of these may be difficult to reproduce at the other end. However, your machine has three settings that you can adjust to help you transmit your document with the best possible image quality.

If you are not sure whether your settings are suitable, make a copy of the document using these settings. The printout shows how the fax message will look when it is printed at the other end.

- If your fax message has more than one page, you can select different settings for each page. For example, if you wish to use a different resolution just for page 2, change the resolution setting while page 1 is being scanned. Then, while page 2 is being scanned, you can return the resolution setting to the original setting.

Contrast

The text and diagrams in your document must stand out clearly from the paper they are written on. If your document has a darker background than normal (for example, a newspaper clipping), or if the writing is faint, adjust the contrast.

There are three grades.

Normal: Suitable for most documents

Darken: Use for documents with faint writing (such as those written in pencil)

Lighten: Use for documents that have a dark or patchy background

Resolution

If your document contains fine print or detailed diagrams, use a higher resolution setting.

Standard: Suitable for most typewritten documents

Detail: Use for documents with small print or fine details

Fine: Use this for high quality reproduction

Halftone

If your document contains a photograph, or diagrams with complex shading patterns or grays, switch Halftone Mode on to achieve optimum image quality.

Selecting the Halftone Type

This model has two types of Halftone: the Dither Process and the higher quality Error Diffusion Process. To change the currently used Halftone type, perform the following procedure.

1. **Function 6 0 2 2 2 6 and 3.**
The settings for switch 00 are now shown on the bottom line of the display.

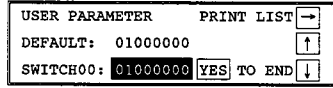

2. Press ▲ or ▼ until the settings for switch 10 are shown. You need to change digit 7.

If you wish change the setting press 7 on the ten key pad.

Digit 7

1: Speed mode

0: Standard mode

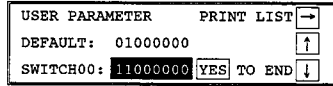

Speed mode: The machine will use the Basic Halftone Process.
Standard mode: The machine will use the higher quality Error Diffusion Process.

3. Finish: **Yes and Function**
Halftone Mode slows down the transmission speed, and may increase your communication costs, especially if you use the Error Diffusion process. Higher resolutions also do this. This is because these settings create larger amounts of data to be sent.

Messages are transmitted the fastest if you use the standard resolution setting, and keep Halftone off.

ROUTINE OPERATION

Home Position Setting Adjustments

For the contrast, resolution, and halftone, you can select whether the settings return to home position at the end of transmission (in a new machine, they do). Also, you can change the home positions of these settings.

If you need other adjustments, contact a service representative.

The procedure is as follows (see page 11 if you need more information about the User Parameter settings adjustment procedure).

1. **Function 6 0 2 2 2 2 6** and **3**.

USER PARAMETER	PRINT LIST →
DEFAULT: 01000000	↑
SWITCH00: 01000000 YES TO END	↓

At this time, you can print a User Parameter List if you press **▶** and **Start**.

2. The settings for switch 00 are now shown on the bottom line of the display.

SWITCH00: 0000 0000
Digit 7654 3210

The digits are numbered from 7 to 0; the setting of digit 7 is shown at the left side of the display and digit 0 is at the right.

The settings that you may need to change are those for digits 0, 1, 2, 3, 4, 5, 6, and 7. The functions of these are as follows.

Digit	Purpose							
0	Stamp		0: Off*	1: On				
1	Contrast home position							
	Digit 3	Digit 2	Digit 1	Setting	Digit 3	Digit 2	Digit 1	Setting
2	0	0	0	Normal*	1	X	X	Do not use
3	0	0	1	Lighten	this setting			
	0	1	0	Darken				
4	Resolution home position							
	Digit 5	Digit 4	Setting	Digit 5	Digit 4	Setting		
5	0	0	Standard*	1	0	Fine		
	0	1	Detail	1	1	Do not change these settings.		
6	Transmission mode home position							
	0: Memory transmission*			1: Immediate transmission				
7	Halftone on/off home position		0: Off*	1: On				

3. If you wish to change one of the settings, press the key on the ten key pad that corresponds to the digit that you wish to change.

Example: **3** from the ten key pad. The value of digit 3 changes.

4. Finish: **Yes** and **Function**.

Dialing with the Telephone Directory

This can be done for any number that you have stored as a Speed Dial Code with a label programmed for it.

Example: You wish to dial "XYZ CO. LONDON".

1. Make sure that the machine is in standby mode (see page 24).
2. Place your document in the feeder.

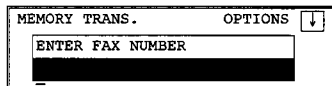

3. **Speed Dial/Tel Directory.**

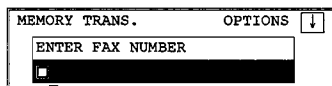

4. Press the first letter of the name: **X**
(Quick Dial Key **24** or **48**)
Press **X** repeatedly until the correct number is displayed.



5. **Yes.**

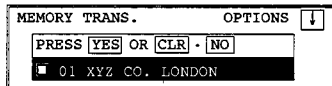

6. **Yes again.**

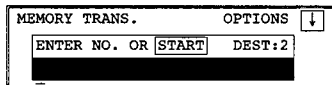

7. Either:
 - Dial more numbers.
 - Press **Start**.

 Programming Speed Dial Codes: See page 290.

ROUTINE OPERATION

Optional Features for Transmission

When you make a routine transmission, you can access a few optional features. These options are only available if " OPTION  " can be seen in the top right corner of the display.

Personal Code



Personal Codes do the following.

- They allow you to keep track of machine usage (for example, for billing purposes). If everybody uses a Personal Code when they use the fax machine, the codes, or the names programmed into the codes, will be printed on the report that is called the TCR (Transaction Confirmation Report). This will help you to check on who has been using the machine, and how often.
- They allow personalization of documents and printed reports. For example, if you use Label Insertion and store your name with your Personal Code, the receiver of your fax message will see your name at the top of the printout. This eliminates the need for a cover page.
- They allow you to restrict use of the machine to authorized personnel only. If you switch the Restricted Access feature on, users have to enter their personal code before they can use the machine. The personal code must have already been stored in the machine. This may deter unauthorized personnel from casually using the machine.

Cross-references

Programming Personal Codes: see page 82.

Label Insertion: see page 93.

Restricted Access: see page 82.

TCR: see page 176

If you input your Personal Code, your name will appear on the TCR and Transmission Result Report.

1. Press **▼ 0 1**.

PERSONAL CODE	ENTER CODE
██████████	
	<input type="button" value="NO"/> TO END

2. Enter the personal code
Example: **7 3 6 2**

- The display shows the name that was stored with the code that you selected. In this example, it is SMITH.

PERSONAL CODE	PRESS <input type="button" value="YES"/> OR <input type="button" value="NO"/>
7362	SMITH

3. **Yes.**
See page 82 for details on how to program the Personal Codes and their labels.

Send Later

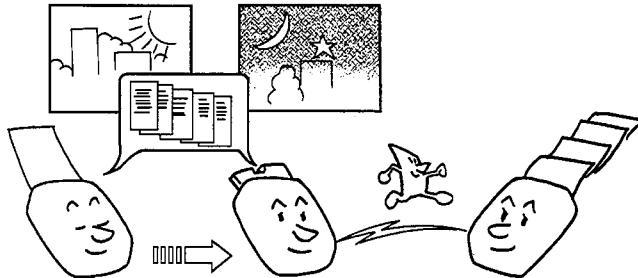

ROUTINE OPERATION

Using this feature, you can instruct the machine to delay transmission of your fax message until a later time, which you specify. This allows you to take advantage of off-peak telephone line charges without having to be by the machine at the time.

CAUTION: If your machine's memory is full, you will have to keep the message in the document feeder. This means that nobody can use the document feeder unless they remove your document. This would automatically cancel the Send Later operation.

1. Press **▼, 0** and **2**.

SEND LATER	ENTER START TIME
██████████	AM/PM: #
NOW 12:15 PM	<input type="button" value="NO"/> TO END

2. Example: Send at 11:30pm
1 1 3 0 from the ten key pad.
 To change AM/PM, press * or # on the ten key pad.
3. **Yes.**
 The Send Later time cannot be more than 24 hours into the future.

SEND LATER	PRESS	YES	OR	NO
TODAY	11:30	PM	AM/PM:	#

MEMORY TRANS.	OPTIONS	↓
ENTER FAX NUMBER		
[REDACTED]		

Page Count (Immediate Transmission only)

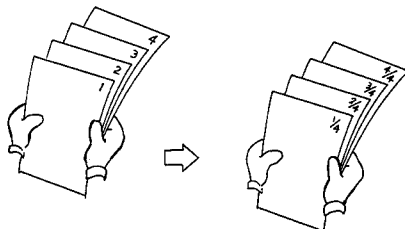

When your fax message is printed at the other end, page numbers will be printed on the top of each page. Using the Page Count feature, you can select the format in which the page numbers are printed.

If you use Page Count:

- Page numbers will be printed in batch-numbering format (for example, p1/3, p2/3, and p3/3 for a three-page message). This makes it easy for the other party to see how many pages you sent, and if any are missing. However, you have to input the number of pages at the keypad before sending.

If you do not use Page Count:

- Page numbers will be printed only as a sequence (for example, p1, p2, p3). This makes it difficult for the other party to tell at a glance whether any pages are missing (for example, due to a double feed in your machine's document feeder).

Note: If you do not select Immediate Transmission, Page Count is automatically switched on, and the pages are counted automatically.

1. Press **▼**, **0** and **3**.

PAGE COUNT	SET COUNT
<input type="text"/>	PAGE(S)
	<input type="button" value="NO"/> TO END

2. Example: 10 pages.
1 0

PAGE COUNT	PRESS <input type="button" value="YES"/> OR <input type="button" value="NO"/>
<input type="text" value="10"/>	PAGE(S)

3. **Yes**.

TTI (Transmit Terminal Identification)

Normally, the TTI programmed in your machine is printed at the top of each of the pages you transmit when they are received at the other end. The top of the image will be overprinted if there is no margin at the top of the transmitted page.

In some cases, you may wish the other party to receive an unmarked copy of your original. In this case, you can switch TTI off.

Note: If you switch TTI off, make sure that Label Insertion is also off if you want the image received at the other end to be unmarked.

Cross-reference

TTI: see page 261.

Label Insertion: see page 93.

1. Press **▼**, **0** and **6**.

TTI	SELECT	<input type="button" value="←"/>	<input type="button" value="→"/>	<input type="button" value="YES"/> TO END
		<input type="button" value="ON"/>	<input type="button" value="OFF"/>	

2. If you wish to change the TTI setting, press **◀** or **▶** until the displayed setting is correct.

TTI	SELECT	<input type="button" value="←"/>	<input type="button" value="→"/>	<input type="button" value="YES"/> TO END
		<input type="button" value="ON"/>	<input type="button" value="OFF"/>	

3. **Yes** when you have finished.

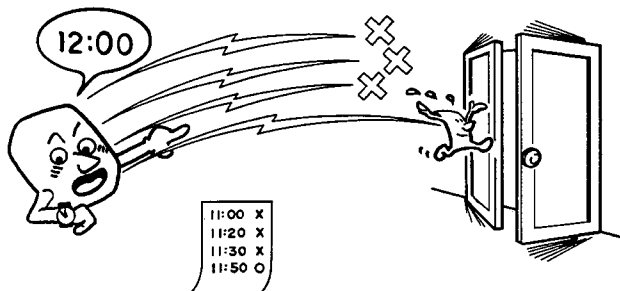
Transmission Deadline (TRD) (Optional Memory Card or Hard Disk is required)

If your message has to be sent to the other end before a certain time, use the Transmission Deadline option and input this deadline.

If the line is busy, the machine will redial at set intervals either until the message gets through or until the deadline passes. Before the deadline passes, there is no limit to the number of times that the machine can redial.

After the deadline passes, the machine will print a report which indicates whether or not your message was sent within the deadline. Then, the message will be erased from memory.

This feature is only available with Memory Transmission.

1. Press **▼**, **0** and **8**.

TRD	ENTER TRD TIME		AM/PM: #
	:		
NOW	12:15 PM	<input type="checkbox"/> NO	TO END

2. Example: The deadline is 12:50 pm.
1 2 5 0

TRD	PRESS <input type="checkbox"/> YES OR <input type="checkbox"/> NO		
TODAY	12:50 PM	AM/PM: #	

- The TRD time cannot be more than 24 hours into the future.
 - To change AM to PM or the other way around, press #.
3. **Yes.**

MEMORY TRANS.	OPTIONS <input type="button" value="↓"/>
ENTER FAX NUMBER	
[REDACTED]	

Economy Transmission (Optional Memory Card or Hard Disk Required)

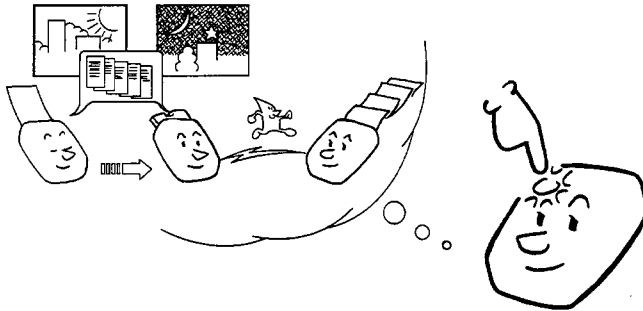

This feature is similar to Send Later. However, it has the added bonus of automatically combining two cost-saving features: use of off-peak rates, and Batch Transmission. Also, you do not have to input the required transmission time every time, like you do with Send Later. However, with Send Later, you can input a different time of transmission for each fax message.

If you select Economy Transmission, your fax message will be sent at the time that you previously stored for this feature using Function 72 (see the next page). Also, all messages that were stored for sending to the same destination using this feature will be batched automatically.

ROUTINE OPERATION

Cross-reference

Send Later: see page 35.

Batch Transmission: see page 97.

On/Off Selection Switch

When OPT is displayed.

1. Press **▼**, **0** and **9**.

-  If you have previously programmed this feature as a User Function Key, press that key.

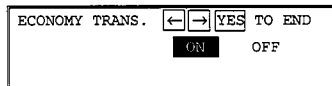

2. If you wish to change the **ECONOMY TRANS.** setting, press **◀** or **▶** until the displayed setting is correct.

3. **Yes** when you have finished.

Storing the Economy Transmission Time

Before using Economy Transmission, you must use Function 72 to program a time for Economy Transmissions to start. This should be the start of the off-peak rate period for your area. After you have stored this, you will not need to change it again until your telephone company changes the starting time of the off-peak rate period.

1. **Function 6 0 2 2 2 2 7** and **2**.

ECONOMY TX	
TIME=	11 :00AM
<input type="button" value="←"/>	<input type="button" value="→"/>
<input type="button" value="YES"/>	TO END

2. Input the time that you always wish Economy Transmissions to start.
 To change from AM to PM and vice versa, press * or #.
3. Press **Yes Function** when the display is correct.

Immediate Transmission

Procedure

If you do not wish to store the fax message in memory before sending it out, use the following procedure.

- The advantages and drawbacks of Immediate Transmission and Memory Transmission are discussed on pages 22 and 23.

1. Make sure that the machine is in standby mode (see page 24).
2. Make sure that the Memory indicators should go out. If it is lit, press **Memory**.
3. Place the document face down into the feeder.

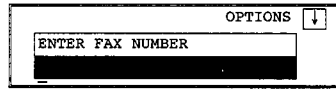

4. Dial (only one destination). And press **Yes**. See page 25 for how to dial.

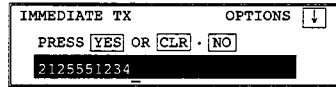

5. **Start**.

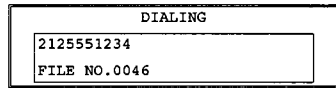

6. The machine dials and the line to the other party is connected. The number that you dialed is displayed (or if you used Quick Dial or Speed Dial, the Quick Dial or Speed Dial Label stored for that number is displayed).

Converting Immediate Transmission to Memory Transmission

If there is a message still waiting in the document feeder, you can convert it into a memory file if you press **Memory** and **Start** and **Yes**. The document will be scanned and stored into memory, leaving the document feeder free for others to use.

ROUTINE OPERATION

Transmission Mode Home Position Adjustment

The default mode of your machine is Memory Transmission. If you wish, you can change this home position to Immediate Transmission.

The procedure is as follows (see page 7 if you need more information about the User Parameter settings adjustment procedure).

1. **Function 6 0 2 2 2 6** and **3**.

- At this time, you can print a User Parameter List if you press **▶** and **Start**.

USER PARAMETER	PRINT LIST	→
DEFAULT:	01000000	↑
SWITCH00:	<u>01000000</u>	YES TO END ↓

The settings for switch 00 are now shown on the bottom line of the display. The setting that you need to change is that for digit 6.

2. If you wish to change the setting, press **6** on the ten key pad.

SWITCH00: 0000 0000

Digit 6 (Double underlined)
0: Memory Transmission
1: Immediate Transmission

3. Finish: **Yes** and **Function**.

Using the Stamp

Press the Stamp key to achieve the transmission verification stamp. When the Stamp indicator is lit, the machine stamps a small mark on the bottom of each page. During memory transmission, the stamp indicates that the page was successfully stored. For immediate transmission, it shows that the page was sent successfully. You must switch the stamp on before you press **Start**, or the machine will not stamp the first page.

- If you wish the stamp to be at the top of each page instead of at the bottom, contact your service representative.

Changing the Stamp Home Position Setting

If you wish to change the Stamp default setting, do the following.

(See page 11 if you need more information about the User Parameter settings adjustment procedure).

1. **Function 6 0 2 2 2 6 and 3.**
At this time, you can print a User Parameter List if you press **▶** and **Start**.

USER PARAMETER	PRINT LIST	→
DEFAULT:	01000000	↑
SWITCH00:	<u>01000000</u>	YES TO END ↓

The settings for switch 00 are now shown on the bottom line of the display. The setting that you need to change is that for digit 0.

SWITCH00: 0000 0000
Digit 0 (Double Underlined)
0: Verification stamp off
1: Verification stamp on

2. If you wish to change the setting, press **0** on the ten key pad.
3. Finish: **Yes** and **Function**.

Redialing

If a message was not transmitted successfully, that does not mean that you have to enter the telephone number again. In many cases, the machine will redial the destination automatically. Or, with the AI Redial key, you can redial with just a few keystrokes.

Automatic Redialing

The machine will automatically redial the other party if any of the following conditions occurred.

- The other party was busy
- There was no reply from the other party
- The message was rejected by the machine at the other end because of excessive errors (in this case, redialing will only take place if Memory Transmission was used)

Redialing is done 4 times at 5 minute intervals (for a memory transmission) or 2 times at 5 minute intervals (for an immediate transmission).

- The number of redials and the redial interval may be adjusted by a service technician.

During redialing, the number being dialed is displayed as shown on the right.

[2125551234]
MEMORY TRANS.	APR.4.12:25PM
SET DOCUMENT	
	MEMORY 99%

If redialing fails for an immediate transmission, the display appears as shown opposite. You can convert this communication to a memory transmission to free up the machine for other users. Press **Memory** then **Start**.

REDIAL STANDBY
OR SELECT MEMORY MODE
(PRESS MEMORY + START)

Using the AI (Artificial Intelligence) Redial Key

The machine learns and remembers the last 10 telephone numbers that you input. Then, if you have to redial one of these numbers, just press the AI Redial key until the number or name of the party you wish to redial is displayed, then press the Start key.

This feature has the following uses.

- If the machine is waiting to redial the other party, you do not have to wait for the redialing interval to expire. Press the AI Redial key until the required telephone number or name is displayed, then press the Start key.
- If you wish to send another message to the same address that you just sent one to recently, you don't have to dial the full number again if it is still in the AI Redial memory. Place the message in the feeder, then press the AI Redial key until the required telephone number or name is displayed, then press the Start key.

Notes:

- AI Redial only remembers one Quick Dial or Speed Dial number --- the last number dialed. When you dial another Quick Dial or Speed Dial, the previously dialed Quick Dial/ Speed Dial cannot be accessed.
- Using AI Redial, you cannot retry a failed Memory Transmission. However, you can redial the telephone number, as explained above.
- AI Redial employs the AI Short Protocol feature.
- The AI Redial key does not work if you used the handset to dial.

Cross-reference	AI Short Protocol: see page 171.
------------------------	----------------------------------

ROUTINE OPERATION

To send a fax using AI Redial, do the following:

1. Make sure that the machine is in standby mode (see page 24).
2. Place your document into the feeder.
3. **AI Redial.**

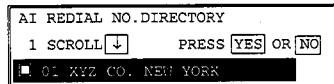

4. Scroll through the numbers in the AI Redial memory using the ▲ and ▼ arrows of the scroll key.

- To select a number: **Yes x 2.**

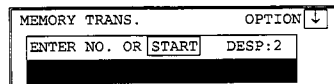

5. Either:
 - Select another number: go to step 4.
 - Start the transmission: **Start.**

RECEIVING FAX MESSAGES

Selecting the Reception Mode

There are two ways to set up your machine to receive fax messages.

- Auto Receive Mode
- Manual Receive Mode

Press the reception mode key to switch between the modes.

Auto Receive Mode

This mode is selected when the Auto Receive indicator is lit.

Incoming faxes are received automatically. You do not have to be by the machine if the power switch is kept on. Use this mode when you must leave the machine.

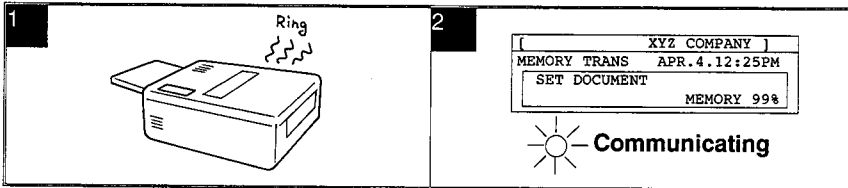

1. The telephone rings once.
2. The machine automatically starts to receive the message.

Manual Receive Mode

This mode is selected when the Manual Receive indicator is lit.

This setting is convenient if you wish to use your fax machine's handset to answer telephone calls coming in on the same line as fax messages. However, your fax machine cannot automatically receive fax messages; you have to be by the machine if a fax message comes in.

The machine operates as follows.

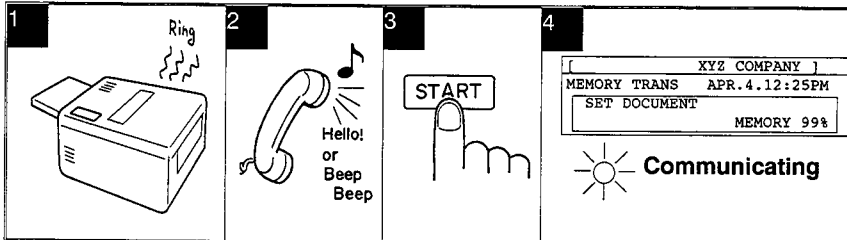

1. The machine rings continuously until you answer the call. Pick up the handset.
2. If you hear a voice from the other end, speak in reply.
If you hear a tone every few seconds, the other end is a fax terminal.
Note: Remove any documents that are in the feeder.
3. If the person at the other end wishes to send you a fax message, press **Start** to receive the message. Then hang up the handset.
4. The machine starts to receive the message.
The Communicating indicator lights.

Substitute Reception

Overview

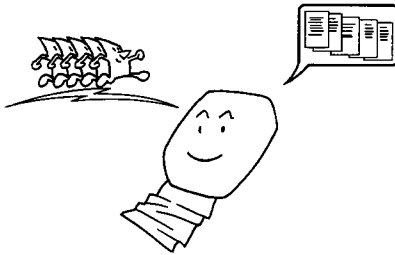

If the printer is jammed or out of supplies, you will still be able to receive fax messages; any messages coming in will be stored in the machine's memory. If the "Receive File" indicator is lit, a message has been stored in the memory using the Substitute Reception feature.

Check the following:

- The printer paper may be used up. If so, add paper: see page 181.
- The toner may have run out. If so, add toner: see page 187.
- The printer paper may have jammed. If so, remove the jam: see page 208.
- If there appears to be no problem, somebody may be making copies while a fax message is coming in.

The messages received into memory will be printed and erased from memory after the machine has been returned to normal operation.

Switching Substitute Reception On or Off

There are two conditions under which you may wish to disable this feature.

- If you do not like keeping received fax messages in memory: After your machine has received a fax message to memory, it sends an OK signal to the other end. However, if something happens to your machine and you lose the fax message before you have a chance to read it, the sender will not be informed. Therefore, you may not wish to use the Substitute Reception feature.
- If you do not wish to have your memory full of mail from unknown senders: If you have not enabled the Authorized Reception feature, you can receive fax messages from anybody. However, you can see who they are because their identifier (the TTI) is printed at the top of each page. If the other party has not programmed their identifiers (perhaps in an attempt to hide their identity), you may not wish to receive their messages into memory, which would take up valuable space.

Cross-reference
 ECM: see page 96. Authorized Reception: see page 109.

If you wish to switch Substitute Reception on or off, do the following procedure. (See page 11 if you need more information about the User Parameter settings adjustment procedure).

1. **Function 6 0 2 2 2 2 6** and **3**.
 At this time, you can print a User Parameter List if you press **▶** and **Start**.

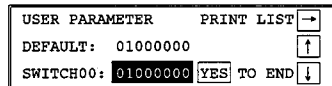

The settings for switch 00 are now shown on the bottom line of the display.

2. Press **▲** or **▼** until the settings for switch 05 are shown.
 The settings that you need to change are those for digits 0 and 1.
 The meanings of these settings are as follows.

SWITCH05: 0000 000
 Digit 0 (Underlined)
 Digit 1 (Double Underlined)

Digit	Purpose
0	Substitute Reception 0: Off 1: On*
1	Reception to memory (including Substitute Reception, Memory Lock, Forwarding, and Transfer Requests from another station) when no RTI or CSI identifiers were received from the other party 0: Enabled, 1: Disabled

3. If you wish to change the setting, press **0** or **1** of the ten key pad.
4. Finish: **Yes** and **Function**.

TELEPHONE CALLS

A handset is required to execute the procedures in this section.

You can use your fax machine for dialing in the same way as you would use a telephone. This is useful when calling fax machines that are usually kept in Manual Receive Mode, as well as for telephone conversations.

- You can dial using Quick Dial Keys or Speed Dial Codes.
- With the On Hook Dial feature, you do not have to pick up the handset before dialing.
- You can send a fax message after finishing the conversation, without having to make a new call.

Cross-reference Manual Receive Mode: see page 46.

Making a Telephone Call

Using On Hook Dial

Using On Hook Dial is like using the handset (see the next page), except that you do not have to pick it up before dialing. Just press the On Hook Dial key, and dial the number. When you hear the other party on the fax machine's built-in speaker, you can pick up the handset. This keeps both hands free for referring to telephone numbers while you are dialing.

1. Press the **On Hook Dial** key.

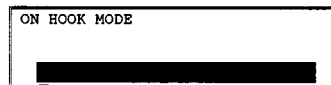

2. Dial.
 - ?** See page 25 for how to dial.
 - Do not use the handset.

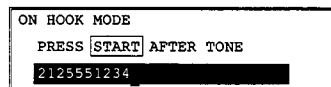

Note:

Do not press **Start**.

If you wish to cancel the call, press the **On Hook Dial** key.

3. Listen to your machine's built-in speaker. When the other party answers, pick up the handset.
4. Replace the handset when you have finished.

Using the Handset

Using the fax machine's built-in or optional handset, you can use the fax machine in the same way as a normal telephone. Pick up the handset and dial on the fax machine's ten-key pad (or use a Quick Dial Key or Speed Dial Code if you wish).

1. Pick up the handset.

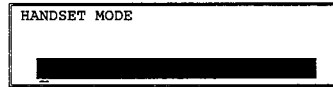

2. **Dial.**

? See page 25 for how to dial.

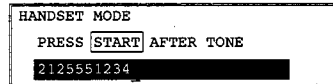

Note: Do not press **Start**.

3. Continue as for a normal telephone conversation.

Using AI Redial

Use AI Redial if you wish to redial a number that you dialed recently.

1. **On Hook Dial** and **AI Redial**.

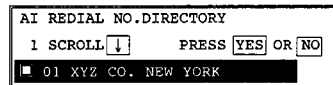

2. Scroll through the numbers in the AI Redial memory using the ▲ and ▼ arrows of the scroll key. When the correct number is displayed, press **Yes**.

The number will be dialed immediately.

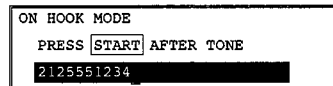

Answering the Telephone

If the telephone rings just once:

A fax is coming in. Do not pick up the handset.

If the telephone rings continuously:

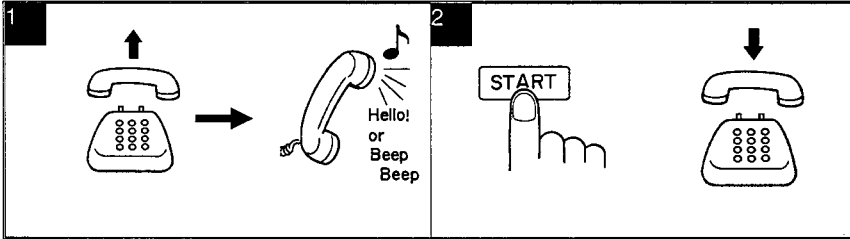

1. Pick up the handset and speak to the other party.
If you hear a high-pitched tone, a fax is coming in.
Press **Start** then hang up.
2. If the caller wants to send you a fax, press **Start** after speaking. Then hang up.

If nothing happens after you press Start the power may be switched off or the telephone may not be properly connected.

ROUTINE
OPERATION

Phoning and Faxing on the Same Call

To Talk Before Sending a Fax (On Hook Dial)

1. Press the **On Hook Dial** key.
2. Dial.
Note:
Do not use the handset.
Do not press **Start**.
3. If you hear a voice from the machine's built-in speaker, pick up the handset and speak to the other party.
 If you hear a high-pitched tone instead of a voice, place your fax message in the feeder, then press **Start**.
4. When you are ready to send your fax message, place your message in the feeder, then ask the other party to press **Start**.
5. When you hear a high-pitched tone, press **Start**.
6. Replace the handset.

Do not replace the handset if you wish to speak to the other party again.
When your machine emits a tone, press Stop then speak.

Speaker and Buzzer Volume Adjustments

Your machine has a built in speaker. With this speaker, you can listen to the telephone line without picking up the handset. The speaker will be automatically switched off just before the start of facsimile data communication.

When you are sending a fax message, you will be able to hear the line after the machine has dialed. If the line is busy, you can press the Stop key and start another operation without having to wait for the machine to disconnect the line.

The volumes you can adjust are;

Transmitting monitor (TRANSMISSION): Sound you hear in transmission.

Receiving monitor (RECEPTION): Sound you hear in reception.

Dialing monitor (DIALING): Sound you hear after pressing Start key.

Buzzer tone (ALARM): Volume of the buzzer when you open a cover and so on.

Key tone (SCROLL KEY): Sound you hear when you press a key on the operation panel.

If the speaker volume is not satisfactory, you can adjust it.

1. **Function 6 0 2 2 2 9** and **2**.

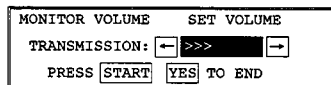

2. To increase: **▶**.
To decrease: **◀**.
To accept: **Yes**.

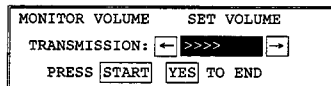

3. Repeat step 2 for each adjustment that appears on the screen.
4. Finish: **Function**.