

Owner's manual

Color Television RD0945/RD0946

Operating Instructions
Warranty Information

1

Return Your Owner's Registration Card Within 10 Days.

Registering your purchase is an essential step to guarantee you'll receive all of the benefits you're entitled to as a MAGNAVOX product owner. Complete and mail your Owner's Registration Card today to ensure your right to warranty verification, owner confirmation, model registration, plus a wide variety of special services and savings.



2

Know These Safety Symbols.

▲ This "bolt of lightning" indicates uninsulated material within your unit which may cause an electrical shock. For the safety of everyone in your household, please do not remove product covering.

▲ The "exclamation point" calls attention to features for which you should read the enclosed literature closely to prevent operating and maintenance problems.



3

Read Operating Instructions Carefully.

The information in this manual can help you take full advantage of your product's many features, and ensure years of safe, reliable operation. So don't miss out. Read the enclosed instructions, safety tips and warranty information today.

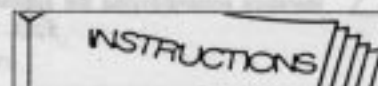

Table of Contents

Location Of TV Controls	3
Antenna Connections	4
AC Power	5
External Power Input Terminal	5
Remote Control Unit	6
When Turned On For The First Time	7
Operating Procedure	7
Setting The Clock	8
Setting The Timers	8
Programming Channels	9
Cable TV Operation	10
Sleep Timer Operation	10
Remote Control Battery Requirements	10
Audio/Video Input Jack Operation	11
External Speaker Jack Operation	11
Earphone Jack Operation	11
How to Adjust For The Best Picture	12
Before Calling For Service	13

Features

22 Pushbutton Infrared Remote Control which operates your TV set.

VHF/UHF/155 channel tuner for receiving standard broadcast or cable TV channels.

Programming channels for quick and easy selection of favorite stations available in your area.

On-screen graphics which display helpful information in the operation and adjustment of feature control settings such as channel, programming, timer settings picture, etc.

Every Day Timer enables you to select and watch a specific channel at the preset time everyday.

One Time Timer enables you to select and watch a specific channel at the preset time in a day.

Sleep Timer which automatically turns the TV OFF at preset times.

Please read all the information in this manual to fully understand the features of your set and ensure years of safe, reliable operation. Besides explaining the operation of your set, this manual also contains important warranty, safety, and service tips information.

Please attach your sales receipt to this book and keep it for future reference.

Model No. _____

Serial No. _____

Purchase Date _____

WARNING: TO REDUCE THE RISK OF FIRE OR ELECTRIC SHOCK, DO NOT EXPOSE THIS APPLIANCE TO RAIN OR MOISTURE.

CAUTION : TO PREVENT ELECTRIC SHOCK, DO NOT USE THIS (POLARIZED) PLUG WITH AN EXTENSION CORD, RECEPTACLE OR OTHER OUTLET UNLESS THE BLADES CAN BE FULLY INSERTED TO PREVENT BLADE EXPOSURE.



CAUTION
RISK OF ELECTRIC SHOCK
DO NOT OPEN



CAUTION: TO REDUCE THE RISK OF ELECTRIC SHOCK, DO NOT REMOVE COVER (OR BACK). NO USER-SERVICEABLE PARTS INSIDE. REFER SERVICING TO QUALIFIED SERVICE PERSONNEL.



The exclamation point within an equilateral triangle is intended to alert the user to the presence of important operating and maintenance (servicing) instructions in the literature accompanying the appliance.



The lightning flash with arrowhead symbol, within an equilateral triangle, is intended to alert the user to the presence of uninsulated "dangerous voltage" within the product's enclosure that may be of sufficient magnitude to constitute a risk of electric shock to persons.

Location Of TV Controls

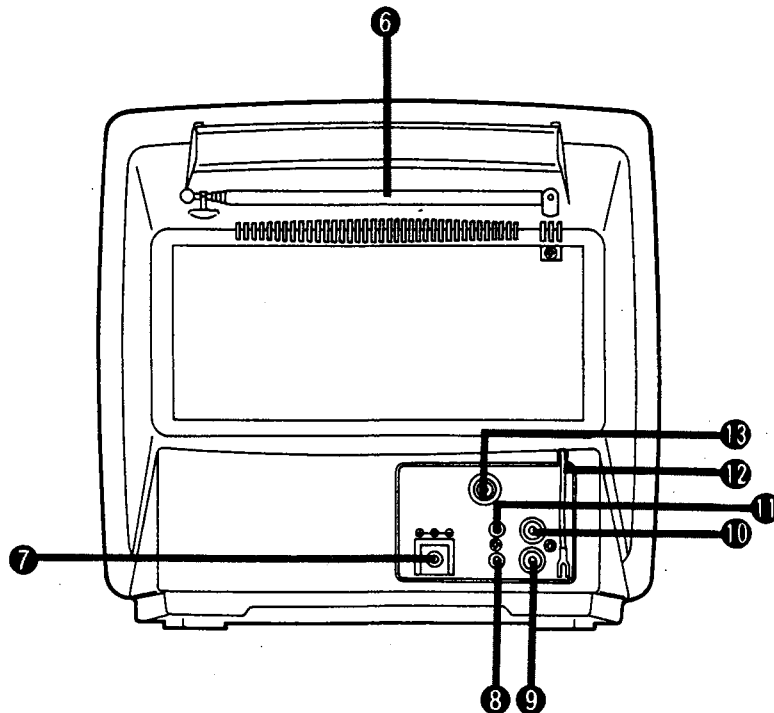
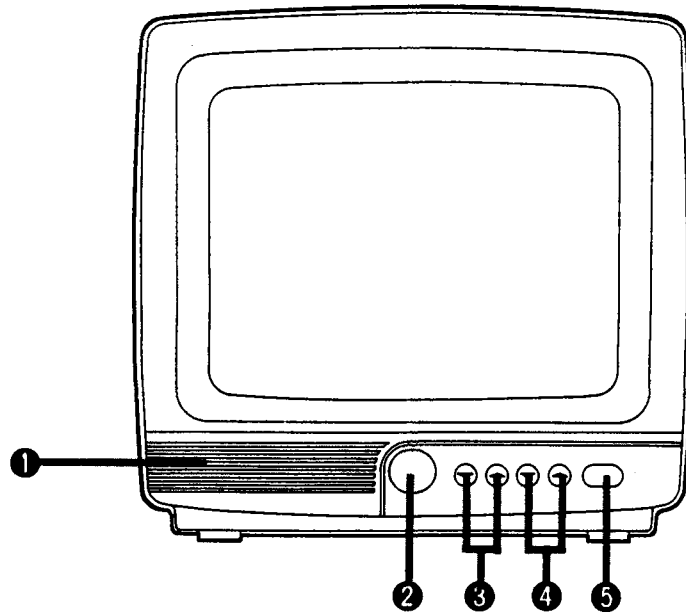

- | | | | |
|-------------------------|----------------------|---------------------|----------------------|
| ① Front Speaker | ⑤ Power Switch | ⑨ Audio Input Jack | ⑬ EXT. ANT. Terminal |
| ② Remote Control Sensor | ⑥ Telescopic Antenna | ⑩ Video Input Jack | |
| ③ Volume Buttons | ⑦ DC Input Jack | ⑪ EXT. Speaker Jack | |
| ④ Channel Buttons | ⑧ Earphone Jack | ⑫ Rod ANT. Wire | |

Antenna Connections

Built-in Antenna

Be sure that Rod ANT. Wire is connected to EXT. ANT. terminal using 300-75 ohm adapter.

Extend the telescopic antenna and adjust its direction, length and angle for best reception.

Outdoor Antenna

If reception from the built-in rod antenna is unsatisfactory, you can use the antenna terminal on the back of the TV to connect an external antenna.

Before you make one of the connections as described below, fold the telescopic antenna into place.

UHF/VHF Connector

The single 75 ohm connector for UHF/VHF provides an easy and quick connection of your antenna or cable system. The following examples describe the different ways for connecting various antenna systems.

Antenna Lead-In

There are two possible types of wires coming in from your antenna or cable system, either 300 ohm twin lead cable or 75 ohm coaxial cable.

1. If your antenna has a twin lead cable, you must use an adapter (supplied) like the one shown in the illustration. First attach the antenna wires to the screws on the adapter; then push the end of the adapter onto the terminal on the back of the TV.

2. If your system uses coaxial cable, connect it directly onto the terminal on your TV.

Connecting Rod Ant.

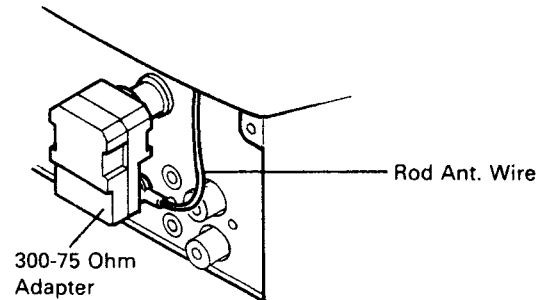

Outdoor Combination Antennas

1

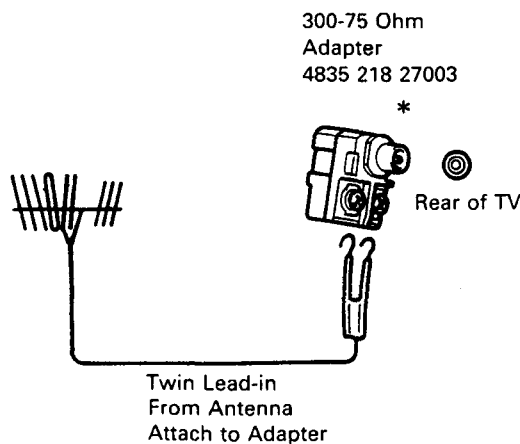

2

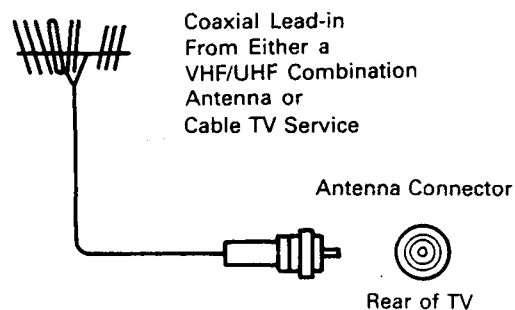

*Connect only one antenna twin lead-in to this adapter.

To order any optional accessories contact your dealer or call the toll-free accessory ordering number (1-800-292-6066).

AC Power

Your TV operates on 120 volts, 60 Hz (normal household current) and has a polarized plug. If you are unable to insert the plug fully into the outlet, try reversing the plug. Do not defeat the safety feature of this polarized plug.

External Power Input Terminal

A DC car adapter cord is included with your TV. This cord can be connected to the DC 12 V input terminal on the back of the set. The other end of the cord can plug into the cigarette lighter socket of your car, as illustrated. The TV will operate using this DC power source, in the same manner as AC power.

IMPORTANT: The polarity of the DC 12V input terminal is of a nonconventional nature. Attaching a DC power cord of reverse polarity will cause the 4 amp fuse to blow. Therefore, use the DC car adapter cord included with your TV.

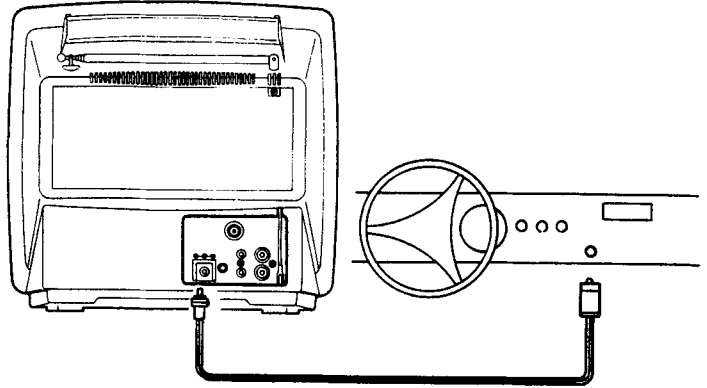

DC Car Cord 4835 015 57025

NOTES FOR CAR USE

1. While the car is moving, it may be difficult to obtain good reception due to signal variations.
2. Under the following conditions it is recommended to operate the TV with the engine idling.
 - a) Very low outside temperatures may cause difficult engine starts.
 - b) Viewing the receiver for more than just a few hours. (For personal safety when in a vehicle with engine idling always keep a window slightly open to prevent from possibly being overcome by engine fume leaks.)
3. Do not operate the set when starting the engine to avoid overloading the engine.
4. When finished viewing, turn off POWER and disconnect DC car cord from cigarette lighter. Failure to do so may discharge your car battery.
5. Always keep the cigarette lighter socket of the car clean. If the socket is dirty with cigarette ash, the resulting bad contact may overheat the car cord plug.

Remote Control Unit

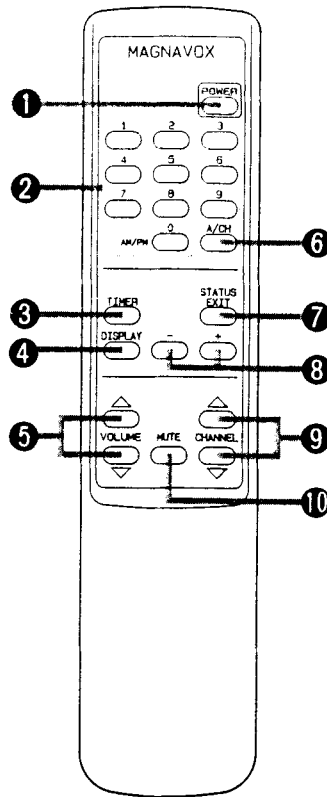

❶ POWER

Press the Power button on the Remote Control once to turn the set ON. Press it again to turn the set OFF.

❷ NUMERIC CHANNEL BUTTONS

Direct channel selection. For channels 1 through 9, press the "0" button first and then your desired channel number (For example: for channel 4 press 0-4, not 4). For channels 10 through 99, press the two digits in order (for channel 26 press 2-6). Be sure to press the second digit within 3 seconds after the first digit or the set will select the channel only for the first number pressed. The "0" button also selects AM or PM when setting the clock or timer.

❸ TIMER

Use this button to set clock, sleep time, every day timer and one time timer.

❹ DISPLAY

Press this button to choose between the different on-screen display modes. The on-screen display remains for 12 seconds after pressing this button.

❺ VOLUME-UP, DOWN

Press either the Volume (Up) or (Down) button to increase or decrease the sound level as desired. (The volume level is displayed on the screen when the level is changed.)

❻ A/CH

This button allows you to go back to the previous viewed channel. For example: If you select channel 11 and then switch to channel 2, using the channel number buttons, just press the A/CH button and the TV set will automatically be switched to the previous channel. Press the A/CH button again to return to channel 2.

❼ STATUS/EXIT

Press the Status/Exit button to display the Channel being viewed and clock. Press again to turn off display.

NOTE: This feature does not work in the program mode.

❽ SELECT BUTTON (+, -)

These buttons are used for adjusting, selecting or cancelling functions.

❾ CHANNEL-UP, DOWN

To change the channel, press either the Channel Up or Down button. If you press and hold either button, the channels will continue to change. The number of the channel being viewed will be displayed on the screen.

❿ MUTE

Press the Mute button to turn off the sound portion of the program. (When the Mute button is pressed, "MUTE" display will appear in red.) This is convenient when answering a telephone. Press the Mute button again or press Volume Up or Down to restore sound.

When Turned On For The First Time

1. Press the power switch. CH3 and ++:++AM appear on the screen as shown in.
2. Set the clock. (Refer to the section SETTING THE CLOCK.)
3. Preset the channels. (Refer to the section AUTOMATIC CHANNEL PROGRAMMING.)

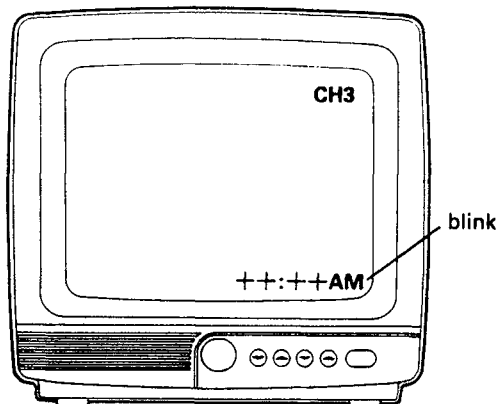

Operating Procedure

TV Operation

- 1 Press the Power button.
- 2 Press the Display button to display TV/A/V adjustment screen. Press — button to place in TV mode. (See Audio/Video section for operations using accessory A/V equipment.)
- 3 Press the Display button again to display NORMAL/CABLE adjustment screen. Press — button to select NORMAL (ANTENNA) mode. (See Cable TV Operation section for cable systems.)
- 4 Press the Display button to display PICTURE ADJUST/RESET adjustment screen. If you want to adjust color and picture controls, press — button. (Refer to the section HOW TO ADJUST FOR THE BEST PICTURE.)
- 5 Press the Display button to display PROGRAM CH MANUAL/AUTO. If you want to program channel numbers into the TV scanning system manually, press — button. (Refer to the section MANUAL CHANNEL PROGRAMMING.)
- 6 Press Exit button to clear the screen.

- 7 Press the Channel ▲ (Up)/ ▼ (Down) buttons to select a desired channel. You can also select a desired channel directly with number buttons on the Remote Control unit.
- 8 Press the Volume ▲ (Up)/ ▼ (Down) buttons to increase or decrease the volume level as desired. The volume level is displayed on the lower portion of the screen with a bar graph.

NOTE: If you desire to check the channel number you are watching or to display the channel number, press the Status/Exit button on the Remote Control unit. The channel number and time display will appear on the screen.

NOTE: If you want to return to the normal mode after pressing — or + button, press Status/Exit button once or press display button until normal mode.

NOTE: Each adjustment screen remains for approximately 12 seconds then disappears.

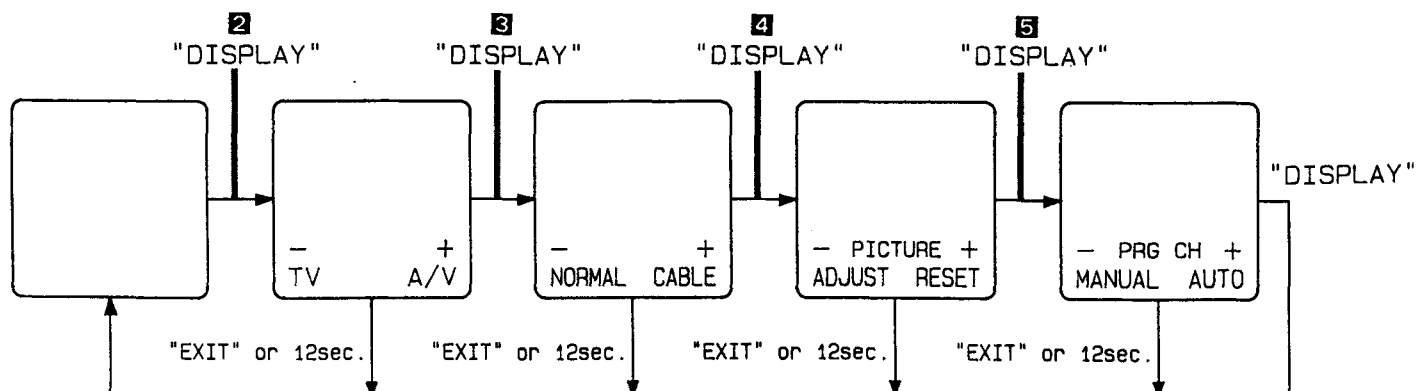

Setting The Clock

(Can Only Be Done With Remote Control Unit)

1 Press the Timer button. ++:++ AM will blink or digits indicating the time will appear on the screen.

NOTE: When resetting the time, press + button to initiate the reset sequence, time digits will blink.

2 Set the current time by using the number buttons 0-9.

NOTE: When setting time you must enter four digits. For hour 1-9 enter "0" first, then desired time.

3 When the current time is displayed on the screen, press + button. The time stops blinking and "AM" or "PM" begins to blink.

4 Select "AM" or "PM" with the number button "0" (AM/PM).

5 Press + button. The "AM" or "PM" stops blinking.

6 After setting the correct time, press Exit button. The Time display will disappear from the screen.

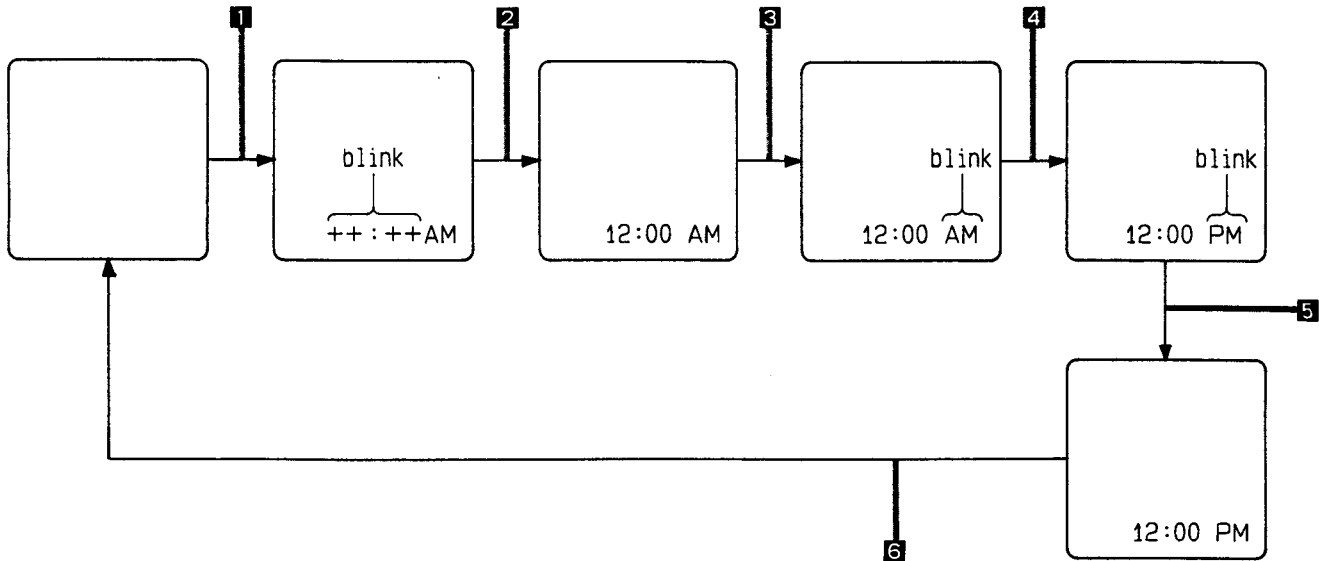

Setting The Timers

(Can Only Be Done With Remote Control Unit)

EVERY DAY TIMER

You can set the Timer to have the TV turn on a specific channel at the same time everyday.

(See opposite page for illustration steps)

1 Press the Timer button three times to set the EVERY DAY timer setting mode.

2 If EVERY DAY timer has never previously been set, "++ ++:++ AM" blinks, enter the desired channel number using the Number buttons (enter "0" before single digit channels). Then press + button. Digit(s) indicating the desired channel will appear and the "++:++" or digits indicating the time will blink.

NOTE: If resetting EVERY DAY timer, press the + button to initiate reset sequence, then enter the desired channel.

3 Set the desired turn on time using the Number buttons 0-9, then press the + button.

4 The "AM" or "PM" indicator will blink. Select "AM" or "PM" with the "0" ("AM/PM") number button.

5 Press the + button.

6 Press the Status/Exit button.

ONE TIME TIMER

You can set the timer to have the TV turn on a desired channel at a preselected time.

(1) Press the Timer button in four times to set the ONE DAY timer setting mode.

(2) Follow the steps (2) ~ (6) of EVERY DAY TIMER SECTION.

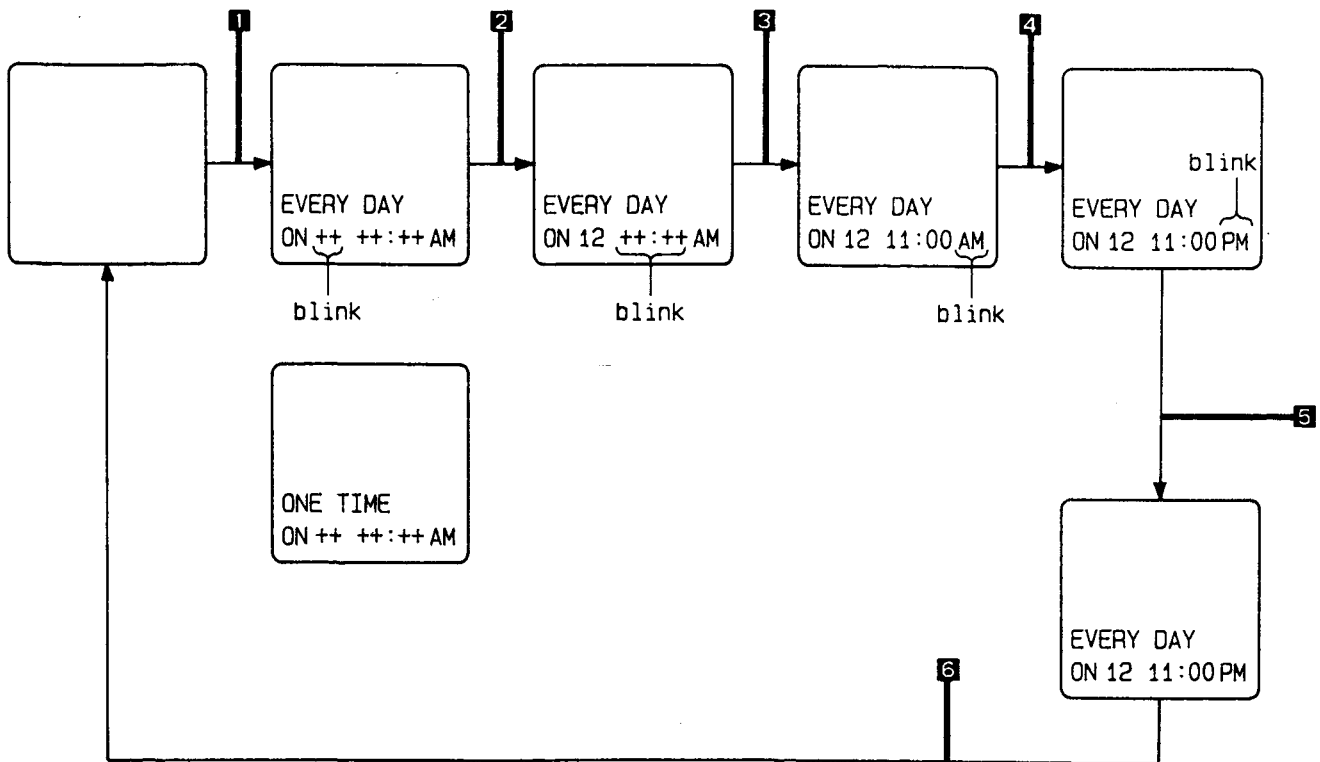

Automatic Channel Programming

This function allows you to automatically program locally available channels into the TV scanning system.

- 1 If not in the program mode, press the Display button until PRG CH MANUAL/AUTO displays on the screen. Press + button.
- 2 The channel number will continue to change until the next active channel is found.
- 3 The color of the channel number on the screen automatically changes from red to green when the channel is programmed (added into the TV scan system).
- 4 The unit sequences through all the channels until the last active channel is found.
- 5 When auto channel programming is completed, the lowest programmed channel reappears on the screen.
- 6 Press the Exit button to clear the screen.

Manual Channel Programming

This function allows you to program locally available channels manually into the TV scanning system.

- 1 If not in the program mode, press the Display button until PRG CH MANUAL/AUTO displays on the screen. Press - button to select MANUAL. The red color of a channel number will indicate that this channel has not been programmed (added into the TV scan system).
- 2 Press channel ▲ (Up)/▼ (Down) button (or numeric channel buttons on the Remote Control) to select a desired channel.
- 3 Press the + button. The channel number on display changes color from red to green, indicating the channel is programmed.
- 4 Repeat steps (2) and (3) to set any other channels.
- 5 Press the Exit button to clear the screen.

To Cancel Programmed Channels

- 1 Press the Display button until MANUAL/AUTO displays on the screen. Press - button to select MANUAL.
- 2 Press Channel ▲ (Up)/▼ (Down) button (or use number buttons on the Remote Control) to select the channel you wish to cancel (or drop from TV scan system).
- 3 Press the - button. The channel color changes from green to red.
- 4 Repeat steps (2) and (3) to cancel other channels.
- 5 Press the Exit button to clear the screen.

NOTE: If the AC cord is unplugged or a power failure occurs for an extended period (more than 30 min.), it may be necessary to re-program the desired channels.

Cable TV Operation

In CATV (Cable Television) systems, programs are brought into the home on VHF channels 2-13, mid-band channels A-I, super band channels J-W, hyper band channels AA-CCC, ultra band channels W + 30 – W + 58, and sub-midband channels (5A, A5-A1). Press the Display button until NORMAL/CABLE select displays on the screen. Press + button to receive these cable channels. Channels 2 through 13 are selected directly. Channel A can be tuned in by selecting number 14 on this TV, channel B by selecting number 15, and so on as follows:

Channel number on TV		14	15	16	17	18	19			
Corresponding CATV Channel		A	B	C	D	E	F			
20	21	22	23	24	25	26	27	28	29	30
G	H	I	J	K	L	M	N	O	P	Q
31	32	33	34	35	36	37	38	39	40	41
R	S	T	U	V	W	AA	BB	CC	DD	EE
						W+1	W+2	W+3	W+4	W+5
42	43	44	45	46	47	48	49	50	51	52
FF	GG	HH	II	JJ	KK	LL	MM	NN	OO	PP
W+6	W+7	W+8	W+9	W+10	W+11	W+12	W+13	W+14	W+15	W+16
53	54	55	56	57	58	59	60	61	62	63
QQ	RR	SS	TT	UU	VV	WW	XX	YY	ZZ	AAA
W+17	W+18	W+19	W+20	W+21	W+22	W+23	W+24	W+25	W+26	W+27
64	65	66	67	68	69	70	71	72	73	74
BBB	CCC									
W+28	W+29	W+30	W+31	W+32	W+33	W+34	W+35	W+36	W+37	W+38
75	76	77	78	79	80	81	82	83	84	85
W+39	W+40	W+41	W+42	W+43	W+44	W+45	W+46	W+47	W+48	W+49
86	87	88	89	90	91	92	93	94	95	96
W+50	W+51	W+52	W+53	W+54	W+55	W+56	W+57	W+58	A5	A4
97	98	99	1							
A3	A2	A1	5A							

Most CATV systems use letters to designate channels but others use numbers. To tune in a numbered channel, select the same number on the TV. Consult your local Cable TV company to find out which of these channels are receivable and which type of Cable system is used in your area. (Some cable TV systems use scrambled or encoded signals and require special converters to receive these channels.)

Channel And Volume Memory

When the TV set is turned off with the Power switch, the last channel selected and volume level remain in the same position.

Sleep Timer Operation

The Remote Control has a count down timer which automatically turns the TV off at the end of the preset time.

- 1 Push the Timer button until SLEEP++ appears on the TV screen in place of the time display.
- 2 Push the + button repeatedly to set the desired sleep time (10, 20, 30... or 90 minutes). When the button is released, the timer will begin counting down. To turn off the sleep time display, press Status/Exit button once or press Timer button until return to the normal mode.
- 3 You can check the time remaining for a sleep timer setting by pressing the Status/Exit button once. To turn off the sleep time display, press Status/Exit button once again.

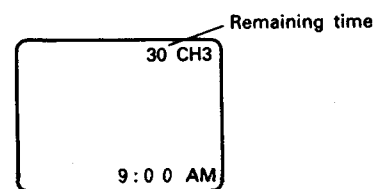

- 4 To cancel the sleep timer function, press the Timer button to SLEEP mode. Press the + button until the "++" displays or press the Power button to turn the TV OFF.

Remote Control Battery Requirements

The Remote control unit requires two 1.5 volt "AA" size batteries. The Battery Compartment is located on the back of the unit. To open, press down on the lid and slide toward the bottom of the unit. Install the batteries exactly as shown by the diagram in the compartment.

NOTE: If one or both of the batteries are reversed the Remote Control will not operate and the unit may be damaged.

This Remote control unit uses an infrared wireless control system. This means that the remote commands are sent out as invisible light. For best operation, be sure to operate the Remote control within its 24' (approximate) range and aim the Remote control directly at the Remote Control Sensor window on the lower front of the TV. Please note that furniture or other solid objects can block the path of the infrared light. Dark walls might absorb the light. Do not allow strong sunlight to fall on the front panel of the TV as this may affect the operation of the remote control. In this case, turn the TV away from the light or darken the room slightly.

NOTE: The remote control will be inoperable if the batteries lose their charge. Replace them with new batteries.

Audio/Video Input Jack Operation

Video Input And Audio Input Jacks

Your TV set is equipped with Video and Audio input jacks. This feature allows the TV to be used to monitor audio and video signals from other sources such as a VCR, Camera, Computer etc.

Playing Back From A VCR Or Monitoring A Camera, Computer etc.

- 1 Connect A/V cables (not included) from the Audio output and Video output jacks on the VCR, Camera or Computer to the Audio input and Video input jacks on the TV set, as shown.
- 2 Press Display button until TV/A/V mode select displays on the screen. Then press + button to place in A/V mode.
- 3 Press the Status/Exit button.
- 4 Operate the VCR, Camera or Computer in a normal manner (as described in its Operating Manual). The TV will monitor what is being played or recorded on the VCR, Camera or Computer.

NOTE: When you turn the TV OFF and then back ON while in the Video mode, the TV/A/V mode remains in the A/V mode.

NOTE: After enjoying the VCR or video camera playback, remember to set the TV/A/V mode to the TV mode in order to resume normal TV viewing.

NOTE: When pressing the Numeric channel, channel-up, down or Status/Exit button in A/V mode, "A/V" display will appear on the screen.

External Speaker Jack Operation

You may connect a 8-ohm speaker (not supplied) with a 3.5 mm input plug to Ext. Speaker Jack on the TV. The built-in TV speaker is disconnected automatically.

Earphone Jack Operation

Insert an Earphone (SBA2117A01) (not supplied) plug into the Earphone jack for private listening. When using the earphone, the internal speaker is automatically shut off.

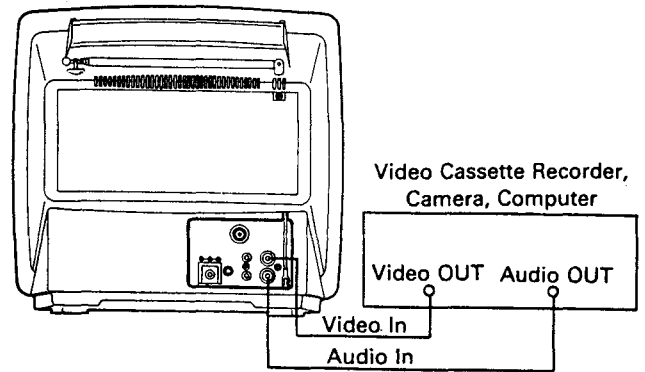

To order any optional cables or other accessories contact your dealer or call the toll-free accessory ordering number (1-800-292-6066).

How to Adjust For The Best Picture

- 1 Press the Display button until Picture Adjust/Select mode appears on the screen. Then press - button to select the Adjust Picture.
- 2 Press the Display button until the picture adjustment (Contrast, Brightness, Tint, Color and Sharpness) you wish to change appears on the screen.
- 3 Press the - or + button to adjust the selected function to your preference. A bar scale is displayed at the bottom of the screen as the change is made.

4 After adjustment, press Exit button.

NOTE: When picture adjust mode appears on the screen, pressing + button resets all functions to their center adjustment position.

See chart below:

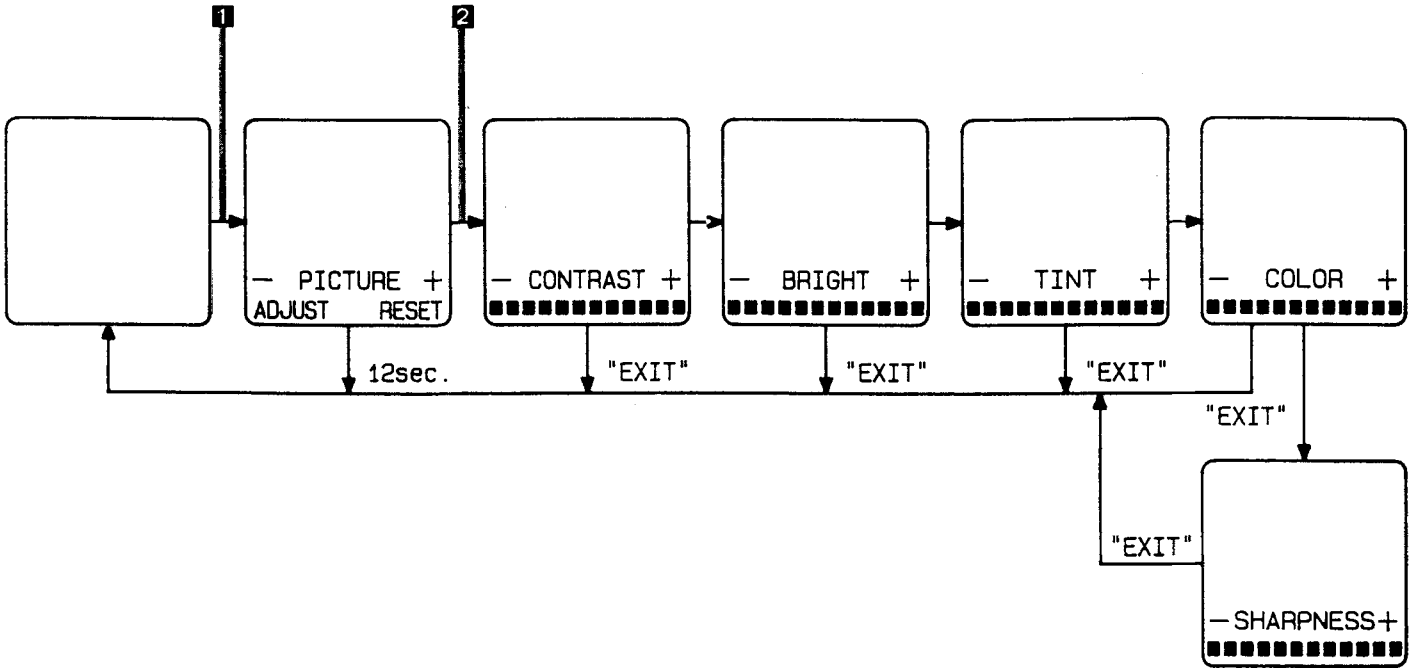

Operating Chart

		FUNCTION	
		- Button ←	→ + Button
Display Button	CONTRAST	Weak	Strong
	BRIGHTNESS	Dark	Light
	SHARPNESS	Soft	Sharp
	COLOR	Pale	Deep
	TINT	Skin tones become purplish	Skin tones become greenish

NOTE: Channel number is not displayed in the picture control mode.

Before Calling For Service

Remember! Charges for TV installation, adjustment of customer controls or repair of antenna systems outside the TV are not covered under your warranty. Be sure to make these simple checks before calling for service. These tips can save you time and money.

Problem	Action
No Power	<ul style="list-style-type: none">* Unplug set from wall outlet 60 seconds. Then replug set into outlet and switch TV ON again.
No Picture	<ul style="list-style-type: none">* Check that antenna lead terminal connection is properly connected at the set.* Check connections on the antenna.* Check the TV/AV display for correct position. The A/V mode with no signal source will create a blank screen.
No Sound	<ul style="list-style-type: none">* Check the Volume control.* Check the Mute button.
No Color	<ul style="list-style-type: none">* Check COLOR setting.* Is station transmitting color? Try another channel.
Wrong Color	<ul style="list-style-type: none">* Adjust COLOR and TINT controls.
Picture too light or too dark	<ul style="list-style-type: none">* Adjust the BRIGHT and CONTRAST controls.
Picture Interference	<ul style="list-style-type: none">* Check antenna for shorted or broken lead-in wires.* Reposition antenna.* Possible station trouble or local interference (electric motors, etc.). Try another channel or adjust the antenna to minimize.
Remote control not working	<ul style="list-style-type: none">* Check the batteries.

LIMITED WARRANTY

LIMITED WARRANTY

Color Television

- 90 Day Carry-In Service Labor Warranty
- One (1) Year Exchange On Warranty Parts
- Two (2) Year Exchange Warranty on Color Picture Tube
- * For purchases in Canada, refer to Canadian Warranty.

This warranty gives you specific legal rights and you may have other rights which vary from state to state.

Parts and Labor During First 90 Days

For Ninety (90) Days from the date of purchase, an Authorized Service Center will repair any product defect and replace any defective part, including the picture tube without charge to you for parts or labor.

Replacement Parts After 90 Days

If within one (1) year - two years for a picture tube- after the date of purchase, a part is found defective and needs to be replaced, an Authorized Service Center will supply to you a new or, at our option, rebuilt part without charge to you for the replacement part. After 90 days from the date of purchase, you must pay for all labor, transportation and service charges. Replacement parts and picture tubes installed during the TV warranty period are warranted only for the balance of the original TV warranty period.

Who Is Protected?...Where?

This warranty is extended to the original retail purchaser for products purchased and used in the U.S.A., Puerto Rico and the Virgin Islands. If you move within these areas, an Authorized Service Center in your area will honor this warranty for the remainder of the original warranty period.

YOU MUST PRESENT PROOF OF THE DATE ON WHICH THE TV WAS FIRST PURCHASED (SALES RECEIPT OR OTHER EVIDENCE) WHEN REQUESTING SERVICE OR REPLACEMENT PART WARRANTY PERFORMANCE.

What the Purchaser Must Do

Before you call for service, check your operating instruction booklet. A slight adjustment of the customer controls discussed in your instruction booklet may save you a service call.

If you require service during the warranty period, you must take your TV to an Authorized Service Center and pick it up after completion of service. The Service Center must be allowed to keep defective parts. After the first 90 days of the warranty period, the cost of service labor is your responsibility.

Warranty service will be performed by an Authorized Service Center. We suggest that you contact your dealer. If your dealer does not operate an

Authorized Service Center, he will direct you to the Authorized Service Center engaged by him to service the product he sells.

You may also contact the nearest Philips Factory Service Centers (see the Factory Service Center address directory supplied with your product literature) to obtain both In and Out-of-Warranty repair for your product.

Warranty Exclusions

Your Warranty Does Not Cover:

Labor charges for set installation or set-up, adjustment of customer or preference controls, and installation or repair of antenna systems outside the TV set.

Product repair and/or part replacement because of misuse, accident, unauthorized repair or other cause not within the control of Philips Consumer Electronics Company.

Reception problems caused by signal conditions or cable or antenna systems outside the TV.

A television purchased, used or serviced outside the U.S.A., Puerto Rico and the Virgin Islands, or used for commercial or institutional purposes.

Incidental or consequential damages resulting from the product. Some states do not allow the exclusion of incidental or consequential damages, so the above exclusion may not apply to you.

ALL IMPLIED WARRANTIES INCLUDING IMPLIED WARRANTIES OF MERCHANTABILITY AND FITNESS FOR A PARTICULAR PURPOSE, ARE LIMITED IN DURATION TO THE DURATION OF THIS EXPRESS WARRANTY. Some states do not allow limitations on how long an implied warranty lasts, so the above limitation may not apply to you.

IMPORTANT REMINDER

PLEASE FILL OUT AND MAIL YOUR WARRANTY REGISTRATION CARD PROMPTLY. IT WILL BE EASIER FOR US TO NOTIFY YOU IF IT SHOULD EVER BE REQUIRED. THE RETURN OF THE WARRANTY REGISTRATION CARD IS NOT A CONDITION TO WARRANTY COVERAGE.

PHILIPS SERVICE COMPANY
P.O. BOX 555 • JEFFERSON CITY,
TENNESSEE 37760
(615) 475-0317

ST220

