

A stylized logo for 'Color TV' where the text is written in white on a dark, rounded, shield-like shape that appears to be part of a black cord or cable.

## Directions for Use

Model No.: \_\_\_\_\_

Serial No.: \_\_\_\_\_

Important!  
Return your  
Warranty  
Registration Card  
within 10 days.  
See why inside.



### Need help? Call us!

*Philips representatives are ready to help you with any questions about your new product. We can guide you through Connections, First-time Setup, or any of the Features. We want you to start enjoying your new product right away!*

**CALL US BEFORE YOU CONSIDER  
RETURNING THE PRODUCT.**

Visit us on the web at

[www.philips.com](http://www.philips.com)

*Let's make things better.*



**PHILIPS**

**Return your Warranty Registration Card today to ensure you receive all the benefits you're entitled to.**



**Congratulations on your purchase, and welcome to the “family!” To get the most from your PHILIPS product, you must return your Warranty Registration Card within 10 days. So please mail it to us right now!**

**Once your PHILIPS purchase is registered, you're eligible to receive all the privileges of owning a PHILIPS product. So complete and return the Warranty Registration Card enclosed with your purchase at once. And take advantage of these important benefits.**

<p><b>Warranty Verification</b> Registering your product within 10 days confirms your right to maximum protection under the terms and conditions of your PHILIPS warranty.</p>	<p><b>Owner Confirmation</b> Your completed Warranty Registration Card serves as verification of ownership in the event of product theft or loss.</p>	<p><b>Model Registration</b> Returning your Warranty Registration Card right away guarantees you'll receive all the information and special offers which you qualify for as the owner of your model.</p>
--	---	--

**Know these safety symbols**



 This “bolt of lightning” indicates uninsulated material within your unit may cause an electrical shock. For the safety of everyone in your household, please do not remove product covering.

 The “exclamation point” calls attention to features for which you should read the enclosed literature closely to prevent operating and maintenance problems.

**WARNING: TO PREVENT FIRE OR SHOCK HAZARD, DO NOT EXPOSE THIS EQUIPMENT TO RAIN OR MOISTURE.**

**CAUTION:** To prevent electric shock, match wide blade of plug to wide slot, and fully insert.

**ATTENTION:** Pour éviter les chocs électriques, introduire la lame la plus large de la fiche dans la borne correspondante de la prise et pousser jusqu'au fond.

**PHILIPS** Visit our World Wide Web Site at <http://www.philips.com>

# IMPORTANT SAFETY INSTRUCTIONS

## Read before operating equipment

1. Read these instructions.
2. Keep these instructions.
3. Heed all warnings.
4. Follow all instructions.
5. Do not use this apparatus near water.
6. Clean only with a dry cloth.
7. Do not block any of the ventilation openings. Install in accordance with the manufacturers instructions.
8. Do not install near any heat sources such as radiators, heat registers, stoves, or other apparatus (including amplifiers) that produce heat.
9. Do not defeat the safety purpose of the polarized or grounding-type plug. A polarized plug has two blades with one wider than the other. A grounding type plug has two blades and third grounding prong. The wide blade or third prong are provided for your safety. When the provided plug does not fit into your outlet, consult an electrician for replacement of the obsolete outlet.
10. Protect the power cord from being walked on or pinched particularly at plugs, convenience receptacles, and the point where they exit from the apparatus.
11. Only use attachments/accessories specified by the manufacturer.
12.  Use only with a cart, stand, tripod, bracket, or table specified by the manufacturer, or sold with the apparatus. When a cart is used, use caution when moving the car/apparatus combination to avoid injury from tip-over.
13. Unplug this apparatus during lightning storms or when unused for long periods of time.
14. Refer all servicing to qualified service personnel. Servicing is required when the apparatus has been damaged in any way, such as power-supply cord or plug is damaged, liquid has been spilled or objects have fallen into apparatus, the apparatus has been exposed to rain or moisture, does not operate normally, or has been dropped.
15. This product may contain lead and mercury. Disposal of these materials may be regulated due to environmental considerations. For disposal or recycling information, please contact your local authorities or the Electronic Industries Alliance: [www.eiae.org](http://www.eiae.org)
16. **Damage Requiring Service** - The appliance should be serviced by qualified service personnel when:
  - A. The power supply cord or the plug has been damaged; or
  - B. Objects have fallen, or liquid has been spilled into the appliance; or
  - C. The appliance has been exposed to rain; or
  - D. The appliance does not appear to operate normally or exhibits a marked change in performance; or
17. **Tilt/Stability** - All televisions must comply with recommended international global safety standards for tilt and stability properties of its cabinet design.
  - Do not compromise these design standards by applying excessive pull force to the front, or top, of the cabinet which could ultimately overturn the product.
  - Also, do not endanger yourself, or children, by placing electronic equipment/toys on the top of the cabinet. Such items could unsuspectingly fall from the top of the set and cause product damage and/or personal injury.
18. **Wall or Ceiling Mounting** - The appliance should be mounted to a wall or ceiling only as recommended by the manufacturer.
19. **Power Lines** - An outdoor antenna should be located away from power lines.
20. **Outdoor Antenna Grounding** - If an outside antenna is connected to the receiver, be sure the antenna system is grounded so as to provide some protection against voltage surges and built up static charges.
 

Section 810 of the National Electric Code, ANSI/NFPA No. 70-1984, provides information with respect to proper grounding of the mast and supporting structure, grounding of the lead-in wire to an antenna discharge unit, size of grounding connectors, location of antenna-discharge unit, connection to grounding electrodes, and requirements for the grounding electrode. See Figure below.
21. **Object and Liquid Entry** - Care should be taken so that objects do not fall and liquids are not spilled into the enclosure through openings. comply with recommended international global safety standards for tilt and stability properties of its cabinet design.
22. **Battery Usage CAUTION** - To prevent battery leakage that may result in bodily injury, property damage, or damage to the unit:
  - Install all batteries correctly, with + and - aligned as marked on the unit.
  - Do not mix batteries (old and new or carbon and alkaline, etc.).
  - Remove batteries when the unit is not used for a long time.

**Note to the CATV system installer:** This reminder is provided to call the CATV system installer's attention to Article 820-40 of the NEC that provides guidelines for proper grounding and, in particular, specifies that the cable ground shall be connected to the grounding system of the building, as close to the point of cable entry as practical.

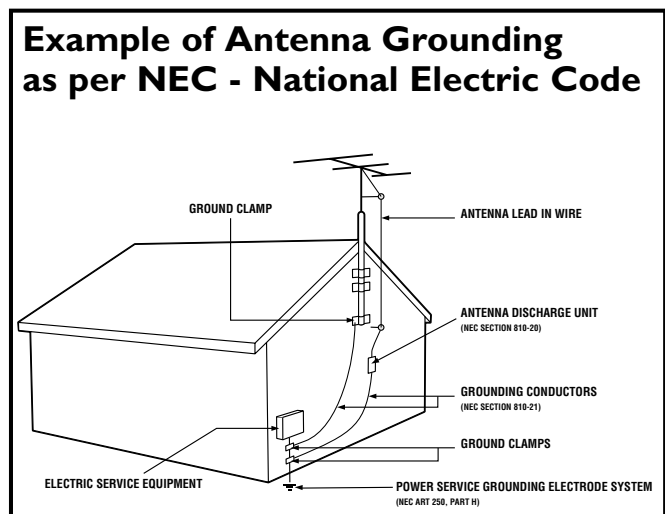

# PANEL LAYOUT

## Side 1

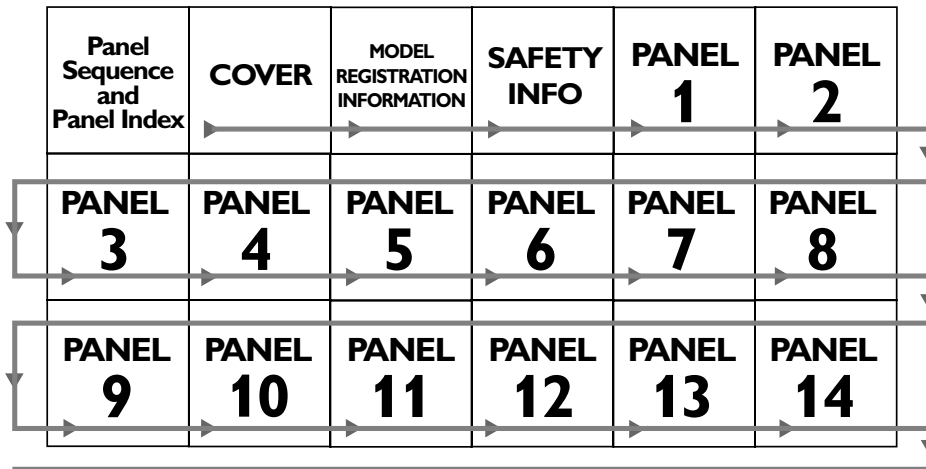

## Side 2

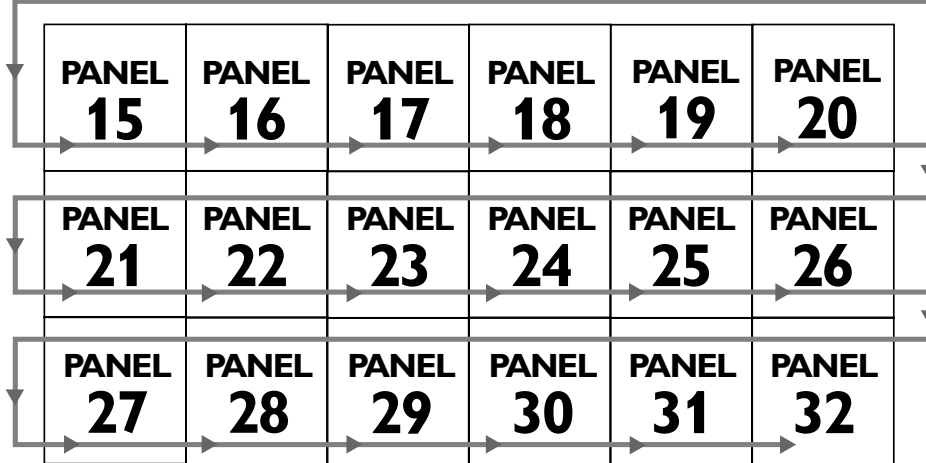

# PANEL INDEX

Subject	Panel No. (Page No.)	Subject	Panel No. (Page No.)
Antenna Basic Connection . . . . .	1 (5)	AutoPicture™ Control . . . . .	26 (30)
Audio/Video Connections		AutoSound™ Control . . . . .	27 (31)
AV1 Input Jacks . . . . .	5 (9)	Basic Remote Operation . . . . .	4 (8)
External Audio System . . . . .	8 (12)	Basic Television Operation . . . . .	4 (8)
Front Audio/Video Input Jacks . . . . .	6 (10)	Cable/Cable Box Basic Connection 2-3	(6-7)
Headphone Jack . . . . .	6 (10)	Closed Caption Control . . . . .	24 (28)
Monitor Output Jacks . . . . .	8-9 (12-13)	Factory Service Locations . . . . .	30-31 (34-35)
S-Video Input Jacks . . . . .	7 (11)	Format Control (4:3 Expand) . . . . .	16 (20)
AutoLock™ Controls		Install Menu Controls . . . . .	13 (17)
Access Code . . . . .	18 (22)	Limited Warranty . . . . .	32 (36)
Block All Channels . . . . .	20 (24)	Onscreen Menu Navigation . . . . .	12 (16)
Block Channels . . . . .	19 (23)	Picture Menu Controls . . . . .	14 (18)
Clear All Blocked Channels . . . . .	20 (24)	QuadraSurf™ . . . . .	28-29 (32-33)
Movie Ratings . . . . .	21 (25)	Remote Batteries . . . . .	4 (8)
Other Blocking Options . . . . .	23 (27)	Remote Control Button Descriptions	
TV Ratings . . . . .	22 (26)	. . . . .	10-11 (14-15)
Understanding AutoLock™ . . . . .	17 (21)	Sleeptimer . . . . .	25 (29)
		Sound Menu Controls . . . . .	15 (19)

Your home's signal input might come from a single (75 ohm) round cable, a Converter Box or from an antenna. In either case the connection to the TV is very easy.

**1** If your Cable TV signal or Antenna signal is a round cable (75 ohm) then you're ready to connect to the TV.

If your antenna has flat twin-lead wire (300 ohm), you first need to attach the antenna wires to the screws on a 300 to 75 ohm adapter.

If you have a Cable Converter Box: Connect the Cable TV signal to the Cable Signal IN(put) plug on the Converter.

**2** Connect the Cable TV cable or Antenna cable (or 300 to 75 ohm adapter) to the 75Ω plug on the TV.

If you have a Cable Converter Box: Connect the OUT(put) plug from the Converter to the 75Ω plug on the TV.

## HELPFUL HINT

Be sure to set the TV for the type signal you've connected (see the "Install Menu Controls" section of this manual.)

To set the TV to select only the channel numbers in your area see how to "Program" or "Add" channels in the TV's memory, see the Auto Program section of this manual.

## Antenna Connection

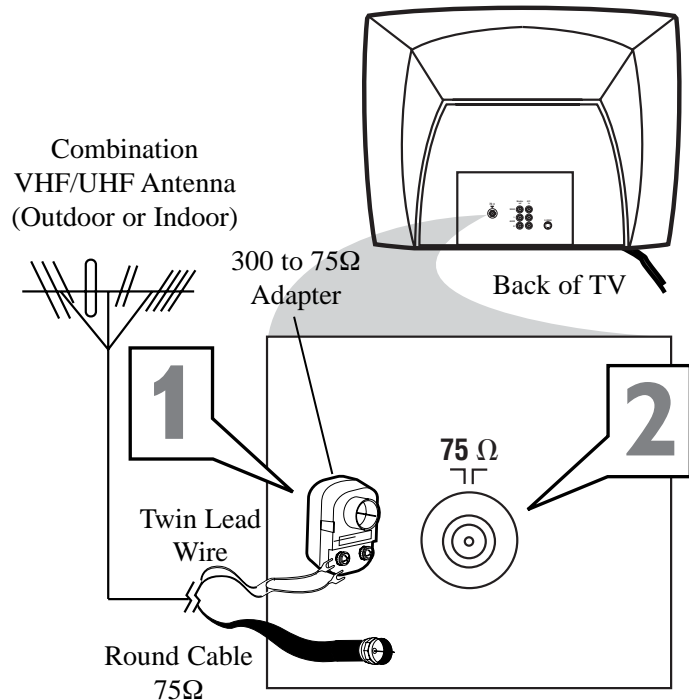

## Cable/Cable Box Connection

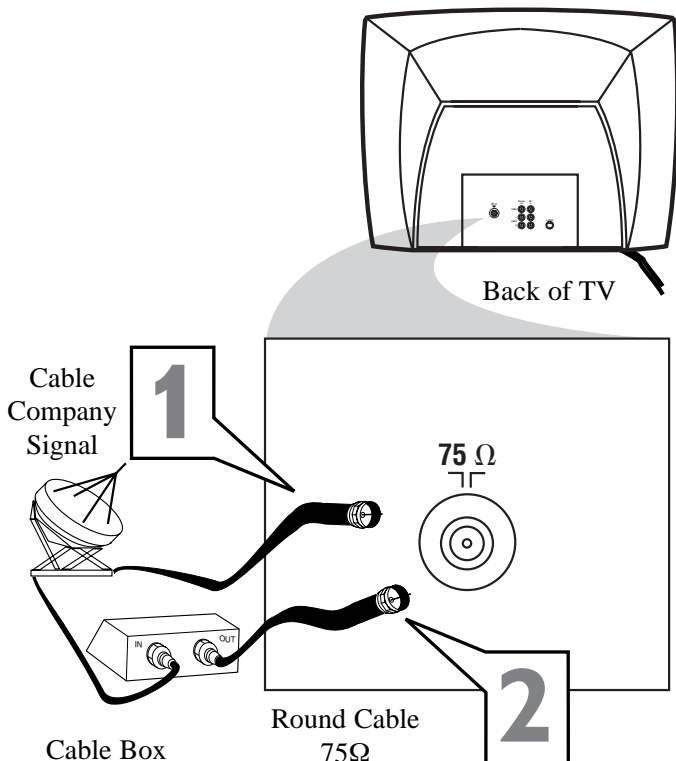

# 2

## CABLE BOX CONNECTIONS

*If you cable signal uses a cable box or decoder, follow the easy steps below to complete the connection.*

### Cable Box (w/RF In/Outputs):

This connection will be mono.

- 1** Connect the Cable Company supplied cable to the signal IN(put) plug on the back of the Cable Box.
- 2** Using a separate round coaxial cable, connect one end to the OUT(put) (TO TV) plug on the back of the Cable Box.
- 3** Connect the other end of the round coaxial cable to the 75Ω input on the back of the television. Screw it down finger tight.

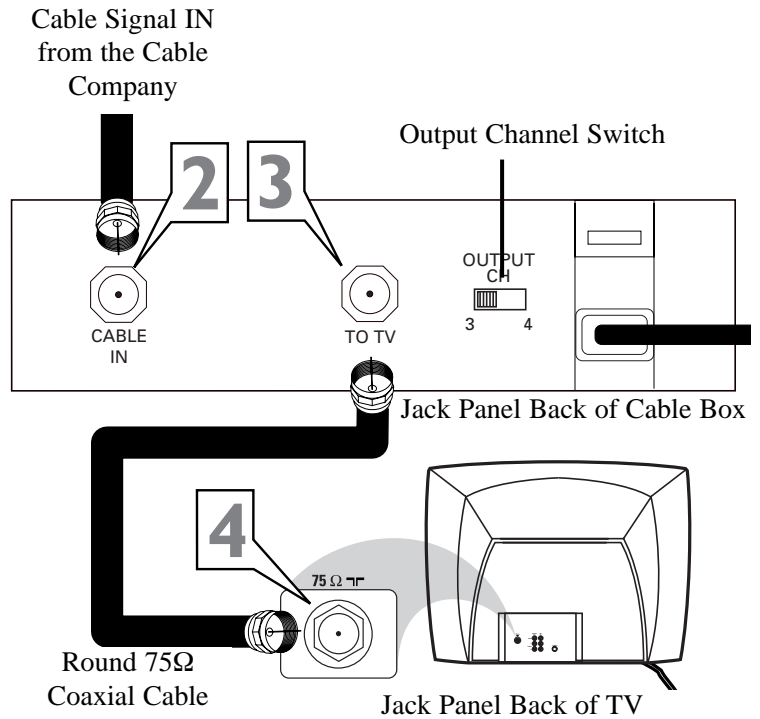

**NOTE:** Set the OUTPUT CHANNEL SWITCH on the back of the cable box to CH 3 or 4. Tune the TV to the same channel and change channels at the cable box.

# 3

## CABLE BOX CONNECTIONS

### Cable Box (w/Audio/Video Outputs):

This connection will supply Stereo sound.

- 1** Connect the Cable Company supplied cable to the cable signal IN(put) plug on the back of the Cable Box.
- 2** Using a RCA type Video Cable, connect one end of the cable to the Video (or ANT, your cable box may be labeled differently) Out jack on the cable box and the other end to the AV1 Video Input on the TV.
- 3** Connect one end of the Audio Left and Right Cable to the left and right Audio Out L & R jacks on the cable box. Connect the other end to the AV1 Audio L & R Input jacks on the TV.

**NOTE:** Use the Channel + or – buttons on the TV remote control to tune to the AV1 channel for the cable box signal. Once tuned, change channels at the cable box, not the television.

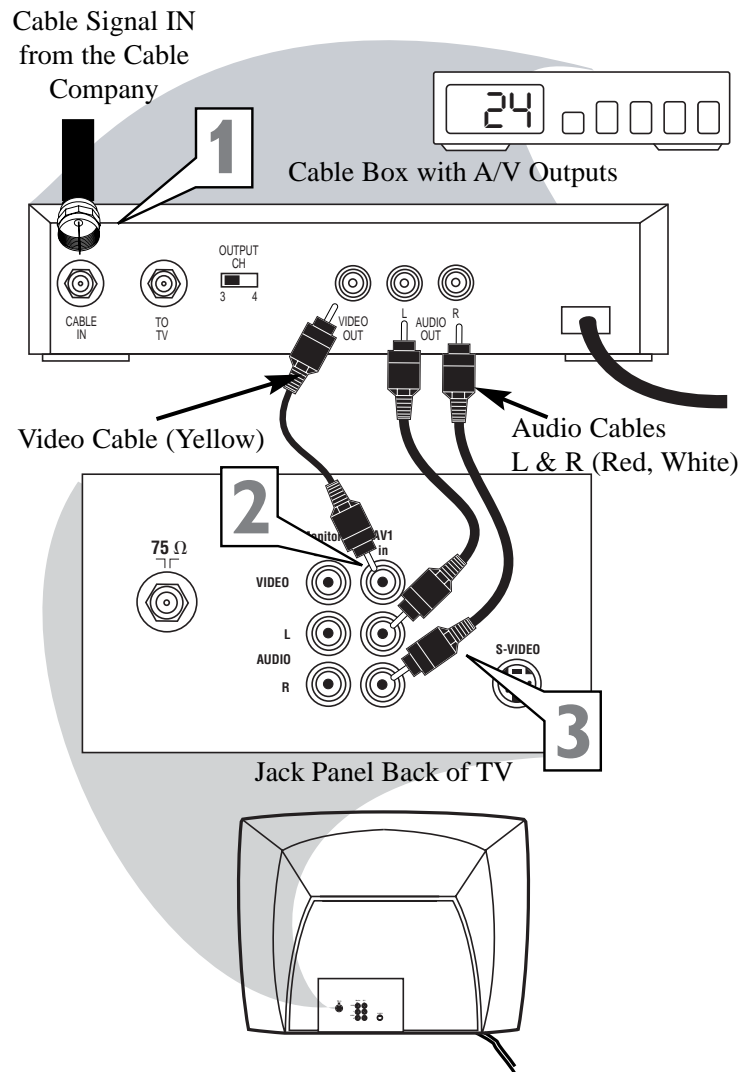

- 1 Press the **POWER** button to turn the TV ON.

Note: You can also press any button on the front of the TV to turn the TV ON.

- 2 Press the **VOLUME +** button to increase the sound level, or the **VOLUME –** button to lower the sound level.

Pressing both buttons at the same time will display the on-screen menu. Once in the menu, use these buttons to make adjustments or selections.

- 3 Press the **CHANNEL UP**  $\wedge$  or **CHANNEL DOWN**  $\vee$  button to select TV channels.

## REMOTE CONTROL

- 4 Point the remote control toward the remote sensor window on the TV when operating the TV with the remote.

*To load the supplied batteries into the remote:*

1. Remove the battery compartment lid on the back of the remote.
2. Place the batteries (2-AA) in the remote. Be sure the (+) and (-) ends of the batteries line up correctly (inside of case is marked.)
3. Reattach the battery lid.

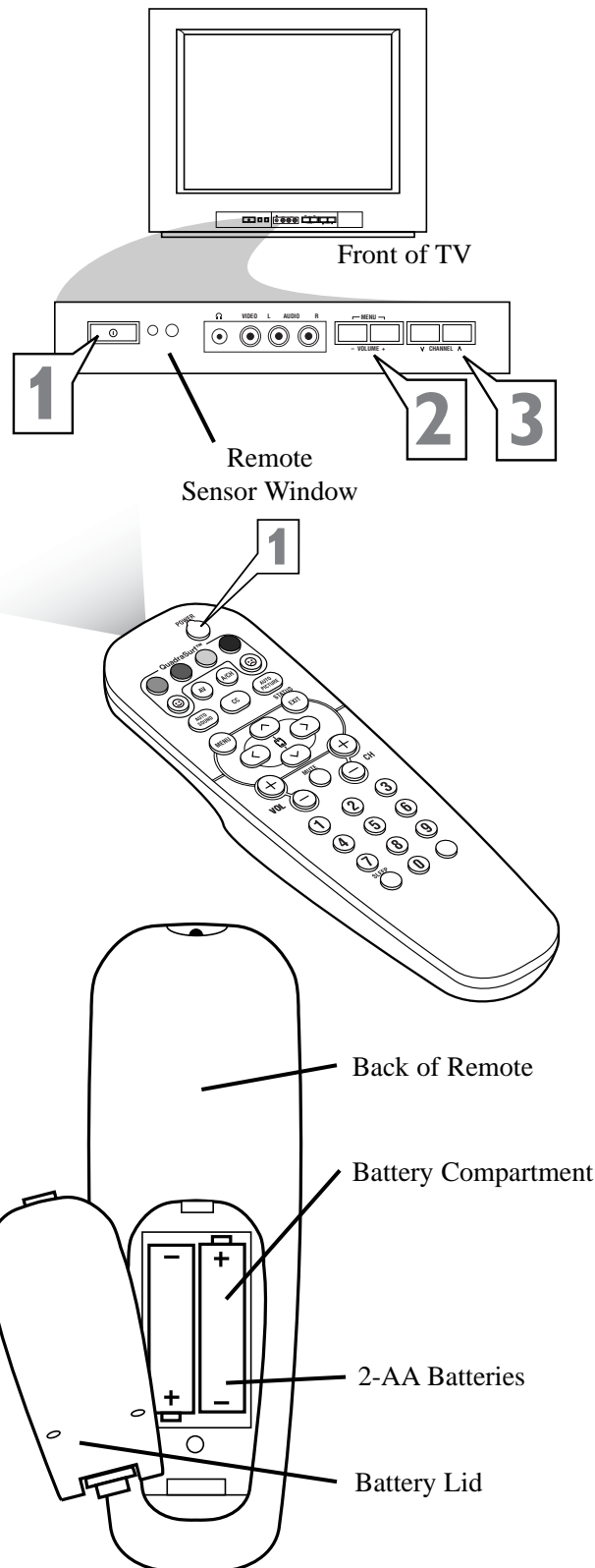



# 5

## AVI AUDIO/VIDEO INPUT CONNECTION

The TV's audio/video input jacks are for direct picture and sound connections between the TV and a VCR (or similar device) that has audio/video output jacks. Follow the easy steps below to connect an accessory device to the AV 1 Input Jacks located on the back of the TV.

- 1** Connect the **VIDEO (yellow)** cable to the VIDEO AV1 in jack on the back of the TV.
- 2** Connect the **AUDIO (red and white)** cables to the AUDIO (left and right) AV1 in jacks on the rear of the TV.
- 3** Connect the **VIDEO (yellow)** cable to the VIDEO OUT jack on the back of the VCR.
- 4** Connect the **AUDIO (red and white)** cables to the AUDIO (left and right) OUT jacks on the rear of the VCR.
- 5** Turn the VCR (accessory device) and the TV ON.
- 6** Press the **AV** button on the remote control to select the AV1 channel. AV1 will appear in the upper left corner on the TV screen.
- 7** With the VCR (or accessory device) ON and a prerecorded tape (CD, DVD, etc.) inserted, **press the PLAY** button to view the tape on the television.

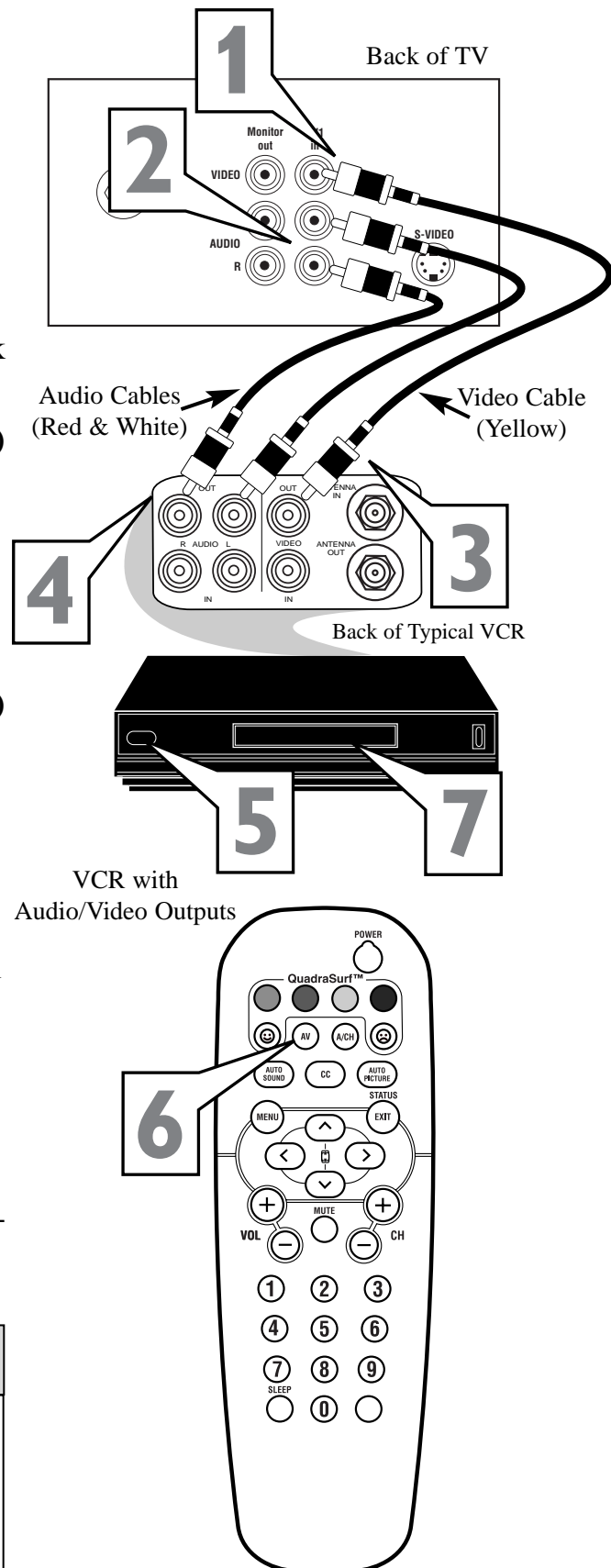

### HELPFUL HINT

All the AV channels can be selected by pressing the Channel + or – buttons. The AV channels can also be added to the QuadraSurf™ buttons for quick access.

## 6

## FRONT AUDIO/VIDEO INPUT CONNECTION

The TV also has Audio/Video Input Jacks located on the front of the TV cabinet for easy and quick connections that might not be permanent. This type of connection might be useful for the playback of a tape from a camera or a video gaming device. Follow the easy steps below to connect an accessory device to the Front Input Jacks.

- 1 **Connect the VIDEO (yellow) cable** to the VIDEO in jack on the front of the TV.
- 2 **Connect the AUDIO (red and white) cables** to the AUDIO (left and right) in jacks on the front of the TV.
- 3 **Connect the VIDEO (yellow) cable** to the VIDEO OUT jack on the back of the camera (or accessory device).
- 4 **Connect the AUDIO (red and white) cables** to the AUDIO (left and right) OUT jacks on the rear of the camera (or accessory device).
- 5 **Turn the camera (or accessory device) and the TV ON.**
- 6 **Press the AV button** on the remote control to select the FRONT channel. FRONT will appear in the upper left corner on the TV screen.
- 7 With the camera (or accessory device) ON and a prerecorded tape (CD, DVD, Game Card, etc., depending on type of accessory device) inserted, **press the PLAY button** to view the tape on the television.

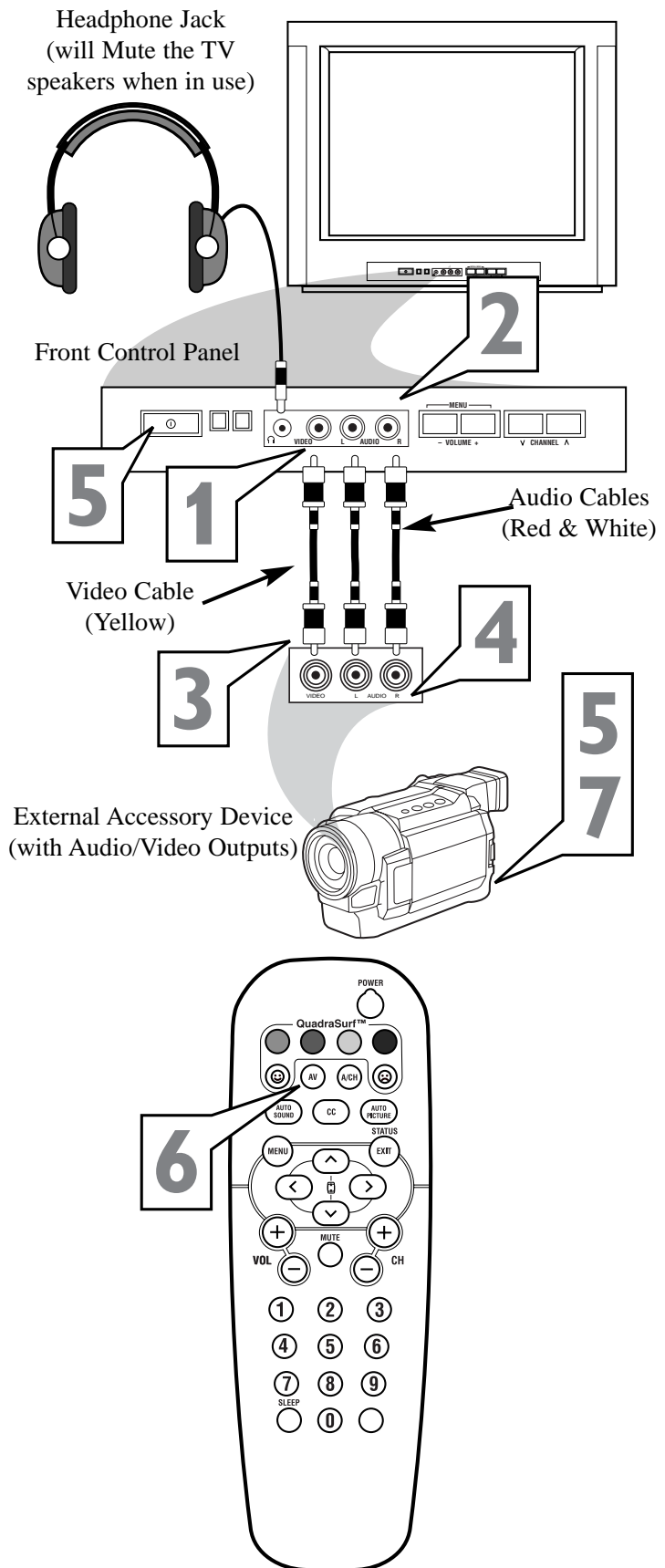

The *S(uper)-Video* connection on the rear of the TV can provide you with better picture detail and clarity for the playback of accessory sources such as DBS (digital broadcast satellite), DVD (digital video discs), video games, and S-VHS VCR (video cassette recorder) tapes than the normal antenna picture connections.

**NOTE:** The accessory device must have an S-VIDEO OUT(put) jack in order for you to complete the connection on this page.

- 1** Connect one end of the S-VIDEO CABLE to the S-VIDEO jack on the back of the TV. Then connect one end the AUDIO (red and white) CABLES to the AV1 in AUDIO L and R(left and right) jacks on the rear of the TV.
- 2** Connect other end of the S-VIDEO CABLE to the S-VHS (S-Video) OUT jack on the back of the VCR. Then connect the other ends of the AUDIO (red and white) CABLES to the AUDIO (left and right) OUT jacks on the rear of the VCR.
- 3** Turn the VCR and the TV ON.
- 4** Press the AV button on the remote to scroll the channels until SVHS appears in the upper left corner of the TV screen.
- 5** Now your ready to place a prerecorded video tape in the VCR and press the **PLAY ►** button.

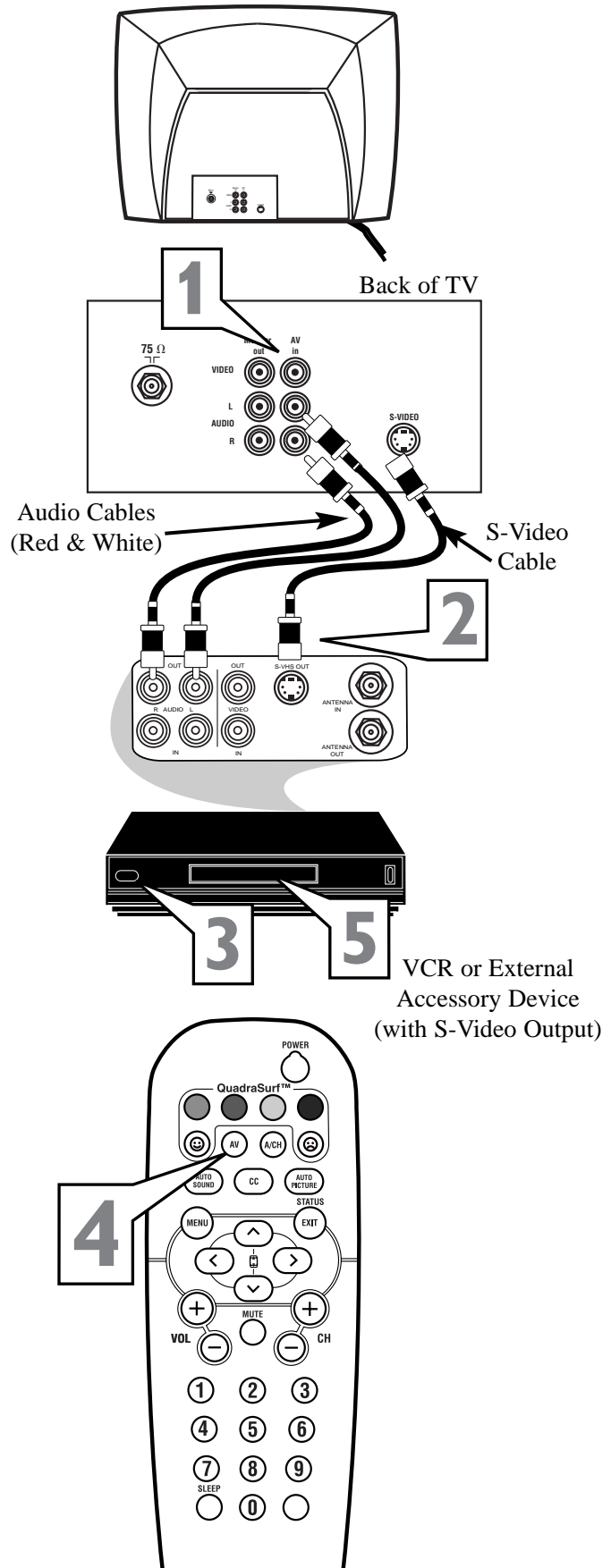

*The Audio/Video (Monitor) Output jacks are great for recording with a VCR or used to connect an external audio system for better sound reproduction.*

### AUDIO SYSTEM CONNECTION:

- 1** Connect one end of the R(ight) and L(eft) AUDIO (Monitor Out) jacks on the TV to the R and L audio input jacks on your amplifier or sound system. Set the television's volume to a normal listening level.
- 2** Turn the TV and audio system ON. To adjust the volume on the audio system, you will need to change the volume at the external audio system, not the television.

### AUDIO SYSTEM CONNECTION:

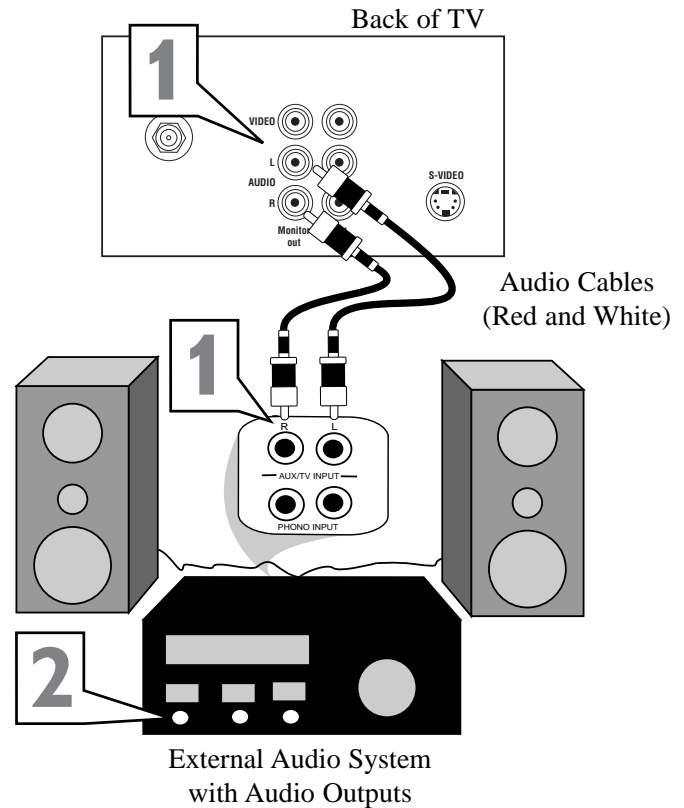

**SECOND VCR CONNECTION:**

**NOTE:** Refer to panel number 5 for the proper hookup of the first VCR. Follow the instructions on how to tune to the AV 1 channel to view a pre-recorded tape.

The following steps allow you to connect a second VCR to record the program while your watching it.

- 1** Connect one end of the yellow Video Cable to the Monitor Out VIDEO plug. Connect the other end to the VIDEO IN plug on the second VCR.
- 2** Connect one end of the red and white Audio cable from the Monitor Out AUDIO L and R plugs on the TV to the AUDIO IN plugs on the VCR.
- 3** Turn the Second VCR ON, insert a black VHS tape and it's ready to record what's being viewed on the TV screen.

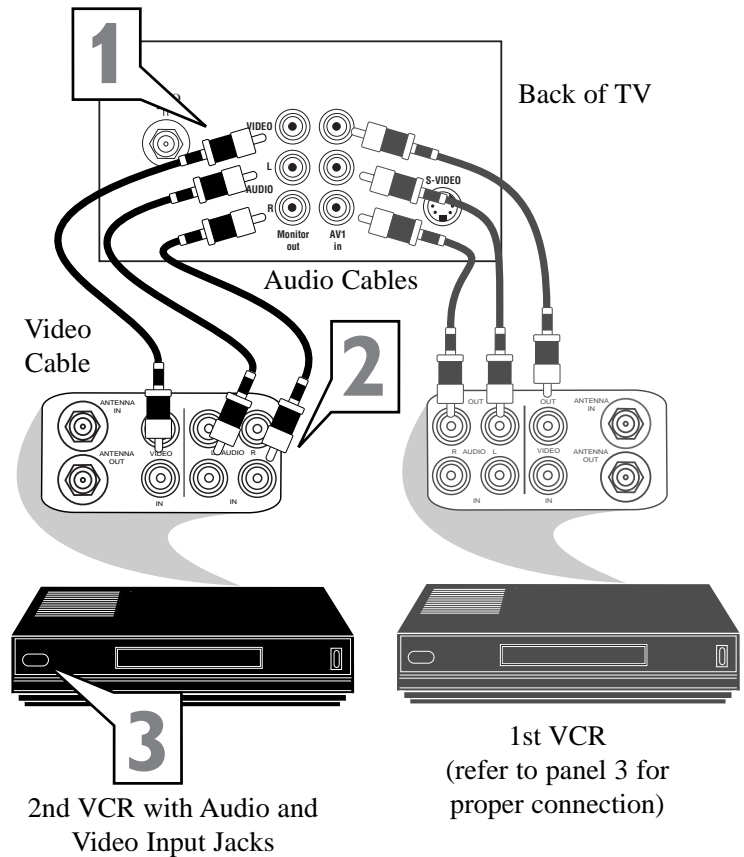
**SECOND VCR CONNECTION:**

**1 - POWER button** - Press the Power button to turn the TV on or off.

**2 - QUADRA SURF Buttons - (Red, Green, Yellow, Blue)** Allows you to store and surf up to 10 channels for each colored button.

**3 - SMILEY Button** - Press to add channels in the “Quadra Surf” lists. Works with all colored buttons.

**4 - FROWNIE Button** - Allows you to delete stored channels within the “Quadra Surf” lists for the colored buttons.

**5 - AV Button** - Press to select an accessory signal from the front AV Inputs.

**6 - A/CH Button - (Alternate Channel)**  
Press to toggle between the last viewed channel and the channel presently being viewed.

**7 - AUTO SOUND Button** - Press repeatedly to choose from 4 different factory pre-defined sound settings. Choose from Personal (how you set the Sound Menu options), Voice (for programming with speaking only), Music (for musical type programs such as concerts), or Theatre (used when watching movies).

**8 - AUTO PICTURE Button** - Press repeatedly to choose from 5 different factory pre-defined picture settings. Choose from Personal (how you set the Picture Menu adjustment controls), Movies (when watching movies), Sports (for any sporting event), Weak Signal (used when the signal being received is not the best), or Multimedia (for use with video gaming).

**9 - CC Button** - Press to activate the Closed Captioning options. Repeatedly pressing the CC button will scroll the options available on the TV screen.

**10 - MENU Button** - Press to display the on-screen menu. Also can be used to back out of the on-screen menu until it disappears from the TV’s screen.

**11 - STATUS/EXIT Button** - Press to display the current channel number. If the on-screen menu is displayed, press the Status/Exit button to remove it from the TV’s screen.

**12 - CURSOR  $\wedge$ ,  $\vee$ ,  $\lt$ , or  $\gt$  Buttons** - Press to navigate, select and adjust controls within the on-screen menu. Also use the CURSOR UP or DOWN  to activate or deactivate the EXPAND 4:3 screen formatting control.

**13 - VOL(ume) + or – Buttons** - Press the VOL + button to increase the TV’s sound level. Press the VOL – button to decrease the TV’s sound level.

**14 - CH(annel) + or – Buttons** - Press to select channels in ascending or descending order.

**15 - MUTE Button** - Press the mute button to eliminate the sound being heard from the TV. “MUTE” will be displayed on the TV’s screen. Press again to restore the TV’s volume to its’ previous level.

**16 - NUMBERED (0-9) Buttons** - Press the numbered buttons to select TV channels or to enter certain values within the on-screen menu. For single channel entries, press the numbered button for the channel you desire. The TV will pause for a second or two before changing to the chosen channel.

**17 - SLEEP Button** - Press the Sleep button to set the TV to automatically turn itself off after a set period of time. Press repeatedly to select 15, 30, 45, 60, 90, 120, 180, or 240 minutes.

**18 - NOTE:** This button is dedicated to TIMER features within certain TV models. This TV does not contain these TIMER features, therefore the button will have no functionality when pressed.



# REMOTE CONTROL BUTTONS

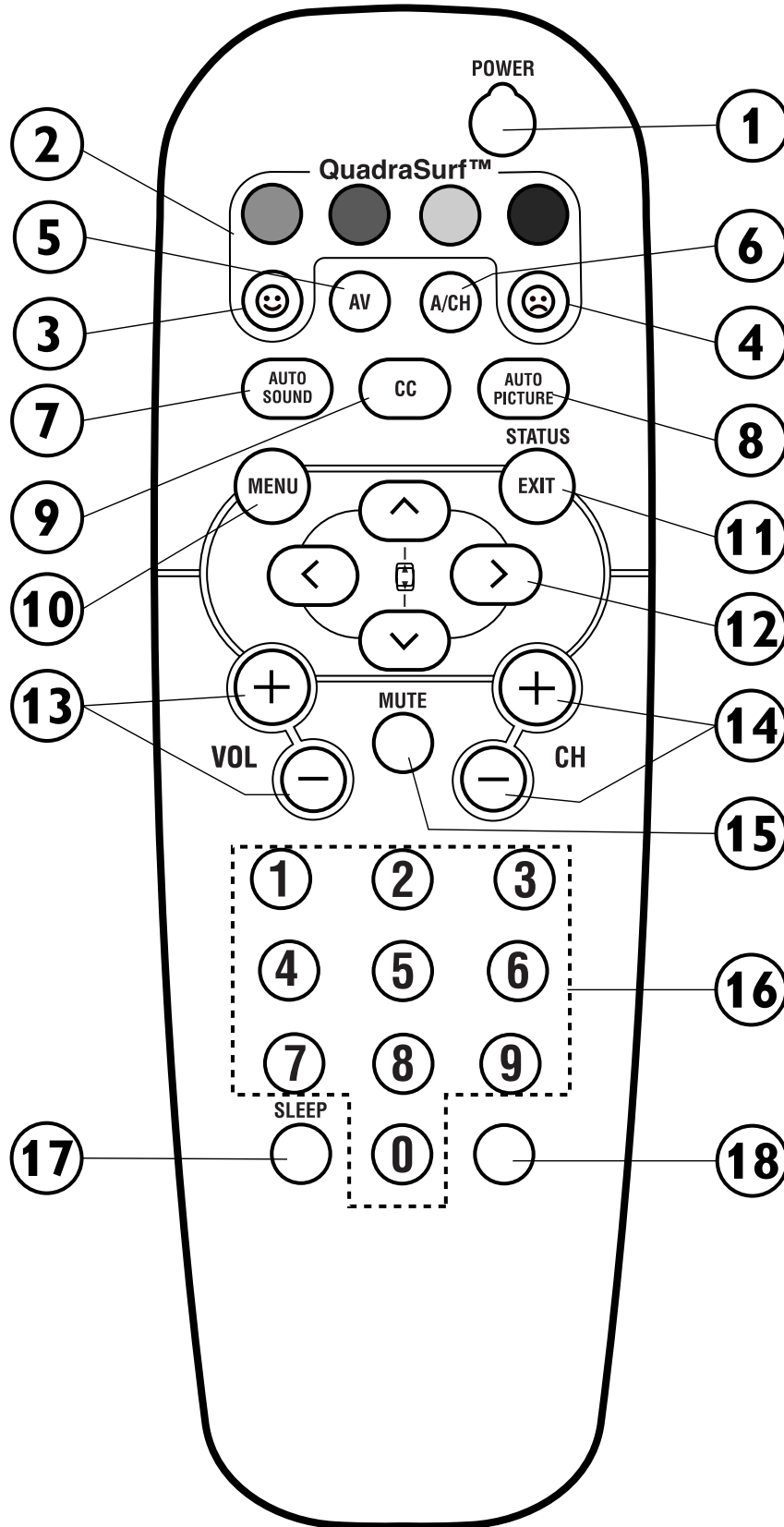

# 12

## HOW TO NAVIGATE THE ONSCREEN MENU

*Features for your television can be adjusted from within a MENU shown on the TV's screen. A MENU is nothing more than an onscreen list of features. Some of the features have sub-menus but each MENU item can be adjusted or activated (deactivated) by viewing the screen and simply pressing the proper button.*

- 1 Press the MENU button** on the remote control to show the onscreen menu.
- 2 Press the CURSOR UP  $\wedge$  or DOWN  $\vee$  buttons** on the remote to pick any of the onscreen menus.
- 3 Press the CURSOR RIGHT  $\>$  button** on the remote control show the selected menu's controls.
- 4 Press the CURSOR UP  $\wedge$  or DOWN  $\vee$  buttons** on the remote to pick any of the displayed controls.
- 5 Press the CURSOR RIGHT  $\>$  or CURSOR LEFT  $\<$  button** on the remote control to make selections or adjustments to the selected controls.
- 6 Press the STATUS/EXIT button** on the remote to clear the menu from the screen after an adjustment.

You can also just wait a few seconds after you finish the feature adjustment and the menu will disappear from the screen automatically.

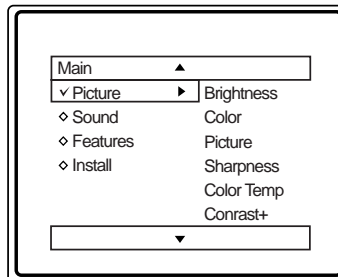

Picture Menu

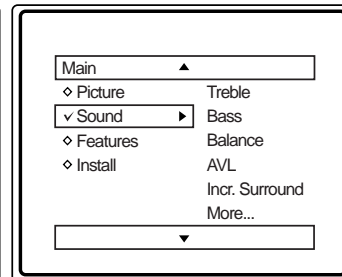

Sound Menu

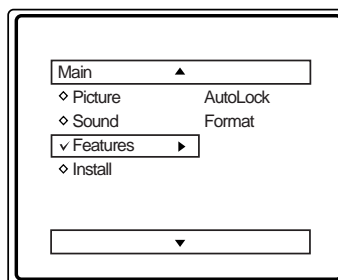

Features Menu

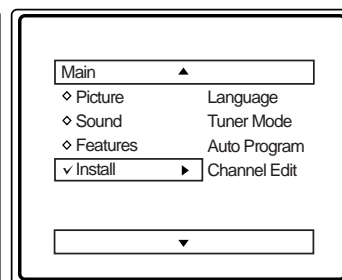

Install Menu

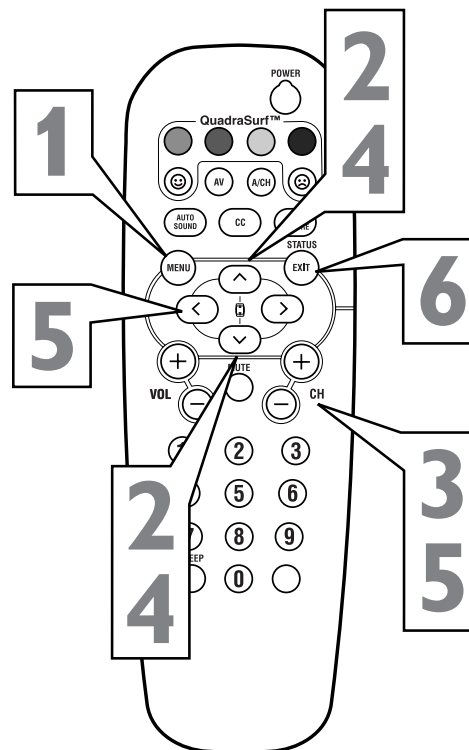



Your TV has several controls to help with the first-time setup. These controls are found within the **INSTALL** onscreen sub menu.

**1 LANGUAGE CONTROL -** For our Spanish and French speaking TV owners an onscreen LANGUAGE Control is present. This control can set the TV's onscreen menu to be shown in either English, Spanish or French.

**2 TUNER MODE CONTROL -** This control changes the TV's signal input to either ANTENNA, CABLE, or AUTO mode. In the AUTO mode, when the AUTO PROGRAM feature is activated, the TV will automatically choose the correct mode.

**3 AUTOPROGRAM CONTROL -** Your TV can automatically set itself for local area (or Cable TV) channels. This makes it easy for you to select only the TV stations in your area when the CHANNEL (+), (-) buttons are pressed. Make sure the antenna or cable signal connection has been completed before AUTO PROGRAM is activated.

**4 CHANNEL EDIT CONTROL -** Allows you to ADD or DELETE specific channels to the TV's memory.

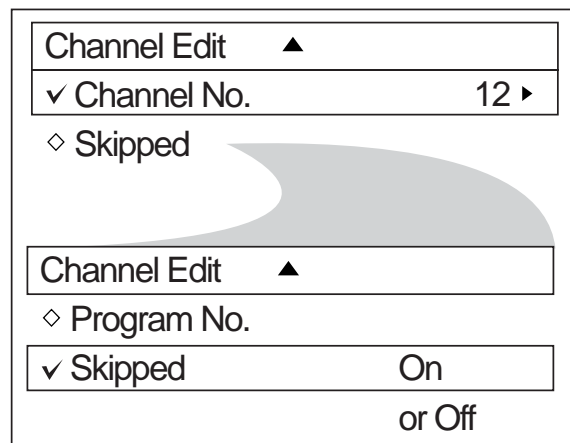
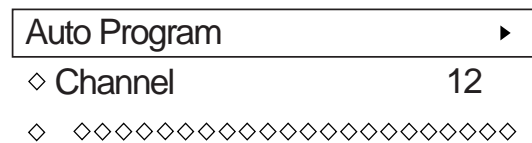
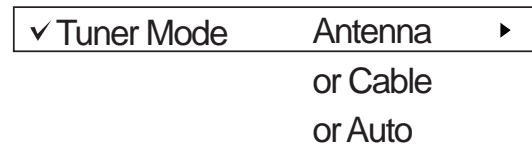
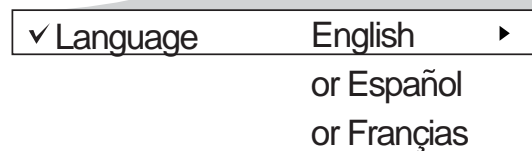
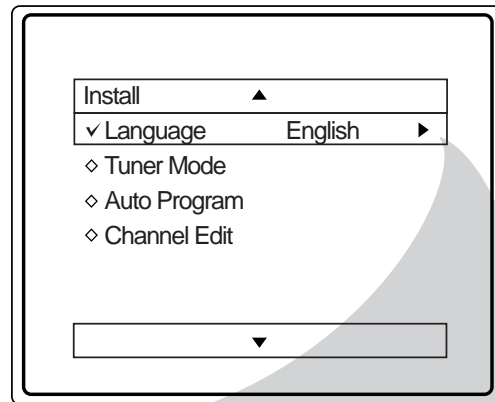

To adjust your TV picture controls, select a channel and use the Picture Menu Controls listed below:

- 1 BRIGHTNESS CONTROL -** Press the **CURSOR RIGHT** > or **LEFT** < buttons until darkest parts of the picture are as bright as you prefer.
- 2 COLOR CONTROL -** Press the **CURSOR RIGHT** > or **LEFT** < buttons to add or eliminate color.
- 3 PICTURE CONTROL -** **CURSOR RIGHT** > or **LEFT** < buttons until lightest parts of the picture show good detail.
- 4 SHARPNESS CONTROL -** Press the **CURSOR RIGHT** > or **LEFT** < buttons to improve detail in the picture.
- 4 TINT CONTROL -** Press the **CURSOR RIGHT** > or **LEFT** < buttons to obtain natural skin tones.
- 5 COLOR TEMP CONTROL -** Press the **CURSOR RIGHT** > or **LEFT** < buttons to select NORMAL, COOL, or WARM picture preferences. (NORMAL will keep the whites, white; COOL will make the whites, bluish; and WARM will make the whites, reddish.)
- 6 CONTRAST + CONTROL -** Press the **CURSOR RIGHT** > or **LEFT** < buttons to toggle the control On or OFF. The Contrast + control helps to “sharpen” the picture quality. The black portions of the picture become richer in darkness and the whites become brighter.

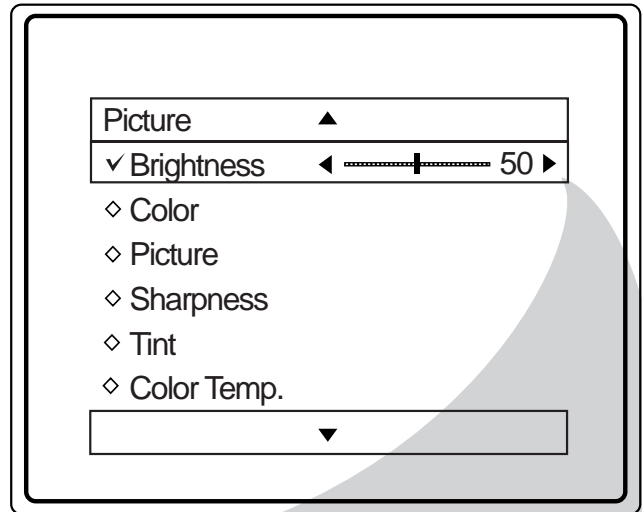

- ✓ Brightness    ◀ ———|——— ▶ 65
- ✓ Color        ▶ ———|——— ▶ 50
- ✓ Picture      ▶ ———|——— ▶ 50
- ✓ Sharpness   ▶ ———|——— ▶ 50
- ✓ Tint           ▶ ———|——— ▶ 0
- ✓ Color Temp.                      Normal  
    Warm  
    or  
    Cool
- ✓ Contrast +                              On  
    Off

To adjust your TV sound, select and use the Sound Menu Controls listed below:

- 1 TREBLE:** Press the **CURSOR LEFT <** or **RIGHT >** buttons to adjust the control. The control will enhance the high frequency sounds.
- 2 BASS:** Press the **CURSOR LEFT <** or **RIGHT >** buttons to adjust the control. The control will enhance the low frequency sounds.
- 3 BALANCE:** Press the **CURSOR LEFT <** or **RIGHT >** buttons to adjust the level of sound coming from the left and right speakers.
- 4 AVL:** (Auto Volume Leveler) Press the **CURSOR LEFT <** or **RIGHT >** buttons to turn the control On or Off. When On, AVL will level out the sound being heard when sudden changes in volume occur during commercial breaks or channel changes.
- 5 INCR. SURROUND:** Press the **CURSOR LEFT <** or **RIGHT >** buttons to select between Incr. Surround or Stereo settings (If Stereo), or select Spatial or Mono (If Mono).
- 6 ULTRA BASS:** Press the **CURSOR LEFT <** or **RIGHT >** buttons to turn Ultra Bass On or Off. Ultra Bass will enhance the low frequency sound.
- 7 SOUND:** Press the **CURSOR LEFT <** or **RIGHT >** buttons to select between Stereo or Mono settings. Note: If Stereo is not present on a selected show and the TV is placed in the Stereo mode, the sound coming from the TV will remain in the Mono mode.

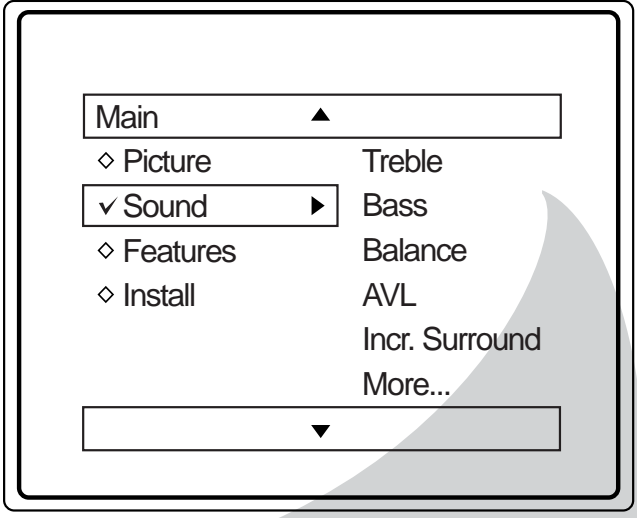

✓ Treble ◀ ———+——— 50 ▶

✓ Bass ◀ ———+——— 50 ▶

✓ Balance ◀ L ———+——— R ▶

✓ AVL On or Off

✓ Incr. Surround Spatial or Mono

✓ Incr. Surround Incr. Surround or Stereo

✓ Ultra Bass On or Off

✓ Sound Mono or Stereo

*Many times while watching movies from a DVD player the image is shown in “letter box” format. This is the format that is shown in movie theaters when shown on a TV screen, the image will have areas of black on top and bottom of the screen.*

- 1** Press the **MENU** button on the remote to display the on-screen menu.
- 2** Press the **CURSOR DOWN**  $\nabla$  button until the word **Features** is highlighted.
- 3** Press the **CURSOR RIGHT**  $\triangleright$  button to display the **Features** menu options (AutoLock or Format).
- 4** Press the **CURSOR DOWN**  $\nabla$  button until the word **Format** is highlighted.
- 5** Press the **CURSOR RIGHT**  $\triangleright$  or **LEFT**  $\triangleleft$  buttons to select one of the two options 4:3 or Expand 4:3.  
**4:3** - Standard format for the TV.  
**Expand 4:3** - Enlarges the picture to fill out the entire screen area, eliminating the “letter box” effect.
- 6** When finished, press the **STATUS** /**EXIT** button to remove the menu from the TV’s screen.

**Note:** The Expand 4:3 format can also be activated using the **CURSOR UP**  $\blacktriangle$  or **DOWN**  $\nabla$  buttons when the onscreen menu is not being displayed. Pressing these buttons will toggle the standard 4:3 format and the Expand 4:3 format.

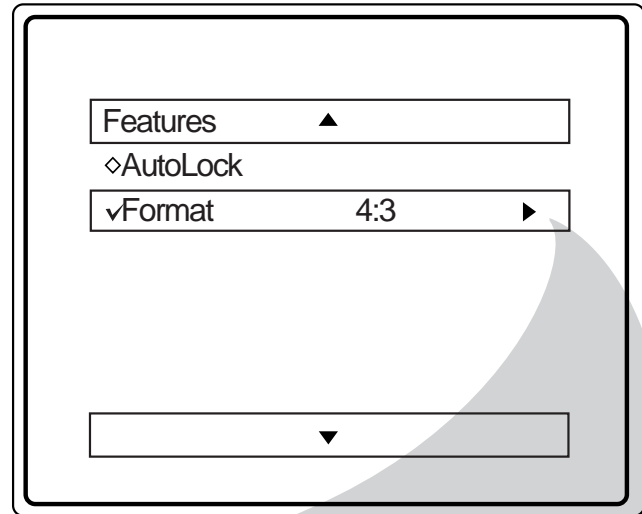

4:3



Expand 4:3

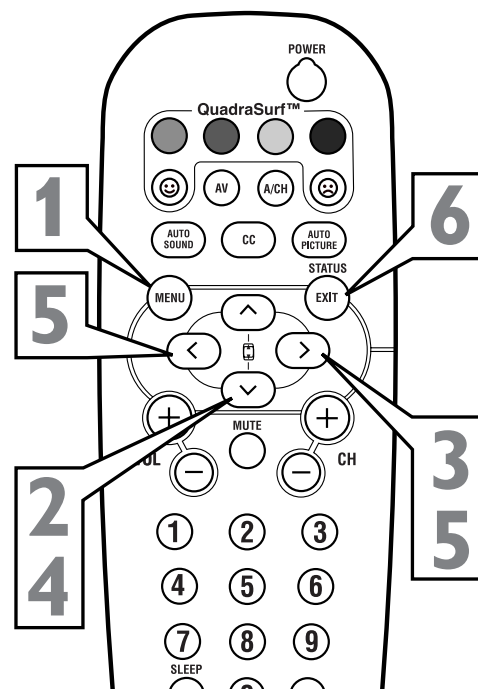

*The AutoLock™ feature is an integrated circuit that receives and processes data sent by broadcasters, or other program providers, that contain program content advisories. When programmed by the viewer, a TV with AutoLock™ can respond to the content advisories and block program content that may be found objectionable (such as offensive language, violence, sexual situations, etc.). This is a great feature to censor the type of viewing children may watch.*

### **AutoLock™ offers various BLOCKING controls from which to choose:**

**Access Code** - An Access Code must be set to prevent children from unblocking questionable or censored programming set by their parents.

**Channel Block** - After an access code has been programmed, you can block individual channels including the A/V inputs.

**Clear All** - Allows you clear all channels being blocked from your viewing set with the Channel Block Control.

**Block All** - Allows you to block ALL channels and A/V inputs at one time.

**Movie Ratings** - Certain blocking options exist which will block programming based on ratings patterned by the Motion Pictures Association of America.

**TV Ratings** - Just like the Movie Ratings, programs can be blocked from viewing using standard TV ratings set by TV broadcasters.

### **MOVIE RATINGS**

**G: General Audience** - All ages admitted. Most parents would find this program suitable for all ages.

**PG: Parental Guidance Suggested** - This programming contains material that parents may find unsuitable for younger children.

**PG-13: Parents Strongly Cautioned** - This programming contains material that parents may find unsuitable for children under the age of 13.

### **MOVIE RATINGS Continued**

**R: Restricted** - This is programming is specifically designed for adults. Anyone under the age of 17 should only view this programming with an accompanying parent or adult guardian.

**NC-17: No one under the age of 17 will be admitted.** - This type of programming should be viewed by adults only.

**X: Adults Only** - This type of programming contains one or more of the following: very graphic violence, very graphic and explicit or indecent sexual acts, very coarse and intensely suggestive language.

### **TV RATINGS**

**TV-Y** -- Designed for a very young audience, including children ages 2-6.

**TV-Y7** --It may be appropriate for children age 7 and above who have acquired the development skills needed to distinguish between make-believe and reality.

**TV-G** -- Suitable for most audiences, this type of programming contains little or no violence, no strong language, and little or no sexual dialogue or situations.

**TV-PG** -- This program contains material that parents may find unsuitable for younger children. Could contain Moderate violence (V), some sexual situations (S), infrequent coarse language (L), or some suggestive dialogue (D).

**TV-14** -- This program contains some material that many parents would find unsuitable for children under 14 years of age. This type of programming contains one or more of the following: intense violence (V), intense sexual situations (S), strong coarse language (L), or intensely suggestive dialogue (D).

**TV-MA** -- This program is specifically designed to be viewed by adults and therefore may be unsuitable for children under 17. This type of programming contains one or more of the following: graphic violence (V), explicit sexual situations (S), or crude indecent language (L).

Over the next few panels you'll learn how to block channels and get a better understanding of the rating terms for certain programming.

First, let's start by learning how to set a personal access code:

- 1** Press the **MENU** button on the remote to display the on-screen menu.
- 2** Press the **CURSOR UP**  $\wedge$  or **DOWN**  $\vee$  button until the word **FEATURES** is highlighted.
- 3** Press the **CURSOR RIGHT**  $\>$  button to display the **FEATURES** menu options.
- 4** Press the **CURSOR UP**  $\wedge$  or **DOWN**  $\vee$  button until the words **AUTOLOCK™** are highlighted.
- 5** Press the **CURSOR RIGHT**  $\>$  button. The screen will read, "ACCESS CODE - - - -."
- 6** Using the **NUMBERED** buttons, enter **0, 7, 1, 1**. "XXXX" appears on the Access Code screen as you press the numbered buttons.  
 "INCORRECT CODE" will appear on the screen, and you will need to enter **0, 7, 1, 1** again.
- 7** The screen will ask you to enter a "New Code." Enter a "new" 4 digit code using the **NUMBERED** buttons. The screen will then ask you to **CONFIRM** the code you just entered. Enter your new code again.  
 "XXXX" will appear when you enter your new code and then display the AutoLock™ menu options.

Proceed to the next panel to learn more...

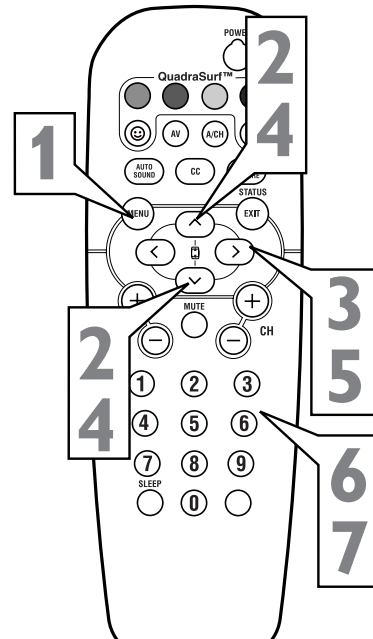
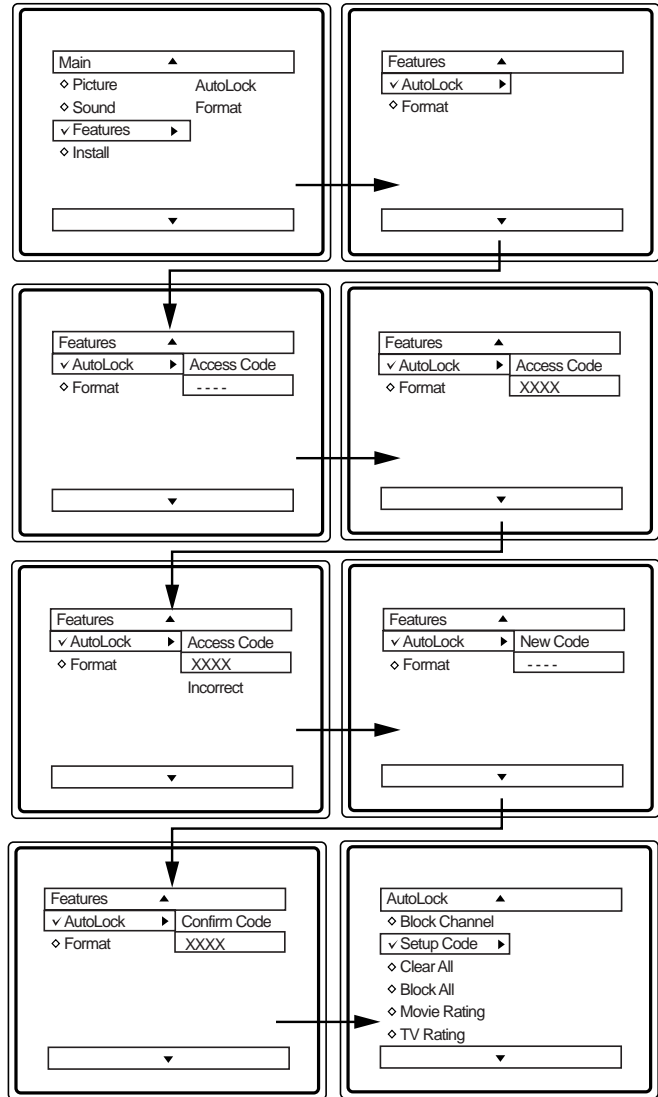

# 19

## How to BLOCK CHANNELS WITH AUTOLOCK™

After your personal access code has been set (see previous page), you are now ready to select the channels or the A/V Inputs you want to block out or censor. Once you've entered your access code and the AutoLock™ features are displayed on the screen:

- 1** Press the **CURSOR UP**  $\wedge$  or **DOWN**  $\vee$  buttons until the words **BLOCK CHANNELS** are highlighted.
- 2** Press the **CURSOR RIGHT**  $\>$  button to turn blocking ON or OFF for that channel. When ON is selected the channel will be blocked.
- 3** Press the **CH +** or **CH -** button to select other channels you wish to block. Repeat step 9 to block the new channel.
- 4** When finished, press the **STATUS/EXIT** button to remove the menu from the screen.

**NOTE:** If you ever forget your code, the 0, 7, 1, 1 code is the factory default and can be used to enter and create a new access code.

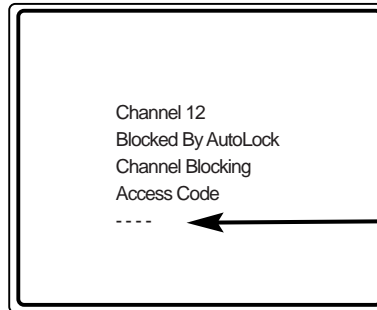
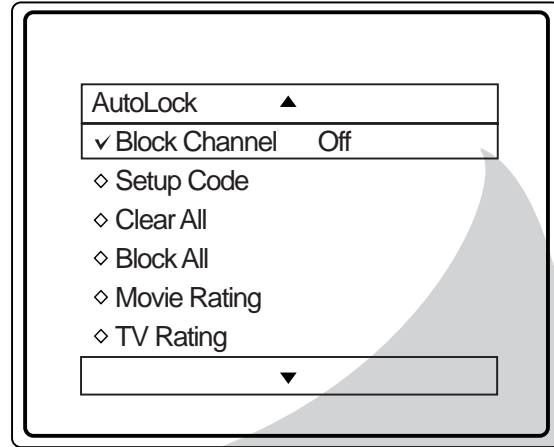

Enter your Access Code to view a tuned channel that is blocked with Block Channel.

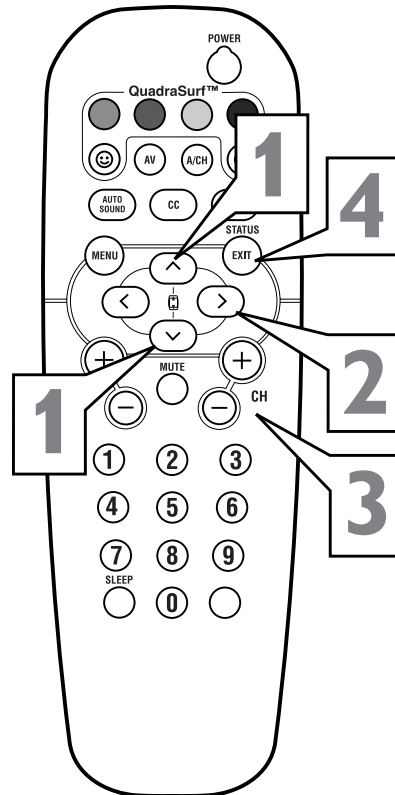

# 20 BLOCKING OR CLEARING ALL CHANNELS AT THE SAME TIME

After blocking specific channels there may come a time when you want to block or clear all the channels at the same time.

Once you've entered your access code and the AutoLock™ features are displayed on the screen:

**1** Press the **CURSOR UP**  $\wedge$  or **DOWN**  $\vee$  buttons to select either **CLEAR ALL** or **BLOCK ALL**.

**2** If **CLEAR ALL** is selected, press the **CURSOR RIGHT**  $\>$  button to clear all blocked channels. All channels will be viewable.

If **BLOCK ALL** is selected, press the **CURSOR RIGHT**  $\>$  button to turn the control ON or OFF.

When ON is selected, ALL available channels will be blocked from viewing.

**3** When finished, press the **STATUS/EXIT** button to remove the menu from the screen.

**NOTE:** If you ever forget your code, the 0, 7, 1, 1 code is the factory default and can be used to enter and create a new access code.

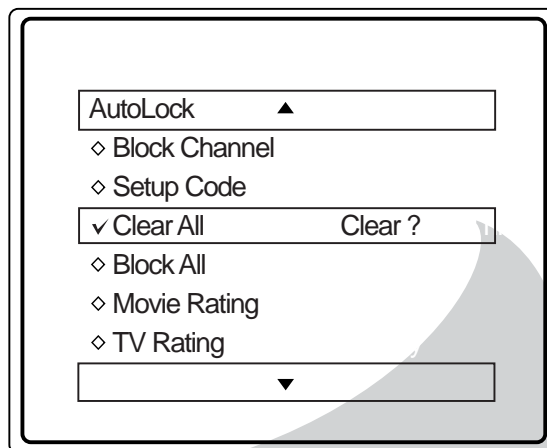

**✓ Clear All**      Cleared

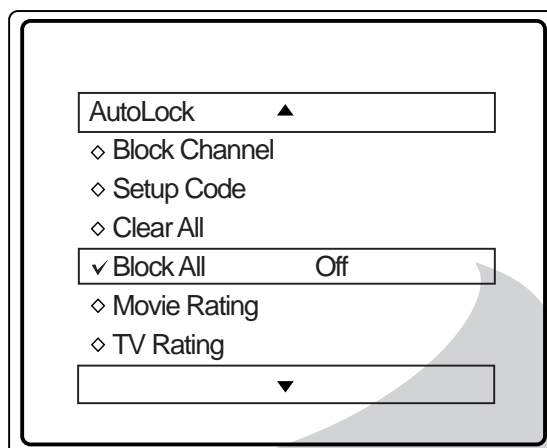

**✓ Block All**      On

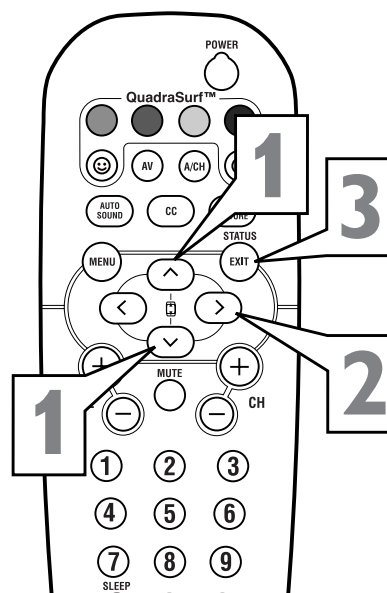



# 21

## BLOCK PROGRAMS BASED ON MOVIE RATINGS

The AutoLock™ feature can block programming based on the Movie Industry ratings.

Once you've entered your access code and the AutoLock™ features are displayed on the screen:

- 1 Press the CURSOR UP  $\wedge$  or DOWN  $\vee$  button** to highlight the words MOVIE RATING.
- 2 Press the CURSOR RIGHT  $\>$  button** to display the MOVIE RATING options (G, PG, PG-13, R, NC17, or X).
- 3 Press the CURSOR UP  $\wedge$  or DOWN  $\vee$  button** to highlight any of the Movie Rating options. When highlighted, all these options can be turned ON (which will allow blocking) or OFF (which will allow viewing).
- 4 Use the CURSOR RIGHT  $\>$  button** on the remote to turn the rating option ON or OFF.

When a rating level is chosen to be blocked, any higher level rating will also be blocked from viewing. (i.e.: If "R" is selected to be blocked, NC-17 and X will automatically be blocked.)

**NOTE:** If you ever forget your code, the 0, 7, 1, 1 code is the factory default and can be used to enter and create a new access code.

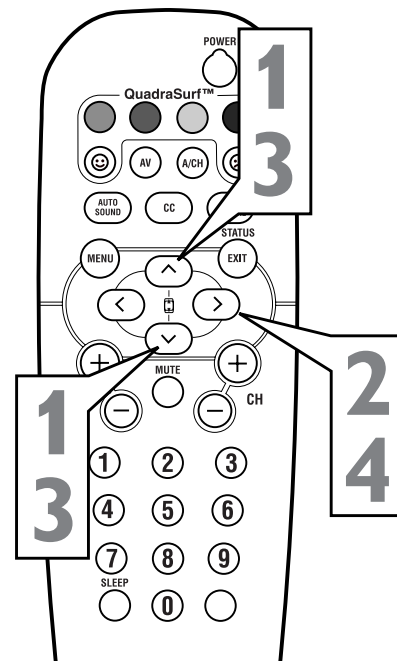
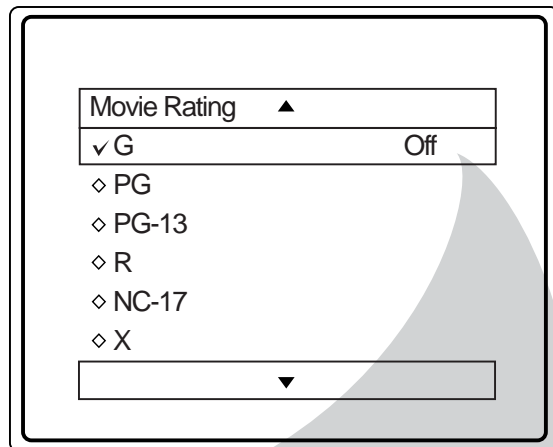
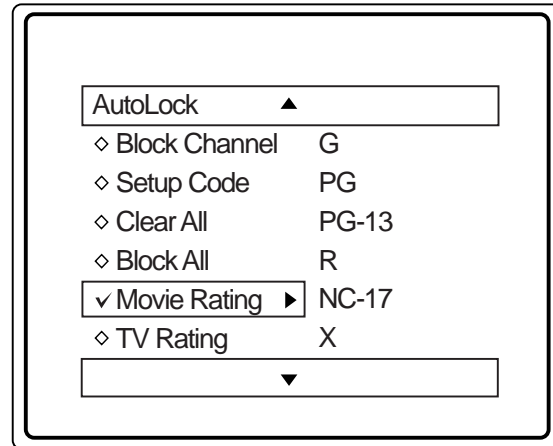

The AutoLock™ feature can block programming based on the TV Industry ratings.

Once you've entered your access code and the AutoLock™ features are displayed on the screen:

**1** Press the **CURSOR UP**  $\wedge$  or **DOWN**  $\vee$  button to highlight the words TV RATING.

**2** Press the **CURSOR RIGHT**  $\>$  button to display the **TV RATING** options (TV-Y, TV-Y7, TV-G, TV-PG, TV-14, or TV-MA).

**3** Press the **CURSOR UP**  $\wedge$  or **DOWN**  $\vee$  button to highlight any of the TV Rating options. When highlighted, all these options can be turned **ON** (which will allow blocking) or **OFF** (which will allow viewing).

**NOTE:** Some TV RATING options also have sub-ratings. The ratings of TV-Y7, TV-PG, TV-14, TV-MA can be customized to block V (violence), FV (fantasy violence), S (sexual situations), L (coarse language), or D (suggestive dialogue).

**4** Press the **CURSOR RIGHT**  $\>$  button on the remote to turn the TV-Y or TV-G rating ON or OFF. Or, press the **CURSOR RIGHT**  $\>$  button to enter the sub-menus for the TV-Y7, TV-PG, TV-14 or TV-MA ratings.

**5** If the TV-Y7, TV-PG, TV-14 or TV-MA sub-menu is accessed, press the **CURSOR UP**  $\wedge$  or **CURSOR DOWN**  $\vee$  button to select one of the options (Block All, V, S, L, D, or FV).

**6** Press the **CURSOR RIGHT**  $\>$  button on the remote to turn the option ON or OFF.

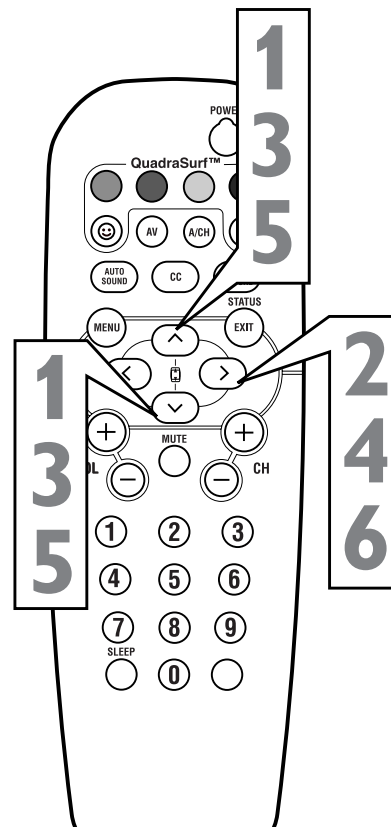
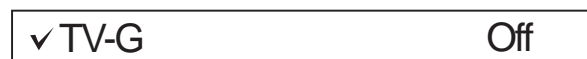
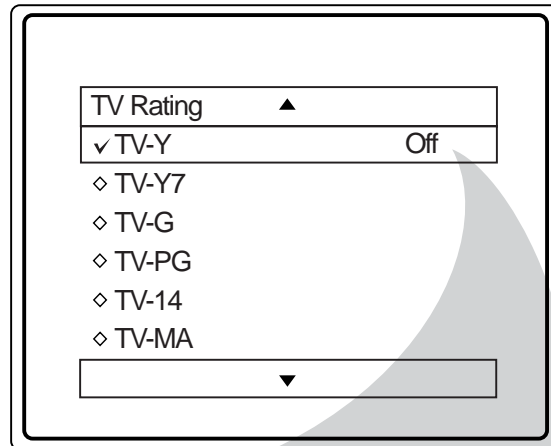

**A**utoLock™ offers the viewer other blocking features as well. With these Blocking Options, the censoring can be turned ON or OFF.

Once you've entered your access code and the AutoLock™ features are displayed on the screen:

**1** Press the **CURSOR UP**  $\wedge$  or **DOWN**  $\vee$  buttons until the words **BLOCKING OPTIONS** are highlighted.

**2** Press the **CURSOR RIGHT**  $\>$  button to display the **Blocking Options (BLOCKING, UNRATED, or NO RATING)** menu.

**BLOCKING:** Might be called the “master switch” for AutoLock™. When ON, ALL blocking/censoring will take place. When OFF, ALL blocking is disabled.

**UNRATED:** ALL unrated programs based on the Movie Ratings or Parental (TV) Guidelines can be blocked if this feature is set to ON and the **BLOCKING** feature is set to OFF.

**NO RATING:** ALL programming with NO content advisory data can be blocked if set to ON and the **BLOCKING** feature is set to OFF.

**3** Press the **CURSOR UP**  $\wedge$  or **DOWN**  $\vee$  buttons to highlight the desired feature.

**4** When highlighted, each feature can be turned **ON** or **OFF** using the **CURSOR RIGHT**  $\>$  or **LEFT**  $\<$  buttons on the remote.

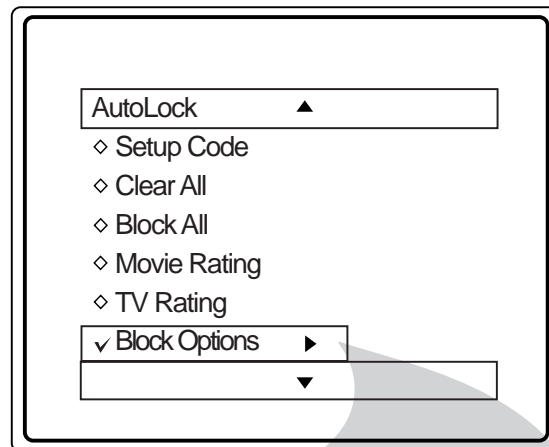

✓ Blocking	On
✓ Unrated	On
✓ No Rating	On

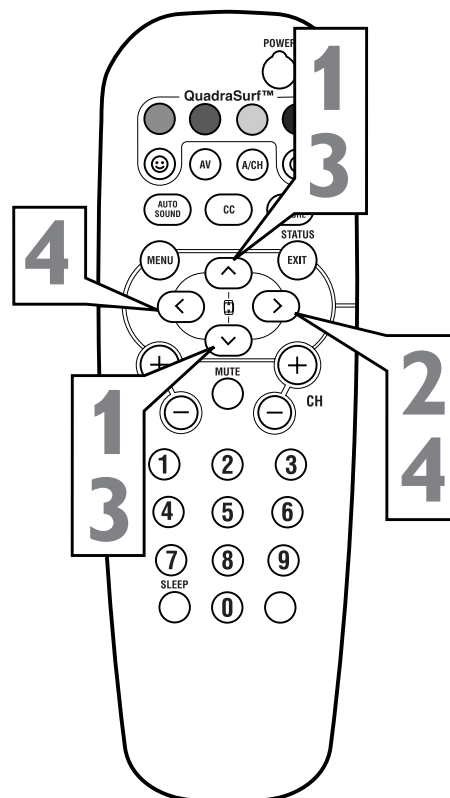

# 24

## USING THE CLOSED CAPTION CONTROL

**C**losed Captioning (CC) allows you to read the voice content of television programs on the TV screen. Designed to help the hearing impaired, this feature uses on-screen “text boxes” to show dialogue and conversations while the TV program is in progress.

- 1 Press the CC button** on the remote to display the current Closed Caption setting.
- 2 Press the CC button repeatedly** to choose from the four Closed Caption options (CC Off, CC1, CC2, CC Mute).
- 3 When finished, press the STATUS /EXIT button** to remove the menu from the TV’s screen.

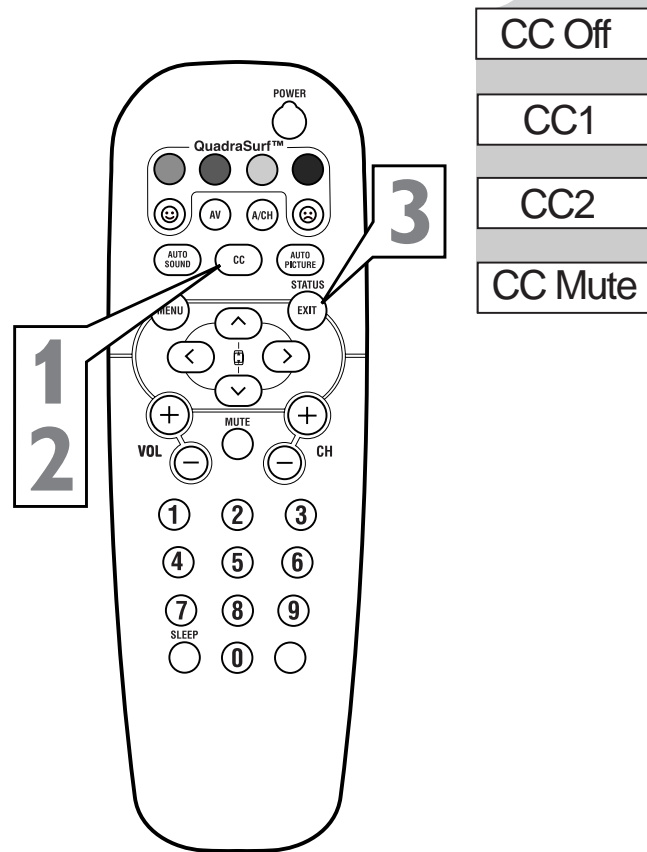
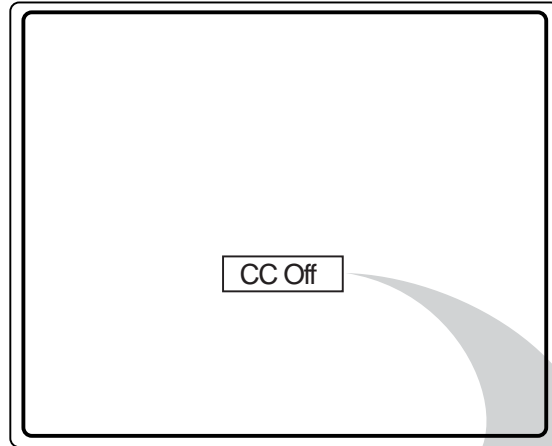

Your TV can be set to automatically turn itself off at a given amount of time.

- 1 Press the SLEEP button** on the remote control and the SLEEP timer display will appear on the screen.
- 2 Press the SLEEP button repeatedly** to pick the amount of time (15, 30, 45, 60, 90, 120, 180, or 240 minutes) before the TV will turn itself off.

**NOTE:** An on-screen count down will appear during the last minute before the TV shuts itself off. If any button is pressed during the last minute of the countdown, the Sleptimer setting will be cancelled.

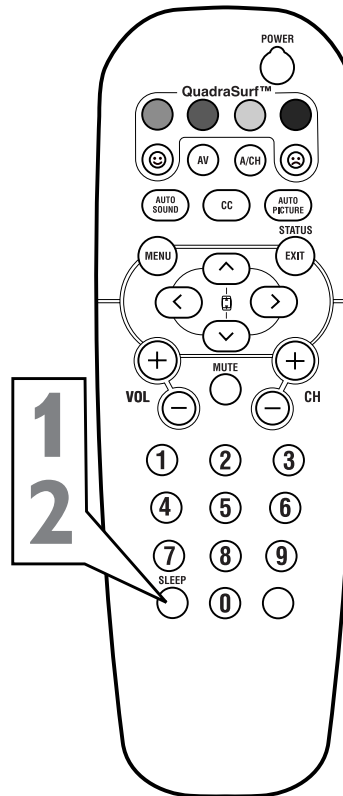
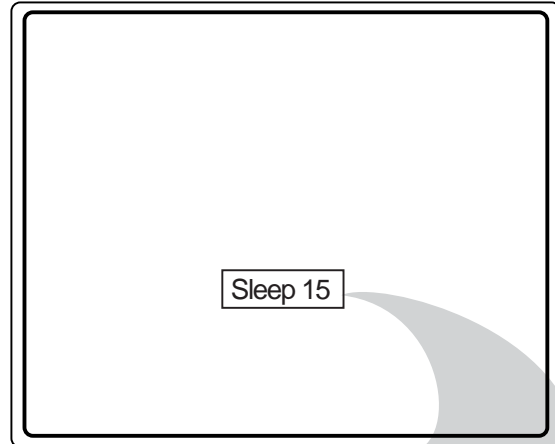

- Sleep 15
- Sleep 30
- Sleep 45
- Sleep 60
- Sleep 90
- Sleep 120
- Sleep 180
- Sleep 240
- Sleep off

Whether you're watching a movie or a sporting event, your TV has automatic video control settings matched for your current program source or content.

**1** Press the **AUTO PICTURE** button on the remote control. The current Auto Picture setting will be displayed on the screen.

**2** Press the **AUTO PICTURE** button repeatedly to select either **PERSONAL**, **MOVIES**, **SPORTS**, **WEAK SIGNAL**, or **MULTIMEDIA** picture settings.

**NOTE:** The way you choose to set the Picture Menu Controls will become your **PERSONAL** setting.

**MOVIES** - Preset picture options for watching Video Tapes, or DVDs.

**SPORTS** - Preset picture options for watching sporting events.

**WEAK SIGNAL** - Preset picture options for watching programs where the reception is not at its best.

**MULTIMEDIA** - Preset picture options for use with video gaming.

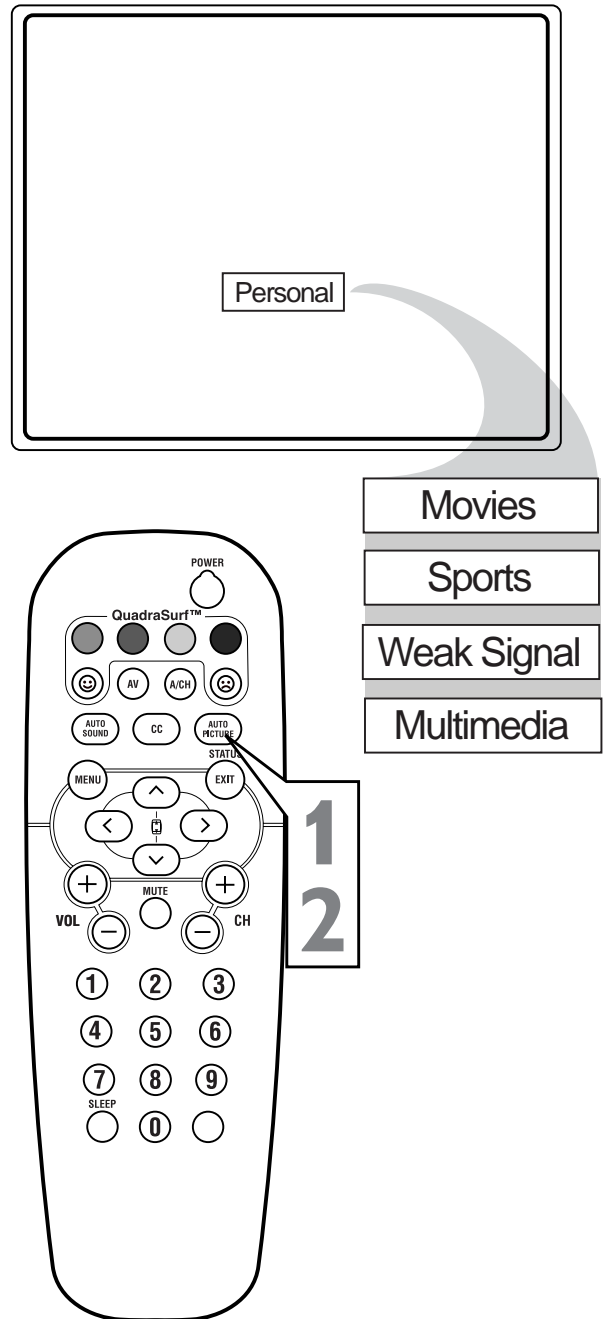

The Auto Sound feature allows the listener to select between four different factory set sound options.

**1** Press the **AUTO SOUND** button on the remote control. The current Auto Sound setting will appear in the middle of the screen.

**2** Press the **AUTO SOUND** button repeatedly to toggle between the four settings. (PERSONAL, THEATRE, MUSIC, or VOICE)

**NOTE:** The way you choose to set the Sound Menu Controls will become your PERSONAL setting.

**THEATRE** - Preset sound options for watching movies.

**MUSIC** - Preset sound options for musical programming where there is little dialogue.

**VOICE** - Preset sound options for programming where heavy dialogue is present.

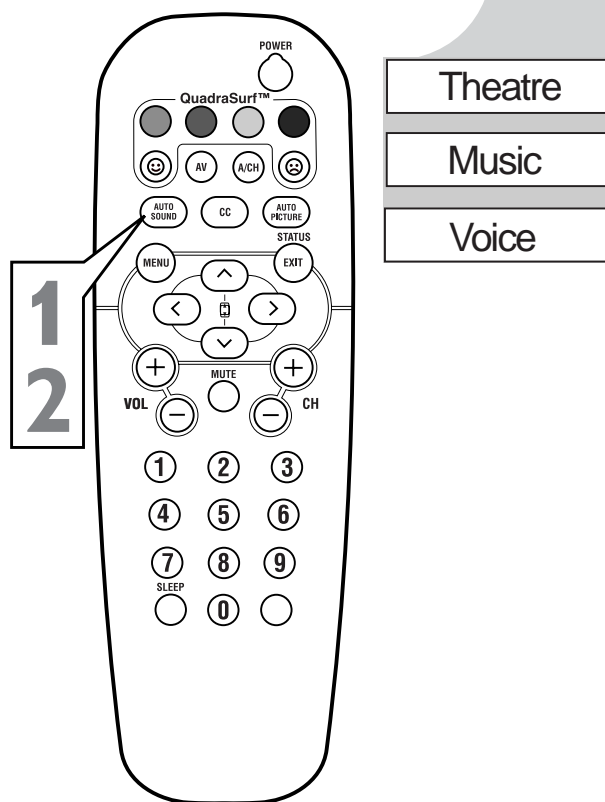
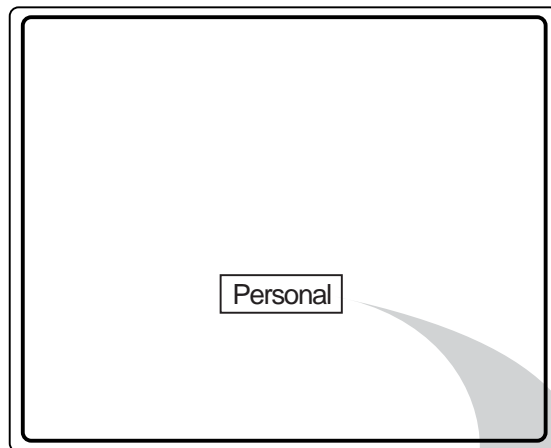

The QuadraSurf™ control allows you set up four different personal channel Surf lists using the colored buttons (on the remote control), each holding up to ten channels in its quick viewing “list.”

- 1** Press the CHANNEL (+) or (–) buttons (or the NUMBER buttons) to select a channel to add to one of the SURF lists.
- 2** Press the SMILEY 😊 button on the remote control to ADD the channel to one of the SURF lists.
- 3** Press the corresponding COLORED (Red, Green, Yellow or Blue) button to add the channel to that button’s Surf list. (Up to ten channels per button can be stored.)

Repeat steps 1 through 3 to add additional channels (up to 10) to each of the the SURF lists.

**To remove a channel from one of the SURF lists;**

- 4** Press the COLORED Quadra Surf button until the desired channel appears. The screen will display the channel number with a colored “Smiley” face to indicate the Colored button it relates to.
- 5** While the “Smiley” face channel indicator is displayed, press the FROWNIE ☹️ face button. The screen will read, “Remove item? - Press ☹️ .”
- 6** Press the FROWNIE ☹️ face button again to confirm your decision to remove the channel from the Surf list.

Repeat steps 4-6 to remove other channels from Surf lists.

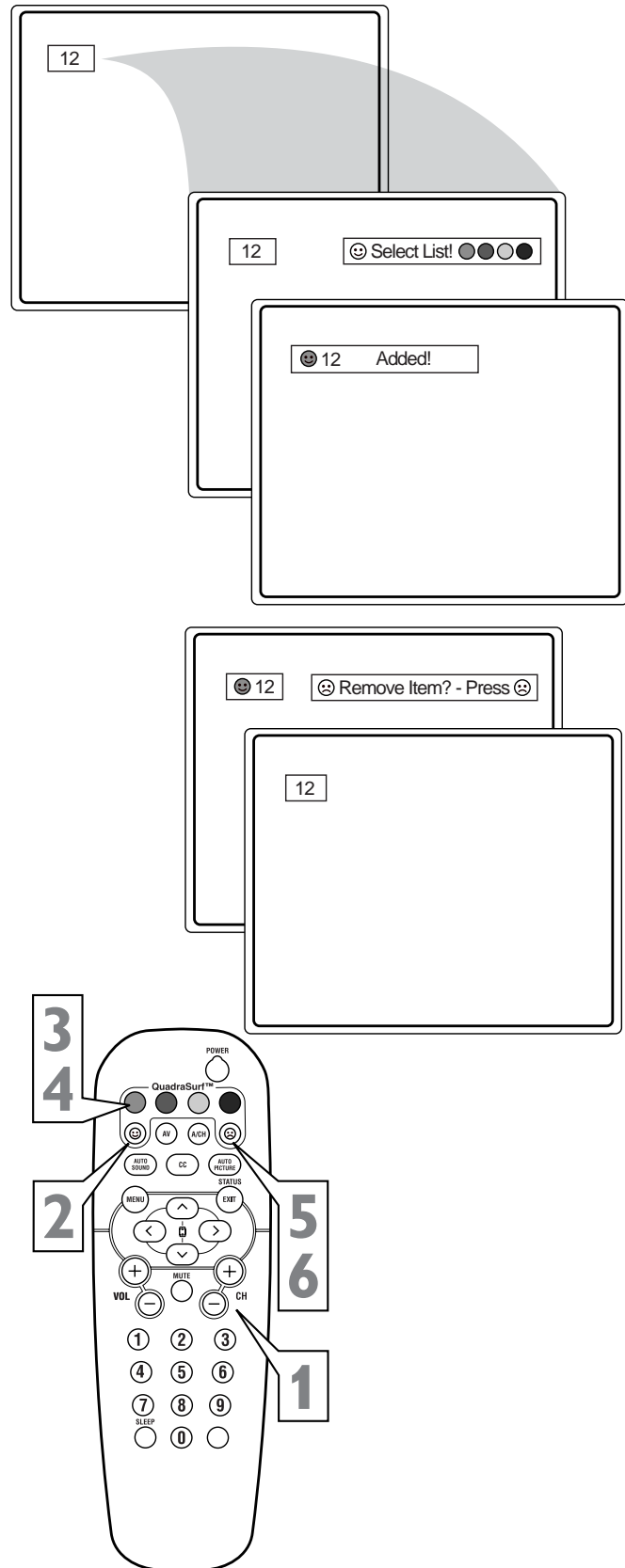



The QuadraSurf™ buttons on your remote control allow you to store up to 10 channels per button (40 total). This is a great feature if you want to store all your favorite Sports channels, Movie channels, or News channels in one surf list. Family members can have their own favorite list of channels. You can even program the external A/V Input jacks (Front channel) for one of the buttons making it a “source” button for your external accessory devices.

Assuming channels have now been added to the four Quadra Surf lists (the four colored buttons, see the previous page), let's review how the feature works.

- 1** Press one of the pre-programmed **COLORED** buttons on the remote (Red, Green, Yellow or Blue). The screen will display a smiley face with the first programmed channel for that surf list.
- 2** While the colored “smiley” face still appears on the screen, press the same **COLORED** button on the remote to tune the second channel programmed for that specific surf list.
- 3** Repeatedly pressing the same **COLORED** button while the “smiley” face appears will tune all the programmed channels. Pressing the **COLORED** button again will return you to the first channel in the list.

If the “smiley” face disappears from the screen and the same **COLORED** button is pressed, the surf channels will be displayed starting with the **FIRST** programmed channel again.

- 4** Repeat steps 1-3 for the other three **COLORED** buttons (Surf lists) if desired.
- 5** Any time the “smiley” face appears with the channel number, **pressing the “frownie” face button** will allow you to remove it from the list (see the previous page for more details).

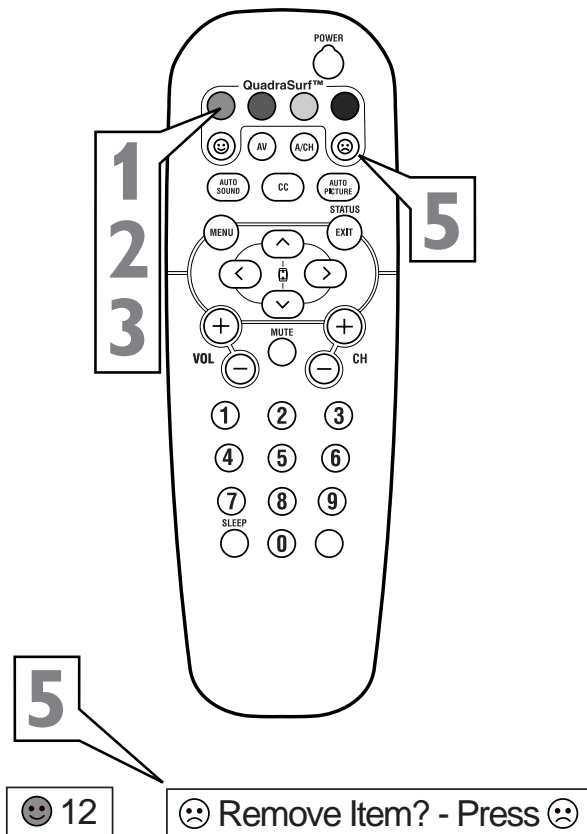
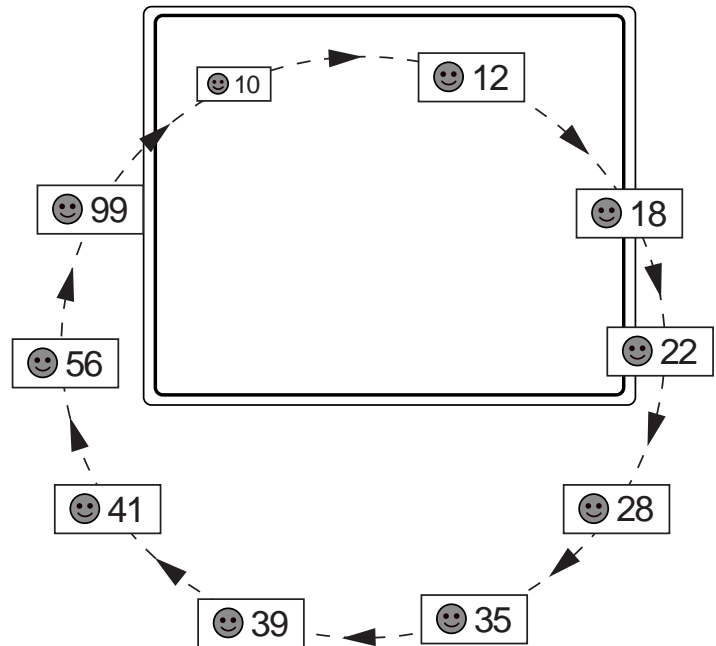

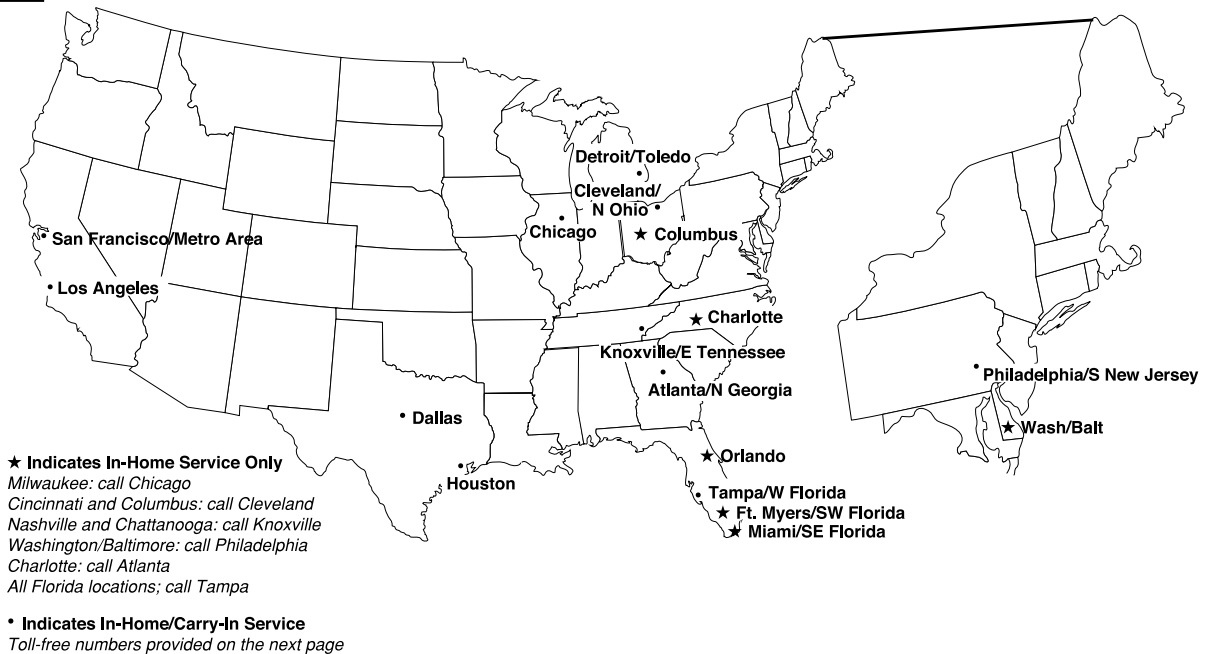

**NOTE:** If you reside in one of our Philips Factory Service Branch areas (see directory on back), you can contact the nearest Service Branch to obtain efficient and expedient repair for your product. If your product is In-Warranty, you should have proof-of-purchase to ensure No Charge Service. For Out-of-Warranty service, call the location nearest you.

**NOTA:** Si vous résidez dans une des régions desservies par une succursale de service après vente du fabricant Philips (voir liste ci-dessous), vous pourrez contacter la branche de service après vente la plus près de chez vous pour obtenir un service après vente rapide et efficace. Si le produit est sous garantie, il suffira de présenter une preuve d'achat pour bénéficier d'un service sans frais. Pour les produits non couverts par la garantie, contactez le centre le plus près de chez vous.

**NOTA:** Si Ud. reside en una de nuestras zonas para sucursales Philips de servicio al de fábrica (ver directorio más abajo), Ud. puede comunicarse con la sucursal de servicio más cercana para obtener una reparación oportuna y eficaz de su producto. Si su producto está todavía bajo garantía, Ud. debe presentar comprobante de compra para no ocasionar ningunos cargos por servicio. Para servicio después del vencimiento de la garantía, llame al lugar más cercano de los abajo indicados.

**In Canada:** How you can obtain efficient and expedient carry-in, mail-in, or in-home service for your product. Please contact Philips at: 1-800-661-6162 (French speaking)  
 1-800-363-7278 (English or Spanish speaking)

**Au Canada:** Comment obtenir le service après-vente pour les produits apportés ou envoyés par la poste à notre centre de service ou le service à domicile.  
 Veuillez contacter philips à: 1-800-661-6162 (Francophone)  
 1-800-363-7278 (Anglais ou Espagnol)

**En el Canadá:** Cómo recibir servicio eficiente para su producto, en persona, por correo o a domicilio. Favor de comunicarse con Philips al: 1-800-661-6162 (francófono)  
 1-800-363-7278 (Inglés o Español)

**QUALITY SERVICE IS AS CLOSE AS YOUR TELEPHONE! SIMPLY LOOK OVER THE LIST BELOW FOR THE NUMBER OF A FACTORY SERVICE CENTER NEAR YOU. YOUR PRODUCT WILL RECEIVE EFFICIENT AND EXPEDIENT CARRY-IN, MAIL-IN, OR IN-HOME SERVICE, AND YOU WILL RECEIVE PEACE OF MIND, KNOWING YOUR PRODUCT IS BEING GIVEN THE EXPERT ATTENTION OF PHILIPS' FACTORY SERVICE.**

COMMENT OBTENIR NOTRE SERVICE APRÈS VENTE RAPIDE ET EFFICACE SOIT PAR COURRIER, À DOMICILE, OU EN SE PRÉSENTANT À UN CENTRE DE SERVICE PHILIPS. PLUS DE 600 CENTRES DE RÉCEPTION DE PRODUITS À RÉPARER À TRAVERS LE PAYS: CONTACTER LE CENTRE DE SERVICE AUX CONSOMMATEURS LE PLUS PROCHE POUR SAVOIR L'EMPLACEMENT DE CES DÉPÔTS DANS UN RAYON DE 50 À 75 MILES (80 KM À 120 KM) DU CENTRE DE SERVICE LOCAL.

CÓMO OBTENER UN SERVICIO OPORTUNO Y EFICIENTE POR CORREO, EN CASA O EN PERSONA PARA SU PRODUCTO A TRAVÉS DE UN CENTRO PHILIPS DE SERVICIO. MAS DE 600 SITIOS POR TODO EL PAIS PARA LA RECEPCION DE PRODUCTOS NECESITADOS DE REPARACIONES: COMUNICARSE CON EL CENTRO DE SERVICIO DE FABRICA MAS CERCANO PARA ESTOS LUGARES DENTRO DE UN RADIO DE 80 A 120 KM (50 A 75 MILLAS) DEL CENTRO DE SERVICIO LOCAL.

**ATLANTA**

Philips Factory Service  
550 Franklin Road.,  
Suite F  
Marietta, GA 30067  
800-273-1501

**TAMPA**

Philips Factory Service  
1911 US Highway 301  
North, Suite 100  
Tampa, FL 33619  
800-442-2027

**SAN FRANCISCO**

Philips Factory Service  
681 East Brokaw Rd.  
San Jose, CA 95112  
800-300-9013

**HOUSTON**

Philips Factory Service  
1110 N. Post Oak Rd.,  
Suite 100  
Houston, TX 77055  
800-952-3254

**CLEVELAND**

Philips Factory Service  
950 Keynote Circle  
Brooklyn Heights, OH  
44131  
800-331-7037

**DETROIT**

Philips Factory Service  
25173 Dequindre  
Madison Heights, MI  
48071  
800-438-1398

**DALLAS**

Philips Factory Service  
415 N. Main Street,  
#107  
Euless, TX 76040  
800-952-3254

**CHICAGO**

Philips Factory Service  
1279 W. Hamilton Pkwy.  
Itasca, IL 60143  
800-531-2922

**KNOXVILLE**

Philips Factory Service  
One Philips Drive  
Knoxville, TN 37914  
800-821-1767

**PHILADELPHIA**

Philips Factory Service  
352 Dunks Ferry Rd.  
Bensalem, PA 19020  
800-847-9320

**LOS ANGELES**

Philips Factory Service  
20930 Bonita, Ste. V  
Carson, CA 90746  
800-300-9013

**COLOR TELEVISION** - 90 Days Free Labor, One Year Free Replacement of Parts (Two Years Free Replacement on Color Picture Tube) Must be carried in for service.

### WHO IS COVERED?

You must have proof of purchase to receive warranty service. A sales receipt or other document showing that you purchased the product is considered proof of purchase.

### WHAT IS COVERED?

Warranty coverage begins the day you buy your product. For 90 days thereafter, all parts will be repaired or replaced free, and labor is free. From 90 days to one year from the day of purchase, all parts will be repaired or replaced free, but you pay for all labor charges. From one to two years from the day of purchase, you pay for the replacement or repair of all parts except the picture tube, and for all labor charges. After two years from the day of purchase, you pay for the replacement or repair of all parts, and for all labor charges.

All parts, including repaired and replaced parts, are covered only for the original warranty period. When the warranty on the product expires, the warranty on all replaced and repaired parts also expires.

### WHAT IS EXCLUDED?

Your warranty does not cover:

- labor charges for installation or setup of the product, adjustment of customer controls on the product, and installation or repair of antenna systems outside of the product.
- product repair and/or part replacement because of misuse, accident, unauthorized repair or other cause not within the control of Philips Consumer Electronics Company.
- reception problems caused by signal conditions or cable or antenna systems outside the unit.
- a product that requires modification or adaptation to enable it to operate in any country other than the country for which it was designed, manufactured, approved and/or authorized, or repair of products damaged by these modifications.
- incidental or consequential damages resulting from the product. (Some states do not allow the exclusion of incidental or consequential damages, so the above exclusion may not apply to you. This includes, but is not limited to, prerecorded material, whether copyrighted or not copyrighted.)
- a product used for commercial or institutional purposes.

### WHERE IS SERVICE AVAILABLE?

Warranty service is available in all countries where the product is officially distributed by Philips Consumer Electronics Company. In countries where

Philips Consumer Electronics Company does not distribute the product, the local Philips service organization will attempt to provide service (although there may be a delay if the appropriate spare parts and technical manual(s) are not readily available).

### MAKE SURE YOU KEEP..

Please keep your sales receipt or other document showing proof of purchase. Attach it to this owner's manual and keep both nearby. Also keep the original box and packing material in case you need to return your product.

### BEFORE REQUESTING SERVICE...

Please check your owner's manual before requesting service. Adjustments of the controls discussed there may save you a service call.

### TO GET WARRANTY SERVICE IN U.S.A., PUERTO RICO OR U.S. VIRGIN ISLANDS...

Contact a Philips factory service center (see enclosed list) or authorized service center to arrange repair.

(In U.S.A., Puerto Rico and U.S. Virgin Islands, all implied warranties, including implied warranties of merchantability and fitness for a particular purpose, are limited in duration to the duration of this express warranty. But, because some states do not allow limitations on how long an implied warranty may last, this limitation may not apply to you.)

### WARRANTY COVERAGE IN CANADA...

Note: Product Warranty coverage may vary between countries where product is distributed by Philips Consumer Electronics Company. In order to receive full and specific warranty details for products sold and serviced in Canada, please contact Philips at:

**1-800-661-6162** (French Speaking)

**1-800-531-0039** (English and Spanish Speaking)

### REMEMBER...

Please record the model and serial numbers found on the product below. Also, please fill out and mail your warranty registration card promptly. It will be easier for us to notify you if necessary.

---

*This warranty gives you specific legal rights. You may have other rights which vary from state/province to state/province.*

---

**Philips, P.O. Box 520890**  
**Miami, FL 33152**  
**(402) 536-4171**