

PHILIPS



STV

MATCHLINE

287W960 A



PHILIPS



About this handbook

This is a handbook to help you with the installation and operation of your new menu TV.

With a menu TV, menus can be called up on the screen. These menus provide information either about operations to be carried out or about functions you can select.

This handbook consists of two parts :

Installation

This part helps you with installing your TV, selecting your menu language, locating and storing your TV channels and composing your favourite list of programme numbers. To do this, follow the directions of the **SYSTEM INSTALLATION** menu very closely. The installation menu is shown as it will appear on your screen.

SYSTEM INSTALLATION	
a	language
b	tv installation
c	photo CD/CDI
select : a-c menu off	

TV INSTALLATION	
a	channel installation
b	preselection preferences
select : a-b menu off	

Operation

After you have stored the TV channels, you can call them up on the screen. You can adjust the picture and sound via the main menu. The **MAIN MENU** is shown here as it will appear on the screen. Feel free to try out all the different possibilities of your TV. Use this part of the handbook to help you doing this.

MAIN MENU 1	
a	picture
b	sound
c	programme list
d	special features
e	>>>>
select : a-e menu off	

MAIN MENU 2	
a	recording source
b	system installation
c	>>>>
select : a-c menu off	

- This circle in front of a sentence indicates that you have to **do** something.
- ▷ This arrow in front of a sentence indicates the **result** of what you have done.

In the stripe under each menu you are told which keys you can press and how you can switch the menus off again.

Contents

Installation

Preparation	2
Switching TV on	3
Selecting your Menu language	4
Searching for and Storing TV channels	5

Operation

Operation	10
Main Menu	11
Other Functions	16
Pip Picture in Picture	20
Teletext	22
Peripheral Equipment	25
Tips	32

1 Preparation

Place the TV on a solid surface.
For ventilation, leave a space of at least 5 cm free all around the set.

This TV requires a mains voltage of 220 V - 240 V.

Insert the aerial plug tightly into the aerial socket  at the back of the TV with an aerial cable of good quality.
You can improve the picture quality by using the suppressor-aerial-cable supplied.

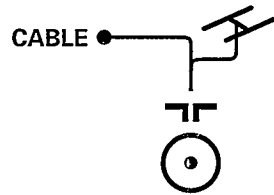

Insert the mains plug in the wall socket.

Remote control

This remote control has been developed to operate your TV.
However some main functions of your audio and video equipment from our product programme are controllable as well.

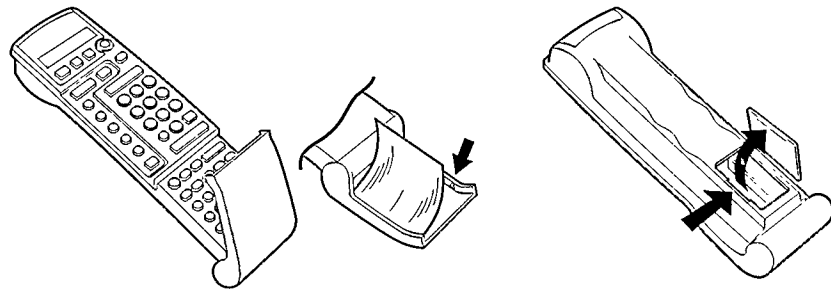

Rip off the label, written in your language from the label sheet, supplied with these instructions, click it onto the inside surface of the door of the remote control.
Remove the cover of the battery compartment on the back of the remote control.
Insert the 2 batteries supplied (type R03-1,5V).
Click the cover back into place.

- Press the TV key below the display.
- ▷ In the window of the remote control the letters TV appear in a grey block.

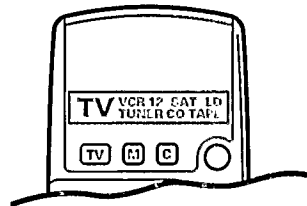

You can now operate your TV with your remote control.

Go on to 2.

2 Switching TV on

- Press the switch ① on the left side of your TV set.

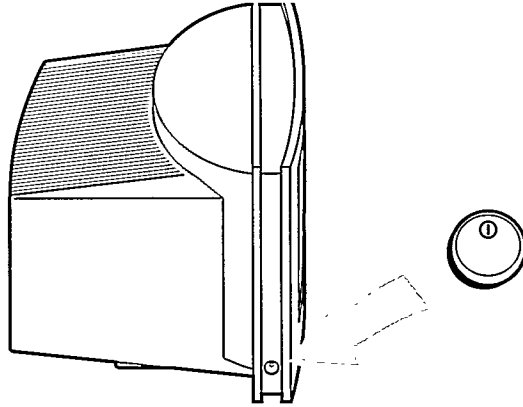

- ▷ A green or red lamp lights up on the front of your TV set.

green ①or

- ▷ The TV is switched on.
The screen lights up.

Go on to 3.

red ①

The TV is switched on but the screen stays dark. Your TV is on standby.

- Press a digit key on the remote control.
- ▷ The green lamp lights up and blinks every time you press a key on the remote control.
- ▷ The TV switches on.
The screen lights up.

Go on to 3.



Selecting your menu language

You can choose **for yourself** the language of the menus - the instructions and the various possible choices - which you call up on your screen.

- Press the **INSTALL** key on the right side of your TV set.

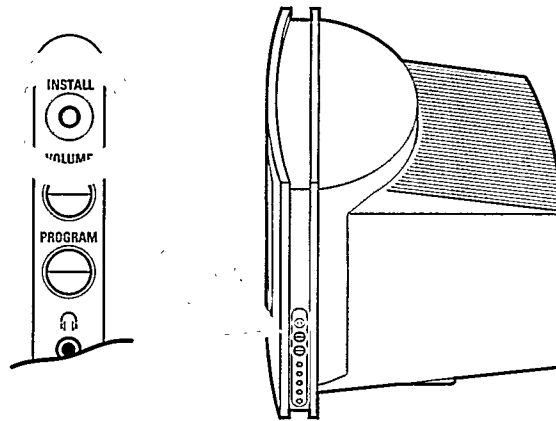

If the message **CHILD LOCK ON** appears, the child lock should be switched off. See **Special Features**, p. 14.

- ▷ The **SYSTEM INSTALLATION** menu appears on the screen.

*It is also possible to enter the installation menu via the main menu. See **Main Menu**, p. 11.*

SYSTEM INSTALLATION	
a	language
b	tv installation
c	photo CD/CDI
select a c menu off	

- Press the red key **a** on the remote control.
- ▷ The language menu appears on the screen.

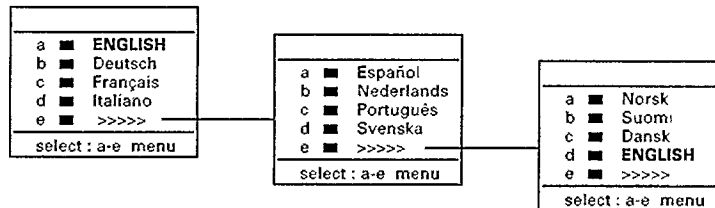

- Press the colour key of your language choice.
- Press the corresponding colour key for **>>>>** if the language you want does not appear on the first language menu.
- ▷ **LANGUAGE STORED** appears for a moment at the top of the menu. The language menu disappears and the **System Installation** menu appears again. From this point on, all menus are presented in the language of your choice.

Go on to 4.

Have you pressed the wrong key ?

*Press the red key **a** for language again and make a new choice.*

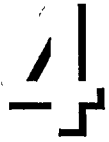

Searching for and storing TV channels

After you have switched on your TV and selected your menu language, you can search for and store your TV channels. Within the installation menu you yourself assign each of these TV channels a number and a name of your own choice, which are then used to call the channels up for viewing.

To expand conventional picture formats to wide screen picture formats, see Other Functions, Picture format, p.16.

- o Press the green key b.
- ▷ The TV INSTALLATION menu appears.

*Is the menu that appears not in your chosen language ?
Press the MENU key and go back to 3. Select your menu language.*

- o Press the red key a.
- ▷ The CHANNEL INSTALLATION menu appears.

Now follow very closely and **step by step** the instructions of the CHANNEL INSTALLATION menu. You must go through every step. Do this for every TV channel.

SYSTEM INSTALLATION	
a	language
b	tv installation
c	photo CD/CDI
select : a-c menu off	

TV INSTALLATION	
a	channel installation
b	preselection preferences
select : a-b menu off	

CHANNEL INSTALLATION	
step....	a system
step....	b search
step....	c programme
step....	d store
select : - + a-d 0-9 menu off	

step



Selecting the TV system

The television picture is not broadcast in the same way in all countries. We speak of different television systems (PAL, SECAM, NTSC,....) Now you must select the TV system **yourself**.

- o Press the red key a.
- ▷ The SELECTING THE SYSTEM menu appears.....
- 1 You have your own aerial.
 - o Press the colour key of the country or part of the world from where you want to select the TV channel.
 - ▷ The CHANNEL INSTALLATION menu now appears.
 - ▷ Your selection lights up.
- 2 You are connected to the cable system.
 - o Press the colour key of the country or part of the world where you now are located.
 - ▷ The CHANNEL INSTALLATION menu now appears.
 - ▷ Your selection lights up.

Or ONLY ONE SYSTEM AVAILABLE appears

You have a set that can receive only one system.
You do not need to make any selection.

Go on to step b.

Go on to step b.

If you have pressed the wrong key, then repeat step a.

step



Searching for a TV channel

This can be done in two different ways :
Either automatic searching or else entering a frequency yourself.

Automatic searching **Or** **Entering a frequency yourself**

The TV itself searches for the channel.

- Press the green key **b**.
- ▷ **SEARCHING** appears and the TV is searching for a channel.
- ▷ The frequency increases until a channel is found.

Go on to step **c** if you want to store the channel that has been found.

- Press  under the door of the remote control to recognise which programme is being broadcast.
- ▷ The **CHANNEL INSTALLATION** menu disappears temporarily.

Do you want a different channel or is the reception poor ?

- Press the green key **b** again.

Is the reception still poor ? See Tips, p. 32.

If no TV channel is found, interrupt the automatic searching by pressing any digit key. Check if you have selected the correct TV system or if the aerial is connected properly.

A TV channel is transmitted at a certain frequency.

If you know the frequency, you can enter it directly and in this way call up the TV channel.

Ask for a list of the frequencies at your cable company or at a dealer.

- First enter the 5 digits of the desired frequency.
- For frequencies under 100 MHz, first enter a 0. For example : 063.25.

*Have you entered a wrong number ?
First complete the frequency with arbitrary numbers and then start again.*

Fine-tuning

You may be able to improve the reception of picture and sound of a TV channel.

Adjust the frequency yourself with the **MENU - or +** key on the remote control.

Go on to step **c**.

step Entering the programme number and name

Now you **yourself** must assign a number of your choice and a name to the TV channel located. In this way you decide for yourself the order of all your TV channels.

With the assigned programme number you can call up your TV channel again later.

A name of maximum 5 letters or numbers can be given to the programme numbers 0 to 29. For example : SUPER, BBC1, ...

Thus you see immediately which TV channel you have stored under which programme number.

- Press the yellow key c.
- ▷ NAMING THE PROGRAMME appears.
- Press the red key a.
- Hold down the P - or + key on the remote control until the desired programme number appears in the menu.

In this list you can now enter the name of the TV channel.

With the arrow under the letter and number line you select which letter or which number in the list above you wish to enter.

In the list there is a red block next to the chosen programme number.

- Hold, as desired, either the green key b down to move the arrow to the left, or else the yellow key c to move the arrow to the right.
- ▷ The letter or number that you indicate with the arrow appears in the block.
- Press the blue key d.
- ▷ The block moves over one space.
Now you can choose a following letter or number with the arrow.
- Place the arrow between z and 0 for a space.

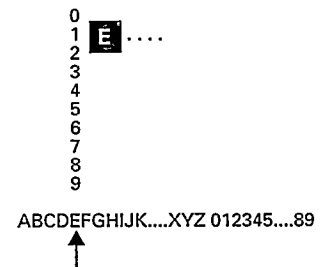

Did you fill in a wrong letter or number ?

Press repeatedly on the blue key d until the block is back in the place where you want to make a change.

Now choose with the arrow the correct letter or the correct number.

Is the complete name filled in ?

- Then press MENU.
- ▷ The CHANNEL INSTALLATION menu appears again.

Go on to step d.

step



Storing steps **a** to **c**

Now the TV system, the located TV channel, its programme number and its programme name must be stored in the memory.

- o Press the blue key **d**.
- ▷ **PROGRAMME STORED** appears briefly at the top of the menu.
- ▷ The TV channel is stored in the memory.

repeat

Do you want to store another TV channel ?

- o Repeat steps **a-b-c-d**.

Are you connected to the cable system ?

- o Begin immediately with step **b**. You have already selected the TV system in step **a** for all channels.

out

Do you want to exit the **CHANNEL INSTALLATION** menu or have you finished locating TV channels ?

- o Press **MENU**.
- ▷ The **TV INSTALLATION** menu appears.



Preselection Preferences

All the stored TV channels have been automatically placed into the programme list. In the **PRESELECTION PREFERENCES** menu you yourself should indicate for each stored TV channel if you want to keep that programme number as a favourite.

You can do this also for a programme number you want to reserve for the programmes you receive from your decoder.

This will make selecting your favourite TV channels a lot easier and faster.

TV INSTALLATION	
a	channel installation
b	preselection preferences
select a/b menu off	

PRESELECTION PREFERENCES	
a	programme number
b	favourite status
c	decoder
select a-c 0-9 menu off	



Favourite TV channels

- Press the green key b in the TV INSTALLATION menu.
- ▷ The PRESELECTION PREFERENCES menu appears.
- Press the red key a.
- ▷ PROGRAMME NUMBER lights up.
- Select the programme number of a TV channel with MENU - or + or with the digit keys.
- Press the green key b.
- ▷ FAVOURITE STATUS lights up.
- Press MENU - or + to select NO or YES.
In this way you decide whether you want to keep the selected TV channel as a favourite TV channel or not.
- Repeat this for each programme number.
- ▷ From now on when you run quickly through the TV channels by holding the P - or + key pressed down, only those TV channels which are in the favourite list will be displayed.
When you select a TV channel with the digit keys, the indication of the selected TV channel will be displayed in white characters when it is a TV channel from the favourite list, in red characters when it is a TV channel which is not in the favourite list.

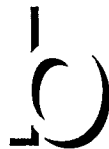

Decoder

- In case you have connected a decoder, see Decoders p. 28, you can define one or more programme numbers as a decoder preselection.
- Press the red key a in the PRESELECTION PREFERENCES menu.
 - ▷ PROGRAMME NUMBER lights up.
 - Select the programme number under which you want to store the programme coming from your decoder with MENU - or + or with the digit keys.
 - Press the yellow key c.
 - ▷ DECODER lights up.
 - Press MENU - or + repeatedly until the designation EXT1 or EXT2 appears according to the euroconnector to which you connected your decoder. Select NO if you do not want the selected programme number being activated as a decoder preselection.
 - Press MENU twice.
 - ▷ The SYSTEM INSTALLATION menu appears again.



Photo CD/CDI

- In case you have connected a photo Compact Disc or a Compact Disc
- Press the yellow key c in the SYSTEM INSTALLATION menu.
 - ▷ PHOTO CD/CDI lights up.
 - Press MENU + to select YES.
 - ▷ This offers you an optimum picture quality for your Photo CD or CDI.
 - Press off to exit the SYSTEM INSTALLATION menu.

Operation

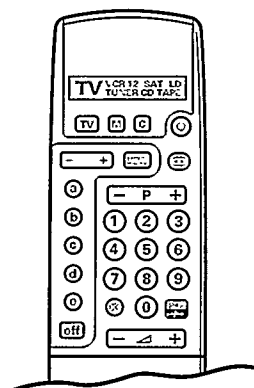

The letters **TV** in the display of the remote control must be in a grey block if you want to operate your TV.

If this is not the case, first press the **TV** key under the display.

Every time you press a key on the remote control, the green lamp ① on the front of your TV set blinks.

Switching TV on

- Press ① on the left side of your TV.
- ▷ A green lamp ① lights up. **PR1** appears briefly and possibly also the programme name.
- ▷ Does a red lamp ⏻ light up?
Your TV is on standby. Read on.

Standby

- With the standby key ⏻ at the top of the remote control you can temporarily switch the TV off.
- ▷ The lamp ⏻ on the TV lights up.
- Press the **C**-key in order to turn the TV on again.
If for a period of 10 minutes no aerial signal is received, then your set automatically switches to standby.
Switch off your TV overnight instead of leaving it on standby. You save energy and the picture tube is demagnetised which supports good picture quality.

Selecting TV channels

- Select the TV channel with the digit keys on the remote control.
- For a two-digit programme number, enter the second digit within 2 seconds.
- If you want to know which channel you are watching, open the door of the remote control and press **+** short.

Quickly run through the TV channels from the Favourite list.

- Hold the **P** - or + key pressed down.

Volume control

- Press **↙** - or +.

Temporarily interrupt the sound

- Press **⊗**.
- ▷ The sound is temporarily interrupted.
- Press **⊗** again to get the sound back.

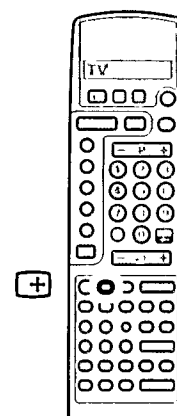

SOUND MUTED

Main Menu

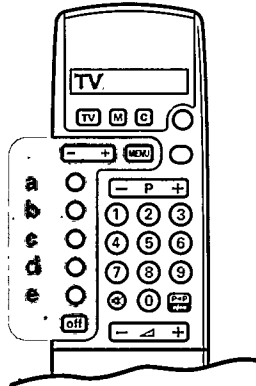

You use the keys in the grey area of the drawing to operate the main menu.

With the colour keys a-b-c-d-e you select your choice in the menus.

The main menu is split into 2 menus and you can:

- . adjust **picture** and **sound** according to personal preference
- . call up a **programme list** with an overview of the TV channels stored
- . select from among various **special features**
- . select **recording sources** for your video recorder
- . enter the **system installation** menu.

- o Press MENU.
- ▷ The MAIN MENU appears.
- o Press off to switch off each menu.

MAIN MENU 1	
a	picture
b	sound
c	programme list
d	special features
e	>>>>
select : a-e menu off	

MAIN MENU 2	
a	recording source
b	system installation
c	>>>>
select : a-c menu off	

Adjusting the picture

- o Press MENU.
- o Press the corresponding colour key for PICTURE.
- ▷ The PICTURE menu appears

- o Press one of the colour keys to select the adjustment you want to regulate.
When you have a set that can receive the NTSC system and when USA is selected in Selecting the TV system, see p. 5, also the option **tint** appears in the PICTURE 2 menu.
- ▷ The selected adjustment lights up.
- o Press MENU - or + in order to regulate the selected adjustment.
- o Press a colour key once more in order to select another adjustment.

PICTURE 1	
a	brightness
b	colour
c	contrast
d	sharpness
e	dig. scan
select : a-e menu off	

- o Do you want to store the changed adjustment in the memory ?
- o See Special Features, PP store, p. 14.

Digital scan (Line Flicker Reduction)

In certain circumstances while watching TV programmes it may be preferred to switch off the digital scan line flicker reduction.

- o Press the corresponding colour key for DIGITAL SCAN.
- o Press MENU - in order to switch off the line flicker reduction.

- o Press MENU.
- ▷ The MAIN MENU appears again.

Adjusting the sound

- Press MENU.
- Press the corresponding colour key for SOUND.
- ▷ The SOUND 1 menu appears.

Volume, balance, treble, bass

- Press one of the colour keys to select the adjustment you want to regulate.
- ▷ The selected adjustment lights up.
- Press MENU - or + in order to regulate the selected adjustment.
- Press a colour key again to select another adjustment.

Do you want to store the modified adjustment in the memory ?

- Press MENU.
- ▷ The MAIN MENU appears.
- See Special Features, PP store, p. 14.

Speech

- Press the white key e in the SOUND 1 menu.
- ▷ The SOUND 2 menu appears.
- Press the corresponding colour key for SPEECH.
- ▷ SPEECH lights up.
- Press MENU + to reveal the treble and to suppress the bass.
- Press MENU - to switch off.

Spatial and surround sound

- Press the corresponding colour key for SPATIAL in the SOUND 2 menu.
- ▷ SPATIAL lights up.
- Press MENU - or + to switch off or on.
- ▷ When SPATIAL ON is selected, it seems as though the loudspeakers are spread further apart from one another. You get a spatial sound effect.

You achieve a Surround Sound effect if you have 2 or for a maximum effect 4 extra loudspeakers connected. See Peripherals, p. 27.

In case of 2 extra loudspeakers, always connect them to REAR at the back of your TV.

In case of 4 extra loudspeakers, connect them to FRONT and REAR.

- Press the loudspeaker switch on the back of the TV out.
- ▷ The internal loudspeakers of your TV are now switched off.
- Place the loudspeakers in the corners of an imaginary square.

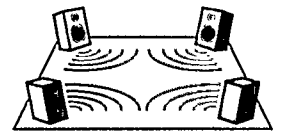

Mono broadcasting activates the two loudspeakers of your TV set or the two loudspeakers connected to FRONT.

- Select SPATIAL ON.
- ▷ You get a pseudo stereo effect.

Stereo broadcasting activates the two loudspeakers of your TV or the two loudspeakers connected to FRONT and the two loudspeakers connected to REAR.

- Select SPATIAL ON.
- ▷ You get a spatial stereo effect.

SOUND 1	
a	■ volume
b	■ balance
c	■ treble
d	■ bass
e	■ >>>>
select a-e menu off	

SOUND 2	
a	■ speech
b	■ spatial
c	■ sound mode
d	■ >>>>
select a-d menu off	

Sound mode

- Press the corresponding colour key for **SOUND MODE** in the **SOUND 2** menu.
- ▷ **SOUND MODE** lights up.
- ▷ If the TV channel which you are now watching transmits stereo or digital sound and if your set is equipped with Nicam, you can choose between :
 - . **stereo** or **mono** if the TV channel transmits *stereo* sound
 - . **digital** or **analogue** if the TV channel transmits *digital* sound.
- Select **analogue** or **mono** in case of weak digital or stereo sound signals.
- Press **MENU** - or +.

If you do not make a sound choice for the TV channel which you are watching your TV will choose between stereo or digital sound, depending on the sound the TV channel transmits.

- Press **MENU**.
- ▷ The **MAIN MENU 1** appears again.

Programme list

- Press **MENU**.
- Press the corresponding colour key for **PROGRAMME LIST**.
- ▷ A list with an overview of the stored TV channels appears.
 - TV channels from the favourite list are displayed in white characters.
 - TV channels which are not in the favourite list are displayed in red characters.
- Press **MENU**.
- ▷ The **MAIN MENU 1** appears again.

- Press **off**.
- ▷ The **MAIN MENU** disappears.

Special features

- Press MENU.
- Press the corresponding colour key for SPECIAL FEATURES.
- ▷ The SPECIAL FEATURES menu appears.
- Press a colour key in order to choose between child lock, sleeptimer, pp store, demonstration, pip size or picture format.
- ▷ Your choice lights up.
- Press once more on a colour key to make another choice.

SPECIAL FEATURES 1	
a	■ child lock
b	■ sleeptimer
c	■ pp store
d	■ demonstration
e	■ >>>>
select : a-e menu off	

SPECIAL FEATURES 2	
a	■ pip size
b	■ picture format
c	■ >>>>
select : a-c menu off	

Child lock

If the child lock is on, the TV can only be switched on with the digit keys on the remote control. The keys on the TV cannot be used.

- Press the corresponding colour key for CHILD LOCK.
- Press MENU - or + to switch the child lock off or on.

Sleeptimer

With the aid of the sleeptimer you can set the time when the TV should switch itself off.

- Press the corresponding colour key for SLEEPTIMER.
- Hold the key MENU + pressed down.
- ▷ The counter runs from off up to 90 minutes.
- Hold the key MENU - pressed down.
- ▷ The counter runs from 90 down to off.

If you have set a time, then one minute before the TV switches off the remaining minute automatically appears on the screen.

You can always switch off your set earlier.

Up to the last minute you can always change the time set.

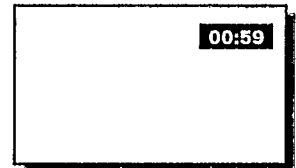

PP store

Adjustments made in the picture- and sound menu can be stored in the memory and be called up again with the PP key.

- Press the corresponding colour key for PP STORE.
- ▷ PP STORE lights up and PERSONAL PREFERENCE STORED appears briefly on the top of the menu.

At this point all previous adjustments are cancelled.

See also Other functions, p.17.

Demonstration

This function demonstrates one after another all the possible options of your TV.

- Press the corresponding colour key for DEMONSTRATION.
- Press MENU + to switch the demonstration on.
- Press off in order to stop the demonstration.

Pip size

You can select either a large or a small pip format.

- Press the corresponding colour key for PIP SIZE.
 - Press MENU - or +.
- For more information about Pip, see Pip, Picture in Picture, p. 20.

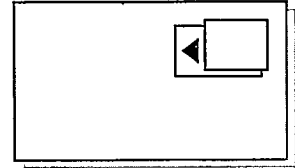

Picture format

A programme in the conventional picture format can be expanded so that you can take full advantage of your wide screen.

- Press the corresponding colour key for PICTURE FORMAT.
- Press MENU - or + repeatedly to select NORMAL, PANORAMA or EXPAND in order to choose between a conventional, a panoramic or a full expanded picture format.

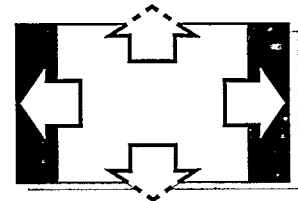
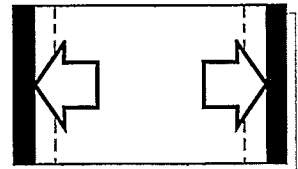

English

Recording Source

If you want to record a programme, then first read Peripherals, Recording, p. 31.

System Installation

You can also enter the System Installation menu via the Main Menu 2 to select your menu language and to locate and to store your TV channels.

- Press MENU.
- Press the corresponding colour key for SYSTEM INSTALLATION.
- ▷ The SYSTEM INSTALLATION menu appears on the screen.
- Now follow very closely and step by step the instructions as described on page 4 and following.

OFF

- Press MENU to leave the SYSTEM INSTALLATION menu.
- Press off to leave the SYSTEM INSTALLATION menu or the MAIN MENU.

Other functions

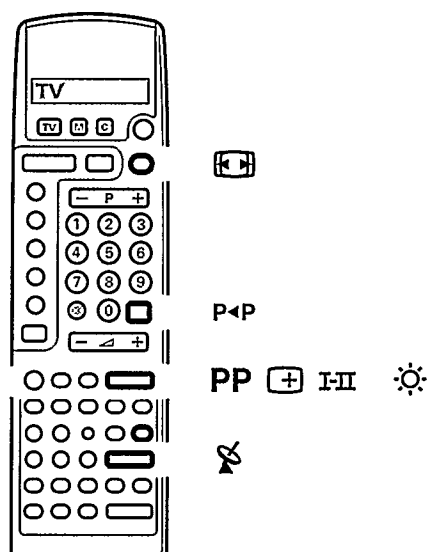

Picture format

- Press  repeatedly to select
 - . or a conventional picture format
 - . or a panoramic picture format
 - . or a full expanded picture format
 - . or a wide screen picture format.
- ▶ The information PANORAMA appears briefly on the screen if a panoramic picture format has been selected.
- ▶ The information MOVIE EXPAND appears briefly on the screen if a full expanded picture format has been selected.
- Keep MENU + pressed to move the full expanded picture upwards so that the subtitles, if there are, become visible at the bottom.
- Keep MENU - pressed to move the full expanded picture downwards again.
- ▶ The information WIDE SCREEN appears briefly on the screen if a wide screen picture format has been selected.

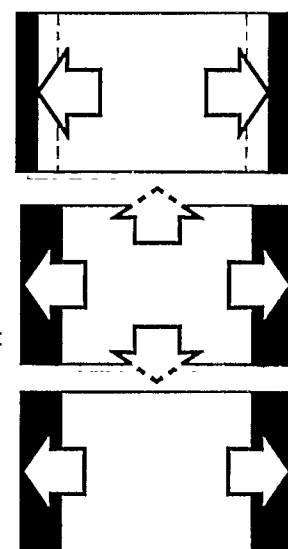

Making subtitles visible from pictures from VCR1, VCR2 or SAT

- Press the M on the remote control repeatedly until the designation TV appears in a grey block.
- Keep MENU + or - pressed to move the picture upwards or downwards again.
- Press the M again until the designation VCR1, VCR2 or SAT appears in a grey block.
- ▶ Now you can operate your video recorder 1 or 2 or satellite tuner again with the remote control of the TV.

Previous programme

- Press the P<P key.
- ▶ The previous selected TV channel is displayed again.
The  indication has a video recorder function.

Brightness

- Open the door of the remote control.
- Press  - or + in order to adjust the brightness.

Selecting satellites

The keys **S** - and **+** are only functional when having connected a satellite tuner in combination with a satellite positioner and an automatically rotatable polarmount antenna to select satellites.

PP key

With the green **PP**-key you can call up again the picture and sound adjustments which have been stored with the **PP store** in the Special Features menu, p.14.

- Open the door of the remote control.
- Press **PP**.

Information on screen

After the selection of a TV channel the following information appears briefly on your screen :

- . the programme number and name of the selected TV channel
 - . the actually selected sound mode if the TV-channel transmits stereo or digital sound
 - . **SOUND MUTED** when the sound is temporarily interrupted
 - . the name of the pip connection if pip is switched on.
See Pip-Picture in Picture, p.20
 - . **DUAL I** or **II** in case of bilingual broadcast.
- Open the door of the remote control.
 - Press **[+]** short.
 - ▷ The channel information appears on the screen for a few seconds.
 - ▷ If the sleeptimer is on, then the remaining time becomes visible.

PR1 BBC1

SOUND MUTED

English

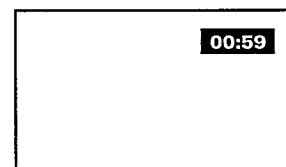

Permanent Programmnummer

- Open the door of the remote control.
- Press **[+]** long.
- ▷ The information appears on the screen for a few seconds and the permanent programme number remains in the upper right hand corner of the screen when it was off, or disappears when it was on.

Bilingual Broadcast

If you are watching a TV channel which is being broadcast in two languages, dubbed and original language, you can make your choice.

- Open the door of the remote control.
- Press key **I/II** and select language **I** or **II**.
- ▷ **DUAL I** or **II** appears for a moment on top of the screen.
The setting is stored in the memory for the selected TV channel when switching to another TV channel or to standby.

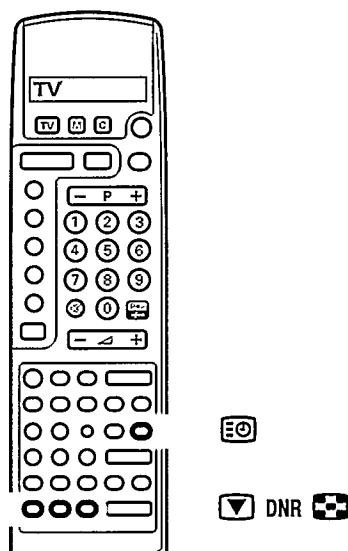

Time

The time can only be called up if the TV channel you are watching is also broadcasting teletext.

Teletext does not need to be switched on.

- Open the door of the remote control.
- Press **E@**.
- ▷ The time appears in the upper right hand corner of the screen.
- Press **E@** again in order to switch off.

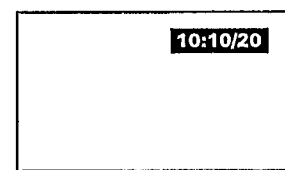

Freezing the picture

When watching you can freeze the picture at any moment.

- Press **▽**.
- Press **▽** again to return to normal picture.

DNR

With DNR, Dynamic Noise Reduction, you can reduce the noise when receiving a weak signal and so improve the picture quality.

- Press the DNR key repeatedly to select **DNR MIN**, **DNR MAX** or **DNR OFF**.
- ▷ Your selection appears for a moment on top of the screen.
DNR MIN offers you an optimum picture quality, and it is the most ideal setting for signals of normal strength.
DNR MAX is **not** necessary when the picture quality is good.

The setting is stored in the memory only for the selected TV channel after you have switched to another TV channel.

Mosaic screen

With the mosaic screen, you can scan the TV channels stored in the favourite list, display successive frozen pictures with the photo finish function and reproduce the main picture image by image with the strobe function.

- Press .
- ▷ A menu line appears on the bottom line of the screen. It contains four functions, each having another background colour, corresponding to the menu colour keys.
- Press the corresponding colour key to activate one of the 4 functions.

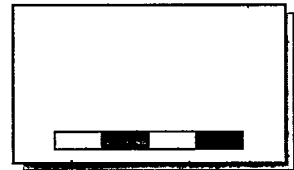

Scan

- Press the red key a.
- ▷ A scan of the stored TV channels is performed, starting with programme number 0.
Only TV channels placed in the favourite list or programmes from switched on peripherals are displayed. On the last position, bottom right, a live picture is shown of the programme that was displayed before the mosaic screen was switched on.
- Press the red key a again.
- ▷ A following series of stored TV channels from the favourite list or programmes from switched on peripherals is scanned.
Each mosaic picture will contain its belonging programme number.
- Select a TV channel with the digit keys.
- ▷ The mosaic screen disappears and the selected TV programme will be displayed.
- Press the blue key d to interrupt the scan function and to switch off the mosaic screen.

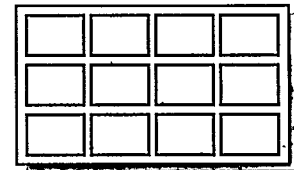

Never perform a scan while recording a TV programme with a video recorder connected to EXTERNAL 1 or 2 and when having selected an option in the Recording Source menu since the scan will be recorded on tape.

Photo finish

- Press the green key b.
- ▷ The main picture is displayed in successive frozen pictures.
The last picture on the bottom right will remain live.
- Press the green key b again.
- ▷ A new photo finish picture is displayed, overwriting the old one.
- Press the blue key d to switch off the photo finish function and to switch off the mosaic screen.
- ▷ The programme that was selected before the mosaic screen was switched on, appears again.

Strobe

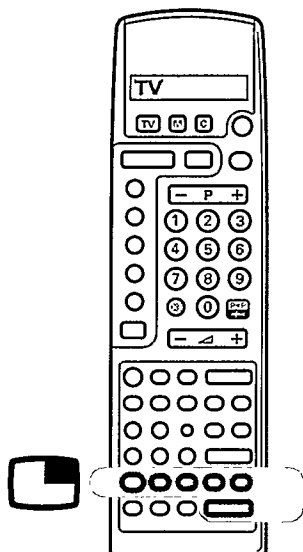

- Press the yellow key c.
- ▷ The picture is reproduced image by image. So you get an interrupted movement.
- Press the yellow key c again.
- ▷ The picture is reproduced image by image in a faster way.
- Press the yellow key c once again.
- ▷ The strobe function is switched off.
- Press the blue key d to switch off the mosaic screen.

Pip - Picture in Picture



With pip, picture in picture, you can call up a little screen within the main TV screen. Thus at the same time you can watch a programme from other equipment, connected with a eurocable. The picture in the small screen has no sound.

Switching pip on and off

- Open the door of the remote control.
- Press .
- ▷ The pip screen appears and the image is the same as in the main screen.
- ▷ The name of the pip programme appears briefly on the main screen.
- Press  again to switch pip off.

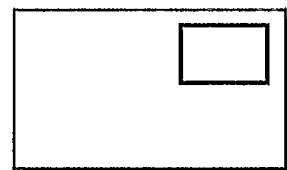

Selecting pip connections

- Press  repeatedly.
- ▷ The name of the connections appear. If any other electronic unit is connected and switched on, then its programmes appear in the pip screen. Select on your video recorder the TV channels which you have stored in it. For connecting equipment to EXTERNAL 1, EXTERNAL 2, FRONT, see Peripheral Equipment, p. 25.

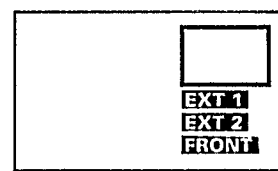

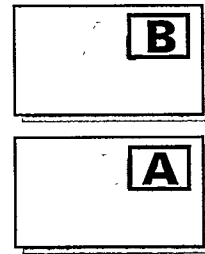

Switching screens

- Press .
- ▷ The main screen and the pip screen exchange places.
If the TV channel is only in the pip screen and not in the main screen, then use - P + of the pip keys in order to change your TV channel in the pip screen.



Still Picture

- Press .
- ▷ The picture in the pip screen stands still.
Even when pip is not switched on, the main screen will appear as a still picture in the pip screen.
- Press  again or select another channel in the pip screen in order to cancel the still picture.

Moving the Pip screen

- Press .
- ▷ Each time you press this key, the pip screen moves to another corner of the main screen.

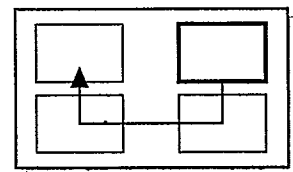

If the main screen is a full expanded picture format, the pip screen only moves to the upper left hand corner of the main screen.

Pip Size

You can select either a large or a small pip screen.
See Main Menu : Special Features, p.14.

Teletext

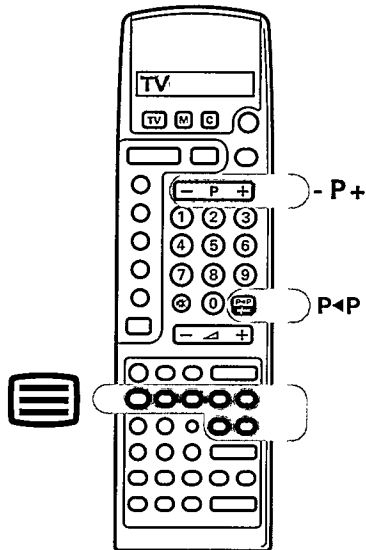

Most TV channels broadcast information via teletext. Each channel which broadcasts teletext transmits a page with information on how to use its teletext system. Look for the teletext page with the index (usually page 100). TV programmes are sometimes subtitled for the hard of hearing. Depending on the TV channel, teletext is transmitted in different systems: WST, TOP, FLOF. The system utilised is indicated in the options line at the bottom of the screen.

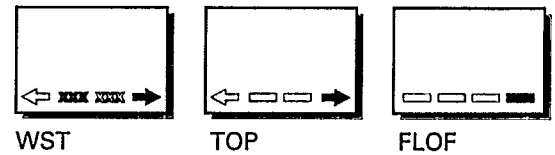

Switching Teletext On and Off

- o Select the TV channel for the desired teletext broadcast.
Teletext cannot be switched on when there is a menu on the screen.
- o Open the door of the remote control.
- o Press  in order to switch on the teletext.
- The contents appear on the screen together with two information lines at the top and an options line at the bottom.

When a selected teletext page contains several subpages, the subpage numbers which are automatically stored in the memory appear in the first information line. The coloured number indicates the displayed subpage. The white numbers refer to the subpages which can be selected with MENU - or +.

In the following information line appears:

- . the name of the TV channel selected
- . the page counter
- . date and time.

- o Press  again in order to switch off the teletext.
- The TV channel reappears.

Easy Teletext system

The major advantages of this new teletext system are :

A considerable **reduced waiting time** by predicting what the user will probably select and which results in :

- . a fast and direct selection of previous and following pages which are in transmission
- . the precapturing of the pagenumbers read from the displayed page
- . the direct selection of the last 2 page numbers selected with the digit keys
- . the precapturing of the pages referred to in the options line
- . the creation of a **habit watcher list** : not predictable pages, being selected by the user, are put in a list of preferred pages so that they are immediately available afterwards.

The precapturing of up to **9 subpages** to be controlled by the teletext user.

Selecting a Teletext Page

With the digit keys **OR** With the options line.....

- Enter the desired page number with the digit keys.
- ▷ The page counter seeks the page or the page appears immediately when the page number has been stored in the memory.
- ▷ A message appears when you have entered a not existing or an incorrect page number. Page numbers beginning with 0 or 9 do not exist.
- Enter the correct page number.
- Select with the colour keys, corresponding to the coloured options at the bottom of the screen and depending on the teletext the selected TV channel transmits,
 - the previous <= or the following => pages
 - the previous selected pages
 - another subject

Quickly run through the teletext pages

- Press **P** - to run through the previous pages.
- Press **P+** to run through the following pages.

Selecting the previous teletext page

- Press the **P+P** key.
- ▷ The previous selected teletext page is displayed again.

Selecting subpages

When a selected teletext page consists of different subpages, one of the subpages appears on the screen.

The coloured number in the first information line refers to the displayed subpage.

The other subpage numbers appear in white as soon as the transmission has found them.

- Press **MENU -** to select the previous subpage.
- Press **MENU +** to select the following subpage.

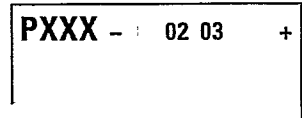



Selecting the table of contents

- Press the white colour key **e**.
- ▷ The table of contents appears.

Special teletext functions

Hold



You can stop the page counter from seeking when you have entered a wrong page number or when the page is not available.

- Press .
- ▷  appears in the first information line.
The page counter stops seeking the entered page number.
- Enter another page number.
- ▷  disappears.





Reveal

Some pages contain concealed information, such as solutions to riddles and puzzles.



- Press  to call up concealed information.
- Press  again in order to switch off the concealed information.

Interrupt



- Press .
- ▷ The TV programme appears.
- ▷  at the top of the screen indicates that you are still in the teletext mode.
Before interrupting teletext, you can select a page number.
When the page has been found, the information line appears briefly on your screen.
- Press  again.
- ▷ Teletext reappears.



Mix

- Press .
- ▷ The teletext page and the TV programme appear on the screen at the same time.
- Press  again.
- ▷ Only the teletext page is displayed.

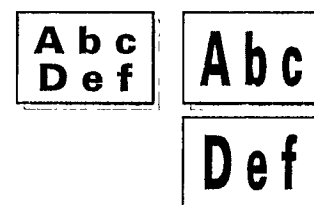

Enlarge

- Press  to enlarge the top half of the teletext page.
- Press  again to enlarge the bottom half of the teletext page.
- Press once more to return to normal page size.



Subpage

By adding a subcode you can call up a desired subpage.

- Enter the page number.
- Press .
- Enter the desired subpage with the digit keys : e.g. 3 for the third page of seven subpages.
- Press  in order to cancel the subcode.

Subtitles and newsflashes

- Select the contents page (usually page 100).
- Select the page number for subtitles or newsflashes.
- ▷ Subtitles or newsflashes, if there are, appear at the bottom of the TV programme.

Peripheral Equipment

There is a wide range of electronic equipment that can be connected to your TV.
The following connection diagrams show you where the different equipment should be connected at the back or the right side of the TV.

TV and video recorder

- Connect the aerial cables 1 and 2 as shown alongside. A better picture quality is obtained if you connect a eurocable 3 additionally.

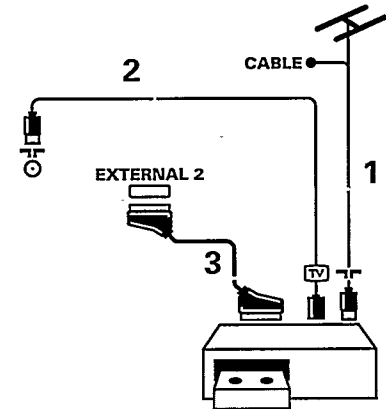

S-VHS video recorder

- Do you have a S-VHS video recorder with S-VHS cinch connectors, then connect as well as the aerial cables 1 and 2

the S-VHS cables 4 and 5

and the S-VHS cables 6 and 7.

Do not connect an additional eurocable.

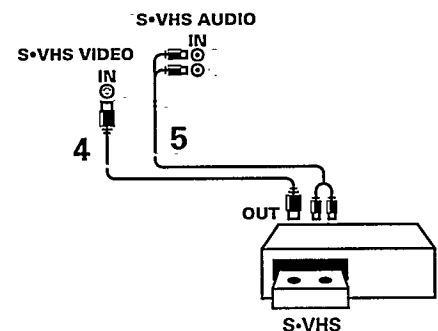

OR

- Do you have a S-VHS video recorder with a S-VHS euroconnector, then connect as well as the aerial cables 1 and 2, the S-VHS eurocable 3.

Never connect to the same TV one video recorder with S-VHS cables at the same time as one video recorder with a euroconnector.
The euroconnector has no function.

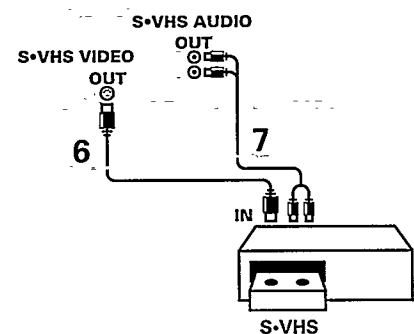

Searching for and storing the testsignal of the video recorder

- Unplug the aerial cable of the aerial socket ㊦ of your video recorder.
- Switch on your TV and video recorder.
- Press the **INSTALL** key at the right side of your TV, or enter the System Installation menu via the main menu.
- The **SYSTEM INSTALLATION** menu appears.
- Search for the testsignal of your video recorder in the same way as you searched for and stored the TV channels. See Installation, Searching for and storing TV channels, p. 5.
Store the testsignal either under programme number 0 or between 50 and 59.
- Insert the aerial plug again into the aerial socket ㊦ of your video recorder after you have stored the testsignal.

English

- TV, video recorder 1 and one or more peripherals**
- Connect the aerial cables 1, 2 and 3 as shown alongside. A better picture quality is obtained if you connect the eurocables 4 and 5 additionally.
 - Look for the test signal of your peripheral in the same way as you do for a video recorder.

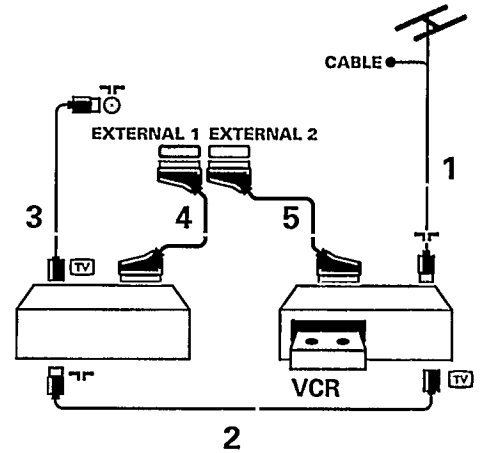

When having more than one peripheral, connect them to each other with an extra aerial cable 6 and an additional eurocable 7 to obtain a better picture quality.

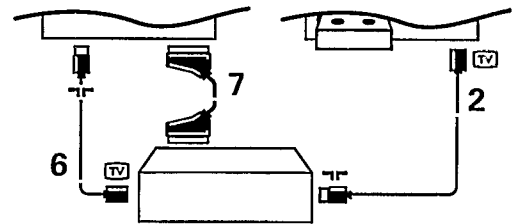

Only with a video recorder connected to EXTERNAL 2 it is possible to record a programme from your TV as well as from other connected equipment. See Recording with your video recorder, p. 31.

TV and laser disc or satellite tuner or Photo CD/CDI equipment

- Connect the aerial cables 1 and 2 as shown alongside. A better picture quality is obtained if you connect the eurocable 3 additionally. See also Installation, Photo CD/CDI, p. 9, if you connect a Photo CD/CDI equipment.

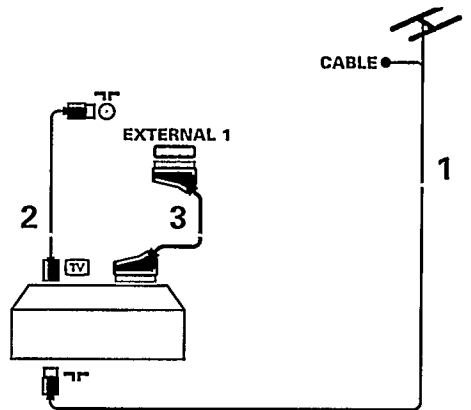

Look for the test signal of your equipment in the same way as you do for a video recorder.

Audio equipment

You can listen to your TV sound via your audio equipment.

- Therefore connect the audio cables to the audio input of your equipment and to AUDIO L and R at the back of your TV.
- Press on the remote control.
- ▷ The loudspeakers of your TV are switched off.

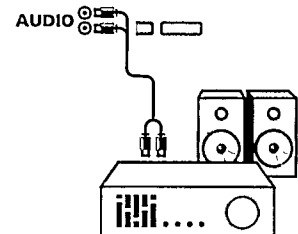

Camera and camcorder

- Connect your camera or camcorder to FRONT at the right side of your TV.
- Connect the equipment to VIDEO 1 and AUDIO L 2 for mono equipment.
- In the SOUND menu select mono sound. See Main Menu, Adjusting the sound, Sound mode, p. 13.
- Connect AUDIO R 2 for stereo equipment.
- In the SOUND menu select stereo sound. S-VHS quality with a S-VHS camcorder is obtained by connecting the S-VHS cables with the s-vhs input 3 and AUDIO inputs 2.

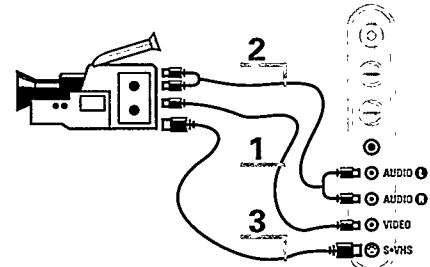

Extra loudspeakers

To achieve a better sound effect you can connect 2 of 4 extra loudspeakers, min. 8 Ohm.

See also Spatial and Surround sound, p. 12.

- Hold the connector clip pressed in and insert the ends of the wires into the openings. On the back of the TV it is indicated where you connect the FRONT and REAR loudspeakers.

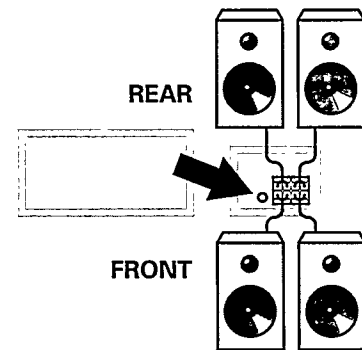



In case of 2 extra loudspeakers:

- Connect them to FRONT **or**
- Connect them to REAR.
- Press the loudspeaker switch on the back of the TV out.
- ▶ The internal loudspeakers of your TV are now switched off.
- ▶ You achieve a better front sound effect.
- ▶ You achieve a surround sound effect. A loudspeaker kit to achieve Surround Sound, containing two extra boxes only to be connected to REAR and 12 m wire can be purchased from your dealer. Do never connect the loudspeakers from these kit to FRONT.

In case of 4 extra loudspeakers :

- Connect them to FRONT and REAR.
- Press the loudspeaker switch on the back of the TV out.
- ▶ The internal loudspeakers of your TV are now switched off.

Headphone

- Insert the plug into the headphone socket  at the right side of the TV.
 - Adjust the volume with  - or +.
 - Press  on the remote control.
 - ▶ The internal loudspeakers of your TV are switched off.
- The headphone socket has an impedance of between 8 and 4000 Ohm and is of the 6.3 mm jack type.

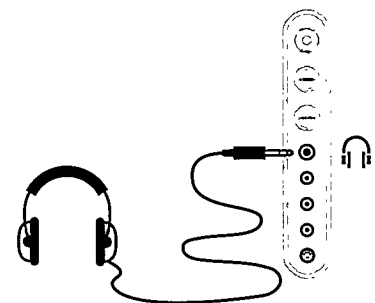

Decoders

Cable TV offers you a wide choice of programmes. Most of them are free, others are to be paid for by the viewer. This means that you will need to subscribe to the broadcasting organisation whose programmes you wish to receive. This organisation will supply you a corresponding decoder unit to allow the programmes to be unscrambled. For further information, ask your dealer. See also the booklet supplied with your decoder.

Connecting a decoder with an aerial socket to the TV

- Connect the aerial cables 1 and 2 as shown alongside. When your decoder has a euroconnector you obtain a better picture quality if you connect a eurocable 3 additionally.

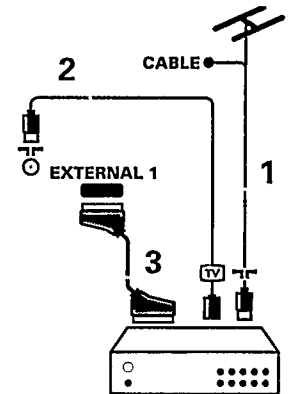

Connecting a decoder without an aerial socket to the TV

- Connect the decoder with your TV with a eurocable 3 only.

Connecting the decoder to the video recorder

Some video recorders have a special euroconnector for decoder.

- Connect a eurocable to the euroconnector of your decoder and to the special euroconnector of your video recorder. See also the handbook of your video recorder.
- To connect your video recorder to the TV, see before.

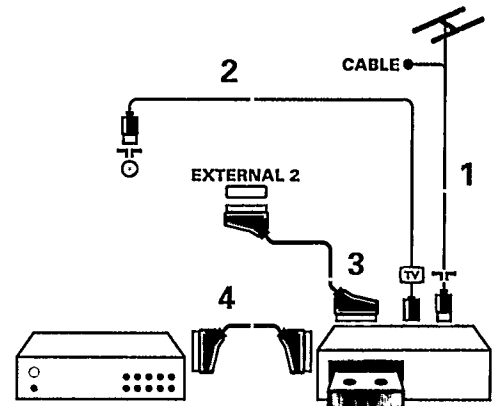

If you want to connect more equipment to your TV, consult your dealer.

Reproducing Picture and Sound

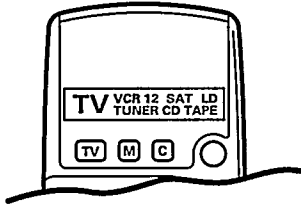

Most of the audio and video equipment from our range of products can be operated with the remote control.

a. from equipment connected only with an aerial cable

- Switch your TV on.
- With the digit keys select the programme number under which you have stored the test signal.
- Switch on the equipment with the remote control.
- ▶ The picture and/or sound is reproduced.

Do you want to watch TV again ?

- Enter the programme number of the TV channel which you want to watch with the digit keys.

b. from equipment connected with a eurocable

- Switch your TV on.
- Switch your equipment on.
- ▶ Either the picture and/or the sound is reproduced or descrambled.

If this is not the case :

- Press **C** repeatedly until the designation **EXT1**, **EXT2** or **FRONT** appears on the screen, according to where you connected your equipment at the back or the right side of your TV.
- Press **M** on the remote control repeatedly until the designation **VCR1**, **VCR2**, **SAT**, **LD**, **TUNER**, **CD** or **TAPE** appears in a grey block.
- ▶ Either the picture and/or the sound is reproduced.

Do you want to watch TV again ?

- Press the **TV** key under the display of the remote control.
- Press **C** repeatedly until the picture and/or the sound from the TV channels is reproduced.

c. from a S-VHS recorder connected with **S-VHS** cables

- Switch your TV on.
- Press **C** repeatedly until the indication **EXT2** appears on the screen.
- Press repeatedly on the **M** key of the remote control until **VCR1** appears in a grey block.
- Switch your S-VHS recorder on.
- ▶ The picture stored in your video recorder from a pre-recorded cassette or from a TV channel is reproduced.

d. from equipment connected to the **right side** of the TV

- Switch your TV on.
- Press **C** repeatedly until the indication **FRONT** appears on the screen.
- Switch your equipment on.
- ▶ The picture is reproduced.
Do you want to watch the TV picture again ?
- Enter the programme number of the TV channel which you want to watch with the digit keys.

Recording with your video recorder

1. Recording a TV programme

only using an aerial cable

- Select the programme number on your video recorder.
- Press record ● under the door of the remote control or on your video recorder.

using a eurocable connected to the euroconnector EXTERNAL 2

- Select the programme number on the TV.
- Press MENU.
- Press the corresponding colour key for RECORDING SOURCE in the MAIN MENU 2 menu.
- ▷ RECORDING SOURCE appears.
- Press the red key a.
- ▷ TV TO EXT 2 is displayed.
- Set your video recorder to record. (See the handbook for your video recorder.)
- Press record ● under the door of the remote control or on your video recorder.

using a eurocable connected to the euroconnector EXTERNAL 1

- Select the programme number on the TV.
- Set your video recorder to record. (See the handbook for your video recorder.)
- Press record ● under the door of the remote control or on your video recorder.

2. Recording a programme from connected peripheral equipment

- Switch on the equipment.
- Press MENU.
- Press the corresponding colour key for RECORDING SOURCE in the MAIN MENU 2 menu.
- ▷ RECORDING SOURCE appears.
- With the colour keys select the connection from which you want to record.
- ▷ Your selection lights up.
- Set your video recorder to record. (See the handbook for your video recorder.)
- Press record ● under the door on the remote control or on your video recorder.

RECORDING SOURCE	
a ■	TV to EXT 2
b ■	EXT 1 to EXT 2
c ■	FRONT to EXT 2
select : a-c menu off	

Tips

Poor Picture

Have you selected the correct TV system ?

Is your TV set or house aerial located too close to loudspeakers, non-earthed audio equipment or neon lights, etc. ?

Mountains or high buildings can cause double pictures or ghost images.

Sometimes you can improve the picture quality by changing the direction of the outside aerial.

Is the picture unrecognisable ? Check if you have entered the correct frequency or adjust the frequency by fine tuning. See Installation, p. 5.

Are brightness and contrast out of adjustment ? Press the **PP** key.

Switch off your TV overnight with  on the left side of the TV.

No picture

Is the aerial connected properly ? Are the plugs tightly connected in the aerial socket ? Is the aerial cable in good condition and does it have suitable plugs ? Are the connection facilities to a possible secondly installed TV in good condition ? If in doubt, consult your dealer.

NO PICTURE means that the selected peripheral equipment is transmitting no picture.

Did you press the correct keys on the remote control ?

Try it once more.

Did you press  again after switching on teletext ?

Has the child lock been switched off ? See Special Features, p. 14.

Sound

Did you perhaps interrupt the sound with the  key ?

Were the internal loudspeakers perhaps switched off by the switch on the back of your TV set ? See Extra loudspeakers, p. 27.

Is the sound coming out of only one loudspeaker ? Was the balance perhaps set to one extreme ? See **SOUND** menu, p. 12.

Select **SPATIAL ON** in the Sound menu if there is no sound coming out of the extra loudspeakers in back. See Spatial and Surround Sound, p. 12.

Remote control

Does your TV no longer respond to the remote control ? Check whether the indication **TV** appears in a grey block. Perhaps the batteries are empty. See Preparation, p. 2.

Menu

Did you select the wrong menu ? Once more press **MENU** or **off** to exit from the menu.

Connections

Check whether your peripheral equipment is in fact properly connected. See p. 25.

Have you switched on the peripheral equipment ?



No solution ?

Switch your TV set off and then on again.

Never attempt to repair a defective TV yourself.

Check with your dealer or call a TV technician when nothing helps.

Table of TV frequencies.
 Frequenztabelle der Fernsehsender.
 Liste des fréquences des émetteurs.
 Frequentietabel TV-zenders.
 Tabella delle frequenze delle trasmissioni.
 Lista de frequências.

Tabla de frecuencias de transmisión de televisión.
 Frekvens oversigt.
 Frekvenstabell.
 Tabell över TV-frekvenser.
 TV-taajukksien taulukko.

GB

The frequencies used by a cable company may differ from the frequencies on the table. Consult your cable company or your dealer for detailed information.

D

In Kabelfernsehanlagen können Abweichungen von den in den Frequenztabelle aufgeführten Frequenzen vorkommen. Bitte wenden Sie sich an Ihren Fachhändler oder Ihre Kabelfernsehgesellschaft, die Ihnen die zutreffenden Frequenzen mitteilt.

F

Les fréquences utilisées par une société de télédistribution peuvent être différentes de celles sur la liste des fréquences. Consultez votre société de télédistribution ou votre revendeur pour des informations plus détaillées.

NL

De frequenties die gebruikt worden door een kabelmaatschappij kunnen verschillen van deze op de tabel. Raadpleeg uw kabelexploitant of uw handelaar voor meer informatie.

I

Le frequenze usate da una società di teledistribuzione possono essere differenti da quelle sulla tabella. Consultate la società di teledistribuzione o il vostro rivenditore per informazioni specifiche.

E

Las frecuencias utilizadas por las empresas de distribución de señal por cable, pueden ser diferentes de las que se encuentran en esta tabla. Consulte con su compañía de distribución de televisión por cable o con su distribuidor para que le proporcionen una información más detallada.

P

As frequências utilizadas por uma sociedade de teledistribuição podem ser diferentes das indicadas na lista de frequências. Consultar a sociedade de teledistribuição ou o vendedor para informações mais detalhadas.

DK

Frekvenser benyttet af kabel operatører kan være afvigende fra disse, kontakt deres kabel operatør eller forhandler for nærmere information.

N

Frekvensene som benyttes på et kabelnett kan avvike fra de som er oppført i tabellen. Kontakt ditt kabel-TV selskap eller din forhandler for nærmere opplysninger.

S

Frekvenserna som används i kabel-TV-näten kan avvika från frekvenserna i tabellen. Kontakta ditt kabel-TV-bolag eller din radiohandlare för vidare information.

SF

Kaapeliyhtiöiden käyttämät taajuudet voivat poiketa taulukossa olevista taajuuksista. Tarkat tiedot saat kaapeliyhtiöstä tai myyjältä.

EUROPA		ITALY		FRANCE	
CHANNEL...FREQ (MHz)		CANALE...FREQ (MHz)		CANAL...FREQ (MHz)	
E2	48.25	A	53.75	2	55.75
E3	55.25	B	62.25	3	60.50
E4	62.25	C	82.25	4	63.75
S1		105.25	5		176.0
S2		112.25	6		184.0
S3		119.25	7		192.0
S4		126.25	8		200.0
S5		133.25	9		208.0
S6		140.25	10		216.0
S7		147.25	B		116.75
S8		154.25	C		128.75
S9		161.25	D		140.75
S10		168.25	E		159.75
S11		231.25	F		164.75
S12		238.25	G		176.75
S13		245.25	H		188.75
S14		252.25	I		200.75
S15		259.25	J		212.75
S16		266.25	K		224.75
S17		273.25	L		236.75
S18		280.25	M		248.75
S19		287.25	N		260.75
S20		294.25	O		272.75
S21		303.25	P		284.75
S22		315.25	Q		296.75
S23		327.25	H1		303.25
S24		339.25	H2		311.25
S25		351.25	H3		319.25
S26		363.25	H4		327.25
S27		375.25	H5		335.25
S28		387.25	H6		343.25
S29		399.25	H7		351.25
S30		411.25	H8		359.25
S31		423.25	H9		367.25
S32		435.25	H10		375.25
S33		447.25	H11		383.25
H1		303.25	H12		391.25
H2		311.25	H13		399.25
H3		319.25	H14		407.25
H4		327.25	H15		415.25
H5		335.25	H16		423.25
H6		343.25	H17		431.25
H7		351.25	H18		439.25
H8		359.25	H19		447.25
H9		367.25	21		471.25
H10		375.25	22		479.25
H11		383.25	23		487.25
H12		391.25	24		495.25
H13		399.25	25		503.25
H14		407.25	26		511.25
H15		415.25	27		519.25
H16		423.25	28		527.25
H17		431.25	29		535.25
H18		439.25	30		543.25
H19		447.25	31		551.25
21		471.25	32		559.25
22		479.25	33		567.25
23		487.25	34		575.25
24		495.25	35		583.25
25		503.25	36		591.25
26		511.25	37		599.25
27		519.25	38		607.25
28		527.25	39		615.25
29		535.25	40		623.25
30		543.25	41		631.25
31		551.25	42		639.25
32		559.25	43		647.25
33		567.25	44		655.25
34		575.25	45		663.25
35		583.25	46		671.25
36		591.25	47		679.25
37		599.25	48		687.25
38		607.25	49		695.25
39		615.25	50		703.25
40		623.25	51		711.25
41		631.25	52		719.25
42		639.25	53		727.25
43		647.25	54		735.25
44		655.25	55		743.25
45		663.25	56		751.25
46		671.25	57		759.25
47		679.25	58		767.25
48		687.25	59		775.25
49		695.25	60		783.25
50		703.25	61		791.25
51		711.25	62		799.25
52		719.25	63		807.25
53		727.25	64		815.25
54		735.25	65		823.25
55		743.25	66		831.25
56		751.25	67		839.25
57		759.25	68		839.25
58		767.25	69		855.25
59		775.25			
60		783.25			
61		791.25			
62		799.25			
63		807.25			
64		815.25			
65		823.25			
66		831.25			
67		839.25			
68		839.25			
69		855.25			

