

Panasonic

Operating Instructions

Colour Television

TX-29GF85 series

TC-29GF80 series

TC-29GF82 series

TC-29GF85 series

TX-33GF85 series

TC-33GF85 series

This is a combined Operating Instruction manual for all the above series of models.

Please read these instructions before operating your set and retain them for future reference.

Dear Panasonic Customer

Welcome to the Panasonic family of Customers. We hope that you will have many years of enjoyment from your new colour television set.

To obtain maximum benefit from your set, please read these Instructions before making any adjustments, and retain them for future reference.

Retain your purchase receipt also, and note down the Model Number and Serial Number of your set in the space provided on the rear cover of these Instructions.

How to Use This Manual	6
Quick Reference Guide for your TV Set	7
Connect the Aerial Cable to the RF In Terminal	8
Connecting Woofer Speakers	9
Connect the Plug to the wall outlet	9
How to Turn the Power On	9
Battery Installation	10
Channel Selection	20
Country System Selection	22
Automatic Tune	24
Manual Tune	26
Fine Tuning	28
How to Cancel the Fine Tuning Function	29
Programme Number Skip	30
How to Cancel the Skip Function	31
How to switch the power ON or OFF/Stand-By Mode	32
Programme Number Selection	32
Direct Programme Number Selection	32
TV/AV Mode Selection	32
Volume Adjustment	33
Display Button	33
Mute Button	33
GAME Button	33
Recall Button	33
Off Timer Button	33
Sound System Selection	34
Colour System Selection	35
STROBE and DSP (Digital Surround Processor) Operation	36
Stereo Reception (For TC-29GF82G, TC-29GF82H, TC-29GF85G, TX-33GF85X, TC-33GF85G, TC-33GF85H)	37
Picture Menu Operation	38
Sound Menu Operation	39
DSP Menu Operation	41
Feature Menu Operation	42
LANGUAGE Menu Operation	43
Picture in Picture Operation (For TX-29GF85T, TC-29GF85G, TC-29GF85R, TX-33GF85T, TX-33GF85X, TC-33GF85G, TC-33GF85H)	44

⚠ Warnings

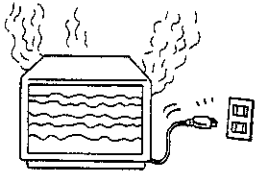

Unplug the power cord in the event of any malfunction (screen goes blank, no sound, odd sounds, smoke or unusual odors coming from the unit).
Unplug the power cord if foreign matter or water falls into the unit, or if the unit is dropped or the cabinet is damaged.

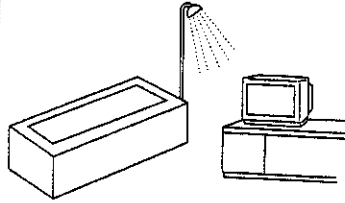

DO NOT use this unit near water. (near a bath tub, etc.)

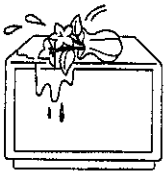

DO NOT place any of the following on the unit: Flower vases, flower pots, cups, small metal objects, or cosmetics containers, chemicals or water.

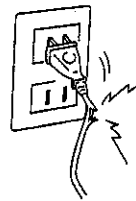

DO NOT use if the power cord or power plug is damaged, or if the plug does not fit tightly into the socket.

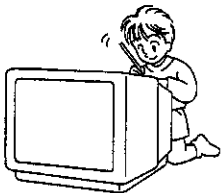

DO NOT insert foreign objects (metal or easily flammable objects).

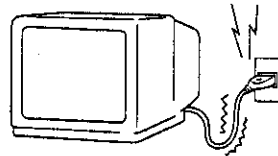

DO NOT use at a voltage other than indicated.

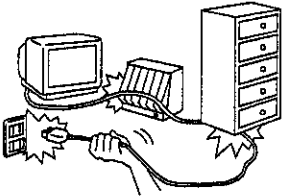

TAKE CARE NOT to damage the power cord.

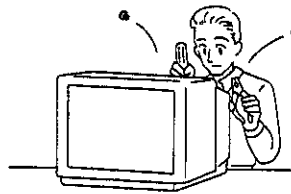

DO NOT remove the rear cover as live parts and High Voltage components are accessible when the rear cover is removed.

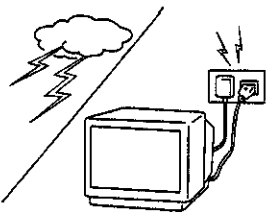

DO NOT touch the aerial cable and this unit when there is lightning.

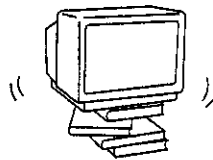

DO NOT place in an unstable location.

⚠ Cautions

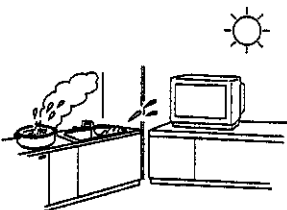

DO NOT place in humid or dusty locations, or areas exposed to smoke or steam.
DO NOT place the direct sunlight and other sources of direct heat.

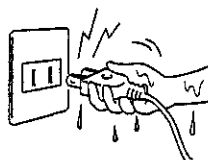

DO NOT touch the power plug if your hands are wet.

⚠ Cautions

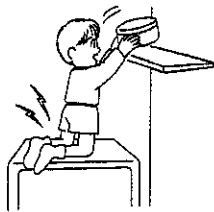

DO NOT stand, or place heavy objects on the unit. Particular care should be taken by families with small children.

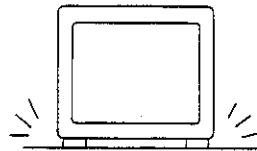

Place in a safe location.

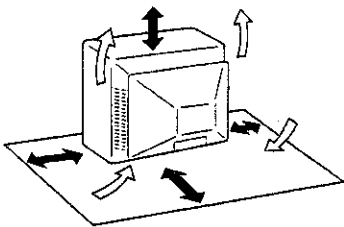

Adequate ventilation is essential to prevent failure of electrical components, we recommend that a gap of at least 10cm (\longleftrightarrow) is left all around this unit even when it is placed inside a cabinet or between shelves.

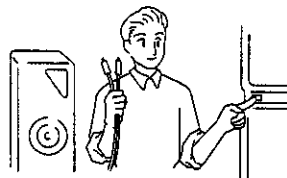

Turn the power "Off" before connecting other electrical equipment.

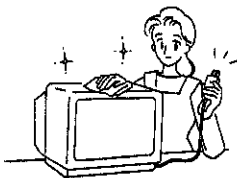

Before cleaning, unplug the power plug from the socket.



DO NOT jolt the unit.

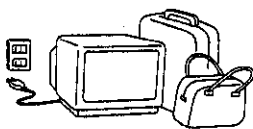

Unplug the power plug from the socket if you are not going to use the unit for an extended period.

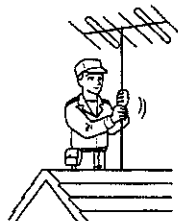

Ask your sales outlet to install the aerial.

Cleaning



The unit contains many plastic parts. For this reason DO NOT use benzene, thinner or other chemicals to clean the unit.

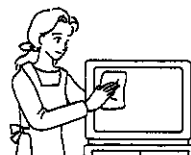

Dust will accumulate on the picture screen. Please wipe with a soft cloth from time to time. If you use a chemically treated cloth, please be careful to follow the instructions that come with the cloth.

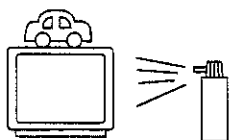

DO NOT bring into contact with insecticide or other volatile substances. DO NOT allow the unit to come into contact for extended periods with rubber or vinyl products.



Remove dirt and soiling by wiping with a light cloth. Even if the unit is heavily soiled, do not apply cleaner directly to the unit. Soak a cloth in a solution of neutral cleanser thinned with water. Then wring out the cloth, wipe the unit clean, and finish by wiping with a dry cloth.

How to Use This Manual

1. Check the Model Number of your TV set; the Model Number is shown on the rear cover name plate on the set. Use the table on the opposite page to confirm which features your particular Model is equipped with. This will help you to know which sections of the manual apply to your set.
2. Check the Part Number on the rear of your Remote Control handpiece, and note the functions available, as shown below.

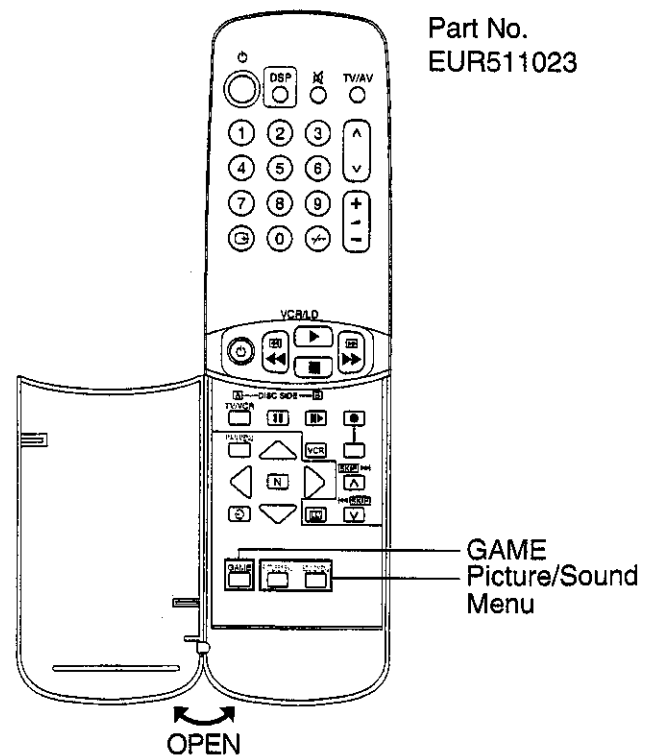
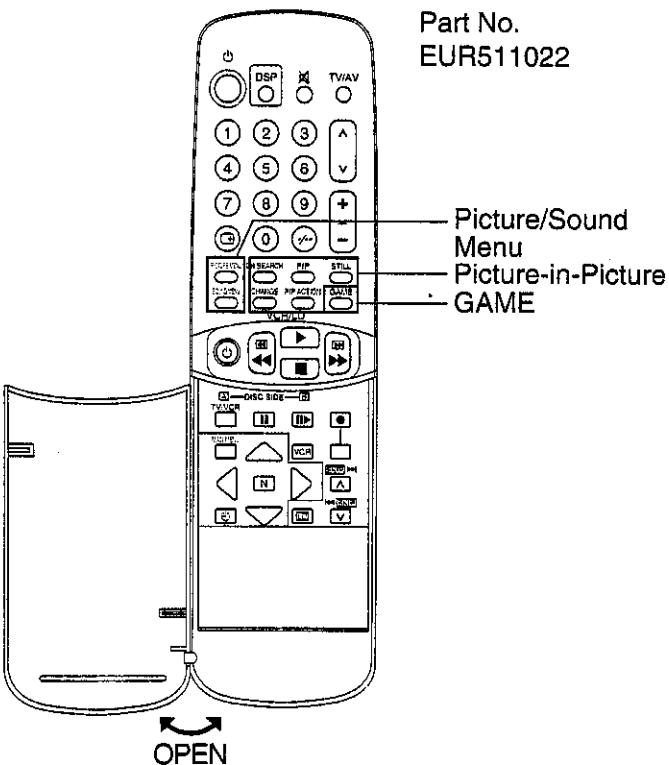
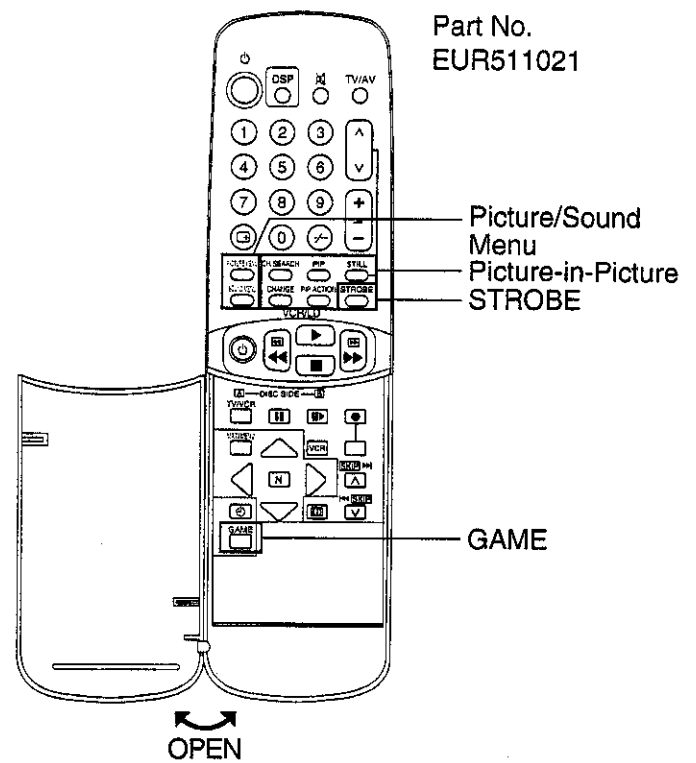
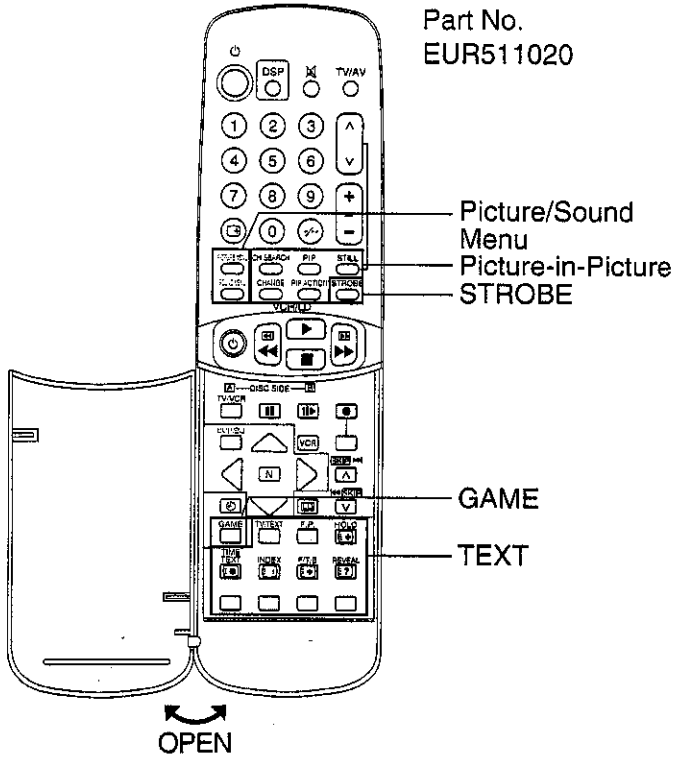

Quick Reference Guide for your TV Set

Please check the model number of your TV set.
 This Manual applies to several Models and there are slight differences among them.

Please check the table below to see what your TV is equipped with before you begin using these Operating Instructions. Instructions are given for all functions, please disregard these which do not apply to your TV.

Model No.		TX-29GF85T	TC-29GF80R	TC-29GF82G	TC-29GF82H	TC-29GF85G	TC-29GF85R	TX-33GF85T	TX-33GF85X	TC-33GF85G	TC-33GF85H	Refer to page(s)
Stereo	TRIPLE			*	*	*			*	*	*	P37
	MONO	*	*				*	*				
TEXT	English							*				P46~P49
	Russian	*					*					
CATV	HYPER	*	*	*	*	*	*	*	*	*	*	P54
PIP (2 TUNER)		*			*	*	*	*	*	*	*	P44
STROBE		*			*		*	*	*	*	*	P36
Headphones	2 System (Main/Sub)	*			*	*	*	*	*	*	*	P16
	1 System		*	*	*							P17
Multi Language	English	*	*	*	*	*	*	*	*	*	*	P43
	Chinese		*	*	*	*	*		*	*	*	
	Russian	*						*				
Power Source	110-240V 50/60Hz	*	*	*	*	*	*	*	*	*	*	P54
Tuning System	Frequency synthesizer	*	*	*	*	*	*	*	*	*	*	P55
Receiving System	21 System	*	*	*	*	*	*	*	*	*	*	P54

* : Function available

Connect the Aerial Cable to the RF In Terminal

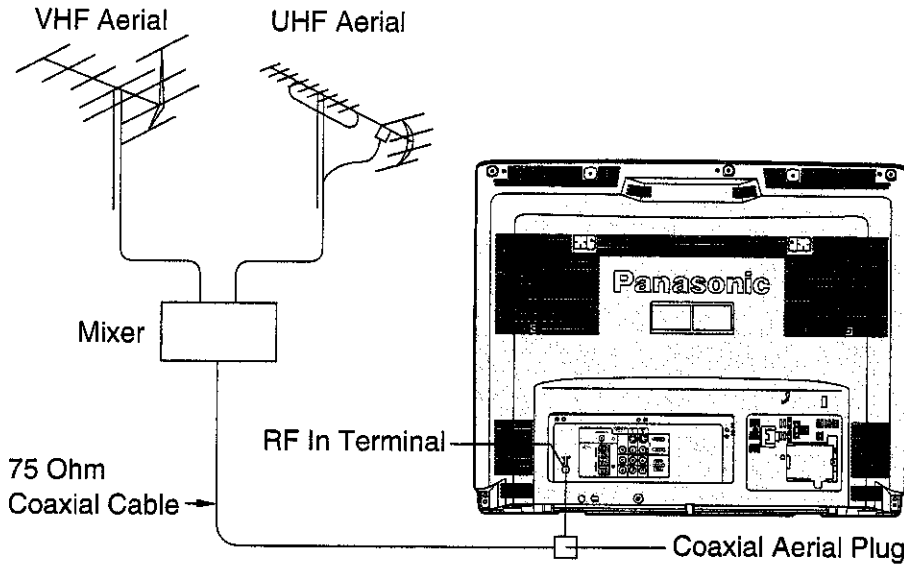

To obtain optimum quality picture and sound, an Aerial, the correct cable (75 Ohm coaxial) and the correct terminating plug are required.

If a communal Aerial system is used, you may require the correct connection cable and plug between the wall Aerial socket and your television receiver.

Your local Television Service Centre or Dealer may be able to assist you in obtaining the correct Aerial system for your particular area and accessories required.

Any matters regarding Aerial installation, upgrading of existing systems or accessories required, and the costs incurred, are the responsibility of you, the Customer.

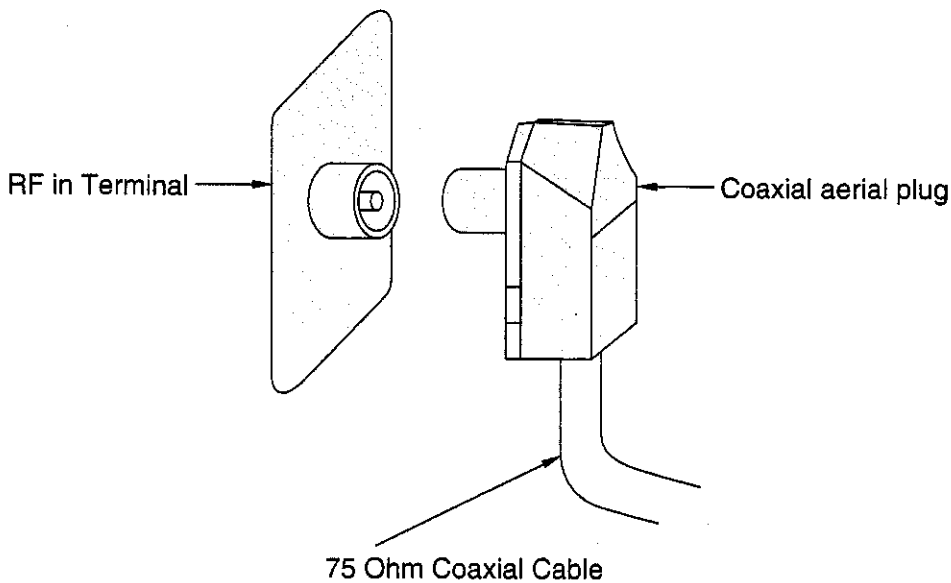

Connecting Woofer Speakers

Connect the woofer speaker as follows.

When a woofer speaker plug is inserted into the Woofer Terminal.

1. Fix the woofer speaker to the position as shown below.

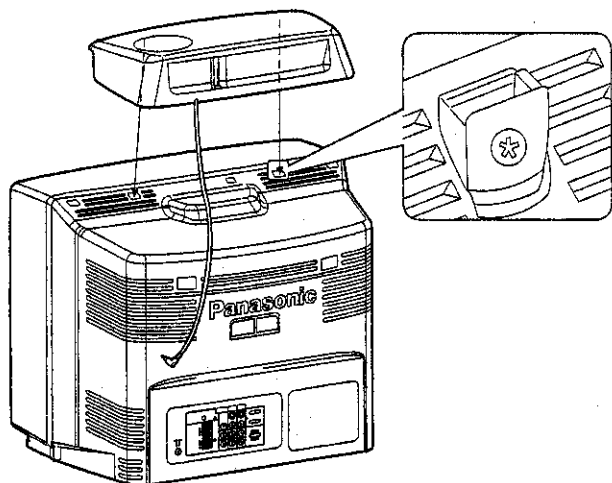

2. Insert the woofer speaker plug into the woofer terminal.

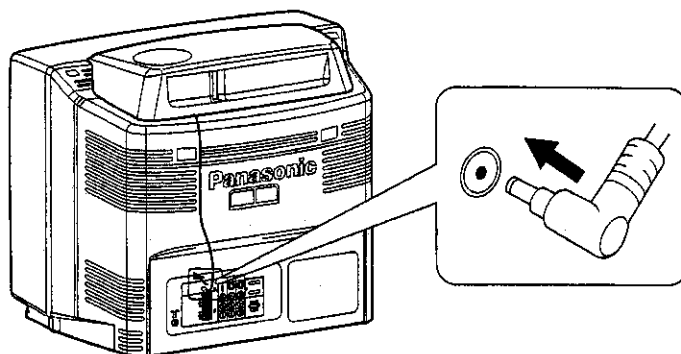

Connect the Plug to the Wall Outlet

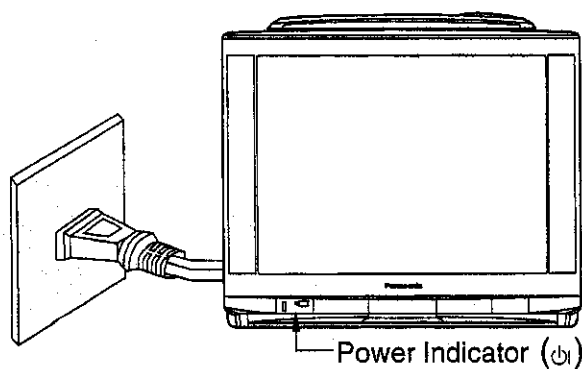

Power Indicator (⏻)

Note:

Mains plug types vary between countries. The mains plug shown at left may therefore not be the type fitted to your set.

When connecting the mains plug to the wall outlet, the power indicator will light (Orange).

How to Turn the Power On

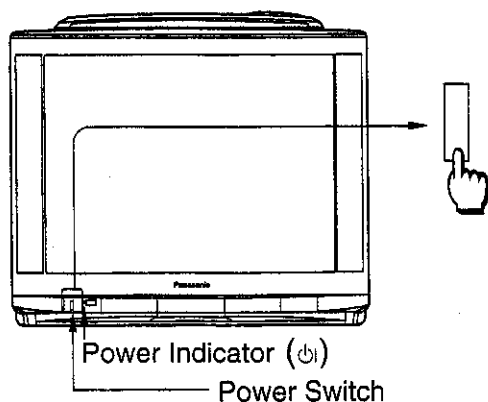

Power Indicator (⏻)

Power Switch

Push the Power switch on the Television to turn the set on.

The Power Indicator will light.

Power-OFF Orange

Stand-by ⏻ Red

Power-ON Green

Note:

When in the Stand-by condition (Refer to page 32), it is possible to turn the TV set on by pushing the "Power (Stand-by)" Button any of the "Direct Programme Number Selection" Buttons(0~9) and Programme Number Up and Down Buttons on the TV set or Remote Control.

Battery Installation

1

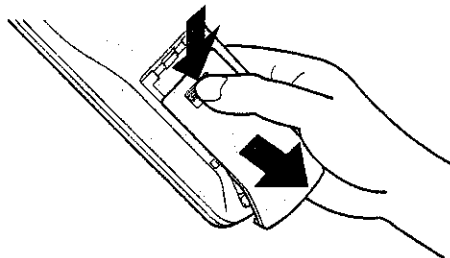

Open the cover.

Apply slight downward pressure while pulling towards the bottom.

2

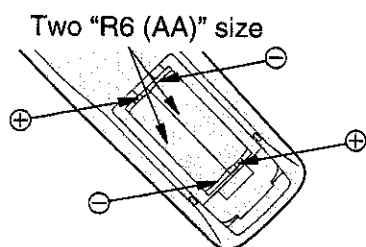

Batteries: Use two "R6 (AA)" size batteries.

Insert the batteries ensuring correct polarity.

This is identifiable by the "+" and "-" symbols on both the batteries and inside the battery compartment.

3

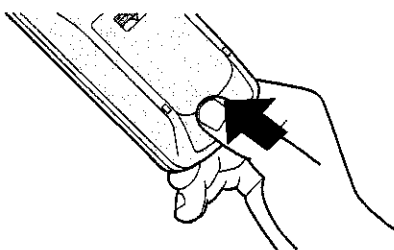

Replace the cover.

Do not use rechargeable (Ni-Cd) batteries.

They are different in shape and performance and may fail to ensure correct operation.

Battery cautions

The incorrect use of batteries can cause electrolyte leakage which will corrode the Remote Control or cause the batteries to burst.

Old Batteries

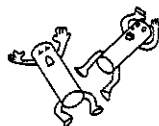

New Batteries



Replace both batteries at the same time.



Don't mix battery types
(alkaline with carbon zinc, etc.)

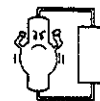

Don't Recharge.

Controls and Terminals on the TV

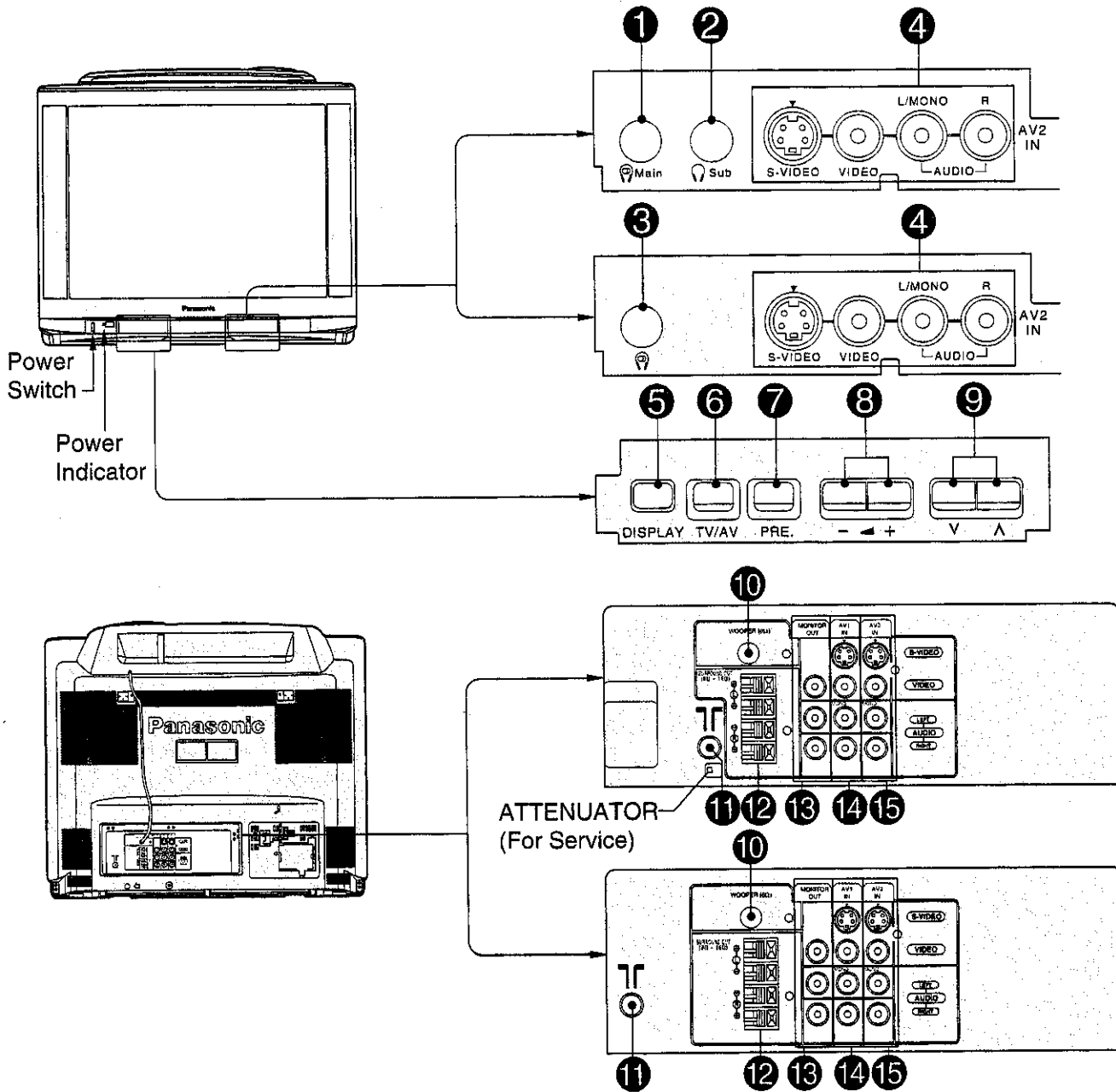

Item No.	Description/Function	Refer to Page	Item No.	Description/Function	Refer to Page
1	Main Headphones Jack	16	9	Programme Number Up (^) and Down (v)	32
2	Sub Headphones Jack	16	10	Woofer Speaker Terminal	9
3	Headphones Jack	17	11	Aerial Terminal (RF In Terminal)	8
4	AV2 Input Terminals	14	12	Surround Speaker Terminals	15
5	Display	33	13	Monitor Output Terminals	15
6	TV/AV Selection	32	14	AV1 Input Terminals	14
7	Preset	20, 22	15	AV3 Input Terminals	14
8	Volume Up (+) and Down (-)	33			

Remote Control

Part No.
EUR511022

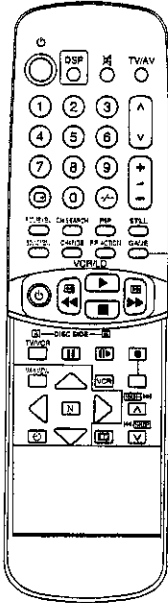

Part No.
EUR511023

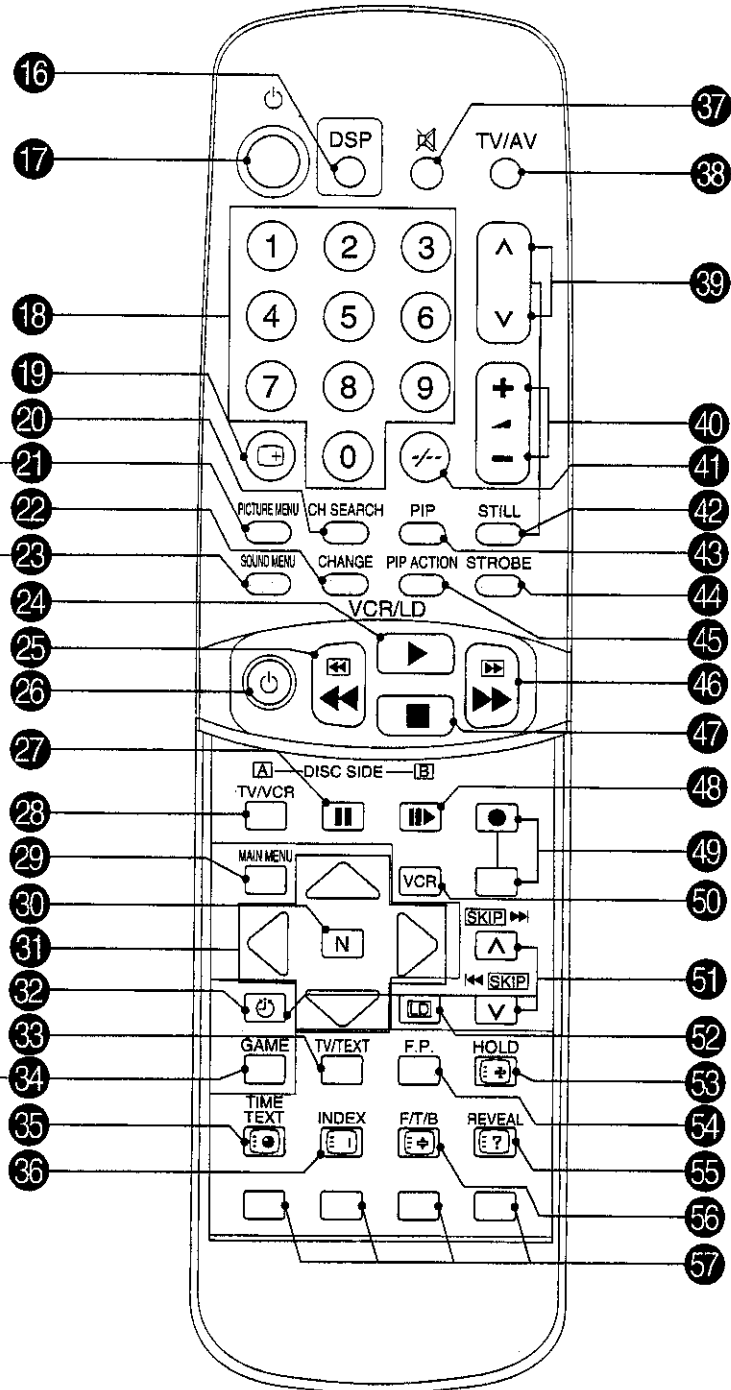
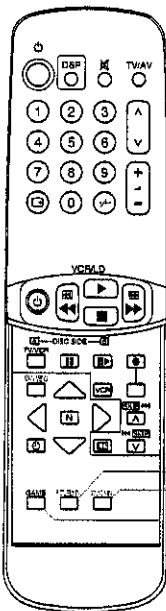

Note:

- (1) This illustration shows the Remote Control with maximum features.
(Remote Control No. EUR 511020)
- (2) The buttons shaded are not present for Models not equipped with certain features. The diagram on page 6 and the table on page 7 identify such variations.

Item No.	Function	Refer to Page	Item No.	Function	Refer to Page
16	DSP (Digital Surround Processor)	36	37	Sound Mute	33
17	Power (Stand-by)	32	38	TV/AV Mode Selection	32
18	Direct Programme Number Selection	32	39	Programme Number Up and Down	32
19	Recall	33	40	Volume Up and Down	33
20	Sub picture Channel Search	45	41	Two Digit Programme Number Selection	32
21	Picture Menu Selection	38	42	STILL	45
22	Main/Sub picture Change	44	43	Picture in Picture Selection	44
23	Sound Menu Selection	39	44	STROBE	36
24	VCR/LD Play	51	45	PIP ACTION	44, 45
25	VCR/LD Rewind/Peview	51	46	VCR/LD Fast Forward/Cue	51
26	VCR/LD Power	51	47	VCR/LD Stop	51
27	VCR/LD Pause Still	51	48	VCR Still/Advance (VCR) DISC SIDE B Selection (LD)	51
28	TV/VCR Mode Selection (VCR) DISC SIDE A Selection (LD)	51	49	VCR Record	51
29	Main Menu Selection	18	50	VCR Button	50
30	Normalisation	40	51	Programme Number Up and Down (VCR) Programme Number Skip (LD)	51
31	Position Buttons	18	52	LD Button	50
32	OFF Timer Selection	33	53	TEXT Hold	47
33	TV/TEXT Selection	47	54	TEXT Favourite Page Selection	47
34	GAME	33	55	TEXT Reveal	47
35	Time Text	48	56	TEXT Full/Top/Bottom Selection	47
36	TEXT Index	47	57	TEXT Colour-coded Buttons	47

How to connect the "AV1, 2 or 3" Input Terminals.

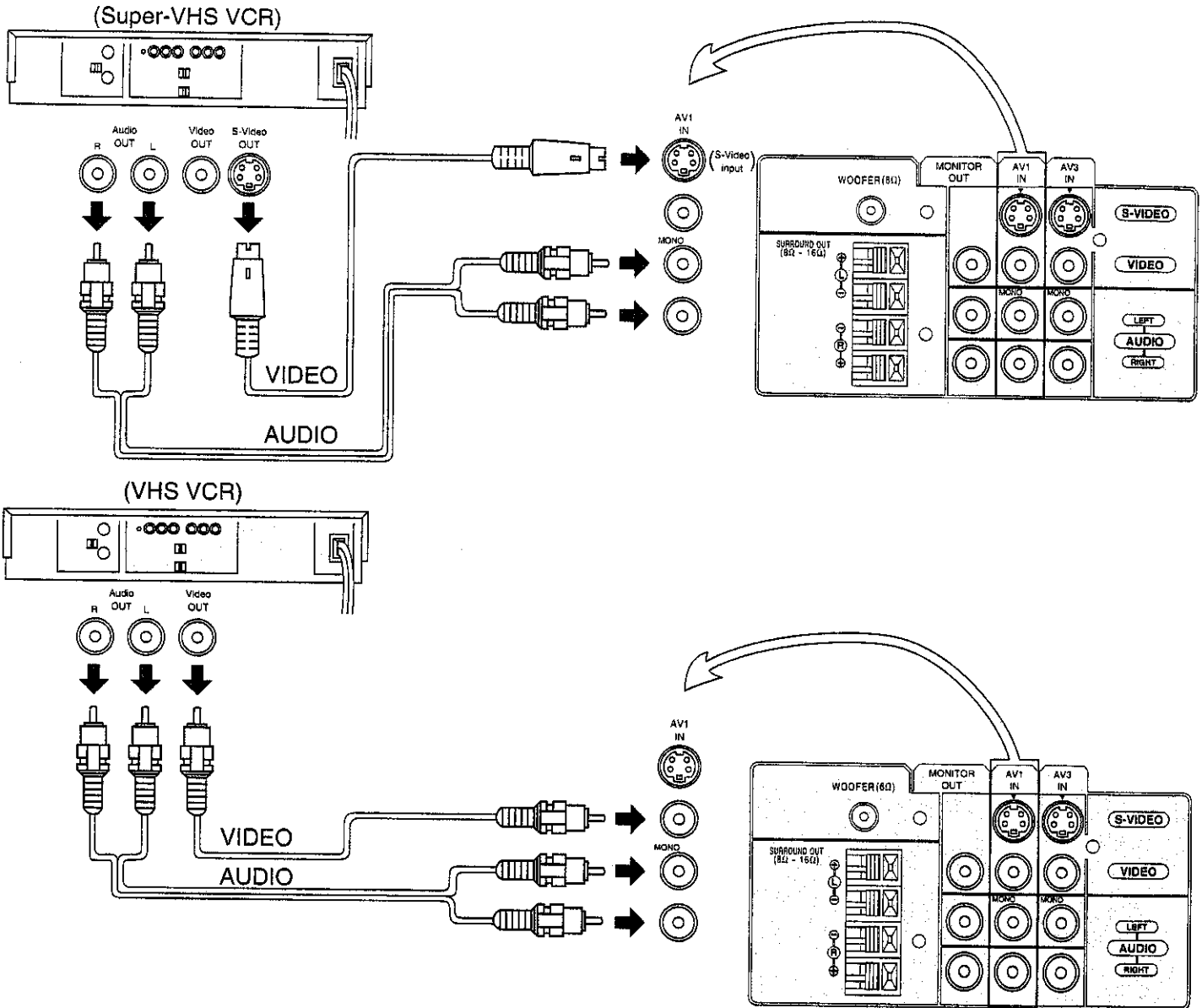

Note:

- (1) When AV1, AV2 or AV3 is selected, and that AV mode has no input picture signal, the Background Colour of the TV screen will change. (This only occurs if the Blue-Back function is set to the ON condition; refer to page 42 for details.)
- (2) When an S-Video cable is connected to the S-Video terminal, the Phono Video input will be automatically switched off for that AV mode.
- (3) When a Monaural VCR is used, connect the Monaural Audio cable to the Audio "L" (Left) terminal.
- (4) Similar connections are available at the AV1, AV2 and AV3 input terminals.
Select the desired AV input position by pushing the TV/AV button. (Refer to page 32)

How to connect the AV Monitor Output Terminals to other equipment.

The "Monitor Out" Terminals output the same signals as are on the TV screen at that time, e.g. TV programmes or signals from AV1, AV2 or AV3 input.

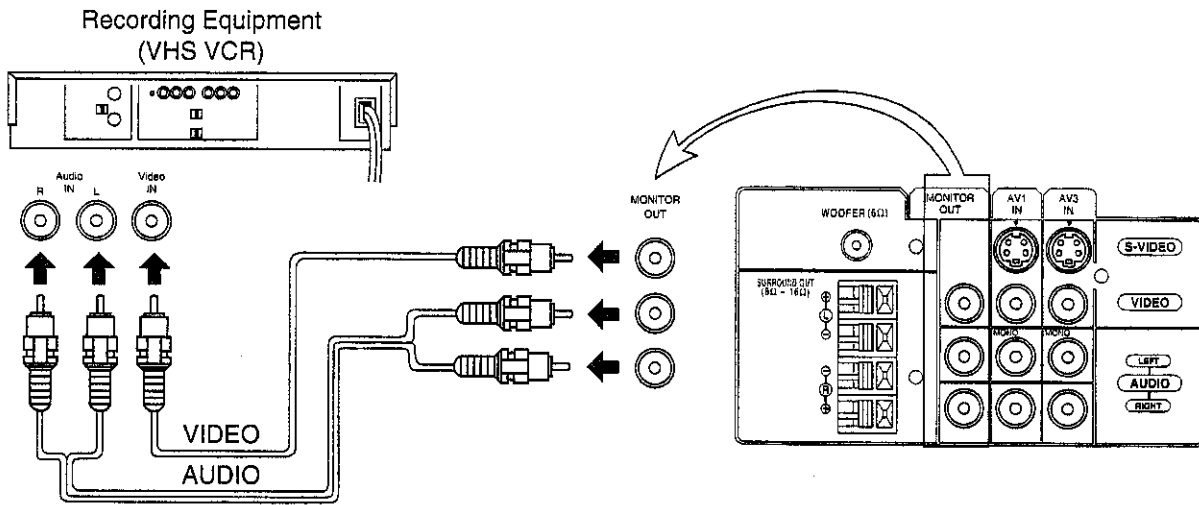

Note:

- (1) Never connect the same video recorder with both the VIDEO IN and MONITOR OUT terminals on this TV set, as this could cause incorrect operation.
- (2) The monitor output emits the main picture normal video and audio signals.
- (3) Teletext displays on screen will not be output at the MONITOR OUT terminals.
- (4) Even if the television in picture-in-picture condition, MONITOR OUT terminals output the same signals as main picture on the screen and sound from speakers. Sub picture including strobe, still, channel search, etc. will not be output at the MONITOR OUT terminals.

Connecting Surround Speakers

Connect the surround speakers as follows.

The Surround effect is enhanced by connecting external surround speakers. (optional)

Although it is possible to enjoy the "Surround effect" with this TV set as it is, upon connecting separate "Surround Speakers" the presence of the enveloping sound becomes more vivid.

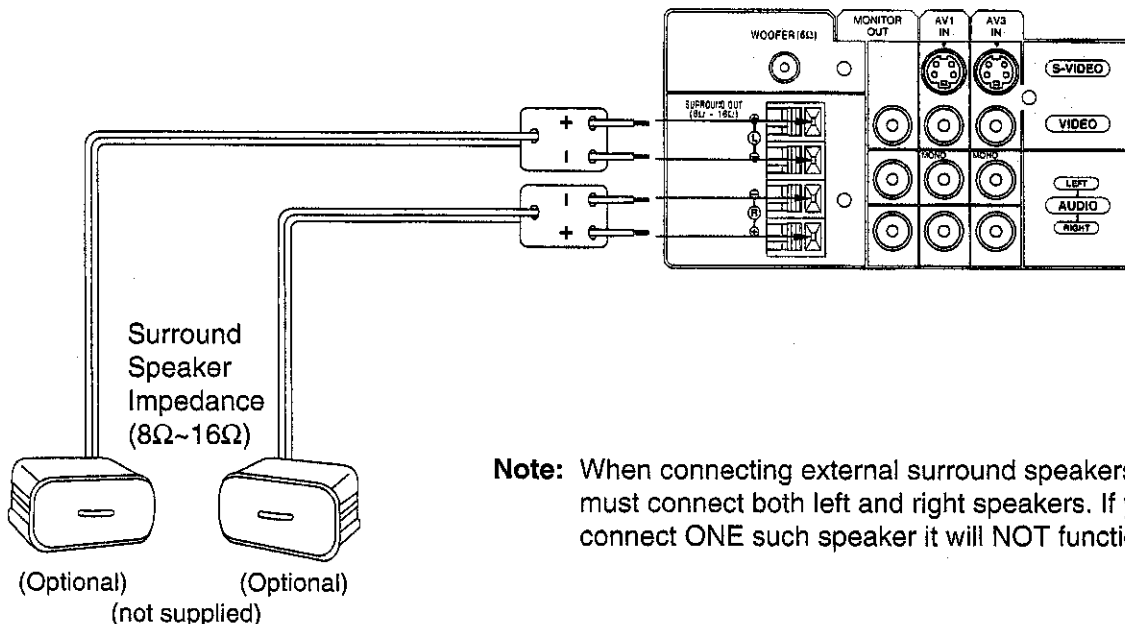

Note: When connecting external surround speakers, you must connect both left and right speakers. If you only connect ONE such speaker it will NOT function.

Connecting Headphones (For TX-29GF85T, TC-29GF85G, TC-29GF85R, TX-33GF85T, TX-33GF85X, TC-33GF85G, TC-33GF85H)

Connect headphones as follows.

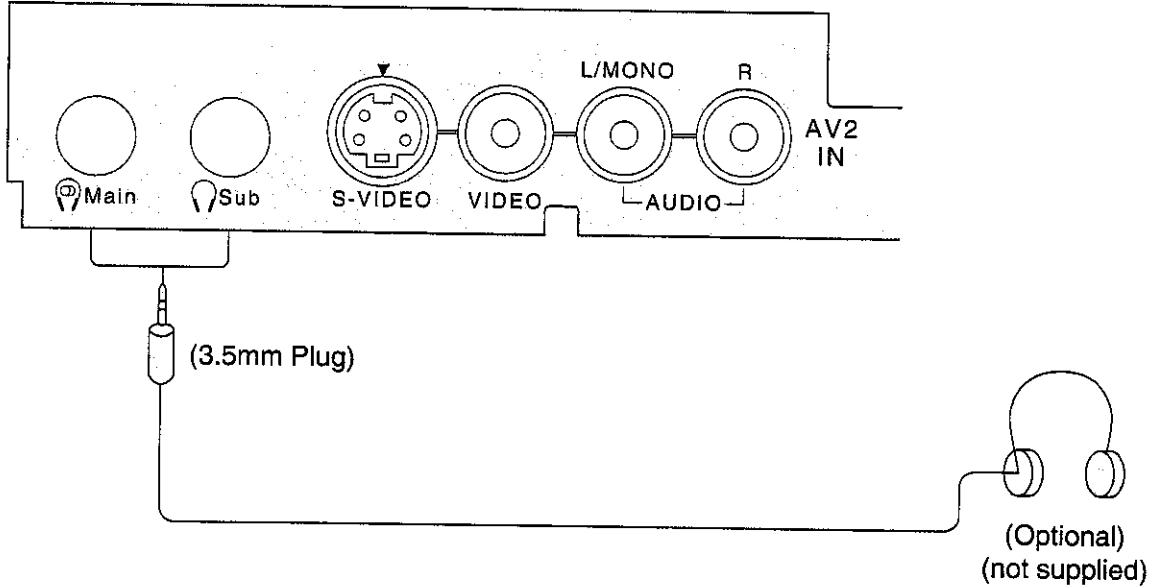

You can listen to sound from each of the headphone plugs as shown below.

Screen condition	Speaker Sound	Main Headphones	Sub Headphones	Monitor Output
Single picture/ Teletext	A (Stereo)	A (Stereo)	A (Mono)	A (Stereo)
Picture in Picture	A (Stereo)	A (Stereo)	B (Mono)	A (Stereo)
Picture in Picture/ CHANGE	B (Stereo)	B (Stereo)	A (Mono)	B (Stereo)

Main Headphones plug:

When a Main Headphones plug is inserted into the Headphones socket all speakers will be automatically disconnected; only the Main Headphones will function.

Use Volume Up "+" or Down "-" Button to control volume level.

Sub Headphones plug:

For the volume control, refer to page 45.







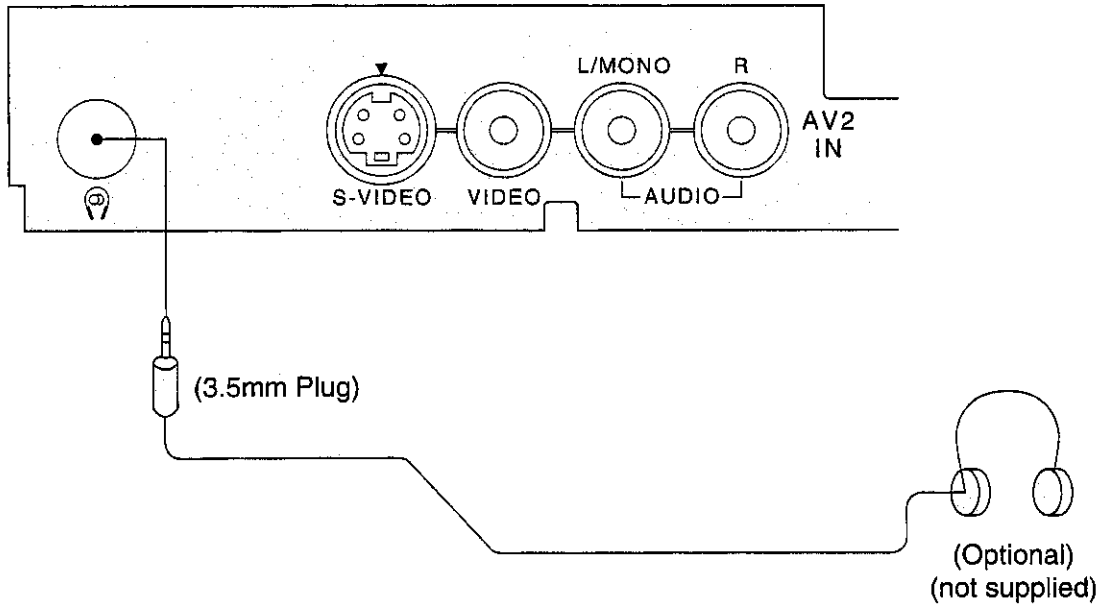









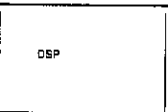

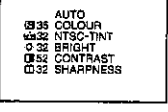

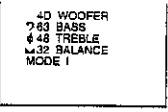
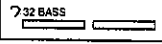
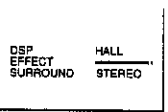
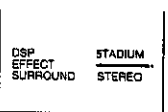



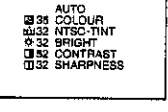

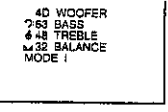
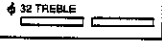
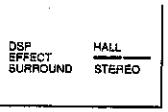
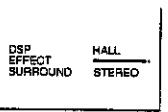

Connecting Headphones (For TC-29GF80R, TC-29GF82G, TC-29GF82H)

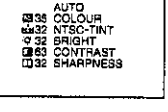
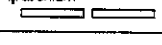
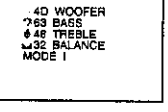
Connect headphones as follows.

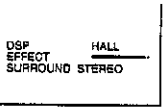
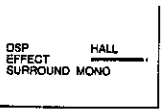



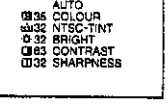
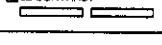
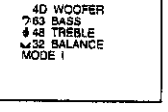
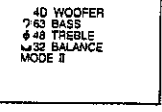

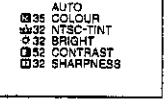
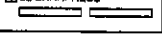











When a Headphones plug is inserted into the Headphones socket all speakers will be automatically disconnected; only the Main Headphones will function.



When the MAIN MENU button is pushed at the MAIN MENU screen, return to the normal viewing condition.
 When the MAIN MENU button is pushed at each MENU screen (PICTURE, SOUND, DSP, FEATURE, LANGUAGE, PRESET, TEXT), return to the MAIN MENU screen.

Push			
Select			
Symbol.Mark			
On-Screen Indication			
Push			
On-Screen Indication (example)	 	 	 
			
	 	 	 
			
	 	 	 
			
	 	 	
			
	 		

The TEXT MENU screen appears only for TX-29GF85T, TX-33GF85T and TX-33GF85X

 FEATURES	 LANGUAGE ENGLISH 中国话	 PRESET	 TEXT
<div data-bbox="44 792 213 887"> BLUE BACK ON VCR/GAME OFF P-DE ON GAME MODE AV2 CH COLOUR SET OFF PIP SIZE 1/16 STILL RANGE LONG </div> <div data-bbox="108 913 146 958">  </div> <div data-bbox="44 981 213 1075"> BLUE BACK ON VCR/GAME OFF P-DE ON GAME MODE AV2 CH COLOUR SET OFF PIP SIZE 1/16 STILL RANGE LONG </div> <div data-bbox="108 1102 146 1146">  </div> <div data-bbox="44 1169 213 1263"> BLUE BACK ON VCR/GAME OFF P-DE ON GAME MODE AV2 CH COLOUR SET OFF PIP SIZE 1/16 STILL RANGE LONG </div> <div data-bbox="108 1290 146 1335">  </div> <div data-bbox="44 1357 213 1451"> BLUE BACK ON VCR/GAME OFF P-DE ON GAME MODE AV2 CH COLOUR SET OFF PIP SIZE 1/16 STILL RANGE LONG </div> <div data-bbox="108 1478 146 1523">  </div> <div data-bbox="44 1545 213 1639"> BLUE BACK ON VCR/GAME OFF P-DE ON GAME MODE AV2 CH COLOUR SET OFF PIP SIZE 1/16 STILL RANGE LONG </div> <div data-bbox="108 1666 146 1711">  </div> <div data-bbox="44 1733 213 1827"> BLUE BACK ON VCR/GAME OFF P-DE ON GAME MODE AV2 CH COLOUR SET OFF PIP SIZE 1/16 STILL RANGE LONG </div> <div data-bbox="108 1854 146 1899">  </div> <div data-bbox="44 1921 213 2016"> BLUE BACK ON VCR/GAME OFF P-DE ON GAME MODE AV2 CH COLOUR SET OFF PIP SIZE 1/16 STILL RANGE LONG </div>	<div data-bbox="405 792 574 887"> LANGUAGE ENGLISH 中国话 </div> <div data-bbox="469 913 507 958">  </div> <div data-bbox="405 981 574 1075"> 中国话 ENGLISH 中国话 </div>	<div data-bbox="772 792 941 887"> CH1 PRESET CH SELECT DIRECT SYS SELECT CHINA AUTO TUNE MANUAL TUNE SOUND SYS 6.5MHz COLOUR SYS AUTO FINE TUNE SKIP OFF </div> <div data-bbox="836 913 874 958">  </div> <div data-bbox="772 981 941 1075"> CH1 PRESET CH SELECT DIRECT SYS SELECT CHINA AUTO TUNE MANUAL TUNE SOUND SYS 6.5MHz COLOUR SYS AUTO FINE TUNE SKIP OFF </div> <div data-bbox="836 1102 874 1146">  </div> <div data-bbox="772 1169 941 1263"> CH1 PRESET CH SELECT DIRECT SYS SELECT CHINA AUTO TUNE MANUAL TUNE SOUND SYS 6.5MHz COLOUR SYS AUTO FINE TUNE SKIP OFF </div> <div data-bbox="836 1290 874 1335">  </div> <div data-bbox="772 1357 941 1451"> CH1 PRESET CH SELECT DIRECT SYS SELECT CHINA AUTO TUNE MANUAL TUNE SOUND SYS 6.5MHz COLOUR SYS AUTO FINE TUNE SKIP OFF </div> <div data-bbox="836 1478 874 1523">  </div> <div data-bbox="772 1545 941 1639"> CH1 PRESET CH SELECT DIRECT SYS SELECT CHINA AUTO TUNE MANUAL TUNE SOUND SYS 6.5MHz COLOUR SYS AUTO FINE TUNE SKIP OFF </div> <div data-bbox="836 1666 874 1711">  </div> <div data-bbox="772 1733 941 1827"> CH1 PRESET CH SELECT DIRECT SYS SELECT CHINA AUTO TUNE MANUAL TUNE SOUND SYS 6.5MHz COLOUR SYS AUTO FINE TUNE SKIP OFF </div> <div data-bbox="836 1854 874 1899">  </div> <div data-bbox="772 1921 941 2016"> CH1 PRESET CH SELECT DIRECT SYS SELECT CHINA AUTO TUNE MANUAL TUNE SOUND SYS 6.5MHz COLOUR SYS AUTO FINE TUNE SKIP OFF </div>	<div data-bbox="1129 792 1299 887"> DISPLAY CANCEL LIST STORE TEXT MODE FAST </div> <div data-bbox="1193 913 1232 958">  </div> <div data-bbox="1129 981 1299 1075"> DISPLAY CANCEL LIST STORE TEXT MODE FAST </div> <div data-bbox="1193 1102 1232 1146">  </div> <div data-bbox="1129 1169 1299 1263"> DISPLAY CANCEL LIST STORE TEXT MODE FAST </div>

Tuning Procedure

Channel Selection

Select the most easily viewed channel selection method.

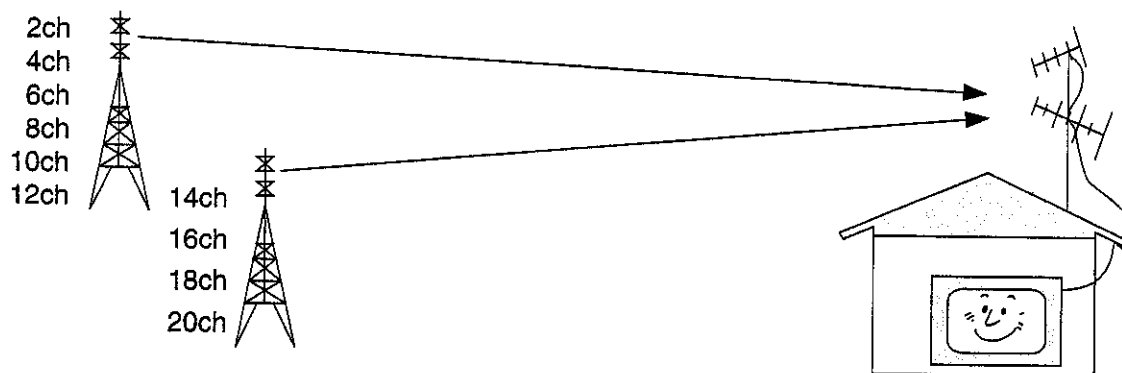

Example

Programme Number	Channel Display	Received Channel
1	2	2
2	4	4
3	6	6
4	8	8
5	10	10
6	12	12
7	14	14
8	16	16
9	18	18
10	20	20

POSITION SELECT

When the Channel Selection is on POS. (Position), and Auto Search is performed, the unit memories the channels searched in order from Programme No.1.

- Push the button ① to view channel 2.
- Push the button ② to view channel 4.
- Push the button ③ to view channel 6.

During Position mode various reception channels can be viewed.

Example

Programme Number	Channel Display	Received Channel
1	—	—
2	2	2
3	—	—
4	4	4
5	—	—
6	6	6
7	—	—
8	8	8
9	—	—
10	10	10
⋮	⋮	⋮
20	20	20
⋮	⋮	⋮

DIRECT SELECT

When the Channel Selection is on DIRECT, and Auto Search is performed, the unit memories the programme number which is the same as the channel searched.

This method allows you to select the desired channel by pushing the channel display number directly on the remote control to select the station. The channel display numbers for the broadcast stations in each country are listed on Page 23.

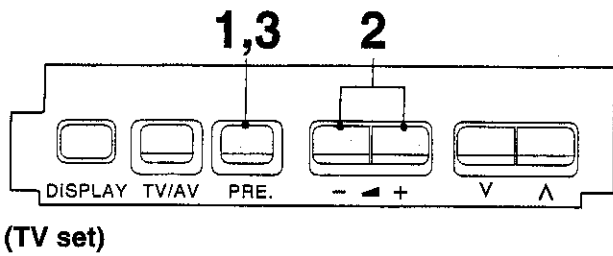

(Remote Control)

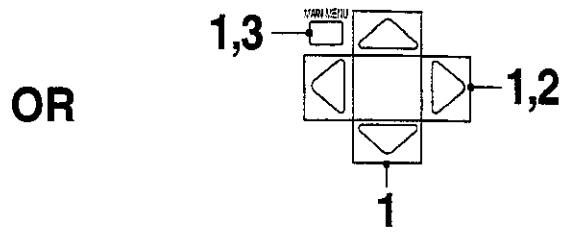

Before Country System Selection and AUTO SEARCH tuning, set the "CHANNEL SELECT" mode, as detailed below.

1 Push the "PRE." (PRESET) Button, setting the Preset Menu to "CH SELECT".

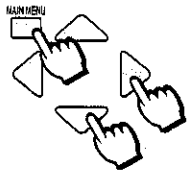

Push the "MAIN MENU" and "Position" Buttons, until the Preset Menu to "CH SELECT". (Refer to page 19)

1	PRESET
CH 1	
CH SELECT	DIRECT
SYS SELECT	CHINA
AUTO TUNE	
MANUAL TUNE	
SOUND SYS	6.5MHz
COLOUR SYS	AUTO
FINE TUNE	
SKIP	OFF

"CH SELECT" Condition.

2 Select the "CH SELECT (Channel Select)" Mode by pushing the Volume Up "+" or Down "-" Button.

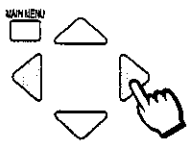

Select the "CH SELECT (Channel Select)" Mode by pushing the Position Left "<" or Right ">" Button.

1	PRESET
CH 1	
CH SELECT	DIRECT
SYS SELECT	CHINA
AUTO TUNE	
MANUAL TUNE	
SOUND SYS	6.5MHz
COLOUR SYS	AUTO
FINE TUNE	
SKIP	OFF

Setting range when the "POS." (Position) has been selected: Position 0-99
Setting range when the "DIRECT" has been selected: Channel 1-125

The channel select indicator will change as follows.
DIRECT ↔ POS.

3 Push the "PRE." (PRESET) Button 8 times.



This returns the set to the normal viewing condition.



Push the "MAIN MENU" Button twice.

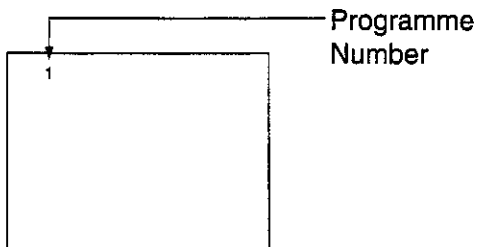

Country System Selection

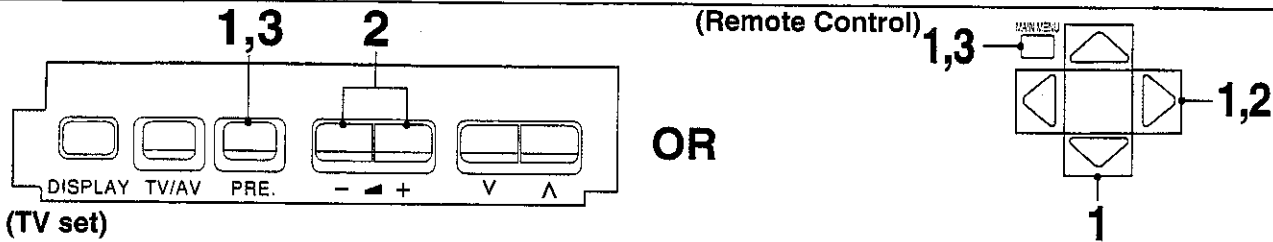

Before AUTO SEARCH tuning and MANUAL SEARCH tuning, set the "SYSTEM SELECT" mode, as detailed below.

1 Push the "PRE." (PRESET) Button twice, setting the Preset Menu to "SYS SELECT".

Push the "MAIN MENU" and "Position" Buttons, until the Preset Menu to "SYS SELECT". (Refer to page 19)

1	PRESET
CH 1	
CH SELECT	DIRECT
SYS SELECT	CHINA
AUTO TUNE	
MANUAL TUNE	
SOUND SYS	6.5MHz
COLOUR SYS	AUTO
FINE TUNE	
SKIP	OFF

"SYS SELECT" Condition.

2 Select the appropriate System by pushing the Volume Up "+" or Down "-" Button.

Select the appropriate System by pushing the Position Left "<" or Right ">" Button.

1	PRESET
CH 1	
CH SELECT	DIRECT
SYS SELECT	CHINA
AUTO TUNE	
MANUAL TUNE	
SOUND SYS	6.5MHz
COLOUR SYS	AUTO
FINE TUNE	
SKIP	OFF

The system select indicator will change as follows.

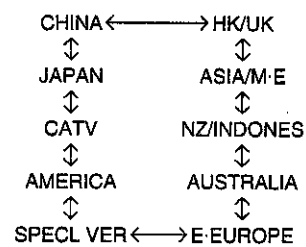

3 Push the "PRE." (PRESET) Button 7 times.

Push the "MAIN MENU" Button twice.

1	
---	--

This returns the set to the normal viewing condition.

System Select by Country

SYSTEM SELECT	COUNTRY
CHINA	China
HK/UK	Hong Kong, United Kingdom
ASIA/M-E	Malaysia, Singapore, Thailand, Asia countries, Kuwait, Saudi Arabia, United Arab Emirates, Middle East countries, etc.
NZ/INDONES	New Zealand, Indonesia, etc.
AUSTRALIA	Australia
E-EUROPE	CIS, Poland, etc.
SPECL VER	South Africa
AMERICA	U.S.A., Chile, Mexico, Panama, Peru, Philippines, Taiwan, Venezuela, etc.
CATV	USA CATV
JAPAN	Japan

Channel Allocation

- CATV (USA CATV) channel numbers as recommended by the joint EIA/NCTA Engineering committee and published as EIA INTERIM STANDARD No.6-CABLE TELEVISION CHANNEL IDENTIFICATION PLAN-MAY 1983.
- The receiving channels are as follows;

SYS SELECT	CHINA	HK/UK	ASIA/M•E	NZ/INDONES	AUSTRALIA	E•EUROPE	SPECL VER	AMERICA	CATV	JAPAN
CH DISPLAY	RECEIVE CHANNEL									
0	-	-	-	-	0	-	-	-	-	-
1	1	-	-	1	1	1	1	-	1	1
2	2	-	2	2	2	2	2	2	2	2
11	11	-	11	11	11	11	11	11	11	11
12	12	-	12	-	12	12	12	12	12	12
13	13	-	-	-	-	-	13	13	13	13
14	14	-	-	-	-	-	-	14	-	-
20	-	-	-	-	-	-	-	-	-	-
21	-	21	21	21	-	21	21	-	-	-
28	-	-	-	-	28	-	-	-	-	-
57	57	-	-	-	-	-	-	-	-	-
58	-	-	-	-	-	-	-	-	-	-
62	-	62	62	62	62	62	62	62	62	62
63	-	63	63	63	63	63	63	63	63	C13
69	-	69	69	69	69	69	69	69	-	-
70	-	-	-	-	-	-	-	-	-	-
73	-	-	-	-	-	-	-	-	-	-
74	-	S'1	S'1	S'1	-	S'1	S'1	-	-	-
75	-	S'2	S'2	S'2	-	-	S'2	-	-	-
76	-	S'3	S'3	S'3	-	-	S'3	-	-	-
77	-	-	-	-	-	-	-	-	-	-
78	-	-	-	-	-	-	-	-	-	-
79	-	-	-	-	-	-	-	-	-	-
80	-	S1	S1	S1	-	S1	S1	-	-	-
81	Z1	S2	S2	S2	-	S2	S2	-	-	-
89	Z9	S10	S10	S10	-	S10	S10	-	-	-
90	Z10	S11	S11	S11	5A	S11	-	-	-	-
91	Z11	S12	S12	S12	9A	S12	-	-	-	-
92	Z12	S13	S13	S13	-	S13	-	-	-	-
93	Z13	S14	S14	S14	-	S14	S14	-	-	-
94	Z14	S15	S15	S15	-	S15	S15	-	-	-
95	Z15	S16	S16	S16	-	S16	S16	-	-	-
96	Z16	S17	S17	S17	-	S17	S17	-	-	-
97	Z17	S18	S18	S18	-	S18	S18	-	-	-
98	Z18	S19	S19	S19	-	S19	S19	-	-	-
99	Z19	S20	S20	S20	-	S20	S20	-	99	C49
100	Z20	S21	S21	S21	-	S21	S21	-	100	-
117	Z37	-	-	-	-	-	-	-	-	-
120	-	S41	S41	S41	-	S41	S41	-	-	-
125	-	-	-	-	-	-	-	-	125	-

Automatic Tune (Channel Select and Country System must already be set; Refer to pages 20 to 23)

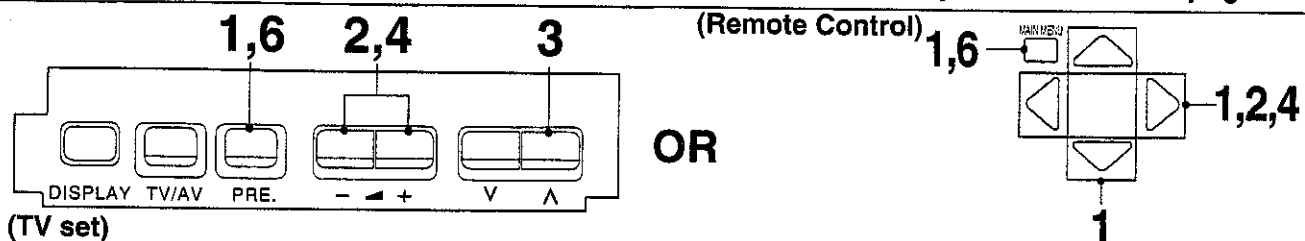

This TV uses automatic tuning to determine whether or not a broadcast signal is being sent which it can receive, and automatically prepares so that the channel selection can respond to both the position select and direct select modes.

- 1** Push the "PRE." (PRESET) Button 3 times.
- Push the "MAIN MENU" and "Position" Buttons, until the Preset Menu to "AUTO TUNE".

```

1 PRESET
CH 1
CH SELECT DIRECT
SYS SELECT CHINA
AUTO TUNE
MANUAL TUNE
SOUND SYS 6.5MHz
COLOUR SYS AUTO
FINE TUNE
SKIP OFF
    
```

Automatic Search "AUTO TUNE" Condition.

- 2** Push the Volume Up "+" or Down "-" Button.
- Push the Position Left "<" or Right ">" Button.

```

1
CH 1

AUTO TUNE
    
```

Search Start.

The best tuning position is automatically memorized.

- 3** After all stations are tuned, the on-screen display will automatically change from "AUTO TUNE" to "SOUND SYS" Position. Confirm the sound condition of each Programme Number by using the Programme Number Up "^" Button.

```

2 PRESET
CH 2
CH SELECT DIRECT
SYS SELECT CHINA
AUTO TUNE
MANUAL TUNE
SOUND SYS 6.5MHz
COLOUR SYS AUTO
FINE TUNE
SKIP OFF
    
```

If the Sound is not clear or no sound is produced on a Programme Number, then follow the next Step 4.

Note: When sound volume is too small to confirm, turn it up by using the sound volume button on the remote control.

- 4** If necessary, push the Volume Up "+" or Down "-" Button, to improve the Sound quality.
- If necessary, push the Position Left "<" or Right ">" Button to improve the Sound quality.

```

2 PRESET
CH 2
CH SELECT DIRECT
SYS SELECT CHINA
AUTO TUNE
MANUAL TUNE
SOUND SYS 6.5MHz
COLOUR SYS AUTO
FINE TUNE
SKIP OFF
    
```

The sound indicator will change as follows.

→ 4.5MHz ↔ 5.5MHz ←
 → 6.5MHz ↔ 6.0MHz ←

5  Use the Programme Number Up “^” button to sequentially check each station. If necessary, repeat step 3 to 4 for each Programme Number.

6  After all stations are tuned, push the “PRE.” (PRESET) Button 4 times.

 After all stations are tuned, push the “MAIN MENU” Button twice.

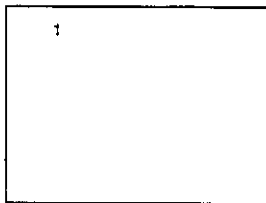

This returns the set to the normal viewing condition. Programme Number memory locations.

 **Helpful Hint**

- (1) If a clear picture with correct colours cannot be obtained when a Broadcast or AV signal is received, refer to the “Colour System Selection” operation on page 35.
- (2) After the Automatic Search is finished, push the Programme Number “Up” Button to confirm the tuning condition for each Programme Number. If some Programme Numbers are unused, it is possible to skip such Programme Numbers. Please refer to the Programme Number Skip operation on page 30.
- (3) Repeated pushing of the “PRE.” (PRESET) button changes the Preset Menu as follows;

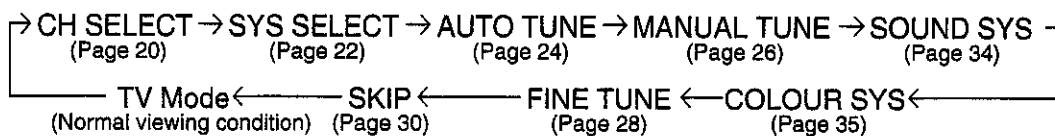

Manual Tune (Channel Select and Country System must already be set; Refer to pages 20 to 23)

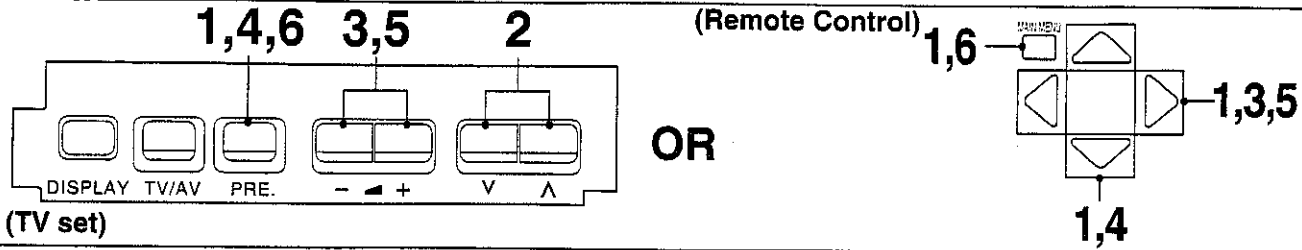

1

Push the "PRE." (PRESET) Button 4 times.

Push the "MAIN MENU" and "Position" Buttons, until the Preset Menu to "MANUAL TUNE".

1	PRESET
CH 1	CH SELECT DIRECT
	SYS SELECT CHINA
	AUTO TUNE
	MANUAL TUNE
	SOUND SYS 6.5MHz
	COLOUR SYS AUTO
	FINE TUNE
	SKIP OFF

Manual Search "MANUAL TUNE" Condition.

2

Push either the Programme Number Up "∧" or Down "∨" Button.

2	PRESET
CH 2	CH SELECT DIRECT
	SYS SELECT CHINA
	AUTO TUNE
	MANUAL TUNE
	SOUND SYS 6.5MHz
	COLOUR SYS AUTO
	FINE TUNE
	SKIP OFF

Select the desired Programme Number.

3

Push the Volume Up "+" or Down "-" Button.

Volume "+": Next higher Channel

Volume "-": Next lower Channel

2	CH 2
	MANUAL TUNE

↓

Search Start.

Push the Position Left "<" or Right ">" Button.

Position ">": Next higher Channel

Position "<": Next lower Channel

2	PRESET
CH 2	CH SELECT DIRECT
	SYS SELECT CHINA
	AUTO TUNE
	MANUAL TUNE
	SOUND SYS 6.5MHz
	COLOUR SYS AUTO
	FINE TUNE
	SKIP OFF

The best tuning position is automatically memorized.

4

Push the "PRE." (PRESET) Button.

Push the Position Down "∨" Button.

2	PRESET
CH 2	CH SELECT DIRECT
	SYS SELECT CHINA
	AUTO TUNE
	MANUAL TUNE
	SOUND SYS 6.5MHz
	COLOUR SYS AUTO
	FINE TUNE
	SKIP OFF

"SOUND SYS" Condition.

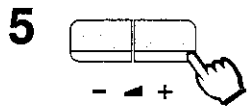

If the sound is not clear or no sound is produced on a Programme Number Position, push the Volume Up “+” or Down “-” Button.

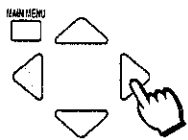

If the sound is not clear or no sound is produced on a Programme Number Position, push the Position Left “<” or Right “>” Button.

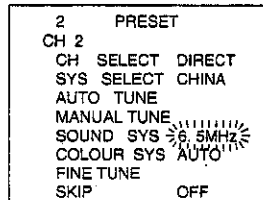

You may improve the Sound quality.

The sound indicator will change as follows.

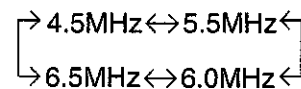

Note:

When sound volume is too small to confirm, turn it up by using the sound volume button on the remote control.

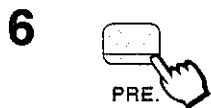

Push the “PRE.” (PRESET) Button 4 times.



Push the “MAIN MENU” Button twice.

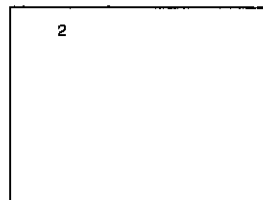

This returns the set to the normal viewing condition.

Helpful Hint

- (1) If a clear picture cannot be obtained even when a Broadcast or AV signal is received, refer to the “Colour System Selection” operation on page 35.
- (2) After the Manual Search is finished, push the Programme Number “Up” Button to confirm the tuning condition for each Programme Number. If Programme Numbers are unused, it is possible to skip such Programme Numbers. Please refer to the Programme Number skip operation on page 30.
- (3) When using VCR without video and audio input/output terminals for, it is convenient to connect the aerial cable as indicated in the instruction manual of VCR and to set the designated channel to programme No. “0”. In that case, perform manual search after setting the colour system and sound system in advance. Further, in multi-system VCR, it is much convenient to set the designated channel to several programme Numbers.

Fine Tuning

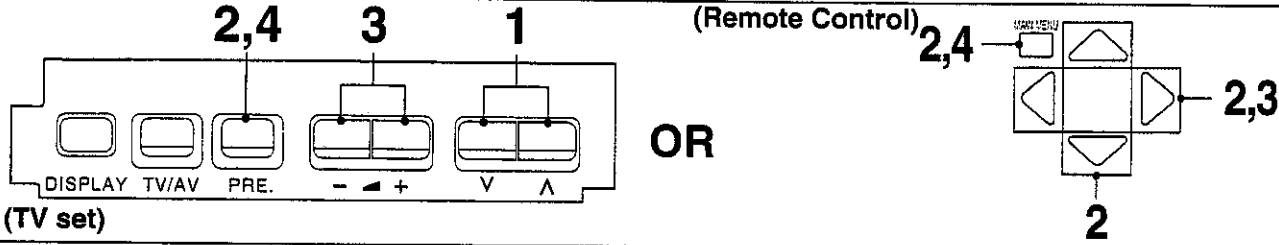

Under normal reception conditions this function is not required or necessary. However, in areas of poor reception or constant interference, a slight adjustment of the tuning may improve the picture and sound quality.

1

Select the channel which you want to improve, using the Programme Number Up “^” or Down “v” Button.

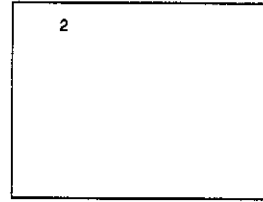

Select the desired Programme Number.

2

Push the “PRE.” (PRESET) Button 7 times, setting the Preset menu to “FINE TUNE”.

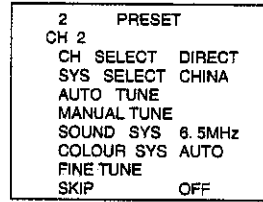

Fine Tune Condition.

Push the “MAIN MENU” and “Position” Buttons, until the Preset Menu to “FINE TUNE”.

3

Push and hold the Volume Up “+” or Down “-” Button until the clear picture is received.

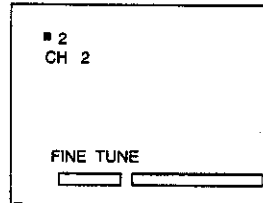

Fine Tune Start.

Push and hold the Position Left “<” or Right “>” Button, until the clear picture is received.

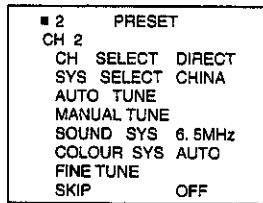

The AFC function is deactivated. The “■” symbol appears to the left of the Programme Number.

4

Push the “PRE.” (PRESET) Button twice.

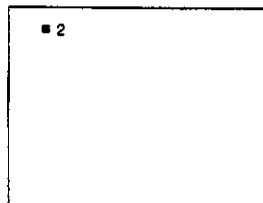

This returns the set to the normal viewing condition.

Push the “MAIN MENU” Button twice.

How to Cancel the Fine Tuning

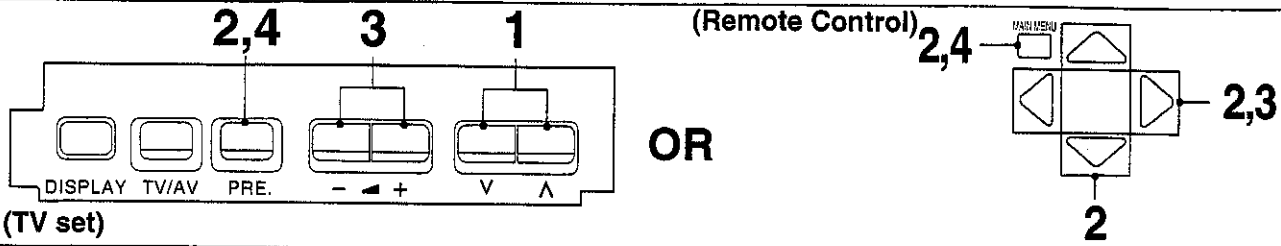

Cancelling previously adjusted (manually) fine tuning, means re-activating the AFC (Automatic Frequency Control) Function, also known as AFT (Automatic Fine Tuning). Re-activating the Automatic Fine Tuning means alamping the set to automatically tune to the optimum tuning position, for that programme Number.

1

Select the "AFC OFF" Programme Number which you want to return to Automatic Frequency Control (cancel the manual fine tuning).

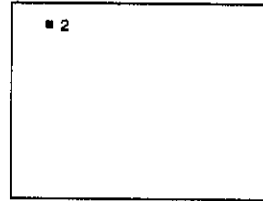

"AFC OFF" Programme Numbers are indicated to you by the "■" symbol to the left of the Programme Numbers in the On-Screen Display.

2

Push the "PRE." (PRESET) Button 4 times, setting the Preset menu to "MANUAL TUNE".

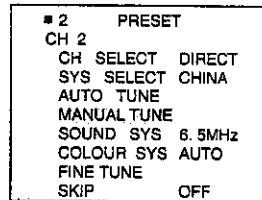

Manual Search Condition.

Push the "MAIN MENU" and "Position" Buttons, until the Preset Menu to "MANUAL TUNE".

3

Push the Volume Up "+" or Down "-" Button, briefly.

Push the Position Left "<" or Right ">" Button, briefly.

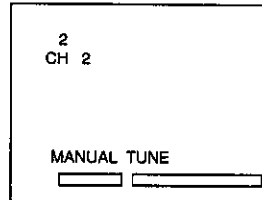

The best tuning position is automatically memorized. (In other words, manually tune away from the transmission, and then back to it.)

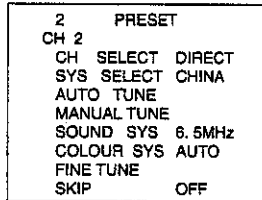

4

Push the "PRE." (PRESET) Button 5 times.

Push the "MAIN MENU" Button twice.

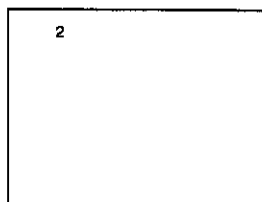

This returns the set to the normal viewing condition.

Programme Number Skip

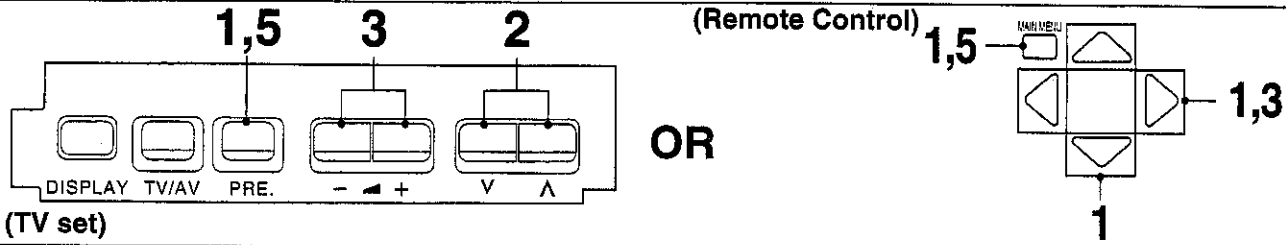

It is possible to skip Programme Numbers on which no TV stations are tuned appearing on the screen. The function is only effective when selecting Programme Numbers by pushing the Programme Number Up or Down Buttons either on the TV set or the Remote control.

1 Push the "PRE." (PRESET) Button 8 times, setting the Preset menu to "SKIP".

```

1 PRESET
CH 1
CH SELECT DIRECT
SYS SELECT CHINA
AUTO TUNE
MANUAL TUNE
SOUND SYS 6.5MHz
COLOUR SYS AUTO
FINE TUNE
SKIP OFF
    
```

Channel Skip Condition.

Push the "MAIN MENU" and "Position" Buttons, until the Preset Menu to "SKIP".

2 Select a Programme Number you want to skip by pushing the Programme Number Up "^" or Down "v" Button.

```

2 PRESET
CH 2
CH SELECT DIRECT
SYS SELECT CHINA
AUTO TUNE
MANUAL TUNE
SOUND SYS 6.5MHz
COLOUR SYS AUTO
FINE TUNE
SKIP OFF
    
```

3 Push the Volume Up "+" or Down "-" Button.

```

2 PRESET
CH 2
CH SELECT DIRECT
SYS SELECT CHINA
AUTO TUNE
MANUAL TUNE
SOUND SYS 6.5MHz
COLOUR SYS AUTO
FINE TUNE
SKIP ON
    
```

The displayed "OFF" condition changes to "ON".

Push the Position Left "<" or Right ">" Button.

4 Repeat Steps 2 and 3 for the remaining Programme Numbers for which the Skip function is desired.

5 After the Skip Operation is completed, push the "PRE." (PRESET) Button (once).

```

2
    
```

This returns the set to the normal viewing condition.

After the Skip Operation is completed, push the "MAIN MENU" Button twice.

How to Cancel the Skip Function

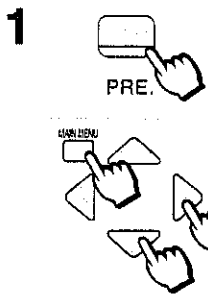
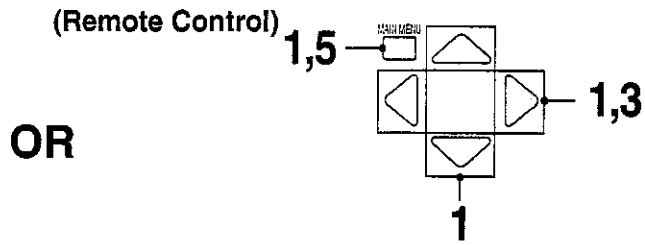
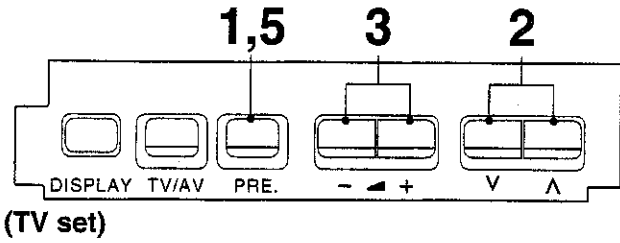

1 Push the "PRE." (PRESET) Button 8 times, setting the Preset menu to "SKIP".

Push the "MAIN MENU" and "Position" Buttons, until the Preset Menu to "SKIP".

```

1 PRESET
CH 1
CH SELECT DIRECT
SYS SELECT CHINA
AUTO TUNE
MANUAL TUNE
SOUND SYS 6.5MHz
COLOUR SYS AUTO
FINE TUNE
SKIP OFF
    
```

Channel Skip Condition.

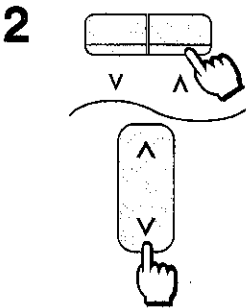

2 Select a skipped Programme Number, by pushing the Programme Number Up "^" or Down "v" Button.

```

2 PRESET
CH 2
CH SELECT DIRECT
SYS SELECT CHINA
AUTO TUNE
MANUAL TUNE
SOUND SYS 6.5MHz
COLOUR SYS AUTO
FINE TUNE
SKIP ON
    
```

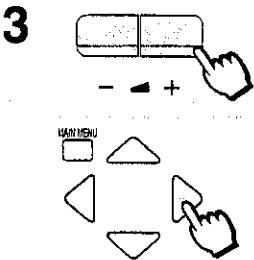

3 Push the Volume Up "+" or Down "-" Button.

Push the Position Left "<" or Right ">" Button.

```

2 PRESET
CH 2
CH SELECT DIRECT
SYS SELECT CHINA
AUTO TUNE
MANUAL TUNE
SOUND SYS 6.5MHz
COLOUR SYS AUTO
FINE TUNE
SKIP OFF
    
```

The displayed "ON" condition changes to "OFF".



4 Repeat Steps 2 and 3, if you wish to cancel the skip function on any other Programme Number.

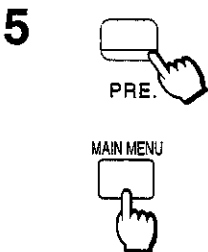

5 After the Skip Cancel Operation is completed, push the "PRE." (PRESET) Button (once).

After the Skip Cancel Operation is completed, push the "MAIN MENU" Button twice.

```

2
    
```

This returns the set to the normal viewing condition.

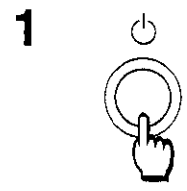
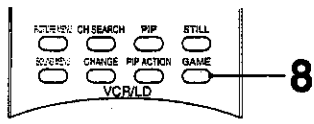
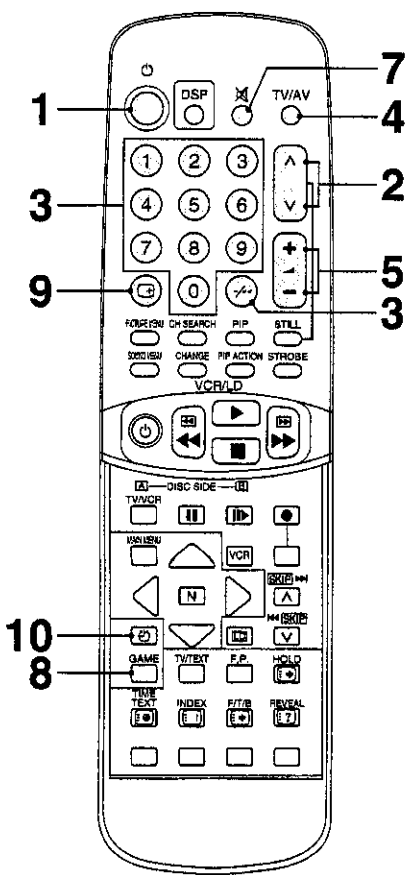
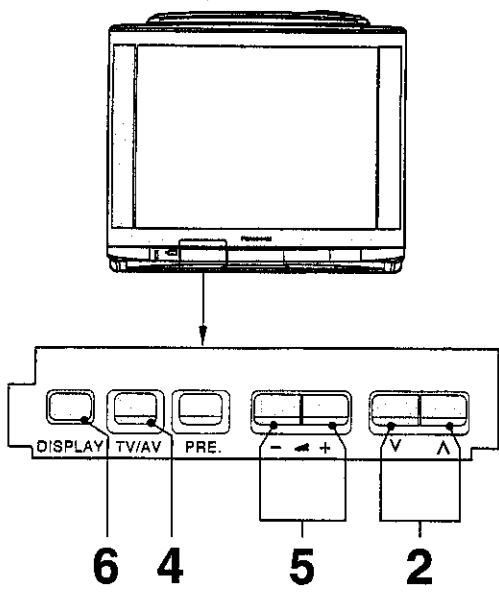

How to switch the power ON or OFF
 The TV set must first be switched on at the wall outlet and at the Power Switch. (Refer to page 9)
 Push this button to turn the TV set ON, from STANDBY mode.
 Push it again to turn the TV set OFF, STANDBY mode.

Note:
 It is also possible to turn the TV set on STANDBY by pushing the "Direct Programme Number Selection" Buttons (0-9) and the "Programme Number Up or Down" Button, either on the set or on the Remote Control.

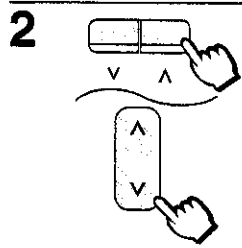

Programme Number Selection
 Push the Programme Number Up "A" or Down "V" Button to select the next higher or lower Programme number.

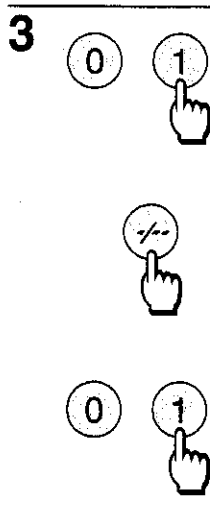

Direct Programme Number Selection (CH SELECT = POS.)
 You can select the numbers directly by pushing "Number 0 - 9" button and the two digit Numbers by pushing "Two Digit" and "Programme Number" buttons.

Programme Number 8..... 8
 Programme Number 12..... /, 1, 2

Direct Programme Number Selection (CH SELECT = DIRECT)
 You can select the number directly by pushing the corresponding programme number button.

Programme Number 8..... 8
 Programme Number 36..... 3, 6
 Programme Number 124.... 1, 2, 4

Note:
 When the Skip setting for Programme Number 100 through 125 is on, the channel selection time will be shorted, and thus you can not input three digits at a time.

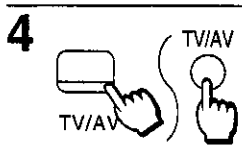

TV/AV Mode Selection
 Push the "TV/AV" Button to select TV, AV1, AV2, AV3 input signal modes sequentially.

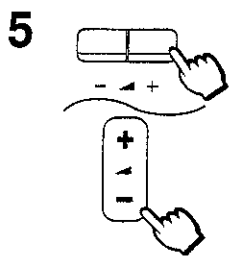

5 Volume Adjustment

Push the Volume Up "+" or Down "-" Button to increase or decrease the sound volume level.

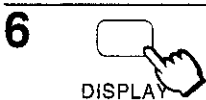
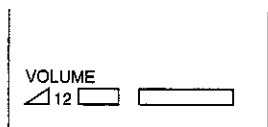

6 Display Button

By pushing the Display button various demonstrations and on-screen displays will appear. Push the Display button a second time to halt the display/demonstration mode, and return the set to the normal viewing condition.

Note:

When this button is pushed, the Picture and Sound Menus change to Picture (AUTO) and Sound (4D WOOFER).

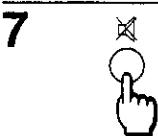

7 Mute Button

Push this button to mute the sound completely. The "Mute" symbol will appear. (colour change to Red)

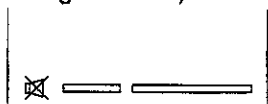

Push the button once again to restore the previous sound level, and cancel the mute.

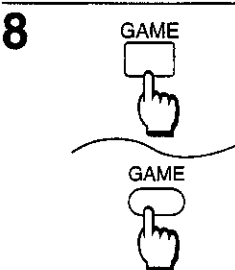

8 GAME Button

This button provides a convenient switching feature. Push this button when playing a game to switch to the AV mode set in the Game mode (refer to page 42), and the picture and sound Menus set for the game are displayed.

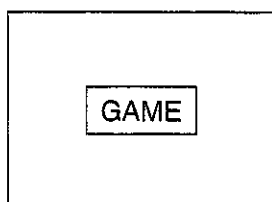

Push again to cancel.



9 Recall Button

Push the "Recall" Button to display the current system status. Push again to cancel.

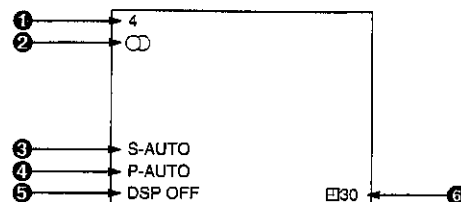

- 1 Programme Number (Refer to page 32)
- 2 Audio Mode (Refer to page 37)
- 3 Sound Menu (Refer to page 39)
- 4 Picture Menu (Refer to page 38)
- 5 Surround Mode (Refer to page 36)
- 6 OFF Timer (Refer to page 33)

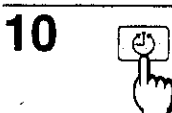

10 Off Timer Button

The TV set may be preset to switch to stand-by after a fixed period. By pushing "OFF-Timer" Button, you can select the preset time; either "30", "60", "90" minutes or AUTO Mode.

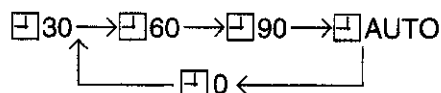

Setting Off-Timer to AUTO mode. If the set is not switched off when the TV station stops broadcasting, it will automatically go to Stand-by Mode after 5 minutes.

Note:

Off-Timer setting will not operate in AUTO mode when the Television set is in AV Mode.

Sound System Selection (Different countries use differing systems)

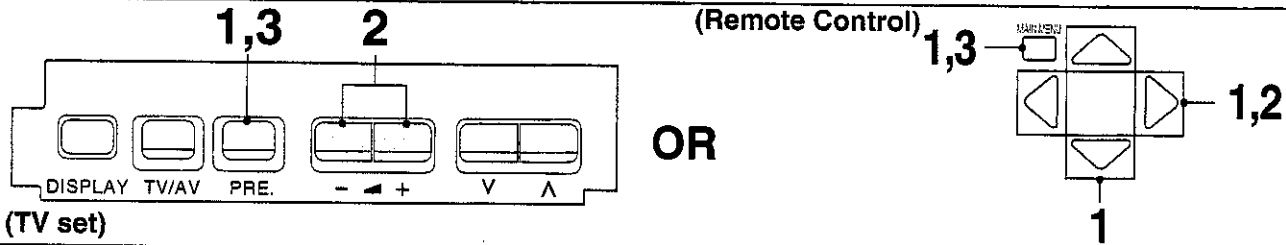

This function is used only in the TV mode, and is not applicable in AV Mode when the sound is not clear or no sound is produced on a Programme Number.

1

Push the "PRE." (PRESET) Button 5 times.

Push the "MAIN MENU" and "Position" Buttons, until the Preset Menu to "SOUND SYS".

```

1 PRESET
CH 1
CH SELECT DIRECT
SYS SELECT CHINA
AUTO TUNE
MANUAL TUNE
SOUND SYS 6.5MHz
COLOUR SYS AUTO
FINE TUNE
SKIP OFF
    
```

Sound System Condition.

2

Push the Volume Up "+" or Down "-" Button repeatedly until the optimum sound is obtained.

Push the Position Left "<" or Right ">" Button repeatedly until the optimum sound is obtained.

```

1 PRESET
CH 1
CH SELECT DIRECT
SYS SELECT CHINA
AUTO TUNE
MANUAL TUNE
SOUND SYS 6.5MHz
COLOUR SYS AUTO
FINE TUNE
SKIP OFF
    
```

The sound system will change as shown.

4.5MHz ↔ 5.5MHz
 ↓ ↑
 6.5MHz ↔ 6.0MHz

Note:
 These are different sound broadcast transmission systems applicable to differing countries.

3

Push the "PRE." (PRESET) Button 4 times.

Push the "MAIN MENU" Button twice.

```

1
    
```

This returns the set to the normal viewing condition.

The selected Sound System is automatically memorised.

Colour System Selection (Different countries use differing systems)

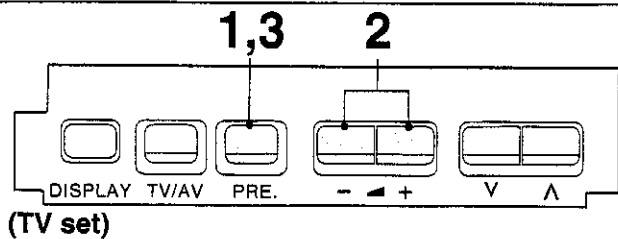

(Remote Control)

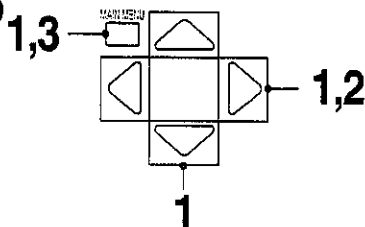

OR

If a clear picture with current colours cannot be obtained when a Broadcast or AV signal is received.

1 Push the "PRE." (PRESET) Button 6 times.

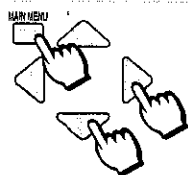

Push the "MAIN MENU" and "Position" Buttons, until the Preset Menu to "COLOUR SYS".

1	PRESET
CH 1	
CH SELECT	DIRECT
SYS SELECT	CHINA
AUTO TUNE	
MANUAL TUNE	
SOUND SYS	8.5MHz
COLOUR SYS	AUTO
FINE TUNE	
SKIP	OFF

Colour System Condition.

2 Push the Volume Up "+" or Down "-" Button repeatedly until the optimum image is produced.

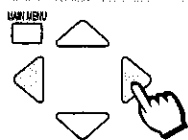
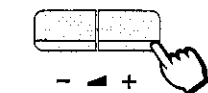

Push the Position Left "<" or Right ">" Button repeatedly until the optimum image is produced.

1	PRESET
CH 1	
CH SELECT	DIRECT
SYS SELECT	CHINA
AUTO TUNE	
MANUAL TUNE	
SOUND SYS	8.5MHz
COLOUR SYS	PAL
FINE TUNE	
SKIP	OFF

The colour system will change as shown.

AUTO ↔ PAL ↔ SECAM
 ↓ ↑
 NTSC3.58 ↔ NTSC4.43

Note:
 PAL, SECAM and NTSC 3.58 are different colour signal broadcast transmission systems applicable to differing countries. NTSC 4.43 is a trick playback mode used in special VCR's to playback NTSC recorded video tapes through PAL television equipment.

3 Push the "PRE." (PRESET) Button 3 times. (In AV Mode it is only necessary to push the "PRE." (PRESET) button once.)

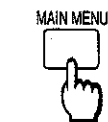

Push the "MAIN MENU" Button twice.

1	
---	--

This returns the set to the normal viewing condition.

The selected Colour System is automatically memorised.

STROBE and DSP (Digital Surround Processor) Operation

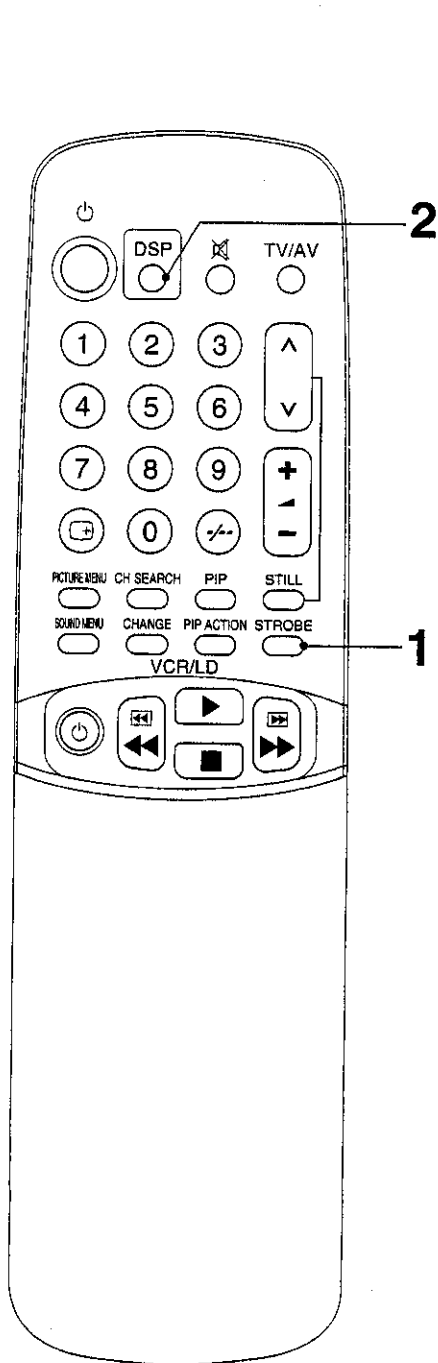

1

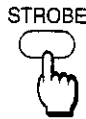

STROBE

(For TX-29GF85T, TC-29GF85G, TX-33GF85T, TX-33GF85X, TC-33GF85G, TC-33GF85H)

Push the "STROBE" button to display the sub-picture with a strobe effect.

When the "STROBE" is on, push the "STROBE" button again to turn off the strobe, or push the "STILL" button to freeze the strobe image.

Push the "STILL" button again to restart the strobe effect.

PIP SIZE IS 1/16

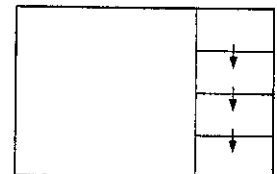
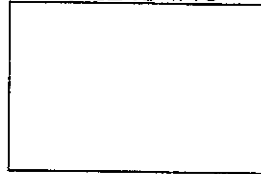

PIP SIZE IS 1/9

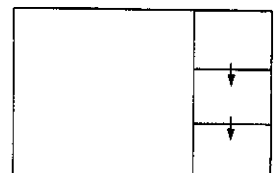

2

DSP



DSP (Digital Surround Processor) Button

By pushing the "DSP" Button, you can sequentially select the DSP (Digital Surround Processor) Mode as shown below.

STADIUM	Allows you to enjoy the sounds of a sports or concert event held in a stadium.
HALL	Provides the same natural echo effects which you hear in a concert hall or music hall.
CINEMA	In this mode sounds are presented in the same manner as in a cinema, allowing for easier listening to both voice and music.
OFF	DSP Mode is OFF.

Note:

If the stereo signal is poor or the receiving conditions are not optimum or if STEREO: MONO automatic switching occurs, it is recommended that "STEREO" switch to MONO (Refer to page 37) be used. If problems or unusual sudden effects are encountered in any of the surround modes, it is recommended that "DSP OFF" be selected.

Stereo Reception (For TC-29GF82G, TC-29GF82H, TC-29GF85G, TX-33GF85X, TC-33GF85G, TC-33GF85H)

Method

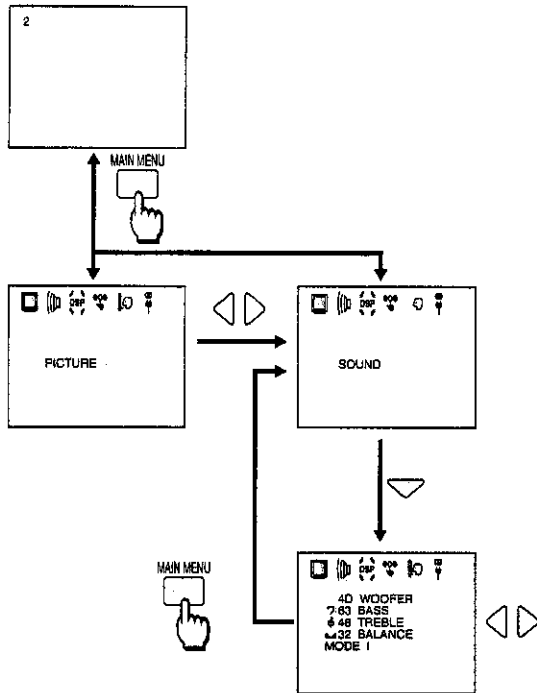

When receive the stereo/bilingual sound system, sound output modes can be selected by pushing as Left figure.

Audio Signal	Mode Indicator
STEREO	∞
MAIN < I >	< I >
SUB < II >	< II >
MONO	▽

	Type of broadcast	Mode Indicator
NICAM	Regular broadcast (Standard Audio)	No Indicator
	Regular + NICAM MONO I (MAIN< I >)	< I > ↔ ▽
	NICAM STEREO	∞ ↔ ▽
	NICAM DUAL MONO (MAIN< I >/SUB< II >)	< I > → < II > ↑ ▽ ↓
A2 (German)	Regular broadcast (Standard Audio)	No Indicator
	BILINGUAL or DUAL MONO: MAIN< I >/SUB< II >	< I > ↔ < II >
	STEREO	∞ ↔ ▽

Note:

- (1) The "A2 (German)" stereo/bilingual TV sound transmission system is used in the following countries; Australia, Malaysia, Thailand, Indonesia, etc.
The "NICAM" stereo TV sound transmission system is used in the following countries; New Zealand, Singapore and Hong Kong.
- (2) If the stereo signal is weak or the receiving conditions are poor or if STEREO: MONO automatic switching occurs, it is recommended to switch to the "Mono" Mode.
When the broadcasting mode changes to "STEREO", "DUAL", or "MONO" after you have selected "MONO" mode, change over to either "STEREO" or "MAIN" Modes will be made automatically.
"DUAL" also known as "BILINGUAL" mode is not currently transmitted in some countries.

Note:

- (1) Even when the contents of the receiving signal undergo changes, selection mode is kept intact.
- (2) When the receiving conditions dereriorate, listening will be easier if the mode is set to the "MONO" position, using the main menu button and position button as above.
- (3) "DUAL", also known as "DUAL MONO" or as "BILINGUAL" is not currently transmitted in some countries.

Picture Menu Operation

1

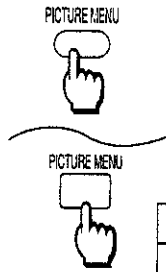

By pushing the "PICTURE MENU" Button, you can sequentially select the Picture Menus as shown below.

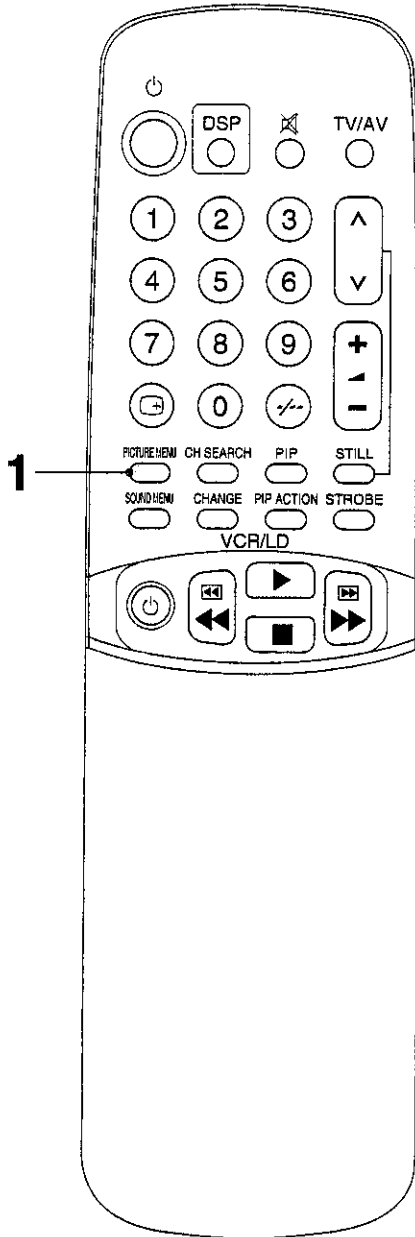

On-Screen	Function
P-AUTO	As the TV video signal is processed for immediate reception, "Brightness", "Contrast", "Tint of colour", etc. are automatically adjusted to the optimum conditions.
P-STANDARD	For watching in normal (evening lighting) environments. This menu selects the normal level of Brightness and Contrast.
P-GAME	Reduces the contrast and sharpness when used in a game mode, and displays a picture which is easy on the eyes.

Helpful Hint

(1) You can change the level of each Function (COLOUR, NTSC-TINT, BRIGHT, CONTRAST, SHARPNESS) for each picture menu.

Please refer to page 40.

(2) Picture menu mode will be memorized for each TV, AV1, AV2, AV3 and GAME mode.

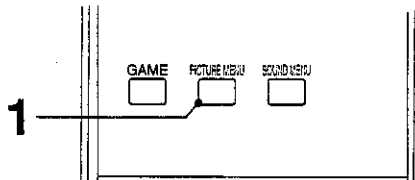

Sound Menu Operation

1

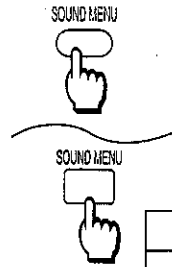

By pushing the "SOUND MENU" Button, you can sequentially select the Sound Menus as shown below.

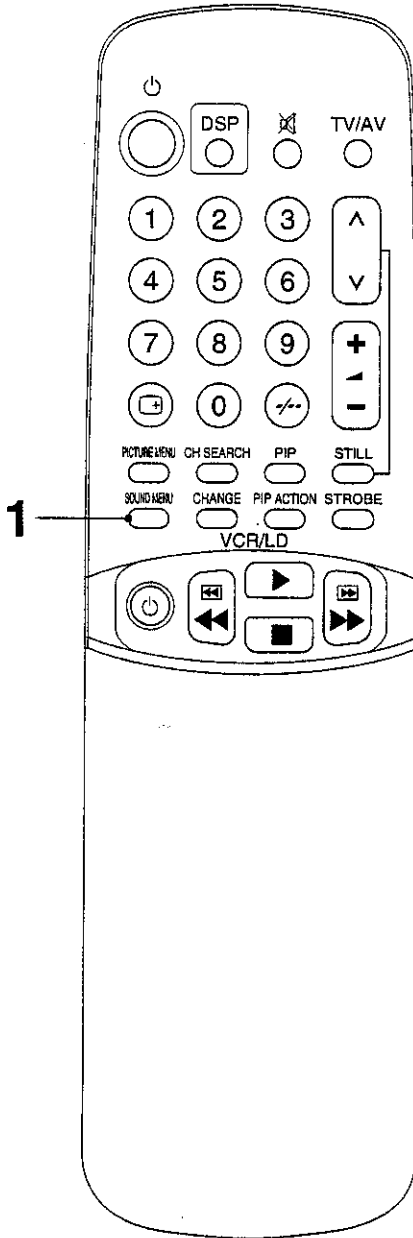

On-Screen	Function
S-AUTO	Sound and Music signals are altered and the best sound is automatically adjusted; sound (e.g. News and Human voice, etc.) is adjusted so as to be easy to hear and music is adjusted to give background impression.
S-STANDARD	For Normal use.
S-4D WOOFER	Amplifies the low frequencies and outputs the optimum sound.

Helpful Hint

- (1) You can change the level of each Function (BASS, TREBLE, BALANCE) for each Sound Menu. Please refer to page 40.
- (2) Sound menu mode will be memorized for each TV, AV1, AV2, AV3 and GAME mode.

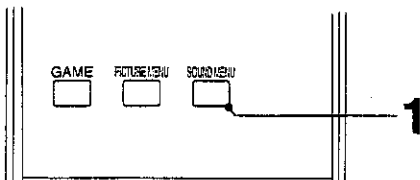

Picture / Sound Menu Operation

Method

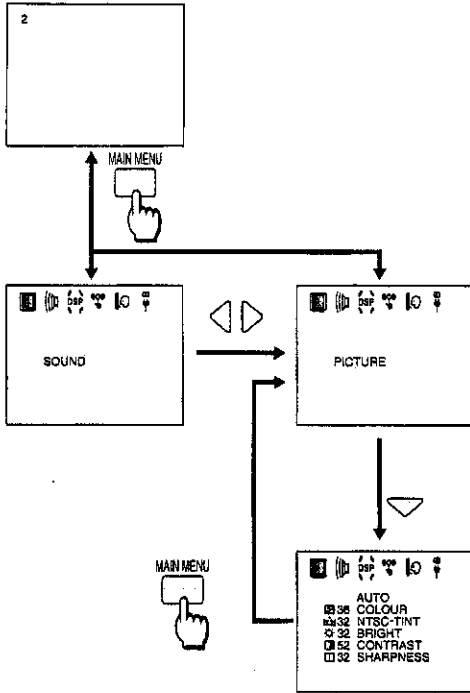

Picture Menu

Push	Item	Effect	Indicator
Select	COLOUR		
Select	NTSC-TINT		
Select	BRIGHT		
Select	CONTRAST		
Select	SHARPNESS		

Note:

- (1) When the set to Picture-in-Picture mode, the main and sub pictures are both adjusted simultaneously.
- (2) Even if the TV is not set to "NTSC" mode, "NTSC-TINT" will be displayed and level adjustment would be possible. But it would not function.
- (3) At the time of TEXT, only the brightness and the contrast can be adjusted.

Method

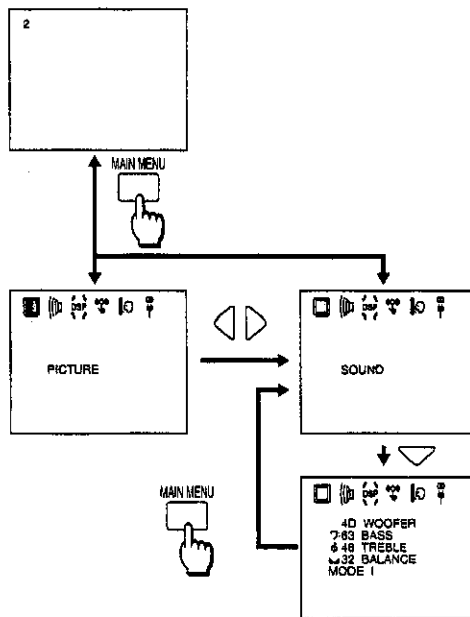

Sound Menu

Push	Item	Effect	Indicator
Select	BASS		
Select	TREBLE		
Select	BALANCE		
Select	STEREO MODE	Select	MODE 1

Note:

- (1) When the set to Picture-in-Picture mode, the main and sub sound are both adjusted simultaneously.
- (2) Stereo mode is not displayed when there is no NICAM, A2 (German) Stereo broadcast.
- (3) When SOUND AUTO mode is selected in Sound Menu Operation, BASS and TREBLE can not be adjusted and they are not displayed.

Helpful Hint (N Normalisation)

By pushing the Normal "N" Button on the Remote Control while the Picture or Sound menu is displayed, the selected menu will be changed to the Normal Mode.

Normalisation will not occur if the menu is not displayed when the "N" Button is pushed.

The Normal mode is the factory preset condition. Returning to this original condition is called "Normalisation".

DSP (Digital Surround Processor) Menu Operation

Method

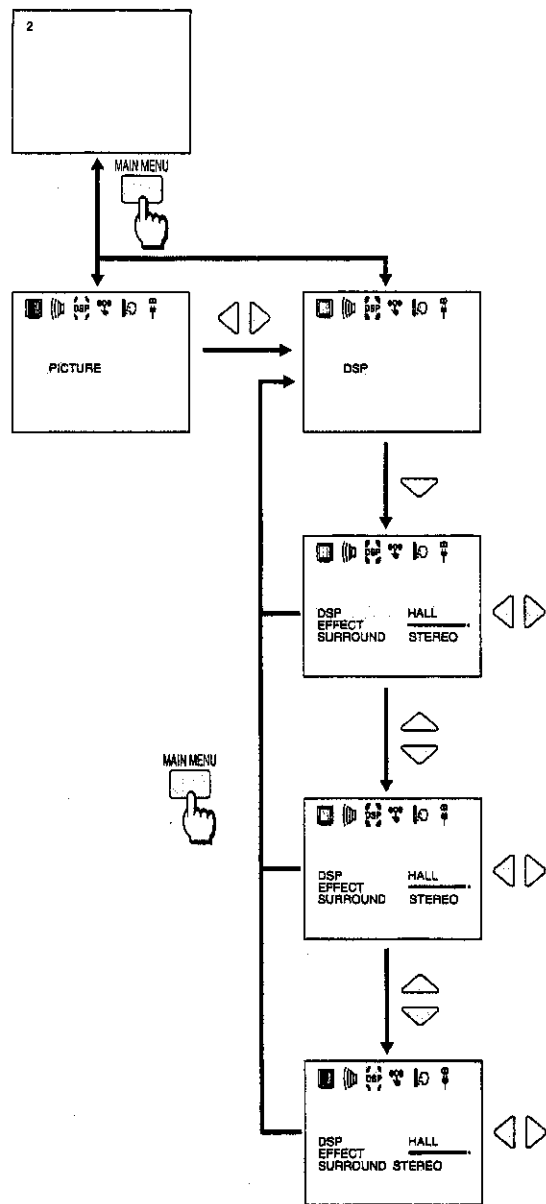

DSP (Digital Surround Processor) Mode

The following four DSP mode can be selected.

STADIUM	Allows you to enjoy the sounds of a sports or concert event held in a stadium.
HALL	Provides the same natural echo effects which you hear in a concert hall or music hall.
CINEMA	In this mode sounds are presented in the same manner as in a cinema, allowing for easier listening to both voice and music.
OFF	DSP Mode is OFF.

EFFECT Mode

The delay time for each DSP mode can be varied in three steps, and the DSP effect can be changed.

SURROUND Mode

The surround setting (STEREO, MONO) for AV mode can be selected.

Note:

EFFECT mode and SURROUND mode are not displayed when the DSP mode is OFF.

Feature Menu Operation

Method

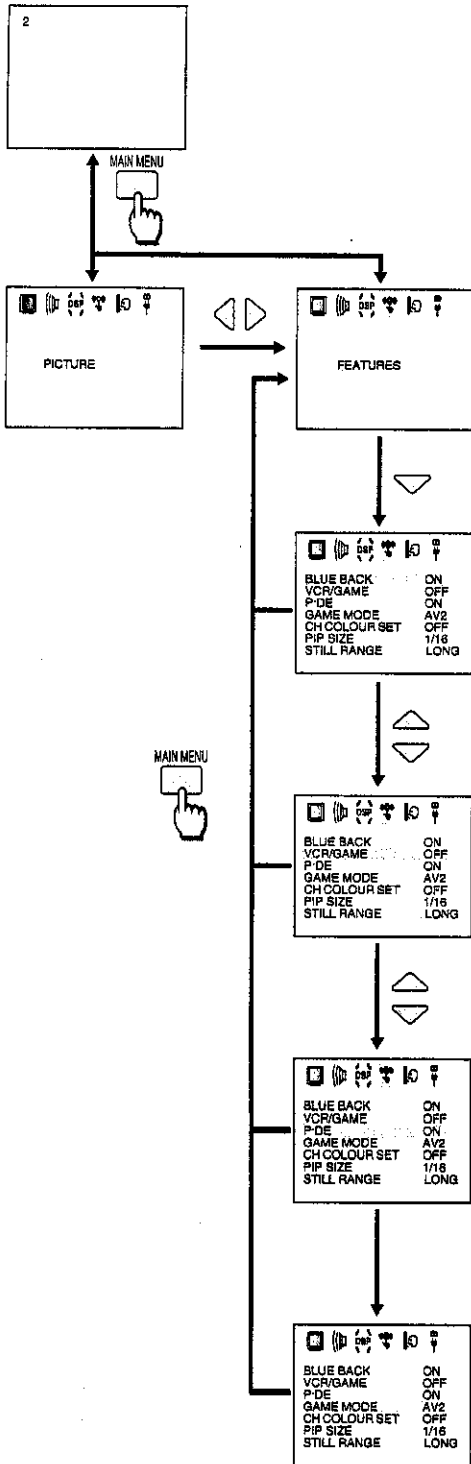

BLUE BACK Mode

When no picture signal is received, or the signal is weak, the screen reverts to a blue background colour and the Sound is muted.

Disable this Feature to continue watching very weak signals.

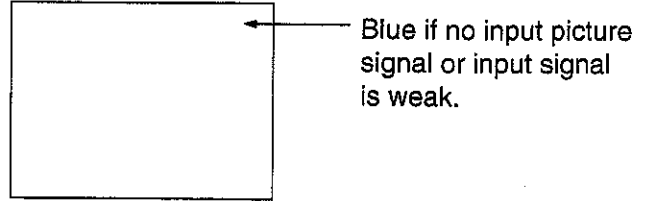

Note:

If BLUE BACK Mode is set on while a VCR signal is being viewed, selecting CUE or REVIEW may cause the screen to revert to the blue background colour. Disable this Feature to view correctly.

VCR/GAME Mode

Reproduction of irregular signals, such as certain TV games and rental video tapes, may be improved.

P•DE Mode (Picture Detail Enhancer)

(No display at the time of TEXT)

The Picture Detail Enhancer System is designed to improve the picture sharpness. It should be OFF position to reduce picture noise during poor quality reception conditions.

P•DE Mode ON condition

When the Picture Detail Enhancer System is ON, the picture will be sharper.

P•DE Mode OFF condition

When the Picture Detail Enhancer System is OFF, picture noise will be softened and less sharp.

GAME Mode

Select the AV mode (AV1~3) which connects the game.

When the game button is pushed, the unit will switch to the AV mode set, and will enter the picture menu and sound menu adjusted for the game mode.

The game mode Indicator will change as follows.

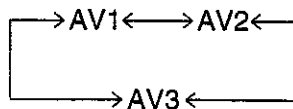

Method

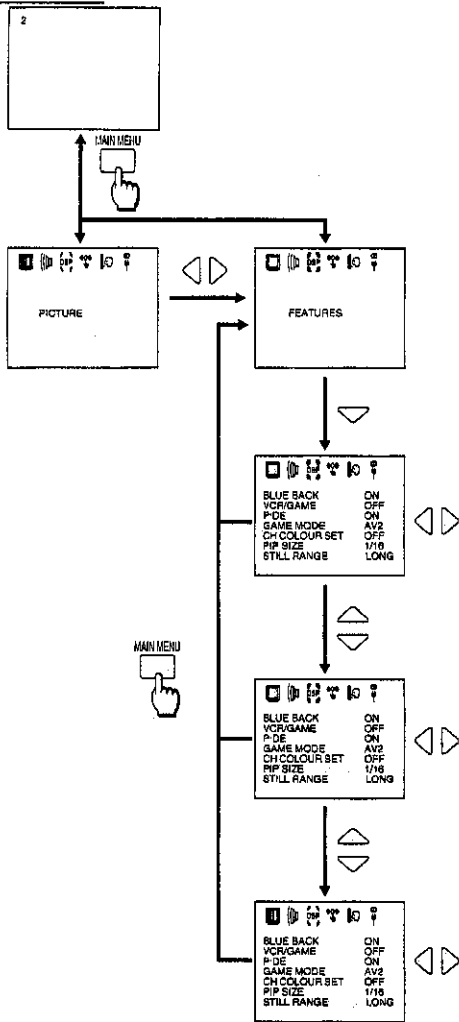

CH (Channel) COLOUR SET Mode

(No display for AV Mode)

Adjustment can be made for each position/channel to lighten the colour of TV broadcast station for which the colour is too deep. Turn on for the position/channel for which the colour is too deep.

PIP (Picture in Picture) SIZE Mode

(No display for TC-29GF80R, TC-29GF82G and TC-29GF82H)

This feature allows the user to change the sub picture size (STROBE/PIP/CH SEARCH).

- 1/16 1/16 of the size of the main picture.
- 1/9 1/9 of the size of the main picture.

STILL RANGE Mode

(No display for TC-29GF80R, TC-29GF82G, TC-29F85R and TC-29GF82H)

This feature allows the user to set the time for recording frame forward and frame back images.

PAL and SECAM System

- LONG Images from about 20 seconds before the present image will be recorded into 8 still frame pictures.
- SHORT Images from about 5 seconds before the present image will be recorded into 8 still frame pictures.

NTSC System

- LONG Images from about 17 seconds before the present image will be recorded into 8 still frame pictures.
- SHORT Images from about 4 seconds before the present image will be recorded into 8 still frame pictures.

Method

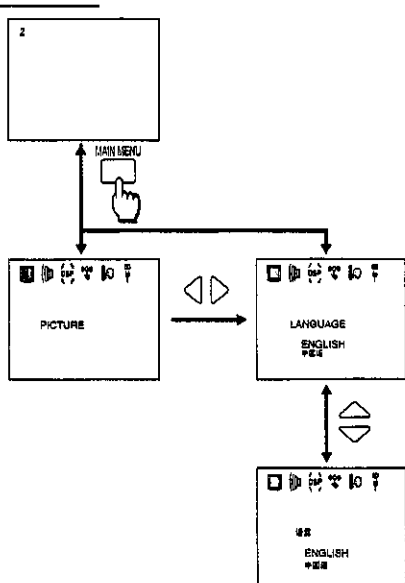

LANGUAGE Menu

Language display on-screen can be selected as left.

Push the "Position Up or Down" Button. The on-screen language display will change.

Picture in Picture Operation (For TX-29GF85T, TC-29GF85G, TC-29GF85R , TX-33GF85T, TX-33GF85X, TC-33GF85G, TC-33GF85H)

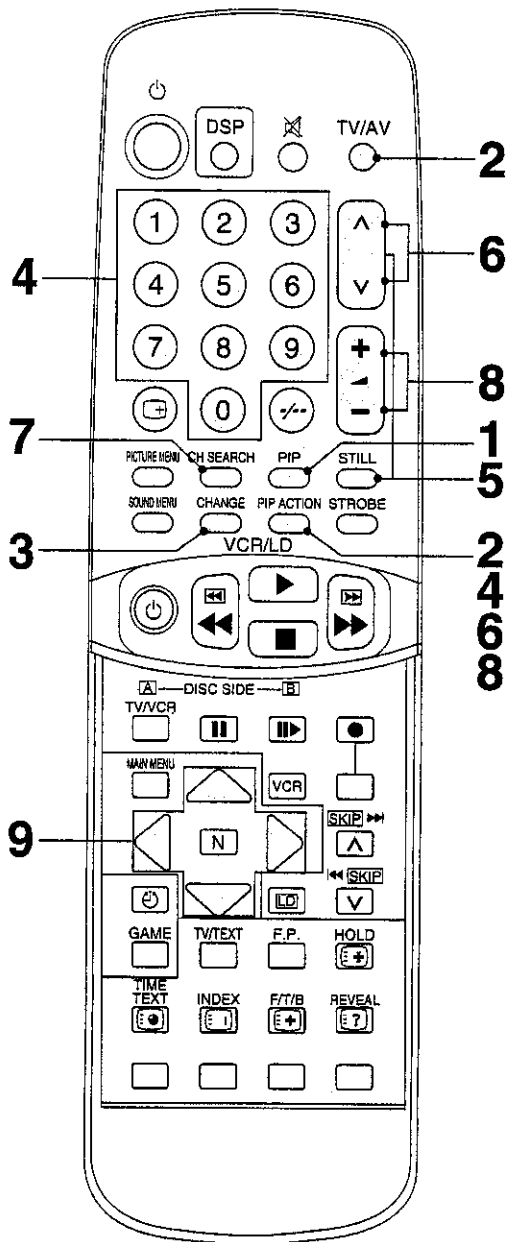

1



Picture in Picture

Push the "PIP" Button to superimpose a sub picture within the main picture.
Push again to cancel the sub picture.

On-Screen indications

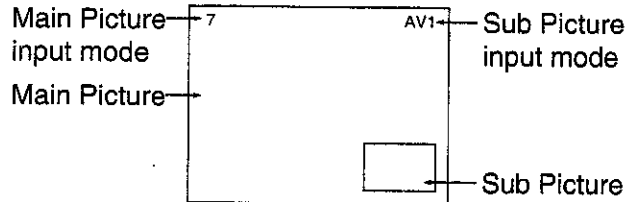

2

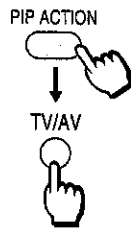

Sub picture TV/AV Mode Selection

Push the "PIP ACTION" button, and TV/AV Button to select TV, AV1, AV2, AV3 input signal mode sequentially.

3



CHANGE

Push the "CHANGE" Button to SWAP from Main picture to sub picture and vice versa.

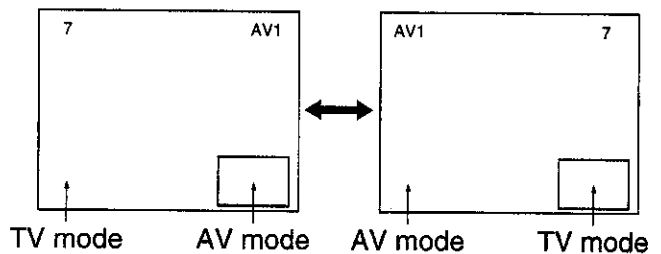

4

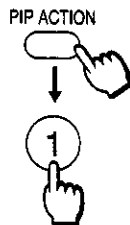

Sub picture Direct Programme (Channel) Number Selection

Push the "PIP ACTION" button and Direct programme Number Selection button to select the programme number.

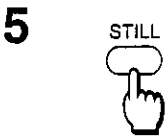

STILL

Picture-in-Picture mode is ON:
Push the Still button to display the sub Picture as a still frame.

Picture-in-Picture mode is OFF:
Push the Still button and the Main Picture mode will change to a still frame Sub Picture.

Push the programme Number Up "▲" button to move the picture one frame forward, or Programme Number Down "▼" button to move the picture one frame back.
(Not equipped for TC-29GF85R)

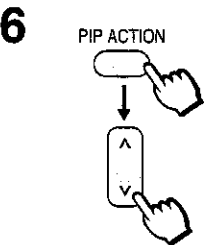

Sub picture Programme Number Selection

Push the "PIP ACTION" button and Programme Number Up "▲" or Down "▼" Button to select the next higher or lower programme number.

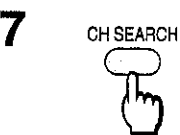

CH (Channel) SEARCH

By pushing this button, it is possible to search through all programmed numbers and display a picture on the sub picture screen.
Push the desired programme number.

For TX-29GF85T, TC-29GF85G, TX-33GF85T, TX-33GF85X, TC-33GF85G, TC-33GF85H

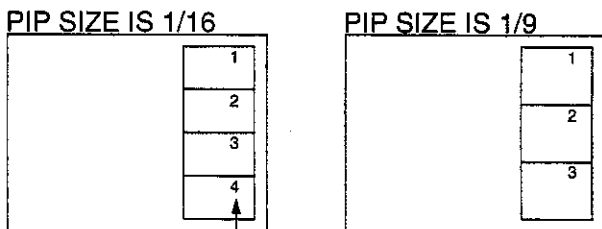

Channel Search Number

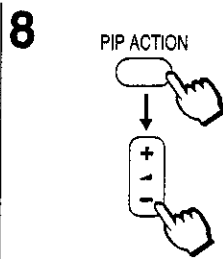
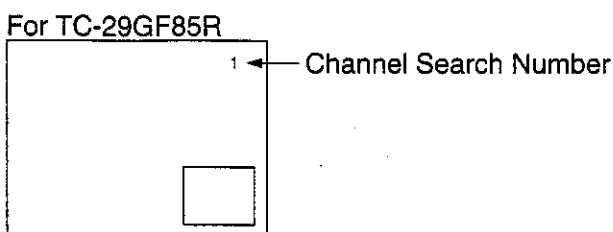

Sub picture Volume adjustment

Push the "PIP ACTION" button, and volume Up "+" or Down "-" Button to increase or decrease the sub picture sound volume level.



Note:

- (1) The volume for the main picture on sub-picture can be adjusted separately.
- (2) When the SUB Picture is selected, only MONO sound is heard.

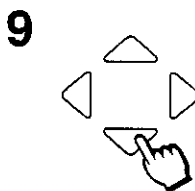

Position Buttons

By pushing each "Position" Button, you can easily select the position of the Sub Picture on the screen.

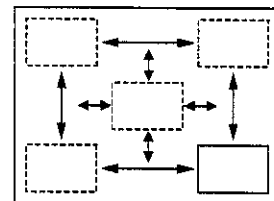

Note:

By pushing the Normal "N" Button while the picture in picture mode is activated, the Sub Picture position will move to the bottom Right corner.

(For TX-29GF85T, TX-33GF85T, TX-33GF85X)

- Teletext features may vary depending on the Broadcasting Companies and is only available if the channel selected is transmitting Teletext.
- When in teletext mode, the volume may still be altered to the desired listening level.

What is LIST mode?

In LIST mode, four differently coloured page numbers are situated at the bottom of the screen. Each of these numbers can be altered and stored in the TV's memory.

What is FASTEXT?

In FASTEXT mode, four differently coloured subjects are situated at the bottom of the display. To access more information about one of these subjects, push the appropriately coloured button. This facility enables fast access to information of the subjects shown.

What are the advantages?

- Page selection at the touch of a Colour-coded Button.
- Easy to use step-by-step selection of the topical subject.
- Reduction of waiting time.
- Page status line at bottom of screen so you always know which Button will take you to the desired information.

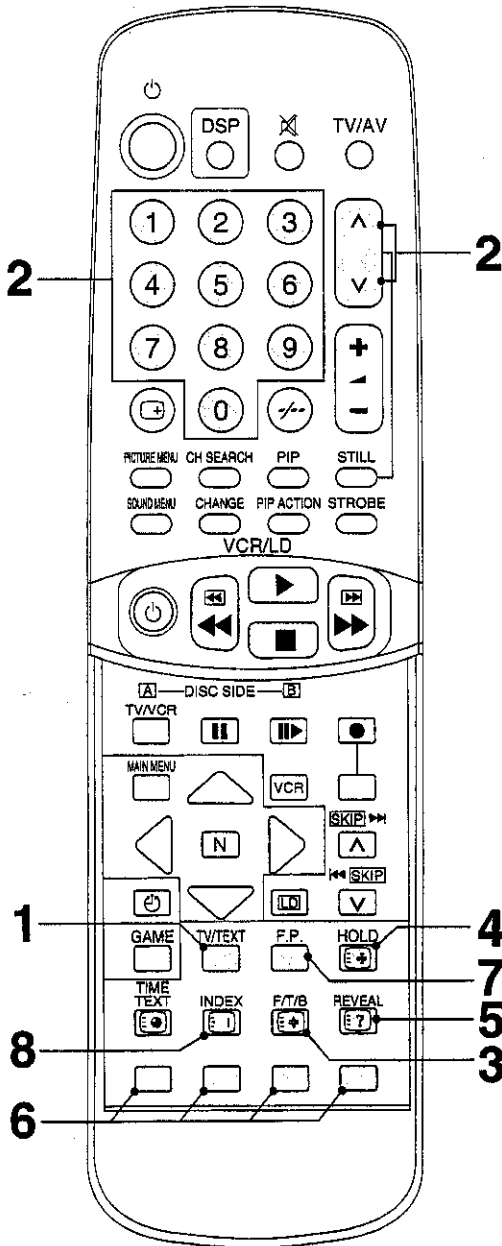

1 **TV/Teletext mode**
 By pushing the "TV/TEXT" Button, to change the TV/Teletext mode as follows.



TV → TEXT

2 **Page Selection**
 Pages can be selected in two ways:
 a) Push the Up/Down Buttons to increase or decrease the page number by one.
 b) By entering the page number, using 0-9 on the remote control.

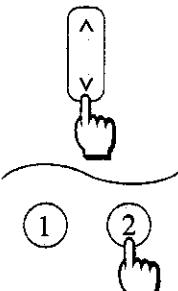

3 **Full/Top/Bottom**
 Push to expand the Top half of the page.
 Push again to expand the Bottom half.
 Push again to return to normal (FULL) size.



4 **Hold**
 Push to hold the current page.
 Push again to cancel the hold.



5 **Reveal**
 Push to reveal hidden words e.g. quiz page answers.
 Push again to hide.



6 **Colour-Coded Buttons**
 In FASTEXT mode these correspond to the differently coloured subjects.
 In LIST mode they correspond to the differently coloured page numbers.

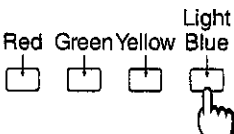

7 **Favourite Page (F. P.)**
 Stores a favourite page in memory for instant recall. To store such a page, the TV must be in LIST mode, and the programme position must be from 1-125 (CH SELECT=DIRECT)/0-99 (CH SELECT=POS.). Push the Light BLUE Button, select the page number, then push List Store. The page number is now stored.
 Push F.P. to recall this page.



8 **Index**
 Push INDEX to return to the main index page.



Sub Coded Page Access

When teletext information exceeds more than one page, it may take some time for the automatic changing of the sub pages to reach the sub page you require. It is possible to enter your required sub page and continue watching the normal programme until the correct sub page is found.

Select the required page number using Buttons 0-9.

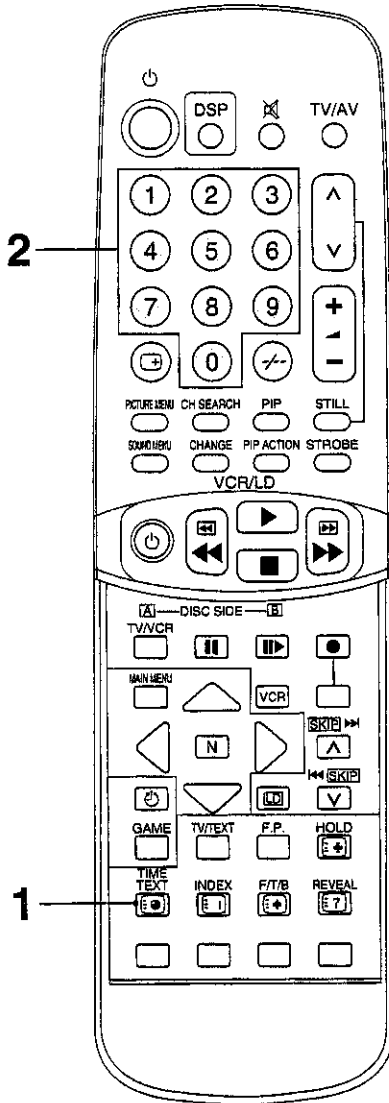

1



Push TIME TEXT "T****" will be displayed (top Left of the screen).

2

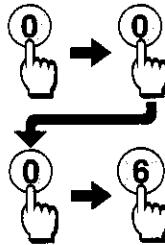

Enter desired sub page number before the "T****" disappears.

To select page 6 enter 0, 0, 0 and 6.

Teletext Menu Operation

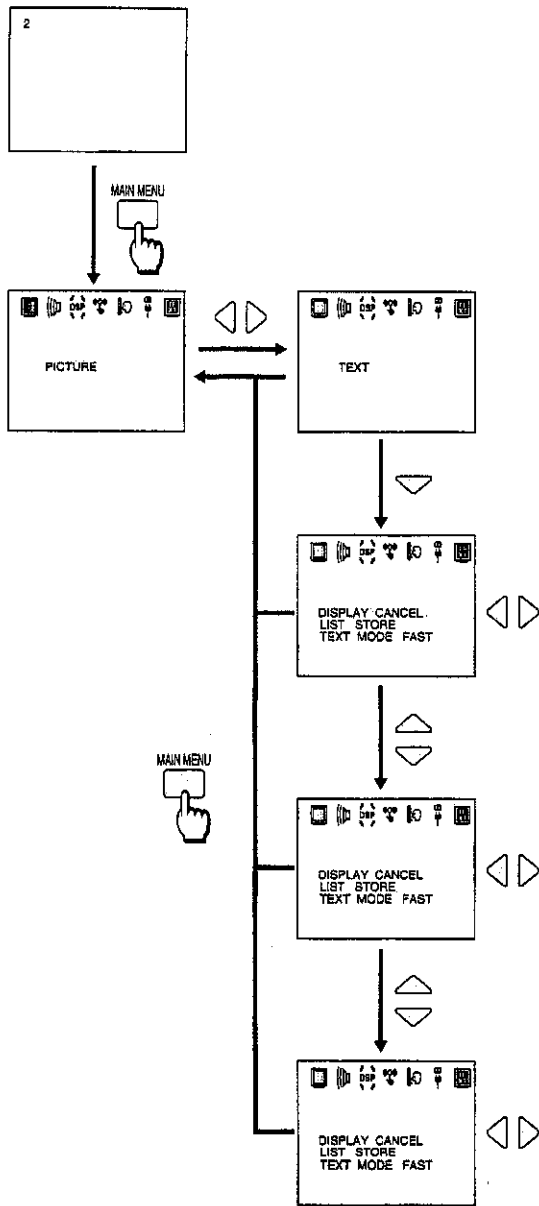

DISPLAY CANCEL

Push the Position Left "<" or Right ">" button to view the TV picture whilst searching for a Teletext page. When found, the screen will display the page number at the top left. Push the TV/TEXT twice to return to normal TV operation.

News Flash

When a news flash page has been selected, push Position Left "<" or Right ">" button to view the TV picture, when an update is received, it will be displayed on screen. Push TV/TEXT twice to return to normal TV operation.

Update

Push Position Left "<" or Right ">" button to see the update of information on certain pages. When an update is received, the page number will be displayed at the top left of the screen. Push TV/TEXT twice to return to normal TV operation.

LIST STORE

In LIST mode the four page numbers can be altered for channel positions 1-125 (CH SELECT=DIRECT)/0-99 (CH SELECT=POS.). To do this, push one of the coloured Buttons and enter the new page number. Push and hold List Store, the page numbers will change colour.

TEXT MODE

Push to change from FASTEXT mode to LIST mode and vice versa. In FASTEXT mode four differently coloured subjects are displayed at the bottom of the page. Push the appropriate coloured Button to access more information about one of these subjects.

Manufacturer setting

Remote Control Operation is possible for the VCR's and LD's of the various manufacturers.

After completion of setting, execute the various operations after pushing the VCR or the LD button.

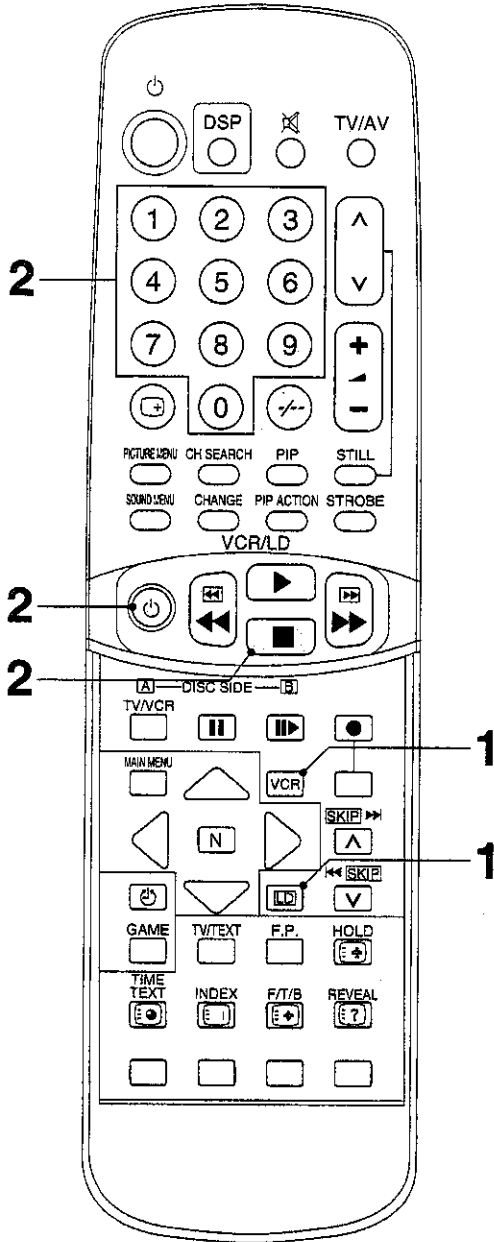

1 Push the button of the unit to be set (VCR or LD).

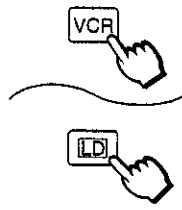

2 While pushing the VCR/LD Power button, push the manufacturer code setting (enter the two digit code), and push the VCR/LD Stop button.

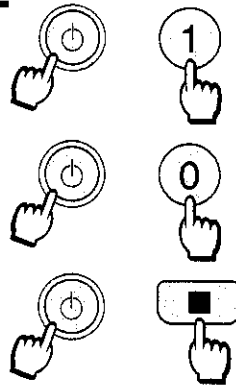

VCR

Manufacturer	Code	Manufacturer	Code
Panasonic/ National	10, 11, 12, 13	NEC	40, 41, 42, 43
AIWA	15, 16	ORION	45, 46
FUJITSU	20	PHILIPS	50
HITACHI	25, 26, 27	SANYO	55, 56, 57, 58
JVC	30, 31, 32	SHARP	60, 61,
MITSUBISHI	35, 36	SONY	65, 66, 67
		TOSHIBA	70, 71

LD

Manufacturer	Code	Manufacturer	Code
Panasonic	10, 11, 12, 13	SUMSUNG	30
KENWOOD	15, 16	SHARP	35
PHILIPS	20	SONY	40, 41, 42, 43
PIONEER	25		

Note:

After setting, execute operation confirmation.
If there is no operation, set a different code.

Helpful Hint

- (1) The respective VCR/LD manufacturer code is cancelled when the battery has been exchanged. please set it again.
- (2) Depending on the model, operation of VCR's or LD's of the manufacturers listed above may not be possible.
- (3) In some cases, new products may not be operative.
- (4) It will not operate with other than the above manufacturers.



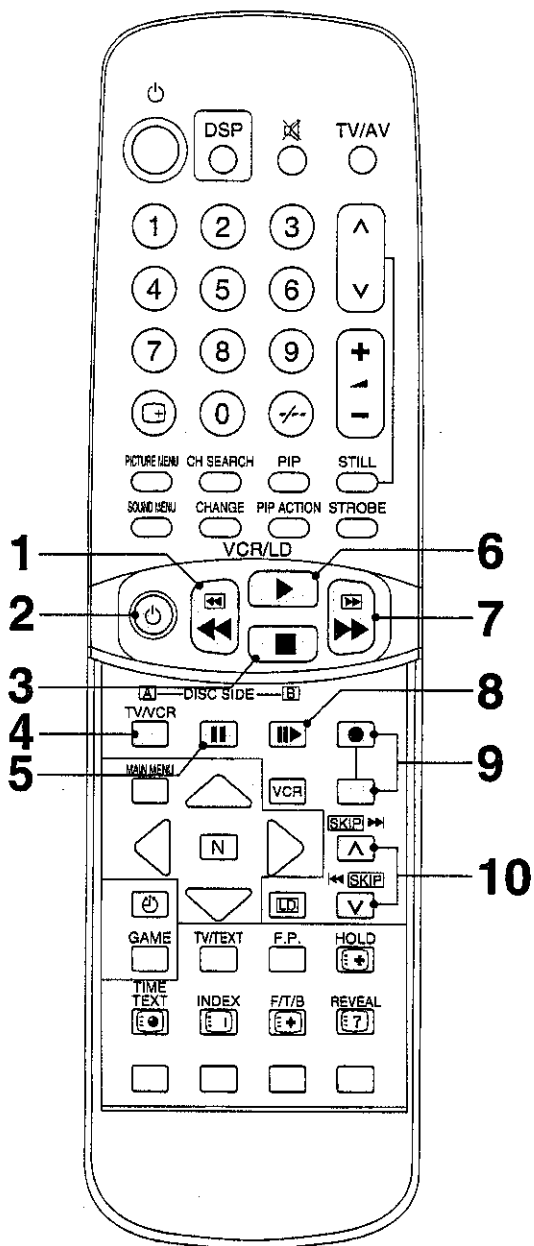







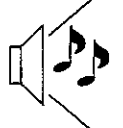
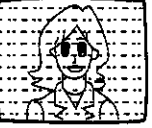

Execute the various operations after pushing the VCR or LD button.

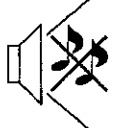

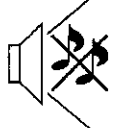
Button	Function	
	VCR	LD
1	Rew (Rewind)/ Review Button	Rew (Rewind)/ Review Button
2	VCR Power Button	LD Power Button
3	Stop Button	Stop Button
4	TV/VCR Selection Button	DISC SIDE A Selection Button
5	Pause/Still Button	Pause/Still Button
6	Play Button	Play Button
7	FF (Fast Forward)/ Cue Button	FF (Fast Forward)/ Cue Button
8	Still Advance Button	DISC SIDE B Selection Button
9	Rec (Record) Button	Not Workable
10	Programme Number Up and Down Buttons for VCR	Programme Skip Button

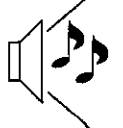
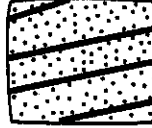
Troubleshooting

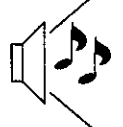
Before you call for service, determine the symptoms and make a few simple checks as shown below.

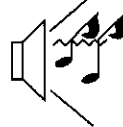
Symptoms		Checks
Picture	Sound	
 Snowy Picture	 Noisy Sound	Aerial Location, direction or Connections
 Multiple Image	 Normal Sound	Aerial Location, direction or Connections
 Interference	 Noisy Sound	Electrical Appliances Cars/Motorcycles Fluorescent Lamps
 Normal Picture	 No Sound	Volume (Check whether the mute function has been activated on the Remote Control.)
 No Picture	 No Sound	Not plugged into AC outlet Not switched on Contrast and Brightness/Volume setting (Check by pushing the Power Switch or Stand-by Button on the Remote Control.)
 No Colour	 Normal Sound	Colour Control
 Scrambled	 Normal or Weak Sound	Retune Channels
 Coloured Patches	 Normal Sound	Magnetic interference from unshielded equipment TV set moved while "ON" Turn the TV set off for 30 mins, using the "Power" Switch on the TV set.
 No Colour	 Noisy Sound	Sound System (Refer to page 34) Colour System (Refer to page 35)

Power Source

AC 110-240 V, 50/60 Hz

Power Consumption

TX-29GF85T, TC-29GF85R 185 W Stand-by condition 4 W	TC-29GF80R 160 W Stand-by condition 4 W	TC-29GF82G, TC-29GF82H 165 W Stand-by condition 4 W
TC-29GF85G 190 W Stand-by condition 4 W	TX-33GF85T 200 W Stand-by condition 4 W	TX-33GF85X, TC-33GF85G, TC-33GF85H 205 W Stand-by condition 4 W

Receiving System

21 Systems		Function
1	PAL B, G, H	Reception of broadcast transmissions and Playback from Video Cassette Tape Recorders
2	PAL I	
3	PAL D, K	
4	SECAM B, G	
5	SECAM D, K	
6	SECAM K1	
7	NTSC M (NTSC 3.58/4.5 MHz)	
8	NTSC 4.43/5.5 MHz	Playback from Special VCR's
9	NTSC 4.43/6.0 MHz	
10	NTSC 4.43/6.5 MHz	
11	NTSC 3.58/5.5 MHz	
12	NTSC 3.58/6.0 MHz	
13	NTSC 3.58/6.5 MHz	
14	SECAM I	
15	PAL 60 Hz/5.5 MHz	Playback from Special Disc Players and Special VCR's
16	PAL 60 Hz/6.0 MHz	
17	PAL 60 Hz/6.5 MHz	
18	SECAM 60 Hz/5.5 MHz	
19	SECAM 60 Hz/6.0 MHz	
20	SECAM 60 Hz/6.5 MHz	
21	NTSC 50 Hz/4.5 MHz	

Receiving Channels

Regular TV

VHF BAND

2-12	(PAL/SECAM B, K1)
0-12	(PAL B AUST.)
1-9	(PAL B N.Z)
1-12	(PAL/SECAM D)
1-12	(NTSC M Japan)
2-13	(NTSC M U.S.A)

UHF BAND

21-69	(PAL G, H, I/SECAM G, K, K1)
28-69	(PAL B AUST.)
13-57	(PAL D, K)
13-62	(NTSC M Japan)
14-69	(NTSC M U.S.A)

CATV

S1-S20	(OSCAR)
1-125	(U.S.A. CATV)
C13-C49	(JAPAN)
S21-S41	(HYPER)
Z1-Z37	(CHINA)
5A, 9A	(AUST.)

Tuning System

Frequency synthesizer
Auto Search Tuning
POS (Position) : 100 Position
DIRECT : 125 Position

Picture Tube

	Type29	Type33
Overall Picture tube measured diagonally	72 cm	84 cm
Viewable Picture tube measured diagonally	68 cm	78 cm
CRT Deflection	108°	108°

Audio Output

37 W [10 W + 10 W + 13 W (Woofer Speaker) + 4 W (Centre Speaker)]

Headphones

3.5 mm Plug

Aerial Impedance

75 Ω Unbalanced coaxial

Video/Audio Terminals

AV 1, 2, 3	S-Video In	Y: 1.0 Vp-p, 75 Ω C: 0.3 Vp-p, 75 Ω
	Video In	1 Vp-p, 75 Ω
	Audio In	Approx. 400 mV 47 K Ω
Monitor Out	Video Out	1 Vp-p, 75 Ω
	Audio Out	Approx. 400 mV 1 K Ω
Surround Terminals Impedance	8~16 Ω	
Woofer Impedance	6 Ω	

Accessories Supplied

Woofer Speaker		
Remote control Transmitter	EUR511020	TX-29GF85T, TX-33GF85T, TX-33GF85X
	EUR511021	TC-29GF85G, TC-33GF85G, TC-33GF85H
	EUR511022	TC-29GF85R
	EUR511023	TC-29GF80R, TC-29GF82G, TC-29GF82H
R6 (AA) Battery \times 2		

Optional Accessories

	Type29	Type33
Set Stand	TY-S28WG30G	TY-S32WG35G

Dimensions (W \times D \times H)

Type29	Type33
698 mm \times 493 mm \times 602 mm	800 mm \times 540 mm \times 687 mm

Weight (Mass)

Type29	Type33
44.0 kg (Net)	59.0 kg (Net)

Note:

Design and Specifications are subject to change without notice. Weight and Dimensions shown are approximate.

Customer's Record

The model number and serial number of this product can be found on its rear cover. You should note this serial number in the space provided below and retain this book plus your purchase receipt as a permanent record of your purchase to aid in identification in the event of theft or loss, and for Warranty Service purposes.

Model Number _____

Serial Number _____

Matsushita Electric Industrial Co., Ltd.

Central P.O. Box 288, Osaka 530-91, Japan

Printed in Japan
S0996