

PANASONIC CONSUMER ELECTRONICS COMPANY,  
DIVISION OF  
MATSUSHITA ELECTRIC CORPORATION OF AMERICA  
One Panasonic Way  
Secaucus, New Jersey 07094

PANASONIC SALES COMPANY,  
DIVISION OF  
MATSUSHITA ELECTRIC OF PUERTO RICO,  
INC., Ave. 65 de Infanteria, Km. 9.5  
San Gabriel Industrial Park  
Carolina, Puerto Rico 00985

## Panasonic Color Television Limited Warranty

### Limited Warranty Coverage

If your product does not work properly because of a defect in materials or workmanship, Panasonic Consumer Electronics Company or Panasonic Sales Company (collectively referred to as "the warrantor") will, for the length of the period indicated on the chart below, which starts with the date of original purchase ("warranty period"), at its option either (a) repair your product with new or refurbished parts, or (b) replace it with a new or a refurbished product. The decision to repair or replace will be made by the warrantor.

TV CATEGORIES	ALL PARTS EXCEPT CRT	LABOR	CRT	SERVICE
9"-21" diagonal	1 (ONE) YEAR	90 DAYS	2 (TWO) YEARS	CARRY-IN

During the "Labor" warranty period there will be no charge for labor. During the "Parts" warranty period, there will be no charge for parts. You must carry-in your product or arrange for in-home service (in-home service available only for 22" [diagonal] and larger screen), as applicable, during the warranty period. If non-rechargeable batteries are included, they are not warranted. This warranty only applies to products purchased and serviced in the United States or Puerto Rico. This warranty is extended only to the original purchaser of a new product which was not sold "as is". A purchase receipt or other proof of the original purchase date is required for warranty service.

### Carry-in or In-Home Service

For Carry-In or In-Home Service (as applicable) in the United States call 1-800-211-PANA(7262) or visit Panasonic Web Site: <http://www.panasonic.com>  
For assistance in Puerto Rico call Panasonic Sales Company (787)-750-4300 or fax (787)-768-2910.

In-Home service, if applicable, requires clear, complete and easy access to the product by the authorized servicer and does not include removal or re-installation of an installed product. It is possible that certain in-home repairs will not be completed in-home, but will require that the product, or parts of the product, be removed for shop diagnosis and/or repair and then returned.

### Limited Warranty Limits And Exclusions

This warranty ONLY COVERS failures due to defects in materials or workmanship, and DOES NOT COVER normal wear and tear or cosmetic damage, nor does it cover markings or retained images on the picture tube resulting from viewing fixed images (including, among other things, letterbox pictures on standard 4:3 screen TV's, or non-expanded standard 4:3 pictures on wide screen TV's, or onscreen data in a stationary and fixed location). The warranty ALSO DOES NOT COVER damages which occurred in shipment, or failures which are caused by products not supplied by the warrantor, or failures which result from accidents, misuse, abuse, neglect, mishandling, misapplication, alteration, faulty installation, set-up adjustments, misadjustment of consumer controls, improper maintenance, power line surge, lightning damage, modification, or commercial use (such as in a hotel, office, restaurant, or other business), rental use of the product, service by anyone other than a Factory Servicenter or other Authorized Servicer, or damage that is attributable to acts of God.

**THERE ARE NO EXPRESS WARRANTIES EXCEPT AS LISTED UNDER "LIMITED WARRANTY COVERAGE". THE WARRANTOR IS NOT LIABLE FOR INCIDENTAL OR CONSEQUENTIAL DAMAGES RESULTING FROM THE USE OF THIS PRODUCT, OR ARISING OUT OF ANY BREACH OF THIS WARRANTY.** (As examples, this excludes damages for lost time, cost of having someone remove or re-install an installed unit if applicable, or travel to and from the servicer. The items listed are not exclusive, but are for illustration only.) **ALL EXPRESS AND IMPLIED WARRANTIES, INCLUDING THE WARRANTY OF MERCHANTABILITY, ARE LIMITED TO THE PERIOD OF THE LIMITED WARRANTY.**

Some states do not allow the exclusion or limitation of incidental or consequential damages, or limitations on how long an implied warranty lasts, so the exclusions may not apply to you.

This warranty gives you specific legal rights and you may also have others rights which vary from state to state. If a problem with this product develops during or after the warranty period, you may contact your dealer or Servicenter. If the problem is not handled to your satisfaction, then write to the warrantor's Consumer Affairs Department at the addresses listed for the warrantor.

**PARTS AND SERVICE (INCLUDING COST OF AN IN-HOME SERVICE CALL, WHERE APPLICABLE) WHICH ARE NOT COVERED BY THIS LIMITED WARRANTY ARE YOUR RESPONSIBILITY.**



J3M11001B U  
03/07

\*J3M11001B\*

Printed in Thailand

## ANTENNA/CATV CONNECTIONS

### ANTENNA CONNECTIONS

Connect the antenna to the antenna jack.

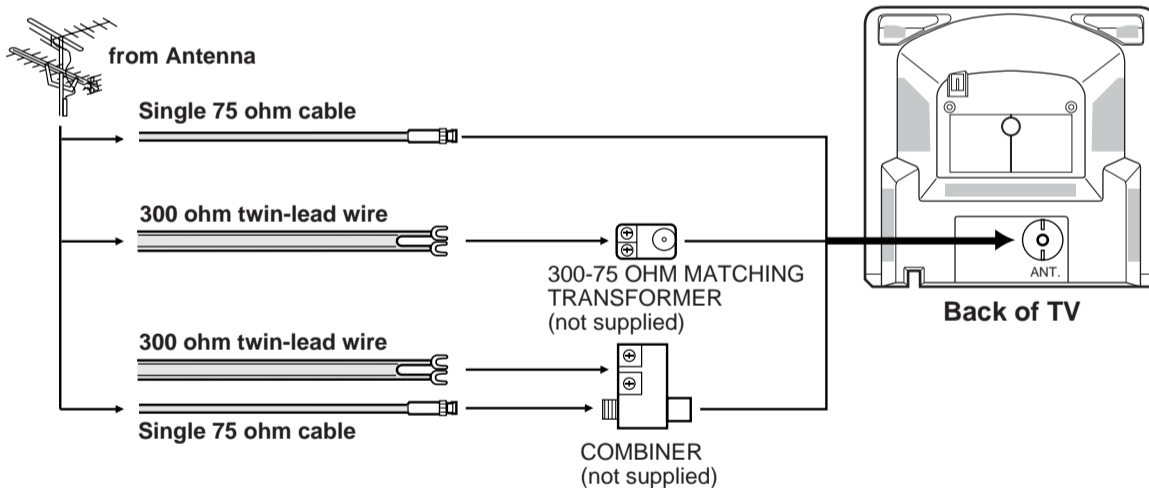

### CATV CONNECTIONS

Incoming CATV

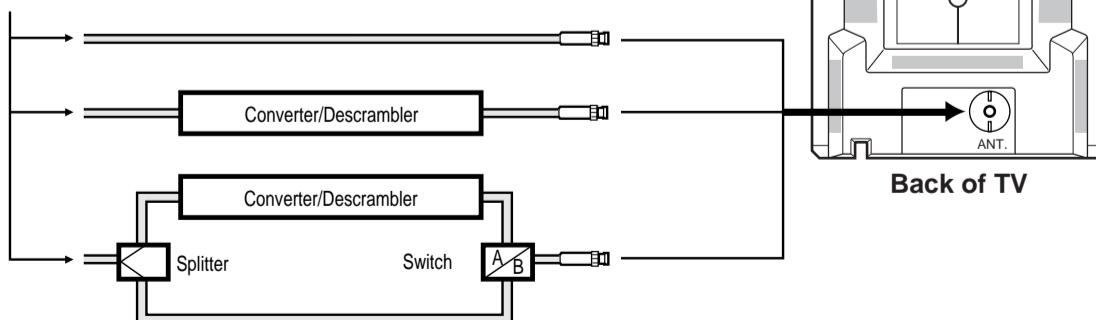

#### For Subscribers to Basic Cable TV Service

For basic cable service not requiring a converter/descrambler box, connect the CATV 75 ohm coaxial cable directly to the antenna jack on the back of the television.

#### For Subscribers to Scrambled Cable TV Service

If you subscribe to a cable service which requires the use of a converter/descrambler box, connect the incoming cable to the converter/descrambler box and connect the output of the box to the antenna jack on the back of the television. Follow the connections shown left. Set the television to the output of the converter/descrambler box (usually channel 3 or 4) and use the converter/descrambler box to select channels.

ENGLISH

## OWNER'S MANUAL

Panasonic®

## COLOR TELEVISION

CT-13R18B  
CT-13R28W  
CT-13R38S

### CAUTION

Changes or modifications not expressly approved by the party responsible for compliance with the FCC Rules could void the user's authority to operate this equipment.

### ATTENTION

If you purchase a universal remote control from your local retailer, please contact the remote manufacturer for the required programming code.

### TV/CATV MODE SELECTION

When shipped from the factory, the TV/CATV menu option is set to the "CATV" (Cable Television) mode. If not using CATV, set this menu option to "TV" mode.

**For Product Information, Operating Assistance, Literature Request, Dealer Locations, and all Customer Service inquiries please contact:**  
**1-800-211-PANA (7262), Monday-Friday 9am - 9pm; Saturday-Sunday 10am - 7pm, EST.**

Web Site: <http://www.panasonic.com>

You can purchase parts, accessories or locate your nearest servicenter by visiting our Web Site.

### Accessory Purchases:

1-800-332-5368 (Customer Orders Only)

Panasonic Services Company 20421 84th Avenue South, Kent, WA 98032

(6 am to 5 pm Monday - Friday; 6 am to 10:30 am Saturday; PST)

(Visa, MasterCard, Discover Card, American Express, Check)

### Service in Puerto Rico

Matsushita Electric of Puerto Rico, Inc. Panasonic Sales Company/Factory Servicenter:

Ave. 65 de Infanteria, Km. 9.5, San Gabriel Industrial Park, Carolina, Puerto Rico 00985

Phone (787) 750-4300

Fax (787) 768-2910

This television has an extended tuning range and can tune most cable channels without using a cable company supplied converter box. Some cable companies offer "premium pay channels" in which the signal is scrambled. Descrambling these signals for normal viewing requires the use of a descrambler device which is generally provided by the cable company.

#### For Subscribers to Unscrambled Basic Cable with Scrambled Premium Channels

If you subscribe to a cable service in which basic cable channels are unscrambled and premium channels require the use of a converter/descrambler box, you may wish to use a two-set signal splitter (sometimes called a "two-set coupler") and an A/B switch box from the cable installer or an electronics supply store. Follow the connections shown left. With the switch in the "B" position, you can directly tune any unscrambled channels on your TV. With the switch in the "A" position, tune your TV to the output of the converter/descrambler box (usually channel 3 or 4) and use the box to tune scrambled channels.

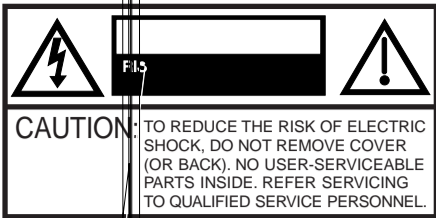

**WARNING:** TO PREVENT FIRE OR SHOCK HAZARD, DO NOT EXPOSE THIS APPLIANCE TO RAIN OR MOISTURE.

## IMPORTANT SAFEGUARDS

- 1. READ INSTRUCTIONS-** All the safety and operating instructions should be read before the unit is operated.
- 2. RETAIN INSTRUCTIONS-** The safety and operating instructions should be retained for future reference.
- 3. HEED WARNINGS-** All warnings on the unit and in the operating instructions should be adhered to.
- 4. FOLLOW INSTRUCTIONS-** All operating and use instructions should be followed.
- 5. CLEANING-** Unplug this unit from the wall outlet before cleaning. Do not use liquid cleaners or aerosol cleaners. Use a damp cloth for cleaning the exterior cabinet only.
- 6. ATTACHMENTS-** The manufacturer of this unit does not make any recommendations for attachments, as they may cause hazards.
- 7. WATER AND MOISTURE-** Do not use this unit near water. For example, near a bathtub, washbowl, kitchen sink, laundry tub, in a wet basement, or near a swimming pool.
- 8. ACCESSORIES-** Do not place this unit on an unstable cart, stand, tripod, bracket, or table. The unit may fall, causing serious injury, and serious damage to the unit.

- 8A.** An appliance and cart combination should be moved with care. Quick stops, excessive force, and uneven surfaces may cause the appliance and cart combination to overturn.
- 9. VENTILATION-** Slots and openings in the cabinet back or bottom are provided for ventilation, to ensure reliable operation of the unit and to protect it from overheating. These openings must not be blocked or covered. The openings should never be blocked by placing the unit on a bed, sofa, rug, or other similar surface. This unit should never be placed near or over a radiator or heat source. This unit should not be placed in a built-in installation, such as a bookcase, or rack unless proper ventilation is provided or the manufacturer's instructions have been adhered to.
- 10. POWER SOURCE-** This unit should be operated only from the type of power source indicated on the rating plate. If you are not sure of the type of power supply to your home, consult your appliance dealer or local power company. For units intended to operate from battery power, or other sources, refer to the operating instructions.
- 11. GROUNDING OR POLARIZATION-** This unit is equipped with a polarized alternating current line plug (a plug having one blade wider than the other). This plug will fit into the power outlet only one way. This is a safety feature. If you are unable to insert the plug fully into the outlet, try reversing the plug. If the plug still fails to fit, contact your electrician to replace your obsolete outlet. Do not defeat the safety purpose of the polarized plug. If your unit is equipped with a 3-wire grounding-type plug, a plug having a third (grounding) pin, this plug will only fit into a grounding-type power outlet. This too, is a safety feature. If you are unable to insert the plug into the outlet, contact your electrician to replace your obsolete outlet. Do not defeat the safety purpose of the grounding-type plug.

- 12. POWER-CORD PROTECTION-** Power-supply cords should be routed so that they are not likely to be walked on or pinched by items placed upon or against them, paying particular attention to cords at plugs, convenience receptacles, and the point where they exit from the appliance.
- 13. LIGHTNING-** To protect your unit during a lightning storm, or when it is left unattended and unused for long periods of time, unplug it from the wall outlet and disconnect the antenna or cable system. This will prevent damage to the unit due to lightning and power line surges.
- 14. POWER LINES-** An outside antenna system should not be located in the vicinity of overhead power lines, or other electric light or power circuits, or where it can fall into such power lines or circuits. When installing an outside antenna system, extreme care should be taken to keep from touching such power lines or circuits as contact with them might be fatal.
- 15. OVERLOADING-** Do not overload wall outlets and extension cords as this can result in a risk of fire or electric shock.
- 16. OBJECT AND LIQUID ENTRY-** Do not push objects through any openings in this unit as they may touch dangerous voltage points or short out parts that could result in fire or electric shock. Never spill or spray any type of liquid into the unit.
- 17. OUTDOOR ANTENNA GROUNDING-** If an outside antenna or cable system is connected to the unit, be sure the antenna or cable system is grounded to provide some protection against voltage surges and built-up static charges. Section 810 of the National Electrical Code, ANSI/NFPA 70, provides information with respect to proper grounding of the mast and supporting structure, grounding of the lead-in wire to an antenna discharge unit, size of grounding conductors, location of antenna discharge unit, connection to grounding electrodes, and requirements for the grounding electrode.
- 18. SERVICING-** Do not attempt to service this unit yourself as opening or removing covers may expose you to dangerous voltage or other hazards. Refer all servicing to qualified service personnel.
- 19. DAMAGE REQUIRING SERVICE-** Unplug this unit from the wall outlet and refer servicing to qualified service personnel under the following conditions:
  - When the power-supply cord or plug is damaged.
  - If liquid has been spilled, or objects have fallen into the unit.
  - If the unit has been exposed to rain or water.
- If the unit does not operate normally by following the operating instructions. Adjust only those controls that are covered by the operating instructions, as an improper adjustment of other controls may result in damage and will often require extensive work by a qualified technician to restore the unit to its normal operation.
- If the unit has been dropped or the cabinet has been damaged.
- When the unit exhibits a distinct change in performance, this indicates a need for service.

- 20. REPLACEMENT PARTS-** When replacement parts are required, be sure the service technician uses replacement parts specified by the manufacturer or those that have the same characteristics as the original part. Unauthorized substitutions may result in fire, electric shock or other hazards.
- 21. SAFETY CHECK-** Upon completion of any service or repairs to this unit, ask the service technician to perform safety checks to determine that the unit is in proper operating condition.
- 22. HEAT-** The product should be situated away from heat sources such as radiators, heat registers, stoves, or other products (including amplifiers) that produce heat.
- 23. NOTE TO CATV SYSTEM INSTALLER**  
This reminder is provided to call the CATV system installer's attention to Article 820-40 of the NEC that provides guidelines for proper grounding and, in particular, specifies that the cable ground shall be connected to the grounding system of the building, as close to the point of cable entry as practical.

PORTABLE CART WARNING  
(symbol provided by RETAC)



S3125A

EXAMPLE OF ANTENNA GROUNDING AS PER NATIONAL ELECTRICAL CODE

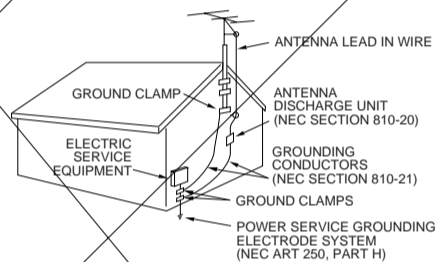

NEC-NATIONAL ELECTRICAL CODE  
§2898A

## REMOTE CONTROL

Before using the remote control transmitter, batteries must first be installed.

### HOW TO INSTALL BATTERIES

1. Slide the battery compartment cover.

Use two "AA" size penlight batteries (supplied) for the transmitter. The batteries may last approximately one year depending on how much the remote control is used. For best performance, it is recommended that batteries should be replaced on a yearly basis, or when the remote operation becomes erratic. Do not mix old and new batteries or different types.

### BATTERY PRECAUTIONS

These precautions should be followed when using batteries in this device:

1. Use only the size and type of batteries specified.
2. Be sure to follow the correct polarity when installing the batteries as indicated in the battery compartment. Reversed batteries may cause damage to the device.
3. Do not mix different types of batteries together (e.g. Alkaline and Carbon-zinc) or old batteries with fresh ones.
4. If the device is not to be used for a long period of time, remove the batteries to prevent damage or injury from possible battery leakage.
5. Do not try to recharge batteries not intended to be recharged; they can overheat and rupture. (Follow battery manufacturer's directions.)

2. Install two "AA" (penlight size) batteries.

3. Replace the battery compartment cover.

## POWER SOURCE

### TO USE AC POWER SOURCE

Use the AC polarized line cord provided for operation on AC. Insert the AC cord plug into a standard 120V 60Hz polarized AC outlet.

### NOTES:

1. Never connect the AC line cord plug to other than the specified voltage (120V 60Hz). Use the attached power cord only.
2. If the polarized AC cord does not fit into a non-polarized AC outlet, do not attempt to file or cut the blade. It is the user's responsibility to have an electrician replace the obsolete outlet.
3. If you cause a static discharge when touching the unit, and the unit fails to function, simply unplug the unit from the AC outlet, wait a few minutes, and plug it back in. The unit should return to normal operation.

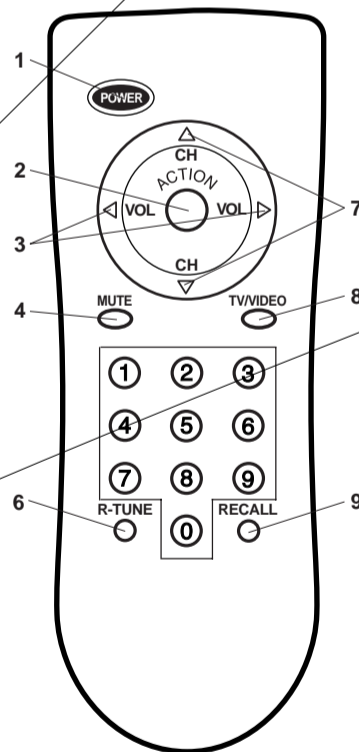

## LOCATION OF CONTROLS

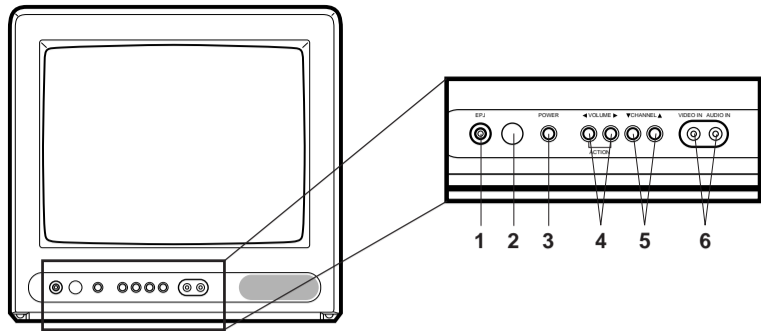

- 1. EPJ (Earphone) Jack** - Plug an earphone or monaural headphones with an 1/8 miniplug into this jack for private listening.
- 2. Remote Sensor** - Signals from the Remote Control unit are received here.
- 3. POWER** - Press to turn the TV on or off.
- 4. VOLUME** ◀/▶ - Press to raise or lower the level of the sound. And also, press to select the desired setting during On-Screen operations.  
**ACTION** - Press to display the On-screen menu function. And also, press to enter or select information for On-Screen operations.
- 5. CHANNEL** ▲/▼ - Press to select a higher or lower numbered channel set into memory. And also, press to select the desired setting during On-Screen operations.
- 6. AUDIO/VIDEO IN Jacks** - Audio and video signal cables from an external source can be connected here.

### NOTE:

If needed customer can enter the OSD by pressing VOLUME ◀ and ▶ of the front panel at the same time.

## SETTING LANGUAGE

This TV can display the channel number, on screen displays and picture adjustments on the screen in English, Spanish or French.

- 1 Press **ACTION**.
- 2 Press ◀ to select the SET UP mode, then press **ACTION**.

### NOTE:

All four arrows can be used to select the SET UP mode, not just ◀.

- 3 Press ▶ and then press ▲ or ▼ to select desired language (e.g. English), then press **ACTION**.
- 4 Press **ACTION** to select the EXIT mode, then press **ACTION** again.

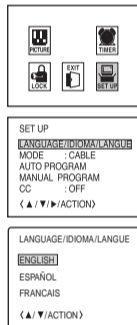

### NOTE:

If Spanish or French is chosen, the Closed Caption indicators will be in the selected language, but the Closed Caption text will not be affected by the language selection.

## TV OPERATION

- 1 To turn on the TV, press **POWER**.
- 2 The VOLUME can be adjusted to a desired level by pressing VOL (VOLUME) ◀ or ▶.  
The sound level will be indicated on the TV screen by GREEN BARS AND A NUMBER. As the sound level increases, so do the number of BARS AND THE NUMBER on the screen. The same is true for decreasing the level.
- 3 Set the TV/CATV menu option to the appropriate position. When shipped from the factory, this menu option is in the CATV setting. See "To Memorize Channels".

TV - VHF/UHF channels  
CABLE - CABLE TV channels

- 4 **CH (CHANNEL) ▲ and ▼**  
Press and release the CH (CHANNEL) ▲ or ▼. The channel automatically stops at the next channel set into memory. Press and hold the button down to change channels more quickly.

For proper operation, before selecting channels, they should be set into the TV's memory. See "To Memorize Channels".

**DIRECT CHANNEL SELECTION (0-9)** - Press these buttons to select a channel. The channel number will appear on the upper right corner of the TV screen. If an invalid channel number is selected, the display will revert to the previous channel.

**TV MODE DIRECT CHANNEL SELECTION** - When the TV/CATV menu option is in the TV position, all channels can be instantly selected by using two buttons (For example, to select channel 2, press "0", then "2". If you press only "2", channel selection will be delayed for a few seconds). For channels 10 and above, press the 2 digits in order.

### CATV mode direct channel selection

When the TV/CATV menu option is in the CATV position, channels can be selected as follows:

- |         |  |
|---------|--|
| 1-9     | Press "0" twice, then 1-9 as needed.<br>Example, to select channel 2, press "002". |
| 10-12   | Press "0", then remaining 2 digits.<br>Example, to select channel 12, press "012". |
| 13-99   | Press the 2 digits in order.<br>Example, to select channel 36, press "36".         |
| 100-125 | Press the 3 digits in order.<br>Example, to select channel 120, press "120".       |

**NOTE:** If the station being viewed stops broadcasting, the TV will automatically shut off after 15 minutes.

## CLOSED CAPTION

### WHAT IS CLOSED CAPTIONING?

This television has the capability to decode and display Closed Captioned television programs. Closed Captioning will display text on the screen for hearing impaired viewers or it will translate and display text in another language.

### TO VIEW CLOSED CAPTIONS

- 1 Press **ACTION** and press ◀ to select the SET UP mode, then press **ACTION**.
- 2 Press ▲ to select CC mode and then press ▶, then press ▲ or ▼ to select desired Closed Caption (e.g. CAPTION CH1), then press **ACTION**.
- 3 Press **ACTION** twice.

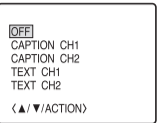

**Captions:** This Closed Caption Mode will display text on the screen in English or another language (depending on the setting of the Closed Captions). Generally, Closed Captions in English are transmitted on Captions Channel 1 and Closed Captions in other languages are transmitted on Captions Channel 2.

**Text:** The Text Closed Caption Mode will usually fill 1/2 of full screen with a programming schedule or other information. After selecting a Closed Caption Mode, it will stay in effect until it is changed, even if the channel is changed. If the Captions signal is lost due to a commercial or a break in the signal, the Captions will reappear when the signal is received again. If the channels are changed, the Captions will be delayed approximately 10 seconds. For television programs broadcasting with Closed Captions, look in your TV guide for the Closed Captions symbol (CC).

- When activating the Closed Captioned Decoder, there will be a short delay before the Closed Captioned text appears on the screen.
- Closed Captioned text is only displayed in locations where it is available.
- If no caption signal is received, no captions will appear, but the television will remain in the Caption Mode.
- Misspellings or unusual characters may occasionally appear during Closed Captioning. This is normal with Closed Captioning, especially with live programs. This is because during live programs, captions are also entered live. These transmissions do not allow time for editing.
- When Captions are being displayed, on-screen displays, such as volume and mute may not be seen or may interfere with Closed Captions.
- Some cable systems and copy protection systems may interfere with the Closed Captioned signal.
- If using an indoor antenna or if TV reception is very poor, the Closed Caption Decoder may not appear or may appear with strange characters or misspelled words. In this case, adjust the antenna for better reception or use an outdoor antenna.

## SETTING LOCK

This TV is fitted with a V-CHIP controller which provides you with channel viewing access controls and restrictions. This function allows adult screening of TV programs based upon ratings.

- 1 Press **ACTION**.
- 2 Press ▼ to select the LOCK mode, then press **ACTION**.
- 3 Enter your password (4 digits) using **Direct channel selection (0-9)**. In the event of entering an incorrect password, press ◀ or wait a few seconds to delete the wrong password.
- 4 Enter the same password for confirmation only for the first time.
- 5 Press ▲ or ▼ to select the V-CHIP option, then press ▶. Press ◀ or ▶ to select the ON, then press **ACTION**.
- 6 Press ▲ or ▼ to select the TV RATING or MOVIE RATING option, then press ▶.
- 7 Press ◀ or ▶ to select the desired rating for the applicable video or TV channel, then press **ACTION**.

### TV RATING

OFF ↔ TV-Y ↔ TV-Y7 ↔ TV-G ↔ TV-PG ↔ TV-14 ↔ TV-MA

TV-Y : all children	TV-PG : parental guidance
TV-Y7 : 7 years old and above	TV-14 : 14 years old and above
TV-G : children's program	TV-MA : 17 years old and above

When you select TV-Y7, TV-PG, TV-14 or TV-MA, press RECALL to explain the rating.

Press ▲ or ▼ to select the desired rating you want. Press ▶ to select the setting ON or OFF, then press **ACTION**.

### MOVIE RATING

OFF ↔ G ↔ PG ↔ PG-13 ↔ R ↔ NC-17 ↔ X

G : all ages	R : Parental guidance for under 17 years old
PG : parental guidance	NC-17 : 17 years old and above
PG-13 : parental guidance for under 13 years old	X : adult only

- 8 Press **ACTION** twice.

### NOTES:

- If you forget your password, turn on the TV. Reduce the volume to a minimum level. Press and hold VOLUME ◀ on the front of the TV and press the 0 button on the remote control simultaneously. Select the LOCK mode, then enter a new password.
- If you want to change the password, follow steps 1-3 and select the "CHANGE PASSWORD" option then enter your new password.
- The V-Chip function is activated only on programs and tapes that have the rating signal.
- Once you block a program using the V-Chip function, the blocked program cannot be watched based on the content of the show. When the program starts, the "INPUT PASSWORD" will appear on the screen. When you want to release the V-Chip temporarily, enter the password. If you change the channel or turn off the TV while the V-Chip function was temporarily released, the original setting will be resumed. If you return to the channel you were watching you must re-enter your password to temporarily release your V-Chip function again.
- If you are changing channels using a VCR or a cable box, while the TV remains on channel 3 or 4, the V-Chip operates differently. When you enter your password to temporarily release the block on any channel, you have completely disabled the V-Chip function for all stations. To reset the V-Chip turn your TV off and back on.
- Some cable boxes are built with a delay feature, in some cases it can take up to 10 seconds for a program to appear after the password has been input.

## TO MEMORIZE CHANNELS

This TV is equipped with a channel memory feature which allows channels to skip up or down to the next channel set into memory, skipping over unwanted channels.

Before selecting channels, they must be programmed into the TV's memory. In addition to normal VHF and UHF channels, this TV can receive up to 113 Cable TV channels. To use this TV with an antenna, set the TV/CATV menu option to the TV setting. When shipped from the factory, this menu option is in the CATV setting.

"TO MEMORIZE CHANNELS" cannot be selected if the AV mode is selected.

### TV/CATV SELECTION

- 1 Press **ACTION** and press **◀** to select the SET UP mode, then press **ACTION**.
- 2 Press **▼** to select MODE mode and then press **▶**. Then press **◀** or **▶** to select the TV or CABLE mode, then press **ACTION**.
- 3 Press **ACTION** twice.

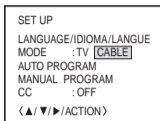
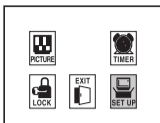

#### NOTE:

Contact your cable company to determine the type of cable system used in your area.

### AUTOMATIC CHANNEL MEMORY

- 1 Press **ACTION** and press **◀** to select the SET UP mode, then press **ACTION**.
- 2 Press **▼** twice to select AUTO PROGRAM mode and then press **▶**. The TV will begin memorizing all the channels available in your area.
- 3 Press **ACTION** twice.

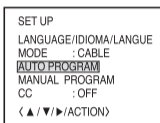

### MANUAL CHANNEL MEMORY

- 1 Press **ACTION** and press **◀** to select the SET UP mode, then press **ACTION**.
- 2 Press **▲** twice to select MANUAL PROGRAM mode and then press **▶**.
- 3 Select the desired channels to be added or deleted using **Direct Channel Selection (10 keys. 0-9), CH ▲** or **▼**.
- 4 Press **◀** or **▶** to select ADD or DELETE.  
If an unmemorized channel was selected (step 3), the channel indicator will be yellow. Press **◀** or **▶** if you wish to ADD the unmemorized channel. The channel indicator will change from yellow to blue when a channel is added and the channel will be memorized. If a memorized channel was selected (step 3), the channel indicator will be blue.  
Press **◀** or **▶** if you wish to DELETE the channel from memory. The channel indicator will change from blue to yellow when a channel is deleted.  
Repeat Steps 3 and 4 for each channel to be added or deleted.
- 5 Press **ACTION** three times.

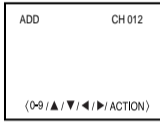
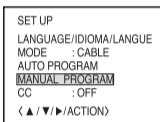

## SETTING TIMER

You can set the TV to turn off after a preset amount time.

- 1 Press **ACTION** and press **▶** to select the TIMER mode, then press **ACTION**.
- 2 Press **▶** and then press **◀** or **▶** to select desired time, then press **ACTION**.

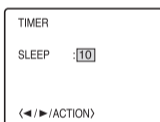

After the timer is programmed, the display will disappear then reappear momentarily every ten minutes to remind you the timer function is operating.

To confirm the timer setting, repeat step 1. The remaining time will be displayed.

To cancel the timer setting, select the OFF.

## ADJUSTING PICTURE

You can adjust the settings for color, sharpness, contrast, brightness and tint.

- 1 Press **ACTION** twice to select the PICTURE mode.
- 2 Press **▲** or **▼** to select desired picture, then press **▶**.
- 3 Press **◀** or **▶** to adjust the setting.

	▶	◀
<b>COLOR</b>	more vibrant color	reduces color
<b>TINT</b>	greenish hue	reddish hue
<b>BRIGHTNESS</b>	increase brightness	decrease brightness
<b>PICTURE</b>	increase contrast	decrease contrast
<b>SHARPNESS</b>	makes picture clearer	makes picture softer

### TO RETURN TO INITIAL SETTING

Select the NORMAL then select SET as in step2.

## CONNECTION TO OTHER EQUIPMENT

The exact arrangement you use to interconnect various video and audio components to the TV is dependent on the model and features of each component. Check the Owner's Manual provided with each component for the location of video and audio inputs and outputs.

The connection diagrams below are offered as suggestions. You may need to modify them to accommodate your particular assortment of components. The diagrams are intended to show component video and audio interconnections only.

Press the **TV/VIDEO** to select the AV mode to use the TV as a monitor.  
Operate your VCR as usual.

#### NOTE:

**TV/VIDEO** only exists in the remote control.

### TV/AV SELECTION

If you connect the TV to a VCR, camcorder or TV game, through the audio/video in jacks, use the **TV/VIDEO** to make your selection.

Press the **TV/VIDEO** repeatedly to select the desired mode.  
"AUX" will display on the screen for 4 seconds.

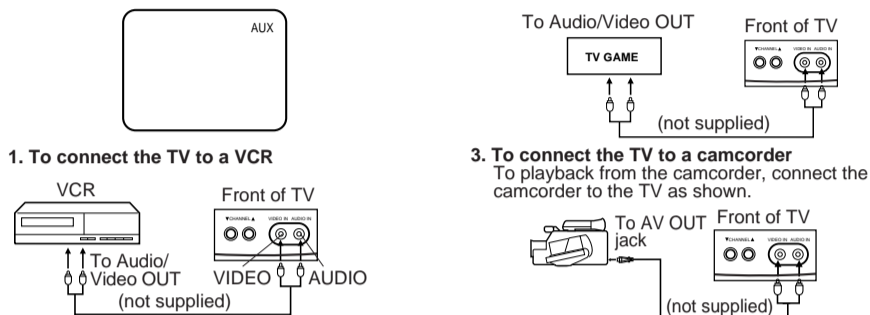

## TROUBLESHOOTING GUIDE

Before requesting service, please refer to the following chart for the symptom and possible solution.

SYMPTOMS	POSSIBLE SOLUTIONS
TV does not operate	<ul style="list-style-type: none"> <li>• Make sure the power cord is plugged in.</li> <li>• Try another AC outlet.</li> <li>• Power is off, check fuse or circuit breaker.</li> <li>• Unplug unit for an hour, then plug it back in.</li> </ul>
Poor sound or No sound	<ul style="list-style-type: none"> <li>• Station or CATV experiencing problems, tune to another station.</li> <li>• Check sound adjustments (VOLUME and MUTE).</li> <li>• Check for sources of possible interference.</li> </ul>
Poor picture or No picture	<ul style="list-style-type: none"> <li>• Station or CATV experiencing problems, tune to another station.</li> <li>• Make sure channels are set into memory.</li> <li>• Check antenna or CATV connections, adjust antenna.</li> <li>• Check for sources of possible interference.</li> <li>• Check picture control adjustments.</li> </ul>
Poor reception on some channels	<ul style="list-style-type: none"> <li>• Station or CATV experiencing problems, tune to another station.</li> <li>• Make sure channels are set into memory.</li> <li>• Station is weak, adjust antenna to receive desired station.</li> <li>• Check for sources of possible interference.</li> </ul>
Poor color or no color	<ul style="list-style-type: none"> <li>• Station or CATV experiencing problems, tune to another station.</li> <li>• Make sure channels are set into memory.</li> <li>• Check picture control adjustments.</li> <li>• Check antenna or CATV connections, adjust antenna.</li> <li>• Check for sources of possible interference.</li> </ul>
Picture wobbles or drifts	<ul style="list-style-type: none"> <li>• Station or CATV experiencing problems, tune to another station.</li> <li>• Make sure channels are set into memory.</li> <li>• CATV company is scrambling signal.</li> <li>• Adjust antenna.</li> </ul>
No CATV reception	<ul style="list-style-type: none"> <li>• Check all CATV connections.</li> <li>• Set TV/CATV menu option to the CATV mode.</li> <li>• Station or CATV system problems, try another station.</li> </ul>
Horizontal or diagonal bars on screen	<ul style="list-style-type: none"> <li>• Check antenna connections, adjust or re-direct antenna.</li> <li>• Check for sources of possible interference.</li> </ul>
No reception above channel 13	<ul style="list-style-type: none"> <li>• Make sure TV/CATV menu option is in the appropriate mode.</li> <li>• If using antenna, check UHF antenna connections.</li> </ul>
No Remote operation	<ul style="list-style-type: none"> <li>• Batteries are weak, dead or inserted incorrectly.</li> <li>• Remote is out of range, move closer to TV (within 15 feet).</li> <li>• Make sure Remote is aimed at sensor.</li> <li>• Confirm there are no obstructions between the Remote and the TV.</li> <li>• Make sure the power cord is plugged in.</li> </ul>
TV shuts off	<ul style="list-style-type: none"> <li>• No broadcast on station tuned.</li> <li>• Timer is set.</li> <li>• Power interrupted.</li> </ul>
Cannot see closed caption	<ul style="list-style-type: none"> <li>• TV station experiencing problems or program tuned is not closed captioned.</li> <li>• Try another channel.</li> <li>• Check CATV connection or VHF/UHF antenna, reposition or rotate antenna.</li> <li>• Select the Closed caption.</li> </ul>
Display is not shown in your language	<ul style="list-style-type: none"> <li>• Select proper language in the SET UP mode.</li> </ul>

## SPECIFICATIONS

AC Power Input:	120V, 60Hz
AC Power Consumption:	54 Watts
Chassis Construction:	IC Solid state
Picture Tube:	13" (measured diagonally)
Horizontal resolution:	260 lines
Audio Power Output Rating:	1.0 Watts
Speaker:	1-1/2"x2-1/2" Full Range, 8 ohm
Tuner Type:	181 Channel, Quartz PLL Frequency Synthesized
Remote Control:	Infrared, Direct Access, 2 x AA batteries (not supplied)
Receiving Channels:	VHF 2-13 UHF 14-69 CATV 1-125
Antenna Input Impedance:	75 Ohm (VHF/UHF/CATV) Coaxial Input
Input:	Video: 1.0 Vp-p 75 ohm Audio: 300 mV, 47k ohm
Dimensions:	14-1/8" (W) x 13-15/16" (D) x 13-1/4" (H)
Weight:	20.9 lbs