

JVC

REVISED

SERVICE MANUAL

REAR PROJECTION TELEVISION

**HD-52Z575,
HD-52Z585,
HD-61Z575,
HD-61Z585**

BASIC CHASSIS

RP2



HD-ILA™
Powered by **DILA**

D.I.S.T.
Digital Image Scaling Technology

BBE

HDMI™
HIGH-DEFINITION MULTIMEDIA INTERFACE

TABLE OF CONTENTS

1	PRECAUTIONS	1-3
2	SPECIFIC SERVICE INSTRUCTIONS	1-7
3	DISASSEMBLY	1-11
4	ADJUSTMENTS	1-23
5	TROUBLESHOOTING	1-34

SPECIFICATION

Items	Contents	
	HD-52Z575 HD-52Z585	HD-61Z575 HD-61Z585
Dimensions (W x H x D)	126.4cm x 91.4cm x 41.2cm (49-7/8" x 36 x 16-1/4")	145.6cm x 104.2cm x 47cm (57-3/8" x 41 x 18-1/2")
Mass	37.8kg (84lbs)	44.3kg (98lbs)
TV RF System	CCIR (M)	
Color System	NTSC	
Sound System	BTSC (Multi Channel Sound)	
Teletext System	Closed Caption (T1-T4 / CC1-CC4)	
TV Receiving Channels and Frequency	VHF Low	54MHz~88MHz (02ch~06ch)
	VHF High	174MHz~216MHz (07ch~13ch)
	UHF	470MHz~806MHz (14ch~69ch)
	CATV	54MHz~804MHz Low Band : 02~06 by 02~06 High Band : 07~13 by 07~13 Mid Band : A~I by 14~22 Super Band : J~W by 23~36 Hyper Band : W+1~W+28 by 37~64 Ultra Band : W+29~W+84 by 65~94, 100~125 Sub Mid Band : A-8, A-4~A-1 by 01, 96~99
TV / CATV Total Channel	180 Channels	
Intermediate Frequency	Video IF	45.75MHz
	Sound IF	41.25MHz (4.5MHz)
Color Sub Carrier	3.58MHz	
Power Input	AC120V, 60Hz	
Power Consumption	195W (Max)	
Projection Source	110W High-pressure mercury lamp	
Projection Device	D-ILA device (Reflection active matrix type LCD) x 3(R / G / B)	
Resolution	Total=H:1312 x V:800 [Effective =H:1280 x V:720]	
Screen	Transparent screen (unitized fresnel lens / lenticular lens), aspect ratio 16:9	
Screen Size	52" (132cm) Measured diagonally H:115.1cm(45-3/8") x V:64.8cm(25-5/8")	61" (155cm) Measured diagonally H:135cm(53-1/4") x V:76cm(30")
Speaker	10cm round x 2 (Oblique corn)	
Audio Power Output	10W+10W	
Antenna Terminal (VHF/UHF)	75Ω unbalanced, coaxial, F-type connector x 1	
External Input [INPUT-1/2/3/4]	Video	1V(p-p), 75 Ω, negative sync (RCA pin jack x 4)
	Audio	500mV(rms) (-4dBs), high impedance (RCA pin jack x 8)
	S-Video [INPUT-1/3/4]	Mini-DIN 4pin connector x 3 Y: 1V(p-p), positive, 75Ω, negative sync C: 0.286V(p-p) (burst signal)
Component Video [INPUT-1/2]	720p/1080i	RCA pin jack x 6 Y: 1V(p-p), (Sync signal : ±0.35V, 3-value sync.), 75Ω Pb/Pr : ±0.35V, 75Ω
	480p/480i	Y: 1V(p-p), positive (negative sync), 75Ω Pb/Pr : 0.7V(p-p), 75Ω
Digital Input	Video	HDMI connector x 1 (This Digital-in terminal is not compatible with picture signals of personal computer.)
	Audio	HDMI connector Digital : HDMI connector Analog : 500mV(rms) (-4dBs), high impedance (RCA pin jack x 2)
Audio Output (VARI/FIX)	VARI : More than 0 to 1000mV(rms) (+2.2dBs) FIX : 500mV(rms) (-4dBs), low impedance (1kHz when modulated 100%) (RCA pin jack x 2)	
Sub woofer Output	More than 0 to 1000mV(rms) (+2.2dBs) (RCA pin jack x1)	
Center channel Input	500mV(rms) (-4dBs), high impedance (RCA pin jack x1)	
AV Compulink III	3.5mm mini jack x 1	
Remote Control Unit	RM-C15G (AA/R6/UM-3 battery x 2)	

Design & specifications are subject to change without notice.

SECTION 1 PRECAUTIONS

1.1 SAFETY PRECAUTIONS

- (1) The design of this product contains special hardware, many circuits and components specially for safety purposes. For continued protection, no changes should be made to the original design unless authorized in writing by the manufacturer. Replacement parts must be identical to those used in the original circuits. Service should be performed by qualified personnel only.
- (2) Alterations of the design or circuitry of the products should not be made. Any design alterations or additions will void the manufacturer's warranty and will further relieve the manufacturer of responsibility for personal injury or property damage resulting therefrom.
- (3) Many electrical and mechanical parts in the products have special safety-related characteristics. These characteristics are often not evident from visual inspection nor can the protection afforded by them necessarily be obtained by using replacement components rated for higher voltage, wattage, etc. Replacement parts that have these special safety characteristics are identified in the parts list of Service manual. **Electrical components having such features are identified by shading on the schematics and by (Δ) on the parts list in Service manual.** The use of a substitute replacement which does not have the same safety characteristics as the recommended replacement part shown in the parts list of Service manual may cause shock, fire, or other hazards.
- (4) **Use isolation transformer when hot chassis.**
The chassis and any sub-chassis contained in some products are connected to one side of the AC power line. An isolation transformer of adequate capacity should be inserted between the product and the AC power supply point while performing any service on some products when the HOT chassis is exposed.
- (5) **Don't short between the LIVE side ground and ISOLATED (NEUTRAL) side ground or EARTH side ground when repairing.** Some model's power circuit is partly different in the GND. The difference of the GND is shown by the LIVE : (⊥) side GND, the ISOLATED(NEUTRAL) : (↷) side GND and EARTH : (⊕) side GND. Don't short between the LIVE side GND and ISOLATED(NEUTRAL) side GND or EARTH side GND and never measure with a measuring apparatus (oscilloscope etc.) the LIVE side GND and ISOLATED(NEUTRAL) side GND or EARTH side GND at the same time.
If above note will not be kept, a fuse or any parts will be broken.
- (6) The high voltage applied to the picture tube must conform with that specified in Service manual. Excessive high voltage can cause an increase in X-Ray emission, arcing and possible component damage, therefore operation under excessive high voltage conditions should be kept to a minimum, or should be prevented. If severe arcing occurs, remove the AC power immediately and determine the cause by visual inspection (incorrect installation, cracked or melted high voltage harness, poor soldering, etc.). To maintain the proper minimum level of soft X-Ray emission, components in the high voltage circuitry including the picture tube must be the exact replacements or alternatives approved by the manufacturer of the complete product.
- (7) If any repair has been made to the chassis, it is recommended that the B1 setting should be checked or adjusted (See ADJUSTMENT OF B1 POWER SUPPLY).
- (8) Do not check high voltage by drawing an arc. Use a high voltage meter or a high voltage probe with a VTVM. Discharge the picture tube before attempting meter connection, by connecting a clip lead to the ground frame and connecting the other end of the lead through a 10kΩ 2W resistor to the anode button.
- (9) When service is required, observe the original lead dress. Extra precaution should be given to assure correct lead dress in the high voltage circuit area. Where a short circuit has occurred, those components that indicate evidence of overheating should be replaced. Always use the manufacturer's replacement components.

(10) Isolation Check

(Safety for Electrical Shock Hazard) After re-assembling the product, always perform an isolation check on the exposed metal parts of the cabinet (antenna terminals, video/audio input and output terminals, Control knobs, metal cabinet, screwheads, earphone jack, control shafts, etc.) to be sure the product is safe to operate without danger of electrical shock.

a) Dielectric Strength Test

The isolation between the AC primary circuit and all metal parts exposed to the user, particularly any exposed metal part having a return path to the chassis should withstand a voltage of 1100V AC (r.m.s.) for a period of one second.

(. . . Withstand a voltage of 1100V AC (r.m.s.) to an appliance rated up to 120V, and 3000V AC (r.m.s.) to an appliance rated 200V or more, for a period of one second.)

This method of test requires test equipment not generally found in the service trade.

b) Leakage Current Check

Plug the AC line cord directly into the AC outlet (do not use a line isolation transformer during this check.). Using a "Leakage Current Tester", measure the leakage current from each exposed metal part of the cabinet, particularly any exposed metal part having a return path to the chassis, to a known good earth ground (water pipe, etc.). Any leakage current must not exceed 0.5mA AC (r.m.s.). However, in tropical area, this must not exceed 0.2mA AC (r.m.s.).

• Alternate Check Method

Plug the AC line cord directly into the AC outlet (do not use a line isolation transformer during this check.). Use an AC voltmeter having 1000Ω per volt or more sensitivity in the following manner. Connect a 1500Ω 10W resistor paralleled by a 0.15μF AC-type capacitor between an exposed metal part and a known good earth ground (water pipe, etc.). Measure the AC voltage across the resistor with the AC voltmeter. Move the resistor connection to each exposed metal part, particularly any exposed metal part having a return path to the chassis, and measure the AC voltage across the resistor. Now, reverse the plug in the AC outlet and repeat each measurement. Any voltage measured must not exceed 0.75V AC (r.m.s.). This corresponds to 0.5mA AC (r.m.s.).

However, in tropical area, this must not exceed 0.3V AC (r.m.s.). This corresponds to 0.2mA AC (r.m.s.).

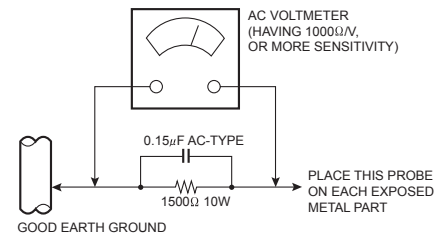

(11) High voltage hold down circuit check.

After repair of the high voltage hold down circuit, this circuit shall be checked to operate correctly.

See item "How to check the high voltage hold down circuit".

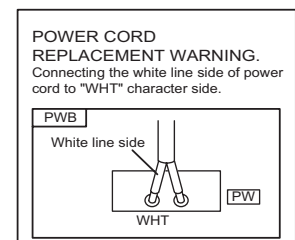
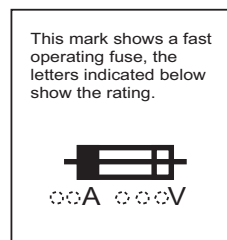

1.2 INSTALLATION

1.2.1 HEAT DISSIPATION

If the heat dissipation vent behind this unit is blocked, cooling efficiency may deteriorate and temperature inside the unit will rise. The temperature sensor that protects the unit will be activated when internal temperature exceeds the predetermined level and power will be turned off automatically.

Therefore, please make sure pay attention not to block the heat dissipation vent as well as the ventilation outlet behind the unit and ensure that there is room for ventilation around it.

- ⚠ **Do not put foreign objects near the ventilation holes as this can result in fire or electrical hazards.**
- ⚠ **Do not block the ventilation holes as this may cause the internal temperature to rise and possibly result fire.**

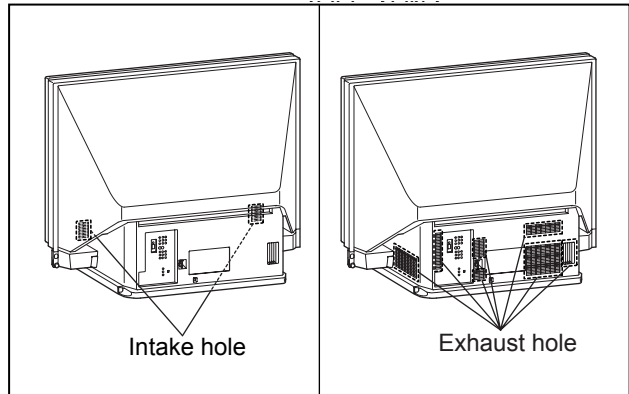

VENTILATION POSITION

1.2.2 INSTALLATION REQUIREMENTS

Ensure that the minimal distance is maintained, as specified below, between the unit with and the surrounding walls, as well as the floor etc.

Install the unit on stable flooring.

Take precautionary measures to prevent the unit from tipping in order to protect against accidents and earthquakes.

CAUTION FOR INSTALLATION

- Do not tilt the TV towards the left or right, or toward the back.
- Install the TV in a corner on the floor so as to keep cords out of the way.
- The TV will generate a slight amount of heat during operation. Ensure that sufficient space is available around the TV to allow satisfactory cooling.

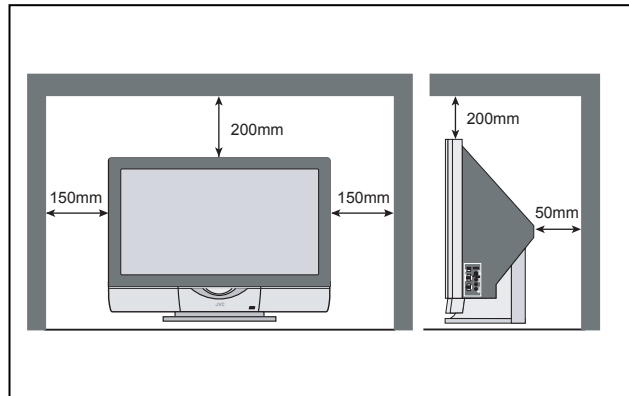

1.3 LAMP UNIT HANDLING CAUTION

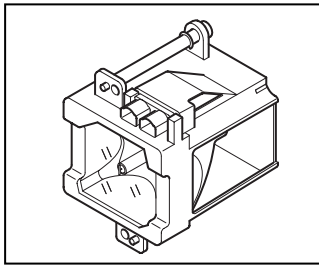

LAMP UNIT : TS-CL110UAA

1.3.1 PRECAUTION FOR LAMP UNIT

- ⚠ The lamp emits high intensity white, ultraviolet and infrared light. Do not look directly at the light during service. Also, do not touch the lamp directly as it presents a burn hazard.
- ⚠ Handle with extra care. This lamp emits high heat and contains high-pressure during use.
- ⚠ Do not give any impact as this may cause the broken lamp.

1.3.2 HOW TO CONFIRM LAMP OPERATING TIME

- (1) Set to 0 minutes using the [SLEEP TIMER] key.
- (2) Press the [VIDEO STATUS] key and [DISPLAY] key simultaneously, then enter the SERVICE MODE.
- (3) When the Main Menu is displayed, press [4] key to enter the setting display for designing.
- (4) Press [CH+] / [CH-] key to select the addresses (items).

NOTE :

- Confirmation of the information can be done by selecting addresses (items) below.
Display position is in the far right side in the 2nd row from the top, as displayed below.

1.3.3 LAMP OPERATING TIME

- MAXIMUM COUNT TIME : 65535 hours

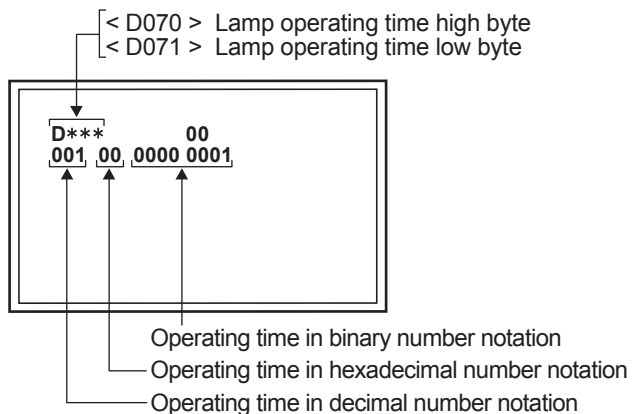

1.3.4 LAMP UNIT REPLACEMENT

- (1) The lamp replacement message will appear when need to change the lamp. After replace the lamp, need to reset the timer which is built into TV.
- (2) Life of the lamp unit is about 5000 hours over. Lamp use time can be check at the lamp message MENU.
- (3) If Fig.1 message appears when turn the TV on, need to replace the lamp.
- (4) Use the lamp timer reset only after replacing the lamp.

NOTE :

- This message will appear every time turn on the TV, when the lamp needs to be replaced. Press the [OK] key to make the message disappear, or replace the lamp.

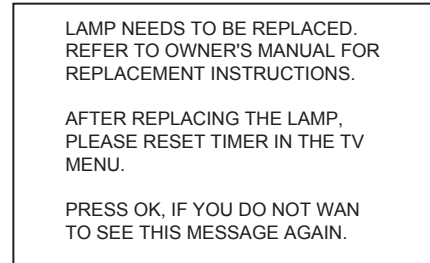

Fig.1 LAMP REPLACEMENT MESSAGE

1.3.5 HOW TO REPLACE THE LAMP UNIT

- Refer to the [USERS GUIDE] for a detailed operating description.
- (1) Turn off the TV power with power key.
 - (2) Disconnect the power cord from the AC outlet.
 - (3) Loosen 1 screw from the rear side, then take out the the left speaker panel.
 - (4) Loosen 1 screw then take out the lamp cover.
 - (5) Loosen 2 screws then take out the lamp unit.
 - (6) Install the new lamp unit.
 - (7) Re-install the lamp cover.
 - (8) Re-install the left speaker panel.
 - (9) Re-install the screw to the rear panel.

NOTE :

- After installing the new lamp unit, do not forget to reset the lamp timer.

1.3.6 HOW TO RESET THE LAMP TIMER

- Refer to the [USERS GUIDE] for a detailed operating description.
- (1) Press the [MENU] key to select CLOCK / TIMERS.
 - (2) Select the <LAMP TIMER RESET> with [▲] / [▼] keys.
 - (3) Enter the <LAMP TIMER RESET> mode the message will appears.
 - (4) Press the [OK] key while the above message appears on the screen.
 - (5) Turn off the power, then turn on the power.
 - (6) The lamp timer has now been reset, as before the 1.3.2 HOW TO CONFIRMATION LAMP OPERATING TIME.

1.3.7 PRECAUTION FOR REPLACEMENT

- Do not replace the LAMP UNIT immediately after the projector has been used.
- The temperature of the LAMP UNIT is still high and could cause a burn.
- Allow a cooling period of 1 hour or more before performing replacement.
- Before starting LAMP UNIT replacement work, turn off the MAIN POWER switch, and disconnect the AC power cord plug from the wall outlet.
- If touched, the lamp glass surface may rupture and burns may result. Do not touch the glass portion or metal portion. Handle only plastic handle.
- The replaced old lamp can be discarded in the same manner as a fluorescent lamp. Check local ordinances and dispose of the used lamp as prescribed.

1.4 SERVICE PARTS KIT INSTRUCTIONS

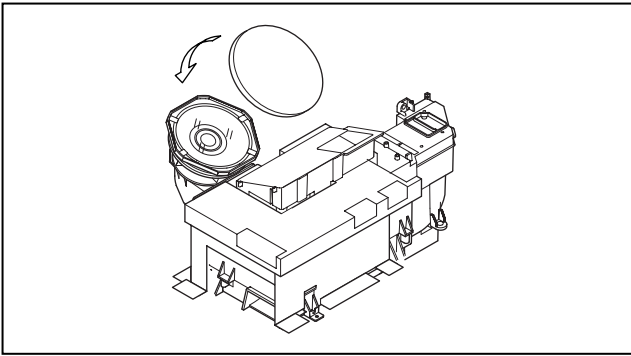

OPTICAL / DRIVE ASS'Y : TS-COP5A-SAA

Due to the character of this product, these **OPTICAL / DRIVE ASS'Y** are prepared.
Please note these **OPTICAL /DRIVE ASS'Y** when replacing or ordering the parts.

1.4.1 PART NUMBER AND CONSTRUCTION

Kit parts number	Kit part name
TS-COP5A-SAA	OPTICAL / DRIVE ASS'Y

1.4.2 OPTICAL / DRIVE ASS'Y CONSTRUCTION

- (1) OPTICAL BLOCK
(Included HD-ILA DEVICE, PROJECTION LENS)
- (2) OPTICAL BASE
- (3) MAIN DRIVE PWB ASS'Y
This PWB is mounted with 2 memory ICs saved with adjustment, setting data of the drive circuit.
- (4) SHIELD TAPE

* The following parts are not included in the kit.

- 1) REMOTE SENSOR PWB ASS'Y
- 2) FAN CONTROL PWB ASS'Y
- 3) LAMP UNIT
- 4) FRONT SHADE BRACKET
- 5) SHADE COVER

1.4.3 PRECAUTION FOR USING

- (1) In the case of the following defects/problems, replace this kit (OPTICAL/DRIVE ASS'Y)
 - 1) Picture defect caused by optical system/D-ILA device related parts.
 - 2) Picture defect caused by drive circuit.
- (2) The MAIN DRIVE PWB ASS'Y is mounted with 2 memory ICs [IC3741/IC3742] saved with adjustment/setting data (GAMMA, SHADING, etc.) of the drive circuit.
The data of this memory IC is in the optimal state according to individual D-ILA devices and each section of the OPTICAL BLOCK.
- (3) When replace the MAIN DRIVE PWB ASS'Y, take off the 2 memory ICs from the original board and replace with new one. When replace the MAIN DRIVE PWB ASS'Y, do same manner. Replace 2 memory ICs.
- (4) When installing this kit (OPTICAL/DRIVE ASS'Y) to the set, first mount the FRONT SHADE BRACKET and SHADE COVER (with cushion) to the kit (lens section).
- (5) After the replacement of the OPTICAL BLOCK, projection lens focus adjustment and drive convergence / projection adjustment are required.

1.5 SCREEN HANDLING CAUTIONS

1.5.1 SCREEN STORAGE

Store the **SCREEN ASS'Y** in a standing position in order to avoid deformation. If the screen is stored horizontally, there is risk of deforming the screen face.

When necessary to place the **SCREEN ASS'Y** horizontally, position the screen side upwards and sure to place spacers between the screen and resting site (floor or stand etc.) to prevent the screen from sagging.

1.5.2 SCREEN SURFACE

Since the screen surface is easily scratched or soiled, use ample care when handling.

1.5.3 PRECAUTIONS FOR CLEANING AND REPLACEMENT

- The **SCREEN ASS'Y** is made from the lenticular lens and fresnel lens.
The anti static proceeding and the surface of the lenticular lens. Rubbing the surface with something hard, the coating may peel off.
- When the screen is dirty, gently wipe it with a soft cloth.
If the screen is very dirty, wipe it down with a cloth dipped in a diluted kitchen cleaner (neutrality detergent) and thoroughly wrung-out.
Then wipe immediately after with clean, dry cloth.
Never use the organic solvent such as the alcohol or benzine.
- The **SCREEN ASS'Y** replacement is required if the coating was peel off.
Alkaline detergent or acidity detergent can not be used.
- The notched side of the lenticular lens and the fresnel lens are faced each other.
- Do not rub the screen when cleaning it or replacing it.
Rubbing the screen may cause of the scratch of the screen by its notch.

SECTION 2 SPECIFIC SERVICE INSTRUCTIONS

2.1 TECHNICAL INFORMATION

2.1.1 DIFFERENCE LIST

Items	HD-52Z575 / HD-61Z575	HD-52Z585 / HD-61Z585
SMART SOUND	Non	Built-in
SMART CAPTION	Non	Built-in
FRONT CABINET	Silver	Black

2.1.2 PROJECTION UNIT

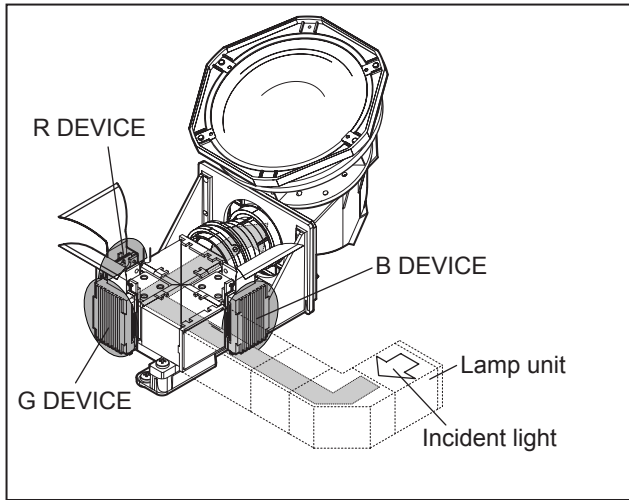

2.1.5 D-ILA DEVICE STRUCTURE

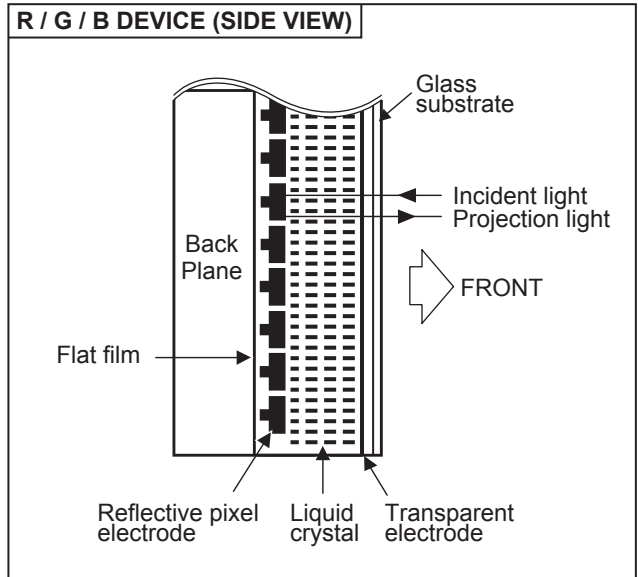

2.1.3 IMAGE LIGHT FLOW

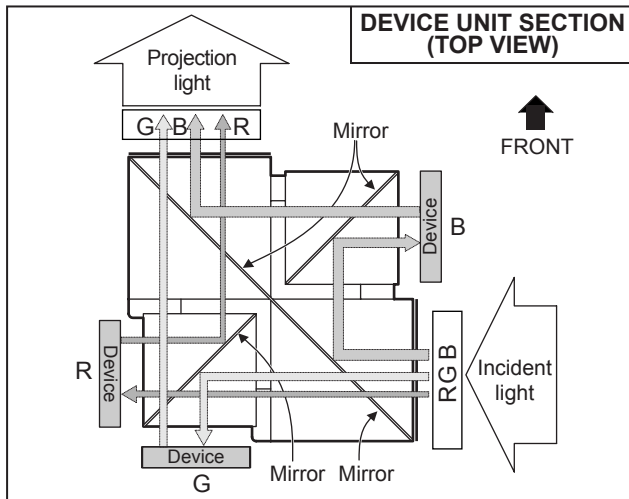

PIXEL VIEW (FRONT VIEW)

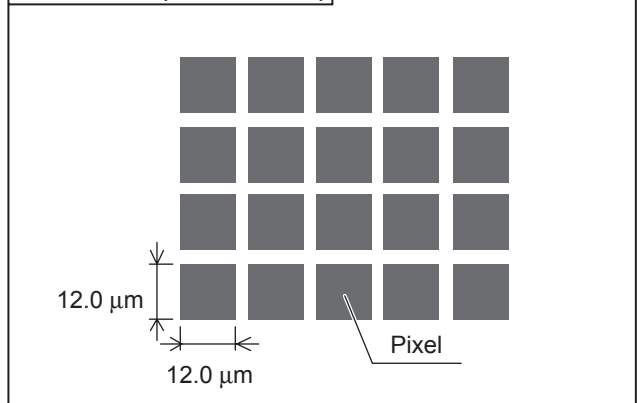

2.1.4 D-ILA DEVICE SPECIFICATION

Item	Content
Resolution	H:1312 x V:800
Pixel number	about 3200000
Pixel size	H :12.0μm x V :12.0μm
Aspect ratio	16 : 9
Contrast ratio	1000 : 1
Aperture ratio	93% or more
Effective pixel measurement	0.7 inch

2.1.6 MAIN CPU PIN FUNCTION (IC7601 : M306V7FGF-088FP) [DIGITAL SIGNAL PWB ASS'Y]

Pin	Port	Pin name	I/O	Function
1	VHOLD1	VHOLD1	I	Data slice for main screen closed caption
2	HFLT1	HFLT1	I/O	LPF for main screen closed caption video input
3	P9.4		O	Not used
4	P9.3		O	Not used
5	P9.2	DIGRO	O	R [0] for OSD
6	P9.1	TB1IN	I	AC power for timer clock
7	P9.0	REMO	I	Remote control
8	BYTE	BYTE	I	Data bus width select [L = 16bit (fixed)]
9	CNVss	CNVss	I	CPU programming mode select [Normal = L]
10	P8.7	DIGGO	O	G [0] for OSD
11	P8.6	DIGBO	O	B [0] for OSD
12	RESET	RESET	I	Reset for main CPU [Reset = L]
13	XOUT	XOUT	O	System clock osillation (crystal) : 16MHz
14	Vss	Vss	-	GND
15	XIN	XIN	I	System clock osillation (crystal) : 16MHz
16	Vccl	Vccl	I	3.3V stand-by power supply
17	OSC1	OSC1	I	Clock for OSD
18	OSC2	OSC2	O	Not used : Clock for OSD
19	P8.3	INT1	I	AV COMPULINK control
20	P8.2	INT0	I	Request for sub(chassis) CPU communication (serial data)
21	OUT1	OUT1	O	Ys (blanking) for OSD
22	OUT2	OUT2	O	YM (transparence) for OSD
23	P7.7		O	Not used
24	P7.6		O	Not used
25	P7.5		O	Not used
26	P7.4		O	Not used
27	P7.3	CTA2/RTS2	O	Not used : Digital tuner control
28	P7.2	CLK2	O	Not used : Digital tuner control
29	P7.1	RxD2	I	Not used : Digital tuner control
30	P7.0	TxD2	O	Not used : Digital tuner control
31	P6.7	SDA2	I/O	Not used
32	DIGR1	DIGR1	O	R [1] for OSD
33	DIGG1	DIGG1	O	G [1] for OSD
34	DIGB1	DIGB1	O	B [1] for OSD
35	P6.3	TxD0	I	Data receive (serial) for external programming
36	P6.2	RxD0	O	Data transmission (serial) for external programming
37	P6.1	CLK0	I	Clock for external programming
38	P6.0	RTSO	O	Busy for external programming [Operation = H]
39	P5.7		I	Not used
40	P5.6		O	Not used
41	HOLD	HOLD	I	CPU programming mode select [Normal = H]
42	P5.4		O	Not used
43	P5.3		O	Not used
44	P5.2		O	Not used
45	P5.1		O	Not used
46	P5.0	WR	O	CPU programming mode select [Normal = L]
47	P4.7	MICON_TX	O	Data transmission for sub(chassis) CPU communication (serial)
48	P4.6	MICON_RX	I	Data receive for sub(chassis) CPU communication (serial)
49	P4.5	MI_CLK	I	Clock for sub(chassis) CPU communication (serial)
50	P4.4		O	Not used

Pin	Port	Pin name	I/O	Function
51	P4.3		O	Not used
52	P4.2		O	Not used
53	P4.1		O	Not used
54	P4.0		O	Not used
55	P3.7		O	Not used
56	P3.6		O	Not used
57	P3.5		O	Not used
58	P3.4		O	Not used
59	P3.3		O	Not used
60	P3.2		O	Not used
61	P3.1		O	Not used
62	HSYNC	HSYNC	I	H. sync for OSD
63	P3.0		O	Not used
64	VSYNC	VSYNC	I	V. sync for OSD
65	P2.7		O	Not used
66	P2.6		O	Not used
67	P2.5		O	Not used
68	P2.4		O	Not used
69	P2.3		O	Not used
70	P2.2		O	Not used
71	P2.1		O	Not used
72	P2.0		O	Not used
73	P1.7		O	Not used
74	P1.6		O	Not used
75	P1.5		O	Not used
76	P1.4		O	Not used
77	P1.3		O	Not used
78	P1.2		O	Not used
79	P1.1		O	Not used
80	P1.0		O	Not used
81	P0.7		O	Not used
82	P0.6		O	Not used
83	P0.5		O	Not used
84	P0.4	WAKE	O	Reset for sub(chassis) CPU
85	P0.3	CARD_DET	I	Not used : Card detection for ATSC digital tuner
86	P0.2	POWER_SW	I	Not used : Power switch (mechanical) detection
87	P0.1	SDA0	I/O	Data for Inter IC (serial) bus control : memory
88	P0.0	SCL0	O	Clock for Inter IC (serial) bus control : memory
89	P10.7	DIGR2	O	R [2] for OSD
90	P10.6	DIGG2	O	G [2] for OSD
91	P10.5	DIGB2	O	B [2] for OSD
92	P10.4		O	Not used
93	P10.3	KEY1	I	Key scan data for front control button (MENU/CH+/CH-) KEY2
94	P10.2	KEY0	I	Key scan data for front control button (VOL+/VOL-) KEY1
95	VHOLD2	VHOLD2	I	Data slice for sub screen closed caption
96	HLF2	HLF2	I/O	LPF for sub screen closed caption video input
97	CVIN2	CVIN2	I	Video(Y) for sub screen closed caption
98	TVSETB	TVSETB	I	Test terminal [L Fixed]
99	VCCE	VCCE	I	5V stand-by power supply
100	CVIN1	CVIN1	I	Video(Y) for main screen closed caption

2.1.7 SUB (CHASSIS) CPU PIN FUNCTION (IC7001 : MN102H60KPA) [DIGITAL SIGNAL PWB ASS'Y]

Pin	Port	Pin name	I/O	Function
1	P60	LB PRO	O	Not use
2	P61	P MU	O	Picture muting [Muting = H]
3	P62/FUNC LED	JP_CSB	O	Not use (NC)
4	P63	A MU	O	Audio muting [Muting = H]
5	P50	M MU	O	Audio muting (for AUDIO OUT) [Muting = H]
6	P51/PC SW	PC SEL	O	Not use : RGB(PC) INPUT select
7	P52/DIMMER LED	ON_TIMER	O	POWER INDICATOR (LED) brightness [LOW = L]
8	P53/BL ON	ILA0	O	Not use : LCD back light lighting
9	P54/BL 5060	ILA1	O	Not use : LCD panel overshoot refresh timing
10	P55	ILA2	O	Not use
11	P56	POW LED	O	POWER LED lighting [ON = H]
12	P57	WORD	O	Not use
13	SBT2	MI_CK	I	Clock for SUB (OSD) CPU communication
14	SBI2	MI_TX	I	Data receive for SUB (OSD) CPU communication
15	SBO2	MI_RX	O	Data transmission for SUB (OSD) CPU communication
16	P23/REQ	MI_REQ	O	Data request for SUB (OSD) CPU communication [Request = L]
17	VDD	3.3V	I	3.3V power supply
18	PB0	FOSC	O	Not use (NC)
19	VSS	GND		Ground
20	XI	3.3V	I	Not use : Low speed oscillator
21	XO		O	Not use : Low speed oscillator
22	VDD	3.3V	I	3.3V power supply
23	OSCI	OSCI	I	System clock oscillation (crystal) : 16MHz
24	OSCO	OSCO	O	System clock oscillation (crystal) : 16MHz
25	MODE	3.3V	I	Single chip mode
26	P24	BS1.5CTL	O	Not use : Digital tuner power / reset control
27	P25	A92 RST	O	Reset for IC1001(3D YC SEP / COLOR DEMODULAT) [Reset = H]
28	P26	BS RST	O	Not use: Reset for Digital tuner power / reset control
29	P27	LIP RST	O	Not use: Reset for Sound delay (Lip sync)
30	KI0	SOFT_OFF	O	Not use
31	KI1	VMUTE	I	No use : Picture muting request from digital tuner
32	KI2	VOUTENB	O	No use : Video cutoff for digital tuner
33	P33	MDR CON	I	No use : System cable connection monitor for PDP
34	AVDD	3.3V	I	3.3V power supply
35	P34		O	Not use : Digital tuner power control
36	P35	DSYNC SW2	O	Sync select for DIGITAL-IN [Controlled with 99-pin]
37	P36	LB_POW	O	Not use : Power control for low bias line
38	P37		O	Not use (NC)
39	P40	HOTPLUG	I	Not use: Video communication monitor for receiver unit (PDP)
40	P41	MECA SW	I	Mechanical monitor for POWER switch [Push = L]
41	P42	MAIN POW	O	Main power control [ON = L]
42	P43	VARI/FIX	O	AUDIO OUT output mode select [VARIABLE = L]
43	VREF-		I	Not use
44	AN4/EE	AFT2	I	Not use : AFT voltage for sub tuner
45	AN5	AFT1	I	AFT voltage for VHF/UHF tuner
46	AN6	KEY2	I	Key scan data for front switc (MENU/CH+/CH-)
47	AN7	KEY1	I	Key scan data for front switch (VOL+/VOL-)
48	P80		O	Not use (NC)
49	P81		O	Not use (NC)
50	TMIO	AC IN	I	AC power pulse for timer clock

Pin	Port	Pin name	I/O	Function
51	SBI3	BS TXD	O	Not use : Data transmission for digital tuner communication
52	SBO3	BS RXD	I	Not use : Data receive for digital tuner communication
53	P85		O	Not use (NC)
54	VREF+	3.3V	I	3.3V power supply
55	SBI4	PDP TX	O	Data transmission for SUB (DRIVE) CPU communication
56	SBO4	PDP RX	I	Data receive for SUB (DRIVE) CPU communication
57	P90	SDA0	I/O	Data for Inter IC (serial) bus : EEP-ROM (IC7002)
58	P91	SCL0	O	Clock for Inter IC (serial) bus : EEP-ROM (IC7002)
59	P92	SDA DVI	I/O	Not use : Data for Inter IC (serial) bus for panel communication
60	P93	SCL DVI	O	Not use : Clock for Inter IC (serial) bus for panel communication
61	AVSS	GND		Ground
62	AN0/DIN PH	DIGI_PHOT	I	Photo sensor for DIGITAL-IN illegal copy protection
63	AN1	ATSC REC	I	Not use
64	AN2		I	Not use
65	AN3		I	Not use
66	VDD	3.3V	I	3.3V power supply
67	P70/DINPRO	DIGI_PRO	O	for DIGITAL-IN (HDMI)
68	P71		O	Not use (NC)
69	P72		O	Not use (NC)
70	P73	SYNC SEL	O	Not use : Sync select for digital tuner
71	SBI1		O	Not use (NC)
72	SBO1		O	Not use (NC)
73	*	SBD5	I/O	Not use : Data for writing on board (connect CN01P : for Frash ROM type)
74	*	SBT5	I	Not use : Clock for writing on board (connect CN01P : for Frash ROM type)
75	NMI	3.3V	I	3.3V power supply
76	IRQ0	COMP	I	AV COMPULINK áV control
77	IRQ1	REMOCON	I	Remote control
78	IRQ2	V SYNC	I	V. sync pulse
79	IRQ3	WAKEUP SHM	I	Reset for sub(chassis) CPU
80	IRQ4	POWERGOOD	I	Power error detection [NG = H]
81	PA5/REC LED	LAMP LED	O	LAMP LED lighting [Lighting = H]
82	VDD	RST	I	Reset for MAIN CPU [Reset = L]
83	RST	3.3V	I	3.3V power supply
84	P00	SCL3A	O	Clock for Inter IC (serial) bus control :
85	P01	SDA3A	I/O	Data for Inter IC (serial) bus control :
86	P02	SCL3B	O	Clock for Inter IC (serial) bus control :
87	P03	SDA3B	I/O	Data for Inter IC (serial) bus control :
88	P04/DIN SEL	DIGI_SYNCSEL	O	Not use
89	P05	LR SW	O	for DIGITAL-IN (HDMI)
90	P06/DIN INT	DIGI_INT	I	Reset for HDMI process [Reset =]
91	P07	DVI RST	O	Not use : Reset for DVI format conversion
92	VSS	GND		Ground
93	P10	SCL5055	O	Clock for Inter IC (serial) bus : JCC5055 (DIST process)
94	P11/BS CLK SEL	VFORMATSEL	O	Not use : Digital tuner clock control
95	P12	SDA5055	I/O	Data for Inter IC (serial) bus : JCC5055 (DIST process)
96	P13	OSD MODE SEL	O	Not use : OSD mode select
97	P14		O	Not use (NC)
98	P15	15K/OTH	O	Main video select [Fixed H]
99	P16	DSYNC SW1	O	Syncselect for DIGITAL-IN [Controlled with 36-pin]
100	P17	JCC5057 BUSY	I	Busy monitor for JCC5057 (New DIST process)

2.1.8 SYSTEM RESET

When the DIGITAL SIGNAL PWB is replaced or the DIGITAL INPUT is not normal, reset the SYSTEM SETTING using the following procedure.

- (1) Set to 0 minutes using the [SLEEP TIMER] key.
- (2) Press the [VIDEO STATUS] key and [DISPLAY] key simultaneously to enter the SERVICE MODE.
- (3) When the Service Menu is displayed, press [2] key to enter the self check mode.
- (4) Turn off the power by pressing the [POWER] key on the remote control unit.

When DIGITAL INPUT does not function normal using the method above mentioned, perform the following operation.

[Remote control unit (with LC display) [LP20873-009] will be required for this operation.]

- (1) Take out the batteries from the remote control unit.
- (2) Insert the batteries while pressing and holding [4], [5] and [6] keys simultaneously.
- (3) While viewing the LC display of the remote control unit (LP20873-009), set the value to [0] using the [START DEBUT +] / [START DEBUT -] keys.
- (4) In the same manner, set the value to [3] using the [STOP FIN +] / [STOP FIN -] keys.
- (5) In the same manner, set the value to [6] using the [DATE +] / [DATE -] keys.
- (6) In the same manner, set the value to [C] using the [PR +] / [PR -] keys.
- (7) When completed with all of the above settings, press the [Transmission] key.

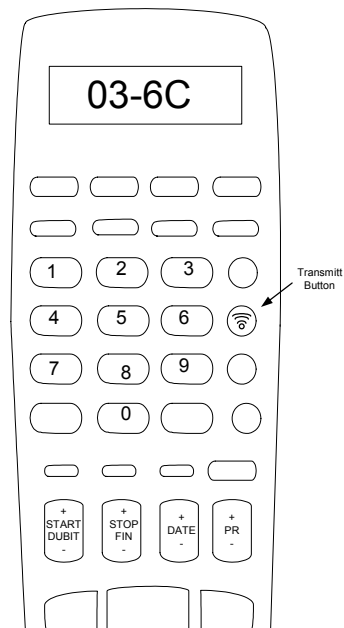
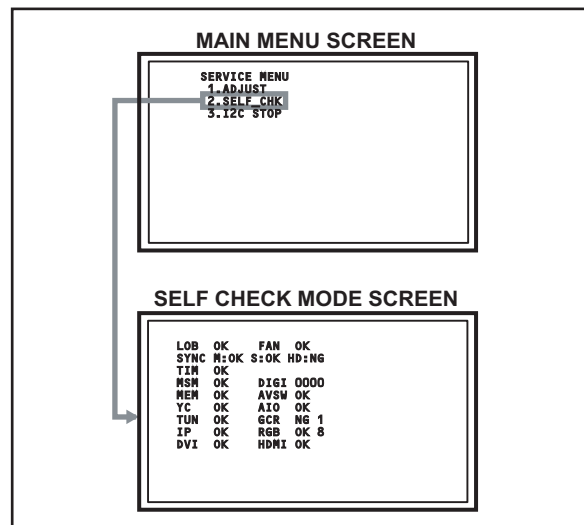

SECTION 3 DISASSEMBLY

3.1 DISASSEMBLY PROCEDURE

- Make sure that the power cord plug is pull out from the AC wall outlet.
- Wait until the LAMP UNIT has cool down is completely.
- While not in repair service, place the chassis back its original position.

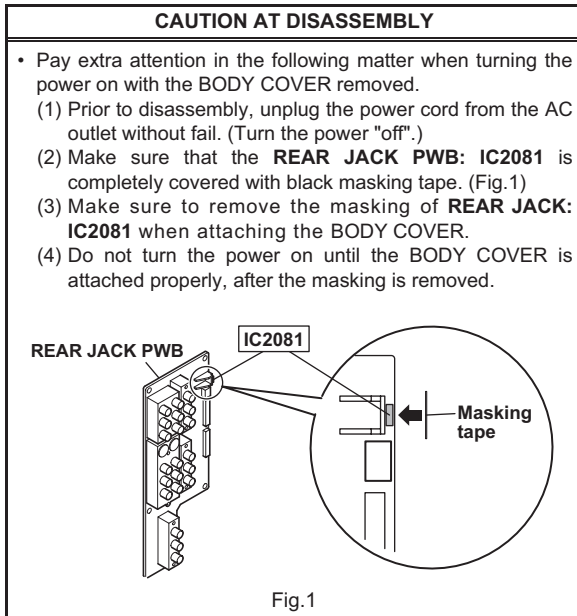

<FRONT SIDE>

3.1.1 SPEAKER GRILL (L & R)

- (1) Remove 1 screw [A] from right rear side.
- (2) Remove 1 screw [B] from left rear side.
- (3) Take out the SPEAKER GRILL (L& R).

3.1.2 SPEAKER

- Take out the SPEAKER GRILL.
 - (1) Remove 4 screws [C].
 - (2) Take out the SPEAKER.
- * Remove the both side SPEAKER same manner.

3.1.3 FRONT PANEL

- Take out the SPEAKER GRILL.
 - (1) Remove 4 screws [D].
 - (2) Take out the FRONT PANEL.

3.1.4 LAMP COVER

- Take out the SPEAKER GRILL of LEFT SIDE.
 - (1) Remove 1 screw [E].
 - (2) Take out the LAMP COVER.

NOTE :

- Do not leave the LAMP COVER removed for long time to prevent dirt and dust form covering the lens.
- Make sure that the LAMP COVER is completely installed.

3.1.5 FRONT LED PWB

- Take out the SPEAKER GRILL.
- Take out the FRONT PANEL.
 - (1) Remove 2 screws [F] from rear side of FRONT PANEL.
 - (2) Take out the FRONT LED PWB.

3.1.6 FILTER COVER

- Take out the SCREEN BLOCK.
 - (1) Remove 2 screws [G].
 - (2) Take out the FILTER COVER.
 - Remove the both side FILTER COVER same manner.

3.1.7 CENTER COVER

- Take out the SPEAKER GRILL.
- Take out the FRONT PANEL.
 - (1) Remove 2 screws [H].
 - (2) Take out the CENTER COVER.

3.1.8 SCREEN BLOCK

- Take out the SPEAKER GRILL.
- Take out the FRONT PANEL.
 - (1) Remove the 4 screws [I].
 - (2) Remove 10 screws [J] from rear side.
 - (3) Take out the SCREEN BLOCK.

CAUTION :

- Place the SCREEN BLOCK on a flat table without fail.
- Because of the large size, at least 2 parsons are recommended for removal and reassemble.
- Use care not to scratch the screen during work.
- During assembly, be sure to engage the left and right tabs with the cabinet mounting positions.
- When supporting the SCREEN BLOCK, avoid grasping the top of the screen panel, instead grasp the left and right areas.
- Do not leave the SCREEN BLOCK removed for long time to prevent soiling from dust.

3.1.9 SCREEN ASS'Y

- Take out the SCREEN BLOCK.

[HD-52Z575 / HD-52Z585]

 - (1) Remove 20 screws [K] from FRONT CABINET.

[HD-61Z575 / HD-61Z585]

 - (1) Remove 24 screws [K] from FRONT CABINET.
 - (2) Take out the SCREEN ASS'Y.

3.1.10 FRONT PANEL

- Take out the SCREEN BLOCK.

[HD-52Z575 / HD-52Z585]

 - (1) Remove 16 screws [L] from FRONT CABINET.

[HD-61Z575 / HD-61Z585]

 - (1) Remove 20 screws [L] from FRONT CABINET.
 - (2) Take out the FRONT PANEL.

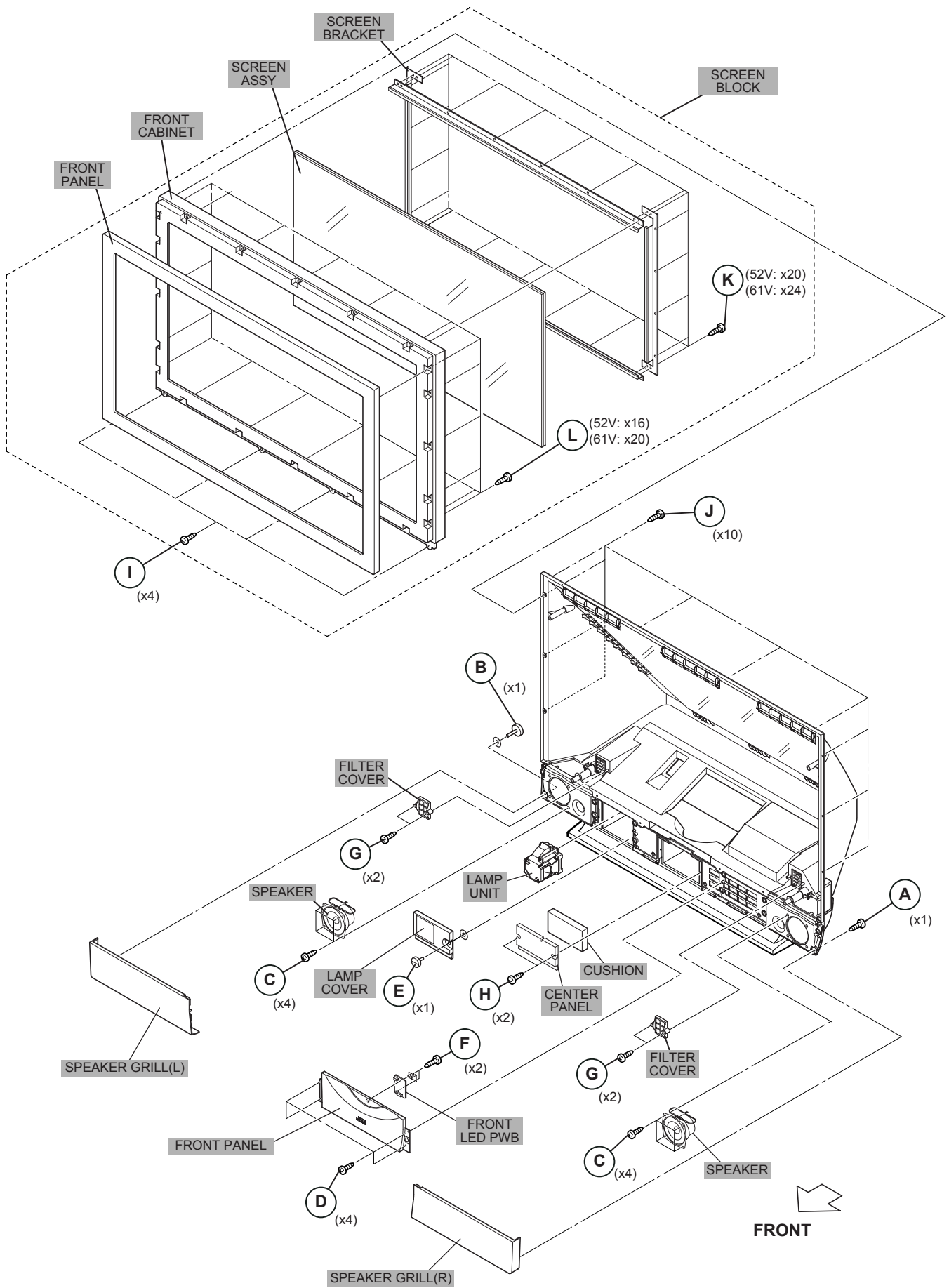

<FRONT INNER SIDE>

3.1.11 MIRROR

- Take out the SPEAKER GRILL both side.
- Take out the FRONT PANEL.
- Take out the SCREEN BLOCK.
- (1) Remove 12 screws [A] attaching the MIRROR HOLDER of the upper, left and right side.
- (2) Raise slightly to disengage of the MIRROR from the bottom holder.
- (3) Take out the MIRROR.

NOTE :

- Do not touch the front of the MIRROR.
- Do not shock the front of the MIRROR.
- Because of the large size, at least 2 persons are recommended for removal and reassemble.

3.1.12 SIDE CONTROL BASE

- Take out the SCREEN BLOCK.
- (1) Remove 4 screws [B].
- (2) Take out the SIDE CONTROL BASE.

3.1.13 SIDE CONTROL PWB

- Take out the SCREEN BLOCK.
- Take out the SIDE CONTROL BASE.
- (1) Remove 4 screws [C] from rear side of SIDE CONTROL BASE.
- (2) Take out the SIDE CONTROL PWB.

3.1.14 BACK COVER

- Take out the FRONT PANEL.
- Take out the SCREEN BLOCK.
- (1) Remove 13 screws [D].
- (2) Remove 2 screws [E] from rear side.
- (3) Slightly pull for backside to disengage of the BACK COVER from hooks.
- (4) Take out the BACK COVER.

NOTE :

- Because of the large size, at least 2 persons are recommended for removal and reassemble.

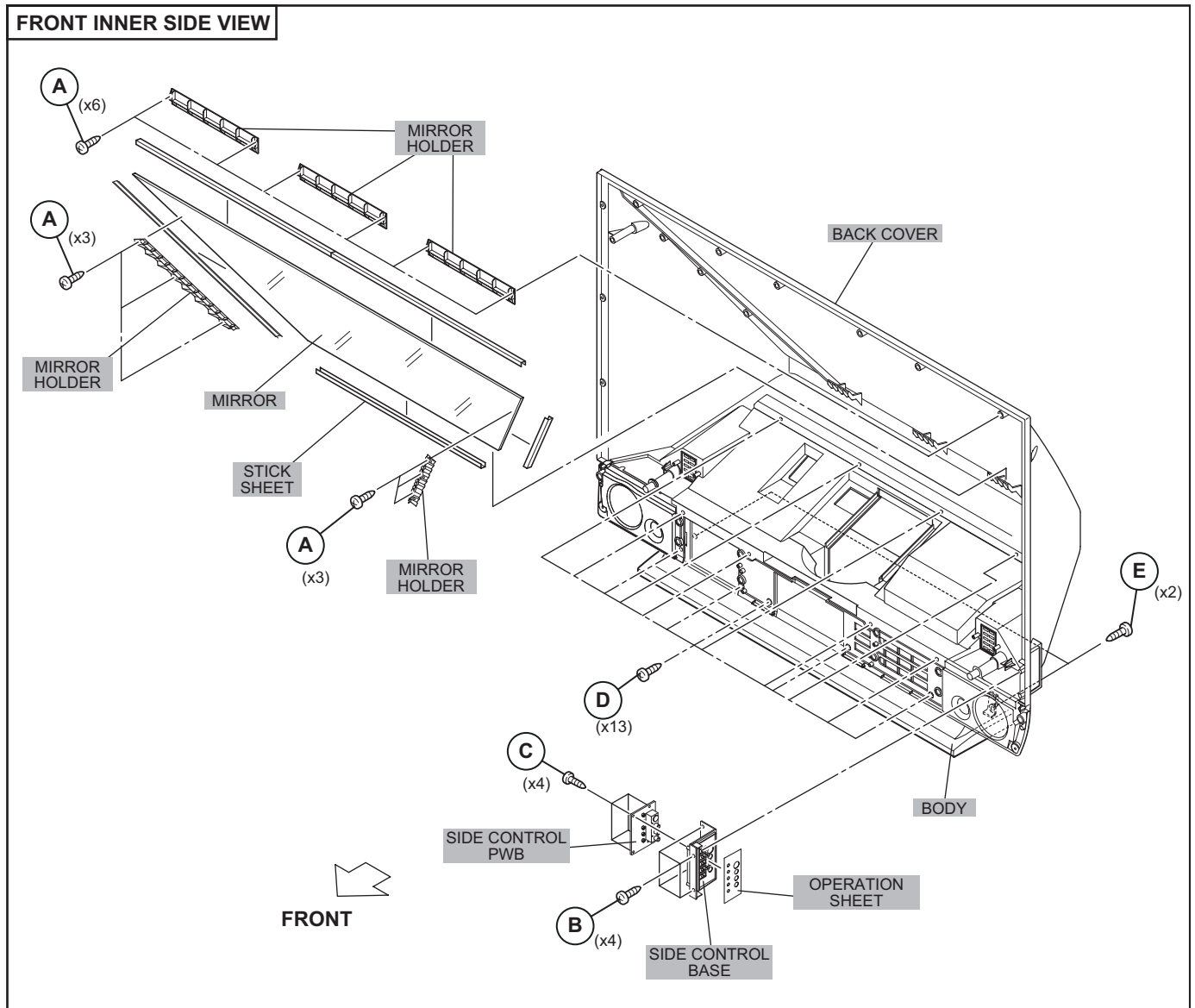

<BODY SIDE>

3.1.15 BODY COVER

- (1) Remove 9 screws [A] (BODY).
- (2) Remove 6 screws [B] (AV TERMINAL BOARD).
- (3) Take out the BODY COVER.

NOTE :

- Do not leave the BODY COVER removed for long time to prevent soiling from dust.

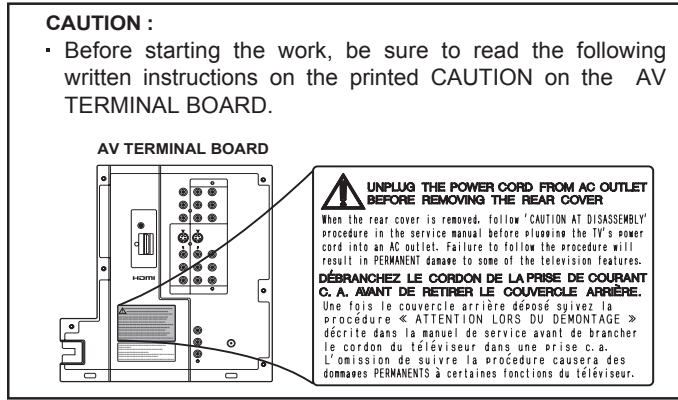

3.1.16 BODY BRACKET

- Take out the BODY COVER.
- (1) Remove 4 screws [C].
 - (2) Take out the BODY BRACKET.

3.1.17 MAIN UNIT

- Take out the BODY COVER.
 - Take out the BODY BRACKET.
- (1) Remove 2 screws [D].
 - (2) Take out the TOP SHADE BRACKET.

- (3) Take out the connector [FJ:12pin], [SW:4pin], [SPR:2pin (black)], [SPL:2pin(white)], [FL:7pin].
- (4) Remove 2 screws [E] from rear side.
- (5) Pull out the MAIN UNIT rear side.

CAUTION

- Except for confirmation of projection images on the screen and audio output through the speakers, the removed MAIN UNIT is still workable in the same state as if it is still built in the TV set. Therefore, the MAIN UNIT can be removed, if necessary, for board diagnosis, electric testing, etc. apart from confirmation of screen images and audio output.
- Do not leave the MAIN UNIT removed for long time to prevent soiling from dust.
- Because of the large size, at least 2 persons are recommended for removal and reassemble.
- When carrying the MAIN UNIT, use care not to drop, shock or shake it.
- Do not stain or damage the projection lens.
- Do not look directly at the light during service.
- Do not touch the lamp directly as it presents a burn hazard.

NOTE :

- When not performing repair work, attach the cap on the lens to preventing dust from covering.
- When mounting to the set, make sure the front of the lens is in contact with the cushion on the set (body) side.
- Make sure that FRONT LED PWB connector is completely connect to the RECEIVER PWB connector (CN10FL).
- When wire clamps are removed during work, use care to restore them precisely to their original positions. Performance can be affected if these are not returned to the original positions.

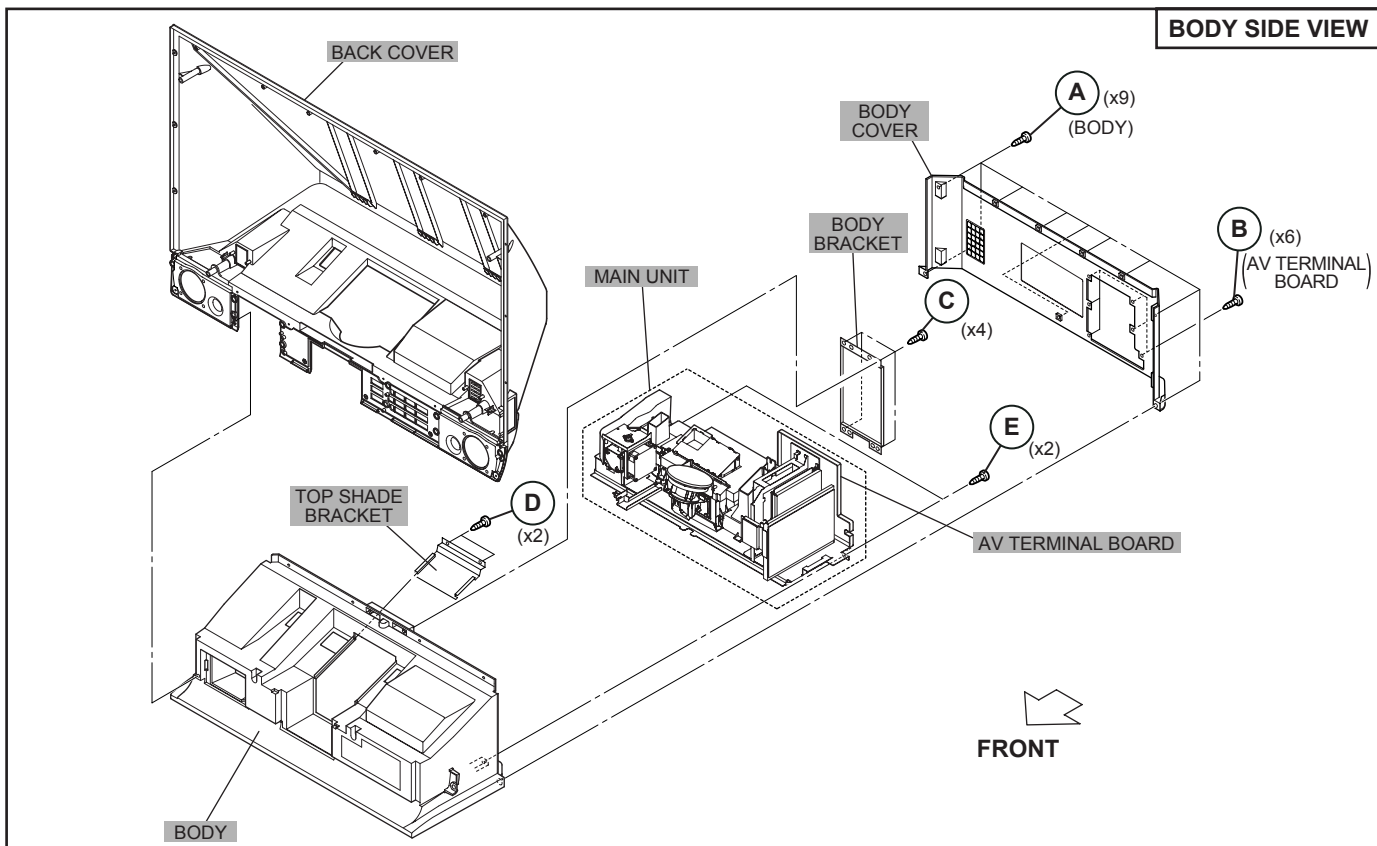

<INNER PWB SIDE>

3.1.18 AV TERMINAL BOARD

- Take out the BODY COVER.
 - (1) Remove 5 screws [**A**].
 - (2) Remove 1 screw [**B**].
 - (3) Pull out the POWER CORD CLAMP.
 - (4) Remove the nut [**C**] attaching the ANTENNA TERMINAL.
 - (5) Take out the AV TERMINAL BOARD.

3.1.19 SUB DRIVE PWB

- Take out the BODY COVER.
- Take out the BODY BRACKET.
- Take out the MAIN UNIT.
 - (1) Remove 4 screws [**D**].
 - (2) Take out the PWB HOLDER.
 - (3) Disconnect the connector [CN401] and [CN402].
 - (4) Remove 6 screws [**E**].
 - (5) Take out the SUB DRIVE PWB.

3.1.20 POWER PWB

- Take out the BODY COVER.
- Take out the BODY BRACKET.
- Take out the MAIN UNIT.
 - (1) Remove 1 screw [**F**].
 - (2) Take out the POWER PWB BRACKET.
 - (3) Disconnect the connector [CN90BL], [CN90SE], [CN90AA], [CN90B], [CN90DD] and [CN90G].
 - (4) Remove 5 screws [**G**].
 - (5) Take out the POWER PWB.

3.1.21 DIGITAL SIGNAL PWB

- Take out the BODY COVER.
- Take out the BODY BRACKET.
- Take out the MAIN UNIT.
- Take out the AV TERMINAL BOARD.
- Take out the PWB HOLDER
 - (1) Disconnect the connector [CN001], [CN002], [CN003], [CN0FC] and [CN0LV2].
 - (2) Remove 1 screw [**H**] attaching the earth wire.
 - (3) Remove 1 screw [**I**].
 - (4) Remove the both side SHIELD COVER.
 - (5) Take out the DIGITAL SIGNAL PWB.

CAUTION:

Make sure to perform the "SYSTEM SETTING" on page 1-10, when DIGITAL SIGNAL PWB is replaced.

3.1.22 RECEIVER PWB

- Take out the BODY COVER.
- Take out the BODY BRACKET.
- Take out the MAIN UNIT.
- Take out the AV TERMINAL BOARD.
- Take out the PWB HOLDER
 - (1) Remove 1 screw [**J**].
 - (2) Take out the ANALOG PWB BRACKET with PWB. (RECEIVER PWB/ANALOG SIGNAL PWB/REGULATOR PWB)
 - (3) Disconnect the connector [CN10FC], [CN10PH], [CN100R], [CN10PH], [CN100A], [CN100T], [CN100F], [CN10FJ], [CN10FL], [CN10SW], [CN10AA] and [CN10SP].
 - (4) Remove 4 screws [**K**].
 - (5) Take out the RECEIVER PWB.

3.1.23 ANALOG SIGNAL PWB

- Take out the BODY COVER.
- Take out the BODY BRACKET.
- Take out the MAIN UNIT.
- Take out the AV TERMINAL BOARD.
- Take out the PWB HOLDER
- Take out the RECEIVER PWB.
 - (1) Disconnect the connector [CN001], [CN002], [CN00D], [CN0J1], [CN0J2], [CN00T], [CN00F] and [CN00G].
 - (2) Remove 2 screws [**L**].
 - (3) Take out the ANALOG SIGNAL PWB.

3.1.24 REGULATOR PWB

- Take out the BODY COVER.
- Take out the BODY BRACKET.
- Take out the MAIN UNIT.
- Take out the AV TERMINAL BOARD.
- Take out the PWB HOLDER
- Take out the RECEIVER PWB.
 - (1) Disconnect the connector [CN20D], [CN203] and [CN20B].
 - (2) Remove 4 screws [**M**].
 - (3) Take out the REGULATOR PWB.

3.1.25 REAR JACK PWB

- Take out the BODY COVER.
- Take out the BODY BRACKET.
- Take out the MAIN UNIT.
- Take out the AV TERMINAL BOARD.
 - (1) Disconnect the connector [CNPH], [CNJ0J1] and [CNJ0J2].
 - (2) Remove 2 screws [**N**].
 - (3) Take out the REAR JACK PWB.

<OPTICAL SIDE>

3.1.26 LAMP FAN DUCT & THERMOSTAT

- Take out the BODY COVER.
- Take out the BODY BRACKET.
- Take out the MAIN UNIT.
 - (1) Remove 4 screws [**A**].
 - (2) Take out the LAMP FAN DUCT.
 - (3) Remove 2 screws [**B**].
 - (4) Take out the THERMOSTAT.

3.1.27 FAN CONTROL PWB

- Take out the BODY COVER.
- Take out the BODY BRACKET.
- Take out the MAIN UNIT.
 - (1) Disconnect the connector [CN801:7pin (MAIN DRIVE PWB)], [CN802:3pin (OPTICAL BLOCK COOLING FAN)], [CN803:3pin (LAMP COOLING FAN)] and [CN804:4pin (LAMP BALLAST UNIT)].
 - (2) Remove 1 screw [**C**].
 - (3) Take out the FAN CONTROL PWB.

3.1.28 REMOTE SENSOR PWB

- Take out the BODY COVER.
- Take out the BODY BRACKET.
- Take out the MAIN UNIT.
 - (1) Remove 1 screw [**D**].
 - (2) Take out the REMOTE SENSOR PWB.

3.1.29 OPTICAL / DRIVE ASS'Y

- Take out the BODY COVER.
- Take out the BODY BRACKET.
- Take out the MAIN UNIT.
 - (1) Remove 2 screws [**E**].
 - (2) Take out the SHADE COVER.
 - (3) Remove 2 screws [**F**].
 - (4) Take out the FRONT SHADE BRACKET.
 - (5) Remove 7 screws [**G**].
 - (6) Slightly raise and take out the OPTICAL / DRIVE ASS'Y.
 - (7) Peel off the shield (copper film) tapes.

NOTE :

- The OPTICAL / DRIVE ASS'Y contains precision optical components.
Handle carefully and avoid imparting strong shock.
- OPTICAL / DRIVE ASS'Y construction
 - 1) Optical block :
(D-ILA device, PBS, Field lens, Integrater, Mirror etc.)
 - 2) Projection lens
 - 3) Optical base
 - 4) MAIN DRIVE PWB ASS'Y
 - 5) Top duct
 - 6) Shield tape
- When not performing repair work, attach the cap on the lens to preventing dust from covering.
- When mounting to the set, make sure the front of the lens side is in contact with the cushion on the body side.
- When installing this kit (OPTICAL/DRIVE ASS'Y) to the set, first mount the FRONT SHADE BRACKET and SHADE COVER (with cushion) to the kit (lens section).
- Do not leave the OPTICAL / DRIVE ASS'Y removed for long time to prevent soiling from dust.

3.1.30 MAIN DRIVE PWB

- Take out the BODY COVER.
- Take out the BODY BRACKET.
- Take out the MAIN UNIT.
 - (1) Take out the TOP DUCT PLATE.
 - (2) Remove 2 screws [**H**].
 - (3) Take out the TOP DUCT.
 - (4) Take out the SHIELD TOP CASE.
 - (5) Remove 4 screws [**I**].
 - (6) Take out the MAIN DRIVE PWB.
 - (7) Take out the SHIELD PLATE.
 - (8) Slightly raise and take out the OPTICAL BLOCK.

3.1.31 OPTICAL BLOCK COOLING FAN

- Take out the BODY COVER.
- Take out the BODY BRACKET.
- Take out the MAIN UNIT.
 - (1) Remove 3 screws [**J**].
 - (2) Take out the SIROCCO TOP CASE.
 - (3) Remove 3 screws [**K**].
 - (4) Take out the OPTICAL BLOCK COOLING FAN.

3.1.32 LAMP COOLING FAN

- Take out the BODY COVER.
- Take out the BODY BRACKET.
- Take out the MAIN UNIT.
 - (1) Remove 2 screws [**L**].
 - (2) Take out the LAMP FAN BRACKET ASSY.
 - (3) Remove 4 screws [**M**].
 - (4) Take out the LAMP COOLING FAN.

3.1.33 LAMP BALLAST UNIT COOLING FAN

- Take out the BODY COVER.
- Take out the BODY BRACKET.
- Take out the MAIN UNIT.
 - (1) Remove 3 screws [**N**].
 - (2) Remove 4 screws [**O**].
 - (3) Take out the COOLING FAN (LAMP BALLAST UNIT).

3.1.34 LAMP BALLAST UNIT

- Take out the BODY COVER.
- Take out the BODY BRACKET.
- Take out the MAIN UNIT.
- Take out the LAMP BALLAST UNIT COOLING FAN.
 - (1) Take out the wire of LAMP BALLAST UNIT.
 - (2) Remove 4 screws [**P**].
 - (3) Take out the BALLAST BRACKET BOTTOM.
 - (4) Remove 4 screws [**Q**].
 - (5) Take out the BALLAST COVER.
 - (6) Take out the LAMP BALLAST UNIT.

3.1.35 LAMP COVER SW PWB

- Take out the BODY COVER.
- Take out the BODY BRACKET.
- Take out the MAIN UNIT.
 - (1) Remove 1 screw [**R**].
 - (2) Take out the LAMP COVER SW PWB.

3.1.36 SHIELD PLATE ATTACHMENT PROCESS

- Take out the TOP DUCT / TOP DUCT PLATE.
- Take out the MAIN DRIVE PWB with SHIELD TOP CASE.

< Assembly >

- (1) Copper film case with laminate surface to be top.
- (2) Fold 9 points (①~⑨) as shown in [A] an arrow view Fig.1.
- (3) Attach the double-faced tapes [B] as shown in Fig.1.
- (4) Stick the tape [C] as shown in Fig.1.
- (5) Make copper film case to be SHIELD PLATE (box-shape).

< Attachment >

- (6) Install the SHIELD PLATE (box-shape).
- (7) Install the MAIN DRIVE PWB.
- (8) Install 4 screws [D] to MAIN DRIVE PWB.
- (9) Install the SHIELD TOP CASE .
- (10) Attach the shield (copper film) tapes 6 positions [E] and [F] as shown in Fig.2 and Fig.5.
- (11) Install the TOP DUCT.
- (12) Install 2 screws [G] as shown in Fig.5.
- (13) Install the TOP DUCT PLATE as shown in Fig.5.
- (14) Attach the shield (copper film) tapes 4 positions [H] and [I] as shown in Fig.3 and Fig.5.
- (15) Then attach the shield (copper film) tapes 11 positions [J], [K], [L], and [M] as shown in Fig.4 and Fig.5.

<ASSEMBLY PROCESS>

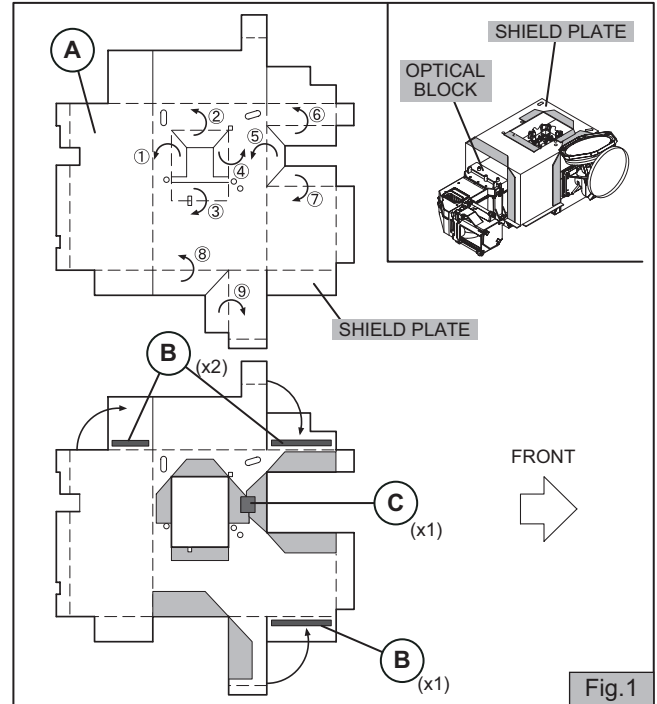

Fig.1

<ASSEMBLY and ATTACHMENT PROCESS>

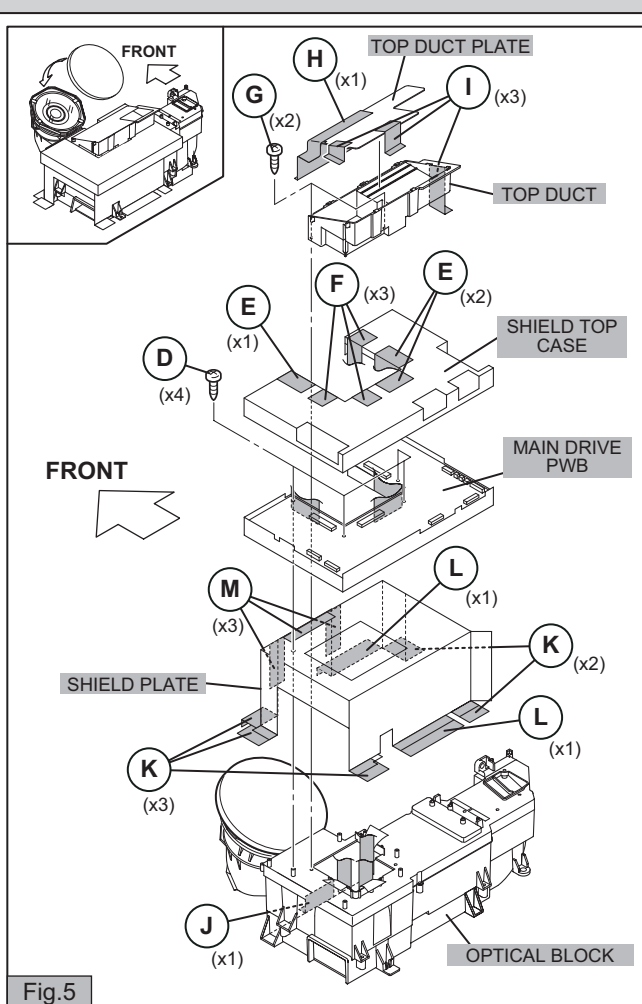

Fig.5

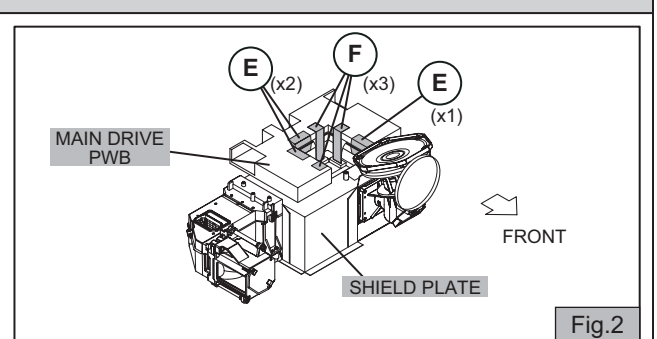

Fig.2

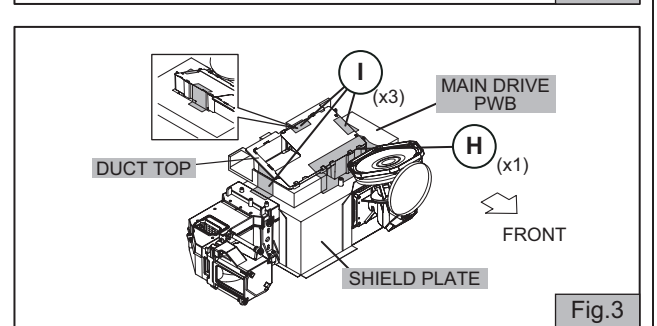

Fig.3

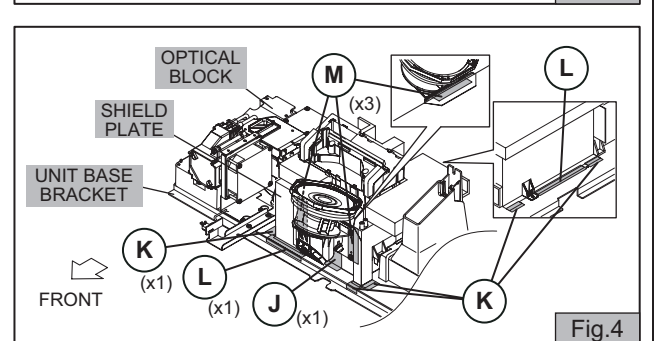

Fig.4

3.2 MEMORY IC REPLACEMENT

3.2.1 MEMORY IC

This memory IC stores data for proper operation of the video and Drive circuits.
When replacing, be sure to use an IC containing this (initial value) data.

3.2.2 MEMORY IC REPLACEMENT PROCEDURE

1. Power off

Switch off the power and disconnect the power cord from the wall outlet.

2. Replace the memory IC

Initial value must be entered into the new IC.

3. Power on

Connect the power cord to the wall outlet and switch on the power.

4. SERVICE MENU setting

Before entering the SERVICE MENU, confirm that the setting of TV/CATV SW of the REMOTE CONTROL UNIT is at the "TV" side and the setting of VCR/DVD SW of the REMOTE CONTROL UNIT is at the "VCR" side. If the switches have not been properly set, you cannot enter the SERVICE MENU.

- 1) Press **[SLEEP TIMER]** key and while the indication of SLEEP TIMER 0 MIN is being displayed, press **[DISPLAY]** key and **[VIDEO STATUS]** key (Fig.2) simultaneously.
- 2) The SERVICE MENU screen of Fig.1 is displayed.
- 3) Verify what to set in the SERVICE MENU, and set whatever is necessary (Fig.1).
Refer to the SERVICE ADJUSTMENT for setting.
- 4) Press the **[BACK]** key to return the SERVICE MENU.

5. Receive channel setting

Refer to the OPERATING INSTRUCTIONS (USER'S GUIDE) and set the receive channels (Channels Preset) as described.

6. User settings

Check the user setting items according to after page. Where these do not agree, refer to the OPERATING INSTRUCTIONS (USER'S GUIDE) and set the items as described.

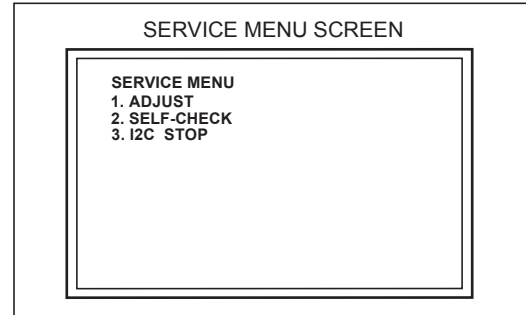

Fig.1

3.2.3 SERVICE MENU SETTING ITEMS

Setting item	Item No.	Remark
1.ADJUST		
VIDEO SYSTEM	S001~S039	Adjust
AUDIO SYSTEM	T001~T010	
PANEL CONTROL SYSTEM	P001~P010	Do not adjust (Fixed value)
DRIVE SYSTEM	D001~D187	
SYSTEM SETTING	Z001~Z010	

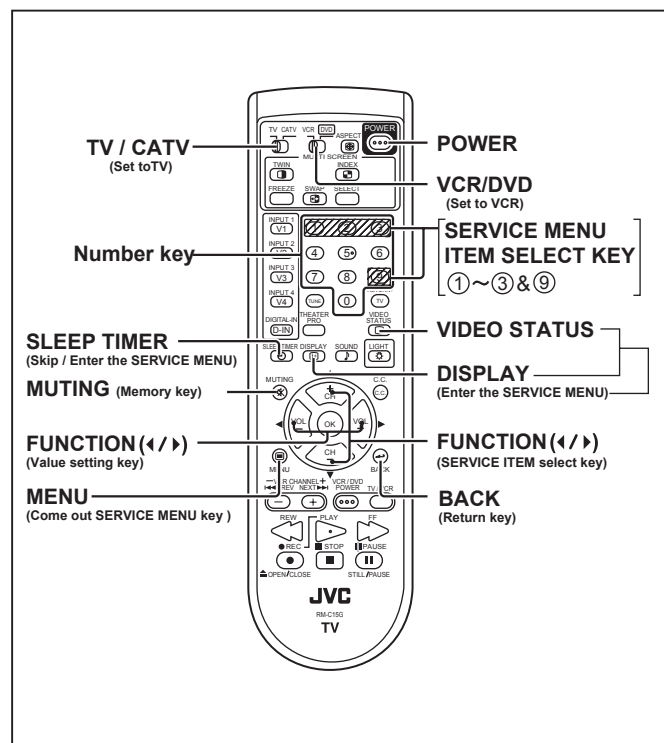

Fig.2

3.2.4 SETTING OF FACTORY SHIPMENT

3.2.4.1 BUTTON OPERATION

Setting item	Setting position
POWER	OFF
INPUT	TV
CHANNEL	CABLE-02
VOLUME	10

3.2.4.2 REMOTE CONTROL DIRECT OPERATION

Setting item	Setting position	
INPUT	TV	
CHANNEL	CABLE-02	
VOLUME	10	
MUTING	OFF	
DISPLAY	OFF	
SOUND	A.H.S	OFF
	BBE	ON
	SMART SOUND	OFF [HD-52Z585 / HD-61Z585]
ASPECT	REGULAR	
CLOSED CAPTION (C.C)	OFF	
VIDEO STATUS	DYNAMIC	
TWIN PICTURE SOURCE	LEFT SIDE : CA02 RIGHT SIDE : INPUT1	

3.2.4.3 REMOTE CONTROL MENU OPERATION

(1) PICTURE ADJUST[1]

Setting item		STANDARD	DYNAMIC	THEATER	GAME
TINT	NTSC / 525i / 525p	00	00	00	00
	1125i / 750p	00	00	00	00
COLOR	NTSC / 525i / 525p	00	00	00	00
	1125i / 750p	00	00	00	00
PICTURE	NTSC / 525i / 525p	00	+10	00	-10
	1125i / 750p	00	+10	00	-10
BRIGHT	NTSC / 525i / 525p	00	00	00	00
	1125i / 750p	00	00	00	00
DETAIL	NTSC / 525i / 525p	00	+05	00	00
	1125i / 750p	00	+05	00	00
COLOR TEMPERATURE	NTSC / 525i / 525p	LOW	HIGHT	HIGHT	HIGHT
	1125i / 750p	LOW	HIGHT	LOW	HIGHT

(2) PICTURE ADJUST [2]

Setting item	Setting position
DIG. NOISE CLEAR	OFF
NATURAL CINEMA	AUTO
COLOR MANAGEMENT	ON
DYNAMIC GAMMA	ON

(3) SOUND ADJUST

Setting item	Setting position
TREBLE	00
BASS	00
BALANCE	00
MTS	STEREO

(4) CLOCK / TIMERS

Setting item	Setting position
SET CLOCK	(Unnecessary to set)
ON / OFF TIMER	NO

(5) INITIAL SETUP

Setting item	Setting position	Setting item	Setting position
CENTER CH INPUT	OFF	POWER INDICATOR	HIGH
DIGITAL-IN	SIZE-1 (at 480p signal input)	LANGUAGE	ENG
DIGITAL-IN AUDIO	DIGITAL	CLOSED CAPTION	OFF (CAPTION-CC1-T1)
TV SPEAKER	ON	AUTO SHUT OFF	OFF
AUDIO OUT	FIX	XDS ID	ON
NOISE MUTING	ON	AUTO TUNER SET UP	Unnecessary to set
FRONT PANEL LOCK	OFF	CHANNEL SUMMARY	---- (Unnecessary to set)
V1 SMART INPUT	OFF	V-CHIP	OFF
VIDEO INPUT LABEL	--- (Blank)	SET LOCK CODE	(0000) (Unnecessary to set)
POSITION ADJUSTMENT	Center	AUTO DEMO	OFF

3.3 REPLACEMENT OF CHIP COMPONENT

3.3.1 CAUTIONS

- (1) Avoid heating for more than 3 seconds.
- (2) Do not rub the electrodes and the resist parts of the pattern.
- (3) When removing a chip part, melt the solder adequately.
- (4) Do not reuse a chip part after removing it.

3.3.2 SOLDERING IRON

- (1) Use a high insulation soldering iron with a thin pointed end of it.
- (2) A 30w soldering iron is recommended for easily removing parts.

3.3.3 REPLACEMENT STEPS

1. How to remove Chip parts [Resistors, capacitors, etc.]

- (1) As shown in the figure, push the part with tweezers and alternately melt the solder at each end.

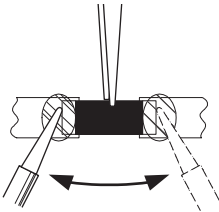

- (2) Shift with the tweezers and remove the chip part.

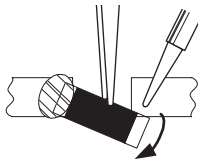

[Transistors, diodes, variable resistors, etc.]

- (1) Apply extra solder to each lead.



- (2) As shown in the figure, push the part with tweezers and alternately melt the solder at each lead. Shift and remove the chip part.

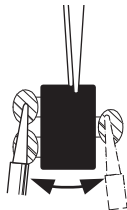

Note :

After removing the part, remove remaining solder from the pattern.

2. How to install Chip parts [Resistors, capacitors, etc.]

- (1) Apply solder to the pattern as indicated in the figure.

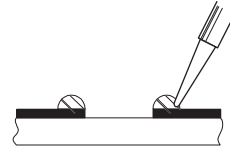

- (2) Grasp the chip part with tweezers and place it on the solder. Then heat and melt the solder at both ends of the chip part.

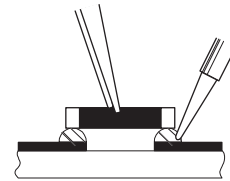

[Transistors, diodes, variable resistors, etc.]

- (1) Apply solder to the pattern as indicated in the figure.
- (2) Grasp the chip part with tweezers and place it on the solder.
- (3) First solder lead **A** as indicated in the figure.

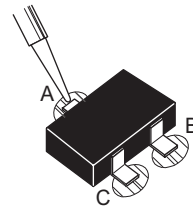

- (4) Then solder leads **B** and **C**.

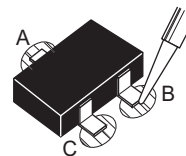

SECTION 4 ADJUSTMENTS

4.1 ADJUSTMENT PREPARATION

- (1) You can make the necessary adjustments for this unit with either the remote control unit or with the adjustment equipment and parts as given below.
- (2) Adjustment with the remote control unit is made on the basis of the initial setting values, however, the new setting values which set the screen to its optimum condition may differ from the initial settings.
- (3) Make sure that AC power is turned on correctly.
- (4) Turn on the power for the set and test equipment before use, and start the adjustment procedures after waiting at least 30 minutes.
- (5) Unless otherwise specified, prepare the most suitable reception or input signal for adjustment.
- (6) Never touch any adjustment parts, which are not specified in the list for this variable resistors, transformers, trimmer capacitors, etc.

4.2 PRESETTING BEFORE ADJUSTMENT

Unless otherwise specified in the adjustment instructions, preset the following functions with the remote control unit.

Setting item	Settings position
VIDEO STATUS	STANDARD
PICTURE (TINT / COLOR / BRIGHT/PICTURE / DETAIL)	All 00
COLOR TEMPERATURE	LOW
DIG. NOISE CLEAR	OFF
COLOR MANAGEMENT	ON
DYNAMIC GAMMA	ON
SOUND (BASS / TREBLE / BALANCE)	All 00
MTS	STEREO
BBE	OFF
A.H.S	OFF
SMART SOUND	OFF [HD-52Z585 / HD-61Z585]
ASPECT	FULL

4.3 MEASURING INSTRUMENT AND FIXTURES

- 1) DC voltmeter (or Digital voltmeter)
- 2) Oscilloscope
- 3) Signal generator (Pattern generator)
[NTSC / 525i / 750p / 1125i / DIGITAL]
- 4) TV audio multiplex signal generator
- 5) Remote control unit

4.4 ADJUSTMENT ITEMS

■ OPTICAL BLOCK / DRIVE CIRCUIT

- LENS FOCUS adjustment
- DRIVE CONVERGENCE adjustment
- DRIVE CENTER POSITION adjustment

■ VIDEO CIRCUIT

- 525i A-D OFFSET adjustment
- 1125i BRIGHTNESS adjustment
- 1125i A-D OFFSET adjustment
- SUB SCREEN A-D OFFSET adjustment
- WHITE BALANCE (HIGHT LIGHT)

■ MTS CIRCUIT

- MTS INPUT LEVEL adjustment
- MTS SEPARATION adjustment

4.5 BASIC OPERATION OF THE SERVICE MENU

Operate the SERVICE MENU with the remote control unit.

4.5.1 HOW TO ENTER THE SERVICE MENU

- (1) Press the [SLEEP TIMER] key and while indication of "SLEEP TIMER 0 MIN." is being displayed, press [DISPLAY] key and [VIDEO STATUS] key simultaneously, and the SERVICE MENU screen of Fig.1 will be displayed.

4.5.2 SELECT THE SERVICE MENU ITEM

- (1) When the SERVICE MENU is displayed, press any key of the [1] / [2] / [3] / [9] keys to enter the corresponding menu mode.

4.5.3 SELECT THE SETTING ITEM & SETTING VALUE

- (1) Select the service item using the [FUNCTION (▲ / ▼)] key.
- (2) Set the value using the [FUNCTION (◀ / ▶)] key.

4.5.4 SETTING OF THE OPTICAL BLOCK / DRIVE CIRCUIT

- (1) R/B mode (DRIVE / CONVERGENCE) adjust
Set the R mode value using the [FUNCTION (▲ / ▼)] key
Set the B mode value using the [FUNCTION (◀ / ▶)] key
- (2) RGB BOX mode (DRIVE CENTER POSITION) adjust
Set the horizontal center position value using the [FUNCTION (▲ / ▼)] key
Set the vertical center position value using the [FUNCTION (◀ / ▶)] key

4.5.5 MEMORIZED SETTING VALUE

- (1) Press the [MUTING] key to memorize the adjustment value. If not to do it, adjustment data is not memorized to the memory IC. And if exit the adjustment mode before memorize the data, the adjustment which your changed value is canceled.
- (2) Adjustment data is applied at once in OPTICAL BLOCK / DRIVE CIRCUIT adjustment mode.

CAUTION

- Individual items 1, 2 and 3 on the SERVICE MENU screen (Fig.1) are selected by the Number key (Fig.2).
- When selecting each item on the SERVICE MENU, if [4] ~ [8] keys other than [1], [2], [3] and [9] keys are pressed by mistake, another screen that is not the SERVICE MENU will appear. In such a case, press the [BACK] key immediately and return to the SERVICE MENU screen.
- Do not press the [MUTING] key.

4.5.6 HOW TO EXIT THE SERVICE MENU

Press the [MENU] key to exit the SERVICE MENU.

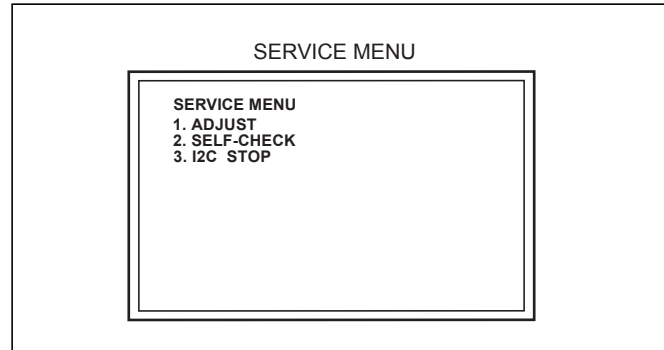

Fig.1

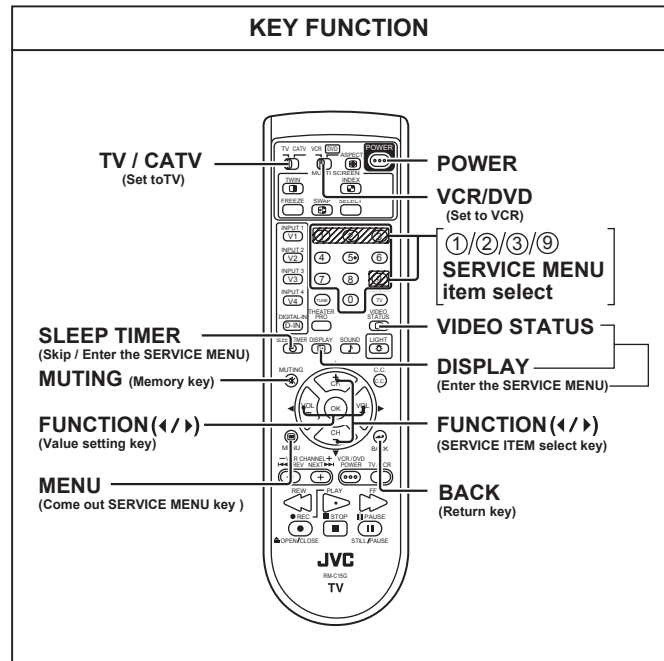

Fig.2

4.5.7 DESCRIPTION OF STATUS DISPLAY

The status display on the upper part of the SERVICE MENU screen is common.

(1) SIGNAL SYSTEM

(OSD)	(EXPLAIN)
NTSC3	: NTSC3.58
NTSC4	: NTSC4.48
525I	: 525i
525P	: 525p
750P	: 750p
1125I6	: 1125i 60Hz
RGB5	: RGB 525i
D525I	: digital 525i
D525P	: digital 525p
D1256I6	: digital 1125i 60Hz
H525I	: HDMI 525i
H525P	: HDMI 525p
H750P	: HDMI 750p
H1125I6	: HDMI 1125i 60Hz

(2) ASPECT

SINGLE

1409	: FULL
1609	: PANORAMA
1609S	: CINEMA
FULL	: REGULAR

TWIN / INDEX

FRZ	: TWIN
STD	: INDEX (12CH)

(3) VIDEO STATUS

STD	: STANDARD
DYN	: DYNAMIC
TH	: THEATER
GAME	: GAME

(4) WHITE BALANCE

H	: HIGH
M	: LOW

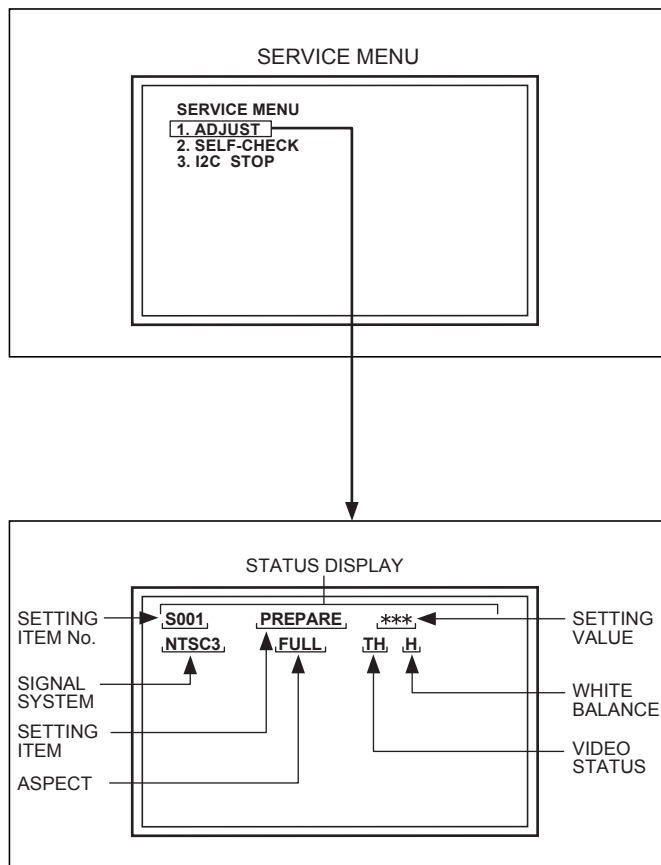

[1. ADJUST] MENU

4.5.8 SETTING OF THE SERVICE MENUS

4.5.8.1 [1.ADJUST]

■ Do not change settings of items that are not included in the "ADJUSTMENT PROCEDURE".

- [Function (◀ / ▶)] key
For scrolling up/down the setting items.



- [SLEEP TIMER] key
For switching to the next items.



- [Function (▲ / ▼)] key
For scrolling up/down the setting values.

4.5.8.2 [2.SELF CHECK]

Refer to "SECTION 5 TROUBLESHOOTING"

4.5.8.3 [3.I²C STOP]

Setting for this item is not required in servicing

4.5.8.4 [9] RGB BOX PATTERN

Adjustment of DRIVE CIRCUIT (CONVERGENCE / CENTER POSITION)

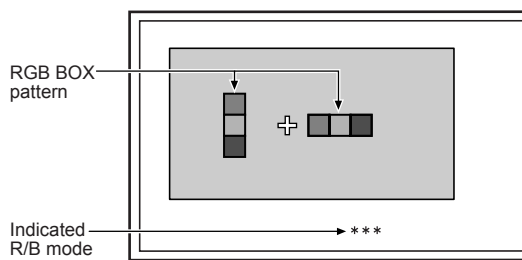

[9] RGB BOX PATTERN

4.6 INITIAL SETTING VALUE OF SERVICE MENU

- (1) Adjustment of the SERVICE MENU is made on the basis of the initial setting values; however, the new setting values which set the screen in its optimum condition may differ from the initial setting.
- (2) Do not change the initial setting values of the setting items NOT LISTED IN ADJUSTMENT.

CAUTION:

Never change the initial setting value any adjustments **except** for those that are designated in the adjustment procedures. In case where you have made undesignated adjustments by mistake, never press the [MUTING] key on the remote control unit. Whenever you had not pressed the [MUTING] key, you would be able to recover the initial value by switching the [POWER] key.

4.6.1 [1.ADJUST]

VIDEO SYSTEM

Item No.	Item name	Variable range	Setting value
S001	PREPARE	0~31	0
S002	NTSC BL	0~15	1
S003	NTSC CNT	0~255	44
S004	NT CR OF	0~15	4
S005	NT CB OF	0~15	4
S006	525i BL	0~15	1
S007	525i CNT	0~255	44
S008	5i CB OF	0~15	0
S009	5i CR OF	0~15	0
S010	5i CR GN	0~15	4
S011	5i CB GN	0~15	4
S012	HD BL	0~63	0
S013	HD CB OF	0~63	0
S014	HD CR OF	0~63	0
S015	RT CONT	0~15	7
S016	RT CB OF	0~15	2
S017	RT CR OF	0~15	5
S018	RT CL GA	0~15	4
S019	PC CL MB	0~7	0
S020	PC CL LB	0~255	0
S021	PC CL MR	0~3	0
S022	PC CL LR	0~255	0
S023	(NO DISPLAY)	0~255	0
S024	(NO DISPLAY)	0~255	0
S025	(NO DISPLAY)	0~255	0
S026	(NO DISPLAY)	0~255	0
S027	(NO DISPLAY)	0~255	0
S028	(NO DISPLAY)	0~255	0
S029	(NO DISPLAY)	0~255	0
S030	R DRIVE	0~255	0
S031	G DRIVE	0~255	0
S032	B DRIVE	0~255	0
S033	(NO DISPLAY)	0~255	0
S034	(NO DISPLAY)	0~255	0
S035	(NO DISPLAY)	0~255	0
S036	(NO DISPLAY)	0~255	0
S037	(NO DISPLAY)	0~255	0
S038	(NO DISPLAY)	0~255	0
S039	ILA COM	0~255	0

AUDIO SYSTEM

Item No.	Item name	Variable range	Setting value
T001	IN LEVEL	0~255	007
T002	LOW SEP	0~255	037
T003	HIGH SEP	0~255	033
T004	AFC	0~255	0 (Fixed)
T005	(NO DISPLAY)	0~255	0 (Fixed)
T006	ATT V ON	0~1	0 (Fixed)
T007	ATT U ON	0~1	0 (Fixed)
T008	ATT C ON	0~1	0 (Fixed)
T009	(NO DISPLAY)	0~255	0 (Fixed)
T010	(NO DISPLAY)	0~255	0 (Fixed)

PANEL CONTROL SYSTEM [Do not adjust : All fixed]

Item No.	Item name	Variable range	Setting value
P001	TM HOR H	0~255	0
P002	TM HOR L	0~255	0
P003	TM MIN	0~255	0
P004	TEMP	0~255	0
P005	(NO DISPLAY)	0~255	0
P006	(NO DISPLAY)	0~255	0
P007	(NO DISPLAY)	0~255	0
P008	(NO DISPLAY)	0~255	0
P009	(NO DISPLAY)	0~255	0
P010	(NO DISPLAY)	0~255	0

DRIVE SYSTEM [Do not adjust : All fixed]

Item No.	Item name	Variable range	Setting value
D001	SLV GN	0~3F	00
D002	SLVH GN	0~3F	00
D003	SLH GN	0~3F	00
D004	SLV Pf	0~03	00
D005	SLH Pf H	0~01	00
D006	SLH Pf L	0~03	00
D007	SL EGCON	0~3F	00
D008	SL EGONF	0~01	00
D009	SL CRGON	0~3F	00
D010	SL CRGON	0~01	00
D011	SL ON OF	0~01	00

Item No.	Item name	Variable range	Setting value
D012	SV GN	0~3F	00
D013	SVH GN	0~3F	00
D014	SH GN	0~3F	00
D015	SV Pf	0~03	00
D016	SV Pf H	0~01	00
D017	SV Pf L	0~03	00
D018	SYL CON	0~3F	00
D019	SYL CONF	0~01	00
D020	SYH CON	0~3F	00
D021	SYH CONF	0~01	00
D022	SC CON	0~3F	00
D023	SC CNONF	0~01	00
D024	SPM BLC	0~3F	00
D025	SPM BLCO	0~01	00
D026	SLIM	0~3F	00
D027	SLIMONF	0~01	00
D028	SCRG	0~3F	00
D029	SRGONF	0~01	00
D030	S ONF	0~01	00
D031	pb GN	0~3F	00
D032	pb Pf H	0~01	00
D033	pb Pf L	0~03	00
D034	pb CRG	0~3F	00
D035	pb CRGON	0~01	00
D036	pb ONF	0~01	00
D037	pr GN	0~3F	00
D038	pr Pf H	0~01	00
D039	pr Pf L	0~03	00
D040	pr CRG	0~3F	00
D041	pr CRGON	0~01	00
D042	pr ONF	0~01	00
D043	ENH ONF	0~01	00
D044	(NO DISPLAY)	0~FF	00
D045	(NO DISPLAY)	0~FF	00
D046	(NO DISPLAY)	0~FF	00
D047	(NO DISPLAY)	0~FF	00
D048	(NO DISPLAY)	0~FF	00
D049	(NO DISPLAY)	0~FF	00
D050	(NO DISPLAY)	0~FF	00
D051	(NO DISPLAY)	0~FF	00
D052	(NO DISPLAY)	0~FF	00
D053	(NO DISPLAY)	0~FF	00
D054	(NO DISPLAY)	0~FF	00
D055	(NO DISPLAY)	0~FF	00
D056	(NO DISPLAY)	0~FF	00
D057	(NO DISPLAY)	0~FF	00
D058	(NO DISPLAY)	0~FF	00
D059	(NO DISPLAY)	0~FF	00

Item No.	Item name	Variable range	Setting value
D060	(NO DISPLAY)	0~FF	00
D061	(NO DISPLAY)	0~FF	00
D062	(NO DISPLAY)	0~FF	00
D063	(NO DISPLAY)	0~FF	00
D064	(NO DISPLAY)	0~FF	00
D065	(NO DISPLAY)	0~FF	00
D066	(NO DISPLAY)	0~FF	00
D067	(NO DISPLAY)	0~FF	00
D068	(NO DISPLAY)	0~FF	00
D069	(NO DISPLAY)	0~FF	00
D070	(NO DISPLAY)	0~FF	00
D071	(NO DISPLAY)	0~FF	00
D072	(NO DISPLAY)	0~FF	00
D073	(NO DISPLAY)	0~FF	00
D074	(NO DISPLAY)	0~FF	00
D075	(NO DISPLAY)	0~FF	00
D076	(NO DISPLAY)	0~FF	00
D077	(NO DISPLAY)	0~FF	00
D078	(NO DISPLAY)	0~FF	00
D079	(NO DISPLAY)	0~FF	00
D080	(NO DISPLAY)	0~FF	00
D081	(NO DISPLAY)	0~FF	00
D082	(NO DISPLAY)	0~FF	00
D083	(NO DISPLAY)	0~FF	00
D084	(NO DISPLAY)	0~FF	00
D085	(NO DISPLAY)	0~FF	00
D086	(NO DISPLAY)	0~FF	00
D087	(NO DISPLAY)	0~FF	00
D088	(NO DISPLAY)	0~FF	00
D089	(NO DISPLAY)	0~FF	00
D090	(NO DISPLAY)	0~FF	00
D091	(NO DISPLAY)	0~FF	00
D092	(NO DISPLAY)	0~FF	00
D093	(NO DISPLAY)	0~FF	00
D094	(NO DISPLAY)	0~FF	00
D095	(NO DISPLAY)	0~FF	00
D096	(NO DISPLAY)	0~FF	00
D097	(NO DISPLAY)	0~FF	00
D098	(NO DISPLAY)	0~FF	00
D099	(NO DISPLAY)	0~FF	00
D100	(NO DISPLAY)	0~FF	00
D101	(NO DISPLAY)	0~FF	00
D102	(NO DISPLAY)	0~FF	00
D103	(NO DISPLAY)	0~FF	00
D104	(NO DISPLAY)	0~FF	00
D105	(NO DISPLAY)	0~FF	00
D106	(NO DISPLAY)	0~FF	00
D107	(NO DISPLAY)	0~FF	00

Item No.	Item name	Variable range	Setting value
D108	(NO DISPLAY)	0~FF	00
D109	(NO DISPLAY)	0~FF	00
D110	(NO DISPLAY)	0~FF	00
D111	(NO DISPLAY)	0~FF	00
D112	(NO DISPLAY)	0~FF	00
D113	(NO DISPLAY)	0~FF	00
D114	(NO DISPLAY)	0~FF	00
D115	(NO DISPLAY)	0~FF	00
D116	(NO DISPLAY)	0~FF	00
D117	(NO DISPLAY)	0~FF	00
D118	(NO DISPLAY)	0~FF	00
D119	(NO DISPLAY)	0~FF	00
D120	(NO DISPLAY)	0~FF	00
D121	(NO DISPLAY)	0~FF	00
D122	(NO DISPLAY)	0~FF	00
D123	(NO DISPLAY)	0~FF	00
D124	(NO DISPLAY)	0~FF	00
D125	(NO DISPLAY)	0~FF	00
D126	(NO DISPLAY)	0~FF	00
D127	(NO DISPLAY)	0~FF	00
D128	(NO DISPLAY)	0~FF	00
D129	(NO DISPLAY)	0~FF	00
D130	(NO DISPLAY)	0~FF	00
D131	(NO DISPLAY)	0~FF	00
D132	(NO DISPLAY)	0~FF	00
D133	(NO DISPLAY)	0~FF	00
D134	(NO DISPLAY)	0~FF	00
D135	(NO DISPLAY)	0~FF	00
D136	(NO DISPLAY)	0~FF	00
D137	(NO DISPLAY)	0~FF	00
D138	(NO DISPLAY)	0~FF	00
D139	(NO DISPLAY)	0~FF	00
D140	(NO DISPLAY)	0~FF	00
D141	(NO DISPLAY)	0~FF	00
D142	(NO DISPLAY)	0~FF	00
D143	(NO DISPLAY)	0~FF	00
D144	(NO DISPLAY)	0~FF	00
D145	(NO DISPLAY)	0~FF	00
D146	(NO DISPLAY)	0~FF	00
D147	(NO DISPLAY)	0~FF	00
D148	(NO DISPLAY)	0~FF	00
D149	(NO DISPLAY)	0~FF	00
D150	(NO DISPLAY)	0~FF	00
D151	(NO DISPLAY)	0~FF	00
D152	(NO DISPLAY)	0~FF	00
D153	ENH ONF	0~FF	00
D154	(NO DISPLAY)	0~FF	00

Item No.	Item name	Variable range	Setting value
D155	(NO DISPLAY)	0~FF	00
D156	(NO DISPLAY)	0~FF	00
D157	(NO DISPLAY)	0~FF	00
D158	(NO DISPLAY)	0~FF	00
D159	(NO DISPLAY)	0~FF	00
D160	(NO DISPLAY)	0~FF	00
D161	(NO DISPLAY)	0~FF	00
D162	(NO DISPLAY)	0~FF	00
D163	(NO DISPLAY)	0~FF	00
D164	(NO DISPLAY)	0~FF	00
D165	(NO DISPLAY)	0~FF	00
D166	(NO DISPLAY)	0~FF	00
D167	(NO DISPLAY)	0~FF	00
D168	(NO DISPLAY)	0~FF	00
D169	(NO DISPLAY)	0~FF	00
D170	(NO DISPLAY)	0~FF	00
D171	(NO DISPLAY)	0~FF	00
D172	(NO DISPLAY)	0~FF	00
D173	(NO DISPLAY)	0~FF	00
D174	(NO DISPLAY)	0~FF	00
D175	(NO DISPLAY)	0~FF	00
D176	(NO DISPLAY)	0~FF	00
D177	(NO DISPLAY)	0~FF	00
D178	(NO DISPLAY)	0~FF	00
D179	(NO DISPLAY)	0~FF	00
D180	(NO DISPLAY)	0~FF	00
D181	(NO DISPLAY)	0~FF	00
D182	(NO DISPLAY)	0~FF	00
D183	(NO DISPLAY)	0~FF	00
D184	(NO DISPLAY)	0~FF	00
D185	(NO DISPLAY)	0~FF	00
D186	(NO DISPLAY)	0~FF	00
D187	(NO DISPLAY)	0~FF	00

SYSTEM SETTING [Do not adjust : All fixed]

Item No.	Item name	Variable range	Setting value
Z001	(NO DISPLAY)	0~0F	00
Z002	(NO DISPLAY)	0~0F	00
Z003	(NO DISPLAY)	0~0F	00
Z004	(NO DISPLAY)	0~FF	00
Z005	(NO DISPLAY)	0~FF	00
Z006	(NO DISPLAY)	0~FF	00
Z007	(NO DISPLAY)	0~FF	00
Z008	(NO DISPLAY)	0~FF	00
Z009	(NO DISPLAY)	0~FF	00
Z010	(NO DISPLAY)	0~FF	00

4.7 ADJUSTMENT PROCEDURE

4.7.1 OPTICAL BLOCK / DRIVE CIRCUIT

Item	Measuring instrument	Test point	Adjustment part	Description
LENS FOCUS adjustment	Hexagon wrench		FOCUS knob [PROJECTION LENS]	<ol style="list-style-type: none"> (1) Take out the FRONT PANEL, SPEAKER GRILL (L / R), CENTER PANEL and cushions. (2) Display the MENU screen. (3) Loosen the FOCUS LOCK screw. (4) Adjust the FOCUS knob so that the center screen may become the best focus. (5) Fix the focus lock screw by using the Hexagon wrench. <ul style="list-style-type: none"> • On this occasion, hold the FOCUS knob with your left hand. (6) Confirm the whole focus of the best screen (7) Install the FRONT PANEL, SPEAKER GRILL (L / R), BODY COVER and cushions.
DRIVE CONVERGENCE adjustment	Remote control unit			<ul style="list-style-type: none"> • Use the inner RGB box pattern. <ol style="list-style-type: none"> (1) Set the [SLEEP TIMER] key to 0 min. (2) Press the [DISPLAY] key and the [VIDEO STATUS] key simultaneously. (3) Press the [9] key to display the RGB box pattern. (4) Select the R mode by pressing the [DISPLAY] key. (5) Adjust the R mode to setting as same as G mode by pressing the [CH +] / [CH -] key. (6) Select the B mode pressing by the [DISPLAY] key. (7) Adjust the B mode to setting as same as G mode by pressing the [VOL -] / [VOL +] key. (8) Check to see that the cross pattern is white. If the cross pattern is not white, readjust (5) to (6). <p>Note</p> <ul style="list-style-type: none"> • G mode : FIXED mode (Can not remove) • Setting data : Memorized at once.
[REMOTE CONTROL UNIT KEY FUNCTION]				

Item	Measuring instrument	Test point	Adjustment part	Description
DRIVE CENTER POSITION adjustment	Signal generator Remote control unit			<p>(1) Input the center-cross signal pattern. (2) Set the [SLEEP TIMER] to 0 min. (3) Press the [DISPLAY] key and the [VIDEO STATUS] key simultaneously. (4) Press the [9] key to display the RGB box pattern. (5) Press the [DISPLAY] key twice to select the RGB mode. (6) Adjust the center-cross screen to be same on top and bottom (A=B) by pressing the [CH +] / [CH -] key. (7) Adjust the center-cross screen to be same on left and right (C=D) by pressing the [VOL +] / [VOL -] key.</p> <p>Note</p> <ul style="list-style-type: none"> Setting data : Memorized at once.

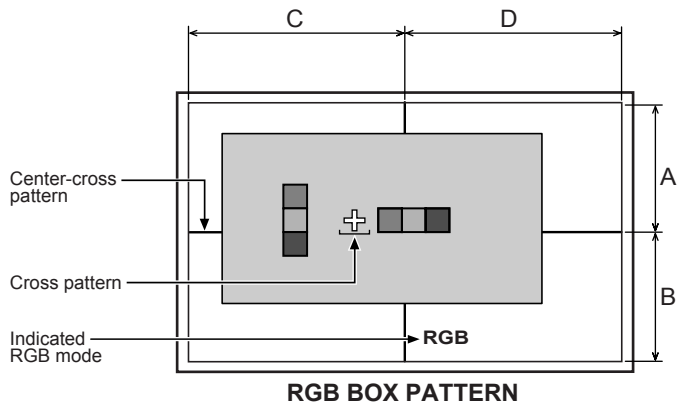

[REMOTE CONTROL UNIT KEY FUNCTION]

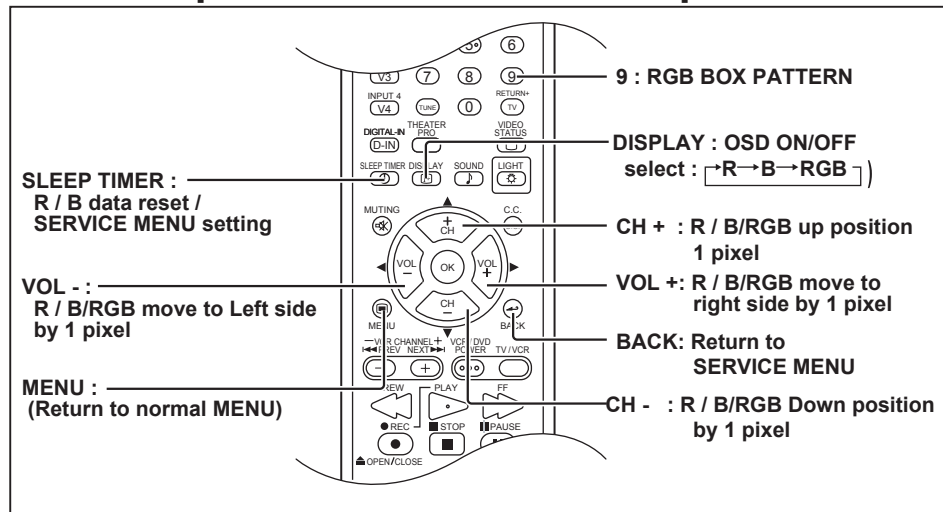

4.7.2 VIDEO CIRCUIT

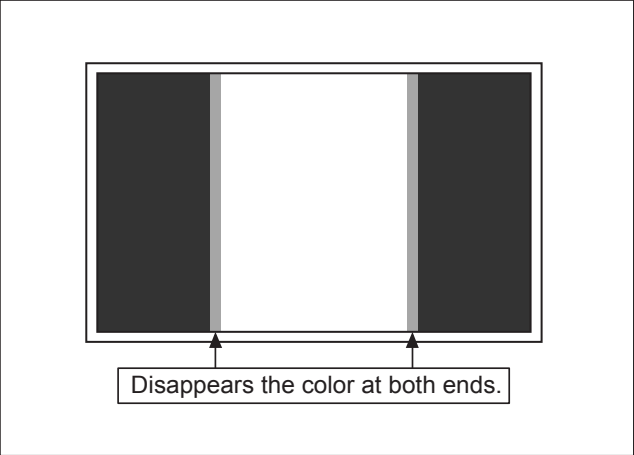
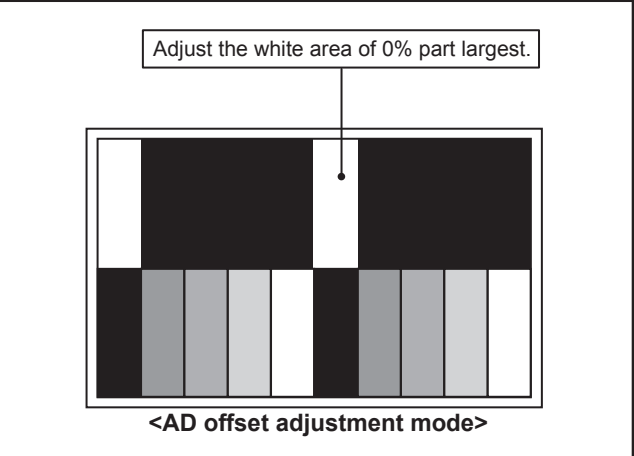
Item	Measuring instrument	Test point	Adjustment part	Description
525i A-D OFFSET adjustment	Signal generator Remote control unit		[1. ADJUST] S001: PREPARE S008: 5i CB OF (525i Cb offset) S009: 5i CR OF (525i Cr offset)	<ol style="list-style-type: none"> (1) Input a 525i ramp pattern from COMPONENT VIDEO INPUT terminal. (2) Set VIDEO STATUS to [STANDARD]. (3) Set ASPECT to [FULL]. (4) Set COLOR TEMPERATURE to [LOW]. (5) Select [1.ADJUST] from the SERVICE MENU. (6) Adjust < S001 >(PREPARE) from 000 to 008, goes into the [525i Cb offset] adjustment setting mode. (7) Adjust < S008 > (525i Cb offset) and < S009 > (525i Cr offset) to sets the lose gap (red line, green line and blue line) which disappears the colors at both ends of the center screen. (8) Press the [MUTING] key to memorized the set value. (9) Repeat from (6) and (7), then check to see that both ends color to white. (10) Adjust < S001 > from 008 to 000, it change to the normal mode.
				
1125i BRIGHTNESS adjustment	Signal generator Remote control unit		[1. ADJUST] S001:PREPARE S012:HD BL (1125i brightness) S030:R DRIVE (Red drive) S031:G DRIVE (Green drive) S032:B DRIVE (Blue drive)	<ol style="list-style-type: none"> (1) Input a 1125i gray scale pattern from COMPONENT VIDEO INPUT terminal. (2) Set VIDEO STATUS to [STANDARD]. (3) Set ASPECT to [FULL]. (4) Set COLOR TEMPERATURE to [LOW]. (5) Select [1.ADJUST] from the SERVICE MENU. (6) Adjust < S030 > (Red drive), < S031 > (Green drive) and < S032 > (Blue drive) to set the values [128]. (7) Adjust < S001 > (PREPARE) from 000 to 012, it goes to [A/D offset] adjustment mode. (8) Adjust < S012 > (HDBL) to set the 0% black part in the upper half of the screen to be largest. (9) Press the [MUTING] key to memorized the set value. (10) Adjust < S001 > from 012 to 000, it change to the normal mode.
				

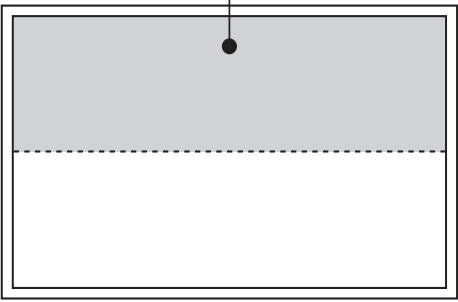
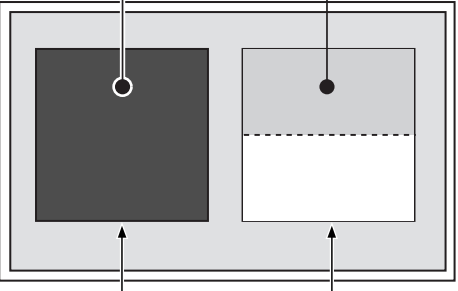
Item	Measuring instrument	Test point	Adjustment part	Description
1125i A-D OFFSET adjustment	Signal generator Remote control unit		[1. ADJUST] S001:PREPARE S013:HD CB OF (1125i Cb offset) S014:HD CR OF (1125i Cr offset) S030:R DRIVE (Red drive) S031:G DRIVE (Green drive) S032:B DRIVE (Blue drive)	<p>(1) Input a 1125i 30% all white pattern signal from COMPONENT VIDEO INPUT terminal.</p> <p>(2) Set VIDEO STATUS to [STANDARD].</p> <p>(3) Set ASPECT to [FULL].</p> <p>(4) Set COLOR TEMPERATURE to [LOW].</p> <p>(5) Select [1.ADJUST] from the SERVICE MENU.</p> <p>(6) Adjust < S030 > (Red drive), < S031 > (Green drive) and < S032 > (Blue drive) to set the values [128].</p> <p>(7) Adjust < S001 > (PREPARE) from 000 to 013, it goes to [Cb offset] adjustment mode.</p> <p>(8) Adjust < S013 > (1125i Cb offset) to minimize the blue noise in the upper half of the screen.</p> <p>(9) Adjust < S014 > (1125i Cr offset) to minimize the red noise in the upper half of the screen.</p> <p>(10) Press the [MUTING] key to memorized the set value.</p> <p>(11) Repeat from (8) to (10) then adjust the adjustment screen lightest color.</p> <p>(12) Adjust < S001 > (PREPARE) from 013 to 000, it change to the normal mode.</p>
<div style="border: 1px solid black; padding: 10px; text-align: center;"> <p>Minimize the red and blue noises in the upper half of the screen. (No color or lightest color)</p>  </div>				
SUB SCREEN A-D OFFSET adjustment	Signal generator Remote control unit		[1. ADJUST] S001:PREPARE S016:RT CB OF (Sub screen Cb offset) S017:RT CR OF (Sub screen Cr offset) S030:R DRIVE (Red drive) S031:G DRIVE (Green drive) S032:B DRIVE (Blue drive)	<p>(1) Set VIDEO STATUS to [STANDARD].</p> <p>(2) Set ASPECT to [FULL].</p> <p>(3) Set COLOR TEMPERATURE to [LOW].</p> <p>(4) Set MULTI SCREEN to [TWIN].</p> <p>(5) Set the LEFT screen to VIDEO-1 mode (No signal).</p> <p>(6) Receive a NTSC 30% all white signal on the RIGHT screen from RF(TV).</p> <p>(7) Select [1.ADJUST] from the SERVICE MENU.</p> <p>(8) Adjust < S030 > (Red drive), < S031 > (Green drive) and < S032 > (Blue drive) to set the values [128].</p> <p>(9) Adjust < S001 > (PREPARE) from 000 to 016, it goes to [Sub-screen Cb offset] adjust mode.</p> <p>(10) Adjust < S016 > (Sub-screen Cb offset) to minimize the blue noise in the upper half of the screen. If you select < S016 >, the screen automatically turn to adjust mode.</p> <p>(11) Adjust < S017 > (Sub-screen Cr offset) to minimize the red noise in the upper half of the screen.</p> <p>(12) Press the [MUTING] key to memorized the set value.</p> <p>(13) Adjust < S001 > (PREPARE) from 016 to 000, it change to the normal mode.</p>
<div style="border: 1px solid black; padding: 10px;"> <div style="display: flex; justify-content: space-around; margin-bottom: 10px;"> <div style="border: 1px solid black; padding: 2px;">Video no signal.</div> <div style="border: 1px solid black; padding: 2px;">Set the 0% black part to be brightest.</div> </div>  <div style="display: flex; justify-content: space-around; margin-top: 10px;"> <div style="text-align: center;">VIDEO-1 <No signal></div> <div style="text-align: center;">TV (RF) <30% all white></div> </div> </div>				

Item	Measuring instrument	Test point	Adjustment part	Description
WHITE BALANCE (High light) adjustment	Signal generator Remote control unit		[1. ADJUST] S030:R DRIVE (Red drive) S031:G DRIVE (Green drive) S032:B DRIVE (Blue drive)	<ol style="list-style-type: none"> (1) Receive a NTSC all-white (75% white) pattern signal. (2) Set VIDEO STATUS to [STANDARD]. (3) Set ASPECT to [FULL]. (4) Set COLOR TEMPERATURE to [LOW]. (5) Select [1.ADJUST] from the SERVICE MENU. (6) Fix one of < S030 > (Red drive), < S031 > (Green drive) or < S032 > (Blue drive). Then, lower the other two that are not fixed so that the all-white screen is equally white throughout. (7) Adjust one or more of < S030 > (R.DRIVE), < 031 > (G DRIVE) and < 032 > (B DRIVE) to set values [128]. (8) Check that white balance is properly tracked from low light to high light. If the white balance tracking is deviated, adjust to correct it. (9) Press the [MUTING] key to memorized the set value.

4.7.3 MTS CIRUT

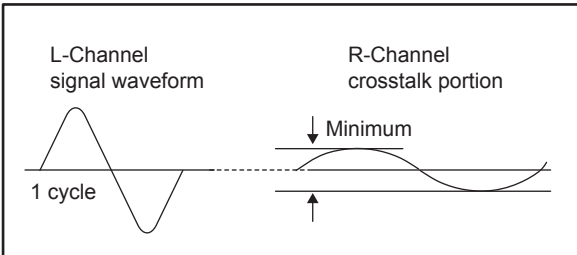
Item	Measuring instrument	Test point	Adjustment part	Description
MTS INPUT LEVEL adjustment	Remote control unit		[1. ADJUST] T001:IN LEVEL	<ol style="list-style-type: none"> (1) Select the [1.ADJUST] from the SERVICE MENU. (2) Select the <T001> (IN LEVEL). (3) Set the <T001> (IN LEVEL) to initial setting value. (4) Press the [MUTING] key to memorized the set value.
MTS SEPARATION adjustment	TV audio multiplex Oscilloscope Remote control unit		[1. ADJUST] T002: LOW SEP T003: HIGH SEP	<ol style="list-style-type: none"> (1) Input stereo L signal (300Hz) from the TV audio multiplex signal generator to the antenna terminal. (2) Connect an oscilloscope to L OUTPUT pin of the AUDIO OUT, and display one cycle portion of the 300Hz signal. (3) Change the connection of the oscilloscope to R OUTPUT pin of the AUDIO OUT, and enlarge the voltage axis. (4) Select <T002> (LOW SEP.). (5) Set the initial setting value of <T002> (LOW SEP.). (6) Adjust <T002> (LOW SEP.) so that the stroke element of the 300Hz signal will become minimum. (7) Change the signal to 3kHz, and similarly adjust <T003> (HIGH SEP.). (8) Press the [MUTING] key to memorized the set value.
				

SECTION 5 TROUBLESHOOTING

5.1 SELF-CHECK FEATURE

5.1.1 OUTLINE

This unit comes with the SELF-CHECK feature, which checks the operational state of the circuit and displays/saves it during failure. SELF-CHECK is performed when power is turned on, and information input to the main microcomputer is monitored at all time. SELF-CHECK is displayed in 2 ways via screen display and LED flashes. Failure detection is based on input state of I²C bus and the various control lines connected to the main microcomputer.

5.1.2 HOW TO ENTER THE SELF-CHECK DISPLAY SCREEN

Before entering the SELF-CHECK display mode, confirm that the setting of TV / CATV SW of the REMOTE CONTROL UNIT is at the "TV" side and the setting of VCR / DVD SW is at the "VCR" side. If the switches have not been properly set, you cannot enter the SELF-CHECK display mode.

- (1) Press the [SLEEP TIMER] key and set it to 0 minutes.
- (2) Press the [VIDEO STATUS] key and [DISPLAY] key simultaneously, then enter the SERVICE MENU.
- (3) Press the [2] key to enter the SELF-CHECK mode.

5.1.3 HOW TO EXIT THE SELF-CHECK DISPLAY SCREEN TO SAVE FAILURE HISTORY :

Turn off the power by unplugging the AC power cord plug when in the SELF-CHECK mode.

TO CLEAR (RESET) FAILURE HISTORY :

Turn off the power by pressing the [POWER] key on the remote control unit when in the SELF-CHECK display screen.

5.1.4 FAILURE HISTORY

Failure history can be counted up to 9 times for each item. When the number exceeds 9, display will remain as 9. Failure history will be stored in the memory unless it has been deleted.

NOTE :

Only SYNC (with/without sync signals) will be neither counted nor stored.

5.1.5 POINTS TO NOTE WHEN USING THE SELF-CHECK FEATURE

In addition to circuit failures (abnormal operation), the following cases may also be SELF-CHECK as "Abnormal" and displayed and counted as "NG".

- (1) Temporary defective transmissions across circuits due to pulse interruptions.
- (2) Misalignment in the on/off timing of power for I²C bus (VCC) when turning on/off the main power.

SELF-CHECK may be impeded if a large number of items are displayed as "NG". As such, start SELF-CHECK only after 3 seconds in the case of receivers and 5 seconds in the case of panels upon turning on the power. If recurrences are expected, ensure to clear (reset) the failure history and record the new SELF-CHECK results.

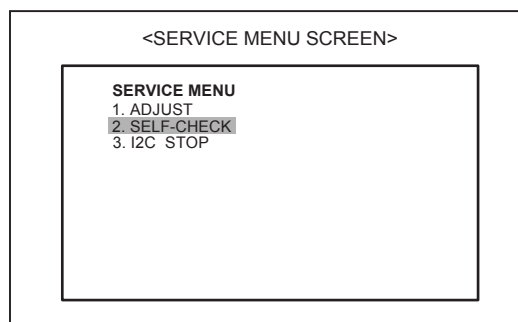

Fig.1

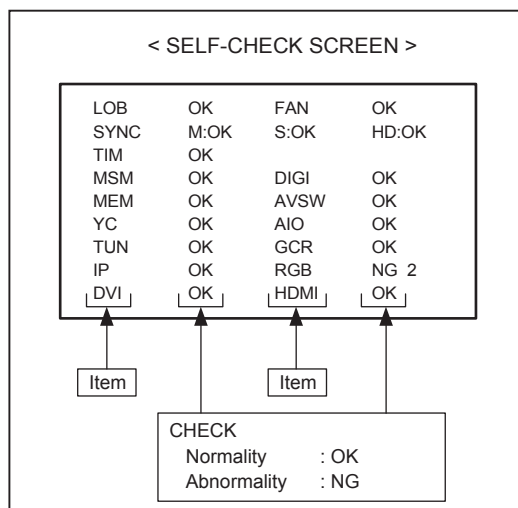

Fig.2

5.1.6 DETAILS

Self-check is performed for the following items.

Check item	Display	Description of detection	Diagnosis signal (line)	Means of detection
Low bias line short protection	LOB	Low bias line (9V / 5V) short protector activated. Confirm the operation of the low bias protection circuit. [Q2802 /Q2801] (REGULATOR PWB)	Protector	Detection starts 3 seconds upon power on Turns off power if NG is detected within 400ms.
Fan lock (stop)	FAN	Confirmation of operating stop of heat cooling fan. [IC8005 : 1 / 2 / 4 / 5-pin] (FAN CONTROL PWB)	Protector	Detection starts 3 seconds upon power on Turns off power if NG is detected within 250ms.
AC timer clock	TIM	Not used	---	---
Presence of sync signal	SYNC	Confirmation of presence of video sync signal. M : Main sync signal S : Sub sync signal HD : Component sync signal [IC201] (ANALOG SIGNAL PWB)	SDA	Confirmation of presence of video sync signal.
MAIN CPU communication	MSM	Confirmation of ACK (response) signal which used sync communications with Chassis CPU. [IC7601] (DIGITAL SIGNAL PWB)	WAKE	If it checks whenever sync communication with SHM performed and no reply of ACK signal an error will be counted.
Digital tuner	DIGI	Not used	---	---
Memory for chassis CPU	MEM	Confirmation of reply of ACK signal which used I ² C communication. [IC7602] (DIGITAL SIGNAL PWB)	SDA	If checks whenever I ² C communication is performed and no reply of ACK signal an error will be counted.
AV switch	AVSW	Same as above [IC501] (ANALOG SIGNAL PWB)	SDA	Same as above
3D YC separation	YC	Same as above [IC1001] (DIGITAL SIGNAL PWB)		
Audio process	AIO	Same as above [IC1140] (RECEIVER PWB)		
RF tuner	TUN	Same as above [TU1101] (RECEIVER PWB)		
Ghost reduction	GCR	Not used	---	---
DIST process	IP	Confirmation of reply of ACK signal which used I ² C communication. [IC3001] (DIGITAL SIGNAL PWB)	SDA	If checks whenever I ² C communication is performed and no reply of ACK signal an error will be counted.
RGB process	RGB	Same as above [IC4001] ((DIGITAL SIGNAL PWB)		
DVI transmission	DVI	Not used	---	---
Digital input receive	HDMI	Confirmation of reply of ACK signal which used I ² C communication. [IC8001] (DIGITAL SIGNAL PWB)	SDA	If checks whenever I ² communication is performed and no reply of ACK signal an error will be counted.

5.1.7 DISPLAY METHOD WHEN RASTER IS NOT AVAILABLE

In a state where a display screen does not appear due to the failure of this unit, the POWER LED (blue) and LAMP LED (orange) can light up and display a trouble mode.

The factors in case the power is forcibly shut down at the time of failure are memorized and those are displayed.

Check item	Contents	Classifications	LED flash cycle	
			POWER LED	LAMP LED
Lamp does not light up	Detection of lamp return (LAMP_RTN) signals output depending on the status of the lamp supply electric current monitored constantly within the lamp ballast unit. (H = Off) [LAMP BALLAST UNIT : CN200 [3pin]]	3	0.1 sec interval Simultaneously	0.1 sec interval Simultaneously
Lamp goes out	Detection of lamp return (LAMP_RTN) signals output depending on the status of the lamp supply electric current monitored constantly within the lamp ballast unit. (H = Off) [LAMP BALLAST UNIT : CN200 [3pin]]	3	0.1 sec interval Simultaneously	0.1 sec interval Simultaneously
Abnormal DD CPU circuit	Detection of serial communication error between MAIN DRIVE PWB and RECEIVER PWB. [IC3701 [5 / 7pin]] (MAIN DRIVE PWB)	2	-----	0.5 sec interval
Fan lock (stop)	Detection of LOCK signals outputting the operation (circuit) status of the cooling fan. (H=Abnormal) [IC8005 : 1 / 2 / 4 / 5-pin] (FAN CONTROL PWB)	1	0.5 sec interval Alternately	0.5 sec interval Alternately
Lamp cover open	Detection of the interlock switch status for the lamp cover. (H = Abnormal) [S0201] (LAMP COVER SW PWB)	3	0.1 sec interval Simultaneously	0.1 sec interval Simultaneously
Abnormal D-ILA DEVICE temperature	Detection of abnormal inner cabinet temperature. (53°C) [IC2001] (TEMPERATURE SENSOR PWB)	1	0.5 sec interval Alternately	0.5 sec interval Alternately

EXPLANATION ON ACTION

If NG is detected on an item being diagnosed, turn off the power on this unit. As soon as the power goes off, turn on and off POWER LED and LAMP LED immediately. After the power is shut down, it becomes impossible to turn on the power until the power cable is either plugged in or unplugged from the AC outlet.

- When [1] and [3] take place at the same time, give priority to [1], and [2] will not take place simultaneously with [1] and [3].

JVC SERVICE & ENGINEERING COMPANY OF AMERICA
DIVISION OF JVC AMERICAS CORP.

www.jvcservice.com(US Only)

JVC CANADA INC.

Head office : 21 Finchdene Square Scarborough, Ontario M1X 1A7

(416)293-1311

JVC[®]

(No.YA092B)