



COLOUR TELEVISION

SP43T8
SP42W4
SP43W6
SP42Q2

Owner's Instructions

Before operating the unit,
please read this manual thoroughly,
and retain it for future reference.

**ON-SCREEN MENUS
TELETEXT
SELF FOCUS**



Important Warranty Information Regarding Television Format Viewing

ENG

Standard screen format televisions (4:3, the aspect ratio of the screen width to height) are primarily designed to view standard format full-motion video. The images displayed on them should primarily be in the standard 4:3 ratio format and constantly moving. Displaying stationary graphics and images on screen, such as the dark top and bottom letterbox bars (wide screen pictures), should be limited to no more than 15% of the total television viewing per week.

Wide screen format televisions (16:9, the aspect ratio of the screen width to height) are primarily designed to view wide screen format full-motion video. The images displayed on them should primarily be in the wide screen 16:9 ratio format, or expanded to fill the screen if your model offers this feature, and constantly moving. Displaying stationary graphics and images on screen, such as the dark side-bars on non-expanded standard format television video and programming, should be limited to no more than 15% of the total television viewing per week.

Additionally, viewing other stationary images and text such as stock market reports, video game displays, station logos, web sites or computer graphics and patterns, should be limited as described above for all televisions. ***Displaying any stationary images that exceed the above guidelines can cause uneven aging of picture tubes (CRTs) that leave subtle, but permanent burned-in ghost images in the television picture. To avoid this, vary the programming and images, and primarily display full screen moving images, not stationary patterns or dark bars.*** On television models that offer picture sizing features, use these controls to view the different formats as a full screen picture.

Be careful in the selection and duration of television formats used for viewing. Uneven CRT aging as a result of format selection and use, as well as other burned-in images, is not covered by your Samsung limited warranty.

Contents

◆ FOREWORD	
■ Important Warranty Information Regarding Television Format Viewing	3
◆ CONNECTING AND PREPARING YOUR TELEVISION	
■ Control Panels (depending on the model)	6
■ Connection Panels (depending on the model)	7
■ Using a Display Deck (depending on the model)	8
■ Inserting the Batteries in the Remote Control	8
■ Infrared Remote Control	9
■ Connecting to an Aerial or Cable Television Network	10
■ Connecting a Satellite Receiver or Decoder	11
■ Switching Your Television On and Off	12
■ Placing Your Television in Standby Mode	12
■ Becoming Familiar with the Remote Control	13
■ Plug and Play Feature	14~15
■ Displaying Information	15
■ Choosing Your Language	16
■ Adjusting the Screen Automatically (Self Focus)	17
■ Deactivating the Automatic Execution of the Self Focus	18
■ Removing the "Self Focus" from the Display	19
◆ SETTING THE CHANNELS	
■ Storing Channels Automatically	20
■ Sorting the Stored Channels	21
■ Storing Channels Manually	22~23
■ Skipping Unwanted Channels	24
■ Assigning Names to Channels	25
■ Locking the Channel	26
■ Fine Tuning Channel Reception	27
◆ USING YOUR TELEVISION	
■ Using the LNA (Low Noise Amplifier) Feature	28
■ Changing the Picture Standard	29
■ Customizing the Picture Settings	30
■ Selecting the Picture Size (4:3 Model)	31
■ Selecting the Picture Size (Wide Model)	32~33
■ Selecting the Scan Mode	34
■ Using the Digital NR (Digital Noise Reduction) Feature	35
■ Setting the Blue Screen Mode	36
■ Freezing the Current Picture	36
■ Changing the Sound Standard	37
■ Adjusting the Sound Settings	38

Contents (continued)

◆ USING YOUR TELEVISION (continued)	
■ Extra Sound Settings.....	39
- Auto volume	
- Dolby Virtual	
■ Setting the Melody Sound	40
■ Selecting the Sound Mode (depending on the model)	41
■ Setting and Displaying the Current Time.....	42
■ Setting the Sleep Timer	43
■ Switching the Television On and Off Automatically.....	44
■ Viewing an External Signal Source	45
◆ USING THE TELETEXT FEATURE	
■ Teletext Feature	46
■ Displaying the Teletext Information	47
■ Selecting Display Options.....	48
■ Selecting a Teletext Page.....	49
■ Storing Teletext Pages (depending on the model)	50
◆ ADDITIONAL INFORMATION ON CONNECTIONS	
■ Connecting to the External Input/Outputs.....	51
■ Connecting to the Audio Output	52
■ Connecting to the RCA Input.....	53
■ Connecting to the S-Video Input.....	54
■ Connecting to the Component Input.....	55
■ Redirecting an Input to the External Output	56
◆ RECOMMENDATIONS FOR USE	
■ Programming the Remote Control for Other Components	57~59
- VCR Remote Control Codes	58
- DVD Remote Control Codes	58
- Cable Box (CATV) Remote Control Codes	59
■ Troubleshooting: Before Contacting Service Personnel.....	60

Symbols



Control Panels (depending on the model)

ENG

➤ The actual configuration on your TV may be different, depending on your model.

SP43T8

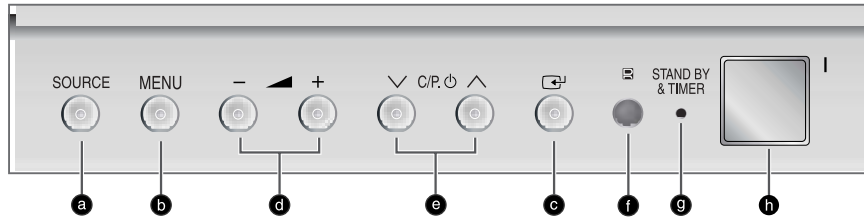

SP43W6

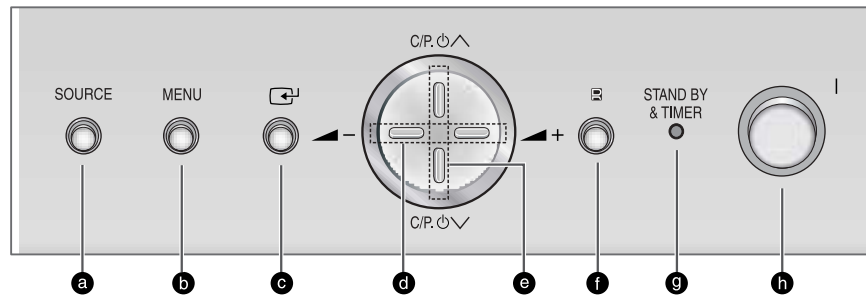

SP42W4

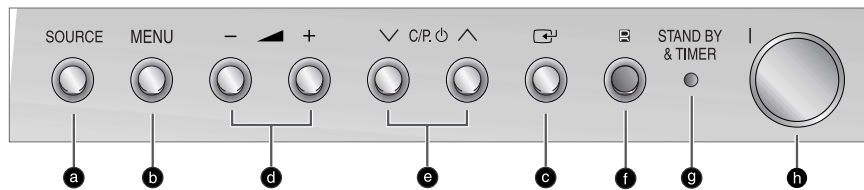

SP42Q2

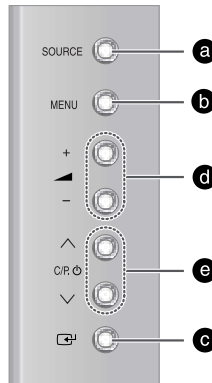
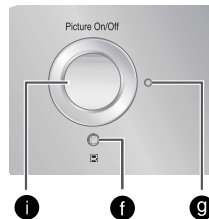

- | | |
|---|-------------------------------|
| (a) Input Source Selection | (e) Channel Selection |
| (b) Menu Display | (f) Remote Control Sensor |
| (c) Accessing to the Selected Option on the Menu System | (g) Standby & Timer Indicator |
| (d) Volume Adjustment | (h) Power On/Off |
| | (i) Picture On/Off |

➤ Using the Buttons on the Panel

If the remote control no longer works or you have lost it, you can use controls on the panel of the TV to:

- ◆ Switch on the TV when it is in Standby mode and select channels (⏶ C/P.⏻ ⏷)
- ◆ Access the menu (**MENU**)
- ◆ Adjust the volume (- ▲ +)
- ◆ Switch among Video input modes (**SOURCE**) and access to the selected option on the menu system (⏸)

Connection Panels (depending on the model)

- The actual configuration on your TV may be different, depending on your model.

ENG

Side of the TV

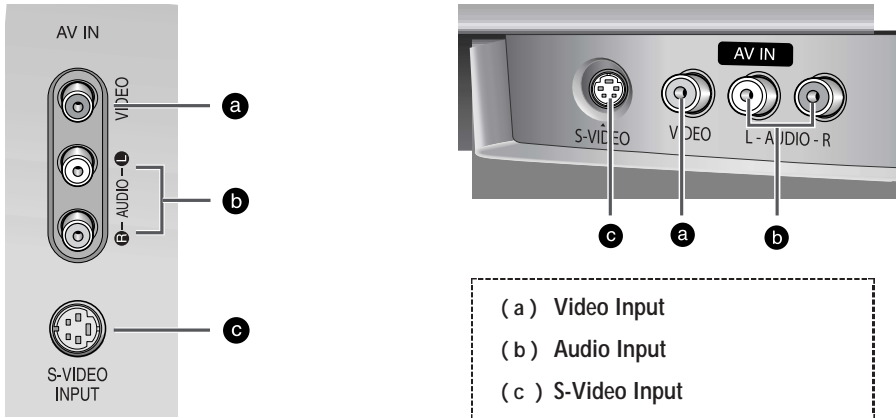

Rear of the TV

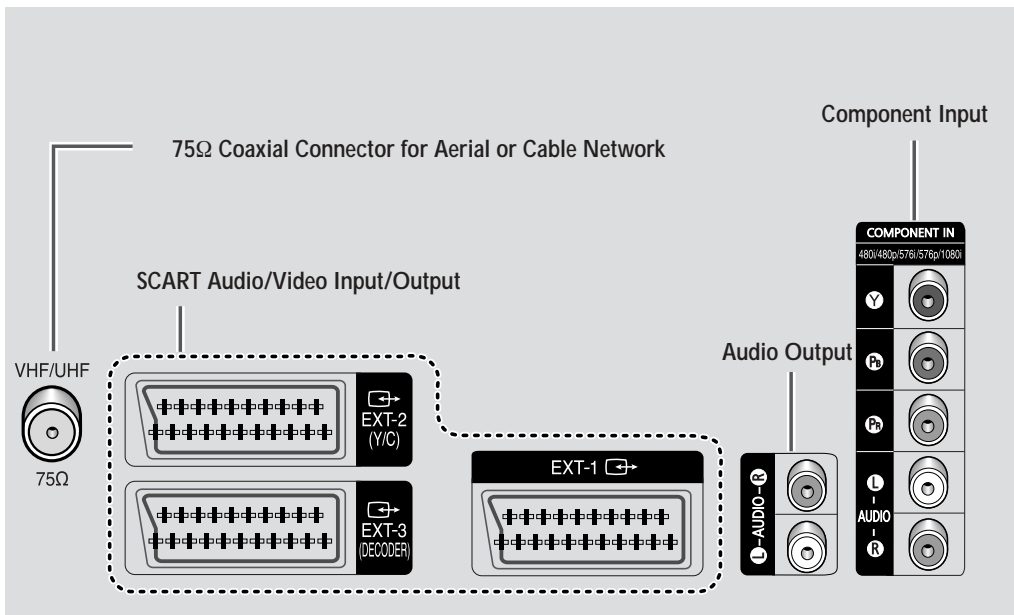

- For further details about connection, refer to pages 51~55.

- ✋ Whenever you connect an audio or video system to your television, ensure that all elements are switched off. Refer to the documentation supplied with your equipment for detailed connection instructions and associated safety precautions.

Using a Display Deck (depending on the model)

SP43W6

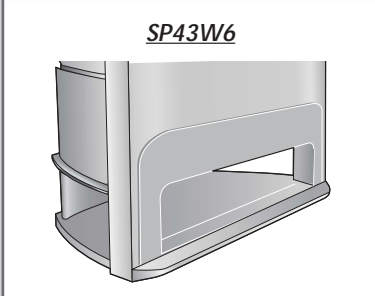

You can display a VCR or DVD Player, etc. by using the display deck.

Inserting the Batteries in the Remote Control

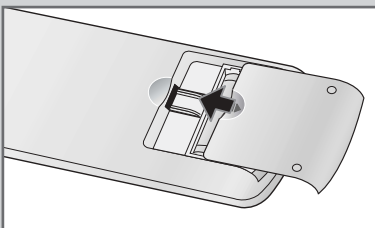
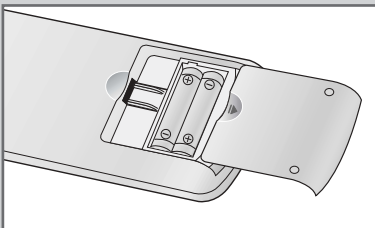
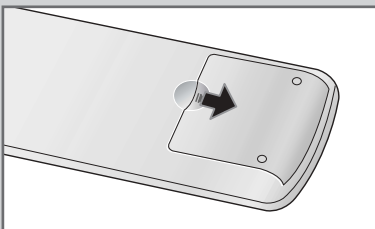

You must insert or replace the batteries in the remote control when you:

- ◆ *Purchase the television*
- ◆ *Find that the remote control is no longer operating correctly*

- 1 Remove the cover on the rear of the remote control by pressing the symbol (▼) downwards and then pulling firmly to remove it.
- 2 Insert two R03, UM4, "AAA" 1.5V or equivalent batteries taking care to respect the polarities:
 - ◆ + on the battery against + on the remote control
 - ◆ - on the battery against - on the remote control
- 3 Replace the cover by aligning it with the base of the remote control and pressing it back into place.

Infrared Remote Control

ENG

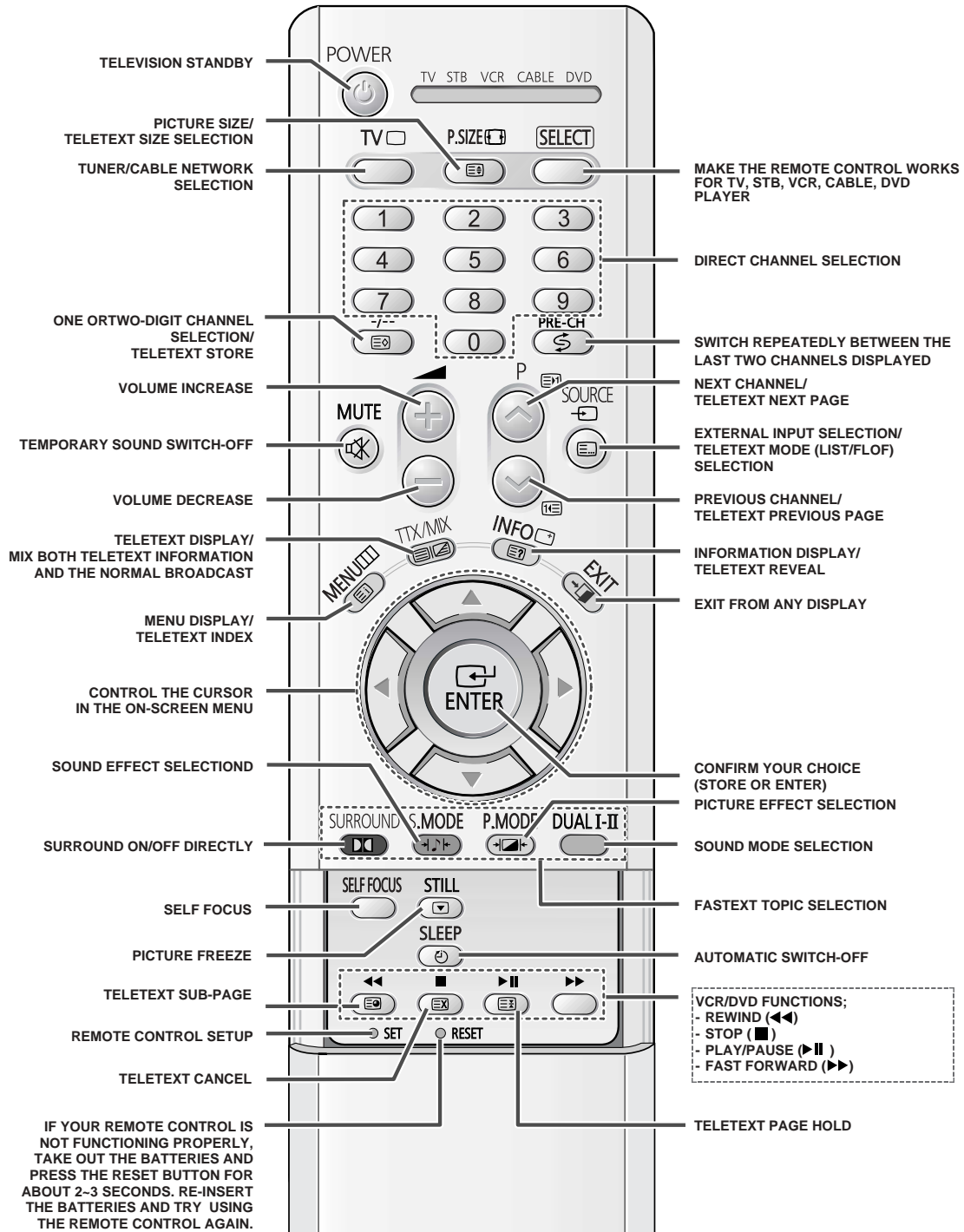

➤ The performance of the remote control may be affected by bright light.

Connecting to an Aerial or Cable Television Network

ENG

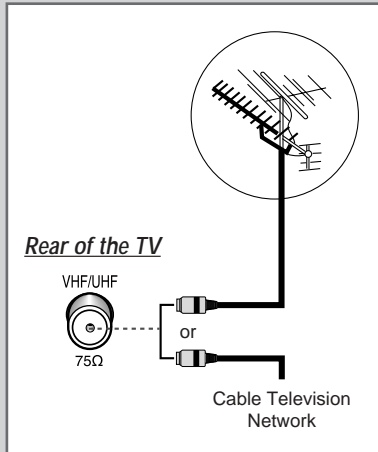

To view television channels correctly, a signal must be received by the set from one of the following sources:

- ◆ An outdoor aerial
- ◆ A cable television network
- ◆ A satellite network

1 In the first three cases, connect the aerial or network input cable to the 75Ω coaxial socket on the rear of the television.

2 If you are using an indoor aerial, you may need to turn it when tuning your television until you obtain a picture that is both sharp and clear.

For further details, refer to:

- ◆ "Storing Channels Automatically" on page 20.
 - ◆ "Storing Channels Manually" on page 22.
-

Connecting a Satellite Receiver or Decoder

ENG

In order to watch television programmes broadcast via a satellite network, you must connect a satellite receiver to the rear of TV. Also, in order to descramble a coded transmission signal, you must connect a decoder to the rear of TV.

◆ **Using a SCART cable**

Connect the receiver (or decoder) SCART cable to one of the SCART connectors on the rear of the television.

◆ **Using a coaxial cable**

- Connect a coaxial cable to the:
- Receiver (or Decoder) output socket.
 - Television aerial input socket.

➤ If you wish to connect both a satellite receiver (or decoder) and a VCR, you should connect the:

- ◆ Receiver (or Decoder) to the VCR
- ◆ VCR to the television

Otherwise, connect the receiver (or decoder) directly to the television.

Rear of the TV

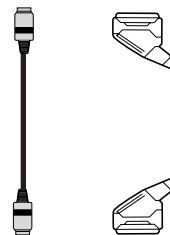
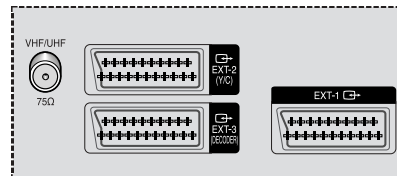

Satellite receiver/ Decoder

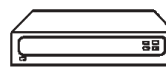

Switching Your Television On and Off

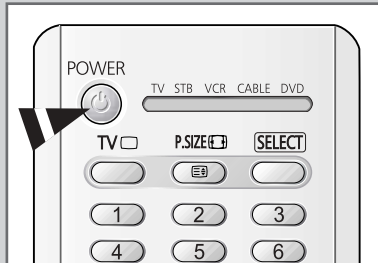

The mains lead is attached to the rear of your television.

- 1 Plug the mains lead into an appropriate socket.
 - The main voltage is indicated on the rear of the television and the frequency is 50 or 60Hz.

- 2 Press the "I" button (On/Off) on the front or side of the television.

Result: The Standby indicator on the front of the television lights up.

- 3 Press the **POWER** (⏻) button on the remote control to switch the television on.

Result: The programme that you were watching last is re-selected automatically.

 - If you have not yet stored any channels, No clear picture appears. Refer to "Storing Channels Automatically" on page 20 or "Storing Channels Manually" on page 22.

- 4 To switch your television off, press the "I" button (On/Off) again.

Placing Your Television in Standby Mode

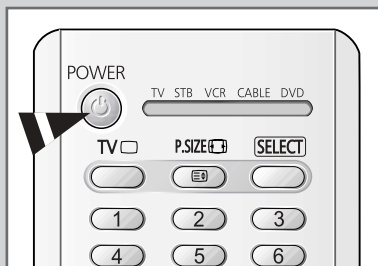

Your television can be placed in Standby mode, in order to reduce the power consumption.

The Standby mode can be useful when you wish to interrupt viewing temporarily (during a meal, for example).

- 1 Press the **POWER** (⏻) button on the remote control.

Result: The screen is turned off and the Standby indicator on the front of the television lights up in red.

- 2 To switch the television back on, simply press the **POWER** (⏻) button again.
 - You can also switch on by pressing the **TV** (□) or **P** (⏻) button.

✋ Do not leave your television in Standby mode for long periods of time (when you are away on holiday, for example). Turn your television off by pressing the "I" button (On/Off) on the front or side of the television. It is best to unplug the set from the mains and aerial.















Becoming Familiar with the Remote Control

ENG

The remote control is used mainly to:

- ◆ Change channels and adjust the volume
- ◆ Set up the television using the on-screen menu system

The following table presents the most frequently used buttons and their functions.

Button	Viewing Function	Menu Function
	Used to display the next stored channel.	—
	Used to display the previous stored channel.	—
	Used to display the corresponding channels. ➤ For double digit channels, the second digit must be pushed immediately after the first. Failure to do this will result in a single digit channel being displayed.	—
	Used to select a channel numbered ten or over. Press this button, and the “10” symbol is displayed. Enter the two-digit channel number.	—
PRE-CH ()	Press the PRE-CH button. The TV will switch to the last channel viewed. To quickly switch between two channels that are far apart, tune to one channel, then use the numeric buttons to select second channel. Then, use the PRE-CH button to quickly alternate between them.	—
	Used to increase the volume.	—
	Used to decrease the volume.	—
MUTE ()	Used to switch the sound off temporarily. ➤ To turn the sound back on, press this button again, or press the  or  button.	—
MENU ()	Used to display the on-screen menu system.	Used to return to the previous menu or normal viewing.
	—	Used to: ◆ Display a submenu containing selections for the current menu option. ◆ Increase/decrease a menu option value.
	—	Used to confirm your choice.
TV ()	Used to switch the television on when it is in Standby mode.	Used to exit from the menu system and return to normal viewing directly.
EXIT ()	—	Used to exit from the any display.

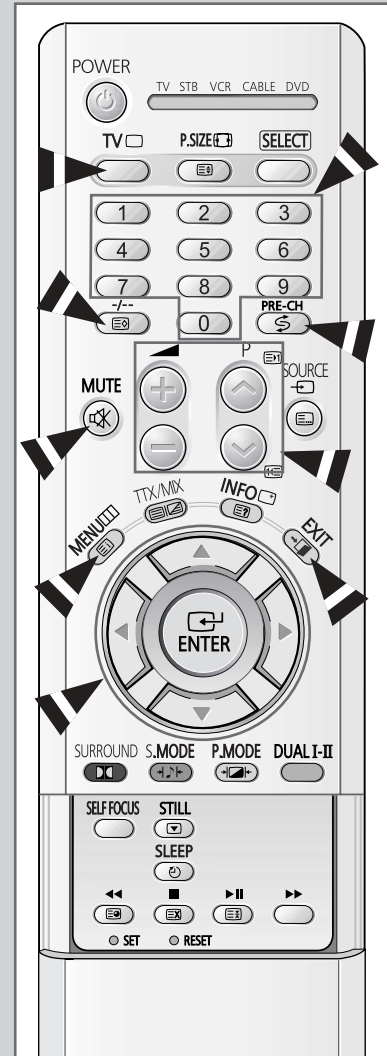

Plug and Play Feature

ENG

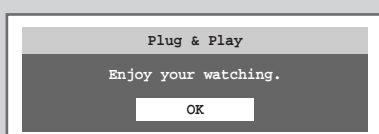
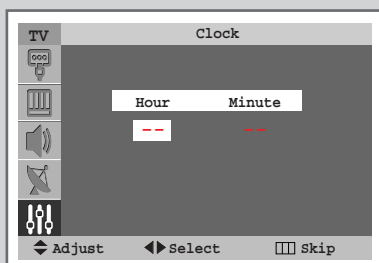
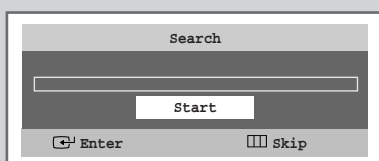
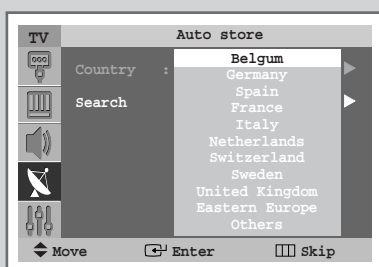
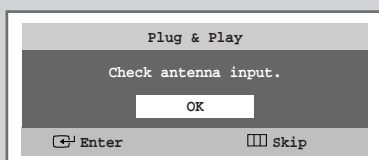
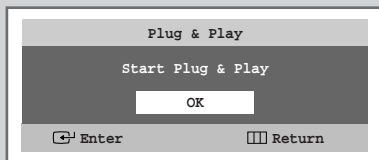



When the television is initially powered ON, several basic customer settings proceed automatically and subsequently. The following settings are available.

- 1 If the television is in Standby mode, press the **POWER** (⏻) button on the remote control.
Result: The message **start Plug & Play** is displayed.
- 2 To start the Plug & Play, press the **ENTER** (↵) button.
Result: The options available in the **Setup** group are displayed with **Language** is selected.
- 3 Select the appropriate language by pressing the ▲ or ▼ button. Press the **ENTER** (↵) button to confirm the language.
Result: The message **Check antenna input.** is displayed.
- 4 Make sure that the antenna is connected to the TV, and then press the **ENTER** (↵) button.
Result: The **Auto store** menu is displayed with **Country** is selected.
- 5 Select your country by pressing the ▲ or ▼ button. Press the **ENTER** (↵) button to confirm your choice.
Result: The **search** menu is displayed.
- 6 To start the channel store, press the **ENTER** (↵) button.
Result: The search will end automatically. Channels are sorted and stored in an order which reflects their position in the frequency range (with lowest first and highest last). When it has finished, the **clock** menu is displayed.
➤ To stop the search before it has finished or return to normal viewing, press the **MENU** (⏸) button.
- 7 Press the ◀ or ▶ button to move to the **Hour** or **Minute**. Set the hour or minute by pressing the ▲ or ▼ button.
- 8 Press the **ENTER** (↵) button.
- 9 When the setting has finished all, the message **Enjoy your watching.** is displayed, and then the channel which has been stored will be activated.

Plug and Play Feature (continued)

ENG

If you want to reset this feature...

- 1 Press the **MENU** () button.
Result: The main menu is displayed.
- 2 Press the **▲** or **▼** button until the **Setup** is selected.
Result: The options available in the **Setup** group are displayed.
- 3 Press the **ENTER** () button.
- 4 Press the **▲** or **▼** button until the **Plug & Play** option is selected.
Press the **ENTER** () button.
Result: This feature starts with the message **Start Plug & Play** is displayed.
- 5 For further details on how to set, refer to the opposite page.

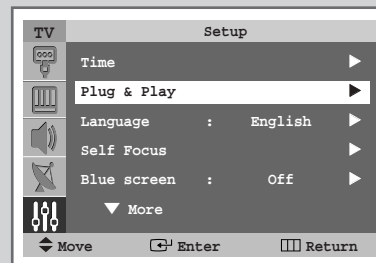

Displaying Information

You can view the channel information and setting status you select by pressing the "INFO ()" button on the remote control.

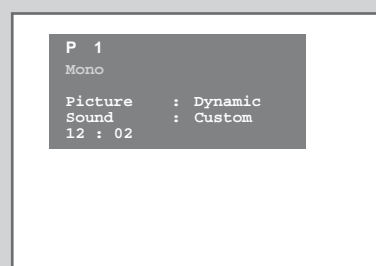

Choosing Your Language

ENG

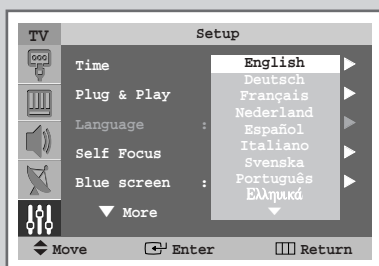
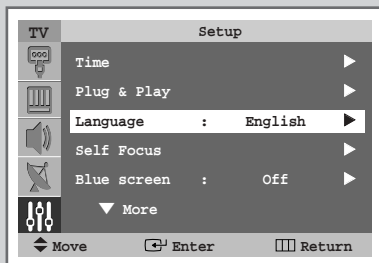

When you start using your television for the first time, you must select the language which will be used for displaying menus and indications.

- 1 Press the **MENU** () button.
Result: The main menu is displayed.
- 2 Press the **▲** or **▼** button until the **Setup** is selected.
Result: The options available in the **Setup** group are displayed.
- 3 Press the **ENTER** () button.
- 4 Press the **▲** or **▼** button until the **Language** is selected. Press the **ENTER** () button.
Result: The languages available are listed.
- 5 Select the appropriate language by pressing the **▲** or **▼** button. Press the **ENTER** () button to confirm your choice.

Adjusting the Screen Automatically (Self Focus)

ENG

The "Self Focus" feature automatically finds the optimum picture quality when blurring, overlapping colours or incorrect focus occurs. These conditions may be caused by moving your TV.

- 1 Press the **MENU** () button.
Result: The main menu is displayed.
- 2 Press the **▲** or **▼** button until the **Setup** is selected.
Result: The options available in the **Setup** group are displayed.
- 3 Press the **ENTER** () button.
- 4 Press the **▲** or **▼** button until the **Self Focus** is selected.
Press the **ENTER** () button.
Result: The **Self Focus** is selected.
- 5 Press the **ENTER** () button again
Result: The self focus process begins with the message **Self Focus** and horizontal bar is displayed. During the process, minor distortions of the picture may occur. At this time, the colors may diffuse and a searching action will appear on the edges of the screen. This is a normal part of the adjustment. When it is finished, all of things will disappear and the optimum picture quality can be enjoyed.

➤ You can also set these options simply by pressing the **SELF FOCUS** button.

- ◆ Changing channels and any other signal changes will pause the self focus until a stable signal has returned. It resumes after the signal has been stabilised. This feature will not work without a signal.
- ◆ Ambient light that is too bright may affect the self focus. If this occurs, darken the environment and try again.

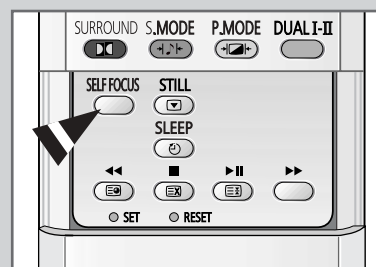
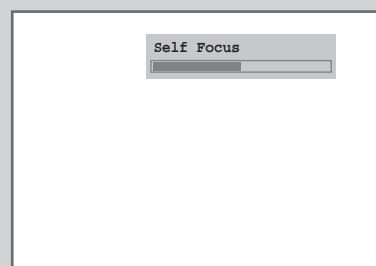
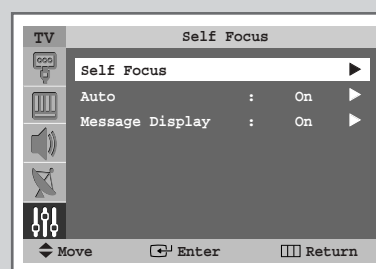
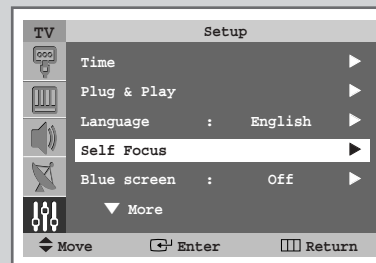

Deactivating the Automatic Execution of the Self Focus

ENG

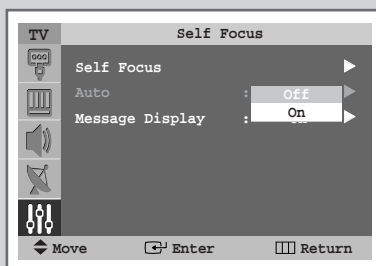





The "Self Focus" feature starts on default. It will automatically begin 1 minutes after switching on the power and the appearance of the screen image. To set the optimum picture quality, the "Self Focus" will automatically begin again after another 10 minutes, as the screen image is then fully stabilised.

- 1 Press the **MENU** () button.
Result: The main menu is displayed.
- 2 Press the **▲** or **▼** button until the **Setup** is selected.
Result: The options available in the **Setup** group are displayed.
- 3 Press the **ENTER** () button
- 4 Press the **▲** or **▼** button until the **Self Focus** is selected.
Press the **ENTER** () button.
Result: The options available in the **Self Focus** group are displayed.
- 5 Press the **▲** or **▼** button until the **Auto** is selected.
Press the **ENTER** () button.
- 6 To turn off the automatic execution of the self focus feature, select **Off** by pressing the **▲** or **▼** button. Press the **ENTER** () button to confirm.

Removing the " Self Focus" from the Display

ENG

- 1 Press the **MENU** () button.
Result: The main menu is displayed.
- 2 Press the **▲** or **▼** button until the **Setup** is selected.
Result: The options available in the **Setup** group are displayed.
- 3 Press the **ENTER** () button.
- 4 Press the **▲** or **▼** button until the **Self Focus** is selected.
Press the **ENTER** () button.
Result: The options available in the **Self Focus** group are displayed.
- 5 Press the **▲** or **▼** button until the **Message Display** is selected.
Press the **ENTER** () button.
- 6 To remove the message **Self Focus** and horizontal bar on the screen during the self focus process, select **off** by pressing the **▲** or **▼** button. Press the **ENTER** () button to confirm.

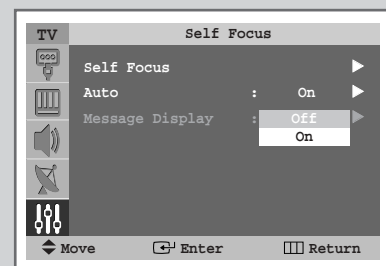
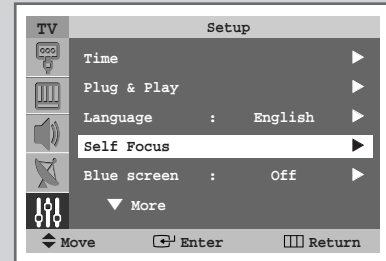

Storing Channels Automatically

ENG

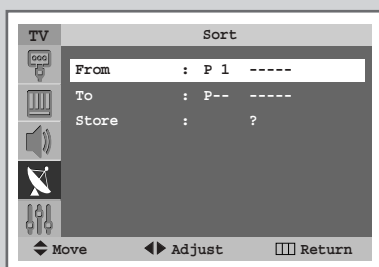
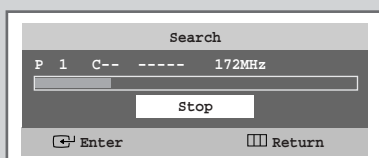
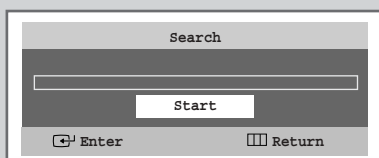
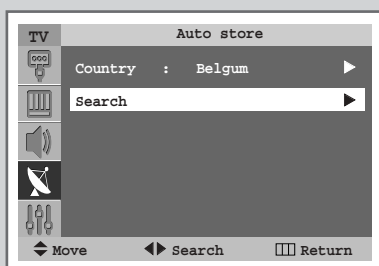
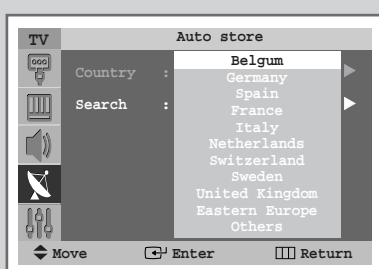
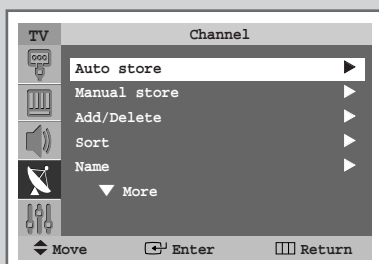

You can scan for the frequency ranges available to you (and availability depends on your country). Automatically allocated programme numbers may not correspond to actual or desired programme numbers. However you can sort numbers manually and clear any channels you do not wish to watch.

- 1 Press the **MENU** () button.
Result: The main menu is displayed.
- 2 Press the **▲** or **▼** button until the **Channel** is selected.
Result: The options available in the **Channel** group are displayed.
- 3 Press the **ENTER** () button.
Result: The **Auto Store** is selected.
- 4 Press the **ENTER** () button again.
Result: The **Auto Store** menu is displayed with **Country** option selected.
- 5 Press the **ENTER** () button again. Select your country by pressing the **▲** or **▼** button.
The countries are displayed in the following order:
Belgium - Germany - Spain - France - Italy - Netherlands - Switzerland - Sweden - United Kingdom - Eastern Europe - Others.
 - If you have selected the **Others** option but do not wish to scan the PAL frequency range, store the channels manually (see page 22).
- 6 Press the **ENTER** () button to confirm your choice
- 7 Press the **▲** or **▼** button until the **Search** is selected. Press the **◀** or **▶** button.
- 8 Press the **ENTER** () button to start the search.
Result: The search will end automatically. Channels are sorted and stored in an order which reflects their position in the frequency range, (with lowest first and highest last). The programme originally selected is then displayed.
 - To stop the search before it has finished or return to normal viewing, press the **MENU** () button.
- 9 When searching and storing are complete, the **Sort** menu is displayed.
 - ◆ To sort the stored channels into the desired numerical order, go to Step 6 of the "Sorting the Stored Channels" procedure on page 21.
 - ◆ To exit from the channel store function without sorting the channels, press the **MENU** () button repeatedly until the menus disappear.
- 10 When the channels have been stored, you can:
 - ◆ Sort them in the order required (see page 21)
 - ◆ Assign a name to the stored channels (refer to page 25)
 - ◆ Clear a channel (see page 24)
 - ◆ Fine-tune channel reception if necessary (see page 27)
 - ◆ Activate/deactivate the **LNA** (Low Noise Amplifier) feature (see page 28)
 - ◆ Activate/deactivate the **Digital NR** (Digital Noise Reduction) feature (see page 35)

Sorting the Stored Channels

This operation allows you to change the programme numbers of stored channels. This operation may be necessary after using auto store. You can delete the channels you do not want to keep.

- 1 Press the **MENU** (□□□) button.
Result: The main menu is displayed.
- 2 Press the ▲ or ▼ button until the **Channel** is selected.
Result: The options available in the **Channel** group are displayed.
- 3 Press the **ENTER** (↵) button.
- 4 Press the ▲ or ▼ button until the **sort** is selected. Press the **ENTER** (↵) button.
Result: The options available in the **sort** group are displayed with **From** is selected.
- 5 Select the channel number that you wish to change by pressing the ◀ or ▶ button repeatedly.
- 6 Press the ▲ or ▼ button until the **To** is selected. Select the new channel number which you wish to identify by pressing the ◀ or ▶ button repeatedly.
- 7 Press the ▲ or ▼ button until the **store** is selected. Select **OK** to confirm the exchange of channel numbers by pressing the **ENTER** (↵) button.
Result: The selected channel is exchanged with the one previously stored to the chosen number.
- 8 For all the channels to move to the required channel numbers, repeat steps 5 to 7 after selecting the **From** by pressing the ▲ or ▼ button.

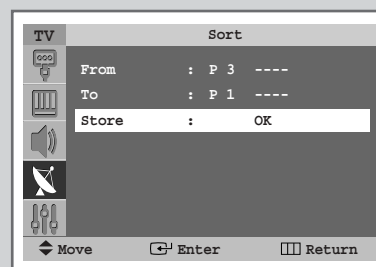
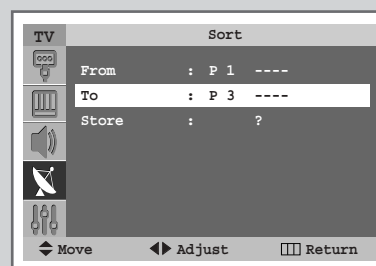
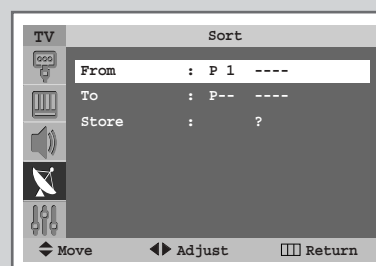
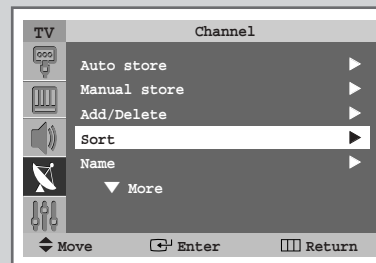

Storing Channels Manually

ENG

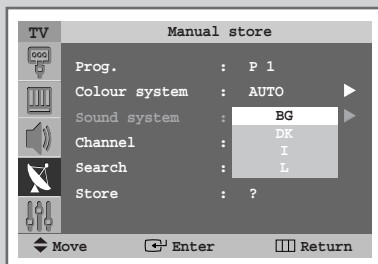
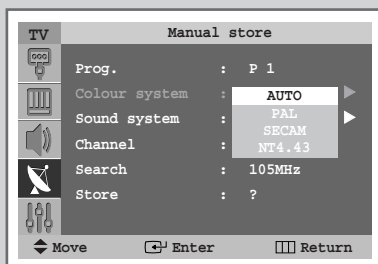
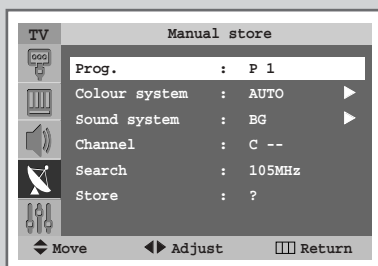
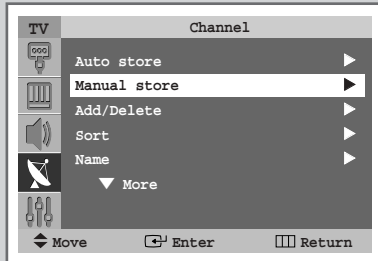

You can store the television channels, including those received via cable networks.

When storing channels manually, you can choose:

- ◆ Whether or not to store each of the channels found
- ◆ The programme number of each stored channel which you wish to identify

1 Press the **MENU** () button.

Result: The main menu is displayed.

2 Press the **▲** or **▼** button until the **Channel** is selected.

Result: The options available in the **Channel** group are displayed.

3 Press the **ENTER** () button.

4 Press the **▲** or **▼** button until the **Manual Store** is selected. Press the **ENTER** () button.

Result: The options available in the **Manual Store** group are displayed with **Prog.** is selected.

5 To assign a programme number to a channel, find the correct number by pressing the **◀** or **▶** button.

6 Press the **▲** or **▼** button until the **Colour System** is selected. Press the **ENTER** () button. Indicate the broadcasting standard required by pressing the **▲** or **▼** button.

Result: The colour standards are displayed in the following order.

AUTO - PAL - SECAM - NT4.43.

7 Press the **ENTER** () button to confirm.

8 Press the **▲** or **▼** button until the **Sound system** is selected. Press the **ENTER** () button. Select the sound standard required by pressing the **▲** or **▼** button.

Result: The sound standards are displayed in the following order:

BG - DK - I - L.

9 Press the **ENTER** () button to confirm.

Storing Channels Manually (continued)

ENG

- 10** If you know the number of the channel to be stored, see the following steps.
- ◆ Press the ▲ or ▼ button until the **Channel** is selected.
 - ◆ Press the ◀ or ▶ button.
 - ◆ Press the ▲ or ▼ button to select **C** (Air channel) or **S** (Cable channel).
 - ◆ Press the ◀ or ▶ button.
 - ◆ Press the ▲ or ▼ button to select the required number.

➤ If no sound or abnormal sound can be heard, re-select the sound standard required.

- 11** If you do not know the channel numbers, select **Search** by pressing the ▲ or ▼ button. Press the ◀ or ▶ button to start the search.

Result: The tuner scans the frequency range until the first channel or the channel that you selected is received on your screen.

- 12** To store the channel and associated programme number, select **store** by pressing the ▲ or ▼ button. Set to **OK** by pressing the **ENTER** (↵) button.

- 13** Repeat Steps **10** to **12** for each channel to be stored.



Channel mode

- ◆ **P** (Programme mode): When completing tuning, the broadcasting stations in your area have been assigned to position numbers from P00 to max P99. You can select a channel by entering the position number in this mode.
- ◆ **C** (Real channel mode): You can select a channel by entering the assigned number to each air broadcasting station in this mode.
- ◆ **S** (Cable channel mode): You can select a channel by entering the assigned number for each cable channel in this mode.

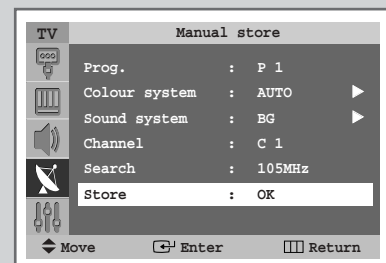
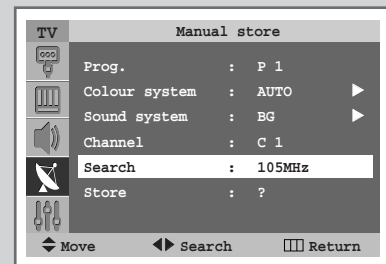
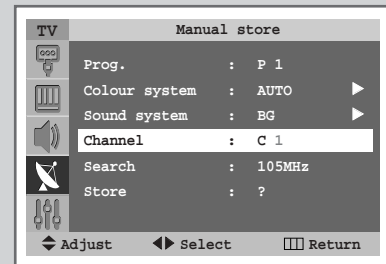
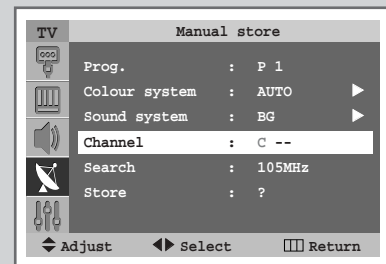



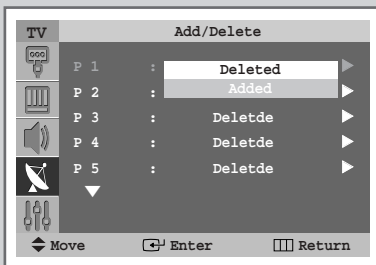
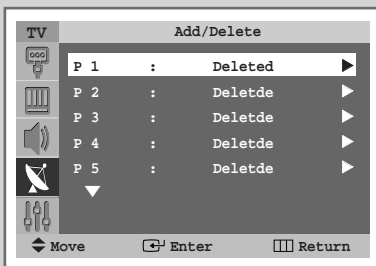
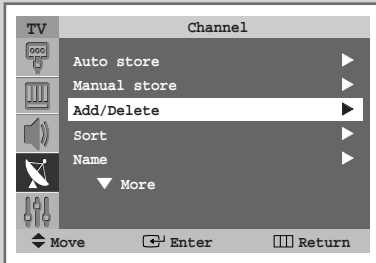

Skipping Unwanted Channels

ENG



You can exclude the channels you chosen from the channels you scanned. When you scan through the stored channels, those you have chosen to skip are not displayed. All of the channels that you do not specifically choose to skip are displayed during scanning.

- 1 Press the **MENU** () button.
Result: The main menu is displayed.
- 2 Press the **▲** or **▼** button until the **Channel1** is selected.
Result: The options available in the **Channel1** group are displayed.
- 3 Press the **ENTER** () button.
- 4 Press the **▲** or **▼** button until the **Add/Delete** is selected. Press the **ENTER** () button.
Result: The **Add/Delete** menu is displayed with the current channel selected.
- 5 To delete or add the required channel, select **Deleted** or **Added** by pressing the **▲** or **▼** button. Press the **ENTER** () button to confirm.
- 6 Repeat Step 5 for each channel to be erased or added.

Assigning Names to Channels

Channel names will be assigned automatically when channel information is broadcast. These names can be changed, allowing you to assign new names.

- 1 Press the **MENU** () button.
Result: The main menu is displayed.
- 2 Press the **▲** or **▼** button until the **Channel** is selected.
Result: The options available in the **Channel** group are displayed.
- 3 Press the **ENTER** () button.
- 4 Press the **▲** or **▼** button until the **Name** is selected. Press the **ENTER** () button.
Result: The **Name** menu is displayed with the current channel selected.
- 5 If necessary, select the channel to be assigned a new name by pressing the **▲** or **▼** button. Press the **ENTER** () button.
- 6 Press the **▲** or **▼** button to select a letter (A~Z), a number (0~9) or a symbol (-, space). Move on the previous or next letter by pressing the **◀** or **▶** button.
- 7 Repeat Steps 5 to 6 for each channel to be assigned to a new name.

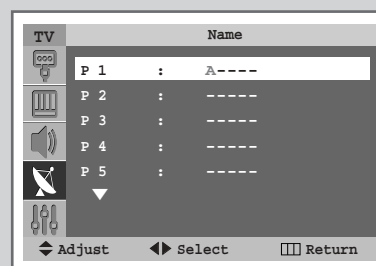
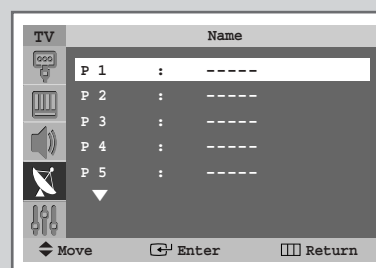
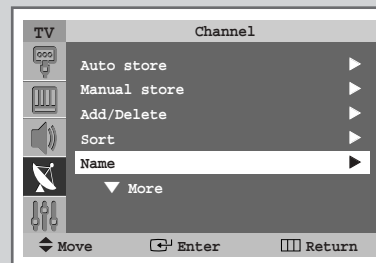

Locking the Channel

ENG

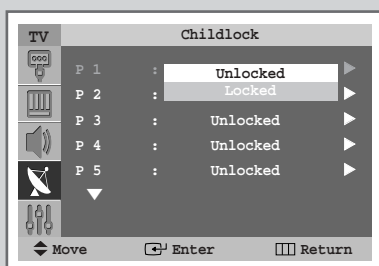
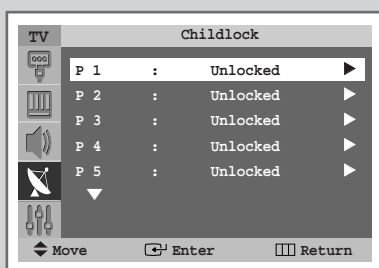
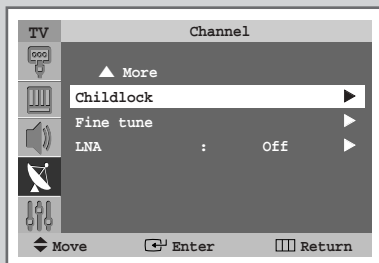

This feature allows you to lock the television so that it cannot be switched on via the front panel. It can, however, still be switched on via the remote control. Thus, by keeping the remote control away from unauthorised users, such as children, you can prevent them from watching unsuitable programmes.

- 1 Press the **MENU** () button.

Result: The main menu is displayed.

- 2 Press the **▲** or **▼** button until the **Channel** is selected.



Result: The options available in the **Channel** group are displayed.

- 3 Press the **ENTER** () button.

- 4 Press the **▲** or **▼** button until the **Childlock** is selected. Press the **ENTER** () button.

Result: The **Childlock** menu is displayed and the current channel is shown as selected.





- 5 Press the **▲** or **▼** button to select the channel to be locked.

- 6 Press the **ENTER** () button. To lock the channel, select **Locked** by pressing the **▲** or **▼** button (to unlock the channel, select **Unlocked**). Press the **ENTER** () button to confirm.

Fine Tuning Channel Reception

ENG

If the reception is clear, you do not have to fine tune the channel, as this is done automatically during the search and store operation. If the signal is weak or distorted, you may have to fine tune the channel manually.

- 1 Press the **MENU** () button.
Result: The main menu is displayed.
- 2 Press the **▲** or **▼** button until the **Channel** is selected.
Result: The options available in the **Channel** group are displayed.
- 3 Press the **ENTER** () button.
- 4 Press the **▲** or **▼** button until the **Fine tune** is selected.
Press the **ENTER** () button.
Result: The horizontal bar is displayed.
- 5 To obtain a sharp and clear picture and good sound quality, press the **◀** or **▶** button until you reach the setting.
- 6 To store the fine tuning setting in the TV's memory, press the **ENTER** () button.
- 7 To reset the fine tuning to 0, select **Reset** by pressing the **▲** or **▼** button then press the **ENTER** () button.

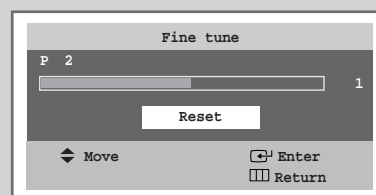
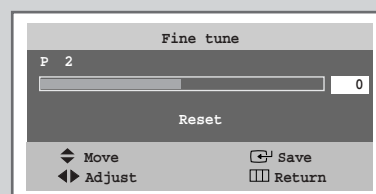
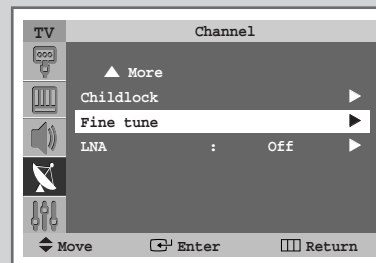

Using the LNA (Low Noise Amplifier) Feature

ENG

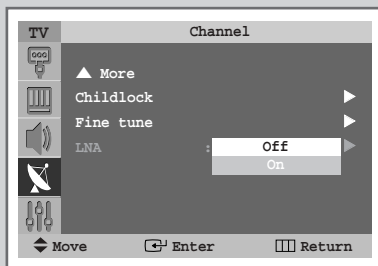
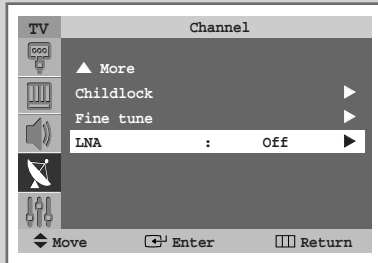

This feature is very useful in the situation that the TV is used in a weak signal, and amplifies the TV signal in the weak signal area, but not noise.





This feature is working only in a weak signal condition, and that is memorized on relevant channel's additional information.

- 1 Press the **MENU** () button.
Result: The main menu is displayed.
- 2 Press the **▲** or **▼** button until the **Channel** is selected.
Result: The options available in the **Channel** group are displayed.
- 3 Press the **ENTER** () button.
- 4 Press the **▲** or **▼** button until the **LNA** is selected. Press the **ENTER** () button.
- 5 Select **Off** or **On** by pressing the **▲** or **▼** button. Press the **ENTER** () button to confirm.

Changing the Picture Standard

ENG

You can select the type of picture which best corresponds to your viewing requirements.

- 1 Press the **MENU** () button.
Result: The main menu is displayed.
- 2 Press the **▲** or **▼** button until the **Picture** is selected.
Result: The options available in the **Picture** group are displayed.
- 3 Press the **ENTER** () button.
Result: The **Mode** is selected.
- 4 Press the **ENTER** () button again.
Result: The options available are listed.
- 5 Select the required option by pressing the **▲** or **▼** button.
Result: The following modes are available:
Dynamic – Standard – Movie – Custom
- 6 Press the **ENTER** () button to confirm.

➤ You can also set these options simply by pressing the **P.MODE** ( : Picture Mode) button.

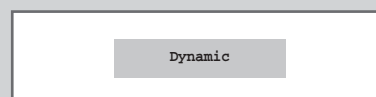
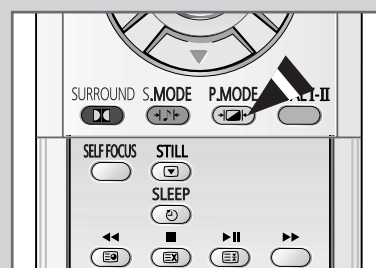
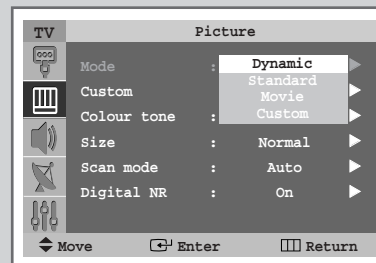

Customizing the Picture Settings

ENG

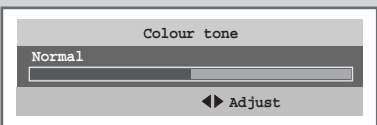
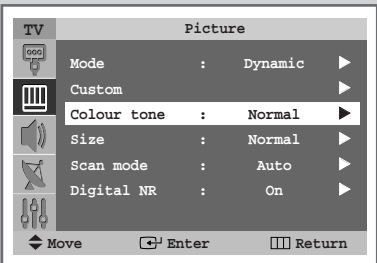
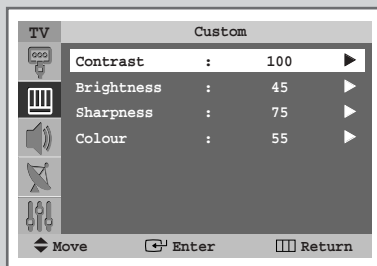
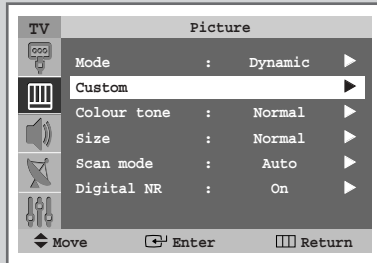



Your television has several settings options that allow you to control picture quality.



- 1 Press the **MENU** () button.
Result: The main menu is displayed.

- 2 Press the **▲** or **▼** button until the **Picture** is selected.
Result: The options available in the **Picture** group are displayed.

- 3 Press the **ENTER** () button.

- 4 Press the **▲** or **▼** button until the **Custom** is selected. Press the **ENTER** () button.
Result: The **Custom** menu is displayed.

- 5 Select the option (**Contrast**, **Brightness**, **Sharpness**, **Colour** or **Tint-NTSC** only) to be adjusted by pressing the **▲** or **▼** button. Press the **ENTER** () button.
Result: The horizontal bar is displayed. Move the horizontal bar's cursor left or right by pressing the **◀** or **▶** button.





- 6 Press the **MENU** () button to return the **Picture** menu. Press the **▲** or **▼** button until the **Colour tone** is selected. Press the **ENTER** () button.

- 7 Select the required colour tone (**Warm1** ~ **Warm10**, **Normal**, **Cool1** ~ **Cool10**) by pressing the **◀** or **▶** button.

Selecting the Picture Size (4:3 Model)

ENG

You can select the picture size which best corresponds to your viewing requirements.

- 1 Press the **MENU** () button.
Result: The main menu is displayed.
 - 2 Press the **▲** or **▼** button until the **Picture** is selected.
Result: The options available in the **Picture** group are displayed.
 - 3 Press the **ENTER** () button.
 - 4 Press the **▲** or **▼** button until the **size** is selected. Press the **ENTER** () button.
Result: The **size** menu is displayed.
 - 5 Select the required mode by pressing the **▲** or **▼** button. Press the **ENTER** () button.
Result: The following modes are available:
Normal – Zoom1 – Zoom2 – Cinema
 - Lifting is available in the **Zoom1** or **Zoom2** mode by pressing the **▲** or **▼** button.
- You can select these options by simply pressing the **P.SIZE** () button on the remote control.

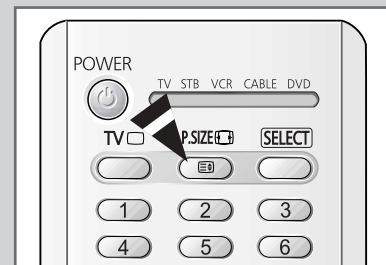
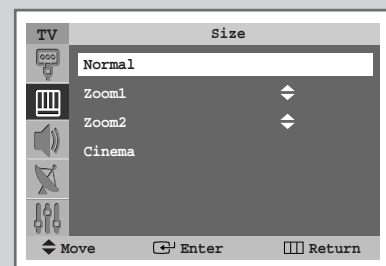
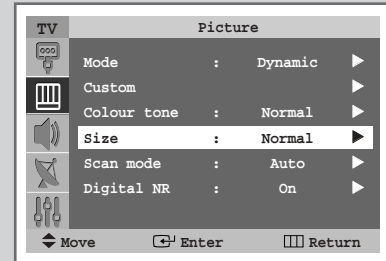

4:3 Signal

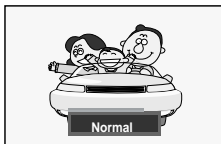

Normal

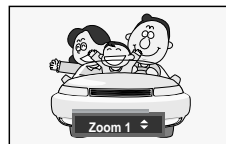

Zoom 1



Zoom 2

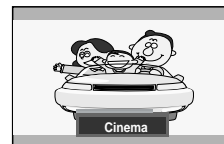

Cinema

16:9 Signal



Normal

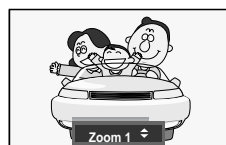

Zoom 1

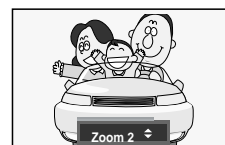

Zoom 2

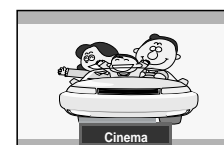

Cinema

Selecting the Picture Size (Wide Model)

ENG

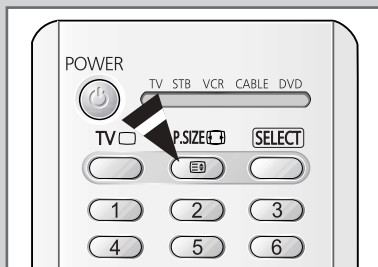
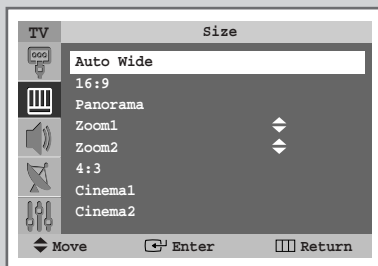
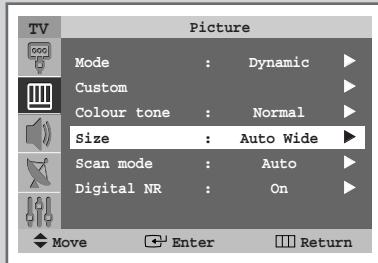



You can select the picture size which best corresponds to your viewing requirements.

- 1 Press the **MENU** () button.
Result: The main menu is displayed.

- 2 Press the **▲** or **▼** button until the **Picture** is selected.
Result: The options available in the **Picture** group are displayed.

- 3 Press the **ENTER** () button.

- 4 Press the **▲** or **▼** button until the **size** is selected. Press the **ENTER** () button.
Result: The **size** menu is displayed.

- 5 Select the required mode by pressing the **▲** or **▼** button. Press the **ENTER** () button.
Result: The following modes are available:
Auto wide – 16:9 – panorama – Zoom1 – Zoom2
– 4:3 – Cinema1 – Cinema2

➤ Lifting is available in the **Zoom1** or **Zoom2** mode by pressing the **▲** or **▼** button.

➤ You can select these options by simply pressing the **P.SIZE** () button on the remote control.

Selecting the Picture Size (Wide Model) (continued)

ENG

4:3 Signal

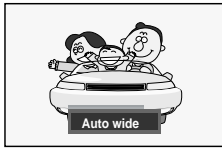

Auto wide



16:9

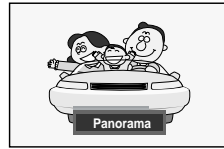

Panorama

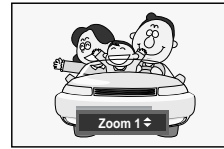

Zoom 1

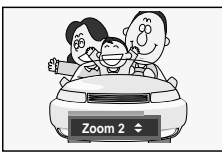

Zoom 2



4:3

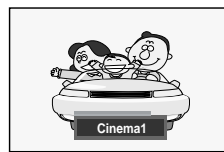

Cinema1

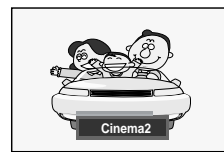

Cinema2

16:9 Signal

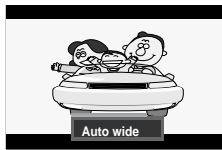

Auto wide



16:9



Panorama

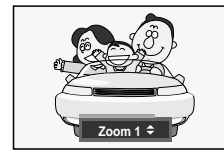

Zoom 1

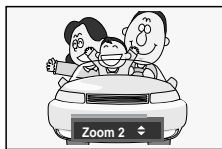

Zoom 2



4:3

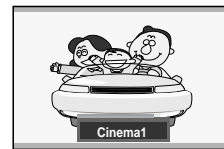

Cinema1

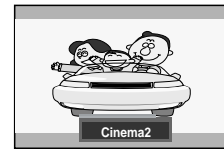



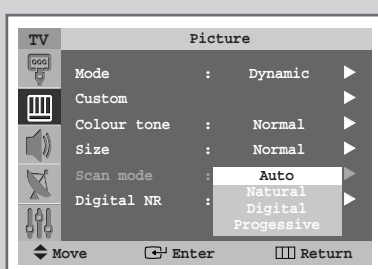
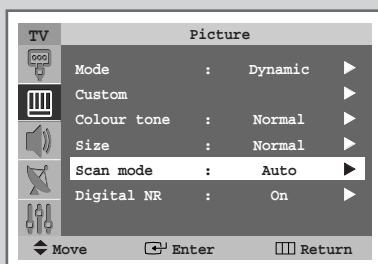

Cinema2

Selecting the Scan Mode

ENG







*You will normally find that scan mode is best set to **Natural** to reduce any slight picture flicker. However, it is possible that some occasional broadcasts (NTSC-M) may benefit by changing the scan mode.*

- 1 Press the **MENU** () button.
Result: The main menu is displayed.
- 2 Press the **▲** or **▼** button until the **Picture** is selected.
Result: The options available in the **Picture** group are displayed.
- 3 Press the **ENTER** () button.
- 4 Press the **▲** or **▼** button until the **Scan Mode** is selected. Press the **ENTER** () button.
- 5 Select the required option by pressing the **▲** or **▼** button.
Result: The following modes are available:
Auto – Natural – Digital – Progressive
- 6 Press the **ENTER** () button to confirm.

Using the Digital NR (Digital Noise Reduction) Feature

ENG

If the signal received by your television is weak, you can activate this feature to help reduce any static and ghosting that may appear on the screen.

- 1 Press the **MENU** () button.
Result: The main menu is displayed.
- 2 Press the **▲** or **▼** button until the **Picture** is selected.
Result: The options available in the **Picture** group are displayed.
- 3 Press the **ENTER** () button.
- 4 Press the **▲** or **▼** button until the **Digital NR** is selected. Press the **ENTER** () button.
- 5 Select **Off** or **On** by pressing the **▲** or **▼** button. Press the **ENTER** () button to confirm.

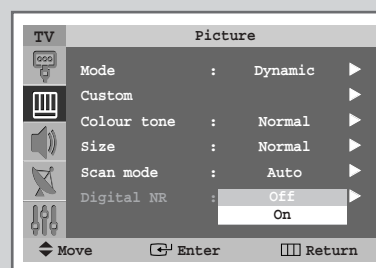
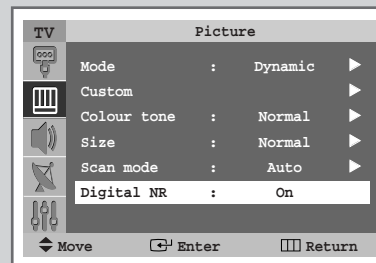

Setting the Blue Screen Mode

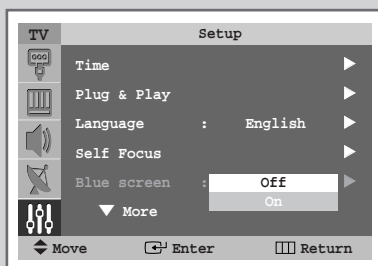

If no signal is being received or the signal is very weak, a blue screen automatically replaces the noisy picture background. If you wish to continue viewing the poor picture, you must set the **Blue screen mode to off**.

- 1 Press the **MENU** () button.
Result: The main menu is displayed.
- 2 Press the **▲** or **▼** button until the **Setup** is selected.
Result: The options available in the **Setup** group are displayed.
- 3 Press the **ENTER** () button.
- 4 Press the **▲** or **▼** button until the **Blue screen** is selected. Press the **ENTER** () button.
- 5 Select **Off** or **On** by pressing the **▲** or **▼** button. Press the **ENTER** () button to confirm.

Freezing the Current Picture

You can freeze the picture when watching a television programme simply by pressing the "**STILL** ()" button. To return to normal viewing, press it again.



Changing the Sound Standard

ENG

You can select the type of special sound effect to be used when watching a given broadcast.

- 1 Press the **MENU** () button.
Result: The main menu is displayed.
- 2 Press the **▲** or **▼** button until the **Sound** is selected.
Result: The options available in the **Sound** group are displayed.
- 3 Press the **ENTER** () button.
Result: The **Mode** is selected.
- 4 Press the **ENTER** () button again.
- 5 Select the required option by pressing the **▲** or **▼** button.
Result: The following modes are available:
Standard - Music - Movie - Speech - Custom.
- 6 Press the **ENTER** () button to confirm.

➤ You can also set these options simply by pressing the **S.MODE** (: Sound Mode) button.

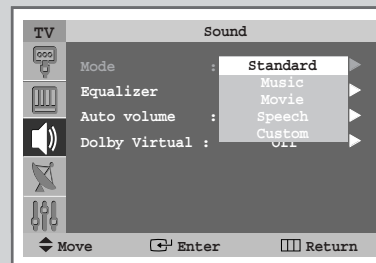

Adjusting the Sound Settings

ENG

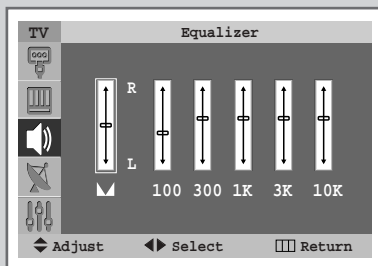
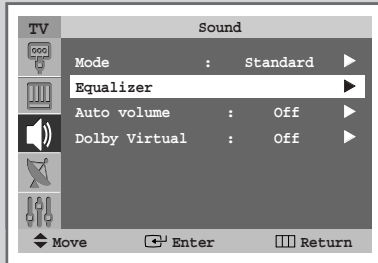

The sound settings can be adjusted to suit your personal preferences.

- 1 Press the **MENU** () button.
Result: The main menu is displayed.
- 2 Press the **▲** or **▼** button until the **Sound** is selected.
Result: The options available in the **Sound** group are displayed.
- 3 Press the **ENTER** () button.
- 4 Press the **▲** or **▼** button until the **Equalizer** is selected.
Press the **ENTER** () button.
Result: The **Equalizer** menu is displayed with the current option.
- 5 Select the option to be adjusted by pressing the **◀** or **▶** button.
Press the **▲** or **▼** button to reach the required setting.

➤ If you make any changes to these settings, the sound standard is automatically switched to **Custom**.

Extra Sound Settings

ENG

◆ *Auto volume*

Each broadcasting station has its own signal conditions, and so it is not easy for you to adjust the volume every time the channel is changed. This feature lets you automatically adjust the volume of the desired channel by lowering the sound output when the modulation signal is high or by raising the sound output when the modulation signal is low.

◆ *Dolby Virtual*

This feature converts a monaural sound signal into two identical left and right channels. Once the **Dolby Virtual** is set to **Off** or **On**, the setting applies to the sound effects such as **Standard**, **Music**, **Movie** and **Speech**.

- 1 Press the **MENU** () button.
Result: The main menu is displayed.
- 2 Press the **▲** or **▼** button until the **Sound** is selected.
Result: The options available in the **Sound** group are displayed.
- 3 Press the **ENTER** () button.
- 4 Select the required option (**Auto volume** or **Dolby Virtual**) by pressing the **▲** or **▼** button.
- 5 Press the **ENTER** () button.
- 6 To activate each feature, select **On** by pressing the **▲** or **▼** button. Press the **ENTER** () button.

- Manufactured under license from Dolby Laboratories. "Dolby" and the double-D symbol  are trademarks of Dolby Laboratories.

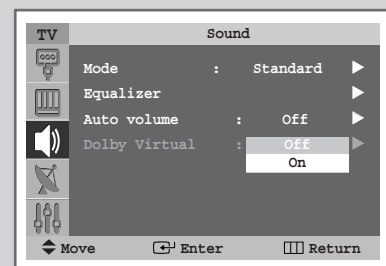
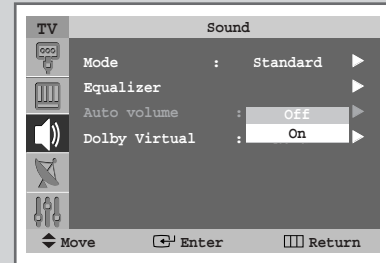

Setting the Melody Sound

ENG

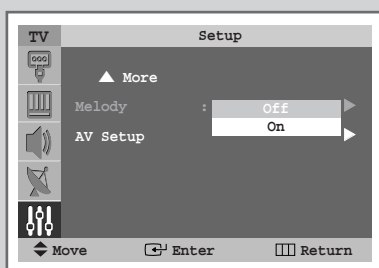
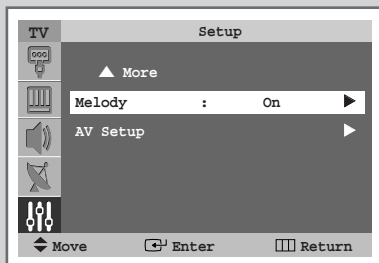

You can hear clear melody sound when the television is powered on or off.

- 1 Press the **MENU** () button.
Result: The main menu is displayed.
- 2 Press the **▲** or **▼** button until the **Setup** is selected.
Result: The options available in the **Setup** group are displayed.
- 3 Press the **ENTER** () button.
- 4 Press the **▲** or **▼** button until the **Melody** is selected. Press the **ENTER** () button.
- 5 Select the required option (**Off** or **On**) by pressing the **▲** or **▼** button.
- 6 Press the **ENTER** () button to confirm.

Selecting the Sound Mode (depending on the model)

ENG

The "DUAL I-II" button displays/controls the processing and output of the audio signal. When power is switched on, the mode is automatically preset to either "Dual-I " or "Stereo", depending on the current transmission.

	Type of broadcast	On-screen indication
NICAM Stereo	Regular broadcast (Standard audio)	Mono (Normal use)
	Regular + NICAM Mono	Mono ↔ Mono NICAM (Normal)
	NICAM Stereo	Stereo ↔ Mono NICAM (Normal)
	NICAM Dual-I/II	Dual-I → Dual-II → Mono NICAM NICAM (Normal) ↑ ↓
A2 Stereo	Regular broadcast (Standard audio)	Mono (Normal use)
	Bilingual or Dual-I/II	DUAL-I ↔ DUAL-II
	Stereo	Stereo ↔ Mono (Forced mono)

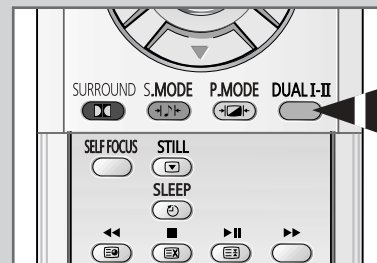

-
- ◆ If the receiving conditions deteriorate, listening will be easier if the mode is set to the **Mono**.
 - ◆ If the stereo signal is weak and an automatic switching occurs, then switch to the **Mono**.
 - ◆ When receiving a mono sound in the AV mode, connect to the "AUDIO-L" input connector on the panel (front or side). If the mono sound comes out only from left speaker, press the **DUAL I-II** button.

Setting and Displaying the Current Time

ENG

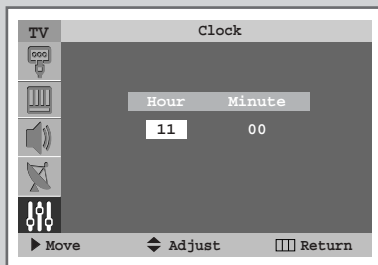
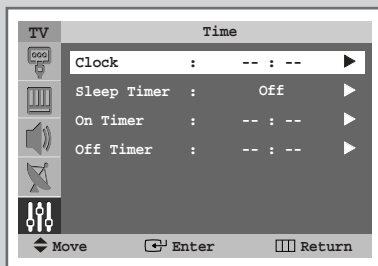
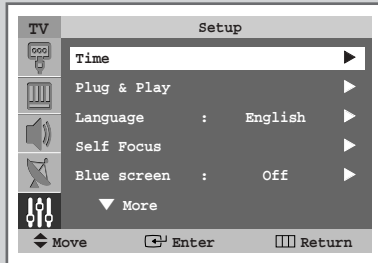

You can set the television's clock so that the current time is displayed by pressing the "INFO (I)" button. You must also set the time if you wish to use the automatic on or off timers.

➤ When pressing the "I" button (On/Off) on the front of the television, the clock setting will be reset.

1 Press the **MENU** (☰) button.

Result: The main menu is displayed.

2 Press the **▲** or **▼** button until the **Setup** is selected.

Result: The options available in the **Setup** group are displayed.

3 Press the **ENTER** (↵) button.

4 Press the **▲** or **▼** button until the **Time** is selected. Press the **ENTER** (↵) button.

Result: The options available in the **Time** group are displayed with **Clock** is selected.

5 Press the **ENTER** (↵) button.

6 Press the **◀** or **▶** button to move to the **Hour** or **Minute**. Set the hour or minute by pressing the **▲** or **▼** button.

Setting the Sleep Timer

You can select a time period of between 30 and 180 minutes after which the television automatically switches to Standby mode.

- 1 Press the **MENU** () button.
Result: The main menu is displayed.
- 2 Press the **▲** or **▼** button until the **Setup** is selected.
Result: The options available in the **Setup** group are displayed.
- 3 Press the **ENTER** () button.
- 4 Press the **▲** or **▼** button until the **Time** is selected. Press the **ENTER** () button.
Result: The options available in the **Time** group are displayed.
- 5 Press the **▲** or **▼** button until the **Sleep Timer** is selected. Press the **ENTER** () button.
- 6 Select the preset time interval (**Off**, 30, 60, 90, 120, 150, 180) for staying on by pressing the **▲** or **▼** button. Press the **ENTER** () button to confirm.

- ◆ You can also set these options simply by pressing the **SLEEP** () button.
- ◆ If the sleep timer is not yet set, **OFF** is displayed. If the sleep timer is already set, the remaining time before which the television switches to Standby mode is displayed.

ENG

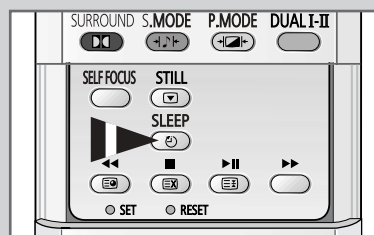
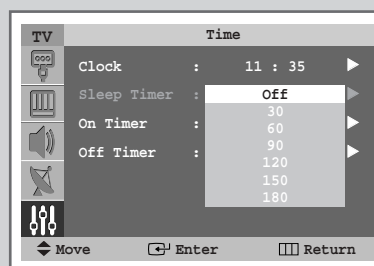
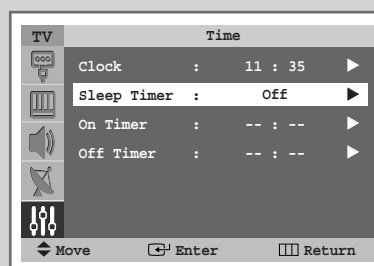
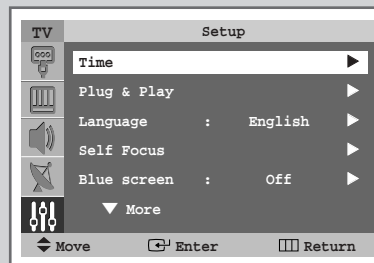

Off

Switching the Television On and Off Automatically

ENG

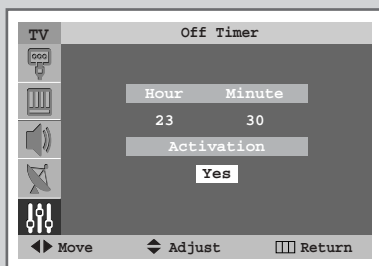
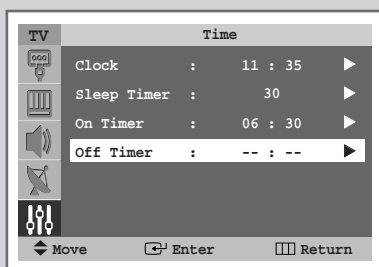
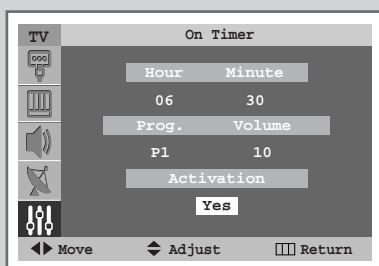
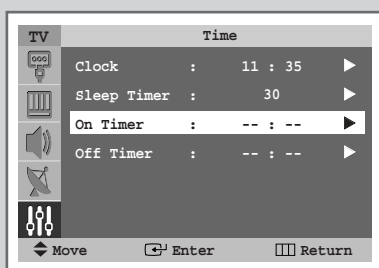

You can set the On/Off timers so that the television will:

- ◆ Switch on automatically and tune to the channel of your choice at the time you select
- ◆ Switch off automatically at the time you select

➤ The first step is to set the television's clock (refer to "Setting the Current Time" on page 42). If you have not yet set the clock, the message **Set the clock first** is displayed.

- 1 Press the **MENU** () button.
Result: The main menu is displayed.

- 2 Press the **▲** or **▼** button until the **Setup** is selected.
Result: The options available in the **Setup** group are displayed.

- 3 Press the **ENTER** () button.

- 4 Press the **▲** or **▼** button until the **Time** is selected. Press the **ENTER** () button.
Result: The options available in the **Time** group are displayed.

- 5 Press the **▲** or **▼** button until the **On Timer** is selected. Press the **ENTER** () button.
Result: The options available in the **On Timer** group are displayed.

- 6 Select the **Hour**, **Minute**, **Prog.** (programme number) or **Volume**. Press the **◀** or **▶** button to set these by pressing the **▲** or **▼** button.

- 7 To activate the **On Timer** with the settings satisfied, select **Activation** to by pressing the **◀** or **▶** button, then select **Yes** by pressing the **▲** or **▼** button.

- 8 Press the **MENU** () button.
Result: The options available in the **Time** group are displayed again.

- 9 Press the **▲** or **▼** button until the **Off Timer** is selected. Press the **ENTER** () button.
Result: The **Off Timer** menu is displayed.

- 10 Set the **Off Timer** as methods for **On Timer** setting.

➤ Absent Power Off

When you set the timer "On", your television will eventually be turned off, if you do not operate any controls during the 3 hours after the TV is turned on by timer. This function is available in only the timer "On" mode and will prevent a leakage accident or overheating, caused by your TV left on for a long time due to the timer "On" (when you are away on holiday, for example).

Viewing an External Signal Source



ENG

Use the remote control to switch between viewing signals from connected equipment, such as VCR, DVD, Set-Top Box and the TV source (broadcast or cable)

- 1 Press the **MENU** () button.
Result: The options available in the **Input** group are displayed.

- 2 Press the **ENTER** () button.
Result: The **source List** is selected.

- 3 Press the **ENTER** () button again.

- 4 Press the **▲** or **▼** button to select signal source, then press the **ENTER** () button.
 - ◆ When you connect equipment to the TV, you can choose between the following sets of jacks : **Ext.1**, **Ext.2**, **Ext.3** or **Component** on the TV's rear panel, and **AV** or **S-video** on the TV's side panel.
 - ◆ You can select these options simply by pressing the **SOURCE** () button.

- 5 Press the **MENU** () button.
Result: The options available in the **Input** group are displayed again.

- 6 Press the **▲** or **▼** button until the **Edit Name** is selected. Press the **ENTER** () button.

- 7 Press the **▲** or **▼** button to select the external source to be edited. Press the **ENTER** () button.
Result: The device names available are listed.
 VCR - DVD - Cable STB - HD STB - Sat. STB -
 AV Recv. - DVD Recv. - Game - Camcorder -
 DVD Combo - DHR (DVD HDD Recorder) - PC.

- 8 Select the required device by pressing the **▲** or **▼** button. Press the **ENTER** () button to confirm.

- If you change the external source while viewing, pictures might take a short period of time to be switched.

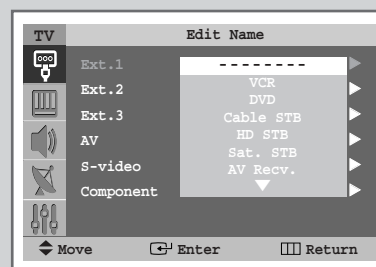
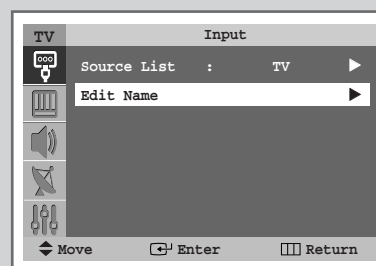
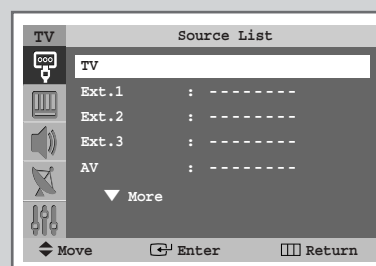
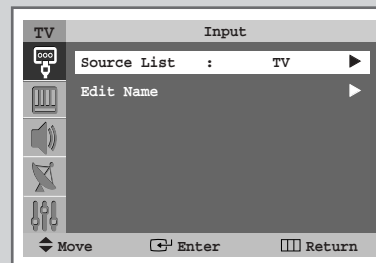

Teletext Feature

ENG

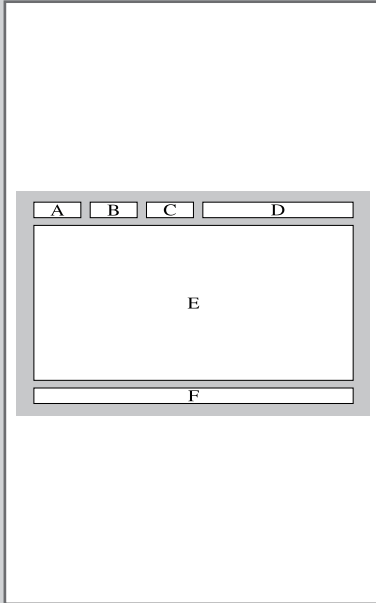

Most television channels provide written information services via teletext. Information provided includes:

- ◆ *Television programme times*
- ◆ *News bulletins and weather forecasts*
- ◆ *Sports results*
- ◆ *Travel information*

This information is divided into numbered pages (see diagram).

Part	Contents
A	Selected page number.
B	Broadcasting channel identity.
C	Current page number or search indications.
D	Date and time.
E	Text.
F	Status information. FASTEXT information.

- Teletext information is often divided between several pages displayed in sequence, which can be accessed by:
- ◆ Entering the page number
 - ◆ Selecting a title in a list
 - ◆ Selecting a coloured heading (FASTEXT system)

Displaying the Teletext Information

ENG

You can display Teletext information at any time on your television.

- ✎ For Teletext information to be displayed correctly, channel reception must be stable; otherwise:
- ◆ Information may be missing
 - ◆ Some pages may not be displayed

- 1 Select the channel providing the Teletext service using the **P** or **CH** button.
- 2 Press the **TTX/MIX** (📺📄) button to activate the teletext mode.
Result: The contents page is displayed. It can be redisplayed at any time by pressing the **INDEX** (📄) button.
- 3 Press the **TTX/MIX** (📺📄) button again.
Result: The screen will be split into two. This Double Teletext feature lets you view the actual broadcast and teletext information separately on the screen.
- 4 If you wish to display the actual broadcast at the same time as the teletext page, press the **TTX/MIX** (📺📄) button again.
- 5 Press the **TV** (📺) button again to exit from the teletext display.

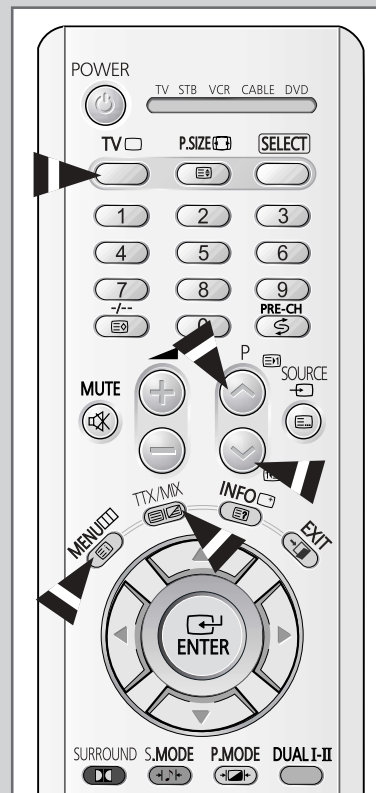

Selecting Display Options

ENG

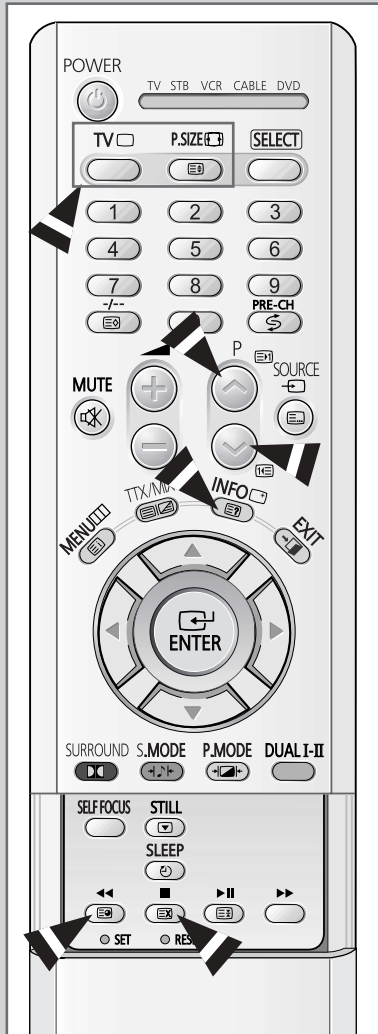

When you have displayed a Teletext page, you can select various options to suit your requirements.





To display...	Press the...
◆ Hidden text (answers to quiz games, for example)	[REVEAL] (reveal)
◆ The normal screen	[REVEAL] (reveal) again
◆ A secondary page	[SUB-PAGE] (sub-page)
◆ The broadcast when searching for a page	[CANCEL] (cancel)
◆ The next page	[PAGE UP] (page up)
◆ The previous page	[PAGE DOWN] (page down)
◆ Double-size letters in the: <ul style="list-style-type: none"> • Upper half of the screen • Lower half of the screen 	[SIZE] (size) <ul style="list-style-type: none"> • Once • Twice
◆ Normal screen	• Three times

➤ To return to the normal display after using the reveal or size feature, press the **TV** (□) button.

Selecting a Teletext Page

ENG

You can enter the page number directly by pressing the numeric buttons on the remote control.

- 1 Enter the three-digit page number given in the content by pressing the corresponding numeric buttons.
Result: The current page counter is incremented and the page is then displayed. If the selected page is linked with several secondary pages, the secondary pages are displayed in sequence. To freeze the display on a given page, press the  (hold). Press it again to resume.
- 2 If the FASTEXT system is used by the broadcasting company, the different topics covered on a Teletext page are colour-coded and can be selected by pressing the coloured buttons on the remote control.
Press the coloured button corresponding to the topic that you wish to select; the available topics are given on the status line.
Result: The page is displayed with other coloured information that can be selected in the same way.
- 3 To display the previous or next page, press the corresponding coloured button.
- 4 To display the subpage, see the following steps.
 - ◆ Press the  (sub-page) button.
Result: The available subpages appear.
 - ◆ Select the required sub-page. Sub-pages can be scrolled by pressing the  or  button.
- 5 When you have finished, press the TV () button to return to your normal broadcast.

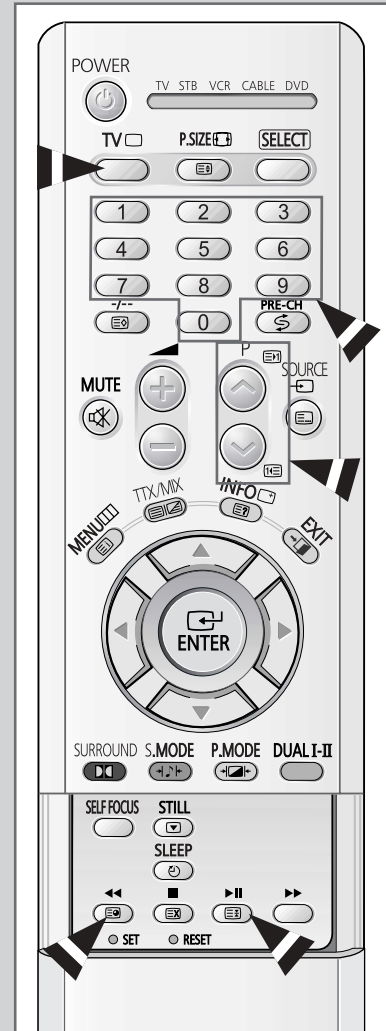

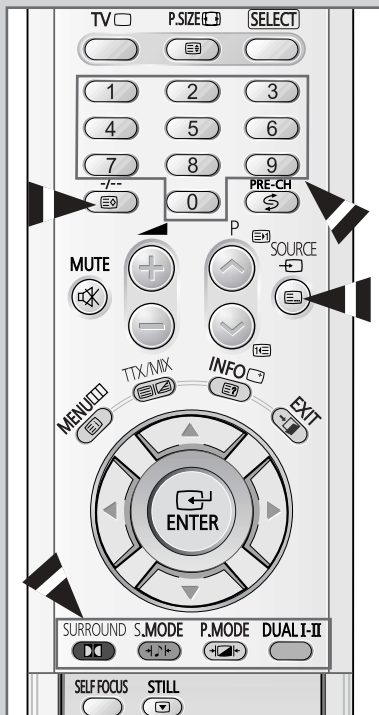

Storing Teletext Pages (depending on the model)

ENG



You can store up to four teletext pages to display them later at leisure.

- 1 Select the LIST mode using the  button.
Result: Four 3-digit numbers are displayed in different colours.
➤ The  button is used to switch between the LIST and FLOF modes.
- 2 Press the coloured button corresponding to the page that will be replaced.
- 3 Enter the new page number using the numeric buttons.
- 4 Repeat steps 2 and 3 for each page to be stored, using a different coloured button each time.
- 5 Press the  (store) button until the corresponding blocks blink.

Connecting to the External Input/Outputs

ENG

- **EXT-1** is used for the equipment with an RGB output, such as video game devices or video disc players.

Rear of the TV

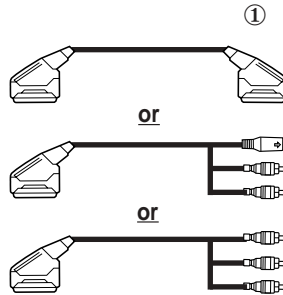
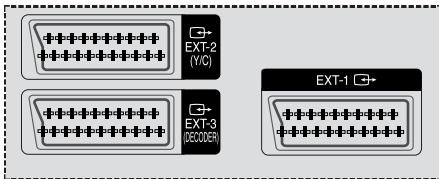

- ① This end can be fitted with:
 - ◆ A SCART connector
 - ◆ An S-Video connector and two audio RCA connectors (L+R); **EXT- 2**
 - ◆ Three RCA connectors (VIDEO + AUDIO-L and R)
- ② If you have a second VCR and wish to copy cassette tape, connect the source VCR to **EXT-1** and the target VCR to **EXT-2** so that you can redirect the signal from **EXT-1** to **EXT-2**.
- ③ If you have a decoder, connect the decoder to the VCR and the VCR to the television.
- ④ When you wish to record a programme, connect the receiver to **EXT-1** and the VCR to **EXT-2** so that you can redirect the signal from **EXT-1** to **EXT-2**.

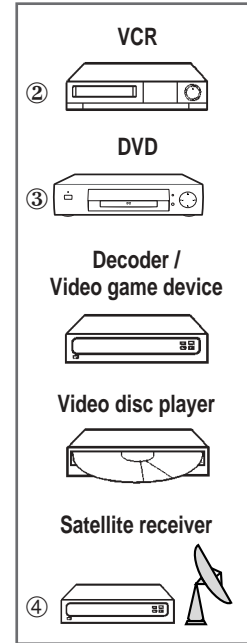

- ☞ Whenever you connect an audio or video system to your television, ensure that all elements are switched off.

Refer to the documentation supplied with your equipment for detailed connection instructions and associated safety precautions.

Connecting to the Audio Output

ENG

- The RCA (**AUDIO-L** and **R**) connectors are used for equipment, such as an audio system (to take full advantage of the Surround sound effect).

Rear of the TV



Audio system

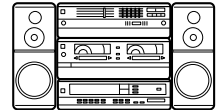

Connecting to the RCA Input

ENG

- The RCA (**VIDEO + AUDIO-L and R**) connectors are used for the equipment, such as camcorders, video disc players, and some video game devices.

Side of the TV
(depending on the model)

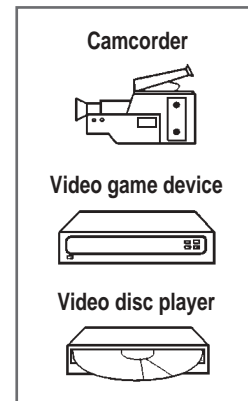

Connecting to the S-Video Input

ENG

- The **S-VIDEO** (or **S-VIDEO INPUT**) and RCA (**AUDIO-L** and **R**) connectors are used for equipment with an S-Video output, such as a camcorder or VCR.

Side of the TV
(depending on the model)

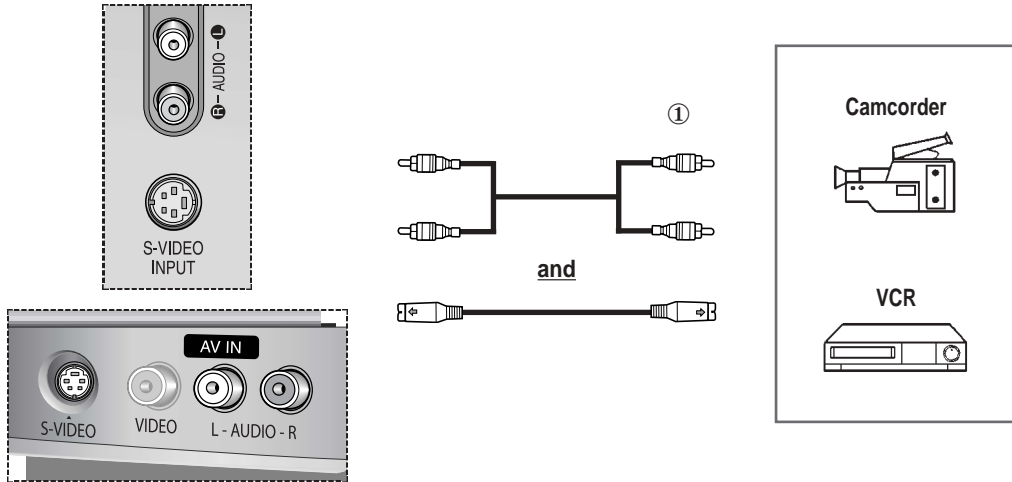

- ① To play pictures and sound, both the **S-VIDEO** (or **S-VIDEO INPUT**) and RCA connectors must be used.

Connecting to the Component Input

ENG

Rear of the TV

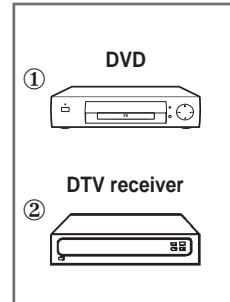
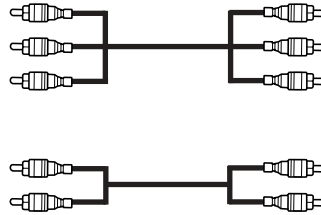
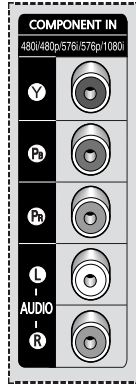

- The **COMPONENT IN** connectors are used for equipment with a DVD or DTV receiver output. (480i, 480p, 576i, 576p, 1080i)

Redirecting an Input to the External Output

ENG

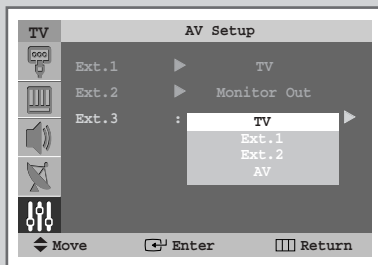
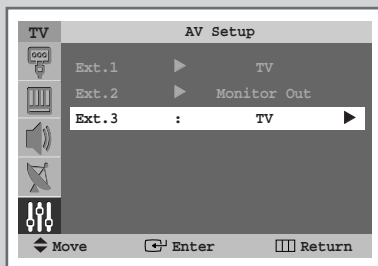
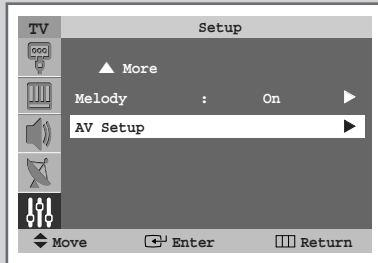

Your television enables you to choose which audio/video signals are output to the external connector.

- 1 Press the **MENU** () button.
Result: The main menu is displayed.
- 2 Press the **▲** or **▼** button until the **Setup** is selected.
Result: The options available in the **Setup** group are displayed.
- 3 Press the **ENTER** () button.
- 4 Press the **▲** or **▼** button to select **AV Setup**. Press the **ENTER** () button.
Result: The **AV Setup** menu is displayed with the **Ext.3** is selected.
- 5 Press the **ENTER** () button. Select the source to be directed to the output of **Ext.3** by pressing the **▲** or **▼** button.
 - **Ext.1** : Default (**TV**)
 - Ext.2** : Default (**Monitor Out**)
 - Ext.3** : Variable (**TV**, **Ext.1**, **Ext.2** or **AV**)
- 6 Press the **ENTER** () button to confirm your choice.

Programming the Remote Control for Other Components

ENG

Your TV comes equipped with a universal remote control.

In addition to controlling the TV, the universal remote control can also operate a Set-Top Box, VCR, Cable box and DVD (even if your VCR, Cable box and DVD are made by manufacturers other than Samsung).

- The remote control might not be compatible with all VCRs, DVD players and Cable boxes.

- 1 Turn off your VCR (Cable box or DVD).
- 2 Press the **SELECT** button to switch the remote control to the **VCR (CABLE or DVD)** mode.
 - The remote control has five modes : **TV**, **STB**, **VCR**, **CABLE** and **DVD**
- 3 Press the **SET** button.
- 4 Enter 3 digits of the VCR (Cable box or DVD) code listed on next page for your VCR (Cable box or DVD).

Example: To enter the code "6", press 0, 0, and 6.
To enter the code "76", press 0, 7, and 6.
- 5 Press the **POWER** (⏻) button. Your VCR (Cable box or DVD) should turn on. If it turns on, your remote control is now set correctly.
 - If it does not turn on, repeat steps above, but try one of the other codes listed for the brand of particular yours.
- 6 Once your remote control is set up, press the **SELECT** button any time you want to use the remote control to operate VCR (Cable box or DVD).
 - ◆ When your remote control is in the **STB**, **VCR**, **CABLE** and **DVD** mode, the volume buttons still control your television's volume.
 - ◆ When your remote control is in the **TV** mode, the VCR or DVD control buttons (rewind, stop, play/pause and fast forward) still operate your VCR or DVD.

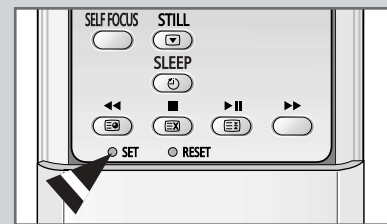
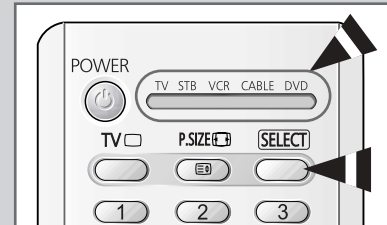

Programming the Remote Control for Other Components

ENG

VCR Remote Control Codes

000	Samsung	018	Candle, Citizen, Emerson, LG(Goldstar), Radio Shack, Realistic, Sears, TOSHIBA, Technika, Television	036	Electrohome, Emerson, Radio Shack, Realistic, Sharp	059	Pioneer
001	LG(Goldstar)			037	RCA	060	JC Penny
002		Daewoo	019	Broksonic, Emerson	038	Magnavox, Marantz, Philco, Philips, Sylvania	061
003	021		Craig, Fisher, Radio Shack, Realistic, Sanyo, Sears	039	JC Penny, JCL, Kenwood, Marantz, NEC, Tatung, Teac	062	Canon, Curtis Mathes, General Electric, JC Penny, Magnavox, Panasonic, Philco, Radio Shack, Realistic, Sylvania
004	022		Audio Dynamics, Candle, Citizen, Daewoo, Emerson, Samsung, Scott, Toshiba	040	Logik, Multitech, Shintom	063	RCA
005				041	General Electric, Multitech, Samsung	064	Shintom
006	023		Colorlyme, Curtis Mathes, DB, LG(Goldstar), Harman Kardon, JC Penny, JCL, Kenwood, Marantz, NEC	042	Pioneer	065	Magnavox, Philco, Sylvania
007		043		Emerson	066	Emerson	
008	024	Aiwa, Curtis Mathes, Dynatech, Emerson, Funai, Hitachi, Lloyd, LXI, MTC, Multitech, Radio Shack, Realistic, Signature, Sylvania, Symphonic, Tandy, Teac, Technika	044	Hitachi, JC Penny, Pentax, RCA, Sears	067	Fisher	
009			045	Hitachi	069	LG(Goldstar)	
011	025	Audio Dynamics, DB, JC Penny, JCL, Kenwood, Marantz, NEC, Pioneer, Sansui	046	RCA	070	Marantz, NEC	
014			047	Sony	071	Emerson	
015	026	Akai, Shintom, Sony	048	Sharp	073	Curtis Mathes, NEC	
016			027	Fisher, Sears	074	Emerson	
017	Admiral, Optimus, Radio Shack, Realistic, Sharp	028	Fisher, Radio Shack, Realistic, Sears, Toshiba	050	Emerson, Scott	076	Curtis Mathes, Emerson, TMK
		029	Emerson	051	Emerson, Samsung	077	Emerson, Scott
018	Candle, Citizen, Craig, Curtis Mathes, General Electric, Go Video, JC Penny, MTC, Multitech, RCA, Samsung, Television	030	Technika	052	Fisher, Radio Shack, Realistic, Sears	078	RCA, Teac
		031	Akai, Samsung	053	Portland, Quasar	079	Emerson
019	Canon, Curtis Mathes, Emerson, General Electric, Instant Replay, JC Penny, JCL, Magnavox, Marantz, Panasonic, Philco, Philips, Quasar, Radio Shack, Realistic, RCA, Sylvania, Technics, Technika	032	Akai, Emerson	054	Candle, Citizen, Daewoo, Portland, Sharp	082	KLH
		033	Shintom, Sony	055	Candle, Citizen, Curtis Mathes, LG(Goldstar), JCL, Kenwood, Marantz, NEC, Pentax Research+	084	Panasonic
020	Candle, Citizen, Emerson, LG(Goldstar), Radio Shack, Realistic, Sears, TOSHIBA, Technika, Television	034	Emerson	056	Emerson	085	Daewoo
		035	Shintom, Sony	057	Fisher, Sears, Toshiba	086	Panasonic
021	Daewoo	036	Electrohome, Emerson, Radio Shack, Realistic, Sharp	058	Emerson, Scott, Toshiba	088	Admiral

DVD Remote Control Codes

000	Samsung	003	JVC	006	Panasonic	009	Curtis Mathes
001	LG(Goldstar)	004	Sony	007	Philips		
002	Toshiba	005	Sharp	008	PROSCAN, RCA		

Programming the Remote Control for Other Components

ENG

Cable Box (CATV) Remote Control Codes

000	Samsung	020	Eastern International, Hamlin, Regal	038	GI, Jerrold	057	Tocom
001	Nawoo			039	Unika	058	
002	TaePyungYang	021	Hamlin, Regal	040	Magnavox, Philips, Unika, Viewstar	059	Universal
003	DeaRyung	022	Zenith			060	
004	DongKuk	023	GI, Jerrold	041	Magnavox, Philips, Regency, Viewstar	063	Tocom
005	DaeHan	024	Oak, Osk Sigma			065	Zenith
006	LG(Goldstar)	025	Tocom	042	Hamlin	066	Stargate 2000
007	Saewoo	026	Pioneer	044	GI, Jerrold	067	Sylvania, Texscan
008	RCA	027	Magnavox, Philips, Viewstar	045	Hitachi, Macom	069	Panasonic, Zenith
010	Regency	028	Pioneer	046	Oak	070	Jerrold
011	Hamlin, Panasonic, Regal, Samsung	029	Magnavox, Philips, Tocom, Viewstar	047	Panasonic	071	Samsung
				048	Magnavox, Philips, Viewstar	072	
012	GI, Hamlin, Jerrold	030	Samsung	049	Magnavox, Philips, Unika, Viewstar	073	Jerrold
013	GI, Jerrold	031				074	RCA
015	Anvision, Cable Star, Eagle,	032	GI, Jerrold	050	Zenith	075	
016	Magnavox, Philips, Randtek, Viewstar	033		051	Hitachi, Macom	076	GI
		034	Magnavox, Philips, Viewstar	052	Pioneer, Samsung, Warner Amex	077	
017	NSC	035	RCA, Panasonic, Sprucer	054	General Instrument, Hitachi, Jerrold, Signature, Starcom		
019	Sylvania, Texscan	036					
		037	Magnavox, Philips, Viewstar	056	Hamlin		

Troubleshooting: Before Contacting Service Personnel

ENG

Before contacting Samsung after-sales service, perform the following simple checks.

If you cannot solve the problem using the instructions below, note the model and serial number of the television and contact your local dealer.

No sound or picture	<ul style="list-style-type: none">◆ Check that the mains lead has been connected to a wall socket.◆ Check that you have pressed the "I" button (On/Off) and the POWER (⏻) button.◆ Check the picture contrast and brightness settings.◆ Check the volume.
Normal picture but no sound	<ul style="list-style-type: none">◆ Check the volume.◆ Check whether the volume MUTE (⏻) button on the remote control has been pressed.
No picture or black and white picture	<ul style="list-style-type: none">◆ Adjust the colour settings.◆ Check that the broadcast system selected is correct.
Sound and picture interference	<ul style="list-style-type: none">◆ Try to identify the electrical appliance that is affecting the television, then move it further away.◆ Plug your television into a different mains socket.
Blurred or snowy picture, distorted sound	<ul style="list-style-type: none">◆ Check the direction, location and connections of your aerial. This interference is often occurs to the use of an indoor aerial.
Remote control malfunctions	<ul style="list-style-type: none">◆ Replace the remote control batteries.◆ Clean the upper edge of the remote control (transmission window).◆ Check the battery terminals.

Memo

ENG

Memo

ENG

Large empty rectangular box for writing the memo content.

Memo

ENG

– AFTER SALES SERVICE

- Do not hesitate to contact your retailer or service agent if a change in the performance of your product indicates that a faulty condition may be present.

