



User Guide

BT DIVERSE 5200

ADDITIONAL HANDSET AND CHARGER

SIEMENS

digitally
enhanced



This equipment is not designed for making emergency telephone calls when the power fails. Alternative arrangements should be made for access to emergency services.

At a glance



**Please open this page for an 'At a glance' guide to your
BT Diverse 5200 Additional Handset and Charger.**

Base

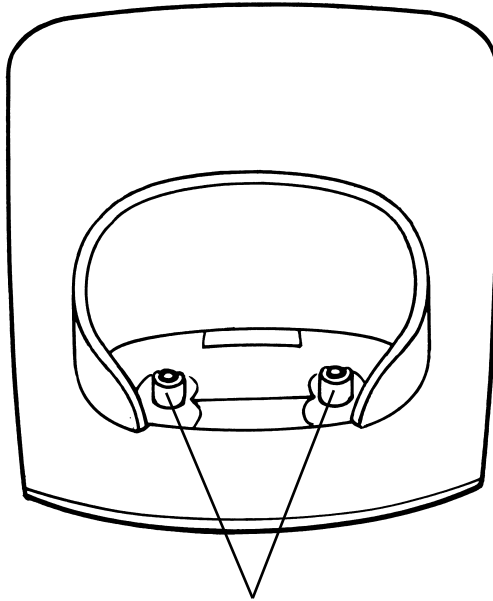

Contact points

Base underside

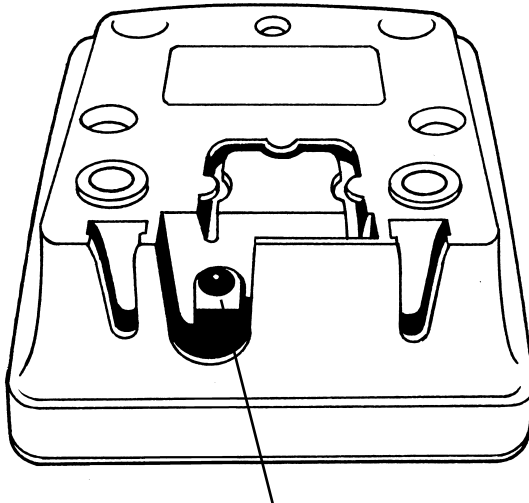

Power socket

In this guide

Please refer to the separate *Using SMS User Guide* for instructions on using the SMS functionality.

At a glance 1

Menu structure 4

Directory 5

Messages 5

Quick guide 6

Quick guide to handset display icons 7

Introduction 8

Unpacking your Diverse 5200

Additional Handset and Charger 8

For your records 8

Safety instructions 9

Setting up 10

Using the telephone 15

Making and ending calls 15

Handsfree 16

Using the directory 17

Character map 18

Redial 20

Secrecy 21

Internal calls 22

Caller Display and other BT Calling Features 24

Calls list 24

Call Waiting 27

Other BT Calling Features 27

Additional features 30

Voice mail 30

Handset settings 32

Help 37

General information 39

Guarantee 39

Technical information 39

Index 41

Hints and tips boxes

In this user guide, we've included helpful tips and important notes. They are shown in boxes like this.

Helpline

If you experience any difficulties with your Diverse 5200 Additional Handset and Charger, please call the BT Diverse Helpline on 08457 908 070.

Menu structure

Please note that you will only see all the below menu options if you are registered to a BT Diverse 5210 or Diverse 5250 base station.

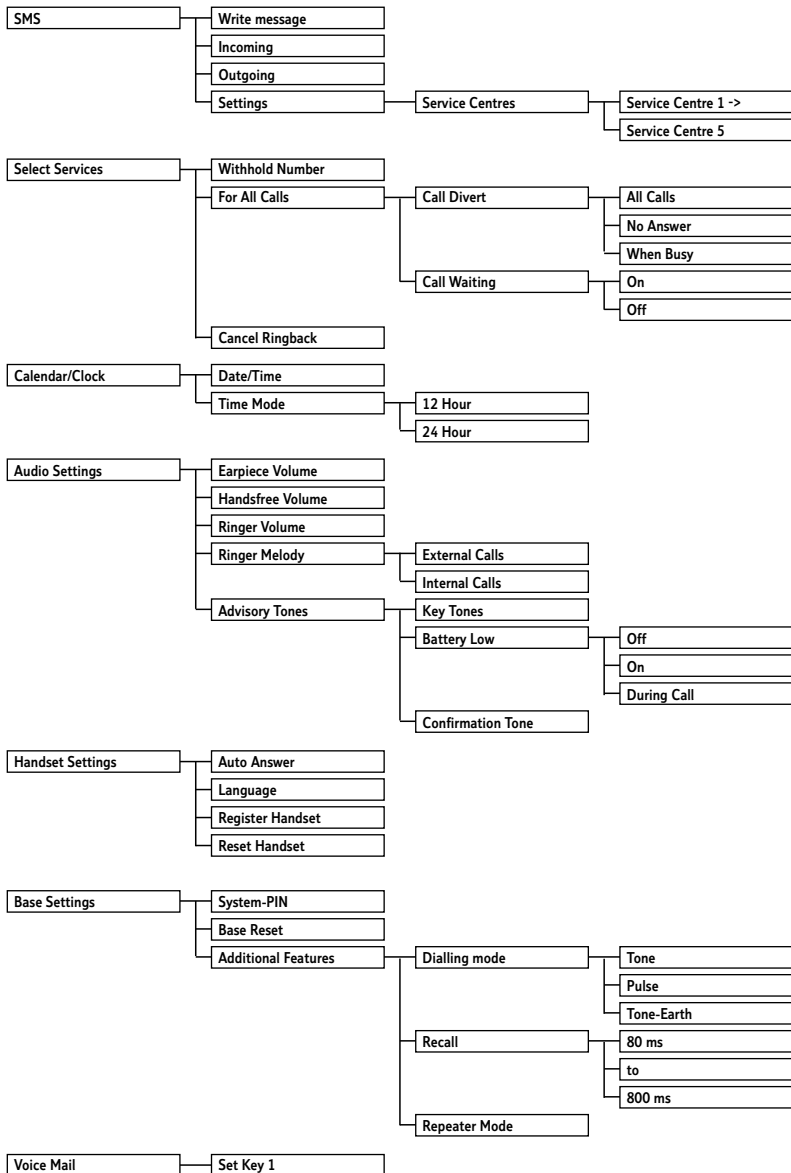

Note

If your handset is registered to a BT Diverse 5250 answering machine base, you will have additional menu's in Voice Mail. Please refer to your BT Diverse 5250 guide to see what further menus are now available.

Messages

Press  to get to your Mailbox and access your text messages, voicemail and Calls list.

The following functions are available:

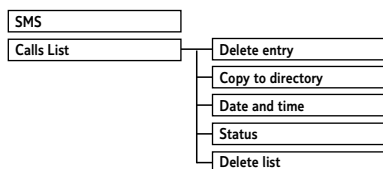



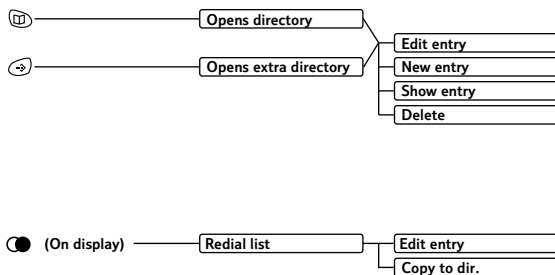











































Menu structure for directory, redial list, extra directory



Note

*If you make a mistake, you can return to the previous menu by pressing the **RED PHONE** button. If you keep pressing the **RED PHONE** button you will return to the idle screen.*

Quick guide

		Page no
Switch the handset OFF/ON: (default is ON)	 Hold down.	15
Switch Keyguard on/off	 Hold down.	35
Switch handset ringer off	 Hold down.	32
Make a call	  or   .	15
Redial a number	   to scroll through the list  to dial.	20
Copy a displayed number in the redial list to the directory	   Menu   to display Copy to directory OK OK add name Menu display shows Save entry OK  .	21
Dial from the directory	   to name or number you want to dial  .	19
Dial from Calls list	   to display Calls List OK   to display the number you want  .	25
Adjust handsfree volume whilst in handsfree mode	Menu Display shows Volume OK   to decrease/increase volume OK .	16
Adjust earpiece volume	Menu display shows Volume OK   to decrease/increase volume OK .	32
Make internal call	Int then   select handset and click on  .	22
Call all handsets	Int   to Call All  .	22
Transfer call to another handset	Int then   select handset and click on  . When user answers press  .	22
Put caller on hold while you make an internal call	Int then   select handset and click on  . When finished press Menu . Back will be selected press OK .	23
Set date and time	Menu   to display Calendar/Clock OK to display Date/Time OK enter date OK enter time OK . Select am/pm OK .	14

Quick guide to handset display icons



Redial, lists up to the last 5 dialled number.



Flashes to indicate new messages (e.g Calls or SMS).

INT

For calling other handsets.

MENU

Opens the menu.



Shows the status of the handset battery.



Scroll through the menu.

OK

Confirms the function displayed.



Scroll left and right when entering numbers or messages.



Deletes numbers/characters (from left to right).



Ringer off.



Handset locked.

eg. **7**

Shows the number of the handset and is displayed in top left hand corner.

Introduction

Unpacking your BT Diverse 5200 Additional Handset and Charger

If anything is missing, please contact your place of purchase immediately.

One BT Diverse 5200
Charger



One BT Diverse 5200
handset



One power supply
for the charger



Two AAA rechargeable
batteries

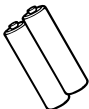

Battery compartment
cover



One belt clip



For your records

Date of purchase:

Place of purchase:

For guarantee purposes proof of purchase is required so please keep your receipt.

INTRODUCTION

Safety information

Safety information

General

Only use the power supply included with the product. Using an unauthorised power supply will invalidate your guarantee and may damage the telephone. Power supply number is C39280-Z4-C478.

For the handset use only AAA 1.2V Nickel Metal Hydride (NiMH) rechargeable batteries with a minimum capacity of 700 mAh. Never use other batteries or conventional alkaline batteries. They could lead to a short circuit or destroy the battery casing. Batteries and accessories are available from www.withandwithoutwires.com or call **0870 240 5522**.

If the Keyguard is switched on, it is NOT possible to make calls, including emergency numbers (**999/112**).

Do not open the base station or handset (other than to change batteries). This could expose you to high voltages or other risks.

Radio signals transmitted between the handset and base may cause interference to hearing aids.

This product should not be used near emergency/intensive care medical equipment and should not be used by people with pacemakers.

Never dispose of batteries in a fire. There is a serious risk of explosion and/or the release of highly toxic chemicals.

Cleaning

Simply clean the handset and base station with a damp (not wet) cloth, or an anti-static wipe. Never use household polish as this will damage the product. Never use a dry cloth as this may cause a static shock.

Environmental

Do not expose to direct sunlight.

The product may heat up when the batteries are being recharged. This is normal. However, we recommend that you do not place the product on antique/veneered wood to avoid damage.

Do not stand your product on carpets or other surfaces which generate fibres, or place it in locations preventing the free flow of air over its surfaces.

Do not submerge any part of your product in water and do not use it in damp or humid conditions, such as bathrooms.

Do not expose your product to fire, explosive or other hazardous conditions.

There is a slight chance that your phone could be damaged by an electrical storm. We recommend that you unplug the power and telephone line cord during an electrical storm.

Setting up

IMPORTANT

Please note that your handset is NOT registered to the base station. The BT Diverse 5200 additional handset will be easily registered once you complete the steps 1 to 3 below.

Plan the location

Situate your product close enough to the mains power socket so that the cable will reach.

Make sure it is at least 1 metre away from other electrical products to avoid interference.

Do not situate the product in the bathroom or other humid areas.

1 Connect the charger

Plug the power supply cable into the power socket on the underside of your charger.

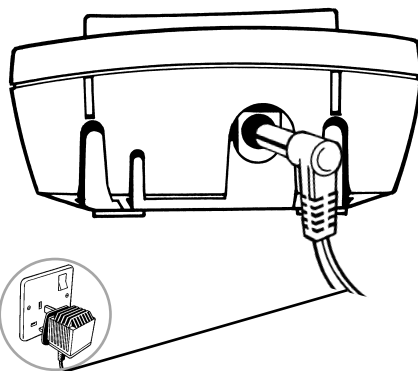

2 Plug the power supply unit into the wall socket

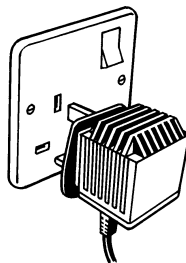

3 Registering and charging the handset

The display is protected by a plastic film. Remove the protective plastic film from the display.



Insert the batteries

Insert the two batteries supplied, as indicated inside the battery compartment and slide the battery compartment cover shut.

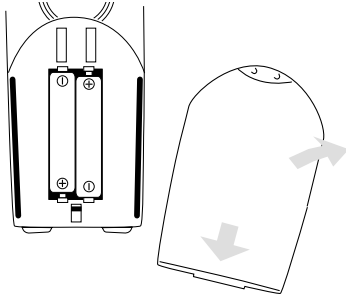

The battery cover may be found in the packaging with the batteries.

WARNING

Under no circumstances should non-rechargeable batteries be used. Only use AAA 1.2V Nickel Metal Hydride (NiMH) rechargeable batteries with a minimum capacity of 700mAh. Using inappropriate batteries will invalidate your guarantee and may damage the telephone. Batteries and accessories are available from www.withandwithoutwires.com or call 0870 240 5522.

Registering the handset

To register your handset to a BT Diverse 5210 or Diverse 5250 base station, place it in the base station with the display facing upward. After approx. one minute, the handset's internal number is displayed (e.g.: 1). Successful registration is signalled by a confirmation tone.

When the handset is registered the display will show:

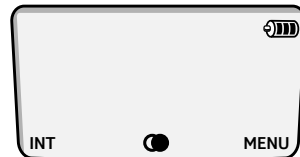

If the icons on the display flash continuously...

It means that the handset is not registered with the base station.

Ensure you have correctly carried out step 3 above. If the product has still not registered, please see "Registering manually" below.

All additional handsets you purchase will need to be individually registered with the base station before they will work with the BT Diverse 5200.

Leave the handset for approx. 16 hours in the base station to charge the batteries, as they are not charged in the factory. The battery status icon flashes on the handset to indicate that the batteries are being charged.

To manually register a BT Diverse 5200 handset to another base station

If you want to register your handset to another base station you will need to manually register it.

On the handset to be registered:

MENU Press the **MENU** options button.

↓ Press the **DOWN** navigation button until the display shows Handset Settings.

OK Press the **OK** options button.

↓ Press the **DOWN** navigation button until the display shows Register Handset.

OK Press the **OK** options button.



Enter system PIN.

OK Press the **OK** options button.



If the base station is a BT Diverse 5210 or 5250 base press the **PAGE** button for approximately three seconds.



After approximately one minute the handset will display its internal number. The handset is now registered and the handset display will return to the idle screen.

If the base is not a 5210 or 5250 you will need to follow the user guide for the base station you are registering the 5200 handset to.

Note





To make internal calls see page 22.

To de-register a handset

- INT** Press the **INT** navigation button to display the list of internal handsets registered to the base.
- ↑↓** Press the **UP** or **DOWN** navigation button to select the handset you want to de-register.
- MENU** Press the **MENU** options button.
- ↓** Press the **DOWN** navigation button until the display shows De-register Handset.
- OK** Press the **OK** options button.
-  Enter the base station PIN (original setting = 0000).
- OK** Press the **OK** options button.
Display shows de-register handset?
- OK** Press the **OK** options button to confirm de-registration.
-  Press the **RED PHONE** button to return to the idle screen.

Battery level icons

When the batteries are almost flat a beep sounds and the display shows the empty battery icon. You will need to recharge your handset before you can use it. The various states of charge are shown below:

-  Batteries fully charged
-  Batteries at 66%
-  Batteries at 33%
-  Batteries empty

Out of range?

If you go out of range of a base station for a long time while your handset is switched ON, it may take more than 20 minutes to 'find' the base station again when you come back within range. However, by simply switching the handset OFF for a moment, then ON again, it will find the base station within a few seconds.

Battery performance

Batteries and case may become warm during charging. This is normal.

Under ideal conditions, the handset batteries should give about 13 hours talktime or 170 hours standby time on a single charge. However, new NiMH batteries do not reach their full capacity until they have been in normal use for several days.

The charge capacity of rechargeable batteries will reduce with time as they wear out, so reducing the talk/standby time of the handset. Eventually they will need to be replaced. New batteries are available from







www.withandwithoutwires.com
or call **0870 240 5522**.

If you replace the handset batteries with ones that have been fully charged, the battery indicator will not show full until the next charge cycle has been completed. Charge the handset until the batteries register full again. From then on the display will be correct.

Note

If you subscribe to a Caller Display service the time and date will be set with the first incoming call. However, the year setting will have to be changed manually. See opposite.

Setting the date and time

- MENU** Press the **Menu** options button.
-  Press the **DOWN** navigation button until the display shows Calendar/Clock.
- OK** Press the **OK** options button. Date/Time appears.
- OK** Press the **OK** options button.
-  Enter the day/month/year, e.g. **05 10 03** for 5th October 2003.
- OK** Press the **OK** options button.
-  Enter the time – hours/minutes, e.g. **0925** for 9:25am.
- OK** Press the **OK** options button.
-  Use the **UP/DOWN** navigation buttons to select **am/pm** if in 12 hour mode.
- OK** Press the **OK** options button.
-  Press the **DOWN** navigation button to Time Mode.
- OK** Press the **OK** options button.
-  Use the **UP/DOWN** navigation buttons to select 12 or 24 hour display (12hr is the default).
- OK** Press the **OK** options button.
-  Press the **RED PHONE** button until you reach the idle display.

Using the telephone

Note

To exit a menu at any time, press the **RED PHONE** button. This will take you back one step. Keep pressing the **RED PHONE** button to return to the idle screen.

To switch the handset power on and off



Press *and hold* the **RED PHONE** button to switch the handset off.



Press and hold the **RED PHONE** button to switch the handset on again.

Making and ending calls

To make an external call

Ensure the handset is switched ON.



Press the **GREEN PHONE** button. You will hear the dial tone.



Dial the number.

Preparatory dialling



Enter the phone number first.



If you make a mistake press the **<C** options button to remove any incorrect digits.



Press the **GREEN PHONE** button to dial the number.

To end a call



Press the **RED PHONE** button.

Call timer

Your handset automatically times the duration of all external calls, showing it on the display during your call and for a few seconds after it is finished.

To receive an external call



Press the **GREEN PHONE** button to answer the call.

Or

If the handset is on the base, simply lift it up and speak.

You do not need to press the **GREEN PHONE** button.

This is called Autotalk. You can switch autotalk off so you always have to press the **GREEN PHONE** button to answer a call, see page 34.

To make a handsfree call



Dial the number



Press the **HANDSFREE** button. The loudspeaker is switched on and you hear the number being dialled.



To switch back to using the handset at any time, press the **GREEN PHONE** button.

To adjust the handsfree volume whilst in handsfree mode

Whilst in handsfree mode and you want to increase or decrease the handsfree volume.

MENU Press the **MENU** options button.

OK Press the **OK** options button to select volume.



Using the **LEFT** or **RIGHT** navigation buttons you can either increase or decrease the volume.

OK Press the **OK** options button if you want to save the new volume setting.

Handsfree

Handsfree allows you to talk to your caller without holding the handset and enables other people in the room to listen to the conversation. Your hands are left free, for example to take notes.

Note

You can test the handsfree function by dialling the BT speaking clock on 123.

To answer a call in handsfree

When the phone rings:



Press the **HANDSFREE** button.
The call is transferred to the loudspeaker.

To switch to handsfree during a call

During a call you can switch to handsfree mode:



Press the **HANDSFREE** button.
The call is transferred to the loudspeaker.



Press the **GREEN PHONE** button to switch back to using the handset.

Note

*If you need to replace the handset in the base station during a call, for example, because the battery is flat, hold down the **HANDSFREE** button.*

Using the directory

You can store up to 50 names and numbers in the telephone directory. You can enter up to 32 digits and up to 16 characters.

To store an entry in the directory



Press the **DIRECTORY** button.

MENU

Press the **MENU** options button.
Display shows **New Entry**.

OK

Press the **OK** options button.



Enter the telephone number.

OK

Press the **OK** options button to enter the name.



Enter the name.

Entering names:

Enter the name using the letters on the keypad. For example, to enter the name **TOM**:



Press the **8** button, **T** appears on the display.



Press the **6** button three times until the display shows **0**.



Then press the **6** button to display **m**.

For the full character map, see page 18.

MENU

Press the **MENU** options button. Display shows **Save Entry**.

OK

Press the **OK** options button to confirm.



Press the **RED PHONE** button until you reach the idle display.

Note

The first letter of each name, and the first letter after a punctuation mark are automatically shown as capitals. Letters are always added to the left of the cursor.

 Press to switch between capitals and lower case.













 Press to move the cursor.

 Press to delete from right to left.

 Press 1 to enter a blank space.

Character map

These are the characters you can use when storing a directory entry.

	1x	2x	3x	4x	5x	6x	7x	8x	9x	10x	11x	12x	13x	14x
	□	1	€	£	§	¥	¤							
	a	b	c	2	ä	á	à	â	ã	ç				
	d	e	f	3	ë	é	è	ê						
	g	h	i	4	ï	í	ì	î						
	j	k	l	5										
	m	n	o	6	ö	ñ	ó	ò	ô	õ				
	p	q	r	s	7	ß								
	t	u	v	8	ü	ú	ù	û						
	w	x	y	z	9	ÿ	ý	æ	ø	å				
	a→A	*	/	()	<	=	>	%					
	.	,	?	!	0	+	-	:	¿	¡	“	’	;	-
	#	@	\	&	§									

To dial a name and number in the directory



Press the **DIRECTORY** button.



Press the **DOWN** navigation button to scroll through the names which are listed in alphabetical order.

Or



Enter the first letter of the name you want, e.g. for Emma, press **3** *twice* to search for names beginning with E.



Press the **GREEN PHONE** button. The number is dialled.

To view directory entry



Press the **DIRECTORY** button.



Press the **DOWN** navigation button to scroll through the entries.

Or



Press the first letter of the name you are looking for.



Press the **RED PHONE** button until you reach the idle display.

To edit a directory entry



Press the **DIRECTORY** button.



Use the keypad to enter the first letter of the name you wish to edit.



Then press the **DOWN** navigation button to scroll to the exact entry.

MENU

Press the **MENU** options button.



Press the **DOWN** navigation button until **EDIT ENTRY** is displayed.

OK

Press the **OK** button.

Edit the number, if necessary, using the **LEFT/RIGHT** and **DELETE** buttons.



OK

Press the **OK** button. <NAME> is displayed.

If the name is correct, press the **MENU** button, **SAVE ENTRY** is displayed.

MENU

OK

Press the **OK** button. The display will show **ENTRY SAVED**.

Or

If you wish to edit the name, enter a new name now, using the **LEFT/RIGHT** and **DELETE** buttons as above.



MENU

Press the **MENU** button. The display will show **SAVE ENTRY**.

OK

Press the **OK** button. The display will show **ENTRY SAVED**.

To delete an entry



Press the **DIRECTORY** button and open the directory.



Press the **DOWN** navigation button to scroll to the entry you want to delete.

MENU

Press the **MENU** options button.



Press the **DOWN** navigation button until the display shows **Delete Entry**.

OK

Press the **OK** options button to confirm. You hear a confirmation beep.



Press the **RED PHONE** button until you reach the idle display.

Extra directory

Your Diverse 5200 has an additional 10 name and number directory. It is recommended that this is used for special numbers i.e. doctor, dentist, takeaway numbers.



Press the **EXTRA DIRECTORY** button.

The structure of this directory is the same as the main directory. You can follow the instructions starting on page 17 for storing, dialling, viewing, editing and deleting these names and numbers.

To delete the entire directory



Press the **DIRECTORY** button and open the directory.

MENU

Press the **MENU** options button.



Press the **DOWN** navigation button until the display shows **Delete List**.

OK

Press the **OK** options button. **Delete List?** is displayed.

OK

Press the **OK** options button.



Press the **RED PHONE** button until you reach the idle display.

Redial

Your handset automatically saves the last 10 telephone numbers dialled into a redial list.

To dial a number in the redial list



Press the **REDIAL** options button. The last number dialled will be displayed.



Press the **DOWN** navigation button to scroll through the redial list.



Press the **GREEN PHONE** button to dial the number.

To copy numbers shown in the redial list to the directory

 Press the **REDIAL** options button.

 Press the **DOWN** navigation button to scroll to the number you want to copy.

MENU Press the **MENU** options button.

 Press the **DOWN** navigation button until the display shows **COPY to Directory**.

OK Press the **OK** options button.

OK Press the **OK** options button again.

Enter the name (for details, see page 17).

MENU Press the **MENU** options button. The display shows **Save Entry**.

OK Press the **OK** options button to confirm.

 Press the **RED PHONE** button until you reach the idle display.

Note

*To cancel any procedure, press the **RED PHONE** button until the display returns to idle.*

To delete a number from the redial list

 Press the **REDIAL** options button.

 Press the **DOWN** navigation button to select the number for deletion.

MENU Press the **MENU** options button.

 Press the **DOWN** navigation button until the display shows **Delete Entry**.

OK Press **OK** to confirm deletion.

 Press the **RED PHONE** button until you reach the idle display.

Secrecy

When on a call you can talk to someone in the same room, without your caller hearing.

To switch secrecy on/off

During a call:

INT Press the **INT** navigation button. The microphone is switched off. The caller hears musical tones.

 Press the **RED PHONE** button to return to the caller.

Internal calls

If you have multiple handsets registered to the base you can make internal calls between handsets.

INT Press the **INT** options button.

A list of all the handsets that are registered to the base are listed, you can select any of them.

Your handset is identified by INT 1 <.



Press the **DOWN** navigation button to highlight the handset you want to call and press the **GREEN PHONE** button.



Or



Press the handset number you want to call on the keypad.

Or

Call All

Select the **Call All** option to page all the handsets registered to the base and press the **GREEN PHONE** button.



The line will be seized by the first handset user to answer the call.

Note

*You can also page all handsets by pressing the **PAGE** button on the base station.*

To transfer an external call between handsets

You can forward an external call to another handset registered to the base.

During an external call:

INT

Press the **INT** navigation button to display the list of handsets. Your caller hears musical tones.



Press the **UP** or **DOWN** navigation button to select the handset you want to call or **Call all handsets**.



Press the **GREEN PHONE** options button to call. When the other handset answers you can announce the call.



Press the **RED PHONE** button to put the call through.

Note

*You can also put the call through without announcing it by immediately pressing the **RED PHONE** button after dialling the other handset.*

To put an external call on hold while you make an internal call

This enables you to ask another handset user a question and then get straight back to your caller.

During a call:

INT Press the **INT** options button to display the list of handsets. Your caller hears musical tones.

 Press the **UP** or **DOWN** navigation button to select the handset you want to call.

Or

 Press the handset number you want to call on the keypad.

 Press the **GREEN PHONE** button to call.

You can now speak with the other handset user.

To return to your external caller:

MENU Press the **MENU** button and **Back** will be displayed.

OK Select the **OK** options button which will reconnect you to the external call.

To answer a waiting call during an internal call

If you are making an internal call and hear the Call Waiting tone you can immediately take the incoming call.

MENU Press the **MENU** button.

OK To accept Call Waiting, press the **OK** options button.

Or

 To reject Call Waiting, press the **DOWN** navigation button.

The display shows **reject Call Waiting**.

OK Press the **OK** options button.

Note

If you accept Call Waiting you will automatically terminate your internal call.

Caller Display and other BT Calling Features

IMPORTANT

To use Caller Display and Call Waiting you must first subscribe to the Services from your Network Provider. For more information on BT's Calling Features call BT free on **0800 800 150**.

Note

Calls that are 'withheld', 'unavailable' or 'international' are not stored in the Calls list, as there is no telephone number sent via the Network.

If you subscribe to a Caller Display Service you can see who is calling you on your handset display, as well as the date and time of their call (unless the number has been withheld).

If you have stored a name to go with the number in your handset directory, the name will be displayed instead.

Please ensure that you have stored the full telephone number, including the area code, otherwise the name will not match the number stored in the directory.

If the caller has withheld their number, the display will show **WITHHELD**.

If you call from another handset, the display shows the handset number and **INT**.

Note

If you have a new call in your Calls list, the  icon will flash on the handset.

Calls list

The Calls list contains the telephone numbers of your last 10 callers.

Whether you take a call or not, the caller's details are stored in the Calls list. You can display, scroll through and dial numbers in the list and copy them into the directory.

If a call is received when the Calls list is full then the oldest entry will be deleted automatically.

The  button lets you open:

- Calls list.
- Network mailbox.
- Text messages (SMS).

To view the Calls list

When you have new calls, the  icon flashes in the display.



Press the **ENVELOPE** button.



Press the **DOWN** navigation button until the display shows, e.g. Calls List: 03+07.

In this example, you have received 3 new calls and you have 7 old calls (calls you have already viewed).

OK

Press the **OK** options button to display the most recent number that called you.



Press the **UP** or **DOWN** navigation button to display all your new calls, followed by all your old calls.

Note

*To exit the Calls list at any time, press the **RED PHONE** button until you reach the idle display.*

WHEN A CALLS LIST ENTRY IS DISPLAYED YOU HAVE THE FOLLOWING OPTIONS:



To call the number:

Press the **GREEN PHONE** button. The number displayed is dialled.

To display the date and time the call was received:

MENU Press the **MENU** options button.



Press the **DOWN** navigation button until the display shows Date and Time.

OK

Press the **OK** options button. The date and time of the call are displayed.

OK

Press the **OK** options button to return to the Calls list.

To display the status of the call:

MENU Press the **MENU** options button.



Press the **DOWN** navigation button until the display shows Status.

OK

Press the **OK** options button. The display shows whether the call is a **New Call** or an **Old Call** and the number of the call in the Calls list, e.g. 01/10 – the first call in a list of ten.

OK

Press the **OK** options button to return to the Calls list.

To copy a number from the Calls list to the directory:

- MENU** Press the **MENU** options button.
-  Press the **DOWN** navigation button until the display shows `Copy to Directory`.
- OK** Press the **OK** options button.
The number is displayed.
- OK** Press the **OK** options button.
The display shows `<Enter Name>`.





Enter the name of the person using the keypad.

- MENU** Press the **MENU** options button.
The display shows `Save Entry`.
- OK** Press the **OK** options button.
`Entry Saved` is displayed.
The display automatically returns to show the Calls list.

To delete a call from the Calls list:

- MENU** Press the **MENU** options button.
The display shows `Delete Entry`.
- OK** Press the **OK** options button.
The display shows `Entry has been deleted!`
The display then shows the next Calls list entry.

To delete the whole Calls list:

- MENU** Press the **MENU** options button.
-  Press the **DOWN** navigation button until the display shows `Delete List`.
- OK** Press the **OK** options button.
The display shows `Calls list empty!`
-  Press the **RED PHONE** button until you reach the idle display.

CALLER DISPLAY

Call Waiting

If you also subscribe to a Call Waiting Service, when you are on a call and another person tries to call you, the second caller's number will appear on the handset display and you will hear an intermittent beep through the handset. This is to alert you to the other caller waiting to speak to you.

To accept a waiting call

During a call when you hear the Call Waiting beeps:

The number (and name if stored in the directory) of the second caller will flash on the display.

MENU Press the **MENU** options button.

Display shows `Accept Call Waiting`.

Press the **OK** options button.

OK



Press the **UP** or **DOWN** navigation buttons to toggle between callers.

Other BT Calling Features

Your Diverse 5200 additional handset helps you use your Network's special services. For full details ask your Network provider.

Options before you make a call

Before making a call you can:

- Withhold your number from being sent for one call.
- Switch Call Waiting on/off.
- Switch off Ringback.
- Divert all calls to another number (must be subscribed to).

To withhold your number from being sent

Your number appears on the display of the person you call. You can withhold it from the next call.

MENU Press the **MENU** options button.



Press the **DOWN** navigation button until the display shows `Select Services`.

OK Press the **OK** options button.

The display shows `Withhold Number`.

OK Press the **OK** options button.



Enter the telephone number you want to call.

OK Press the **OK** options button to dial.

The number is dialled and your number is withheld for this call.

To switch Call Waiting on/off

You can choose whether to have your Call Waiting service switched on or off depending on what you are doing i.e. if you are using the Internet via your PC and do not want Call Waiting to interrupt you.

MENU Press the **MENU** options button.

↓ Press the **DOWN** navigation button until the display shows `Select Services`.

OK Press the **OK** options button.

↓ Press the **DOWN** navigation button until the display shows `For All Calls`.

OK Press the **OK** options button.

↓ Press the **DOWN** navigation button until display shows `Call Waiting`.

OK Press the **OK** options button.

↓ Press the **DOWN** navigation button to choose between `On` or `Off`.

OK Press the **OK** options button.

 Press the **RED PHONE** button until you reach the idle display.

Ring Back Off

If you make a call and the number is engaged you can set your telephone to ring you back once the number is free by pressing **5**. If you want to cancel this request i.e. if you have to go out before the call rings back.



MENU Press the **MENU** button.

Display shows `Select Services`.

OK Press the **OK** options button.

↓ Press the **DOWN** navigation button until `Cancel Ringsback` is displayed.

OK Press the **OK** options button.

You will hear a Network message confirming your divert request.



Press the **RED PHONE** button until you reach the idle display.

To set Call Divert

Note

Call Divert requires subscription from your Network provider. You may be charged a subscription fee.

You can divert all incoming calls to another number where you can be reached.

You can divert calls:

- **All calls** – calls are put straight through to the number you have set.
- **No answer** – calls are forwarded if your phone is not answered.
- **When busy** – calls are forwarded if your phone is engaged.

MENU Press the **MENU** options button.

↓ Press the **DOWN** navigation button until the display shows **Select Services** highlighted.

OK Press the **OK** options button.

↓ Press the **DOWN** navigation button until the display shows **For All Calls**.

OK Press the **OK** options button.
Display shows **Call Divert**.

OK Press the **OK** options button again.



Press the **UP** or **DOWN** navigation button to display the option you want **All Calls**, **No Answer** or **When Busy**.

OK

Press the **OK** options button again.



Select **On** or **Off**.

OK

Press the **OK** options button.

Enter the telephone number you want your calls diverted to.

OK

Press the **OK** options button.

You will hear a Network message confirming your divert request.





Press the **RED PHONE** button until you reach the idle display.

Additional features

Voice Mail

If you have Call Minder or a Network Messaging Service on your telephone line you can set the 1 button to access your messages.

To set one-touch access to your messages

- MENU** Press the **MENU** options button.
-  Press the **DOWN** navigation button until the display shows Voice Mail.
- OK** Press the **OK** options button.
The display shows Set Key 1.
- OK** Press the **OK** options button.
The display shows Network Mailbox.
- OK** Press the **OK** options button.
-  Enter the telephone number of your messaging service.
For example, **1571** to access the 'BT Answer' voice mail service.
- OK** Press the **OK** options button.
Display shows Entry Saved.
-  Press the **RED PHONE** button until you reach the idle display.

To set up quick access to your Voice Mail service when behind a switchboard e.g. Meridian Mail

Follow the steps previously given, but when you come to enter the telephone number of your messaging service, you will need to follow the example below:



Enter the access number for your messaging service, e.g. 7000.



Press *and hold* the **RECALL** button until P is displayed to enter a pause in the dialling sequence.



Enter your extension number, followed by a hash, e.g. 1234 #.



Press *and hold* the **RECALL** button until P is displayed to enter another pause in the dialling sequence.



Enter your PIN followed by a hash, e.g. 000000 #.



The entire number should look like this:

7000P1234#P000000#

OK Press the **OK** options button.



Press the **RED PHONE** button until you reach the idle display.

Note

If you store your security PIN as part of the quick access number, anyone with access to the handset will be able to retrieve your messages.

Note

If your handset is registered to an answering machine base i.e. BT Diverse 5250 you will be given the choice of accessing your answering machine messages or Network Messaging Service. See your BT Diverse 5250 user guide for further information.

To retrieve messages from your Voice Mail service



Press and *hold down* the **1** button.

When set up it will take you into your message service. If during the set up you entered your security PIN as well as the telephone number you will be taken quickly into your messages. If the security PIN was not included you will have to enter this number now, followed by a **#**.



You will then be taken into your messages.



Press the **RED PHONE** button until you reach the idle display.

Handset settings

You can choose a range of settings to suit your personal preferences.

To change the earpiece volume and handsfree volume

You can choose from:

- 3 earpiece volume levels
- 5 levels handsfree loudspeaker volume levels.

MENU Press the **MENU** options button.

↓ Press the **DOWN** navigation button until the display shows Audio Settings.

OK Press the **OK** options button.
The display shows Earpiece Volume.

OK Press the **OK** options button.
You hear the current handsfree volume.

← → Press the **LEFT** or **RIGHT** navigation button to set the volume level you want.

OK Press the **OK** options button.

↓ Press the **DOWN** navigation button to select the handsfree volume.

OK Press the **OK** options button.
You hear the current handsfree volume.

← → Press the **LEFT** or **RIGHT** navigation button to set the volume level you want.

OK Press the **OK** options button to confirm and save the settings.



Press the **RED PHONE** button until you reach the idle display.

To set the ringer volume and melody

You can choose from:

- 5 ringer volumes (original setting = 3)
- Crescendo ring (increasing volume)
- Ringer off
- 10 ringer melodies

MENU Press the **MENU** options button.

↓ Press the **DOWN** navigation button until the display shows Audio Settings.

OK Press the **OK** options button.

↓ Press the **DOWN** navigation button until the display shows Ringer Volume.

OK Press the **OK** options button.
You hear the current ringer volume.



Press the **LEFT** or **RIGHT** navigation button to set the ringer level you want.

OK Press the **OK** options button.



Press the **DOWN** navigation button to select the ringer melody.

OK Press the **OK** options button.

Select whether external calls or internal calls:

OK Press the **OK** options button.



Press the **UP** or **DOWN** navigation button to set the ringer melody you want. The melody is played and its number shown.

OK Press the **OK** options button to confirm and save the settings.

A ✓ is displayed next to the Set melody.



Press the **RED PHONE** button until you reach the idle display.

To change the display language

MENU Press the **MENU** options button.



Press the **DOWN** navigation button until the display shows Handset Settings.

OK Press the **OK** options button.



Press the **DOWN** navigation button until the display shows Language.

OK Press the **OK** options button.





Press the **DOWN** navigation button to display the language you want.

OK Press the **OK** options button to confirm.



Press the **RED PHONE** button until you reach the idle display.

Shortcut button

If you want to switch the handset ringer off quickly you can also press and hold the  button. The  icon is displayed. To turn the handset ringer back on press and hold down the  button again and the symbol will disappear.

To switch off your handset's beeps and tones

You can switch off and on:

- Key beeps when you press each button on your handset
- Confirmation beeps when you have finished making a setting or action on your handset.
- Battery Low warning beep. You can also set this to sound only during a call.

MENU Press the **MENU** options button.

↓ Press the **DOWN** navigation button until the display shows **Audio Settings**.

OK Press the **OK** options button.

↓ Press the **DOWN** navigation button until the display shows **Advisory Tones**.

OK Press the **OK** options button.

OK Press the **OK** navigation button to switch the key tones **On** or **Off**.

↓ Press the **DOWN** navigation button to move to the next line.

OK Press the **OK** options button.

↑↓ Press the **UP** or **DOWN** navigation button to switch the battery low beep **On** or **Off** or to sound only during a call.

OK Press the **OK** options button to confirm the settings.

 Press the **RED PHONE** button until you reach the idle display.

To switch auto talk on or off

When you receive a call, you can answer it simply by lifting the handset off the base station. This is called auto-talk. When you switch auto-talk off, you answer all calls by pressing the **GREEN PHONE** button.



MENU Press the **MENU** options button.



Press the **DOWN** navigation button until the display shows **Handset Settings**.

OK Press the **OK** options button.

The display shows **Auto Answer**.

OK Press the **OK** options button. A **✓** indicates auto talk is switched on. Press the **OK** options button again to switch auto-talk off.



Press the **RED PHONE** button until you reach the idle display.

To reset a handset

You can restore a handset to its factory settings.

The handset's Registration, the Directory and the Calls list are not affected.

MENU Press the **MENU** options button.

↓ Press the **DOWN** navigation button until the display shows Handset Settings.

OK Press the **OK** options button.

↓ Press the **DOWN** navigation button until the display shows Reset Handset.

OK Press the **OK** options button.

The display shows `reset to default?`

OK Press the **OK** options button to confirm reset.

The settings after a reset will be:

Ringer volume	3
Ringer melody	1
Auto talk	On
Battery low beep	On
Room monitor level	off
Room monitor level	high
Time control	off
Display language	English
Redial list	deleted



Press the **RED PHONE** button until you reach the idle display.

To switch keyguard on and off

You can lock the keypad so that it cannot be used accidentally while carrying it around.



Press and hold the **#** button. When the keyguard is switched on, the display will show the  icon.



Press and hold the **#** button to switch the keyguard off.

To change the internal number of a handset

Your handsets are automatically assigned internal numbers between 1-6. You can change these numbers.

INT Press the **INT** options button to display the list of handsets.



Press the **UP** or **DOWN** navigation button to select the handset you want.

MENU Press the **MENU** options button.

Edit Handset No. is displayed.

OK Press the **OK** options button.



Enter an available number.
If the number is already assigned to another handset you hear a beep. Select another number.



If required, press the **UP** or **DOWN** navigation button to select another handset and use the Keypad to change the number.

OK

Press the **OK** options button to confirm.



Press the **RED PHONE** button until you reach the idle display.

Help

Try these solutions to the most common problems.

Problem	Possible cause	Solution
Handset not registering.	The base is not powered. There are no batteries in the handset.	Make sure that the power supply is plugged in at the base and switched on. Make sure that the rechargeable batteries (included) are fitted in the handset correctly. Switch the handset off and then back on again, place the handset on to the base again and leave for approx. 1 minute to try registering again. If this is still unsuccessful, then try a manual registration (see page 12).
You have forgotten your base station PIN number.	You have changed the PIN.	Try entering the default PIN (0000). If you have changed the PIN and cannot remember the number you will need to contact the BT Diverse Helpline on 08457 908070.
No display.	The handset is switched off.	Hold down RED PHONE for 1 second. Charge or replace the batteries.
Nothing happens when you press any button.	Keypad may be switched on.	Hold down the # button for 1 second.
No connection between handset and base station.	Are you out of range of the base station. Handset is not registered. Charger is not switched on.	Move closer to the base station. Register the handset. Check the mains power is connected correctly.
Handset on the charger does not charge.	Is another handset using the line for a long time? Is the handset placed on the charger properly? Are the batteries in correctly?	Maximum charging power is only possible when no calls are being made. Make sure that the handset is placed in the charger correctly. You will hear a confirmation tone. Check that you have put the batteries in the right way, you will hear a confirmation tone.

Handset does not ring.	The handset ringer may be switched off.	Hold down * to switch the ringer back on.
The incoming caller's number is not displayed even though you have Caller Display.	The caller's number has been withheld.	Caller has to allow their number to be sent.
You keep hearing the error beep (a descending tone).	You have pressed the wrong button in a sequence.	Check the prompts in the display or refer to instructions in the user guide.

General information

Guarantee

Your BT Diverse 5200 Additional Handset and Charger is guaranteed for a period of 12 months from the date of purchase.

Subject to the terms listed below the guarantee will provide for the repair of, or at BT's or its agent's discretion the option to replace the BT Diverse 5200, or any component thereof, (other than batteries), which is identified as faulty or below standard, or as a result of inferior workmanship or materials. Products over 28 days old from the date of purchase may be replaced with a refurbished product.

The conditions of this guarantee are:

- The guarantee shall only apply to defects that occur within the 12 month guarantee period.
- Proof of purchase is provided.
- The equipment is returned to BT or its agent as instructed.
- This guarantee does not cover any faults or defects caused by accidents, misuse, fair wear and tear, neglect, tampering with the equipment, or any attempt at adjustment or repair other than through approved agents.
- This guarantee does not affect your statutory rights.

Within the 12-month guarantee period:

If you experience difficulty using the product, prior to returning your product, please read the Help section beginning on page 37, or contact the BT Diverse Helpline on **08457 908070** for assistance.

In the unlikely event of a defect occurring, please follow the Helpline's instructions for replacement or repair.

Outside the 12-month guarantee period:

If your product needs repair after the guarantee period has ended, the repair must meet the approval requirements for connection to the telephone network. We recommend that you call the Helpline on **08457 908070** and ask for details of our recommended repair agents.

BT Accessories and Replacement Items

For a full range of accessories and replacement items for BT products please call **0870 240 5522**, or visit:



With **and** Without **Wires.com**

BT Diverse Helpline – 08457 908 070

Technical information

How many telephones can you have on the line?

All items of equipment have a Ringer Equivalence Number (REN) which is used to calculate the number of items that may be connected to any one telephone line.

The BT Diverse 5200 (with up to 6 handsets) has a total REN of 1.

Any other instrument provided by BT may be assumed to have a REN of 1 unless stated otherwise.

A total REN of 4 is allowed per telephone line. (For example: if the BT Diverse 5200 is used in conjunction with three extension telephones, each with a REN of 1, then the total REN = 4)

Only use approved power supply item code C39280-Z4-C478.

R&TTE

This product is intended for use within the UK for connection to the public telephone network and compatible switchboards.

This equipment complies with the essential requirements for the Radio Equipment and Telecommunications Terminal Equipment Directive (1999/5/EC). In demonstration with the Essential Requirement for efficient use of the radio spectrum, the product complies with TBR6. For a copy of the Declaration of Conformity please contact the BT Diverse Helpline.

BT Diverse Helpline – 08457 908 070

Index

A uto talk on/off	34	directory entry	20
		redial list	21
B atteries		De-register handset	13
charging	11	Directory	17
installing	11	character map	18
performance	14	delete all entries	20
replacing	14	delete an entry	20
warning beeps	13	dial a number	19
Beeps and tones	34	edit an entry	19
		extra directory	20
C all timer	15	store name and number	17
Call Waiting	27	view an entry	19
Caller Display	24	Display icons	7
Calling Features	24	E arpiece volume	32
Calls		Ending calls	15
end	15	External calls	15
external	15	Extra directory	20
handsfree	16	G uarantee	39
holding	23	H andset	
internal	22	beeps and tones	34
making	15	change internal number	35
on hold	23	display	7
receiving	16	melody	32
redial	20	on/off	15
secrecy	21	reset	35
transferring	22	ringer	32
Character map	18	Handset quick guide	6
D ate set	14	Handsfree	16
Delete		Help	37
all directory numbers	20	Holding calls	23
calls list call	26		
complete calls list	26		

I nternal calls	22	S afety information	9
Internal number – change	35	Secrecy	21
K eyguard	35	Setting up	10
L anguage change	33	T echnical information	40
M aking calls	15	Time – set	14
Melody	32	Transferring calls	22
Menu structure	4	V oice mail	30
Music on hold	X	retrieve messages	31
O n/off		set one-touch access	30
auto talk	34	set up quick access behind switchboard	30
beeps and tones	34	V olume	
handset power	15	earpiece	32
keyguard	35	handset ringer	32
secrecy	21	handsfree	16
P ower connection	10		
Preparatory dialling	15		
Q uick guide			
display	7		
handset	6		
R ange warning	13		
Receiving calls	16		
Redial	20		
copy to directory	21		
delete	21		
dial number in redial list	20		
Registering handset	11		
manually	12		
REN, how many phones can I have?	40		
Reset			
handset settings	35		

Visit us at www.bt.com



Offices worldwide

The Telecommunications services described in this publication are subject to availability and may be modified from time to time. Services and equipment are provided subject to British Telecommunications plc's respective standard conditions of contract. Nothing in this publication forms any part of any contract.

Touchtone™ is a registered trade mark of British Telecommunications plc in the UK.

© British Telecommunications plc 2003.
Registered Office: 81 Newgate Street, London EC1A 7AJ.
Registered in England No. 1800000.
Diverse 5200 handset & charger Issue 1 (05/03) 4
Designed by The Art & Design Partnership Limited.

Siemens number: A31008-C001-P001-1-7619

CE 0682

CE compliant to R&TTE Directive (1999/5/EC)