



Avaya 1110 IP Deskphone User Guide

Avaya Communication Server 1000

Document Status: **Standard**

Document Version: **07.01**

Part Code: **NN43110-101**

Date: **October 2010**



© 2010 Avaya Inc. All Rights Reserved.

Notices

While reasonable efforts have been made to ensure that the information in this document is complete and accurate at the time of printing, Avaya assumes no liability for any errors. Avaya reserves the right to make changes and corrections to the information in this document without the obligation to notify any person or organization of such changes.

Documentation disclaimer

Avaya shall not be responsible for any modifications, additions, or deletions to the original published version of this documentation unless such modifications, additions, or deletions were performed by Avaya. End User agree to indemnify and hold harmless Avaya, Avaya's agents, servants and employees against all claims, lawsuits, demands and judgments arising out of, or in connection with, subsequent modifications, additions or deletions to this documentation, to the extent made by End User.

Link disclaimer

Avaya is not responsible for the contents or reliability of any linked Web sites referenced within this site or documentation(s) provided by Avaya. Avaya is not responsible for the accuracy of any information, statement or content provided on these sites and does not necessarily endorse the products, services, or information described or offered within them. Avaya does not guarantee that these links will work all the time and has no control over the availability of the linked pages.

Warranty

Avaya provides a limited warranty on this product. Refer to your sales agreement to establish the terms of the limited warranty. In addition, Avaya's standard warranty language, as well as information regarding support for this product, while under warranty, is available to Avaya customers and other parties through the Avaya Support Web site: <http://www.avaya.com/support>

Please note that if you acquired the product from an authorized reseller, the warranty is provided to you by said reseller and not by Avaya.

Licenses

THE SOFTWARE LICENSE TERMS AVAILABLE ON THE AVAYA WEBSITE, [HTTP://SUPPORT.AVAYA.COM/LICENSEINFO](http://support.avaya.com/licenseinfo) ARE APPLICABLE TO ANYONE WHO DOWNLOADS, USES AND/OR INSTALLS AVAYA SOFTWARE, PURCHASED FROM AVAYA INC., ANY AVAYA AFFILIATE, OR AN AUTHORIZED AVAYA RESELLER (AS APPLICABLE) UNDER A COMMERCIAL AGREEMENT WITH AVAYA OR AN AUTHORIZED AVAYA RESELLER. UNLESS OTHERWISE AGREED TO BY AVAYA IN WRITING, AVAYA DOES NOT EXTEND THIS LICENSE IF THE SOFTWARE WAS OBTAINED FROM ANYONE OTHER THAN AVAYA, AN AVAYA AFFILIATE OR AN AVAYA AUTHORIZED RESELLER, AND AVAYA RESERVES THE RIGHT TO TAKE LEGAL ACTION AGAINST YOU AND ANYONE ELSE USING OR SELLING THE SOFTWARE WITHOUT A LICENSE. BY INSTALLING, DOWNLOADING OR USING THE SOFTWARE, OR AUTHORIZING OTHERS TO DO SO, YOU, ON BEHALF OF YOURSELF AND THE ENTITY FOR WHOM YOU ARE INSTALLING, DOWNLOADING OR USING THE SOFTWARE (HEREINAFTER REFERRED TO INTERCHANGEABLY AS "YOU" AND "END USER"), AGREE TO THESE TERMS AND CONDITIONS AND CREATE A BINDING CONTRACT BETWEEN YOU AND AVAYA INC. OR THE APPLICABLE AVAYA AFFILIATE ("AVAYA").

Copyright

Except where expressly stated otherwise, no use should be made of the Documentation(s) and Product(s) provided by Avaya. All content in this documentation(s) and the product(s) provided by Avaya including the selection, arrangement and design of the content is owned either by Avaya or its licensors and is protected by copyright and other intellectual property laws including the sui generis rights relating to the protection of databases. You may not modify, copy, reproduce, republish, upload, post, transmit or distribute in any way any content, in whole or in part, including any code and software. Unauthorized reproduction, transmission, dissemination, storage, and or use without the express written consent of Avaya can be a criminal, as well as a civil offense under the applicable law.

Third Party Components

Certain software programs or portions thereof included in the Product may contain software distributed under third party agreements ("Third Party Components"), which may contain terms that expand or limit rights to use certain portions of the Product ("Third Party Terms"). Information regarding distributed Linux OS source code (for those Products that have distributed the Linux OS source code), and identifying the copyright holders of the Third Party Components and the Third Party Terms that apply to them is available on the Avaya Support Web site: <http://support.avaya.com/Copyright>.

Trademarks

The trademarks, logos and service marks ("Marks") displayed in this site, the documentation(s) and product(s) provided by Avaya are the registered or unregistered Marks of Avaya, its affiliates, or other third parties. Users are not permitted to use such Marks without prior written consent from Avaya or such third party which may own the Mark. Nothing contained in this site, the documentation(s) and product(s) should be construed as granting, by implication, estoppel, or otherwise, any license or right in and to the Marks without the express written permission of Avaya or the applicable third party. Avaya is a registered trademark of Avaya Inc. All non-Avaya trademarks are the property of their respective owners.

Downloading documents

For the most current versions of documentation, see the Avaya Support. Web site: <http://www.avaya.com/support>

Contact Avaya Support

Avaya provides a telephone number for you to use to report problems or to ask questions about your product. The support telephone number is 1-800-242-2121 in the United States. For additional support telephone numbers, see the Avaya Web site: <http://www.avaya.com/support>

Revision history

October 2010

Standard 07.01. This document is up-issued to support Unistim 5.0 and Avaya Communication Server 1000 Release 7.5.

June 2010

Standard 06.01. This document is up-issued to support Communication Server 1000 Release 7.0.

October 2009

Standard 05.01. Because of the similarity between Communication Server 1000 Release 6.0 for UNiStim 4.0 features and Release 5.5 features, UNiStim 4.0 Release 6.0 documentation is also used for Release 5.5.

June 2009

Standard 04.02. This document is up-issued to support Nortel Communication Server 1000 Release 6.0.

May 2009

Standard 04.01. This document is up-issued to support Nortel Communication Server 1000 Release 6.0.

April 2008

Standard 03.03. This document is up-issued to support Nortel Communication Server 1000 Release 5.5 for UNiStim 3.0.

May 2007

Standard 02.01. This document is issued to support Nortel Communication Server 1000 Release 5.0.

March 2007

Standard 01.01. This document is issued to support Communication Server 1000 Release 4.5. This is the first publication of this document.

Contents

About the Avaya 1110 IP Deskphone	11
Basic features	11
Telephone controls	13
Telephone display	17
License Notification	17
Call features and Flexible Feature Codes	18
Audio and text message broadcast	18
Security features	19
Using Encrypted Calling	19
Managing your Station Control Password (SCPW)	19
Entering and editing text	22
Entering text using the dialpad	22
Editing text using the soft keys	22
Entering text using the USB keyboard	24
Connect the components	25
Before you begin	25
Telephone features	31
Telephone Options	31
Volume adjustment... ..	33
Contrast adjustment	34
Language... ..	35
Date/Time... ..	36
Local Dialpad Tone	37
Set Info	37
Diagnostics	38

Ring type...	39
Call timer	40
Live Dial Pad	41
Caller ID display order	42
Normal mode indication	42
Local tools	44
1. Using the Preferences submenu	45
1. Contrast	46
2. Languages...	46
3. Backlight Timer	47
2. Using the Local Diagnostics submenu	48
1. IP Set&DHCP Information	49
2. Network Diagnostic Tools	49
3. Ethernet Statistics	49
4. IP Network Statistics	49
5. DHCP Information	50
6. License Information	50
7. Certificate Information	50
3. Using the Network Configuration submenu	50
4. Using the Lock Menu	50
Making a call	51
Using Off-hook dialing	51
Using On-hook Dialing	52
Using Predial	52
Using Ring Again	53
Using Last Number Redial	55
Using Speed Call	56
Using System Speed Call	57

Answering a call	58
While on an active call	58
Placing a call on hold	58
Transferring a call	59
Using Timed Reminder Recall	60
Using Call Park	61
Recording a Calling Party Number	63
Tracing a malicious call	64
While away from your desk	65
Using Call Forward	65
Using Internal Call Forward	66
Using Remote Call Forward	67
Securing your telephone	69
Talking with more than one person	71
Setting up a conference call	72
Using Group Call	73
Working without interruption	75
Activating Make Set Busy	75
Additional call features	76
Using Call Page Connect to make an announcement	76
Charging a call or charging a forced call	77
Using Enhanced Override	80
Using Forced Camp-on	81
Overriding a busy signal	83
Using Privacy Release	83
Using Radio Page	84

Additional phone features	87
Secure Communication	87
Using Virtual Office	87
Logging in to Virtual Office	89
Using Virtual Office on your Remote telephone	90
Using Virtual Office on your Office telephone	93
Logging out of Virtual Office	95
Automatic log out from Virtual Office	95
Emergency calls on your Remote IP Deskphone	95
Troubleshooting Virtual Office	96
Using Media Gateway 1000B	98
Using Test Local Mode	99
Using Resume Normal Mode	100
Troubleshooting MG 1000B	100
Using Hospitality features	102
Configuring Automatic Wake-Up	102
Station Control Password	104
Accessing External Server Applications	106
Flexible Feature Codes (FFC)	107
Quick Reference	109
Feature operation	109
Legend	110
Services and Telephone Options menus	110
Regulatory and safety information	113
Other	115
DenAn regulatory notice for Japan	115

Third party terms	117
Third Party Terms for UNIStim sw releases	
4.1 thru 5.0 (Jan 2010 - Nov 2010)	117
GNU	118
OpenSSL	125
Zlib	128
Curl	129
Libpng	130
Kern_random	132
ConvertUTF	133
Wchar functions	134
Libjpeg	135
Terms you should know	137
Index	143

About the Avaya 1110 IP Deskphone

The Avaya 1110 IP Deskphone brings voice and data to the desktop by connecting directly to a Local Area Network (LAN) through an Ethernet connection.

Basic features

Your Avaya 1110 IP Deskphone supports the following:

- four context-sensitive soft keys providing access to a maximum of 10 features

For information about context-sensitive soft keys, see *Avaya Features and Services Fundamentals (NN43001-106)*.

Context-sensitive soft keys are Avaya Communication Server dependent. Some Avaya 1110 IP Deskphones may not be configured to support context-sensitive soft key functionality. Contact your site administrator for further details.

- pixel-based LCD screen, backlit, with adjustable contrast
- speaker for on-hook listening and on-hook dialing
- volume control keys for adjusting ringer, speaker, and handset volume
- three call-processing fixed keys:
 - Line
 - Hold
 - Goodbye
- three specialized feature keys:
 - Message/Inbox
 - Services
 - Expand
- integrated 10/100 Ethernet switch for shared PC access

About the Avaya 1110 IP Deskphone

- automatic network configuration
- hearing aid compatibility

Note: Wideband audio is not supported on the Avaya 1110 IP Deskphone.

Note: Some features are not available on all telephones. Consult your system administrator to verify which features are available for your use.

Figure 1 shows the controls of your Avaya 1110 IP Deskphone.

Figure 1: Avaya 1110 IP Deskphone



Telephone controls

Table 1: Telephone controls

Note: In some geographic regions, the Avaya 1110 IP Deskphone is offered with key caps that have English text labels. Text in parentheses indicates labels appearing on the key caps, for example, (Services).



Context-sensitive soft keys are located below the LCD display area. The LCD label above each context-sensitive soft key changes based on the call state or active feature.



When a triangle appears before a context-sensitive soft key label, the feature associated with the context-sensitive soft key is active.

Press the **More** key to access the next layer of context-sensitive soft keys.

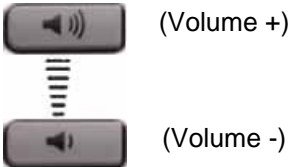

Use the **Volume control** buttons to adjust the volume of the ringer, handset and speaker. Press the top button to increase the volume, and press the bottom button to decrease volume.



Use the **Navigation** keys to scroll through menus and lists appearing on the LCD display screen. The outer part of this key cluster rocks for up, down, left, and right movements.



Press the **Enter** key, at the center of the Navigation key cluster, to confirm menu selections.

In many cases, you can use the **Enter** key instead of the **Select** context-sensitive soft key.



(Line)

Use the **Line (DN)** key to access the single line and activate on-hook dialing. No status icon or LED is provided.



(Hold)

Press the **Hold** key to put an active call on hold. Press the **Hold** key again to return to the caller on hold.



(Expand)

Use the **Expand** key to access external server applications.



(Goodbye)

Use the **Goodbye** key to terminate an active call.



When a message is waiting, the red **Visual Alerter/Message Waiting** indicator flashes. Also, when the ringer sounds, this indicator flashes. The flash cadence for each alert is different.

Note: You may also hear an audio Message Waiting Indicator (stutter or beeping dial tone) when you go off-hook.



When your Avaya 1110 IP Deskphone firmware is being updated, the blue **Feature Status Lamp** flashes.

Note: To find out if additional features are supported, contact your administrator.



(Services)

Press the **Services** key once to access the following server-based options:

- Telephone Options:
 - Volume adjustment...
 - Contrast adjustment
 - Language...
 - Date/Time...
 - Local Dialpad Tone
 - Set Info
 - Diagnostics
 - Ring type...
 - Call timer
 - Live Dial Pad
 - Caller ID display order
 - Normal mode indication
- Password Admin:
 - Station Control Password

Note: The **Password Admin** menu may not be available on all Avaya 1110 IP Deskphones. Consult your system administrator.

- Virtual Office Login and Virtual Office Logout (if Virtual Office is configured)
- Test Local Mode and Resume Local Mode (if Media Gateway 1000B is configured)

Note: Press the **Services** key to exit from any menu or menu item.



(Services)



(Services)

Press the **Services** key twice to access the following telephone-based (local) options:

- 1. Preferences
- 2. Local Diagnostics
- 3. Network Configuration
- 4. Lock Menu

Note 1: Access to these local options can be password protected. If you press the **Services** key twice and a password prompt appears, contact your system administrator.

Note 2: Press the **Cancel** context-sensitive soft key to exit from any menu or menu item.



(Msg/Inbox)

Press the **Message/Inbox** key to access your voice mailbox.

Note: This function may not be available on all Avaya 1110 IP Deskphones; consult your system administrator.

Telephone display

Table 1 shows the LCD screen of your Avaya 1110 IP Deskphone.

Figure 2: Avaya 1110 IP Deskphone LCD screen

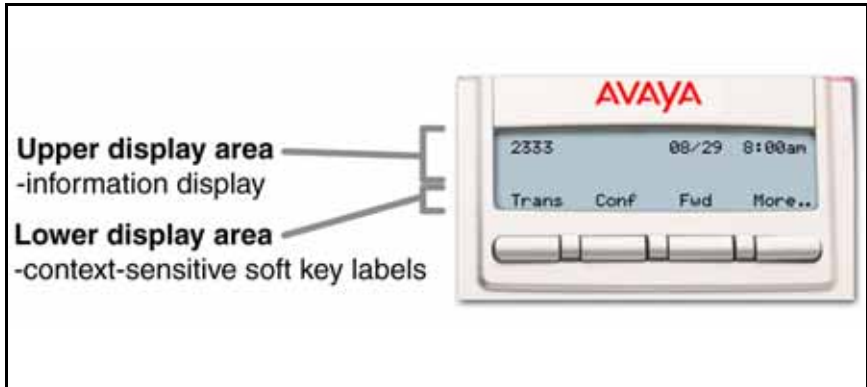

The LCD screen on your Avaya 1110 IP Deskphone consists of two basic display areas:

- The upper display area is for information such as caller number, caller name, feature prompt string, user-entered digits, date and time (or call timer, if provisioned in the Telephone Options menu), and telephone information.
- The lower display area is for context-sensitive soft key labels.

License Notification

Notify your system administrator if your IP Deskphone displays a message in a pop-up window about the licensing feature or evaluation period. License notification provides details to help diagnose why the features are disabled on the phone. You can press the Stop key or lift the handset to close the window. The window redisplay every 24 hours at 1:00 AM (default). The time and time frame can be configured when you provision the phone. For information about provisioning the IP Deskphones, see *Avaya Communication Server 1000 IP Deskphones Fundamentals* (NN43001-368).

Call features and Flexible Feature Codes

Some features are not available on all IP Deskphones. Call features and Flexible Feature Codes (FFCs) must be assigned to your IP Deskphone and supported by system software. Contact your system administrator to configure these features and codes on your IP Deskphone. Use table [“Flexible Feature Codes \(FFC\)” on page 107](#) to record the FFCs that your system administrator assigns to your phone.

Audio and text message broadcast

The Avaya 1110 IP Deskphone can display special messages in the display area of your telephone, and can play special audio messages through the speaker. Your administrator broadcasts these messages, which can be used to inform you of events like company news and weather bulletins. The message can be preceded by an audio alert (a series of beeps).

The Avaya 1110 IP Deskphone supports the following special messages:

- top line: up to three lines of text. The displays of the first two lines alternate; the third line displays continuously
- audio: an audio message streams to the telephone

When an audio message starts, the Interrupt Screen displays. While the audio message plays, you can switch to your handset or headset to listen to the message. Depending on the priority of the message, the message can barge-in during an active telephone call, during an incoming call alert, or when another message is playing.

You can also cancel the audio using the following methods:

- if listening on the speaker, pressing the Handsfree key
- if listening on the handset, placing the handset on hook
- if listening on the headset, pressing the Headset key
- by pressing the Cancel soft key
- by pressing any Line or Feature key

Security features

The following security features are available on your Avaya 1110 IP Deskphone:

- Using Encrypted Calling
- Connect the components

Using Encrypted Calling

Your Avaya 1110 IP Deskphone supports secure communication using SRTP media encryption. If the feature is enabled, a security icon (q) is displayed on the screen when your call is secured using SRTP media encryption. Contact your system administrator to find out if this feature is available for your use.

Managing your Station Control Password (SCPW)

Your Station Control Password (SCPW) enables the following security features:

- Electronic Lock to prevent others from making calls from your IP Deskphone
- Password-protected IP Deskphone features (for example, Personal Directory, Redial List, and Callers List)

Your system administrator defines your initial SCPW. Contact your system administrator for detailed information.

To change your password (SCPW):



(Services)

1. Press the **Services** key.



2. Press the **Up/Down** navigation keys to scroll up or down, and highlight **Password Admin**.



3. Press the **Enter** key.



4. Use the dialpad to enter your password at the prompt.



5. Press the **Up/Down** navigation keys to scroll up or down, and highlight **New Password**.



6. Press the **Enter** key.



7. Use the dialpad to enter the new password.



8. Press the **Enter** key to accept the new password.

If you are locked out of your Avaya 1110 IP Deskphone, or if you forget your SCPW, contact your system administrator.

Note: The default configuration for Password Protection is off.

To turn Password Protection on or off:



1. Press the **Directory** key.



2. Press the **Up/Down** navigation keys to scroll up or down, and highlight **Change Protection Mode**.



3. Use the dialpad to enter your password (if Password Protection is enabled).

Enter



4. Press the **Enter** soft key.



5. Press the **Up/Down** navigation keys to highlight one of the following:
 - Enable Password Protection
 - Disable Password Protection

Yes

No

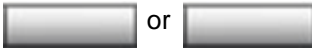

6. Choose one of the following soft keys:
 - **Yes** to accept the selection
 - **No** to return to the Directory menu

Done



7. Press the **Done** soft key.

Entering and editing text

You can enter and edit text on your Avaya 1110 IP Deskphone using the following methods:

- “Connect the components” on page 25
- “Editing text using the soft keys” on page 22
- “Connect the components” on page 25

The use of any of these methods for text entry depends on the application. Table 2 shows the applications and input devices that you can use for text entry.

Table 2: Application text entry

For:	Use:
Call Server-related applications (for example, changing feature key labels, adding personal directory entries, or dialing)	Dialpad USB keyboard for numeric entries only
Graphical applications	USB keyboard
Local Tools menu	USB keyboard Dialpad for numeric entries

Entering text using the dialpad

You can use the dialpad to enter text when you use features such as Personal Directory, Redial List, and Callers List.

For example, if you want to use the letter A, press the number **2** key once. If you want the letter C, press the number **2** key three times.

Note: No letters are associated with the number 1 or the 0 keys.

Editing text using the soft keys

You can use soft keys to edit text when you use features such as Personal Directory, Redial List, and Callers List.

To edit an entry in your Personal Directory, press the **Directory** key, and select the desired entry from your Personal Directory.

To edit text with the soft keys:

1. Press the **Edit** soft key.
2. Press the **Left/Right** navigation keys to move through the text.
3. Select the appropriate editing soft key for the operation you want to perform.
4. If the character you want is not visible, press the **More** soft key to access the next layer of soft keys.
5. To add non-alphanumeric symbols, press the **Symbol** soft key, and perform the following:
 - a. Press the **Up** navigation key to access the symbols.
 - b. Press the **Left/Right** navigation keys to move to a specific symbol.
 - c. Press the **Choose** soft key to select a symbol.
6. Press the **Next** soft key to submit your changes.

Table 3 describes the soft key editing functions on your Avaya 1110 IP Deskphone.

Table 3: Editing soft key description (Part 1 of 2)

Key	Description
Cancel	Action is cancelled.
Choose	Select a non-alphanumeric symbol (available only after the Symbol soft key is selected).
Clear	Clear the input field.
Case	Switch the next character to either uppercase or lowercase.
Delete	Backspace one character.

Table 3: Editing soft key description (Part 2 of 2)

Key	Description
Done/Select/Enter	Meaning depends on application.

Entering text using the USB keyboard

You can use the USB keyboard, when connected, to enter text in the tools and graphical applications.

For number entry in phone applications (for example, when dialing), you can use the keyboard to enter digits (0–9), as well as * and #. Other characters are ignored.

When on a call, you can use the function keys (f1, f2, f3, f4, f5, f6, f7, and f8) to control the phone. Table 4 shows the function keys and their associated action during phone calls.

Table 4: USB keyboard function keys during phone calls

Function key	Action
f1	Go to Handsfree mode
f2	Go to Headset mode
f3	Place the current call on hold
f4	Mute the current call
f5	Volume up
f6	Volume down
f7	Copy
f8	Quit

Connect the components

Before you begin

**CAUTION****Damage to Equipment**

Do not plug your Avaya 1110 IP Deskphone into a regular or ISDN telephone jack. This results in severe damage to the IP Deskphone. Consult your system administrator to ensure that you plug your phone into a 10/100BaseT Ethernet jack.

**CAUTION**

Your Avaya 1110 IP Deskphone is designed for use in an indoor environment only.

Figure 3: Release the phone from the stand

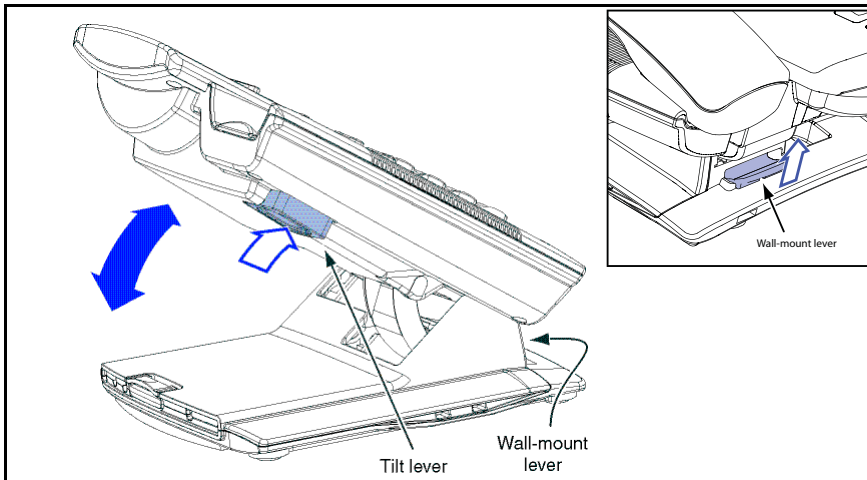

WARNING Your Avaya 1110 IP Deskphone is shipped with its stand locked in position. To release the phone from the stand, press the Wall-Mount lever (see [Figure 3](#)) and gently rotate the phone away from the stand a little. When you're sure the phone is released from the stand, press the Tilt lever and fully rotate the phone away from the stand.

Use the following steps to connect the components of your phone.

1. **Remove the stand cover.** Pull upward on the center catch (see [Figure 4](#)) and remove the stand cover from the stand base. The cable routing tracks are now accessible in the stand base (see [Figure 5](#)).

Figure 4: Remove the stand cover

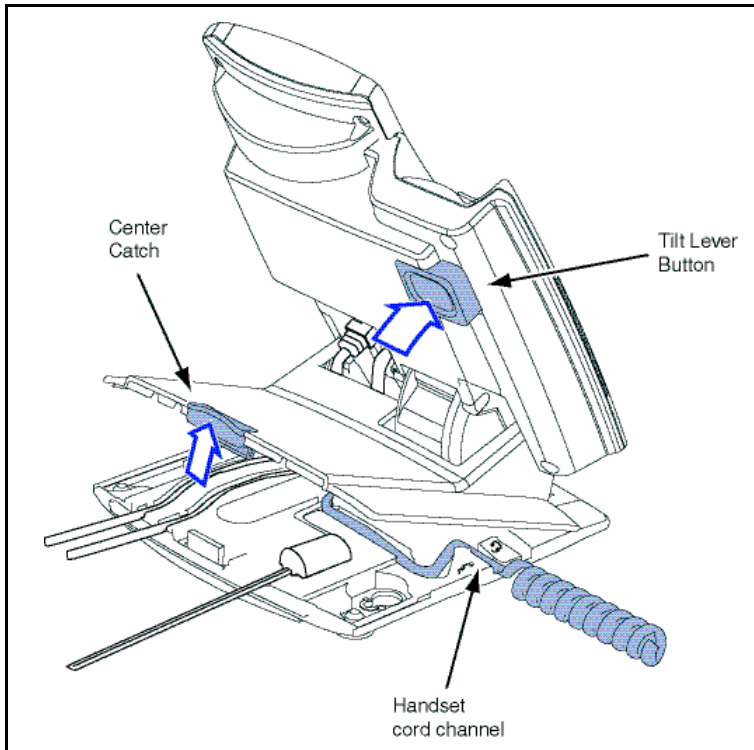

2. **Connect the AC power adapter (optional).** Connect the AC power adapter (not supplied) to the AC adapter jack in the bottom of the phone (see [Figure 5](#)). Form a small bend in the cable, and then thread the adapter cord through the channel in the stand base. Plug the AC power adapter into the nearest AC power outlet.

Note: Your Avaya 1110 IP Deskphone supports both AC power and Power over Ethernet (PoE), including IEEE 802.3af standard power. To use AC power, use only the Avaya-approved AC power adapter (RoHS Global Power Supply, PEC #: N0089601), which can be ordered separately. To use Power over Ethernet (PoE) power, your connected LAN must support PoE; an AC power adapter is not required.

Figure 5: Avaya 1110 IP Deskphone connections

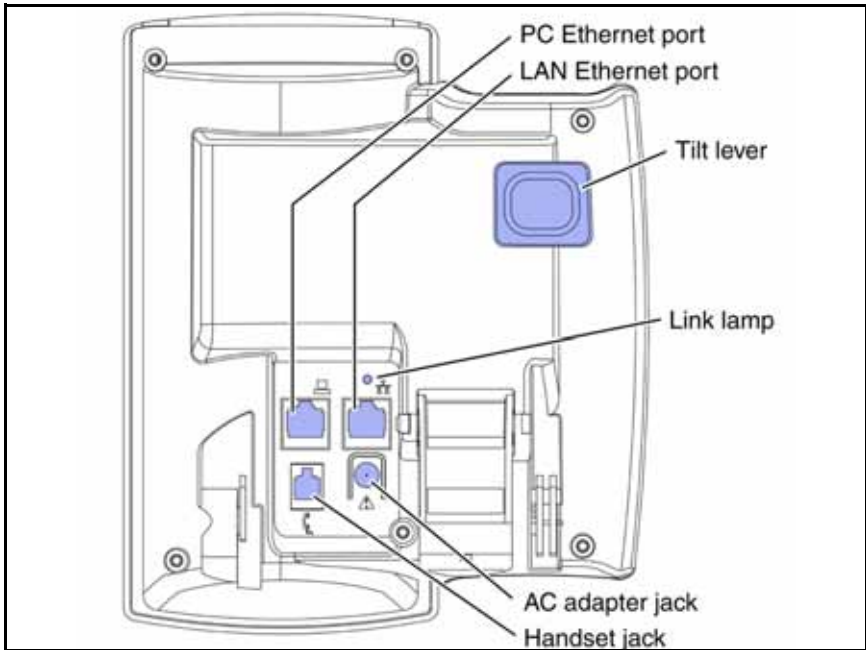

3. **Install the handset.** Plug the end of the handset cord with the short straight section into the handset. Plug the end of the handset cord with the long straight section into the handset jack on the back of the phone (see [Figure 5](#)) marked with the symbol +. Form a small bend in the cord, and then thread it through the channel in the stand base marked with the symbol + so that it exits in the handset cord channel on the right-hand side of the stand base (see [Figure 4](#)).
4. **Install the LAN Ethernet cable.** Plug one end of the supplied LAN Ethernet cable into the LAN ethernet port on the back of your phone (see [Figure 5](#)) marked with the symbol % and thread the cable through the channel in the stand base marked with the symbol %.
5. **Install the PC Ethernet cable (optional).** If you are connecting your PC Ethernet through the phone, plug one end of the PC Ethernet cable (not supplied) into the PC ethernet port on the back of your phone (see [Figure 5](#)) marked with the symbol (and thread the cable through the channel in the stand base marked with the symbol

(. Plug the other end of the cable into the LAN port on the back of your PC.

Figure 6: Cable routing tracks and mounting holes

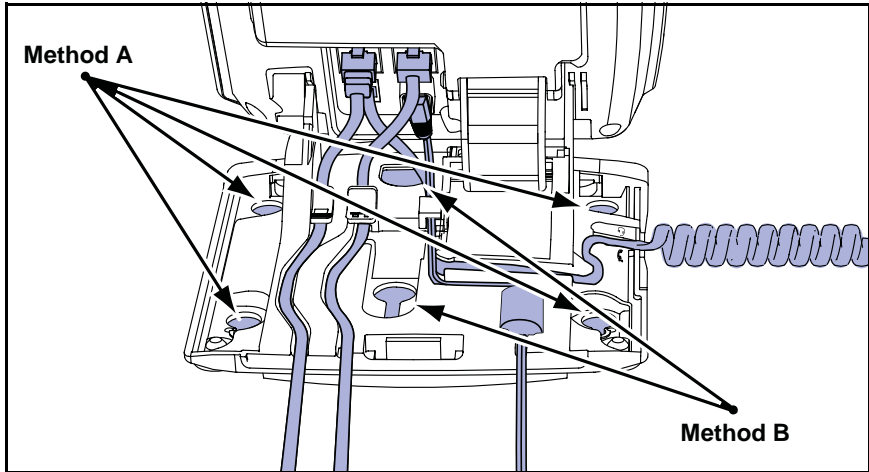

6. **Wall-mount your phone (optional).** Your Avaya 1110 IP Deskphone can be mounted either by: (Method A) using the mounting holes on the bottom of the phone stand, or (Method B) using a traditional-style wall-mount box with an RJ-45 connector and a 15-cm (6-inch) RJ-45 cord (not supplied).

Complete steps 1-5, as needed, before you wall-mount your phone:

Method A: Using the stand cover (part removed in step 1), mark the wall-mount holes by pressing the bottom of the stand cover firmly against the wall in the location where you wish to install the phone. Four small pins on the bottom of the stand cover make marks on the wall. Use the marks as a guideline for installing the wall-mount screws (not supplied). Install the screws so that they protrude 3 mm (1/8 inch) from the wall, and then position the phone stand mounting holes (as shown in Figure 6, Method A) over the screw heads. You may need to remove the phone from the wall to adjust the lower screws. When the lower screws fit snugly, tighten the top screws.

Method B: Attach the 15-cm (6-inch) CAT5e cable (not supplied), position the phone stand mounting holes (shown in Figure 6, Method B) over the mounting rivets, push the phone onto the mounting rivets and down, to lock the phone into position.

7. **Replace the stand cover.** Ensure that all cables are neatly routed and press the stand cover into place until you hear an audible click.
8. **Put the phone in the wall-mount position.** If you wall-mounted your phone, put it in the wall-mount position by pressing the Tilt Lever and pushing the phone towards the stand until the phone is nearly parallel with the stand. Release the Tilt Lever and continue to gently push the phone towards the stand until you hear an audible click (from the Wall-Mount lever). Ensure the phone is securely locked in position.

Telephone features

Your Avaya 1110 IP Deskphone has both server-based telephone features and local (telephone-based) tools. Server-based telephone features are accessed through the **Telephone Options** menu item on the **Services** menu. Press the **Services** key once to access the **Services** menu, which has the following menu items:

- **Telephone Options**
 - enables you or your system administrator to select and configure server-based telephone features. For more information, see **Telephone Options** below.
- **Password Admin**
 - enables you or your system administrator to manage the Station Control Password (SCPW). For more information, see **Station Control Password** on page 104.
- **Virtual Office Login** and **Test Local Mode** (for Branch Office)
 - are present only when your phone's Class of Service is configured for Virtual Office and Branch Office. For more information, see **"Using Virtual Office" on page 87**.

Note: The **Password Admin**, **Virtual Office Login**, and **Test Local Mode** menus are not available on all Avaya 1110 IP Deskphone telephones. Consult your system administrator.

Telephone Options

The **Telephone Options** menu item provides you with access to the following features on your Avaya 1110 IP Deskphone:

- **"Volume adjustment..." on page 33**
- **"Contrast adjustment" on page 34**
- **"Language..." on page 35**
- **"Date/Time..." on page 36**
- **"Local Dialpad Tone" on page 37**

- “Set Info” on page 37
- “Diagnostics” on page 38
- “Ring type...” on page 39
- “Call timer” on page 40
- “Live Dial Pad” on page 41
- “Caller ID display order” on page 42
- “Normal mode indication” on page 42

When an option has a submenu, an ellipses (...) appears after the option.

Using the Telephone Options menu:



1. Press the **Services** key.



2. Press the **Up/Down** navigation keys to scroll up or down, and then locate **Telephone Options**.



3. Press the **Enter** key.



1. Use Press the **Up/Down** navigation keys to scroll up or down, and then locate an option (for example, **Contrast adjustment**).



2. Press the **Enter** key. The display provides information required to adjust your selection.

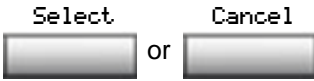

3. Choose one of the following:
 - Press the **Select** context-sensitive soft key to save any changes and return to the **Telephone Options** menu.
 - Press the **Cancel** context-sensitive soft key to keep existing setting and return to the **Telephone Options** menu.

Volume adjustment...

To adjust the volume, press the **Services** key, select **Telephone Options**, and then select **Volume adjustment...**

Adjusting the volume:



1. Press the **Up/Down** navigation keys to scroll up or down, and then locate one of the following items:
 - **Ringer**
 - **Handset listen**
 - **On-Hook listening/dialing**



2. Press the **Enter** key.

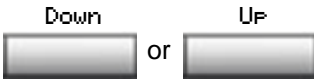

or

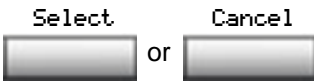

3. To increase or decrease the volume, do one of the following:

- Press the **Up** or **Down** context-sensitive soft keys.
- Press the **Up** or **Down** navigation keys.

4. Choose one of the following:

- Press the **Select** context-sensitive soft key to save the volume level and return to the **Telephone Options** menu.
- Press the **Cancel** context-sensitive soft key to keep existing configurations.

Contrast adjustment

To adjust the LCD display screen contrast, press the **Services** key, select **Telephone Options**, and then select **Contrast adjustment**.

Adjusting the display screen contrast:

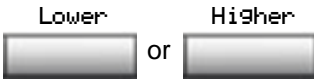

or



1. To increase or decrease the display contrast level, choose one of the following:

- Press the **Lower** or **Higher** context-sensitive soft keys.
- Press the **Up** or **Down** navigation keys.



2. Choose one of the following:

- Press the **Select** context-sensitive soft key to save the contrast level and return to the **Telephone Options** menu.
- Press the **Cancel** context-sensitive soft key to keep existing configurations.

Language...

The LCD display is available in multiple languages. To choose a language, press the **Services** key, select **Telephone Options**, and select **Language...**

If the Language setting is password-protected, you must enter a password (SCPW) to change the language. If you enter an incorrect password, an error message is displayed. If you enter an incorrect password more than three times, the password functionality is locked. Contact your system administrator to unlock the password.

Selecting a language:



1. Press the **Up/Down** navigation keys to scroll up or down, and then highlight the desired language (for example, German [Deutsche]).



2. Choose one of the following:
 - Press the **Select** context-sensitive soft key to save the language and return to the **Telephone Options** menu.
 - Press the **Cancel** context-sensitive soft key to keep existing configurations.

Date/Time...

Several date and time formats are available. Formats are based on the 12-hour and 24-hour clocks. To select the date and time format, press the **Services** key, select **Telephone Options**, and then select **Date/Time...**

Selecting a date and time format:



1. Press the **Up/Down** navigation keys to scroll up or down, and then highlight the desired format. Sample formats appear on the upper-right side of the display area.



2. Choose one of the following:
 - Press the **Select** context-sensitive soft key to save the format and return to the **Telephone Options** menu.
 - Press the **Cancel** context-sensitive soft key to keep existing configurations.

Local Dialpad Tone

The Local DialPad Tone option produces Dual-Tone Multi-Frequency (DTMF) sounds, a single tone, or no sound when you press a key on the dialpad. To choose a local dialpad tone, press the **Services** key, select **Telephone Options**, and then select **Local DialPad Tone**.

Choosing a local dialpad tone:



1. Press the **Up/Down** navigation keys to highlight one of the following dialpad tones:
 - **None** to disable all tones
 - **Short Click** to enable a single tone for all keys
 - **DTMF** to turn on a separate DTMF tone for each key

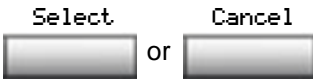

2. Choose one of the following:
 - Press the **Select** context-sensitive soft key to save the tone selection and return to the **Telephone Options** menu.
 - Press the **Cancel** context-sensitive soft key to keep existing configurations.

Set Info

The Set Info option displays the following telephone-specific information:

- General Info
- Set IP Info
- Ethernet Info

- Server Info
- Location Info
- Encryption Info

To view telephone-specific information, press the **Services** key, select **Telephone Options**, and then select **Set Info**.

Viewing telephone-specific information:



1. Press the **Up/Down** navigation keys to scroll through the list to view the telephone information.
2. Press the **Cancel** context-sensitive soft key to return to the **Telephone Options** menu.

Diagnostics

The Diagnostics option displays the following telephone-specific information:

- Diag Tools (Ping, do Route Traces)
- EtherStats (Speed, Auto Neg, CRC Errors, Collision)
- IP Stats (Packet Info)
- RUDP Stats (Msg receive/trans)
- QOS Stats
- DHCP Info

To view diagnostic information, press the **Services** key, select **Telephone Options**, and select **Diagnostics**.

Viewing telephone-specific diagnostic information:



Cancel



1. Press the **Up/Down** navigation keys to scroll through the list of diagnostic information.
2. Press the **Cancel** context-sensitive soft key to return to the **Telephone Options** menu.

Ring type...

The Ring type... option configures the telephone's ring tone. To choose a ring type, press the **Services** key, select **Telephone Options**, and then select **Ring type...**

Choosing a ring type:



Play



1. Press the **Up/Down** navigation keys to scroll up or down, and then highlight one of the ring types.
2. Press the **Play** context-sensitive soft key to sample the ring tone.



3. Choose one of the following:
 - Press the **Select** context-sensitive soft key to save the ring type and return to the **Telephone Options** menu.
 - Press the **Stop** context-sensitive soft key, and then use the **Up/Down** navigation keys to select a different ring type.
 - Press the **Cancel** context-sensitive soft key to keep existing configurations.

Call timer

The call timer measures how long you are on each call. To enable Call timer, press the **Services** key, select **Telephone Options**, and then select **Call timer**.

Enabling or disabling Call Timer:

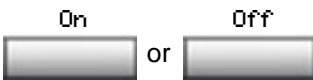

1. Choose one of the following:
 - To turn on the call timer, press the **On** context-sensitive soft key.
 - To turn off the call timer, press the **Off** context-sensitive soft key.

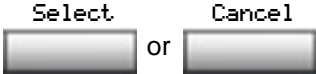
- Select or Cancel
- 
2. Choose one of the following:
- Press the **Select** context-sensitive soft key to save the configuration and return to the **Telephone Options** menu.
 - Press the **Cancel** context-sensitive soft key to keep existing configurations.

Live Dial Pad

Use Live Dialpad to dial a number using the telephone keypad without having to pick up the handset, press the **Handsfree** key, or press the **Line (DN)** key.

Note: Live Dialpad activates the primary DN key.

Configuring Live Dialpad

To configure Live Dialpad, press the **Services** key, select **Telephone Options**, and then select **Live Dial Pad**



1. Press the **Up/Down** navigation keys to scroll up or down, and then highlight one of the following:

- **On**
- **Off**

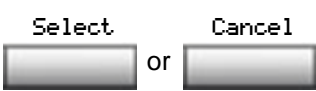
- Select or Cancel
- 
2. Choose one of the following:
- Press the **Select** soft key to save the configuration.
 - Press the **Cancel** soft key to keep existing configurations.

Caller ID display order

Caller ID display order appears in 2 formats:

- Number, name (default)
- Name, Number

Configuring Caller ID display order

Use the following procedure to configure Caller ID display order.

1. Press the **Services** key, select **Telephone Options**, and then select **Caller ID** display order.
2. Press the **Up/Down** navigation keys to scroll up or down, and then select one of the following:
 - **Number, name** (default)
 - **Name, number**
3. Press the **Select** soft key to save the configuration, else press the **Cancel** key to cancel the modifications.

Normal mode indication

The **Normal** mode display indication can be On or Off when the IP Deskphone is in normal mode.

Configuring Normal mode indication

Use the following procedure to configure Normal mode indication.

1. Press the **Services** key, select **Telephone Options**, and then select **Normal mode** indication.
2. Press the **Up/Down** navigation keys to scroll up or down, and then select one of the following:
 - **On**
 - **Off**
3. Press the **Select** soft key to save the configuration, else press the **Cancel** key to cancel the modifications.

Local tools

Your Avaya 1110 IP Deskphone has both local and server-based telephone tools and features. This section discusses the various tools and features available locally on your Avaya 1110 IP Deskphone. Many of the tools and features discussed in this section are for administrator use only. Do not make any changes unless instructed by an administrator.

Local tools and features are accessed through the **Local tools** menu. Press the **Services** key twice to access this menu. Your system administrator can establish a password for the **Local tools** menu. When the password is enabled, a password prompt appears when you attempt to access this menu. Use the dial pad to type the correct password, and then press the **Enter** key. The **Local tools** menu appears. If the menu does not appear, contact your system administrator.

The **Local tools** menu has the following menu options:

- “1. Using the Preferences submenu” on page 45
- “2. Using the Local Diagnostics submenu” on page 48
- “3. Using the Network Configuration submenu” on page 50
- “4. Using the Lock Menu” on page 50

Local tools menu options are preceded by numbers. Pressing the associated number key on the dialpad triggers the corresponding feature or tool. For example, when you are in the **Local tools** menu, you can select the **Local Diagnostics** menu option by pressing the 2 key on the dialpad.

The functions of some navigation keys on your Avaya 1110 IP Deskphone vary depending on the situation. The navigation controls for menus are described in **Table 5**

Table 5: Navigation controls for menus (Part 1 of 2)

Key	Function
Down arrow keys	Display next menu item.
Up arrow keys	Display previous menu item.

Table 5: Navigation controls for menus (Part 2 of 2)

Key	Function
Left arrow key	Close the menu.
Right arrow key	Select the current menu item.
Enter key	Select the current menu item.
Enter digit on the dialpad	Select correspondingly numbered menu item.
Cancel context-sensitive soft key	Exit the Local tools menu option or feature/tool.

When you are working in Edit mode, the first field of the item is highlighted and a blinking cursor is to the right of the current edit position. The navigation controls for Edit mode are described in [Table 6](#).

Table 6: Navigation controls for Edit mode

Key	Function
Left arrow key	Delete a character in the edit field.
Enter key	Ends editing function.
Enter digit on the dialpad	Inserts digits at current position
Asterisk (*)	Enters a dot (".") at current position.

1. Using the Preferences submenu

When you select the **Preferences** option from the Local tools menu, a **Preferences** submenu appears. This submenu provides access to tools used for controlling various local display preferences for your Avaya 1110 IP Deskphone.

The Preferences submenu provides access to the following tools:

- “1. Contrast” on page 46

- “2. Languages...” on page 46
- “3. Backlight Timer” on page 47

1. Contrast

Use the **Contrast** tool to adjust the contrast of the LCD display screen on your Avaya 1110 IP Deskphone.

To adjust the contrast of the LCD display screen, press the **Services** key twice to open the **Local tools** menu, press the 1 key on the dialpad to select the **Preferences** menu option, and then press the 1 key on the dialpad to select the **Contrast** tool from the **Preferences** submenu.

Note: The initial contrast setting for the LCD display screen is downloaded from the server when your telephone is first configured by your system administrator. Selecting the **Contrast** tool from the **Preferences** submenu in **Local tools** automatically sets the LCD display screen contrast to the telephone’s local contrast setting, even if the **Cancel** context-sensitive soft key is pressed.

Adjusting the LCD display screen contrast:



1. Press the **Up/Down** arrow keys to increase or decrease the value for the display screen contrast.



2. Press the **Enter** key to select the currently displayed value and exits the menu.



3. Press the **Cancel** context-sensitive soft key to exit the menu with no change.

2. Languages...

Use the **Languages...** tool to select the language used locally on your Avaya 1110 IP Deskphone.

Note: The **Telephone Options** menu is synchronized with the selected language.

To access the local language tool, press the **Services** key twice to open the **Local tools** menu, press the 1 key on the dialpad to select the **Preferences** menu option, and then press the 2 key on the dialpad to select the **Languages...** tool from the **Preferences** menu.

Selecting a local tools language:



1. Press the **Up/Down** navigation keys to scroll up or down, and then highlight the desired language (for example, German [Deutsche]).



1. Press the **Enter** key to select the desired language and exit the menu.

Cancel



2. Press the **Cancel** context-sensitive soft key to exit the menu with no change.

3. Backlight Timer

Use the **Backlight Timer** tool to adjust how long the LCD display screen remains lit when your phone is inactive.

To access the **Backlight Timer** tool, press the **Services** key twice to open the **Local tools** menu, press the 3 key on the dialpad to select the **Preferences** menu option, and then press the 1 key on the dialpad to select the **Backlight Timer** tool from the **Preferences** menu.

Note: The backlight timer is displayed in the format xxx, where xxx is a time in minutes or hours.

Adjusting the Backlight Timer:



1. Press the **Up/Down** arrow keys to increase or decrease the backlight timer.
 - Available values for the backlight timer are as follows:
 - 5m (5 minutes)
 - 15m (15 minutes)
 - 30m (30 minutes)
 - 1h (1 hour — default)
 - 2h (2 hours)
 - Never (screen does not go black)
 - Choosing a high backlight timer value or Never, reduces the life span of the display screen.



2. Press the **Enter** key to select the desired backlight timer value and exit the menu.



3. Press the **Cancel** context-sensitive soft key to exit the menu with no change.

2. Using the Local Diagnostics submenu

When you select the **Local Diagnostics** option from the Local tools menu, a **Local Diagnostics** submenu appears. This submenu provides access to tools used for monitoring and controlling the operation of your Avaya 1110 IP Deskphone.

The **Local Diagnostics** submenu provides access to the following tools:

- “1. IP Set&DHCP Information” on page 49

- “2. Network Diagnostic Tools” on page 49
- “3. Ethernet Statistics” on page 49
- “4. IP Network Statistics” on page 49
- “5. DHCP Information” on page 50
- “6. License Information” on page 50
- “7. Certificate Information” on page 50

When in the submenu, press the **Cancel** context sensitive soft key to exit the menu. When a Local Diagnostics tool is selected, use the Return context-sensitive soft key to exit the tool and return to the Local Diagnostics submenu.

Use the **Return** context-sensitive soft key to quickly gather information and run tests. For example, you can check **Ethernet Statistics** (submenu option 3), press the **Return** context-sensitive soft key to return to the **Local Diagnostics** submenu, and then select **Network Diagnostic Tools** (submenu option 2) to ping an IP address.

1. IP Set&DHCP Information

The system administrator can use the **IP Set&DHCP** tool to view reports about IP set and DHCP operation.

2. Network Diagnostic Tools

The system administrator can use the tools of **Network Diagnostic Tools** menu to diagnose network problems.

3. Ethernet Statistics

The system administrator can use the **Ethernet Statistics** tool to view reports about Ethernet operation.

4. IP Network Statistics

The system administrator can use the **IP Networks Statistics** tool to view reports about network operation.

5. DHCP Information

The system administrator can use the **DHCP Information** menu to view DHCP related information.

6. License Information

The system administrator can use the **License Information** menu to view license related information.

7. Certificate Information

The system administrator can use the Certificate Information to view certificate related information.

3. Using the Network Configuration submenu

When you select the **Network Configuration** option from the **Local tools** menu, network configuration data appears for your Avaya 1110 IP Deskphone. This tool is for administrator use only.

4. Using the Lock Menu

When you select the **Lock Menu** option from the **Local tools** menu, a Lock Menu submenu appears. This submenu provides access to tools used for controlling access to the **Local tools** menu itself or various **Local tools** menu options. This tool is for administrator use only.

Making a call

This section describes features associated with making a call. You can make a call from your Avaya 1110 IP Deskphone using any of the following methods:

- “Using Off-hook dialing” on page 51
- “Using On-hook Dialing” on page 52
- “Using Redial” on page 52
- “Using Ring Again” on page 53
- “Using Last Number Redial” on page 55
- “Using Speed Call” on page 56
- “Using System Speed Call” on page 57

Using Off-hook dialing



1. Lift the handset.



2. Dial the number.



or



(Goodbye)

3. To terminate the call, choose one of the following:
- Replace the handset into the cradle.
 - Press the **Goodbye** key.

Using On-hook Dialing

1. Leave the handset in the cradle.



2. Press the line (DN) key.



3. When the dial tone sounds, dial the number.



4. When the called party answers, lift the handset.



or



(Goodbye)

5. To terminate the call, choose one of the following:
 - Replace the handset into the cradle.
 - Press the **Goodbye** key.

Using Predial

Use the Predial feature to enter, preview, and edit numbers before dialing.

To use Predial:



1. Without selecting the line key, enter the number to be dialed.



or



2. Choose one of the following:
 - Lift the handset to dial the number.
 - Press the line key (DN) to dial the number.
3. If the Line key is used to dial the number, lift the handset when the called party answers.

To edit a Predial number:



Clear



or

Delete



1. Use the dialpad to enter the number.
2. Choose one of the following:
 - To erase all numbers, press the **Clear** context-sensitive soft key. Reenter the numbers to be dialed.
 - To change one number at a time, press the **Delete** context-sensitive soft key to backspace. Re-enter the number.
3. Press the line key to dial the number.



Using Ring Again

Use the Ring Again feature if you receive a busy tone or if there is no answer. Your IP Deskphone rings when the person you called becomes available. Ring Again automatically redials the number.

To activate Ring Again:

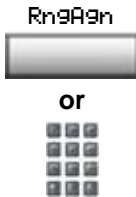

1. Dial a number and receive a busy tone or no answer.
2. Choose one of the following:
 - Press the **Ring Again** context-sensitive soft key.
 - Enter the **Ring Again Activate** FFC.

To call a Ring Again party when you receive notification:



1. After receiving the notification ring, lift the handset.
2. Press the **Ring Again** context-sensitive soft key to automatically dial the number.

To deactivate Ring Again before notification:

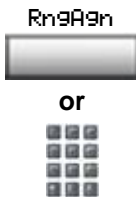

Choose one of the following:

- Press the **Ring Again** context-sensitive soft key a second time.
- Enter the **Ring Again Deactivate** FFC.

Using Last Number Redial

Use the Last Number Redial feature to automatically redial the last dialed number.

To use Last Number Redial:

Choose one of the following:



1. To redial using the handset:
 - Lift the handset.
 - Press the line (DN) key.



2. To redial without lifting the handset, press the line (DN) key twice (the last number dialed is automatically redialed).

Using Speed Call

Use the Speed Call feature to place internal and external calls by dialing a one-, two-, or three-digit code to store, edit, and automatically dial frequently called telephone numbers.

To store a Speed Call number:

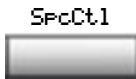

1. Press the **Speed Call Controller** context-sensitive soft key. The triangular icon flashes, indicating programming mode.



2. At the prompt:
 - Enter a one-, two-, or three-digit code (0-999).
 - If required, dial the access code.
 - Enter the telephone number (internal, external or long-distance number).

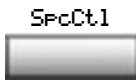

3. Press the **Speed Call Controller** context-sensitive soft key again to save the code and number. The flashing icon turns off.

To make a Speed Call:



1. Lift the handset.

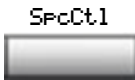

2. Press the **Speed Call Controller** context-sensitive soft key.



3. Dial the **Speed Call** code to automatically dial the number.

Using System Speed Call

Use the System Speed Call feature to dial Speed Call codes that override dialing restrictions placed on your telephone.

To make a System Speed Call:



1. Lift the handset.



2. Choose one of the following:
 - Press the **System Speed Call** context-sensitive soft key.
 - Press the **System Speed Call Controller (SScCt1)** key.



3. Dial the **Speed Call** code to automatically dial the number.

Answering a call

Each incoming call causes the telephone to ring and the Message Indicator lamp to flash.

To answer a call:



Lift the handset.

Note: Do not use the Line (DN) key to answer a call.

While on an active call

This section describes the following features, available during an active call:

- [“Placing a call on hold” on page 58](#)
- [“Transferring a call” on page 59](#)
- [“Using Timed Reminder Recall” on page 60](#)
- [“Using Call Park” on page 61](#)
- [“Recording a Calling Party Number” on page 63](#)
- [“Tracing a malicious call” on page 64](#)

Placing a call on hold

Use the Hold feature to place an active call on hold.

To place a call on hold:



(Hold)

Press the **Hold** key.

To retrieve a call on hold:



Press the line (DN) key.

Transferring a call

Use the Transfer feature to redirect a call to the appropriate person.

To transfer a call to a third party:



1. Press the **Transfer** context-sensitive soft key. The other party is put on hold and a dial tone sounds.



2. Dial the DN to which you are transferring the call.



3. When that number rings or a person answers, press the **Transfer** context-sensitive soft key to connect the calling party.

To return to the original call, if the transfer is incomplete:



If the person called is not available, press the **Line** (DN) key to reconnect to the original call.

Using Timed Reminder Recall

Use the Timed Reminder Recall feature to receive a reminder tone when a transferred call is not answered.

To use Timed Reminder Recall:

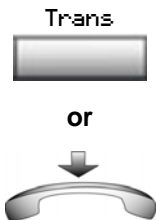

1. Press the **Transfer** context-sensitive soft key. The call is put on hold.
2. Dial the number to which you are transferring the call.
3. Choose one of the following to start the recall timer:
 - Press the **Transfer** context-sensitive soft key.
 - Replace the handset before the extension answers.

Note: If the transfer is complete, the recall timer stops.

If the transferred call is not answered, your telephone rings:



1. Lift the handset to reconnect to the original caller.

Trans



or



(Goodbye)

2. Choose one of the following:
 - Press the **Transfer** context-sensitive soft key and repeat the transfer.
 - If the transfer is picked up while you are on the line, press the **Goodbye** key to complete the transfer.

Using Call Park

Use the Call Park feature to hold temporarily (park) and retrieve a call from any telephone. Using Call Park does not tie up a line. When configured network-wide, Call Park can be used across networks. A System Park extension can be configured to automatically park most calls.

To park a call on the System Park DN or your own DN:

Park



Park



During an active call, press the **Park** context-sensitive soft key twice.

Note: By default, the call is parked on your DN unless a **System Park DN** is enabled to automatically park calls on the system.

To park a call on a DN other than the **System Park DN** or your own DN:



1. Press the **Park** context-sensitive soft key.



2. Dial the DN where you want to park the call.



3. Press the **Park** context-sensitive soft key.

To park a call using the **SPRE code** or **FFC**:

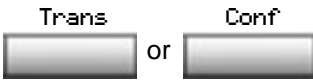

1. Choose one of the following:
 - Press the **Transfer** context-sensitive soft key.
 - Press the **Conference** context-sensitive soft key.



2. Dial the **Call Park** FFC.



3. To use an alternate DN from the **System Park** DN or your own DN, dial the DN where you want to park the call. Otherwise, proceed to step 4.



4. Choose one of the following:
 - Press the **Transfer** context-sensitive soft key.
 - Press the **Conference** context-sensitive soft key.

To retrieve a parked call:



1. Lift the handset.
2. Press the **Park** context-sensitive soft key.
3. Dial the DN where you parked the call.

Note: If a parked call is not retrieved within a specified period of time, it rings back to your telephone.

Recording a Calling Party Number

Use the Calling Party Number feature to record a caller's number, or to charge a call to an account number, during an established call.

To record a caller's number for accounting purposes:



1. Press the **Call Party** context-sensitive soft key. The caller is placed on hold.



2. Dial a charge account number or the caller's number.

Note: For information on using the **Charge** key, see “Charging a call or charging a forced call” on page 77.

CParty



3. Press the **Call Party** context-sensitive soft key to return to the call.

Tracing a malicious call

Use the Call Trace feature to trace nuisance calls within your system.

Note: This is not a default feature. Contact your system administrator to configure this feature on your telephone.

To activate Call Trace:

Trans



or

Conf



1. Choose one of the following:
 - Press the **Transfer** context-sensitive soft key.
 - Press the **Conference** context-sensitive soft key.



2. Dial the **SPRE code** followed by **83** or dial the **Call Trace** FFC to automatically reconnect.

Note: Contact your system administrator for the Call Trace feature SPRE code.

While away from your desk

You can use the following features when you are away from your desk:

- “Using Call Forward” on page 65
- “Using Internal Call Forward” on page 66
- “Using Remote Call Forward” on page 67
- “Securing your telephone” on page 69

Using Call Forward

Use the Call Forward feature to direct incoming calls to ring on another line (DN). If the telephone is ringing, the call cannot be forwarded.

To forward your calls or change the forward number:

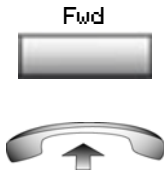

1. Choose one of the following:
 - Press the **Forward** context-sensitive soft key.
 - Lift the handset and enter the **Call Forward All Calls Activate** FFC.



2. Dial the DN where you want to forward your calls.



3. Press the **Forward** context-sensitive soft key.

To deactivate Call Forward:

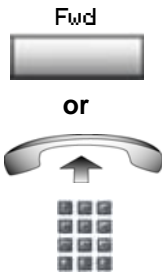

Choose one of the following:

- Press the **Forward** context-sensitive soft key.
- Lift the handset and enter the **Call Forward All Calls Deactivate** FFC.

To reinstate Call Forward to the same number:



Press the **Forward** context-sensitive soft key twice.

Using Internal Call Forward

Use Internal Call Forward to accept only calls originating at internal DNs to ring at another DN. Calls originating outside your telephone system still ring at your telephone. Current incoming calls cannot be forwarded.

To forward internal calls:

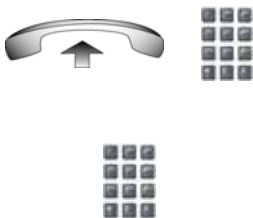

1. Lift the handset and enter the **Internal Call Forward Activate** FFC.
2. Dial the DN to which you are forwarding your internal calls.



3. Return the handset to the handset cradle.

To deactivate Internal Call Forward:



Lift the handset and enter the **Internal Call Forward Deactivate** FFC.

Using Remote Call Forward

Use the Remote Call Forward feature (from any telephone other than your own) to forward calls to any telephone.

To activate Remote Call Forward:



1. Lift the handset.



2. If you are calling from a telephone outside the system, dial your direct system access number and wait for the dial tone.



3. Dial the **Remote Call Forward Activate** FFC to activate the feature.



4. Dial your **Station Control Password**. A dial tone sounds.



5. Choose one of the following:
 - Dial your DN.
 - To forward calls to the previous call forward telephone number, press the # key. (Do not perform steps 6 and 7.)



6. Dial the number to which you are forwarding calls. If calls are forwarded to an invalid number, a fast busy signal sounds.



7. Press the # key.

To deactivate Remote Call Forward:



1. Lift the handset.



2. If you are calling from a telephone outside the system, dial the **direct system access** number and wait for the dial tone.



3. Dial the **Remote Call Forward Deactivate** FFC.



4. Dial your **Station Control Password**.



5. After you hear the dial tone, dial your DN.



6. Press the # key.

Securing your telephone

Use the Electronic Lock feature to prevent others from making calls from your telephone. The Electronic Lock feature is controlled using the corresponding Flexible Feature Codes (FFC) and your Station Control Password (SCPW).

To lock your telephone:



1. Lift the handset.



2. Dial the **Electronic Lock Activate** Flexible Feature Code (FFC).



3. Dial your **Station Control Password**.



(Goodbye)

or



4. Choose one of the following:
 - If you are dialing locally, press the **Goodbye** key.
 - If you are dialing the FFC remotely, dial your DN.

To unlock your telephone:



1. Lift the handset.



2. Dial the **Electronic Lock Deactivate FFC**.



3. Dial your **Station Control Password**.



(Goodbye)

or



4. Choose one of the following:

- If you are dialing locally, press the **Goodbye** key.
- If you are dialing the FFC remotely, dial your DN.

Talking with more than one person

Use the following features to enable conversations between more than two people:

- [“Setting up a conference call” on page 72](#)
- [“Using Group Call” on page 73](#)

Setting up a conference call

Use the Conference feature to set up a conference call for a maximum of three or six people including yourself. The maximum number of people the conference feature supports depends on the configuration of your telephone.

To set up a conference call:



1. While on a call, press the **Conference** context-sensitive soft key to place the party on hold. You hear a dial tone.



2. Dial the number of the person you want to add to the conference call. You can talk privately to the person you are adding at this time.



3. Press the **Conference** context-sensitive soft key a second time to conference all parties together.

If the person you attempt to add to the conference is unavailable:



(Goodbye)

1. Press the **Goodbye** key.



2. Press the line (DN) key to return to your original call.

Using Group Call

Use the Group Call feature to automatically call members of a predefined group, one at a time, until all members answer.

To call group members:



1. Lift the handset.



2. Enter the **Group Call FFC**.
 - The feature automatically calls all group members.
 - The telephone numbers of the group members appear on the display as they answer.

Note 1: After everyone in the group has answered, only the person who made the group call can put the call on hold.

Note 2: When a person in your group is on a conference call or another group call, they are not connected to your group call.

To answer a group call:



1. Lift the handset. Note the following about notification tones:
 - If you are on a call and receive three 10-second tones, this is the notification of a group call on your current extension.
 - If you are on a call on another line when a group call is made, you receive a long tone through the handset or speaker.
 - If you are already on a conference call or another group call, you do not receive notification of a group call.

To end a group call:



(Goodbye)

Press the **Goodbye** key.

Note: When the person who made the group call disconnects, the call terminates for all members of the group. However, the members of the group call can disconnect from the call and not affect other members on the call.

Working without interruption

This section describes the Activating Make Set Busy feature, which provides uninterrupted work time.

Note: Uninterrupted work time can also be obtained by forwarding your calls to another telephone number (see Using Call Forward on page 65) or directing your calls to your voice mailbox.

Activating Make Set Busy

Use the Make Set Busy feature to make your telephone appear busy to all callers.

To activate Make Set Busy:



Lift the handset and enter the **Make Set Busy Activate** FFC.

To deactivate Make Set Busy:



Lift the handset and enter the **Make Set Busy Deactivate** FFC.

Additional call features

Contact your system administrator to determine if the following call features are available on your telephone.

- “Using Call Page Connect to make an announcement” on page 76
- “Charging a call or charging a forced call” on page 77
- “Using Enhanced Override” on page 80
- “Using Forced Camp-on” on page 81
- “Overriding a busy signal” on page 83
- “Using Privacy Release” on page 83
- “Using Radio Page” on page 84

Using Call Page Connect to make an announcement

Use the Call Page Connect feature to make an announcement over a paging system.

Note: A **Page** key on an attendant console overrides and disconnects the telephones. The telephones must reaccess the page trunk.

To connect to Call Page:



1. Lift the handset.



2. Dial the **Page Trunk Access Code** to complete the connection to the page system.

3. Make your announcement.



(Goodbye)

4. Press the **Goodbye** key.

Charging a call or charging a forced call

Use the Call Charge feature to charge a call to a specific account. The Forced Charge feature charges long-distance calls from a telephone restricted to local calls.

To charge a local or long-distance call to an account before you dial:



Charge



1. Lift the handset.
2. Choose one of the following:
 - Press the **Charge** context-sensitive soft key.
 - Dial the **Call Detail Recording** FFC.



3. Dial the charge account number.



4. When the dial tone sounds, dial the number.

To charge a call in progress:



1. Choose one of the following:
 - Press the **Transfer** context-sensitive soft key.
 - Press the **Conference** context-sensitive soft key.



or



2. Choose one of the following:
 - Press the **Charge** context-sensitive soft key.
 - Dial the **Call Detail Recording** FFC.
3. Dial the charge account number.
4. Press the line (DN) key to return to the call.

To charge a call to an account when you transfer a call:



1. Press the **Transfer** context-sensitive soft key. The call is on hold.

Charge



or



Trans



2. Choose one of the following:
 - Press the **Charge** context-sensitive soft key.
 - Dial the **Call Detail Recording** FFC.

3. Dial the charge account number.

4. After the dial tone, dial the number to which you are transferring the call.

5. Press the **Transfer** context-sensitive soft key when you hear the telephone ring.

Note: You can talk privately to the person at the transfer number before you press the **Transfer** context-sensitive soft key.

To charge a call to an account when you add someone to a conference call:

Conf



1. Press the **Conference** context-sensitive soft key. The call is placed on hold.

Charge



or



Conf



2. Choose one of the following:
 - Press the **Charge** context-sensitive soft key.
 - Dial the **Call Detail Recording** FFC.

3. Dial the charge account number.

4. Dial the number of the person you want to add to the conference.

5. Press the **Conference** context-sensitive soft key.

Using Enhanced Override

Use the Enhanced Override feature to override an active call after you attempt a Forced Camp-on. Use Enhanced Override to make a call or a consultation call, such as placing a call on hold and calling another party.

To use Enhanced Override:



You receive a busy signal after dialing a telephone number.



1. Enter the **Override** FFC to initiate a Forced Camp-on.
 - If either person on the call disconnects at this time, you receive an overflow (fast busy or engaged) signal.

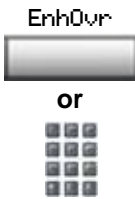

2. Enter the **Override** FFC again.
 - The other two people on the call receive an override tone and a conference call is established between the three of you. If anyone disconnects, the other two people remain connected.



3. To terminate the call, press the **Goodbye** key.

Using Forced Camp-on

Use the Forced Camp-on feature to automatically ring another telephone (internal or external) immediately after that telephone disconnects from its current call.

To use Forced Camp-on:



You receive a busy signal after dialing a telephone number.



1. Enter the **Override** FFC, to initiate a Forced Camp-on.

Note: The person you called receives a tone, and you receive a ring signal or a busy signal, depending on the options chosen. You are now camped-on to the number you dialed.



2. Return the handset to the cradle.
 - When the person you called finishes their call, your telephone automatically dials the number and both telephones ring.

Answering a call camped-on to your extension:



When your telephone rings, lift the handset.

Note: You can program your telephone for either Camp-on or Call Waiting, but not both.

Overriding a busy signal

Use the Override feature to override a busy signal and interrupt another call.

To override a busy signal:



You receive a busy signal after dialing a telephone number.



1. Enter the **Override** FFC.
 - The people in the targeted call receive a tone for approximately 1 second. After Override joins you to their call, a short tone repeats every 16 seconds.



(Goodbye)

2. To terminate the call, press the **Goodbye** key.

Using Privacy Release

Use the Privacy Release feature to enable one or more people who share your DN to join a call.

To use Privacy Release in an established state:



Press the **Privacy Release** context-sensitive soft key during a call.

- People can join the call by pressing the shared number (DN) key on their telephone (Multiple Appearance DN feature).

Using Radio Page

Use the Radio Page feature to page a person and stay on the line until they answer. The paged person answers the call after entering a special Page Meet-me code from any telephone.

To use Automatic Preselection (Meet-me page):



1. Lift the handset.



2. Dial the **Radio Paging Access** FFC.

- The paging tone sounds (two beeps followed by a dial tone).



3. Dial the number of the party you want to page.

- After dialing, the ringback tone sounds.

Note: The paged person can use any telephone to enter a **Radio Paging Answer** FFC, plus their own DN number.



4. If your call goes unanswered for a preset time period and a 15-second high-pitched tone sounds followed by silence, press the **Goodbye** key or replace the handset.

To use Automatic Post-selection:

The called party is either busy on the telephone or away from their desk. To page the called party, you do not need to redial the number of the called party.



1. Press the **Radio Page** context-sensitive soft key.
 - A special dial tone sounds.



2. Dial the **Radio Paging Access** FFC.
 - The ringback tone sounds.

Note: The paged person can use any telephone to enter a **Radio Paging Answer** FFC, plus their own DN number.

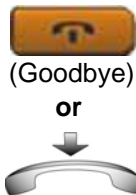

3. If your call goes unanswered for a preset time period and a 15-second high-pitched tone sounds, followed by silence, press the **Goodbye** key or replace the handset.

To answer a Radio Page:

If you carry a Radio Pager, a page indicates that someone dialed your DN. If the Radio Page system is configured to function in Meet-me mode, you can answer the page call from any telephone.



1. Lift the handset.



2. Dial the **Radio Paging Answer** FFC.
— The paging tone sounds.



3. Dial your own DN to connect to the paging caller. If the caller has disconnected, a steady high-pitched (number unavailable) tone sounds.

Additional phone features

The following features are described in this section:

- [“Secure Communication” on page 87](#)
- [“Using Virtual Office” on page 87](#)
- [“Using Media Gateway 1000B” on page 98](#)

Secure Communication

Your Avaya 1110 IP Deskphone supports secure communication with other Avaya IP Deskphones by encrypting your calls using a Pre-Shared Key (PSK). If the PSK feature is enabled on both Avaya IP Deskphones, a PSK security icon (:) is displayed on the LCD screen when a secure communication link is established. Consult your system administrator to find out if this feature is enabled on your IP Deskphone.

Using Virtual Office

The Virtual Office feature provides a service you can use while you are away from your desk to transfer calls, and all your office telephone features, to a remote telephone. Virtual Office makes this possible by allowing you to use another IP Deskphone (the Remote phone) to log in to your own home or office IP Deskphone (the Office phone). After you log in, you can access the DNs, key layout, and voicemail features that are configured on your own home or office IP Deskphone.

To use Virtual Office, you need your DN and preconfigured Station Control Password (SCPW). You must activate Virtual Office on your Office phone before you can connect to it from a Remote phone. See [“Logging in to Virtual Office” on page 89](#).

Note: Consult your system administrator to verify if the Virtual Office feature is available for your use.

You can use an IP Deskphone as a Remote phone to connect to your Avaya 1110 IP Deskphone even if it is a different IP Deskphone model. **Table 7** shows the IP Deskphones on which you can use Virtual Office to connect to your Avaya 1110 IP Deskphone.

Table 7: Virtual Office connection availability

IP Deskphone model	Possible to log in to the 1110?
Avaya 1110 IP Deskphone	Yes
Avaya 1120E IP Deskphone	Yes, with restrictions
Avaya 1140E IP Deskphone	Yes, with restrictions
Avaya 1150E IP Deskphone	No
Avaya 1165E IP Deskphone	Yes, with extra key restrictions
Avaya 1210 IP Deskphone	Yes, with extra key restrictions
Avaya 1220 IP Deskphone	Yes, with extra key restrictions
Avaya 1230 IP Deskphone	Yes, with extra key restrictions
IP Phone 2001	Yes
IP Phone 2002	Yes, with restrictions
IP Phone 2004	Yes, with restrictions
Avaya 2007 IP Deskphone	Yes, with restrictions
Avaya 2033 IP Conference Phone	Yes, with restrictions
Avaya 2050 IP Softphone	Yes, with restrictions

Note 1: When logged into an Avaya 1110 IP Deskphone from another IP Deskphone using Virtual Office, your IP Deskphone is limited to the features available on the Avaya 1110 IP Deskphone.

Note 2: A Virtual Office login to an Avaya 1110 IP Deskphone from another IP Deskphone is blocked in certain situations. Consult your system administrator.

Logging in to Virtual Office

If the IP Deskphone is configured for Virtual Office, the Virtual soft key is displayed, as shown in Figures 7.

Figure 7: Virtual Soft key — small phone

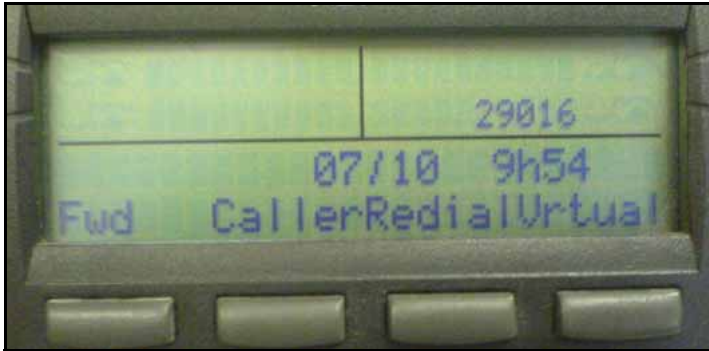

To activate Virtual Office from this IP Deskphone on your Office IP

1. Press the **Virtual Soft** key.



2. At the prompt, enter your user ID.



3. Press the **Enter** key.



4. At the prompt, enter the home **Station Control Password (SCPW)**.

A successful login transfers all the features, time, date, and tones to your Remote telephone from your Office telephone.

Note 1: If the user ID is not found locally, the message “Locating Remote Server” is displayed.

Note 2: After three failed login attempts, wait 1 hour before attempting to log in again, or contact your system administrator to reset your password.

Note 3: Your Virtual Office session expires after a fixed period of time, (determined by your system administrator).

Deskphone:

Using Virtual Office on your Remote telephone

Because the display characteristics, including size, vary from one IP Deskphone model to the next, your Office Avaya 1110 IP Deskphone

display is different on each Remote phone. **Figures 8 to 10** show LCD displays of various IP Deskphones when they are logged on to an Avaya 1110 IP Deskphone using Virtual Office.

Figure 8 shows an Avaya 1120E IP Deskphone logged in as a Remote phone to an Avaya 1110 IP Deskphone Office phone.

Figure 8: Avaya 1120E IP Deskphone logged in to an Avaya 1110 IP Deskphone

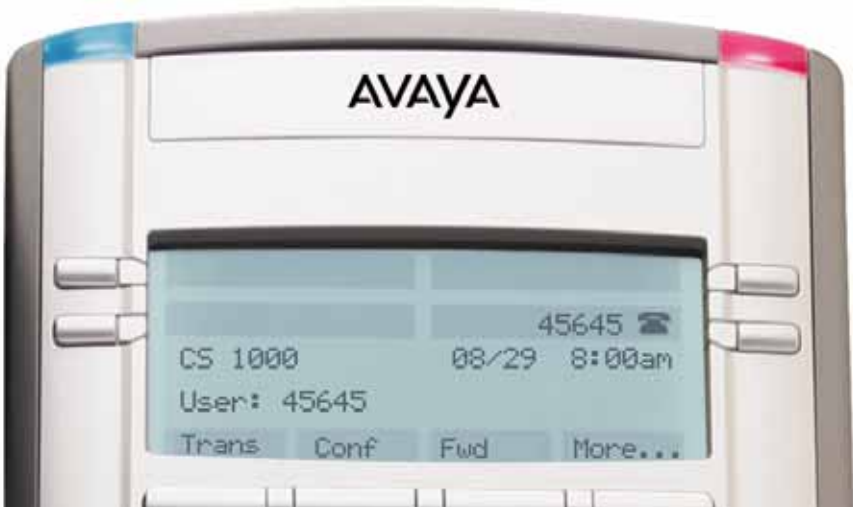

Figure 9 shows an Avaya 1140E IP Deskphone logged in as a Remote phone to an Avaya 1110 IP Deskphone Office phone.

Figure 9: Logged in to an Avaya 1110 IP Deskphone using an Avaya 1140E IP Deskphone



Figure 10 shows an Avaya 2050 IP Softphone logged in as a Remote phone to an Avaya 1110 IP Deskphone Office phone.

Figure 10: Logged in to an Avaya 1110 IP Deskphone using an Avaya 2050 IP Softphone

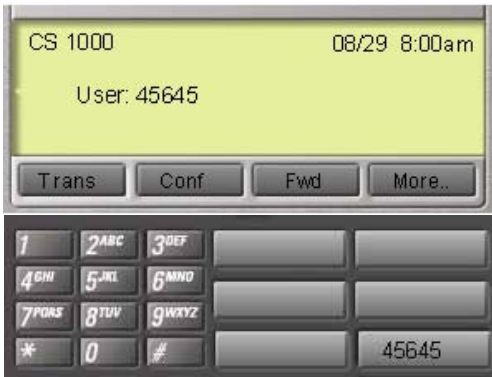

Note 1: On the displays of the IP Phone 2002, IP Phone 2004, Avaya 1120E IP Deskphone, Avaya 1140E IP Deskphone, and Avaya 2050 IP Softphone, the feature keys remain empty (except for the appearance of your DN), because your Avaya 1110 IP Deskphone does not support feature keys.

Note 2: A User information line appears on all displays listing the number of your office telephone.

Using Virtual Office on your Office telephone

Figure 11 shows the Avaya 1110 IP Deskphone display when the phone is logged out due to remote access.

Figure 11: Office phone displays the message *Logged Out*



When activated for Virtual Office by a Remote telephone, your Office telephone is *logged out* and no longer operational. If this is the case when you return to your office, you can disconnect the remote login and regain control of your Office phone. If you do not disconnect the remote login, your Virtual Office session expires after a fixed period of time, determined by your system administrator.

To regain operation of a telephone being used for Virtual Office:

Choose one of the following:



- To completely disconnect your Office telephone from the Remote telephone:
 - a. Press the **Home** context-sensitive soft key.
 - b. Enter your User ID and password (this logs the Office telephone back on to your office network).
- Press the **Virtual** context-sensitive soft key to log in to another IP Deskphone, and your telephone becomes a Remote telephone.

Logging out of Virtual Office

To log out of Virtual Office, press the **Virtual soft** key.

Automatic log out from Virtual Office

Your remote Virtual Office IP Deskphone may be configured to automatically log out of Virtual Office after a predetermined period of inactivity. When automatic logout is about to occur, the following message is displayed on the IP Deskphone: "**Logout phone now?**"

Press **Yes** to allow the IP Deskphone to log out of Virtual Office or press **No** to remain logged in to Virtual Office and reset the IDLE timer. If no key is pressed, the IP Deskphone logs out of Virtual Office.

Emergency calls on your Remote IP Deskphone

If you make an emergency call while logged in to Virtual Office on a Remote IP Deskphone, the call is placed to the local emergency service, not to your home office emergency service.

Note: Some IP Deskphones are configured as Virtual Office-only telephones and have no assigned DN. However, these IP

Deskphones can still be used to make emergency calls. “Emergency Calls only” is displayed on the IP Deskphone display when not logged in to Virtual Office. When the phone goes off-hook, dial tone is available for emergency calls only. All other calls are restricted.

Troubleshooting Virtual Office

Virtual Office can display error messages on-screen. Table 8 lists error messages and describes actions to correct the causes.

Table 8: Troubleshooting Virtual Office (Part 1 of 3)

Displayed Message	Probable Cause	Actions
Busy, try again	Remote IP Deskphone is active (not idle).	Wait for remote IP Deskphone to become idle and try again.
	ACD is logged in.	Log out ACD IP Deskphone before Virtual Office from another IP Deskphone.
	Make Set Busy is inactive on ACD IP Deskphone.	Configure Make Set Busy active on ACD IP Deskphone.
Invalid ID (1)	Incorrect User ID entered.	Enter correct User ID.
	User ID is not in Gatekeeper database.	Notify system administrator.
Invalid ID (2)	Incorrect User ID entered.	Enter correct User ID.

Table 8: Troubleshooting Virtual Office (Part 2 of 3)

Displayed Message	Probable Cause	Actions
Invalid ID (3)	Incorrect User ID entered.	Enter correct User ID.
	User ID in Gatekeeper database points to originating Call Server.	Notify system administrator.
Locked from Login	Three failed attempts to enter the correct Station Control Password.	Wait one hour for the lock to clear automatically, or notify system administrator to clear lock.
Permission Denied (1)	Remote telephone has no Station Control Password.	Notify system administrator.
Permission Denied (3)	Incorrect User ID entered.	Enter correct User ID.
	Remote telephone has no Station Control Password.	Notify system administrator.
Permission Denied (4)	Incorrect User ID entered.	Enter correct User ID.
	Attempt to log in to a remote IP Phone 2004 or Avaya 2050 IP Softphone from an Avaya 1110 IP Deskphone (some restrictions apply).	Go to an IP Phone 2004 or Avaya 2050 IP Softphone and try again, or consult your local system administrator.

Table 8: Troubleshooting Virtual Office (Part 3 of 3)

Displayed Message	Probable Cause	Actions
Permission Denied (6)	Incorrect User ID entered.	Enter correct User ID.
	Incorrect Station Control Password entered.	Select Retry, and try again with the correct Station Control Password.
Server Unreachable (1)	Network problem.	Notify system administrator if the problem persists.
Server Unreachable (2)	Network problem.	Notify system administrator if the problem persists.
VOUD configured on TN	Remote IP Deskphone does not have VOUA Class of Service.	Notify system administrator.

Using Media Gateway 1000B

The Media Gateway 1000B (MG 1000B) provides a means of extending CS 1000 Release 4.5 features to one or more remotely located branch offices using the Branch Office feature. A branch office is a remote location in the network where IP Deskphones, PSTN access, and TDM telephones are located. Contact your system administrator to see if these functions are available for your use.

The Media Gateway 1000B (MG 1000B) telephone can operate in Normal or Local Mode.

Normal Mode

The telephone registers with the Main Office and receives telephone services from the Main Office. At any time during Normal Mode, you can check Local Mode functionality (make and receive calls) by enabling Local Mode and returning to Normal Mode. After testing, you can return to

Normal Mode (see [“Using Resume Normal Mode” on page 100](#)) or by waiting for 10 minutes.

Local Mode

If the WAN connection fails, the IP Deskphone loses communication with the Main Office Telephone Preference Service (TPS). It then registers with the MG 1000B and receives telephone services from the MG 1000B. When in Local Mode, the telephone displays the message *LOCAL MODE*.

This section provides more information on the following topics:

- Using Test Local Mode
- Using Resume Normal Mode
- Troubleshooting MG 1000B

Using Test Local Mode

Use Test Local Mode to check Local Mode functionality (make and receive telephone calls). Test Local Mode is useful when provisioning has changed for an IP Deskphone on an MG 1000B Controller.



(Services)

1. Press the **Services** key.



2. Press the **Up/Down** navigation keys to scroll up or down, and then highlight **Test Local Mode**.



3. Press the **Enter** key (the telephone resets and registers back to the Main Office).

Using Resume Normal Mode

Use the Resume Normal Mode command to return to Normal Mode after testing survival functionality.

Note: If you do not use the Resume Normal Mode command after testing, the telephone automatically returns to Normal Mode in 10 minutes.



(Services)

1. Press the **Services** key.



2. Press the **Up/Down** navigation key to scroll and highlight **Resume Normal Mode**.



3. Press the **Enter** key (the telephone registers back to the main office).

Troubleshooting MG 1000B

The MG 1000B can display error messages on-screen. Table 9 lists error messages and describes actions to correct the causes.

Table 9: Troubleshooting MG 1000B (Part 1 of 2)

Display Message	Probable Cause	Actions
Local Mode	Test Local Mode. Network problem.	Press the Services key, and then select Resume Normal Mode. Contact system administrator if problem persists.

Table 9: Troubleshooting MG 1000B (Part 2 of 2)

Display Message	Probable Cause	Actions
Local Mode Invalid ID (1)	Gatekeeper unable to find end point from Branch User ID.	Notify system administrator.
Local Mode Invalid ID (2)	Branch User ID not found in any equipped TN.	Notify system administrator.

Using Hospitality features

Hospitality features are intended for hotel operations. The following features are discussed in this section:

- “Configuring Automatic Wake-Up” on page 102

Configuring Automatic Wake-Up

Use the Automatic Wake-Up feature to receive a timed reminder call. From your telephone, you can program the system to automatically place a call to you at a predetermined time. When you answer the call, recorded music plays for up to 30 seconds, followed by a prerecorded announcement or the attendant.

To enter the time for an Automatic Wake-Up call:



1. Lift the handset.



2. Dial the **Automatic Wake-Up Request FFC**.



3. Dial the **Automatic Wake-Up** time in a 24-hour time format (hhmm).

— A tone sounds to confirm your entered time.

Note: In a 24-hour time format, 7:30 a.m. is entered as 0730; 9:45 p.m. is entered as 2145.



(Goodbye)

4. Press the **Goodbye** key.

To cancel an Automatic Wake-Up call:



1. Lift the handset.



2. Dial the **Automatic Wake-Up Quit** FFC.



(Goodbye)

3. Press the **Goodbye** key.

To verify the time for the Automatic Wake-Up call:



1. Lift the handset.



2. Dial the **Automatic Wake-Up Verify** FFC.



3. Dial the **Automatic Wake-Up** time in a 24-hour time format (hhmm). If your query matches the preset time, a confirmation tone sounds.

Note: In a 24-hour time format, 7:30 a.m. is entered as 0730; 9:45 p.m. is 2145.



(Goodbye)

4. Press the **Goodbye** key.

Station Control Password

Some features on your Avaya 1110 IP Deskphone are supported by a Station Control Password (SCPW). The SCPW supports the following telephone features:

- Electronic Lock
 - to prevent others from making calls from your telephone
- Remote Call Forward
- Virtual Office login
- Branch Office login

Your system administrator defines your initial SCPW. Contact your system administrator for detailed information.

Changing your Station Control Password:



(Services)

1. Press the **Services** key.



2. Press the **Up/Down** navigation keys to scroll up or down, and then highlight **Password Admin**.



3. Press the **Enter** key.



4. Use the dialpad to enter your password at the prompt.



5. Press the **Up/Down** navigation keys to scroll up or down, and then highlight **New Password**.



6. Press the **Enter** key.



7. Use the dialpad to enter the new password.



8. Press the **Enter** key to accept the new password.

Note: If you are locked out of your Avaya 1110 IP Deskphone, or if you forget your SCPW, contact your system administrator.

Accessing External Server Applications

Use External Server Applications to access a variety of applications directly from your Avaya 1110 IP Deskphone.

To find out what features and services are available, contact your system administrator. Depending on what is available on your system, your phone can provide information; for example, local news and weather, stock market information, or traffic reports.

For more information about the External Server Applications, consult the *Avaya IP Deskphone External Server Applications User Guide*.

Flexible Feature Codes (FFC)

Use Table 10 to keep track of the FFCs that the system administrator assigns to your Avaya 1110 IP Deskphone:

Table 10: Flexible Feature Codes (Part 1 of 2)

FFC	Feature	FFC	Feature
	Automatic Wake-Up Activate		Make Set Busy Activate
	Automatic Wake-Up Deactivate		Make Set Busy Deactivate
	Automatic Wake-Up Verify		Malicious Call Trace
	Call Detail Recording Charge Account		Override
	Call Forward All Calls Activate		Pickup Ringing Number
	Call Forward All Calls Deactivate		Pickup Directory Number
	Call Park		Pickup Group
	Electronic Lock Activate		Radio Paging Access
	Electronic Lock Deactivate		Radio Paging Answer
	Group Call		Remote Call Forward Activate
	Internal Call Forward Activate		Remote Call Forward Deactivate
	Internal Call Forward Deactivate		RingAgain Activate

Table 10: Flexible Feature Codes (Part 2 of 2)

FFC	Feature	FFC	Feature
	RingAgain Deactivate		Virtual Office Terminal Log Off
	Station Control Password Change		Virtual Office Terminal Log On

Quick Reference



Feature operation

Call Forward

Activate	Fwd		▶ Fwd
Deactivate	▶ Fwd		
Reinstate	Fwd	▶ Fwd	

Call PickUp



Pickup

Conference



Hold

Place a call on hold 

Return to a held call 

Last Number Redial



Message

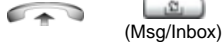

Ring Again

Activate RngAgn

When notified  ▶ RngAgn

Deactivate ▶ RngAgn

Transfer



Adjust volume

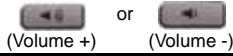

Legend

Icon	Action
()	Indicates the key cap text label. For example, (Message).
	Lift the handset.
	Replace the handset.
(Goodbye)	Press the goodbye key.
	Dial a number.
	Press the line key.
Fwd	An icon flashes when a feature is being programmed. An icon lights steadily when a feature is active.
	Press the Services key once for server-based features, or press the Services key twice for local phone features.
	Press the Message/Inbox key.
	Press the Up/Down Navigation keys
	Press the Enter key
	Press the Expand key

Services and Telephone Options menus

Services menu



Note: The **Services** menu contains the **Telephone Options**, **Password Admin**, **Virtual Office**, and **MG 1000B** menus. These options are not available on all Avaya 1110 IP Deskphones. Consult your system administrator.

Telephone Options menu

The following are the most commonly used options:

Volume adjustment

Choose one of:

- . Ringer
- . Handset Listen
- . Listen-only speaker
- . Buzzer



Contrast adjustment

**Language**

Note: This language setting controls the language used by features on your phone only. To set the language used elsewhere on your phone, press **Services** twice, select 1. Preferences, and select 2. Language.

Date/Time format**Local DialPad Tone****Ring type**

Play

**Call Timer**

On Off



Regulatory and safety information

This equipment has been tested and found to comply with the limits for a Class B digital device, pursuant to part 15 of the FCC Rules. These limits are designed to provide reasonable protection against harmful interference in a residential installation. This equipment generates, uses and can radiate radio frequency energy and, if not installed and used in accordance with the instructions, may cause harmful interference to radio communications. However, there is no guarantee that interference will not occur in a particular installation. If this equipment does cause harmful interference to radio or television reception, which can be determined by turning the equipment off and on, the user is encouraged to try to correct the interference by one or more of the following measures:

- Reorient or relocate the receiving antenna.
- Increase the separation between the equipment and receiver.
- Connect the equipment into an outlet on a circuit different from that to which the receiver is connected.
- Consult the dealer or an experienced radio/ TV technician for help.

Note: The user should not make changes or modifications not expressly approved by Avaya. Any such changes could void the user's authority to operate the equipment.

This Class B digital apparatus complies with Canadian ICES-003. Cet appareil numérique de la classe B est conforme à la norme NMB-003 du Canada.

Warnings:

- This is a Class B product. In a domestic environment this product can cause radio interference in which case the user must take adequate measures.
- Operation is subject to the following two conditions: (1) this device may not cause interference, and (2) this device must accept any interference, including interference that may cause undesired operation of the device.

この装置は、情報処理装置等電波障害自主規制協議会（VCCI）の基準に基づくクラスB情報技術装置です。この装置は、家庭環境で使用することを目的としていますが、この装置がラジオやテレビジョン受信機に近接して使用されると、受信障害を引き起こすことがあります。

取扱説明書に従って正しい取り扱いをして下さい。

Table 11 lists EMC compliance for various jurisdictions.

Table 11: EMC Compliance

Jurisdiction	Standard	Description
United States	FCC CFR 47 Part 15	Class B Emissions: FCC Rules for Radio Frequency Devices
Canada	ICES-003	Class B Emissions: Interference-Causing Equipment Standard: Digital Apparatus
Australia/New Zealand	AS/NZS 3548 CISPR 22	Class B Emissions: Information technology equipment - Radio disturbance
European Community	EN 55022	Class B Emissions: Information technology equipment - Radio disturbance
	EN 55024	Information technology equipment - Immunity characteristics Limits and methods of measurement
	EN 61000-3-2	Limits for harmonic current emissions (equipment input current \leq 16 A per phase)
	EN 61000-3-3	Limitation of voltage fluctuations and flicker in low-voltage supply systems for equipment with rated current \leq 16 A
Japan	VCCI	Regulations for voluntary control measures.

Table 12: Safety

Jurisdiction	Standard	Description
United States	UL 60950-1	Safety of Information Technology Equipment
Canada	CSA 60950-1-03	Safety of Information Technology Equipment
European Community	EN 60950-1	ITE equipment - Safety - Part 1: General requirements
Australia/New Zealand	AS/NZS 60950.1:2003	Safety of Information Technology Equipment

Other Safety Approvals: IEC 60950-1: ITE equipment - Safety - Part 1: General requirements

Other

US/Canada: Hearing Aid Compatibility (HAC) as per FCC Part 68

This equipment complies with the CE Marking requirements. 

Australia: AS/ACIF S004: Voice Frequency Performance Requirements for Customer Equipment

EU Countries: This device complies with the essential requirements and other relevant provisions of Directive 1999/5/EC. A copy of the Declaration may be obtained from <http://www.avaya.com> or Avaya Inc., 211 Mt. Airy Road, Basking Ridge, NJ 07920 USA..

DenAn regulatory notice for Japan

Warning

Please be careful of the following while installing the equipment:

- Please only use the Connecting cables, power cord, AC adaptors shipped with the equipment or specified by Avaya to be used with the equipment. If you use any other equipment, it may cause "failures, malfunctioning or fire".
- Power cords shipped with this equipment must not be used with any other equipment. In case the above guidelines are not followed, it may lead to death or severe injury

警告

本製品を安全にご使用頂くため、以下のことにご注意ください。

- 接続ケーブル、電源コード、ACアダプタなどの部品は、必ず製品に同梱されており添付品または指定品をご使用ください。添付品・指定品以外の部品をご使用になると故障や動作不良、火災の原因となることがあります。
- 同梱されております付属の電源コードを他の機器には使用しないでください。上記注意事項を守らないと、死亡や大怪我など人身事故の原因となることがあります。

Third party terms

Third Party Terms for UNISlim sw releases 4.1 thru 5.0 (Jan 2010 - Nov 2010)

Certain portions of the product ("Open Source Components") are licensed under open source license agreements that require Avaya to make the source code for such Open Source Components available in source code format to its licensees, or that require Avaya to disclose the license terms for such Open Source Components. For a period of three years from your date of purchase of a product containing any of the software listed below from Avaya Inc., any Avaya affiliate or an authorized Avaya reseller, we will provide upon request a complete machine readable copy of the source code for such Open Source Component on a medium customarily used for software interchange for a charge no more than our cost of physically performing source distribution. To get access to the source code, you may contact Avaya at (408) 577-7666.

The Open Source Components are provided "AS IS". ANY EXPRESS OR IMPLIED WARRANTIES, INCLUDING, BUT NOT LIMITED TO, THE IMPLIED WARRANTIES OF MERCHANTABILITY AND FITNESS FOR A PARTICULAR PURPOSE ARE DISCLAIMED. IN NO EVENT SHALL THE COPYRIGHT HOLDERS OR THE CONTRIBUTORS OF THE OPEN SOURCE COMPONENTS BE LIABLE FOR ANY DIRECT, INDIRECT, INCIDENTAL, SPECIAL, EXEMPLARY, OR CONSEQUENTIAL DAMAGES (INCLUDING, BUT NOT LIMITED TO, PROCUREMENT OF SUBSTITUTE GOODS OR SERVICES; LOSS OF USE, DATA, OR PROFITS; OR BUSINESS INTERRUPTION) HOWEVER CAUSED AND ON ANY THEORY OF LIABILITY, WHETHER IN CONTRACT, STRICT LIABILITY, OR TORT (INCLUDING NEGLIGENCE OR OTHERWISE) ARISING IN ANY WAY OUT OF THE USE OF THE PRODUCT, EVEN IF ADVISED OF THE POSSIBILITY OF SUCH DAMAGE.

The following component is licensed under Public Domain:

DateTime

- * PUBLIC DOMAIN NOTICE
- * National Center for Biotechnology Information

*

* This software/database is a "United States Government Work" under the terms of the United States Copyright Act. It was written as part of the author's official duties as a United States Government employee and thus cannot be copyrighted. This software/database is freely available to the public for use. The National Library of Medicine and the U.S. Government have not placed any restriction on its use or reproduction.

*

* Although all reasonable efforts have been taken to ensure the accuracy and reliability of the software and data, the NLM and the U.S. Government do not and cannot warrant the performance or results that may be obtained by using this software or data. The NLM and the U.S. Government disclaim all warranties, express or implied, including warranties of performance, merchantability or fitness for any particular purpose.

*

* Please cite the author in any work or product based on this material.

*

* =====

*

* Authors: Anton Butanayev, Denis Vakатов, Vladimir Ivanov

END OF TERMS AND CONDITIONS

GNU

The following component is licensed under the GNU General Public V2 license:

libstdc++ Copyright (C) 1989, 1997, 1998, 1999 Free Software Foundation, Inc.

GNU General Public V2 License

GNU GENERAL PUBLIC LICENSE Version 2, June 1991 Copyright (C) 1989, 1991 Free Software Foundation, Inc. 59 Temple Place - Suite 330, Boston, MA 02111-1307, USA Everyone is permitted to copy and distribute verbatim copies of this license document, but changing it is not allowed. Preamble The licenses for most software are designed to take

away your freedom to share and change it. By contrast, the GNU General Public License is intended to guarantee your freedom to share and change free software--to make sure the software is free for all its users. This General Public License applies to most of the Free Software Foundation's software and to any other program whose authors commit to using it. (Some other Free Software Foundation software is covered by the GNU Library General Public License instead.) You can apply it to your programs, too. When we speak of free software, we are referring to freedom, not price. Our General Public Licenses are designed to make sure that you have the freedom to distribute copies of free software (and charge for this service if you wish), that you receive source code or can get it if you want it, that you can change the software or use pieces of it in new free programs; and that you know you can do these things. To protect your rights, we need to make restrictions that forbid anyone to deny you these rights or to ask you to surrender the rights. These restrictions translate to certain responsibilities for you if you distribute copies of the software, or if you modify it. For example, if you distribute copies of such a program, whether gratis or for a fee, you must give the recipients all the rights that you have. You must make sure that they, too, receive or can get the source code. And you must show them these terms so they know their rights. We protect your rights with two steps: (1) copyright the software, and (2) offer you this license which gives you legal permission to copy, distribute and/or modify the software. Also, for each author's protection and ours, we want to make certain that everyone understands that there is no warranty for this free software. If the software is modified by someone else and passed on, we want its recipients to know that what they have is not the original, so that any problems introduced by others will not reflect on the original authors' reputations. Finally, any free program is threatened constantly by software patents. We wish to avoid the danger that redistributors of a free program will individually obtain patent licenses, in effect making the program proprietary. To prevent this, we have made it clear that any patent must be licensed for everyone's free use or not licensed at all. The precise terms and conditions for copying, distribution and modification follow.

TERMS AND CONDITIONS FOR COPYING, DISTRIBUTION AND MODIFICATION

0. This License applies to any program or other work which contains a notice placed by the copyright holder saying it may be distributed under the terms of this General Public License. The "Program", below, refers to any such program or work, and a "work based on the Program" means either the Program or any derivative work under copyright law: that is to say, a work containing the Program or a portion of it, either verbatim or with modifications and/or translated into

another language. (Hereinafter, translation is included without limitation in the term "modification".) Each licensee is addressed as "you". Activities other than copying, distribution and modification are not covered by this License; they are outside its scope. The act of running the Program is not restricted, and the output from the Program is covered only if its contents constitute a work based on the Program (independent of having been made by running the Program). Whether that is true depends on what the Program does.

1. You may copy and distribute verbatim copies of the Program's source code as you receive it, in any medium, provided that you conspicuously and appropriately publish on each copy an appropriate copyright notice and disclaimer of warranty; keep intact all the notices that refer to this License and to the absence of any warranty; and give any other recipients of the Program a copy of this License along with the Program. You may charge a fee for the physical act of transferring a copy, and you may at your option offer warranty protection in exchange for a fee.
2. You may modify your copy or copies of the Program or any portion of it, thus forming a work based on the Program, and copy and distribute such modifications or work under the terms of Section 1 above, provided that you also meet all of these conditions:
 - * a) You must cause the modified files to carry prominent notices stating that you changed the files and the date of any change.
 - * b) You must cause any work that you distribute or publish, that in whole or in part contains or is derived from the Program or any part thereof, to be licensed as a whole at no charge to all third parties under the terms of this License.
 - * c) If the modified program normally reads commands interactively when run, you must cause it, when started running for such interactive use in the most ordinary way, to print or display an announcement including an appropriate copyright notice and a notice that there is no warranty (or else, saying that you provide a warranty) and that users may redistribute the program under these conditions, and telling the user how to view a copy of this License. (Exception: if the Program itself is interactive but does not normally print such an announcement, your work based on the Program is not required to print an announcement.)These requirements apply to the modified work as a whole. If identifiable sections of that work are not derived from the Program, and can be reasonably considered independent and separate works in themselves, then this License, and its terms, do not apply to those sections when you distribute them as separate works. But when you distribute the same sections as part of a whole which is a work based on the Program, the distribution of the whole must be on the terms of this License, whose permissions for other licensees extend to the entire whole, and thus to each and every part regardless of who wrote it. Thus, it is not the intent of this section to claim rights or contest your rights

to work written entirely by you; rather, the intent is to exercise the right to control the distribution of derivative or collective works based on the Program. In addition, mere aggregation of another work not based on the Program with the Program (or with a work based on the Program) on a volume of a storage or distribution medium does not bring the other work under the scope of this License. 3. You may copy and distribute the Program (or a work based on it, under Section 2) in object code or executable form under the terms of Sections 1 and 2 above provided that you also do one of the following: * a) Accompany it with the complete corresponding machine-readable source code, which must be distributed under the terms of Sections 1 and 2 above on a medium customarily used for software interchange; or, * b) Accompany it with a written offer, valid for at least three years, to give any third party, for a charge no more than your cost of physically performing source distribution, a complete machine-readable copy of the corresponding source code, to be distributed under the terms of Sections 1 and 2 above on a medium customarily used for software interchange; or, * c) Accompany it with the information you received as to the offer to distribute corresponding source code. (This alternative is allowed only for noncommercial distribution and only if you received the program in object code or executable form with such an offer, in accord with Subsection b above.) The source code for a work means the preferred form of the work for making modifications to it. For an executable work, complete source code means all the source code for all modules it contains, plus any associated interface definition files, plus the scripts used to control compilation and installation of the executable. However, as a special exception, the source code distributed need not include anything that is normally distributed (in either source or binary form) with the major components (compiler, kernel, and so on) of the operating system on which the executable runs, unless that component itself accompanies the executable. If distribution of executable or object code is made by offering access to copy from a designated place, then offering equivalent access to copy the source code from the same place counts as distribution of the source code, even though third parties are not compelled to copy the source along with the object code. 4. You may not copy, modify, sublicense, or distribute the Program except as expressly provided under this License. Any attempt otherwise to copy, modify, sublicense or distribute the Program is void, and will automatically terminate your rights under this License. However, parties who have received copies, or rights, from you under this License will not have their licenses terminated so long as such parties remain in full compliance. 5. You are not required to accept this License, since you have not signed it. However, nothing else grants you permission to modify

or distribute the Program or its derivative works. These actions are prohibited by law if you do not accept this License. Therefore, by modifying or distributing the Program (or any work based on the Program), you indicate your acceptance of this License to do so, and all its terms and conditions for copying, distributing or modifying the Program or works based on it. 6. Each time you redistribute the Program (or any work based on the Program), the recipient automatically receives a license from the original licensor to copy, distribute or modify the Program subject to these terms and conditions. You may not impose any further restrictions on the recipients' exercise of the rights granted herein. You are not responsible for enforcing compliance by third parties to this License. 7. If, as a consequence of a court judgment or allegation of patent infringement or for any other reason (not limited to patent issues), conditions are imposed on you (whether by court order, agreement or otherwise) that contradict the conditions of this License, they do not excuse you from the conditions of this License. If you cannot distribute so as to satisfy simultaneously your obligations under this License and any other pertinent obligations, then as a consequence you may not distribute the Program at all. For example, if a patent license would not permit royalty-free redistribution of the Program by all those who receive copies directly or indirectly through you, then the only way you could satisfy both it and this License would be to refrain entirely from distribution of the Program. If any portion of this section is held invalid or unenforceable under any particular circumstance, the balance of the section is intended to apply and the section as a whole is intended to apply in other circumstances. It is not the purpose of this section to induce you to infringe any patents or other property right claims or to contest validity of any such claims; this section has the sole purpose of protecting the integrity of the free software distribution system, which is implemented by public license practices. Many people have made generous contributions to the wide range of software distributed through that system in reliance on consistent application of that system; it is up to the author/donor to decide if he or she is willing to distribute software through any other system and a licensee cannot impose that choice. This section is intended to make thoroughly clear what is believed to be a consequence of the rest of this License. 8. If the distribution and/or use of the Program is restricted in certain countries either by patents or by copyrighted interfaces, the original copyright holder who places the Program under this License may add an explicit geographical distribution limitation excluding those countries, so that distribution is permitted only in or among countries not thus excluded. In such case, this License incorporates the limitation as if written in the body of this License. 9. The

Free Software Foundation may publish revised and/or new versions of the General Public License from time to time. Such new versions will be similar in spirit to the present version, but may differ in detail to address new problems or concerns. Each version is given a distinguishing version number. If the Program specifies a version number of this License which applies to it and \"any later version\", you have the option of following the terms and conditions either of that version or of any later version published by the Free Software Foundation. If the Program does not specify a version number of this License, you may choose any version ever published by the Free Software Foundation.

10. If you wish to incorporate parts of the Program into other free programs whose distribution conditions are different, write to the author to ask for permission. For software which is copyrighted by the Free Software Foundation, write to the Free Software Foundation; we sometimes make exceptions for this. Our decision will be guided by the two goals of preserving the free status of all derivatives of our free software and of promoting the sharing and reuse of software generally.

NO WARRANTY

11. BECAUSE THE PROGRAM IS LICENSED FREE OF CHARGE, THERE IS NO WARRANTY FOR THE PROGRAM, TO THE EXTENT PERMITTED BY APPLICABLE LAW. EXCEPT WHEN OTHERWISE STATED IN WRITING THE COPYRIGHT HOLDERS AND/OR OTHER PARTIES PROVIDE THE PROGRAM \"AS IS\" WITHOUT WARRANTY OF ANY KIND, EITHER EXPRESSED OR IMPLIED, INCLUDING, BUT NOT LIMITED TO, THE IMPLIED WARRANTIES OF MERCHANTABILITY AND FITNESS FOR A PARTICULAR PURPOSE. THE ENTIRE RISK AS TO THE QUALITY AND PERFORMANCE OF THE PROGRAM IS WITH YOU. SHOULD THE PROGRAM PROVE DEFECTIVE, YOU ASSUME THE COST OF ALL NECESSARY SERVICING, REPAIR OR CORRECTION.

12. IN NO EVENT UNLESS REQUIRED BY APPLICABLE LAW OR AGREED TO IN WRITING WILL ANY COPYRIGHT HOLDER, OR ANY OTHER PARTY WHO MAY MODIFY AND/OR REDISTRIBUTE THE PROGRAM AS PERMITTED ABOVE, BE LIABLE TO YOU FOR DAMAGES, INCLUDING ANY GENERAL, SPECIAL, INCIDENTAL OR CONSEQUENTIAL DAMAGES ARISING OUT OF THE USE OR INABILITY TO USE THE PROGRAM (INCLUDING BUT NOT LIMITED TO LOSS OF DATA OR DATA BEING RENDERED INACCURATE OR LOSSES SUSTAINED BY YOU OR THIRD PARTIES OR A FAILURE OF THE PROGRAM TO OPERATE WITH ANY OTHER PROGRAMS), EVEN IF SUCH HOLDER OR OTHER PARTY HAS BEEN ADVISED OF THE POSSIBILITY OF SUCH DAMAGES.

END OF TERMS AND CONDITIONS

How to Apply These Terms to Your New Programs

If you develop a new program, and you

want it to be of the greatest possible use to the public, the best way to achieve this is to make it free software which everyone can redistribute and change under these terms. To do so, attach the following notices to the program. It is safest to attach them to the start of each source file to most effectively convey the exclusion of warranty; and each file should have at least the \"copyright\" line and a pointer to where the full notice is found. one line to give the program's name and an idea of what it does.

Copyright (C) yyyy name of author This program is free software; you can redistribute it and/or modify it under the terms of the GNU General Public License as published by the Free Software Foundation; either version 2 of the License, or (at your option) any later version. This program is distributed in the hope that it will be useful, but WITHOUT ANY WARRANTY; without even the implied warranty of MERCHANTABILITY or FITNESS FOR A PARTICULAR PURPOSE. See the GNU General Public License for more details. You should have received a copy of the GNU General Public License along with this program; if not, write to the Free Software Foundation, Inc., 59 Temple Place - Suite 330, Boston, MA 02111-1307, USA. Also add information on how to contact you by electronic and paper mail. If the program is interactive, make it output a short notice like this when it starts in an interactive mode: Gnomovision version 69, Copyright (C) year name of author Gnomovision comes with ABSOLUTELY NO WARRANTY; for details type `show w`. This is free software, and you are welcome to redistribute it under certain conditions; type `show c` for details. The hypothetical commands `show w` and `show c` should show the appropriate parts of the General Public License. Of course, the commands you use may be called something other than `show w` and `show c`; they could even be mouse-clicks or menu items--whatever suits your program. You should also get your employer (if you work as a programmer) or your school, if any, to sign a \"copyright disclaimer\" for the program, if necessary. Here is a sample; alter the names: Yoyodyne, Inc., hereby disclaims all copyright interest in the program `Gnomovision` (which makes passes at compilers) written by James Hacker. signature of Ty Coon, 1 April 1989 Ty Coon, President of Vice This General Public License does not permit incorporating your program into proprietary programs. If your program is a subroutine library, you may consider it more useful to permit linking proprietary applications with the library. If this is what you want to do, use the GNU Lesser General Public License instead of this License.

END OF TERMS AND CONDITIONS

OpenSSL

The following component is licensed under OpenSSL license:

OpenSSL 0.9.7b

OpenSSL License

```
/* =====
 * Copyright (c) 1998-2008 The OpenSSL Project. All rights reserved.
 *
 * Redistribution and use in source and binary forms, with or without
 * modification, are permitted provided that the following conditions are met:
 *
 * 1. Redistributions of source code must retain the above copyright
 * notice, this list of conditions and the following disclaimer.
 *
 * 2. Redistributions in binary form must reproduce the above copyright
 * notice, this list of conditions and the following disclaimer in the
 * documentation and/or other materials provided with the distribution.
 *
 * 3. All advertising materials mentioning features or use of this software
 * must display the following acknowledgment:
 *
 * "This product includes software developed by the OpenSSL Project
 * for use in the OpenSSL Toolkit. (http://www.openssl.org/)"
 *
 * 4. The names "OpenSSL Toolkit" and "OpenSSL Project" must not be
 * used to endorse or promote products derived from this software without
 * prior written permission. For written permission, please contact
 * openssl-core@openssl.org.
 *
 * 5. Products derived from this software may not be called "OpenSSL"
 * nor may "OpenSSL" appear in their names without prior written
 * permission of the OpenSSL Project.
 *
```

* 6. Redistributions of any form whatsoever must retain the following acknowledgment:

* "This product includes software developed by the OpenSSL Project for use in the OpenSSL Toolkit (<http://www.openssl.org/>)"

*

* THIS SOFTWARE IS PROVIDED BY THE OpenSSL PROJECT ``AS IS'' AND ANY EXPRESSED OR IMPLIED WARRANTIES, INCLUDING, BUT NOT LIMITED TO, THE IMPLIED WARRANTIES OF MERCHANTABILITY AND FITNESS FOR A PARTICULAR PURPOSE ARE DISCLAIMED. IN NO EVENT SHALL THE OpenSSL PROJECT OR ITS CONTRIBUTORS BE LIABLE FOR ANY DIRECT, INDIRECT, INCIDENTAL, SPECIAL, EXEMPLARY, OR CONSEQUENTIAL DAMAGES (INCLUDING, BUT NOT LIMITED TO, PROCUREMENT OF SUBSTITUTE GOODS OR SERVICES; LOSS OF USE, DATA, OR PROFITS; OR BUSINESS INTERRUPTION) HOWEVER CAUSED AND ON ANY THEORY OF LIABILITY, WHETHER IN CONTRACT, STRICT LIABILITY, OR TORT (INCLUDING NEGLIGENCE OR OTHERWISE) ARISING IN ANY WAY OUT OF THE USE OF THIS SOFTWARE, EVEN IF ADVISED OF THE POSSIBILITY OF SUCH DAMAGE.

* =====

*

* This product includes cryptographic software written by Eric Young (eay@cryptsoft.com). This product includes software written by Tim Hudson (tjh@cryptsoft.com).

*

*/

Original SSLeay License

/* Copyright (C) 1995-1998 Eric Young (eay@cryptsoft.com)

* All rights reserved.

*

* This package is an SSL implementation written by Eric Young (eay@cryptsoft.com).

* The implementation was written so as to conform with Netscapes SSL.

*

* This library is free for commercial and non-commercial use as long as the following conditions are adhered to. The following conditions apply to all code found in this distribution, be it the RC4, RSA, lhash, DES, etc., code; not just the SSL code. The SSL documentation included with this distribution is covered by the same copyright terms except that the holder is Tim Hudson (tjh@cryptsoft.com).

*

* Copyright remains Eric Young's, and as such any Copyright notices in the code are not to be removed.

* If this package is used in a product, Eric Young should be given attribution as the author of the parts of the library used.

* This can be in the form of a textual message at program startup or in documentation (online or textual) provided with the package.

*

* Redistribution and use in source and binary forms, with or without modification, are permitted provided that the following conditions are met:

* 1. Redistributions of source code must retain the copyright notice, this list of conditions and the following disclaimer.

* 2. Redistributions in binary form must reproduce the above copyright notice, this list of conditions and the following disclaimer in the documentation and/or other materials provided with the distribution.

* 3. All advertising materials mentioning features or use of this software must display the following acknowledgement:

* "This product includes cryptographic software written by Eric Young (eay@cryptsoft.com)"

* The word 'cryptographic' can be left out if the routines from the library being used are not cryptographic related :-).

* 4. If you include any Windows specific code (or a derivative thereof) from the apps directory (application code) you must include an acknowledgement:

* "This product includes software written by Tim Hudson (tjh@cryptsoft.com)"

*

* THIS SOFTWARE IS PROVIDED BY ERIC YOUNG ``AS IS" AND ANY EXPRESS OR IMPLIED WARRANTIES, INCLUDING, BUT NOT LIMITED TO, THE IMPLIED WARRANTIES OF MERCHANTABILITY AND FITNESS FOR A PARTICULAR PURPOSE ARE DISCLAIMED. IN NO EVENT SHALL THE AUTHOR OR CONTRIBUTORS BE LIABLE FOR ANY DIRECT, INDIRECT, INCIDENTAL, SPECIAL, EXEMPLARY, OR CONSEQUENTIAL DAMAGES (INCLUDING, BUT NOT LIMITED TO, PROCUREMENT OF SUBSTITUTE GOODS OR SERVICES; LOSS OF USE, DATA, OR PROFITS; OR BUSINESS INTERRUPTION) HOWEVER CAUSED AND ON ANY THEORY OF LIABILITY, WHETHER IN CONTRACT, STRICT LIABILITY, OR TORT (INCLUDING NEGLIGENCE OR OTHERWISE) ARISING IN ANY WAY OUT OF THE USE OF THIS SOFTWARE, EVEN IF ADVISED OF THE POSSIBILITY OF SUCH DAMAGE.

*

* The licence and distribution terms for any publically available version or derivative of this code cannot be changed. i.e. this code cannot simply be copied and put under another distribution licence [including the GNU Public Licence.]

*/

END OF TERMS AND CONDITIONS

Zlib

The following component is licensed under zlib license:

Zlib 1.2.1

Zlib License

```
/* zlib.h -- interface of the 'zlib' general purpose compression library
version 1.2.4, March 14th, 2010
```

Copyright (C) 1995-2010 Jean-loup Gailly and Mark Adler

This software is provided 'as-is', without any express or implied warranty. In no event will the authors be held liable for any damages arising from the use of this software.

Permission is granted to anyone to use this software for any purpose, including commercial applications, and to alter it and redistribute it freely, subject to the following restrictions:

1. The origin of this software must not be misrepresented; you must not claim that you wrote the original software. If you use this software in a product, an acknowledgment in the product documentation would be appreciated but is not required.
2. Altered source versions must be plainly marked as such, and must not be misrepresented as being the original software.
3. This notice may not be removed or altered from any source distribution.

Jean-loup Gailly

Mark Adler

END OF TERMS AND CONDITIONS

Curl

The following component is licensed under curl license:

Curl 7.15.1

Curl License

COPYRIGHT AND PERMISSION NOTICE

Copyright (c) 1996 - 2010, Daniel Stenberg, <daniel@haxx.se>.

All rights reserved.

Permission to use, copy, modify, and distribute this software for any purpose with or without fee is hereby granted, provided that the above copyright notice and this permission notice appear in all copies.

THE SOFTWARE IS PROVIDED "AS IS", WITHOUT WARRANTY OF ANY KIND, EXPRESS OR IMPLIED, INCLUDING BUT NOT LIMITED TO THE WARRANTIES OF MERCHANTABILITY, FITNESS FOR A PARTICULAR PURPOSE AND NONINFRINGEMENT OF THIRD PARTY RIGHTS. IN NO EVENT SHALL THE AUTHORS OR COPYRIGHT HOLDERS BE LIABLE FOR ANY CLAIM, DAMAGES OR OTHER LIABILITY, WHETHER IN AN ACTION OF CONTRACT, TORT OR OTHERWISE, ARISING FROM, OUT OF OR IN CONNECTION WITH THE SOFTWARE OR THE USE OR OTHER DEALINGS IN THE SOFTWARE.

Except as contained in this notice, the name of a copyright holder shall not be used in advertising or otherwise to promote the sale, use or other

dealings in this Software without prior written authorization of the copyright holder.

END OF TERMS AND CONDITIONS

Libpng

The following component is licensed under libpng license:

Libpng 1.2.37 - June 4, 2009

Libpng License

This copy of the libpng notices is provided for your convenience. In case of any discrepancy between this copy and the notices in the file png.h that is included in the libpng distribution, the latter shall prevail.

COPYRIGHT NOTICE, DISCLAIMER, and LICENSE:

If you modify libpng you may insert additional notices immediately following this sentence.

libpng versions 1.2.6, August 15, 2004, through 1.2.34, December 18, 2008, are

Copyright (c) 2004, 2006-2008 Glenn Randers-Pehrson, and are distributed according to the same disclaimer and license as libpng-1.2.5 with the following individual added to the list of Contributing Authors

Cosmin Truta

libpng versions 1.0.7, July 1, 2000, through 1.2.5 - October 3, 2002, are Copyright (c) 2000-2002 Glenn Randers-Pehrson, and are distributed according to the same disclaimer and license as libpng-1.0.6 with the following individuals added to the list of Contributing Authors

Simon-Pierre Cadieux

Eric S. Raymond

Gilles Vollant

and with the following additions to the disclaimer:

There is no warranty against interference with your enjoyment of the library or against infringement. There is no warranty that our efforts or the library will fulfill any of your particular purposes or needs. This library is provided with all faults, and the entire risk of satisfactory quality, performance, accuracy, and effort is with the user.

libpng versions 0.97, January 1998, through 1.0.6, March 20, 2000, are Copyright (c) 1998, 1999 Glenn Randers-Pehrson, and are distributed according to the same disclaimer and license as libpng-0.96, with the following individuals added to the list of Contributing Authors:

Tom Lane

Glenn Randers-Pehrson

Willem van Schaik

libpng versions 0.89, June 1996, through 0.96, May 1997, are Copyright (c) 1996, 1997 Andreas Dilger

Distributed according to the same disclaimer and license as libpng-0.88, with the following individuals added to the list of Contributing Authors:

John Bowler

Kevin Bracey

Sam Bushell

Magnus Holmgren

Greg Roelofs

Tom Tanner

libpng versions 0.5, May 1995, through 0.88, January 1996, are Copyright (c) 1995, 1996 Guy Eric Schalnat, Group 42, Inc.

For the purposes of this copyright and license, "Contributing Authors" is defined as the following set of individuals:

Andreas Dilger

Dave Martindale

Guy Eric Schalnat

Paul Schmidt

Tim Wegner

The PNG Reference Library is supplied "AS IS". The Contributing Authors and Group 42, Inc. disclaim all warranties, expressed or implied, including, without limitation, the warranties of merchantability and of fitness for any purpose. The Contributing Authors and Group 42, Inc. assume no liability for direct, indirect, incidental, special, exemplary, or

consequential damages, which may result from the use of the PNG Reference Library, even if advised of the possibility of such damage.

Permission is hereby granted to use, copy, modify, and distribute this source code, or portions hereof, for any purpose, without fee, subject to the following restrictions:

1. The origin of this source code must not be misrepresented.
2. Altered versions must be plainly marked as such and must not be misrepresented as being the original source.
3. This Copyright notice may not be removed or altered from any source or altered source distribution.

The Contributing Authors and Group 42, Inc. specifically permit, without fee, and encourage the use of this source code as a component to supporting the PNG file format in commercial products. If you use this source code in a product, acknowledgment is not required but would be appreciated.

A "png_get_copyright" function is available, for convenient use in "about" boxes and the like:

```
printf("%s",png_get_copyright(NULL));
```

Also, the PNG logo (in PNG format, of course) is supplied in the files "pngbar.png" and "pngbar.jpg (88x31) and "pngnow.png" (98x31).

Libpng is OSI Certified Open Source Software. OSI Certified Open Source is a certification mark of the Open Source Initiative.

Glenn Randers-Pehrson

glennrp at users.sourceforge.net

December 18, 2008

END OF TERMS AND CONDITIONS

Kern_random

The following component is licensed under kern_random license:

Kern_random Copyright Theodore Ts'o, 1994, 1995. All rights reserved.

Kern-random License

.\n This code is derived from software contributed to Berkeley by Chris Torek. Redistribution and use in source and binary forms, with or without modification, are permitted provided that the following conditions are met:

.\n 1. Redistributions of source code must retain the above copyright notice, this list of conditions and the following disclaimer.

.\n 2. Redistributions in binary form must reproduce the above copyright notice, this list of conditions and the following disclaimer in the documentation and/or other materials provided with the distribution.

.\n 3. All advertising materials mentioning features or use of this software must display the following acknowledgement:

.\n "This product includes software developed by the University of California, Berkeley and its contributors.

.\n 4. Neither the name of the University nor the names of its contributors may be used to endorse or promote products derived from this software without specific prior written permission.

.\n

.\n THIS SOFTWARE IS PROVIDED BY THE REGENTS AND CONTRIBUTORS ``AS IS'' AND ANY EXPRESS OR IMPLIED WARRANTIES, INCLUDING, BUT NOT LIMITED TO, THE IMPLIED WARRANTIES OF MERCHANTABILITY AND FITNESS FOR A PARTICULAR PURPOSE ARE DISCLAIMED. IN NO EVENT SHALL THE REGENTS OR CONTRIBUTORS BE LIABLE FOR ANY DIRECT, INDIRECT, INCIDENTAL, SPECIAL, EXEMPLARY, OR CONSEQUENTIAL DAMAGES (INCLUDING, BUT NOT LIMITED TO, PROCUREMENT OF SUBSTITUTE GOODS OR SERVICES; LOSS OF USE, DATA, OR PROFITS; OR BUSINESS INTERRUPTION) HOWEVER CAUSED AND ON ANY THEORY OF LIABILITY, WHETHER IN CONTRACT, STRICT LIABILITY, OR TORT (INCLUDING NEGLIGENCE OR OTHERWISE) ARISING IN ANY WAY OUT OF THE USE OF THIS SOFTWARE, EVEN IF ADVISED OF THE POSSIBILITY OF SUCH DAMAGE.

.\n

END OF TERMS AND CONDITIONS

ConvertUTF

The following component is licensed under convert UTF license:

Convert UTF

ConvertUTF License

Copyright 2001-2004 Unicode, Inc.

Disclaimer

This source code is provided as is by Unicode, Inc. No claims are made as to fitness for any particular purpose. No warranties of any kind are expressed or implied. The recipient agrees to determine applicability of information provided. If this file has been purchased on magnetic or optical media from Unicode, Inc., the sole remedy for any claim will be exchange of defective media within 90 days of receipt.

Limitations on Rights to Redistribute This Code

Unicode, Inc. hereby grants the right to freely use the information supplied in this file in the creation of products supporting the Unicode Standard, and to make copies of this file in any form for internal or external distribution as long as this notice remains attached.

END OF TERMS AND CONDITIONS

Wchar functions

The following component is licensed under wchar functions license:

Wchar functions

Wchar functions License

.\" Copyright (c) 1990, 1991, 1993

.\"The Regents of the University of California. All rights reserved.

.\"

Copyright (c) <YEAR>, <OWNER>

All rights reserved.

Redistribution and use in source and binary forms, with or without modification, are permitted provided that the following conditions are met:

Redistributions of source code must retain the above copyright notice, this list of conditions and the following disclaimer.

Redistributions in binary form must reproduce the above copyright notice, this list of conditions and the following disclaimer in the documentation and/or other materials provided with the distribution.

Neither the name of the <ORGANIZATION> nor the names of its contributors may be used to endorse or promote products derived from this software without specific prior written permission.

THIS SOFTWARE IS PROVIDED BY THE COPYRIGHT HOLDERS AND CONTRIBUTORS "AS IS" AND ANY EXPRESS OR IMPLIED WARRANTIES, INCLUDING, BUT NOT LIMITED TO, THE IMPLIED WARRANTIES OF MERCHANTABILITY AND FITNESS FOR A PARTICULAR PURPOSE ARE DISCLAIMED. IN NO EVENT SHALL THE COPYRIGHT HOLDER OR CONTRIBUTORS BE LIABLE FOR ANY DIRECT, INDIRECT, INCIDENTAL, SPECIAL, EXEMPLARY, OR CONSEQUENTIAL DAMAGES (INCLUDING, BUT NOT LIMITED TO, PROCUREMENT OF SUBSTITUTE GOODS OR SERVICES; LOSS OF USE, DATA, OR PROFITS; OR BUSINESS INTERRUPTION) HOWEVER CAUSED AND ON ANY THEORY OF LIABILITY, WHETHER IN CONTRACT, STRICT LIABILITY, OR TORT (INCLUDING NEGLIGENCE OR OTHERWISE) ARISING IN ANY WAY OUT OF THE USE OF THIS SOFTWARE, EVEN IF ADVISED OF THE POSSIBILITY OF SUCH DAMAGE

Libjpeg

END OF TERMS AND CONDITIONS

The following component is licensed under libjpeg license:

Libjpeg

Libjpeg License

This software is copyright (C) 1991-1998, Thomas G. Lane.

All Rights Reserved except as specified below.

Permission is hereby granted to use, copy, modify, and distribute this software (or portions thereof) for any purpose, without fee, subject to these conditions:

(1) If any part of the source code for this software is distributed, then this README file must be included, with this copyright and no-warranty notice unaltered; and any additions, deletions, or changes to the original files must be clearly indicated in accompanying documentation.

(2) If only executable code is distributed, then the accompanying documentation must state that "this software is based in part on the work of the Independent JPEG Group".

(3) Permission for use of this software is granted only if the user accepts full responsibility for any undesirable consequences; the authors accept NO LIABILITY for damages of any kind.

These conditions apply to any software derived from or based on the IJG code, not just to the unmodified library. If you use our work, you ought to acknowledge us.

Permission is NOT granted for the use of any IJG author's name or company name in advertising or publicity relating to this software or products derived from it. This software may be referred to only as "the Independent JPEG Group's software".

We specifically permit and encourage the use of this software as the basis of commercial products, provided that all warranty or liability claims are assumed by the product vendor.

END OF TERMS AND CONDITIONS

Terms you should know

Avaya Communication Server 1000

Your office communication system.

Calling Party Name Display

Information appearing on the LCD display screen, such as the caller's name and telephone number. The system must have CPND enabled.

Category 5 (Cat5)

Cable and associated connecting hardware capable of transmitting at speeds up to 100 MHz, used by 10BaseT, 100BaseT4, 100BaseTX.

Category 5e (Cat5e)

Most Cat5 cable manufactured after 1996 also supports 1000BaseT (GigE) installations, and is designated Cat 5e. Cat5e cable normally has four pairs of copper wire.

Category 6 (Cat6)

Cable and associated connecting hardware capable of transmitting at speeds up to 200 MHz. Designed specifically to support 1000BaseT (Gig Ethernet (GigE)), it is also compatible with 10BaseT, 100BaseT4, and 100BaseTX installations. The cable normally has four pairs of copper wire.

Date/time display

The current date and time when the telephone is in an idle state.

Directory Number (DN)

A number consisting of one to seven digits for a telephone, and also known as an *extension number*.

Feature display

An area that shows status information about the feature in use. It also displays the name and status of the active session.

Feature Status Lamp indicator

An LCD or an LED that indicates a data message, contact, or feature status by a flash, wink, steady on, or off.

Fixed key

The hard-labeled keys on your telephone.

Flexible Feature Codes (FFC)

Specialized codes entered using the dialpad that enable features (for example, Ring Again).

Goodbye key

A fixed key used to end an active call.

Indicator

An LCD or an LED that indicates the status of a feature by the flash, wink, steady on, or off.

Information display

Any display of call activity, lists, prompts, and status of calls. On your Avaya 1110 IP Deskphone, this information area is one line of text and symbols. If a text message exceeds this area, a scroll arrow icon indicates that you must use the scroll keys to view the remaining text.

Information line

A one-line by 24-character area that displays date and time or application information.

Interrupted dial tone

A broken or pulsed dial tone that sounds when you access some features on your telephone.

Message/Inbox

A fixed key on your Avaya 1110 IP Deskphone that connects to your voice messaging system when the key is pressed.

Navigation keys

Keys used to scroll through menus and lists appearing on the LCD display screen.

Off-hook

Any line selected to make a call or receive an incoming call. The term *off-hook* is applied when (a) the end-user lifts up the handset, (b) the end-user presses a line key, (c) the call is automatically answered at the telephone, or (d) a line is automatically selected for an outgoing call.

Paging tone

A special tone (two beeps followed by dial tone) that sounds when you use the Radio Paging feature.

Ringback/ring tone

A sound indicating that a call you have made is ringing at its destination.

Services key

A fixed key used to access options such as Telephone Options, Password Admin, Virtual Office Login, Virtual Office Logout, Test Local Mode, and Resume Normal Mode.

Shared Directory Number

A DN (extension) that is shared by two or more persons.

Special Prefix code (SPRE)

Special codes entered using the dialpad, followed by a two-digit access code, that enable features (for example, Call Forward All Calls requires entry of SPRE code + 74).

Soft keys

A set of keys programmed by your system administrator. These four keys, located directly below the display area, have four programmable layers. These keys are also used to configure parameters in the **Telephone Options** menu.

Special dial tone

The three consecutive tones followed by dial tone that you hear when accessing telephone features.

Station Control Password (SCPW)

Enables security features on your phone to prevent others from making calls from your telephone and to prevent access to protected features (for example, Remote Call Forward).

Status Messages

A message displayed to inform the user of important information. A right arrow appears if more than one Status Message is present. Examples of Status Messages include: Message Waiting, All Lines Forwarded to: 6453, Do Not Disturb On, Ring Again active, and Ringer is OFF.

System or Switch

Your office communication system.

Switchhook

A button on which the handset presses down, disconnecting your call when you replace the handset. The handset (when lifted) releases the switchhook, and you either answer an incoming call or you receive a dial tone to make a call.

User interface

Screen displays that interact with the end user as a result of an action or event.

Visual Alerter/Message Waiting indicator

An LCD or an LED that flashes to indicate that a message is waiting or when the ringer is on.

Index

A

Adjusting the display screen contrast 34

Adjusting the volume 33

AutoDial Transfer 76

Automatic Wake-Up 102

C

Call features and Flexible Feature Codes 17

Call Forward 65

Call log options 41

Call Page 76

Call Page Connect 76

Call Park 61

Call party information 137

Calling 51

Calling Party Number 63

Camp-on, Forced 81

Charge a call or charge a forced call 77

Conference call 72

Configure Name Display format 39

Configuring call log options 41

Configuring Name Display format 39

Connect 25

Connecting the components 25

Contrast adjustment 34

D

Date/time display 137

Date/Time format 36

Directory Number 137

display areas 17

Display incoming calls 64

Display settings 47

DN 137

E

Electronic Lock 69

Enhanced Override 80

Entering and editing text

Editing text using the soft keys 22

Entering text using the USB keyboard 25

Ethernet Statistics 49

Expand to PC key 14

External server applications 106

F

Feature display 138

Fixed key 138

Flexible 107

Flexible Feature Code (FFC) 138

G

Goodbye key 14, 138

Group Call 73

H

Hold key 14

Hospitality features 102

I

Indicator status 138
Information display 138
Information line 138
Internal Call Forward 66
Interrupted dial tone 139
IP Network Statistics 49
IP Set&DHCP Information 49

L

Language display 35
Last Number Redial 55
LCD screen 17
License Information 50
License notification 17
Line (DN) 14
Local Area Network (LAN) 11
Local Diagnostics 49
Local mode 99
lower display area 17

M

Make Set Busy 75
Malicious Call Trace 64
Media encryption 25
Media Gateway 1000B 98
Meet - me page 84
Message (Inbox) key 16, 139
Message waiting indicator 14, 141
More key 13

N

Navigation keys 13, 139
Network Diagnostic Tools 49

Normal mode 98

O

Off-hook 139
Off-hook dialing 51
On-hook dialing 52
Override a busy signal 83

P

Paging tone 139
Place a call on hold 58
Predial feature 52
Privacy Release 83

R

Radio Page 84
Record a Calling Party Number 63
Regulatory and safety information 113
Remote Call Forward 67
Resume Normal Mode 100
Ring Again 53
Ringback/ring tone 139

S

Secure your telephone 69
Security features 19
Selecting a language 35
Selecting date/time format 36
Services key 15, 139
Shared Directory Numbers 139
Soft keys 13
Soft keys (self-labeled) 140
Special dial tone 140

Special Prefix code (SPRE) 140
Speed Call 56
SRTP media encryption 19
Station Control Password (SCPW)
19, 104, 140
 change your password 19
 turn Password Protection on or
 off 21
Status Messages 140
Switchhook 140
System or Switch 140
System Speed Call 57

T

Telephone controls 13
Telephone information 41
Test Local Mode 99
Timed Reminder Recall 60
Transfer a call 59

U

upper display area 17
USB keyboard
 function keys 24
User Interface 141

V

Viewing telephone information 41
Virtual Office 87
Virtual Office login 89
Virtual Office logout 95
Virtual Office on your Remote tele-
phone 90
Volume adjustment 33
Volume control 13

