

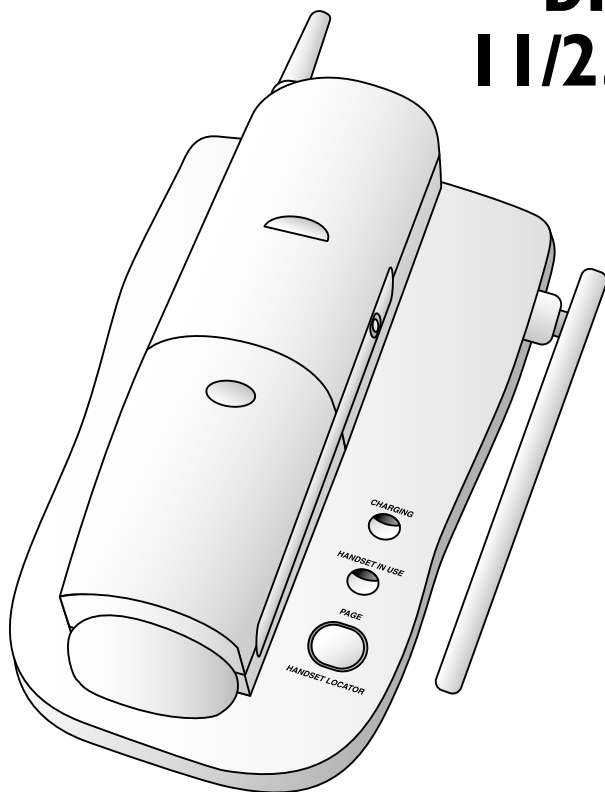

USER'S MANUAL
Part 2

900 MHz Cordless Telephone 6100

DRAFT
11/25/00



For Customer Service Or Product
Information, Visit Our Website At
www.telephones.att.com

Please also read
**Part 1 — Important
Product Information**

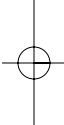
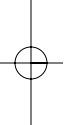

CONTENTS

INSTALLATION3

- Before You Install 3
- Table/Desk Installation 4
- Wall Installation 6

TELEPHONE OPERATION8

- Make or Answer a Regular
Phone Call 8
- Access Internet Calling 8
- Redial 8
- Change Channel 8
- Handset Volume 8
- Flash/Call Waiting 8
- Page/Handset Locator 9
- Making Internet Calls 10
- Handset Ringer Style 10
- Ringer Off/Battery Save 10
- Headset Jack 11
- Operating Range 11

TELEPHONE MEMORY12

- Store Memory Numbers 12
- Change/Replace a Stored
Memory Number 12
- Dial Memory Numbers 12
- Store a Pause in a
Memory Number 12
- Directory Label 12

BATTERIES13

- Charging the Handset
Battery Pack 13
- Replacing the Handset
Battery Pack 14

IN CASE OF DIFFICULTY 15

INSTALLATION

Before You Install

- 1 Choose a location for the base near an electrical outlet and a telephone jack.

This phone requires a modular telephone jack and a standard electrical outlet (110v AC) not controlled by a wall switch.

- 2 Install the handset battery.

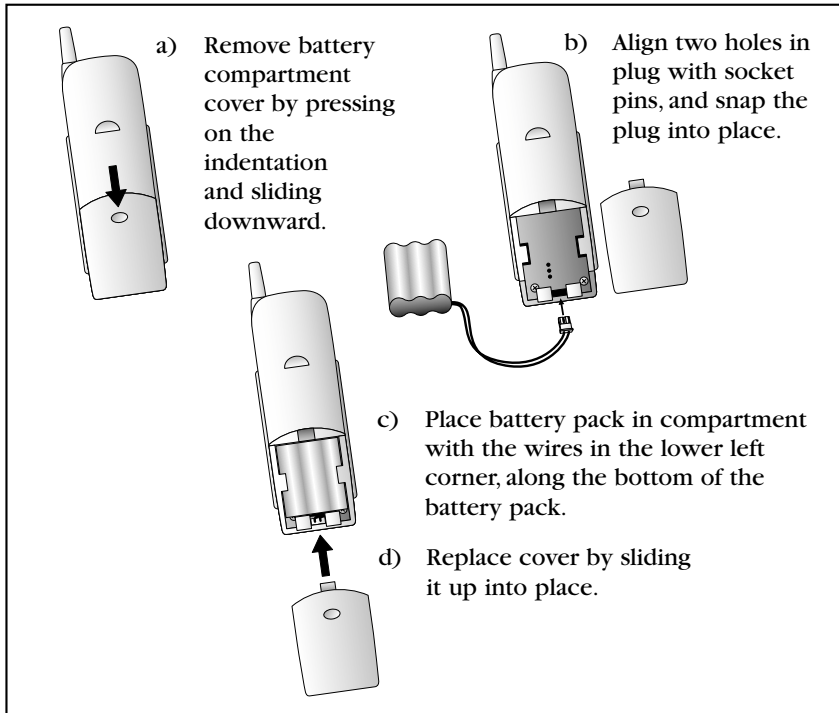

- 3 Attach the belt clip to the cordless handset (*optional*).

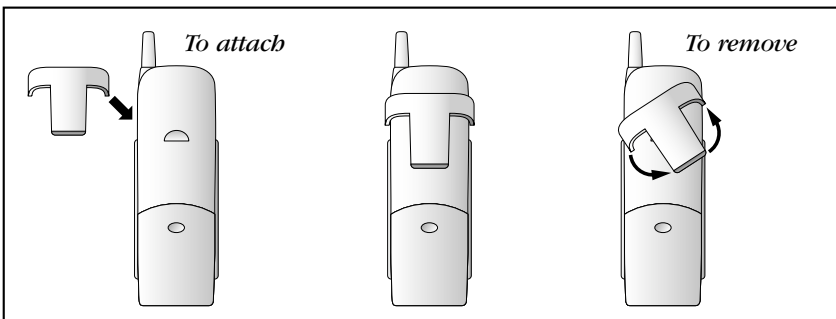

INSTALLATION

Table/Desk Installation

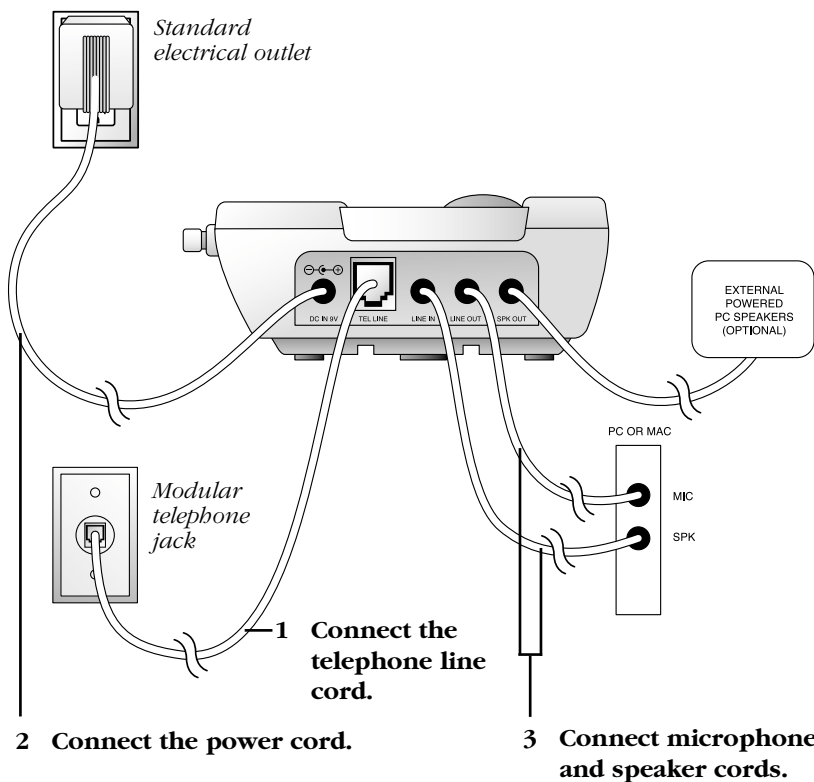

INSTALLATION

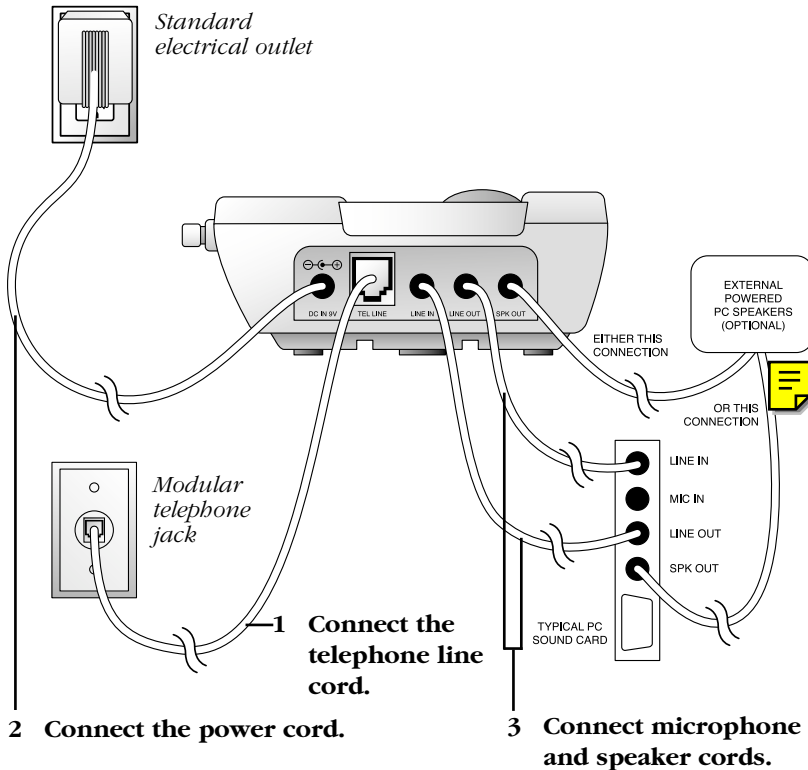

4 Charge the handset battery.

Place the handset in the base. Charge the battery for at least 24 hours the first time. After the first charge, the battery is typically fully charged overnight.

5 Check for dial tone.

After the batteries are charged, pick up the handset and press **PHONE**; you should hear a dial tone.

INSTALLATION

Wall Installation

- 1 Position the wall mount adapter on the base.

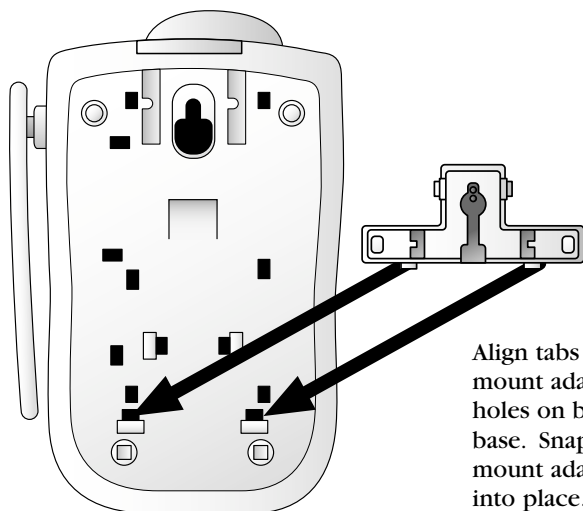

Align tabs on wall mount adapter with holes on bottom of base. Snap wall mount adapter firmly into place.

- 2 Connect the telephone line cord.
- 3 Connect the power cord.

INSTALLATION

4 Mount the base on the wall.

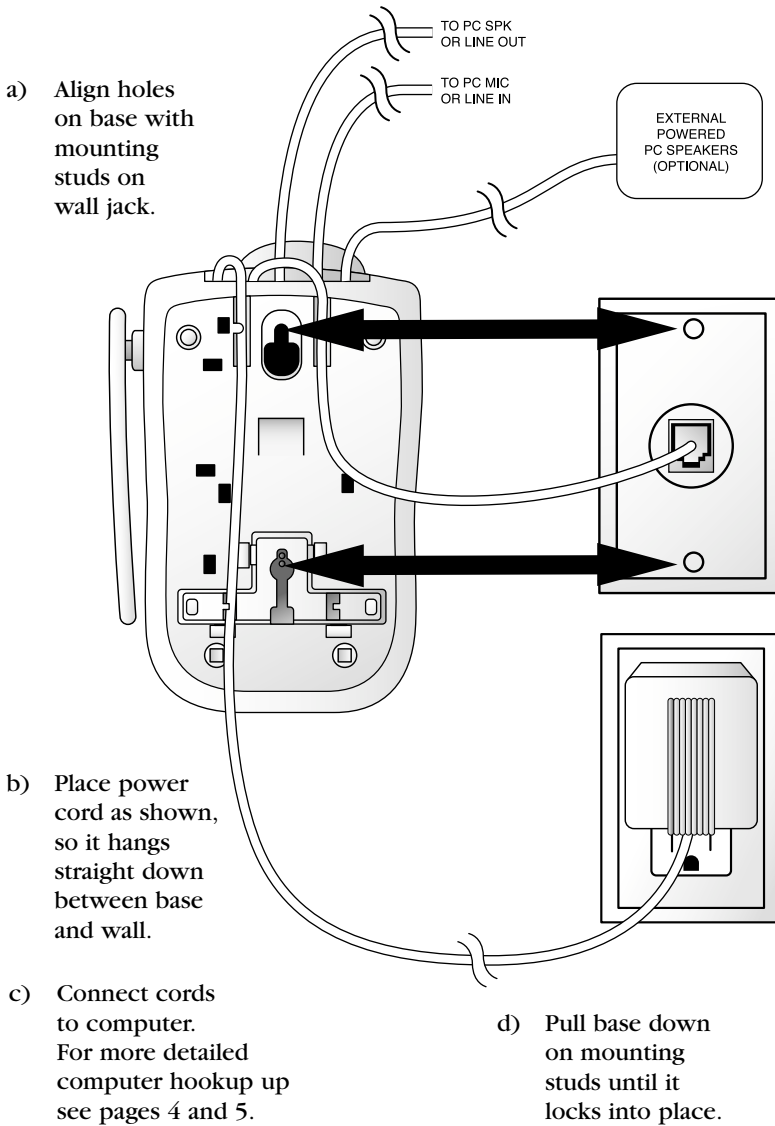

5 Follow Steps 4-5 in Table/Desk Installation.

TELEPHONE OPERATION

Handset Volume

Adjust volume of what you hear through the handset.

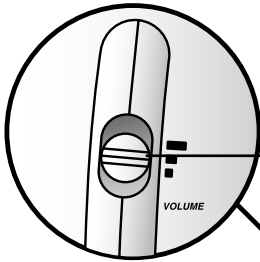

Make or Answer a Regular Phone Call

Lift handset from base
— OR —

Press **PHONE** and wait for light to go on steadily.

Flash/Call Waiting

Access special telephone company subscriber services.

Access Internet Calling

Red:

Regular phone call in progress.

Green:

Internet phone call in progress.



Red and Green or yellow):

Regular call and internet call in progress



Redial

Follow the instructions under "Make or Answer a Regular Phone Call," then press **REDIAL** to call the last number dialed (up to 24 digits).

Change Channel

Switch to a clearer channel while on a call.

TELEPHONE OPERATION

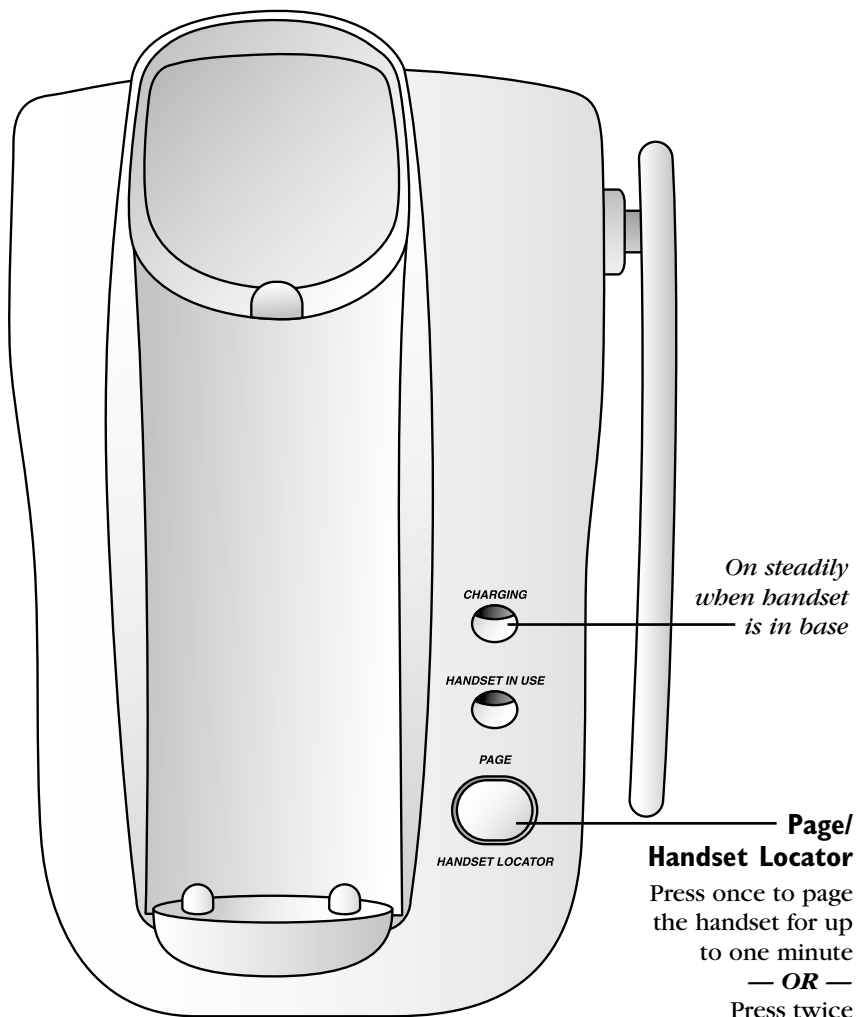

TELEPHONE OPERATION

Making Internet Calls

- Follow your internet calling provider's directions to establish a call.



Then press **VOIP** to connect the call to your handset.

If you receive a regular call while you're on an internet call, press

PHONE to take the call. Press **VOIP** to return to your internet call.



Handset Ringer Style

You can select from four different handset ringer styles.

- 1 Make sure the handset is off.
- 2 Press **PROG/MEM**, **#**.
- 3 Press **1**, **2**, **3** or **4** to select your ringer style. You will hear a sample of the ringer style.
- 4 Press **PROG/MEM**.

Ringer Off/Battery Save

- 1 Make sure the handset is off.
- 2 Press **PROG/MEM**, **#**.
- 3 Press **5**.
- 4 Press **PROG/MEM**.
- 5 To turn the ringer on again, see Handset Ringer Style.

TELEPHONE OPERATION

Headset Jack

You can use this telephone hands-free when you install a 2.5 mm headset (SKU 24099), purchased separately.

Plug the headset into the jack located on the right side of the handset (under the small rubber flap). Do not force the connection, but make sure the plug fits securely.

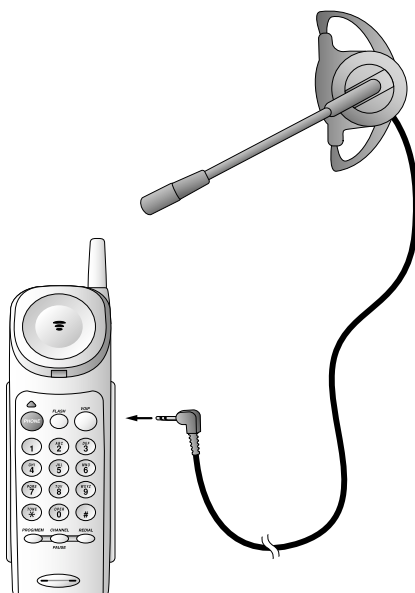

Operating Range

This cordless telephone operates within the maximum power allowed by the Federal Communications Commission (FCC). Even so, this handset and base can communicate over only a certain distance — which can vary with the locations of the base and handset, the weather, and the construction of your home or office. For best performance, keep the base antenna fully upright.

If you receive a call while you are out of range, the handset might not ring — or if it does ring, the call might not connect when you press **PHONE**. Move closer to the base, then press **PHONE** to answer the call.

If you move out of range during a phone conversation, you might hear noise or interference. To improve reception, move closer to the base.

If you move out of range without pressing OFF, your phone will be left “off the hook.” To hang up properly, walk back into range, periodically pressing **OFF**.

TELEPHONE MEMORY

This cordless phone can store 10 telephone numbers, each up to 16 digits long. You can dial numbers stored in memory just by pressing **PROG/MEM** and a number button.

Store Memory Numbers

- 1 Make sure the handset is off.
- 2 Press **PROG/MEM**.
The PHONE light blinks.
- 3 Press the number button (0-9) where you want to store the telephone number.
- 4 Dial the telephone number (up to 16 digits)
— **OR** —
Press **REDIAL** to store the last number dialed.
- 5 Press **PROG/MEM**.

Change/Replace a Stored Memory Number

Store a new number in its place.

Dial Memory Numbers

- 1 Press **PHONE**.
- 2 Press and release **PROG/MEM**, then press the number button (0-9) where the memory number is stored.



Store a Pause in a Memory Number

Press to store a two-second pause in the dialing sequence. Each press adds another two-second pause and counts as one digit.

Directory Label

Use the self-adhesive directory label to keep a record of the numbers (or names) stored in memory. It's best to write on the label before applying it to the phone.

BATTERIES

Charging the Handset Battery Pack

This battery should remain charged up to six days with the ringer turned on and up to 12 days with the ringer off. A fully charged battery provides an average talk time of about six hours.

The battery pack needs charging when:

- A new battery is installed in the handset.
- The phone beeps twice when you press **PHONE**.
- The phone light flashes slowly.

Place the handset in the base so the CHARGING light turns on. The battery pack is typically fully charged in eight hours.

You can keep the battery fully charged by returning the handset to the base after each use.

If you repeatedly get a low battery indicator, even after eight hours of charging, the battery should be replaced.

BATTERIES

Replacing the Handset Battery Pack

- 1 **Remove the battery compartment cover** on the handset by pressing on the indentation and sliding the cover downward.
- 2 **Lift out the old battery pack and disconnect.**
- 3 **Align the two holes in the new battery pack's plug** with the socket pins, and snap the plug into place. Place the battery pack in the compartment with the wires in the lower left corner, along the bottom of the battery pack.
- 4 **Replace the cover** by sliding it up into place.
- 5 **The new battery pack must be charged before using the phone.** Place the handset in the base and allow it to charge for at least 24 hours the first charge. The telephone might operate before that, but for best performance, let the battery pack charge fully.

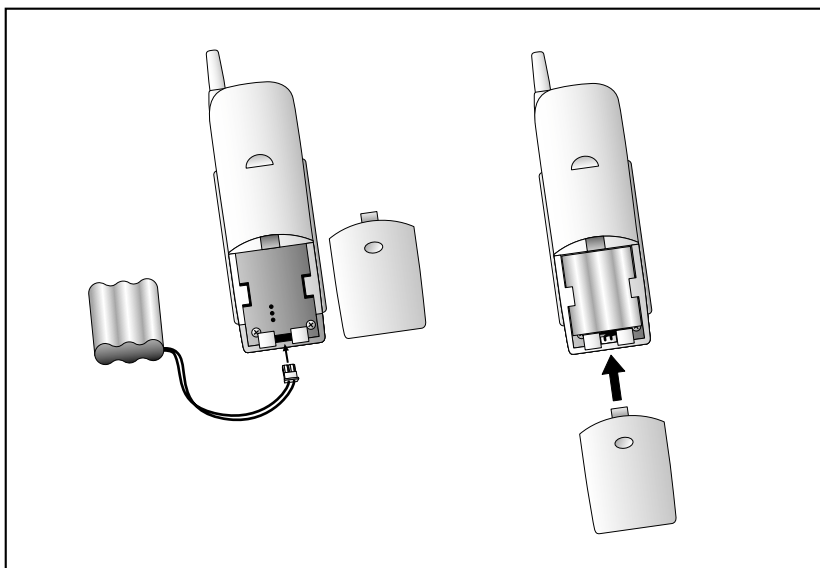

IN CASE OF DIFFICULTY

If you have difficulty operating this phone, try the suggestions below. For Customer Service, visit our website at www.telephones.att.com or call 1 800 222-3111. **Please retain your receipt as your proof of purchase.**

If the phone doesn't work at all, check these items first:

- Make sure the AC adapter is plugged into an outlet not controlled by a wall switch.
- Make sure the telephone line cord is plugged firmly into the base unit and the modular jack.
- Make sure the base antenna is fully upright.
- If the handset does not beep when you press **[PHONE]**, the battery might need charging.
- Make sure the battery pack is installed correctly.

If the above suggestions don't solve the problem, try re-initializing the handset and base:

- 1 Disconnect the power to the base.
- 2 Remove the handset battery pack.
- 3 Wait a few minutes.
- 4 Connect the power to the base.
- 5 Insert the handset battery pack.
- 6 Put the handset in the base to re-initialize.

If you hear a two-beep signal when you try to use the handset:

- You might be out of range. Move closer to the base and try again.
- If moving closer to the base doesn't help, try following the directions above for re-initializing the handset and base.

If the phone does not ring when you receive a call:

- Make sure the handset ringer is on.
- Make sure the telephone line cord is connected firmly to the base and the telephone jack.
- Make sure the AC adapter is plugged firmly into an outlet not controlled by a wall switch.
- You might be too far from the base; move closer.
- You might have too many extension phones on your telephone line to allow all of them to ring. Try unplugging some of them.

IN CASE OF DIFFICULTY

If you hear noise or interference when using the phone:

- Make sure the base antenna is fully upright.
- You may be out of range. Move closer to the base.
- Press and release **CHANNEL** to change to another of the 30 channels available. If noise is exceptionally loud, move closer to the base before changing channels.
- Household appliances plugged into the same circuit as the base can sometimes cause interference. Try moving the appliance or the base to another outlet.
- The layout of your home or office might be limiting the operating range. Try moving the base to another location, preferably on an upper floor.
- If the buttons don't work, try placing the handset in the base for at least 15 seconds.

If you hear other calls while using your phone:

- Press **CHANNEL** to change to another channel.
- Disconnect the base from the modular jack and plug in a corded telephone. If you still hear other calls, the problem is probably in your wiring or local service. Call your local telephone service company.

If you lose a call after changing channels:

You were probably almost out of range. Move closer to the base before changing channels. Before placing another call, set the handset in the base for at least 15 seconds.