

EX 945

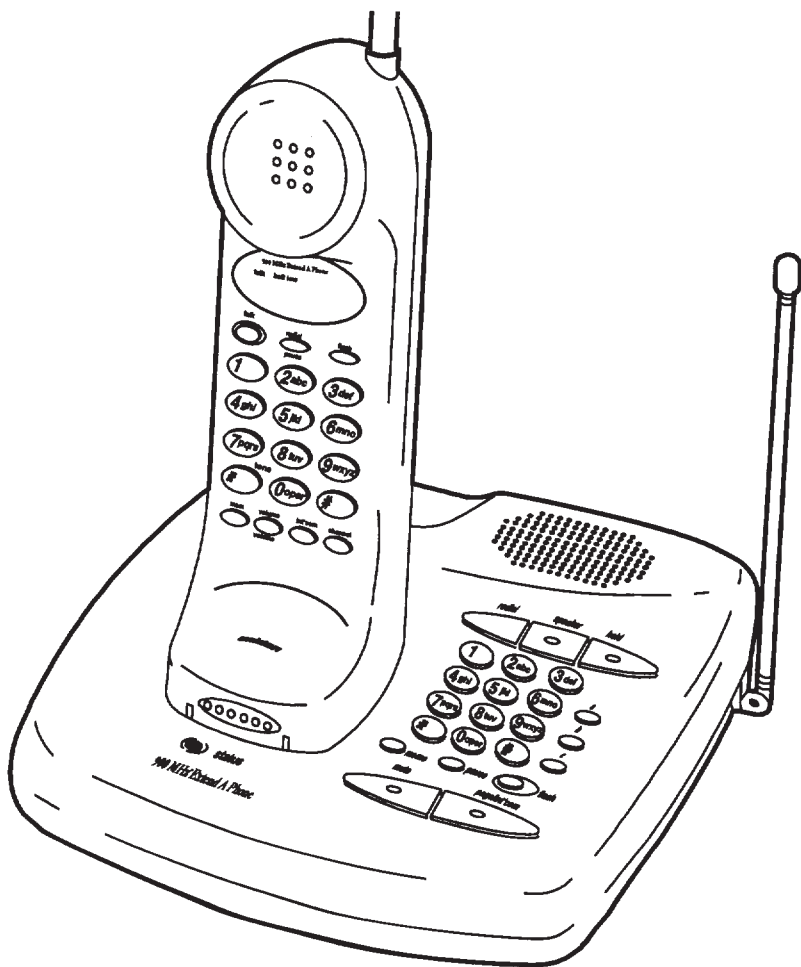

Operating Guide

900-MHz Cordless Extend-A-Phone[®]

PRECAUTIONS

Before you read anything else, please observe the following:

WARNING!

Uniden America Corporation **DOES NOT** represent this unit to be waterproof. To reduce the risk of fire, electrical shock, or damage to the unit, **DO NOT** expose this unit to rain or moisture.

RECHARGEABLE NICKEL-CADMIUM BATTERY WARNING

- This equipment contains a Rechargeable Nickel-Cadmium Battery.
- Cadmium is a chemical known to the State of California to cause cancer.
- The Rechargeable Nickel-Cadmium Battery contained in this equipment may explode if disposed of in a fire.
- **Do not** short-circuit the battery.
- **Do not** charge the Rechargeable Nickel-Cadmium Battery used in this equipment in any charger other than the one designed to charge this battery as specified in this Guide . Using another charger may damage the battery or cause the battery to explode.

RECHARGEABLE NICKEL-CADMIUM BATTERIES MUST BE RECYCLED OR DISPOSED OF PROPERLY

- Residents of Minnesota should contact 1-800-225-PRBA for information concerning reclamation and disposal of Rechargeable Nickel-Cadmium Batteries.
- Residents outside of Minnesota should contact their local authorities for information concerning reclamation and disposal of Rechargeable Nickel-Cadmium Batteries.



The exclamation point within an equilateral triangle is intended to alert the user to the presence of important operating and maintenance (servicing) instructions in the literature accompanying the appliance.

Controls and Functions

Handset

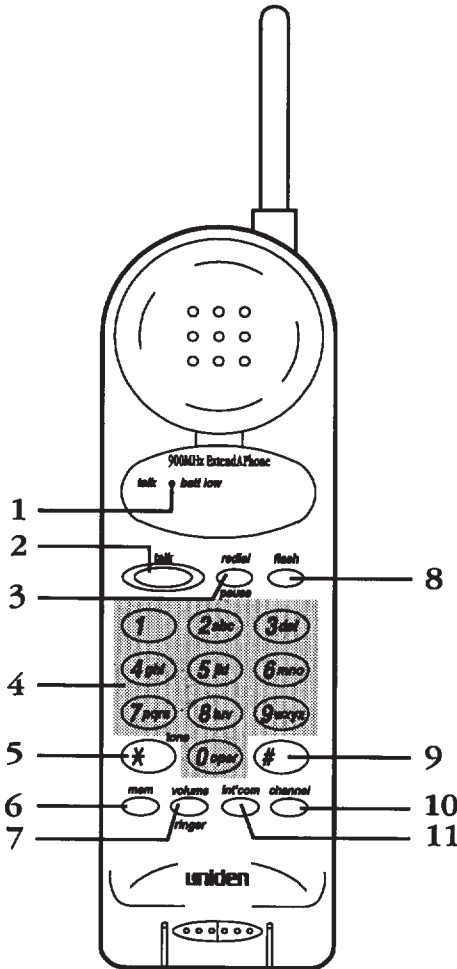

1. Talk/Battery Low Indicator
2. Talk Button *talk*
3. Redial/Pause Button *redial/pause*
4. Numeric Keypad
5. Star/Tone Button **/tone*
6. Memory Button *mem*
7. Volume/Ringer Button *volume/ringer*
8. Flash Button *flash*
9. Pound Key #
10. Channel Button *channel*
11. Intercom Button *int'com*

Controls and Functions

Base Unit

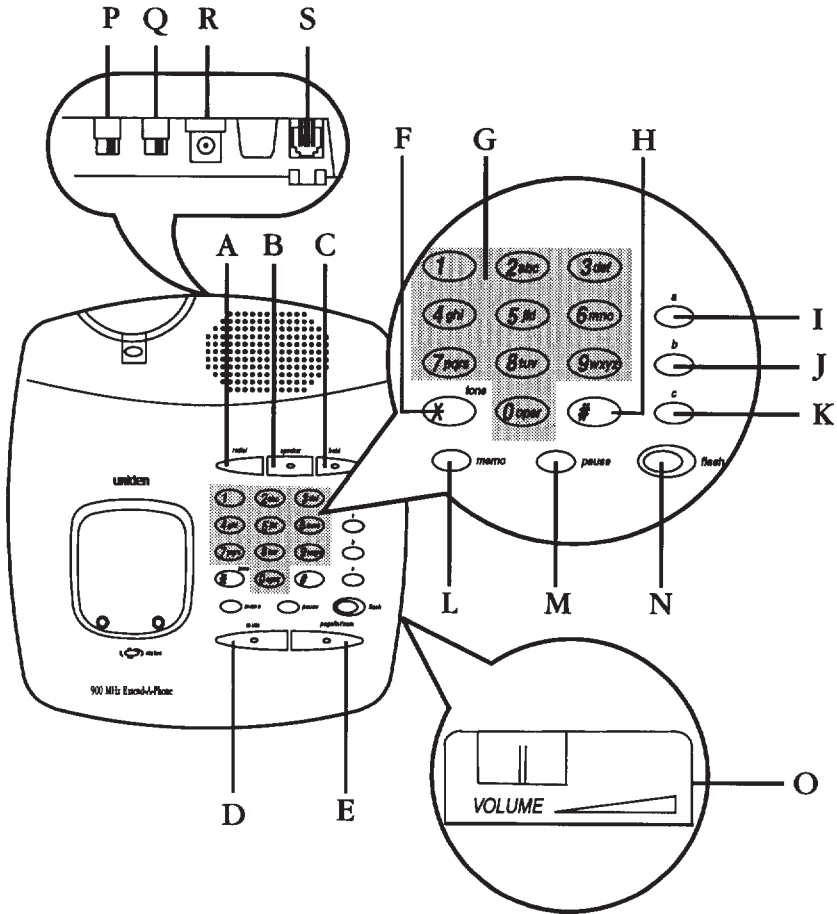

- | | | | |
|--------------------------------------|----------------------------|----------------------------|-----------------|
| A. Redial redial | F. Star/Tone *tone | K. One Touch Dial c | P. Ring Volume |
| B. Speaker speaker | G. Numeric Keypad | L. Memory memo | Q. Pulse - Tone |
| C. Hold hold | H. Pound Key # | M. Pause pause | R. DC Input |
| D. Mute mute | I. One Touch Dial a | N. Flash flash | S. Line Jack |
| E. Page/Intercom page/int'com | J. One Touch Dial b | O. Speaker Volume | |

CONTENTS

Important Safety Instructions	2
Battery Safety Precautions	3
Introduction	4
EX 945 Features	4
Included with the EX 945	5
Important Electrical Considerations	6
Range	6
Telephone Line Problems	6
Radio Interference	7
More Than One Cordless Telephone	7
Installation	8
Selecting a Location	8
Telephone Line Outlets	8
Connecting the Telephone Cords	8
Applying Power to the Base Unit	9
Adapter Safety Feature	9
Desk or Tabletop Installation	9
Wall Installation	13
Direct Wall Mounting	16
Setting the Handset Retainer	20
Setting Up Your Phone	21
Extending the Antenna	21
Installing the Handset Battery Pack	21
Installing the Beltclip	22
Removing the Beltclip	23
Charging the Battery Pack	24
Low Battery Indicator	25
Cleaning the Battery Contacts	26
Setting the Pulse-Tone Switch	27
Adjusting Ringer Controls	27
Automatic Digital Code Security	28
Programming Your EX 945	30
Storing Memory Dial Numbers	30
Storing Mixed Pulse/Tone Numbers	32
Erasing a Stored Number	33
Using Your EX 945	35
Answering a Call from the Base Unit	35
Answering a Call from the Handset	35
Making a Call from the Base Unit	35
Making a Call from the Handset	36
Dialing Stored Numbers	36
Chain Dialing	37
Placing a Call On Hold	38
Using the EX 945 with Call Waiting	38
Last Number Redial	38
Using your EX 945 Intercom	39
Mute Function	40
Troubleshooting	41
Specifications	43

Important Safety Instructions

When using your telephone equipment, these basic safety precautions should always be followed to reduce the risk of fire, electrical shock, and injury to persons:

1. Read and understand all instructions.
2. Follow all warnings and instructions marked on the product.
3. Unplug this product from the wall outlet before cleaning, and use a dry cloth, without liquid or aerosol cleaners.
4. Do not use this product near water; for example, near a bath tub, wash bowl, kitchen sink or laundry tub, in a wet basement, or near a swimming pool.
5. Do not place this product on an unstable cart, stand, or table. The telephone may fall, causing serious damage to the unit.
6. Slots and openings in the cabinet and the back or bottom are provided for ventilation. To protect the product from overheating, these openings must not be blocked or covered. This product should never be placed near or over a radiator or heat register. This product should not be placed in a built-in installation unless proper ventilation is provided.
7. This product should be operated only from the type of power source indicated on the marking label. If you are not sure of the type of power supply to your home, consult your dealer or local power company.
8. Do not allow anything to rest on the power cord. Do not locate this product where the cord will be damaged by persons walking on it.
9. Do not overload wall outlets and extension cords, as this can result in the risk of fire or electrical shock.
10. Never push objects of any kind into this product through cabinet slots, as they may touch dangerous voltage points or short out parts that could result in a risk of fire or electric shock. Never spill liquid of any kind on the product.
11. To reduce the risk of electric shock, do not disassemble this product. Take it to qualified service personnel when service or repair work is required. Opening or removing covers may expose you to dangerous voltages or other risks. Incorrect reassembly can cause electric shock when the appliance is subsequently used.

12. Unplug this product from the wall outlet and refer servicing to qualified service personnel under the following conditions:
 - A. When the power supply cord is damaged or frayed.
 - B. If liquid has been spilled into the product.
 - C. If the product has been exposed to rain or water.
 - D. If the product does not operate normally when following the operating instructions. (Adjust only those controls that are covered by the operating instructions. Improper adjustment of other controls may result in damage and will often require extensive repair work by a qualified technician.)
 - E. If the product has been dropped or the cabinet has been damaged.
 - F. If the product exhibits a distinct change in performance.
13. Do not use the telephone to report a gas leak in the vicinity of the leak.

Battery Safety Precautions

Caution: To reduce the risk of fire or injury to persons by the battery, read and follow these instructions:

1. Use only the appropriate type and size Battery Pack specified in this Operating Guide.
2. Do not dispose of the Battery Pack in a fire. The cell may explode. Check the Nickel-Cadmium Battery Disposal package insert for disposal instructions.
3. Do not open or mutilate the Battery Pack. Released electrolyte is corrosive and may cause damage to the eyes or skin. It may be toxic if swallowed.
4. Exercise care in handling the battery in order not to short the battery with conducting materials such as rings, bracelets, and keys. The battery or conductor may overheat and cause burns.
5. Charge the Battery Pack provided with or identified for use with this product only in accordance with the instructions and limitations specified in the instruction manual provided for this product.
6. Observe proper polarity orientation between the Battery Pack and battery charger.

SAVE THESE INSTRUCTIONS

Introduction

Congratulations on your purchase of the Uniden **EX 945** Cordless Telephone. The **EX 945** is designed and engineered to exacting standards for reliability, long life, and outstanding performance. To get the most from your **EX 945**, please read this Operating Guide thoroughly. Refer to the foldout located in front of this Operating Guide to help familiarize you with the features of your cordless phone. Also, be sure to fill out the Product Registration card at the back of this Guide, then detach and mail in.

EX 945 Features

- ▷ 900 Megahertz Performance
- ▷ Advanced Digital Performance
- ▷ Speakerphone
- ▷ Dual Keypad
- ▷ 30 Channel Autoscan System
- ▷ 20 Number Memory
- ▷ Page/Find System
- ▷ 14 Day Long Life Battery
- ▷ Redial

AutoTalk™ allows you to answer a call by just removing the handset from the Base so you don't have to waste time pushing buttons or flipping switches.

AutoStandby™ allows you hang up by simply returning the Handset to the Base.

The **UltraClear Plus** innovative technology, together with 30 different channels, virtually eliminates background noise and provides you with the best possible reception during all of your conversations.

To protect you against misbilled calls which might result from your phone being activated by other equipment, **Random Code™** digital security automatically selects one of over 65 thousand digital security codes for the Handset and Base Units. Also, the **AutoSecure™** feature electronically locks your phone when the Handset is in the Base.

To get the most from your phone, please read this Operating Guide thoroughly. Also be sure to complete the Product Registration form and mail it in.

Be sure to visit our Internet site at <http://www.uniden.com!>

Included with the EX 945

If any of these items are missing or damaged, contact Uniden Customer Service at: (800) 297-1023, 8:00 am to 5:00 pm Central, Monday through Friday



Handset

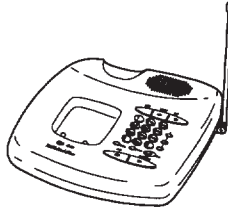

Base Unit

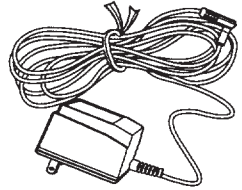

AC Adapter

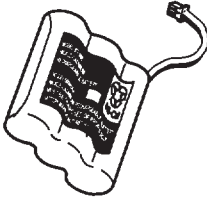

Battery

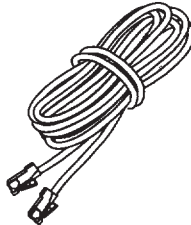

Long Telephone Cord

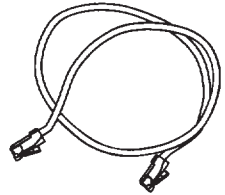

Short Telephone Cord

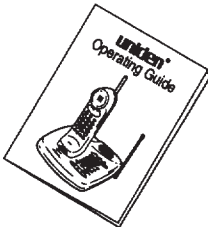

Operating Guide

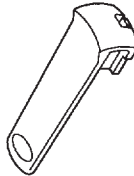

Belt Clip

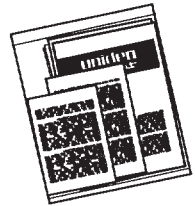

Other Printed Material

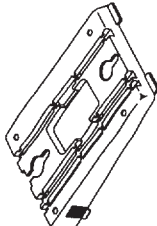

Wall Mount Stand

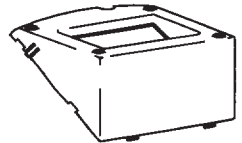

Desktop Stand

Important Electrical Considerations

Unplug all electrical appliances when you know an electrical storm is approaching. Lightning can pass through your household wiring and damage any device connected to it. This phone is no exception.

Please do not attempt to unplug any appliance during an electrical storm.

* *Changes or modifications to this product not expressly approved by Uniden, or operation of this product in any way other than as detailed by this Operating Guide, could void your authority to operate this product.*

Range

Your new phone is designed to achieve the maximum possible range by transmitting and receiving according to the highest specifications set forth by the FCC. We have rated this phone to operate at a maximum distance with the qualification that the range depends upon the environment in which the telephone is used. Many factors limit range, and it would be impossible to include all the variables in our rating. The Maximum Range rating of this phone is meant to be used as a means of comparison against other range claims.

Telephone Line Problems

The FCC has granted the telephone company the right to disconnect service in the event that your phone causes problems on the telephone line. Also, the telephone company may make changes in facilities and services which may affect the operation of your unit. However, your telephone company must give adequate notice in writing prior to such actions to allow you time for making necessary arrangements to continue uninterrupted service.

If you are having trouble with your telephone service, you must first disconnect your phone to determine if it is the cause of your problem. If you determine that it is the cause, you must leave it disconnected until the trouble has been corrected.

Radio Interference

Radio interference may occasionally cause buzzing and humming in your cordless Handset, or clicking noises in the Base Unit. This interference is caused by external sources such as TV, refrigerator, vacuum cleaner, fluorescent lighting, or electrical storm. Your unit is **NOT DEFECTIVE**. If these noises continue and are too distracting, please check around your home to see what appliances may be causing the problem. In addition, we recommend that the Base not be plugged into a circuit that also powers a major appliance because of the potential for interference. Be certain that the antenna on the unit is fully extended when needed.

In the unlikely event that you consistently hear other voices or distracting transmissions on your phone, you may be receiving radio signals from another cordless telephone or other source of interference. If you cannot eliminate this type of interference, you need to change to a different channel.

Finally, it should be noted that some cordless telephones operate at frequencies that may cause interference to nearby TVs and VCRs. To minimize or prevent such interference, the base of the cordless telephone should not be placed near or on top of a TV or VCR. If interference is experienced, moving the cordless telephone farther away from the TV or VCR will often reduce or eliminate the interference.

More Than One Cordless Telephone

If you want to use more than one cordless telephone in your home, they must operate on different channels. Press the channel key to select a channel that provides the clearest communication.

Installation

Selecting a Location

Before choosing a location for your new phone, there are some important guidelines you should consider:

- The location should be close to both a phone jack and continuous power outlet. (*A continuous power outlet is an AC outlet which does not have a switch to interrupt its power.*)
- Keep the Base Unit and Handset away from sources of electrical noise such as motors or fluorescent lighting.
- Be sure there is sufficient space to fully extend the Base Unit antenna.
- The Base Unit can be placed on a desk or tabletop or mounted on a standard AT&T or GTE wall plate.
- You should charge your new phone for 15-20 hours before completing the installation or using the Handset.

Telephone Line Outlets

There are two types of phone outlets:

Modular Jack

Most phone equipment available now uses modular jacks. Phone cords are fitted with a molded plastic connector which plugs into this type of jack. *If you do not have modular phone jacks, contact your local telephone company for information about their installation.*

Hard-wired Jack

Some equipment is wired directly to a phone jack, and these types of installations require a modular jack converter. *This type of installation is not difficult; however, you should contact your Uniden telephone dealer or a telephone supply store for advice about the proper adapter or converter for your particular situation.*

Connecting the Telephone Cords

Consider these safety guidelines before connecting the telephone cords:

- Never install telephone wiring during a lightning storm.
- Never touch uninsulated telephone wires or terminals unless the telephone line has been disconnected.
- Use caution when installing or modifying telephone lines.

Applying Power to the Base Unit

The **EX 945** phone requires an AC outlet, without a switch to interrupt power, and the included AC adapter. To relieve strain on the DC plug when the phone is placed on a desk or table, wrap the power cord around the convenient notch on the bottom.

*** Place the power cord so that it does not create a trip hazard, or where it could become chafed and create a fire or other electrical hazards.**

Adapter Safety Feature

The AC adapter furnished with this phone may be equipped with a polarized line plug — a plug having one blade wider than the other. This plug will fit into the power outlet only one way. If you are unable to insert the plug fully into the outlet, try reversing the plug.

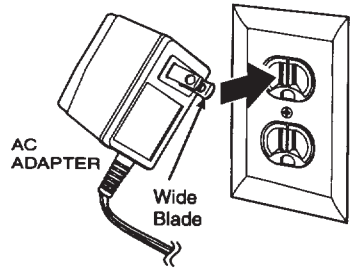

*** Do not alter the shape of the blades of the polarized plug.**

*** If you cannot plug the AC Adapter into the outlet, contact someone about replacing the outlet.**

Desk or Tabletop Installation

With the Desktop Stand

1. Slide the desktop stand into the notches at the top of the Base Unit, rotate the desktop stand down and snap it into place.

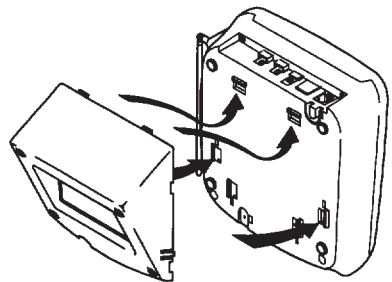

2. Plug the AC Adapter cord into the DC input jack on the Base Unit.

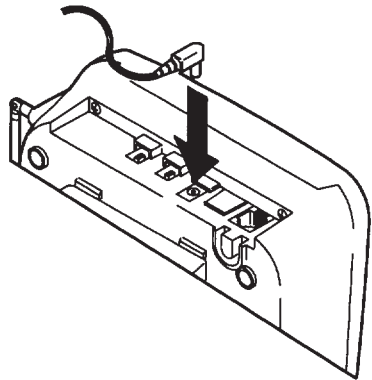

3. Place the AC Adapter cord around the strain relief.

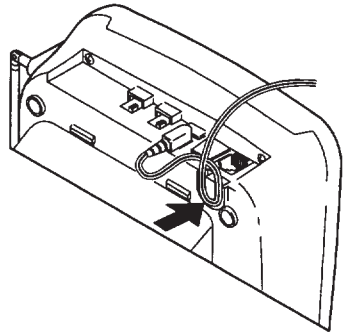

4. Plug one end of the long telephone cord into the **TEL LINE** jack on the Base Unit.

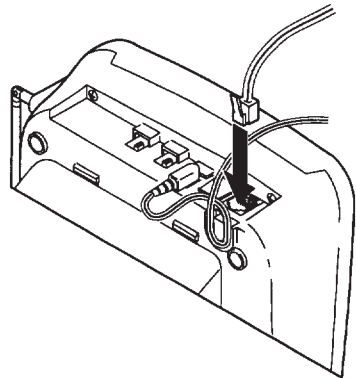

5. Plug the other end of the cord into the telephone jack on the wall.

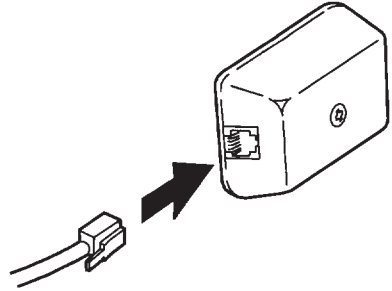

6. Plug the AC Adapter into a standard 120V AC wall outlet.

** Do not use an outlet controlled by a wall switch.*



Use only the Uniden AC Adapter supplied with this phone.

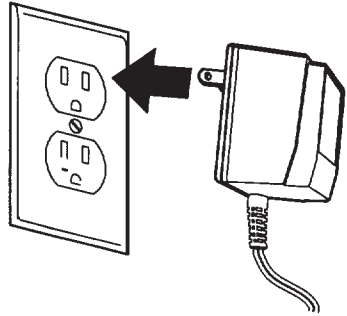

Without the Desktop Stand

1. Plug the AC Adapter cord into the DC input jack on the Base Unit.

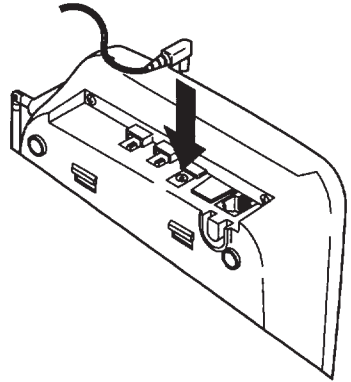

2. Place the AC Adapter cord around the strain relief.

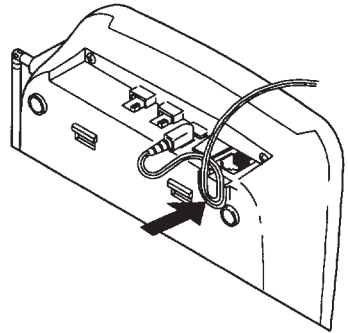

3. Plug one end of the long telephone cord into the **TEL LINE** jack on the Base Unit.

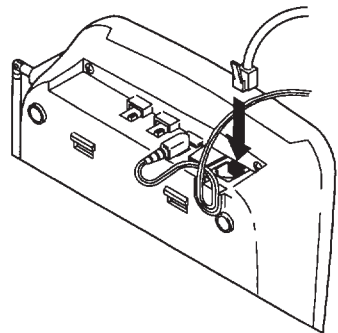

4. Plug the other end of the cord into the telephone jack on the wall.

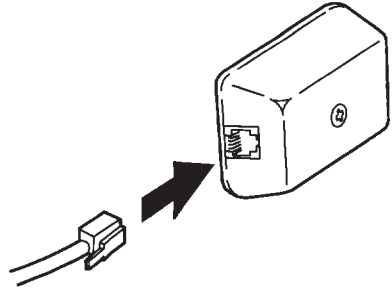

5. Plug the AC Adapter into a standard 120V AC wall outlet.

** Do not use an outlet controlled by a wall switch.*

Use only the Uniden AC Adapter supplied with this phone.

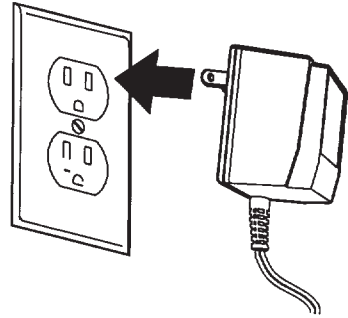

Wall Installation

Standard Wall Plate Mounting

These phones are designed to be mounted on a standard AT&T or GTE wall plate. To attach the wall mount stand to the Base Unit:

1. Slide the wall mount stand into the notches at the top of the Base Unit, rotate the wall mount stand down and snap it into place.

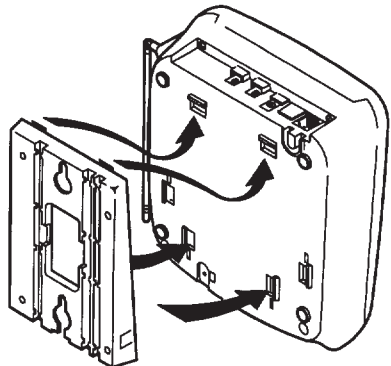

2. Plug the AC Adapter into the Base Unit.

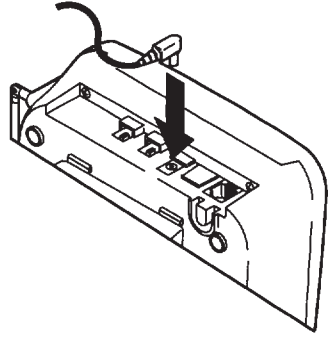

3. Wrap the AC Adapter cord around the strain relief on the Base Unit.

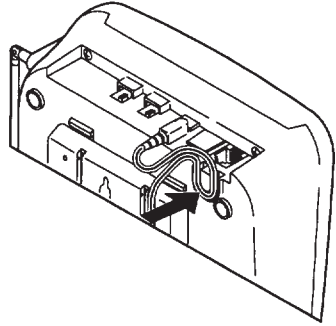

4. Place the AC Adapter cord inside the molded channel.

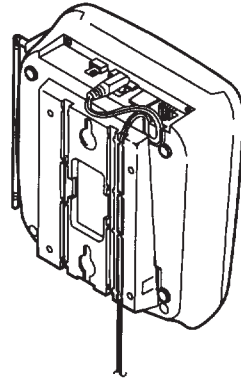

5. Plug one end of the short telephone cord into the **TEL LINE** jack on the Base Unit.

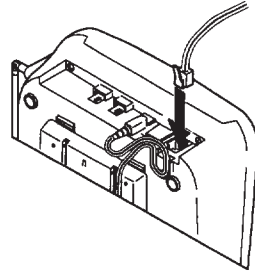

6. Place the telephone cord inside the molded channel on the bottom of the Base Unit.

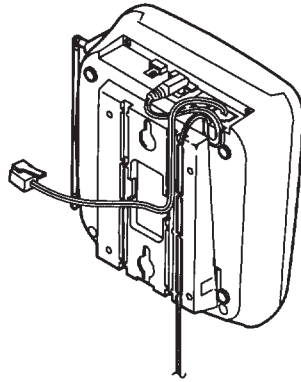

7. Then plug the other end of the telephone cord into the modular jack on the wall.

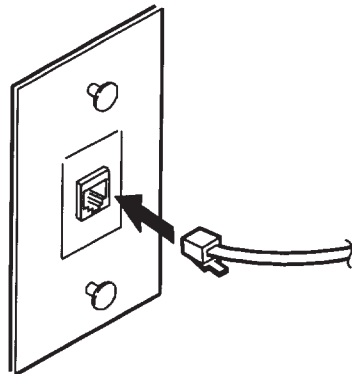

- Place the Base Unit on the posts of the wall plate and push down until it's firmly seated.

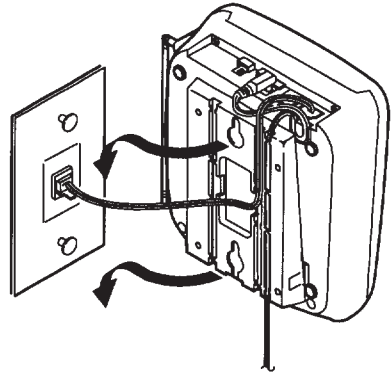

- Plug the AC Adapter into a standard 120V AC wall outlet.

** Do not use an outlet controlled by a wall switch.*

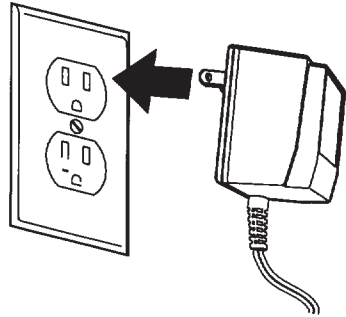

Direct Wall Mounting

If you do not have a standard wall plate, you can mount your phone directly on a wall. Before mounting your phone, consider the following:

- ▷ Select a location away from electrical cables, pipes, or other items behind the mounting location that could cause a hazard when inserting screws into the wall.
- ▷ Make sure the wall material is capable of supporting the weight of the Base Unit and Handset.
- ▷ Use #10 screws with anchoring devices suitable for the wall material where the Base Unit will be placed.

1. Insert two mounting screws $3\frac{15}{16}$ inches apart. Allow about $\frac{3}{16}$ of an inch between the wall and screw heads for mounting the phone.

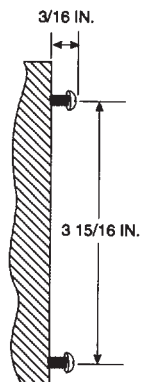

2. Plug the AC Adapter into the Base Unit.

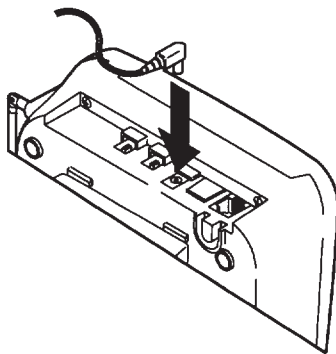

3. Wrap the AC Adapter cord around the strain relief on the Base Unit.

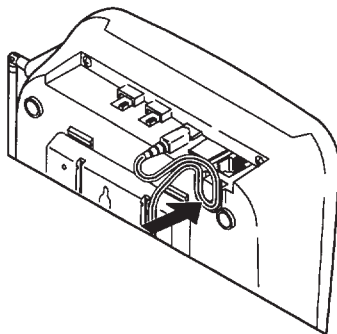

4. Place the AC Adapter cord inside the molded channel.

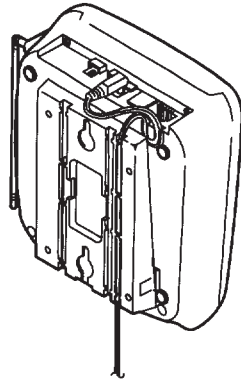

5. Plug one end of the long telephone cord into the **TEL LINE** jack on the Base Unit.

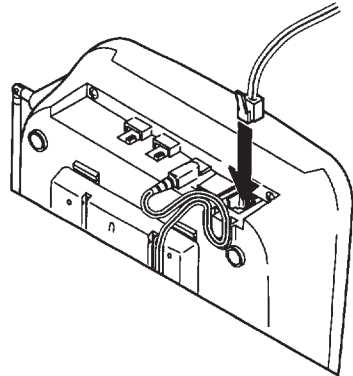

6. Place the cord inside the molded channel on the bottom of the Base Unit.

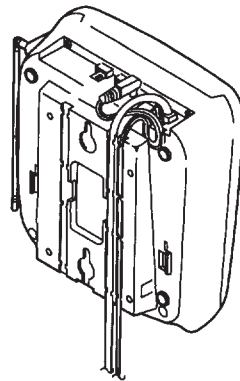

7. Place the Base Unit on the screws and push down until it's firmly seated.

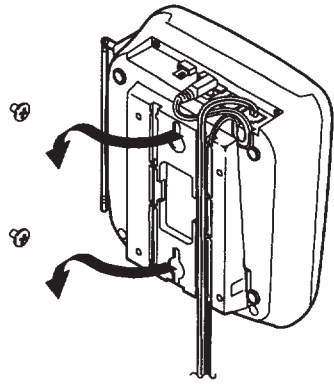

8. Plug the other end of the telephone line cord into the wall jack.

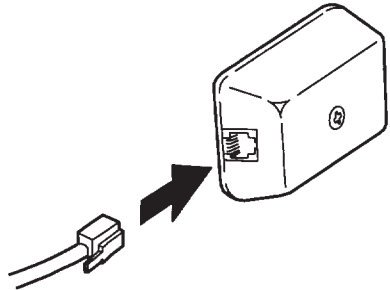

9. Plug the AC Adapter into a standard 120V AC wall outlet.

** Do not use an outlet controlled by a wall switch.*

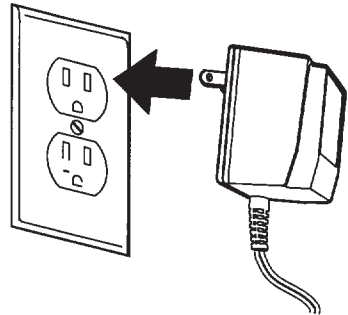

Setting the Handset Retainer

The Handset Retainer holds the Handset in place if your phone is mounted on a wall. These steps describe how to remove and replace the retainer so that the tab faces up.

1. Push up on the Handset Retainer on the Base Unit, and slide the tab out.

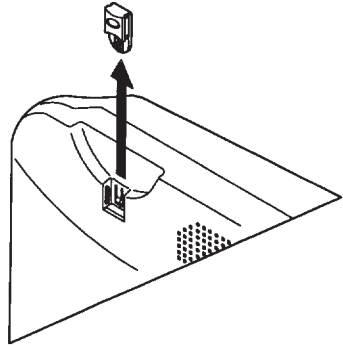

2. Flip the Retainer over so the tab faces up, then put the Retainer back into its slot on the Base Unit.

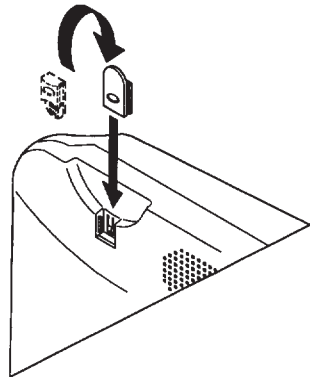

3. Push down on the Handset Retainer until it snaps into place.

Setting Up Your Phone

Extending the Antenna

Before using your phone, be sure to raise its antenna to the vertical position.

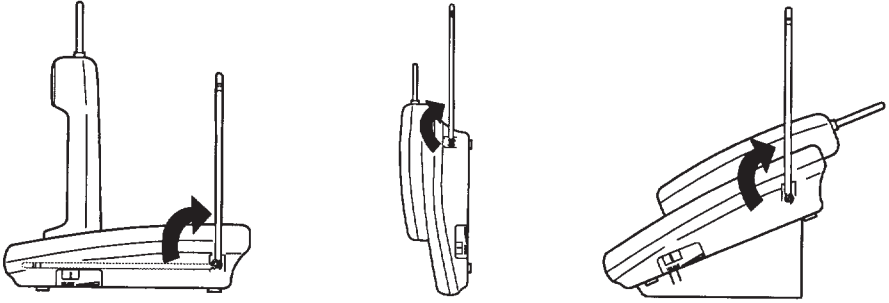

Installing the Handset Battery Pack

1. Press in on the Battery Cover Release and slide the battery compartment cover down.

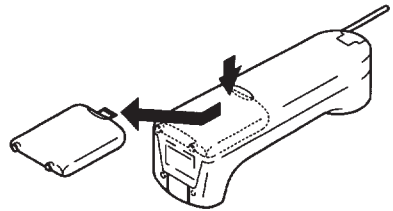

2. Align the plastic connector of the Nickel-Cadmium battery pack with its socket and plug it in.

* *The black lead will be on the left when the plug is properly aligned.*

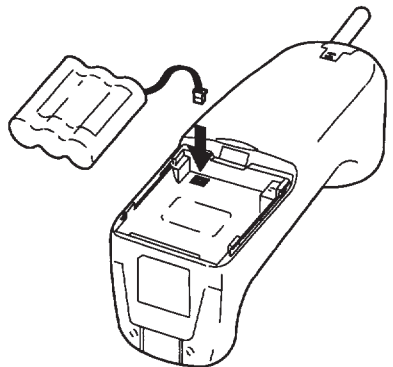

3. Place the battery pack inside the battery compartment, and slide the battery cover back on.

* *The built-in Memory Backup feature allows up to 3 minutes to disconnect the old battery pack and install a new one without losing any numbers stored in memory.*

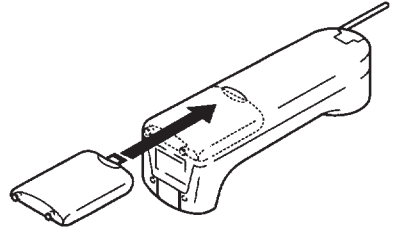

Installing the Beltclip

1. Remove the slot cover.

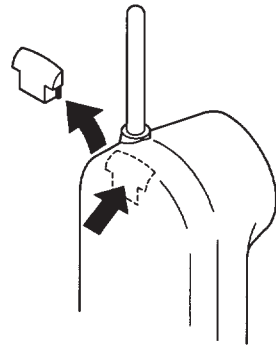

2. Put the beltclip in the slot and press down until it clicks.

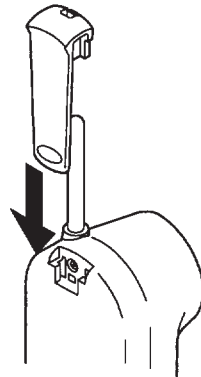

Removing the Beltclip

1. Pull back on the release tab and pull up.

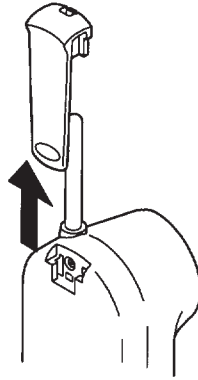

2. Replace the slot cover.

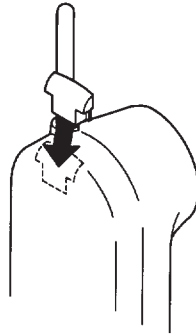

Charging the Battery Pack

Initial Battery Charging

* *The rechargeable Nickel-Cadmium battery pack must be fully charged before using your phone for the first time. We recommend that the battery pack charge for approximately 15-20 hours, without interruption, before plugging the phone line into your new phone.*

1. Either place the Handset upright on the Base Unit

— OR —

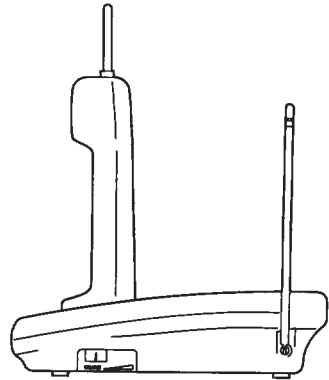

Place the Handset on the cradle when the phone is on the desktop stand.

— OR —

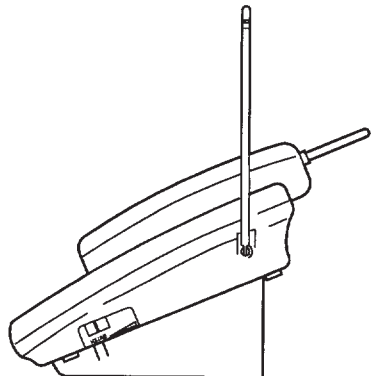

Hang the Handset on the cradle when the phone is mounted on a wall.

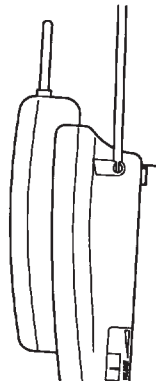

2. Make sure the **status** LED on the Base Unit lights. If the LED doesn't light, check to see that the AC adapter is plugged in, and that the Handset is making good contact with the Base Unit charging contacts.

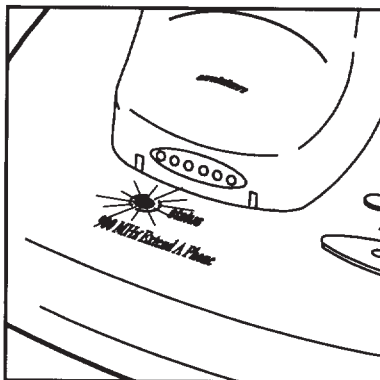

Continuous Battery Charging

For the best battery performance, return the Handset to the Base Unit at the end of the day.

Low Battery Indicator

When the Battery Pack in the Handset is very low and needs to be charged, the **talk/batt low** LED on the Handset flashes.

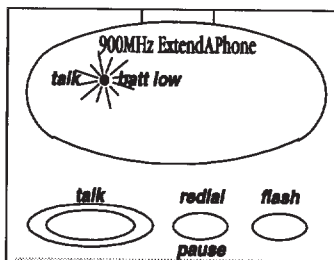

If the **talk/batt low** LED begins to flash, the phone is programmed to eliminate its functions to save power. The table below describes what to do to return your phone to normal operation.

During a Call	In Standby Mode
—	None of the buttons will operate.
The Handset beeps and the talk/batt low LED flashes once every 3 seconds.	The talk/batt low LED flashes once every 3 seconds.
Complete your call as quickly as possible.	You will not be able to make a call.
Return the Handset to the Base Unit for charging.	Return the Handset to the Base Unit for charging.

* *Allow 15 to 20 hours without any interruption for the Handset to fully recharge.*

Cleaning the Battery Contacts

To maintain a good charge, it is important to clean all charging contacts on the Handset and Base Unit about once a month. Use a pencil eraser or other contact cleaner. Do not use any liquids or solvents.

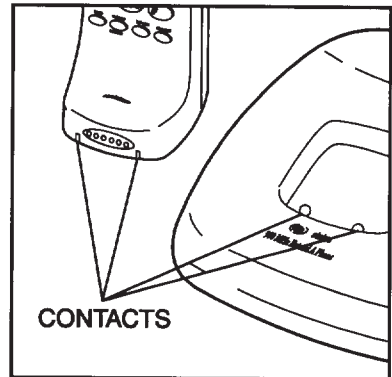

* Please refer to the foldout in front of your operating guide for key positions.

Setting the Pulse-Tone Switch

Be sure the **PULSE-TONE** switch is in the **TONE** position.

* Most phone systems are Tone dialing. Check with your local phone company if you are not sure whether your system is Tone or Pulse dialing.

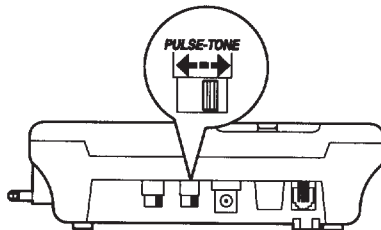

Adjusting Ringer Controls

To adjust the ringer volume of your Base Unit, set the **RING VOL** switch to the desired position.

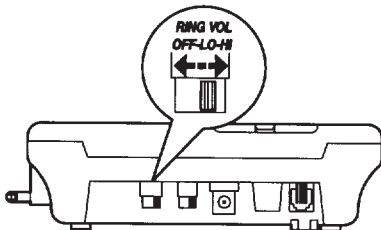

To adjust the Speaker volume of your Base Unit, adjust the **VOLUME** slide switch until you hear the desired volume.

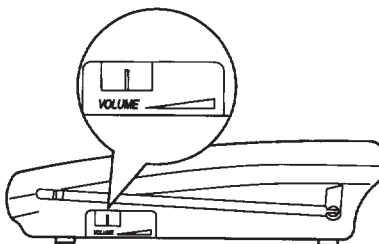

To adjust the ringer tone and volume of your Handset, press **volume/ringer** repeatedly until you hear the desired ringer tone and volume.

To adjust the receiver volume, press **volume/ringer** while you are on a call.

Automatic Digital Code Security

To avoid unauthorized calls on your phone, a Digital Code feature was added to the **EX 945** phone. This Digital Code is shared only between the Handset and Base Unit. The Code is set automatically when you first use the phone.

*** Please refer to the foldout in front of your operating guide for key positions.**

To change the Digital Code, be sure the Handset is on the Base, then:

1. Remove the Handset from the Base Unit and Press the **page/find** button on the Base Unit.
2. Place the Handset back on the Base Unit while it's still beeping.

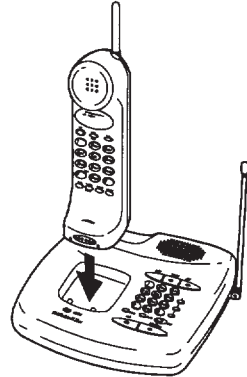

4. When the beeping stops, briefly remove the Handset again, and then return it to the Base Unit.
5. The **status** LED on the Base Unit will blink to indicate that the Digital Security Code is set to one of the more than 65,000 codes.



*** If the Base Unit loses power while the Handset is off the Base, the Digital Code may be erased. When this happens, the Handset will not function.**

To reestablish communication between the Handset and Base Unit:

1. Restore power to the Base Unit.
2. Place the Handset back on the Base Unit.
3. The **status** LED on the Base Unit will blink to indicate that the Digital Security Code is set.

Programming Your EX 945

- * Refer to the foldout located in the front of this Operating Guide for key positions.

Storing Memory Dial Numbers

Numbers can be stored for use by the Base Unit and the Handset separately. There are 10 memory locations for the Base Unit, and 10 memory locations for the Handset. There are also three one touch dialing memory locations for the Base Unit.

- * Numbers stored with the Handset cannot be accessed by the Base Unit.
Numbers stored with the Base Unit cannot be accessed by the Handset.
Numbers stored with one touch dialing cannot be accessed by the Handset.

Entering Base Unit Memory Numbers

For example, to store the number 555-1212 in the Base Unit memory:

1. Press **memo** on the Base Unit.
The **speaker** LED blinks and you hear a beep.

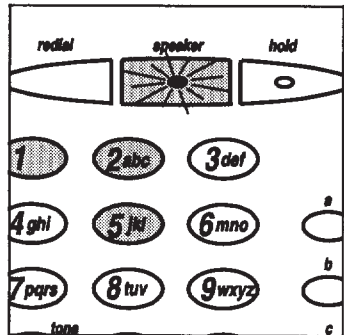

2. Enter the number **5551212** on the Base Unit keypad.
- * You may enter a delay between numbers (for accessing a switchboard, or long distance service) by pressing the **pause** button on the Base Unit at the point in the number sequence you wish to pause. The **pause** button counts as one digit. Pressing **pause** more than once will increase the length of the pause between numbers.
3. Press **memo** and a number (**0-9**) from the Base Unit keypad for the memory location.
- * After pressing **memo** the second time, you have 20 seconds to enter the number you wish to store. Otherwise, an error tone will sound and the unit returns to Standby.

- You will hear a confirmation beep and the **speaker** LED goes out.
Write the stored number and its memory location number on one of the enclosed stickers.

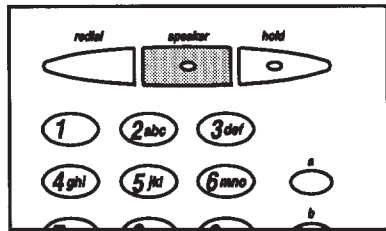

Entering Base Unit One Touch Memory Numbers

For example, to store the number 555-1212 in the Base Unit one touch dialing memory:

- Press **memo** on the Base Unit.
The **speaker** LED blinks and you hear a beep.

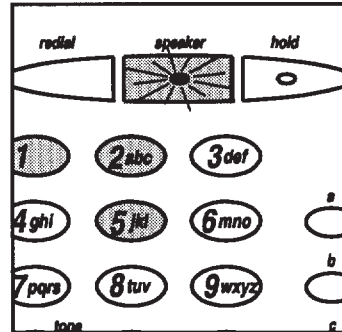

- Enter the number **5551212** on the Base Unit keypad.
- * You may enter a delay between numbers (for accessing a switchboard, or long distance service) by pressing the **pause** button on the Base Unit at the point in the number sequence you wish to pause. The **pause** button counts as one digit. Pressing **pause** more than once will increase the length of the pause between numbers.*
- Press **memo** and a one touch location, (**a**, **b**, or **c**) from the Base Unit keypad for the memory location.
- * After pressing **memo** the second time, you have 20 seconds to enter the number you wish to store. Otherwise, an error tone will sound and the unit returns to Standby.*

- You will hear a confirmation beep and the speaker LED goes out.
Write the stored number and its one touch location on one of the enclosed stickers.

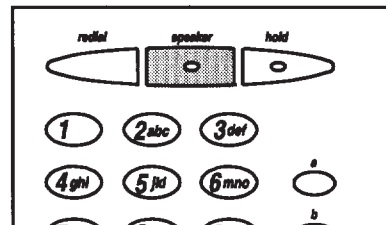

Entering Handset Memory Numbers

For example, to store the number 555-1212 in the Handset memory:

1. Pick up the Handset and press **mem**.
You will hear a beep and the **talk/batt low** LED flashes.

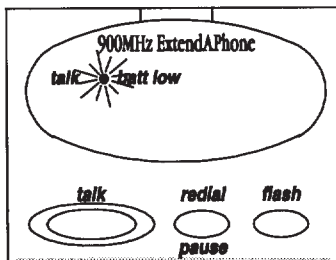

2. Enter the number **5551212** on the Handset keypad.
*** You may enter a delay between numbers (for accessing a switchboard, or long distance service) by pressing the redial/pause button on the Handset at the point in the number sequence you wish to pause. The redial/pause button counts as one digit. Pressing redial/pause more than once will increase the length of the pause between numbers.**
3. Press **mem**. You will hear another confirmation beep.
4. Enter a number (**0-9**) from the Handset keypad for the memory location.
*** After pressing mem the second time, you have 20 seconds to enter the number you wish to store. Otherwise, an error tone will sound and the unit returns to Standby.**
5. You will hear a confirmation beep and the talk/batt low LED goes out.
Write the stored number and its memory location number on one of the enclosed stickers.

Storing Mixed Pulse/Tone Numbers

If your Base Unit is set up for Pulse Dialing, you can store a mixed mode number to easily access long distance services or other services requiring Tone inputs.

Entering Base Unit Pulse/Tone Memory Numbers

For example, to enter 555-1212 as a pulse number followed by 12 as a tone number from the Base Unit:

1. Press **memo** on the Base Unit.
The **speaker** LED blinks and you hear a beep.
2. Enter **5551212** on the Base Unit keypad.
3. Press the **tone** button on the Base Unit.

4. Enter **12** on the Base Unit keypad. If desired, press **pause** on the Base Unit to enter delays between numbers.
5. Press **memo** and a number (**0-9**) from the Base Unit keypad for the memory location.

* *After pressing **memo** the second time, you have 20 seconds to enter the number you wish to store. Otherwise, an error tone will sound and the unit returns to Standby.*

6. You will hear a confirmation beep and the **speaker** LED goes out.
Write the stored number and its memory location number on one of the enclosed stickers.

Entering Handset Pulse/Tone Memory Numbers

For example, to enter 555-1212 as a pulse number followed by 12 as a tone number from the Handset:

1. Pick up the Handset and press **mem**. You will hear a beep and the **talk/batt low** LED flashes.
2. Enter **5551212** on the Handset keypad.
3. Press the **tone** button on the Handset.

* *The **tone** button counts as one digit and enters a four second delay.*

4. Enter **12** on the Handset. If desired, press **redial/pause** on the Handset to enter delays between numbers.
5. Press **mem**. You will hear another confirmation beep.

* *After pressing **mem** the second time, you have 20 seconds to enter the number you wish to store. Otherwise, an error tone will sound and the unit returns to Standby.*

6. Enter a number (**0-9**) from the Handset keypad for the memory location.
7. You will hear a confirmation beep and the **talk/batt low** LED goes out.
Write the stored number and its memory location number on one of the enclosed stickers.

Erasing a Stored Number

You can erase stored numbers from the Base Unit and the Handset memory.

Erasing Base Unit Memory Numbers

1. Press **memo** twice on the Base Unit.

2. Enter the memory location number (**0-9**) you want to clear. You will hear a long beep confirming the number is erased.

Erasing Handset Memory Numbers

1. On the Handset press **mem** twice.
2. Enter the memory location number (0-9) you want to clear. You will hear a long beep confirming the number is erased.

Using Your EX 945

* Refer to the foldout located in the front of this Operating Guide for key positions.

Answering a Call from the Base Unit

1. The Base Unit rings, and the green **status** LED on the Base Unit flashes.
2. Press the **speaker** button.
3. Speak into the Base Unit microphone.
4. When you finish the call, press **speaker** to hang up.

Answering a Call from the Handset

1. The Handset rings and the **talk/batt low** LED flashes.

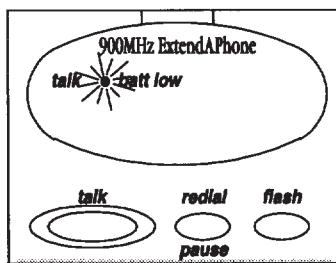

2. If the Handset is not in the Base Unit, press **talk** to answer the call.

—OR—

If the Handset is in the Base Unit, the *AutoTalk* feature allows you to answer the call by simply picking up the Handset and beginning your conversation.

3. When you finish the call, place the Handset back on the Base Unit.

AutoStandby automatically hangs up the phone. There is no need to press **talk** to hang up.

—OR—

If the Handset is away from the Base Unit, press **talk** to hang up the phone.

Making a Call from the Base Unit

1. Press **speaker**.
2. When the **speaker** LED is on and you hear a dial tone, dial the number you are calling by pressing the numbers on the keypad or using one of the memory features. See "Dialing Stored Numbers" on page 36.

3. When you finish the call, press **speaker** to hang up.

Making a Call from the Handset

1. Pick up the Handset.
2. Press **talk**.
3. The talk LED goes on.
4. When you hear a dial tone, dial the number you are calling by pressing the numbers on the keypad, or use one of the memory features. See “Dialing Stored Numbers” below.
5. When you finish the call, place the Handset back on the Base Unit.

AutoStandby automatically hangs up the phone.

—OR—

When the Handset is away from the Base Unit, press **talk** to hang up the phone.

Dialing Stored Numbers

There are 10 memory locations available for the Base Unit and 10 memory locations available for the Handset. There are also three one touch memory locations available on the Base Unit. See “Entering Base Unit Memory Numbers” on page 30, “Entering Handset Memory Numbers” on page 32, or “Entering Base Unit One Touch Memory Numbers” on page 31.

Dialing Base Unit Memory Numbers

For example, to dial memory number 3 from the Base Unit:

1. Press **speaker** on the Base Unit.
2. Press **memo** on the Base Unit and number **3** on the Base Unit keypad.

** If you select a memory location that does not have a stored number, the Base Unit will beep rapidly and the phone will not dial.*

Dialing One Touch Base Unit Memory Numbers

For example, to dial one touch memory location a from the Base Unit:

1. Press **speaker** on the Base Unit.
2. Press **a** on the Base Unit keypad.

** If you select a memory location that does not have a stored number, the Base Unit will beep rapidly and the phone will not dial.*

Dialing Handset Memory Numbers

For example, to dial memory number **4** from the Handset:

1. Pick up the Handset.
2. Press **talk**. The **talk/batt low** LED goes on.
3. Press **mem**.
4. Press number **4** on the Handset.

✱ *If you select a memory location that does not have a stored number, the Handset will beep rapidly and the phone will not dial.*

Chain Dialing

On certain occasions, after dialing a number, you may be requested by the party or service you are calling to enter a special access code, such as when performing a banking transaction. To store this number, refer to "Storing Memory Dial Numbers" on page 30.

For example, if your bank's telephone number is stored in Base Unit memory location 3, and your account number is stored in Base Unit memory location 4:

1. Press **speaker** on the Base Unit.
2. Press **memo** on the Base Unit and number **3** on the Base Unit keypad.
3. At the appropriate time, press **memo** and number **4** on the Base Unit keypad.
4. Your Base Unit dials the number and you may proceed with your transaction.

Placing a Call On Hold

* *Use either the keypad on the Handset or the keypad on the Base Unit. Do not use both keypads at the same time.*

For example, to place a call on hold:

1. While you are on a call, press **hold**. The **hold** LED lights.

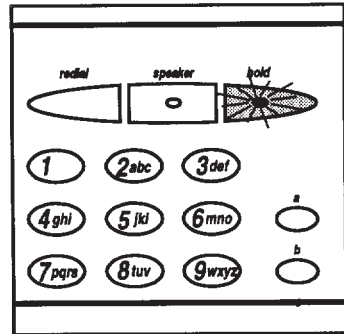

2. To pick up the call holding, press **talk** on the Handset or **hold** on the Base Unit.

Using the EX 945 with Call Waiting

* *You must subscribe to Call Waiting from your local telephone company for this feature to work.*

Press the **flash** button while operating from either the Handset or Base Unit. This feature sends a timed “hook-flash” on the telephone line for accessing services such as Call Waiting, etc.

Last Number Redial

The **EX 945** has two independent Last Number Redial memories; one in the Handset, the other in the Base Unit.

1. To call the last number dialed from the Handset, press **redial**.
- * *If any other key is pressed before **redial/pause**, the Handset will not redial the last number.*
2. To call the last number dialed from the Base Unit, press **redial**.
- * *If any other key is pressed before **redial**, the Base Unit will not redial the last number.*

Using your **EX 945** Intercom

The Base Unit **RING VOL** switch must be set to either “**LO**” or “**HI**.”
(Note: When a call is on hold at the Handset and the Base Unit is paged, the Base Unit will ring even when the **RING VOL** switch is set to “**OFF**.”)

Paging from the Base Unit to the Handset

1. Press **page/int'com**. (If no answer, press **page/int'com** again to disconnect.)
2. Press **talk** or **int'com** on the Handset to answer the page. Speak into the mouthpiece.
3. To turn off the Intercom, press **speaker** on the Base Unit.

— OR —

Press **talk** on the Handset.

Paging from the Handset to the Base Unit

1. Press **int'com** on the Handset. (If no answer, press **int'com** to disconnect.)
2. At the Base Unit, press **speaker** or **page/int'com** to answer the page. Speak into the microphone.
3. To turn off the Intercom, press **speaker** at the Base Unit.

— OR —

Press **int'com** on the Handset.

Paging the Base Unit While a Call is Holding

1. Press **int'com** on the Handset. If no answer, press **talk** or **int'com** to disconnect and return to the call on hold.
2. At the Base Unit, press **page/int'com** to answer the page. Speak into the microphone.
3. To turn off the Intercom, press **speaker** at the Base Unit.

— OR —

Press **talk** on the Handset to transfer the call to the Base Unit or press **talk** twice to initiate a three way conversation.

Paging the Handset While a Call is Holding

1. Press **page/int'com** on the Base Unit. The call is placed on hold and the Handset is paged.
2. At the Handset, press **talk** or **int'com** to answer the page. Speak into the microphone.
3. To turn off the Intercom, press **talk** at the Handset.

— OR —

Press **speaker** on the Base Unit to transfer the call to the Handset or press **speaker** twice to initiate a three way conversation.

Mute Function

* *You can only mute a call while using the Base Unit., Press mute to disable the Base Unit microphone.*

1. Press **mute**.
2. The **mute** LED lights.

* *You will be able to hear the caller, but they will not hear you.*

Troubleshooting

If your **EX 945** Cordless Telephone is not performing to your expectations, please try these simple steps. If you are still unable to resolve the problems, contact Uniden Customer Service at: (800) 297-1023, 8 AM to 5 PM Central, Monday through Friday.

Problem	Suggestion
<p>Status light won't come on when Handset is placed in Base Unit.</p>	<p>Make sure the AC Adapter is plugged into the Base Unit and wall outlet.</p> <p>Make sure Handset is properly seated in Base Unit.</p> <p>Make sure the Nickel-Cadmium Battery Pack is properly placed inside the Handset.</p> <p>Make sure that the charging contacts on the Handset and Base Unit are clean.</p>
<p>Audio sounds weak and/or scratchy.</p>	<p>Make sure that the Base Unit antenna is fully vertical.</p> <p>Move the Handset and/or Base Unit to different locations and try again.</p>
<p>Can't make or receive calls.</p>	<p>Check both ends of the Base Unit telephone line cord.</p> <p>Make sure the AC Adapter is plugged into the Base Unit and wall outlet.</p>

<p>Handset doesn't ring or receive a page.</p>	<p>Disconnect the AC Adapter for a few minutes, and then reconnect it.</p> <p>Nickel-Cadmium Battery Pack may be weak. Charge the battery on the Base Unit for 15 - 20 hours.</p> <p>The Handset may be too far away from the Base Unit.</p> <p>Place the Base Unit away from noise sources.</p> <p>Make sure the Base Unit antenna is fully vertical.</p>
<p>Base Unit doesn't ring or receive a page.</p>	<p>The Digital Security Code may be erased. Set the Digital Code. (See page 28 for instructions.)</p> <p>Set the Base Unit RING VOL switch to "LO" or "HI".</p>

Specifications

General: The *EX 945* complies with FCC parts 15 & 68.

Frequency Control: PLL
Modulation: FM
Operating Temperature: -10°C to 50°C

Base Unit:

Transmit Frequency: 925.000 to 927.900 MHz
Power Requirements: 120V 60Hz
Size: 8 3/8 in. (W) x 5 17/32 in. (D)
x 1 7/8 in (H)
Weight: Aprox. 18.9 oz.

Handset:

Transmit Frequency: 902.100 to 905.000 MHz
Power Requirements: 600 mAh, 3.6VDC
Size: (w/ antenna) 2 3/16 in. (W) x 2 11/16 in. (D)
x 12 3/32 in. (H)
Weight: Approx. 10 oz. (including battery)
Battery: Rechargeable Nickel Cadmium
Capacity: 600 MAH 3.6 V
Talk Mode: 8 Hours
Standby Mode: 14 Days

Specifications shown are typical and subject to change without notice.

One-Year Limited Warranty

Important: Evidence of original purchase is required for warranty service.

WARRANTOR: UNIDEN AMERICA CORPORATION (“Uniden”)

ELEMENTS OF WARRANTY: Uniden warrants, for one year, to the original retail owner, this Uniden Product to be free from defects in materials and craftsmanship with only the limitations or exclusions set out below.

WARRANTY DURATION: This warranty to the original user shall terminate and be of no further effect 12 months after the date of original retail sale. The warranty is invalid if the Product is (A) damaged or not maintained as reasonable or necessary, (B) modified, altered, or used as part of any conversion kits, subassemblies, or any configurations not sold by Uniden, (C) improperly installed, (D) serviced or repaired by someone other than an authorized Uniden service center for a defect or malfunction covered by this warranty, (E) used in any conjunction with equipment or parts or as part of any system not manufactured by Uniden, or (F) installed or programmed by anyone other than as detailed by the Operating Guide for this product.

STATEMENT OF REMEDY: In the event that the product does not conform to this warranty at any time while this warranty is in effect, warrantor will repair the defect and return it to you without charge for parts, service, or any other cost (except shipping and handling) incurred by warrantor or its representatives in connection with the performance of this warranty. **THE LIMITED WARRANTY SET FORTH ABOVE IS THE SOLE AND ENTIRE WARRANTY PERTAINING TO THE PRODUCT AND IS IN LIEU OF AND EXCLUDES ALL OTHER WARRANTIES OF ANY NATURE WHATSOEVER, WHETHER EXPRESS, IMPLIED OR ARISING BY OPERATION OF LAW, INCLUDING, BUT NOT LIMITED TO ANY IMPLIED WARRANTIES OF MERCHANTABILITY OR FITNESS FOR A PARTICULAR PURPOSE. THIS WARRANTY DOES NOT COVER OR PROVIDE FOR THE REIMBURSEMENT OR PAYMENT OF INCIDENTAL OR CONSEQUENTIAL DAMAGES.** Some states do not allow this exclusion or limitation of incidental or consequential damages so the above limitation or exclusion may not apply to you.

LEGAL REMEDIES: This warranty gives you specific legal rights, and you may also have other rights which vary from state to state. This warranty is void outside the United States of America.

PROCEDURE FOR OBTAINING PERFORMANCE OF WARRANTY: If, after following the instructions in this Operating Guide you are certain that the Product is defective, pack the Product carefully (preferably in its original packaging). Include evidence of original purchase and a note describing the defect that has caused you to return it. The Product should be shipped freight prepaid, by traceable means, or delivered to warrantor at:

Uniden America Corporation
Parts and Service Division
4700 Amon Carter Blvd.
Fort Worth, TX 76155
(800) 297-1023, 8 a.m. to 5 p.m. Central,
Monday through Friday

Covered under one or more of the following U.S. patents:

4,511,761 4,523,058 4,595,795 4,797,916
5,426,690

uniden®

©1996 All Rights Reserved
Printed in Hong Kong