



## **Polycom IP 500/501 User Guide**

## Table of Contents

<b>Table of Contents</b> .....	<b>2</b>
<b>Introduction</b> .....	<b>3</b>
The Polycom IP500/501 IP Phone .....	3
<b>Web Portal</b> .....	<b>3</b>
<b>Telephony Toolbar</b> .....	<b>3</b>
<b>Document Format</b> .....	<b>4</b>
<b>Feature Functionality</b> .....	<b>4</b>
<b>Feature Functionality</b> .....	<b>5</b>
Account Codes - Verified .....	5
Account Codes - Unverified.....	5
Ad-Hoc Conference Calling.....	5
Call Forward Always.....	6
Call Forward Busy.....	7
Call Forward No Answer.....	7
Call Park .....	7
Call Park Retrieve.....	7
Call Pickup .....	8
Directed Call Pickup.....	8
Call Return .....	8
Call Transfer – Blind .....	8
Call Transfer – Consult .....	8
Call Transfer – To Voicemail.....	9
Call Waiting.....	9
Cancel Call Waiting Per Call.....	9
Caller ID Blocking Per Call .....	10
Caller ID Delivery Per Call.....	10
Dialing.....	10
Do Not Disturb.....	10
Hold .....	11
Last Number Redial.....	12
Push-to-Talk .....	12
Speed Dial 100.....	12
Speed Dial 8.....	13
Voicemail.....	13

## Introduction

The purpose of this document is to inform Zayo Managed Services users on how use the Polycom IP500/501 Phone with their Hosted PBX Service. Each feature available with the Professional Seat will be described along with instructions on how to use the feature. Some users may not have all of the functionality described in this document. Seat type purchased determines which features are available.

### **The Polycom IP500/501 IP Phone**

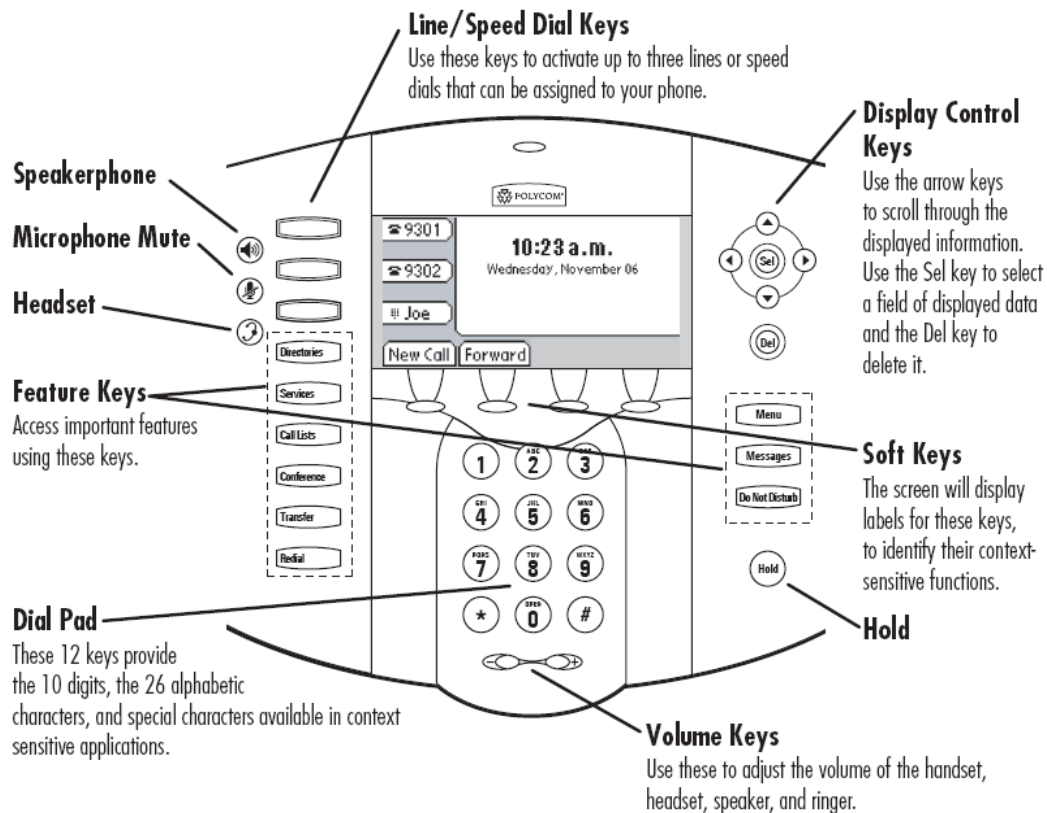

## Web Portal

The Zayo Managed Services Web Portal is a robust online tool used to configure calling features such as do-not-disturb and selective call forward. While most features can be activated using the phone, you may want to explore the Web Portal to fully enjoy all of the powerful call management tools available. Please see your company's Administrator for access to the Web Portal.

## Telephony Toolbar

The Telephony Toolbar is a software application for Microsoft Outlook, Microsoft Internet Explorer, or Mozilla Firefox and can be used to configure calling features such as do-not-disturb and call forward, and can also be used for a wide variety of click to call features. The Telephony Toolbar complements the Web Portal and allows users easy access to often used calling features. Please see your company's Administrator for more information on the Telephony Toolbar.

## Document Format

Below is an example of how each feature will be presented and examined in this document.

FEATURE NAME  
AND  
DESCRIPTION

### *Ad-Hoc Conference Calling*

Allows a user to make a three-way conference call. Users also have the ability to execute three-way calling using the Web Portal Call Manager.

STEP BY STEP  
INSTRUCTIONS  
FOR USING THE  
FEATURE

#### Using the Feature

1. During an active call, press the **MORE** soft key, then press the **CONF** soft key. This will place the current caller on hold.
2. Dial the **NUMBER** of the party you wish to add to the call.
3. When the party answers, press the **MORE** soft key, then press the **CONF** soft key to add the caller to the existing call.

STEP BY STEP  
INSTRUCTIONS  
FOR EXTENDED  
FEATURE  
FUNCTIONALITY

#### Extended Functionality

1. To split the existing conference call, press the **SPLIT** soft key. This places both calls on hold on separate lines.
2. Press the **LINE** button of the call you would like to disconnect, and then press the **ENDCALL** soft key.
3. Press the **LINE** button of the call you would like to continue.

## Feature Functionality

### **Account Codes - Verified**

Requires a user to enter a unique number that identifies to which account an outbound call should be assigned.

#### **Using the Feature**

1. **GO OFF HOOK.**
2. Dial the **NUMBER** of the party you wish to call.
3. An **IVR** will instruct you to enter your Account Code.
4. Once your code is entered the call will connect.

#### **Extended Functionality**

A user can turn a particular account code on for a sustained amount of time by using a star code.

##### Sustained Account Code Activation

1. **GO OFF HOOK.**
2. Press **\*47**.
3. An **IVR** will instruct you to enter your Account Code.

##### Sustained Account Code Deactivation

1. **GO OFF HOOK.**
2. Press **\*37**.

### **Account Codes - Unverified**

Allows a user to enter a unique number to identify to which account an outbound call should be assigned.

#### **Using the Feature**

1. **GO OFF HOOK.**
2. Press **\*02**.
3. An **IVR** will instruct you to enter your Account Code. You will hear a stutter dial tone then a normal dial tone.
4. Dial the **NUMBER** of the party you wish to call.

### **Ad-Hoc Conference Calling**

Allow a user to make a three-way conference call.

#### **Using the Feature**

1. During an active call, press the **CONFRNC** soft key. This will place the current caller on hold and provide dial tone.
2. Dial the **NUMBER** of the party you wish to add to the call and press the **SEND** soft key.
3. When the party answers, press the **CONFRNC** soft key to add the caller to the existing call.

## Extended Functionality

A user may use the **CONFERENCE** Feature Key instead of the soft key.

### *Splitting a Conference Call*

1. To split the existing conference call, press the **SPLIT** soft key. This places both calls on hold on separate lines.
2. Using the **DISPLAY CONTROL** keys, select the call you would like to disconnect, press the **RESUME** soft key, then press the **ENDCALL** soft key.
3. Press the **RESUME** button once the first call is disconnected to speak with the caller that is still connected.

## Call Forward Always

Allow a user to redirect all incoming calls to another phone number. Users have the option to activate and deactivate the service by using the soft keys, or by dialing a feature code.

**NOTE:** The user must use the same method to turn the function off that they used to turn the function on. Otherwise, the system will not recognize the 'off' command.

## Using the Feature

### *Activate: Using the Soft Keys<sup>†</sup>*

1. Press the **FORWARD** soft key.
2. Using the **DISPLAY CONTROL** keys, select the **LINE** that you want forwarded.
3. Press the **SELECT** soft key.
4. Enter the forwarding **NUMBER** with the **KEYPAD**.
5. Press the **ENABLE** soft key.

<sup>†</sup>This soft key is not available if the phone number is shared on another phone.

### *Deactivate: Using the Soft Keys*

1. Press the **FORWARD** soft key.
2. Using the **DISPLAY CONTROL** keys, select the **LINE** that you want forwarded.
3. Press the **SELECT** soft key.
4. Press the **DISABLE** soft key.

### *Activate: Using the Feature Code*

1. **GO OFF HOOK**
2. Press **\*72**
3. Follow the **IVR** instructions.

### *Deactivate: Using the Feature Code*

1. **GO OFF HOOK**
2. Press **\*73**

## Call Forward Busy

Enable a user to redirect calls to another destination when the user's line is busy. Normally, a call would be directed to a user's voicemail.

### Using the Feature

#### Activate:

1. **GO OFF HOOK**
2. Press **\*90**
3. Follow the **IVR** instructions.

#### Deactivate

1. **GO OFF HOOK**
2. Press **\*91**

## Call Forward No Answer

Enable a user to redirect calls to another destination when an incoming call is not answered within a specified number of rings. Normally, a call would be directed to a user's voicemail.

### Using the Feature

#### Activate: Using the Feature Code

1. **GO OFF HOOK**
2. Press **\*92**
3. Follow the **IVR** instructions.

#### Deactivate: Using the Feature Code

1. **GO OFF HOOK**
2. Press **\*93**

## Call Park

Enables a user to place a call on hold and allow a user to pick up the call at another phone.

### Using the Feature

1. During an active call, press the **HOLD** soft key. This will place the caller on hold.
2. Press the **NEWCALL** soft key.
3. Press **\*68**.
4. Follow the **IVR** instructions.

## Call Park Retrieve

This feature enables a user to pickup a call that has been placed on hold using the Call Park feature.

### Using the Feature

1. **GO OFF HOOK**

2. Press **\*88**.
3. Follow the **IVR** instructions.

## **Call Pickup**

This feature enables a user to pickup a call that is coming in on another user's line. The other user's line must be in the same 'pickup group' with the user activating the feature. Pickup groups are pre-configured by the System Administrator.

### **Using the Feature**

1. **GO OFF HOOK**
2. Press **\*98**.

## **Directed Call Pickup**

This feature enables a user to pickup a call that is coming in on another user's line without being specifically assigned to a common group. The other user's line must also have the Directed Call Pickup feature assigned to it.

### **Using the Feature**

1. **GO OFF HOOK**
2. Press **\*97** plus the extension that you wish to pickup.

## **Call Return**

Allows a user to call back the last number that called their line, regardless of whether or not the phone was answered.

### **Using the Feature**

1. **GO OFF HOOK**
2. Press **\*69**.

## **Call Transfer – Blind**

Allow incoming calls to be transferred to another line without consultation with the receiving party.

### **Using the Feature**

1. During the call, Press the **TRANSFER** soft key. This will place the caller on hold and provide dial tone.
2. Press the **BLIND** soft key.
3. Enter the transfer **NUMBER** with the **KEYPAD**.
4. Press the **SEND** soft key.
5. **HANG UP**.

### **Extended Functionality**

A user may use the **TRANSFER** Feature Key instead of the soft key.

## **Call Transfer – Consult**

Allow incoming calls to be transferred to another line with consultation with the receiving party.



## Using the Feature

1. During the call, press the **TRANSFER** soft key. This will place the caller on hold and provide dial tone.
2. Enter the transfer **NUMBER** with the **KEYPAD**.
3. Press the **SEND** soft key.
4. When the second party picks up you may consult with them.
5. Press the **TRANSFER** soft key to transfer the call.
6. Press the **CANCEL** soft key to return to the first caller without transferring the call.

## Extended Functionality

A user may use the **TRANSFER** Feature Key instead of the soft key.

## Call Transfer – To Voicemail

Allow incoming calls to be transferred to any user's voicemail.

### Using the Feature

1. During the call, press the **HOLD** soft key or button. This will place the caller on hold.
2. Press the **NEW CALL** soft key to get a dial tone.
3. Dial **\*55**
4. Follow the **IVR** instructions. Press the **#** key to send the caller to your own voicemail box. To send the caller to another voicemail box, enter the desired extension followed by the **#** key.

## Call Waiting

This feature enables a user to answer a call when engaged in another call. When a second call is received while a user is engaged in a call, the user is informed via a call waiting tone.

### Using the Feature

#### *Retrieving the Second Call*

1. When a call rings in, use the **DISPLAY CONTROL** keys to select the second **LINE**.
2. Press the **ANSWER** soft key.

#### *Getting Back to the First Call*

3. Use the **DISPLAY CONTROL** keys to select the **LINE** which is on hold.
4. Press the **RESUME** soft key. This places the other call on hold.

### Extended Functionality

#### *Sending the Second Call to Voicemail*

5. When a call rings in, use the **DISPLAY CONTROL** keys to select the second **LINE**.
6. Press the **REJECT** soft key.

## Cancel Call Waiting Per Call

Allow users to turn off call waiting on a call-by-call basis.

### Using the Feature

1. **GO OFF HOOK.**
2. Press **\*70**. You will hear a stutter dial tone then a normal dial tone.
3. Dial the **NUMBER** of the party you wish to call.

### Caller ID Blocking Per Call

Allow users to block their caller ID on a call-by-call basis.

#### Using the Feature

1. **GO OFF HOOK.**
2. Press **\*67**. You will hear a stutter dial tone then a normal dial tone.
3. Dial the **NUMBER** of the party you wish to call.

### Caller ID Delivery Per Call

Allow users to deliver their caller ID on a call-by-call basis when they have turned on the Caller ID Blocking feature within the Web Portal.

#### Using the Feature

4. **GO OFF HOOK.**
5. Press **\*65**. You will hear a stutter dial tone then a normal dial tone.
6. Dial the **NUMBER** of the party you wish to call.

### Dialing

Allow a user to make a call.

#### Using the Feature

##### Placing a Call

1. Pick up **HANDSET**, press the **NEWCALL** soft key, or press the **SPEAKERPHONE KEY**.
2. Enter the number you wish to call.
3. Press the **SEND** soft key, or wait to connect.

#### Extended Functionality

##### Placing a Call

1. Dial the **NUMBER** you wish to call using the **KEYPAD**.
2. Press the **DIAL** soft key.

### Do Not Disturb

Allow users to set their station as unavailable so that incoming calls are given a busy treatment. Depending on how the user has set up their busy treatment, the callers will be directed to voicemail or forwarded to another line.

**NOTE:** The user must use the same method to turn the function off that they used to turn the function on. Otherwise, the system will not recognize the 'off' command.

## Using the Feature

### Activate: Using the Phone's Keys<sup>†</sup>

1. Press the **DO NOT DISTURB** button.
2. Using the **DISPLAY CONTROL** keys, select the individual **LINE** that you want to place in Do Not Disturb mode and then press the **SELECT** soft key, or press the **SET ALL** soft key to select all lines.
3. Press the **ENABLE** soft key.

<sup>†</sup>If the phone number is shared on another phone, enabling Do Not Disturb on the phone will simply turn on silent ring and does not make it busy. Calls may still be answered on any phone sharing the phone number.

Depending on how the phone was provisioned, pressing the Do Not Disturb button will either automatically place all line appearances into Do Not Disturb, or you may be prompted for which lines to place on Do Not Disturb.

### Deactivate: Using the Phone's Keys

1. Press the **DO NOT DISTURB** button.
2. Using the **DISPLAY CONTROL** keys, select the **LINE** to remove from Do Not Disturb mode and press the **SELECT** soft key, or press the **CLEAR ALL** soft key to remove from all lines.
3. Press the **DISABLE** soft key.

### Activate: Using the Feature Code

1. **GO OFF HOOK**
2. Press **\*78**

### Deactivate: Using the Feature Code

1. **GO OFF HOOK**
2. Press **\*79**

## Hold

Allows user to place a call on hold and retrieve it.

## Using the Feature

### Activate: Using the Soft Keys<sup>†</sup>

1. Press the **HOLD** soft key.

### Deactivate: Using the Soft Keys<sup>†</sup>

1. Press the **RESUME** soft key.

<sup>†</sup>If the phone number is shared on another phone, you can put a call on-hold and take the call off-hold at the other phone that is sharing the phone number.

## Extended Functionality

The user can use the **HOLD** button on the phone to toggle a call on and off hold.

## Last Number Redial

Allow the user to redial the last number dialed with a feature code or a button.

### Using the Feature

1. Press the **REDIAL** Feature Key.

### Extended Functionality

1. **GO OFF HOOK**
2. Press **\*66**.

## Push-to-Talk

Provides intercom-like functionality. This feature allows a user to dial another station where the system will request the destination station to automatically answer. For this feature to work (called station automatically answers via the speakerphone), the called station must support an enhanced calling protocol. The calling station must also be in the called party's Push-to-Talk allowed access list.

### Using the Feature

*Activate: Using the Feature Code*

1. Pick up **HANDSET**, press the **NEWCALL** soft key, or press the **SPEAKERPHONE KEY**.
2. Dial **\*50**. You will hear a stuttered dial tone then a normal dial tone.
3. Dial the extension of the phone you want to intercom.

### Extended Functionality

Program a Speed Dial 8 number to quickly place an intercom call.

## Speed Dial 100

Allow a user to use a feature code and 2 digits to complete a call.

### Using the Feature

*Configure*

1. **GO OFF HOOK**.
2. Press **\*75**. You will hear a stuttered dial tone then a normal dial tone.
3. Using the **KEYPAD** Enter the Speed Dial 100 Code **00-99** plus the **NUMBER** you want to associate with it and then press the **#** key.
4. The **IVR** will notify you whether or not the programming was successful.

*Use*

1. **GO OFF HOOK**.
2. Press **#**
3. Press the Speed Dial 100 Codes **00-99**.

## Speed Dial 8

Allow a user to hit only one button to complete a call.

### Using the Feature

#### *Configure*

1. **GO OFF HOOK.**
2. Press **\*74**. You will hear a stuttered dial tone then a normal dial tone.
3. Using the **KEYPAD** Enter the Speed Dial 8 Code **2-9** plus the **NUMBER** you want to associate with it and then press the **#** key.
4. The **IVR** will notify you whether or not the programming was successful.

#### *Use*

1. **GO OFF HOOK**
2. Press the Speed Dial 8 Code **2-9** using the **KEYPAD**.

## Voicemail

Allow a user to hear messages left in their voicemail box.

### Using the Feature

#### *From your desk phone* †

1. Press the **MESSAGES** Feature Key.
2. At the voice prompt, enter your **PASSWORD**.
3. To navigate, follow the **IVR** choices.

† Depending on how your phone is configured, pressing the Messages button will immediately connect you to the voice message portal, or may first display a summary on the phone's screen indicating the number of normal and urgent voicemails waiting.

#### *From Outside the Office:*

1. Dial your phone **NUMBER**.
2. When the voice mail system answers, press the **\*** key.
3. Enter your phone's **EXTENSION**.
4. Enter your **PASSWORD**.
5. To navigate, follow the **IVR** choices.

Menu	<i>Key</i>
Save	#
Delete	7
Replay Message / Skip Envelope	2
Fast Forward	3
Rewind	4
Play Message Envelope	5
Call Back Sender	8
Go to Menu 2	9