



MOTOROLA

intelligence everywhere™



MD760 Series User Guide

Digital 5.8GHz

Expandable Cordless Telephone System

Welcome

Congratulations on your purchase of a Motorola product! Your Motorola handset at a glance:

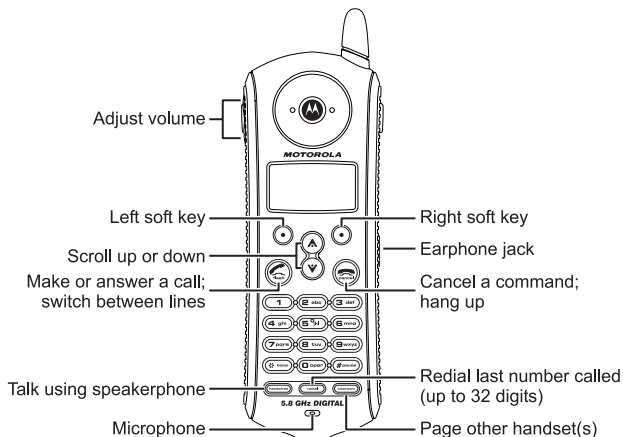

For a copy of a large-print version of this guide, or for product-related questions, please contact:

1-800-353-2729 U.S.A.

1-800-461-4575 Canada

1-888-390-6456 TTY (Text Telephone)

Or visit us online: www.motorola.com/cordless

Product registration is an important step toward enjoying your new Motorola product. Registering helps us facilitate warranty service, and permits us to contact you should your Motorola product require an update or other service. Registration is not required for warranty coverage.

To register your product online, visit:
www.motorola.com/warranty/cordless

Please retain your original dated sales receipt for your records. For warranty service of your Motorola Product, you will need to provide a copy of your dated sales receipt to confirm warranty status.

Copyright © 2004 Motorola, Inc.

All rights reserved. No part of this publication may be reproduced in any form or by any means or used to make any derivative work (such as translation, transformation or adaptation) without written permission from Motorola, Inc.

Motorola reserves the right to revise this publication and to make changes in content from time to time without obligation on the part of Motorola to provide notification of such revision or change. Motorola provides this guide without warranty of any kind, either implied or expressed, including but not limited to, the implied warranties of merchantability and fitness for a particular

purpose. Motorola may make improvements or changes in the product(s) described in this manual at any time.

MOTOROLA, the Stylized M Logo, and PhoneWrap are registered in the U.S. Patent and Trademark Office. All other product or service names are the property of their respective owners.

Table of Contents

Welcome	i
Important Safety Instructions	ix
FCC Information	xiii
Getting Started	1
Battery Safety Instructions	1
Charging the Battery	2
Installing Backup Batteries	4
Using the Handset	5
Using the Handset Display	5
Using the Soft Keys	6
Using the Navigation Key	7
Installation	9
Installing the Phone on a Desk	9
Installing the Phone on the Wall	10
Setting Up	13
Personalizing Your Handset	13
Setting the Ring Volume	13
Setting the Ring Tone	14
Setting Key Beeps On or Off	14
Setting the Charging LED	15
Naming a Handset	16
Storing Area Codes for Caller ID	18
Setting the Handset Date and Time	19
Setting the Language	20
Setting Touch Tone or Pulse Dialing	20

Using the Handset	21
Making a Call	21
Adjusting the Volume During a Call	21
Inserting Pauses in a Number	22
Using Automated Dialing	23
Using the Speakerphone	24
Muting a Call	24
Putting a Call on Hold	24
Redialing a Number	25
Finding a Lost or Misplaced Handset	25
Using the Phonebook	26
Storing a New Number	26
Storing a Recently Called Number	28
Storing a Caller ID Number	28
Editing a Phonebook Entry	29
Deleting a Phonebook Entry	30
Sorting the Phonebook	30
Copying a Phonebook Entry	30
Calling a Number from the Phonebook	32
Using Caller ID	33
Reviewing the List of Caller ID Calls	33
Deleting Caller ID Calls	33
Multihandset Functions	34
Using the Intercom	34
Enabling Auto-Answer	35
Transferring Calls to Other Handsets	36
Conference Calling	36
Monitoring a Room	37

Using the Answering Machine	39
Setting Up the Answering Machine	39
Turning the Answering Machine On or Off	39
Setting the Date and Time	41
Setting Up Your Outgoing Message	41
Setting the Number of Rings Before the Answering Machine Picks Up	42
Setting the Security ID Number	42
Setting Voice Prompts	43
Recording a Memo	43
Using the Answering Machine	43
Checking Messages from the Base Station	43
Checking Messages from a Handset	43
Checking Messages Remotely	44
Message Forwarding	45
Screening Calls	46
Motorola Limited Warranty	47

Contents

Important Safety Instructions

Follow these safety precautions when using your cordless phone to reduce the risk of fire, electric shock and injury to persons or property:

Reduce risk of fire and shock by

1. Keep all slits and openings of the phone unblocked. Do not set the phone on a heating register or over a radiator. Ensure that proper ventilation is provided at the installation site.
2. Do not use while wet or while standing in water.
3. Do not use this product near water (for example, near a bath tub, kitchen sink, or swimming pool).
4. Do not allow anything to rest on the power cord. Place the power cord so that it will not be walked on.
5. Never insert objects of any kind into the product slits as that may result in fire or shock.
6. Unplug this product from the wall outlet before cleaning. Do not use liquid cleaners or aerosol cleaners. Use a damp cloth for cleaning.
7. Do not disassemble this product. If service or repair work is required, contact the Motorola address found in the back of this user's guide.
8. Do not overload wall outlets and extension cords.
9. Avoid using during an electrical storm. Use a surge protector to protect the equipment.
10. Do not use this cordless phone to report a gas leak, especially if you are in the vicinity of the gas line.

Unplug this cordless phone immediately from an outlet if:

- The power cord or plug is damaged or frayed.
- Liquid has been spilled into the product.
- The product has been exposed to rain or water. Do not retrieve the handset or base until after you have unplugged the power and phone from the wall. Then retrieve the unit by unplugged cords.
- The product has been dropped or the cabinet has been damaged.
- The product exhibits a distinct change in performance.

Installation Guidelines

1. Read and understand all instructions and save them for future reference.
2. Follow all warnings and instructions marked on the product.
3. Do not install this product near a bath tub, sink or shower.
4. Operate this phone using only the power source that is indicated on the marking label. If you are unsure of the power supply to your home, consult with your dealer or local power company.
5. Do not place this product on an unstable cart, stand or table. This product may fall, causing serious damage to the product.
6. Adjust only those controls that are covered by the operating instructions. Improper adjustment of other controls may result in damage and will often require extensive work to restore the product to normal operation.
7. Clean this product with a soft, damp cloth. Do not use chemicals or cleaning agents to clean this phone.

8. Use only the power supply that came with this unit. Using other power supplies may damage the unit.
9. Because cordless phones operate on electricity, you should have at least one phone in your home that isn't cordless, in case the power in your home goes out.
10. To avoid interference to nearby appliances, do not place the base of the cordless phone on or near a TV, microwave oven, or VCR.

FCC Information

This equipment complies with Parts 15 and 68 of the FCC rules and the requirements adopted by the Administrative Council for Terminal Attachments (ACTA).

A plug and jack used to connect this equipment to the premises wiring and telephone network must comply with applicable FCC Part 68 rules and requirements adopted by the ACTA. A compliant telephone cord and modular plug is provided with this product. It is designed to be connected to a compatible modular jack that is also compliant. See installation instructions for details.

Notification of Local Telephone Company

On the bottom of this equipment is a label that contains, among other information, a product identifier in the form US:AAAEQ##TXXXX. You must, upon request, provide this information to your telephone company.

The digits represented by ## in the product identifier indicate the Ringer Equivalency Number (REN) for this equipment. The REN is useful in determining the number of devices you may connect to your telephone line and still have all of these devices ring when your telephone number is called. In most (but not all) areas, the sum of the RENs of all devices connected to one line should not exceed 5. To be certain of the number of devices you may connect to your line as determined by the REN, contact your local telephone company.

Note: This equipment may not be used on coin service provided by the telephone company.

Connection to party line service is subject to state tariffs. Contact the state public utility commission, public service commission or corporation commission for information.

If your home has specially wired alarm equipment connected to the telephone line, ensure the installation of this cordless phone does not disable your alarm equipment. If you have questions about what will disable alarm equipment, consult your telephone company or a qualified installer.

Notice must be given to the telephone company upon permanent disconnection of your telephone from your line. The FCC requires that you connect your cordless telephone to the nationwide telephone network through a modular telephone jack (USOC RJ11C/RJ11W or RJ14C/RJ14W).

Rights of the Telephone Company

Should your equipment cause trouble on your line which may harm the telephone network, the telephone company shall, where practicable, notify you that temporary discontinuance of service may be required.

Where prior notice is not practical and the circumstances warrant such action, the telephone company may temporarily disconnect service immediately. In case of such temporary discontinuance, the telephone company must:

- Promptly notify you of such temporary discontinuance
- Afford you the opportunity to correct the situation

- Inform you of your right to bring a complaint to the Commission pursuant to procedures set forth in Subpart E of Part 68, FCC Rules and Regulations.

The telephone company may make changes in its facilities, equipment, operations, or procedures that could affect the operation of the equipment. If this happens, the telephone company will provide advance notice in order for you to make necessary modifications to maintain uninterrupted service.

Interference Information

This device complies with Part 15 of the FCC Rules. Operation is subject to the following two conditions:

- This device may not cause harmful interference.
- This device must accept any interference received, including interference that may cause undesired operation.

This equipment has been tested and found to comply with the limits for a Class B digital device, pursuant to Part 15 of the FCC Rules. These limits are designed to provide reasonable protection against harmful interference in a residential installation.

This equipment generates, uses, and can radiate radio frequency energy and, if not installed and used in accordance with the instructions, may cause harmful interference to radio communications. However, there is no guarantee that interference will not occur in a particular installation.

If this equipment does cause harmful interference to radio or television reception, which can be determined by turning the equipment on and off, the user is encouraged to try to correct the interference with one or more of the following measures:

- Reorient or relocate the receiving antenna (that is, the antenna for the radio or television that is "receiving" the interference).
- Reorient or relocate and increase the separation between the telecommunications equipment and the receiving antenna.
- Connect the telecommunications equipment into an outlet on a circuit different from that to which the receiving antenna is connected.

If these measures do not eliminate the interference, please consult your dealer or an experienced radio/television technician for additional suggestions. Also, the Federal Communications Commission has prepared a helpful booklet, "How to Identify and Resolve Radio/TV Interference Problems." This booklet is available from the U.S. Government Printing Office, Washington, D.C. 20402. Please specify stock number 004-000-00345-4 when ordering copies.

The FCC requires this product to be serviced only by Motorola or its authorized service agents.

CAUTION / WARNING: Changes or modifications not expressly approved by Motorola could void not only the user's authority to operate the equipment, but also the limited warranty.

Hearing Aid Compatibility

This telephone system meets the FCC standards for hearing aid compatibility.

Getting Started

Before you can use your telephone to make or answer calls, you must charge the battery. This section provides the step-by-step instructions you will need.

Battery Safety Instructions

- Do not burn, disassemble, mutilate, or puncture the battery. The battery contains toxic materials that could be released, resulting in injury.
- **Caution:** There is a risk of explosion if you replace the battery with an incorrect battery type. Use only the battery that came with your phone or an authorized replacement recommended by the manufacturer.
- Keep batteries out of the reach of children.
- Remove batteries if storing over 30 days.
- Do not dispose of batteries in fire, which could result in explosion.
- The rechargeable batteries that power this product must be disposed of properly and may need to be recycled. Refer to your battery's label for battery type. Contact your local recycling center for proper disposal methods.



Charging the Battery

- 1 Remove the battery door.
- 2 Insert the battery into the battery compartment.
- 3 Plug the battery connector into the receptacle in the battery compartment and replace the battery door.

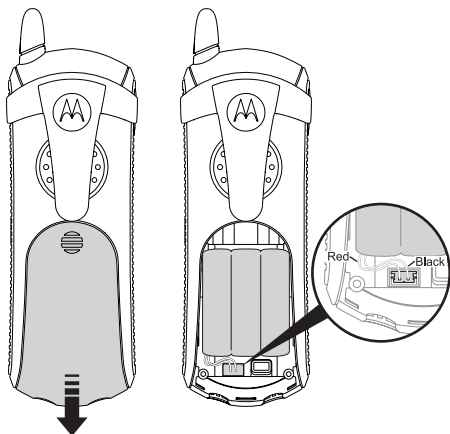

- 4 Plug the power cord into the back of the base and into an outlet.

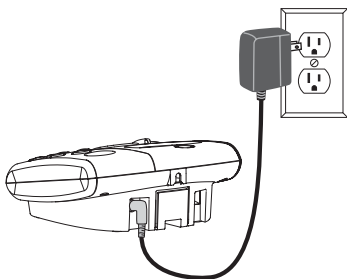

- 5 Rest the handset in the base so the charging LED lights.
- 6 For the initial charge, charge the battery for **at least 16 hours.**

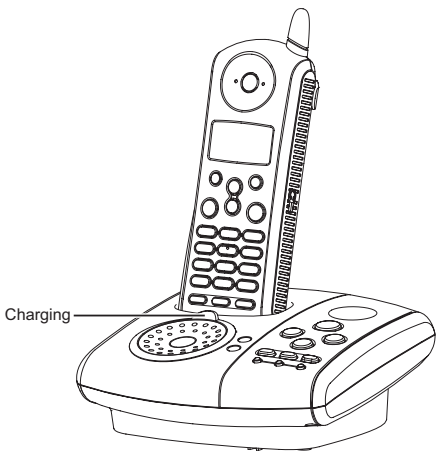

Note: Every time a battery is plugged in, the phone must be charged in the base for at least 10 seconds for the phone to properly restart.

Installing Backup Batteries

Four AAA alkaline batteries (not included) can be installed into the base as backup in case of a power outage.

- 1 With the back of the base facing you, press the cover latch to remove the battery compartment cover.

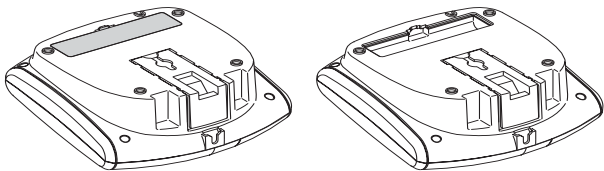

- 2 Insert four AAA alkaline batteries as directed on the compartment.
- 3 To replace the compartment cover, insert the tabs of the cover into the slots on the base station and press down until the cover clicks into place.

Note: The backup batteries discharge somewhat during each power outage. If your power fails often or for more than an hour, you should replace the batteries to ensure they are fresh whenever they are needed.

Using the Handset

The handset display, soft keys, and navigation keys are used to select the various features and functions of the handset. This section describes how to use these components so you can set up your preferences.

For step-by-step instructions on setting personal preferences, see “Setting Up.”

Using the Handset Display

The main display:

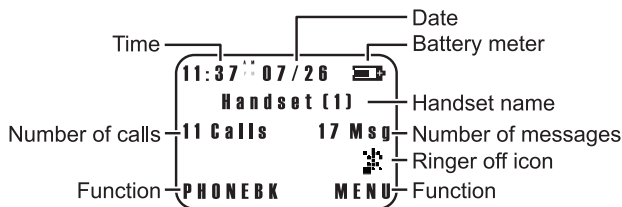

When the handset is not in use, the standby screen is displayed.

Note: Caller ID information is supplied only if you subscribe to caller ID service from your local phone company.

When the handset speakerphone is on, 📞 displays.

The menu display:

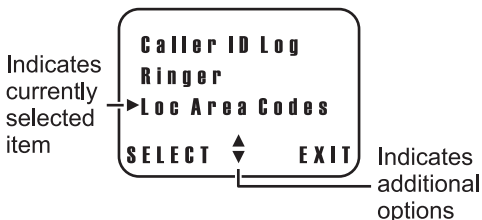

In a menu display, ▶ points to the currently selected item, and ▲ indicates there are more items above and below the currently selected item.

Using the Soft Keys

Two soft keys are used to select the functions shown above them on the display. The functions change as you move from one screen to the next. In this guide, soft key functions are shown as the function name. For example, if a step instructs you to “select **MENU**,” do so by pressing the soft key below **MENU**.

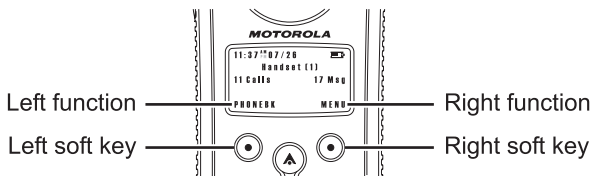

Using the Navigation Key

The navigation key is used to scroll up and down through menu items, lists of settings, caller ID and redial lists, and the phonebook.

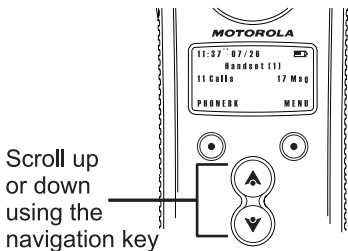

Installation

Once your MD760 is fully charged and ready for use, you can install it on a desktop or mount it to a wall. This section provides the step-by-step instructions you will need to install the phone.

Installing the Phone on a Desk

Once the battery is fully charged, plug the phone cord into the back of the phone and then into the phone jack on the wall.

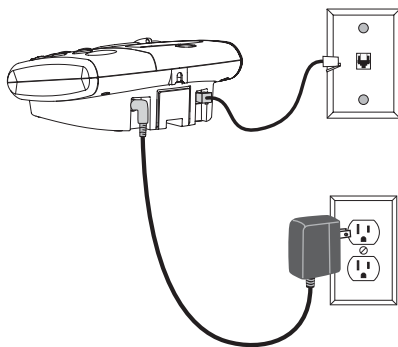

Installing the Phone on the Wall

The wall mount of your MD760 is located in the base of the phone. It works best with a wall mount bracket, which is available at most electronic stores.

- 1 Carefully slide and lift the wall mount from the base.

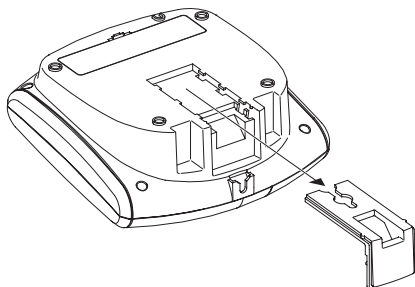

- 2 Turn the wall mount over so the key slot is facing upward. Align the holes of the wall mount with the feet of the base and push gently until the wall mount fits snugly into place.

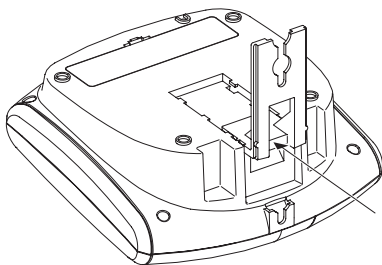

- 3 Plug the power cord into the back of the base and into an electrical outlet.
- 4 Plug one end of the telephone line cord into the jack on the back of the base.
- 5 Line up the tabs on the wall mount bracket with the holes on the back of the wall mount. Snap the wall mount firmly into place.

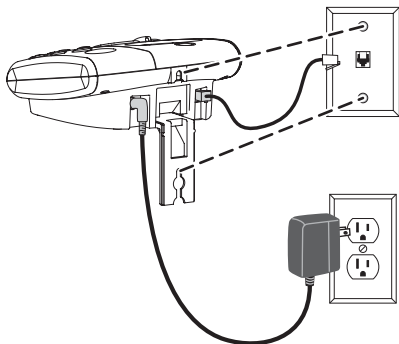

Setting Up

Once your expansion handset has been fully charged, you can set your own preferences.

Personalizing Your Handset

You can personalize each handset by setting unique ring tones, adjusting the ringer volume for day and night, and naming each handset so you can distinguish one from another.

Setting the Ring Volume

If you want the volume of your ringer to differ from daytime to nighttime, you can set a separate day volume and night volume.

- 1 Select **MENU**.
- 2 Scroll to **Ringer** and select **SELECT. Day Volume** is displayed, which sets the ringer volume from 6 AM to 9 PM.
- 3 Select **CHANGE** to scroll through the settings (off, low, medium, high). Each volume level plays as you select **CHANGE**. Stop at the volume level you want to set.

To change the night volume, scroll down to **Night Volume**, which sets the ringer volume from 9 PM to 6 AM, and repeat step 3.

- 4 Select **DONE**.

Select **EXIT** to return to the standby screen, or scroll to a different menu option.

Setting the Ring Tone

If you subscribe to a caller ID service, you can set a specific ring tone for numbers stored in your handset's phonebook and another for all other incoming calls.

- 1 Select **MENU**.
- 2 Scroll to **Ringer** and select **SELECT**.
- 3 Scroll down to **Ring Tone**, which sets the ring tone for incoming calls.
- 4 Select **CHANGE** to scroll through the ring tones. Each tone plays as you select **CHANGE**. Stop at the ring tone you want to set.
- 5 Scroll down to **PHONEBOOK TONE**, which sets the ring tone for numbers stored in your handset's phonebook. Repeat step 4 to select a tone.
- 6 Select **DONE**.
- 7 Select **EXIT** to return to the standby screen, or scroll to a different menu option.

Setting Key Beeps On or Off

The handset beeps each time you press a key. You can turn this feature off (the handset beeps by default), or set it to beep only when the ringer is on.

- 1 Select **MENU**.
- 2 Scroll to **Ringer** and select **SELECT**.
- 3 Scroll to **Key Beeps** and select **SELECT**.

- 4 Select **CHANGE** to scroll through the options (**ON**, **OFF**, or **LINKED to RINGER**). When your choice displays, select **SELECT**.

Note: For the **LINKED to RINGER** option, key beeps are on when the ringer is on, and off when the ringer is off.

Setting the Charging LED

Whenever the handset is resting in the charging cradle, the charging LED illuminates. You can control the brightness of the charging LED.

- 1 Select **MENU** and then scroll to and select **CHARGING LED**.
- 2 Select the brightness level you prefer. You can select **ON**, **OFF**, or **NIGHT TIME OFF**, which turns the charging LED off from 9 PM to 6 AM.

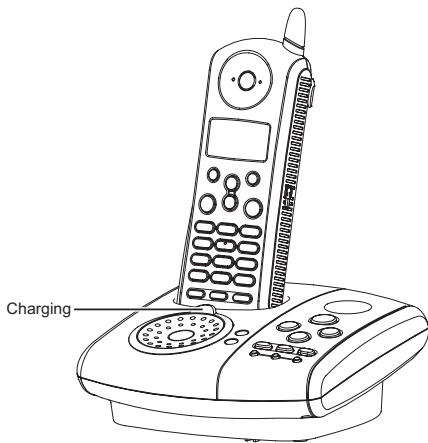

Naming a Handset

When you register a handset, it is assigned a default name of **Handset(x)**, where *x* can be 1, 2, 3, 4, 5, 6, 7, or 8. You can change the name to something more useful, for example a location (**Kitchen**) or someone's name (**Evan**). Naming a handset makes it easy to select the handset from a list (for example, to intercom another handset).

If you name a handset, the handset number remains part of the name, for example, **Kitchen(2)**.

- 1 Select **MENU**.
- 2 Scroll to **Name handset** and select **SELECT**.
- 3 Enter the name you want to use (up to 12 characters). The flashing underline shows the input cursor position. Select **DELETE** to erase characters to the left of the input cursor.

The following table shows how many times to press each button on the handset to enter letters and special characters.

Button	Number of Presses				
	1	2	3	4	5
1	space	–	*	,	1
2	A	B	C	(2
3	D	E	F)	3
4	G	H	I	#	4
5	J	K	L	/	5
6	M	N	O	'	6
7	P	Q	R	S	7
8	T	U	V	?	8
9	W	X	Y	Z	9

The first letter of the entry is an uppercase letter. To change the entry from uppercase to lowercase, press *. A flashing square indicates that you are in the uppercase text entry mode. A flashing cursor indicates that you are in the lowercase text entry mode.

- 4 Select **DONE**.
- 5 Select **EXIT** to return to the standby screen, or scroll to a different menu option.

Storing Area Codes for Caller ID

You can store up to 5 area codes to make it easy to dial numbers from your list of caller ID calls. For example, if you store 954 in 10-digit format, when you receive a call from that area code, the phone number is stored in your call list with all 10 digits. The number will then be in the correct format for you to dial directly from the call list without any reformatting.

Each area code can be:

- **7-digit format**

You do not have to dial the area code to call numbers in this area code.

- **10-digit format**

You have to dial the 3-digit area code + 7-digit phone number to call numbers in this area code.

- **11-digit format**

You have to dial the 1 + 3-digit area code + 7-digit phone number to call numbers in this area code.

Important: This feature should not be used in regions where the same area code can be used to dial 10-digit local numbers or 11-digit long distance numbers. Disregard this setup if your phone will be used in such regions.

Note: This section applies only if you subscribe to caller ID service from your local phone company.

- 1 Select **MENU**.
- 2 Scroll to **LOC AREA CODE** and select **SELECT**.
- 3 Enter the first area code.

- 4 Select **FORMAT** to scroll through the formats. Stop at the format you want to set for the area code, then scroll down to move to the next area code.
- 5 Repeat steps 3 and 4 to store up to 4 more area codes. When you are finished, select **DONE**.
- 6 Select **EXIT** to return to the standby screen, or scroll to a different menu option.

Setting the Handset Date and Time

To set the date and time on the answering machine, see “Using the Answering Machine.”

- 1 Select **MENU**.
- 2 Scroll to **Date/Time** and select **SELECT**.
- 3 Enter the time. (2 digits are required for both hour and minutes, so use a leading 0 for 1-digit values.)
- 4 If using a 12-hour clock, select **AM/PM** to switch between am and pm.
- 5 Scroll down to move the next field.
- 6 Select **CHANGE** to change the time format (12 or 24 hour clock). Scroll down to move to the next field.
- 7 Select **CHANGE** to select date format (MM/DD or DD/MM).
- 8 Scroll down to move the next field.
- 9 Enter the current date.
- 10 Select **DONE**.
- 11 Select **EXIT** to return to the standby screen, or scroll to a different menu option.

Setting the Language

- 1 Select **MENU**.
- 2 Scroll to **Language** and select **SELECT**.
- 3 Scroll until ► points to the language you want.
- 4 Select **DONE**.
- 5 Select **EXIT** to return to the standby screen, or scroll to a different menu option.

Setting Touch Tone or Pulse Dialing

Your handset uses touch tone dialing by default. Do not change this setting unless touch tone service is not available in your area.

- 1 Select **MENU**.
- 2 Scroll to **Tone/Pulse**.
- 3 Scroll or press **CHANGE** to switch between **Tone** and **Pulse**.
- 4 Select **DONE**.
- 5 Select **EXIT** to return to the standby screen, or scroll to a different menu option.

Using the Handset

Making a Call

Press **ON**. When you hear the dial tone, dial the number.

OR

Enter the phone number, then press **ON**. This lets you see the phone number on the display before the number is dialed.

During a call, a timer on the display shows the length of the call.

When you are finished talking, press **OFF** to hang up.

Press **ON** or **HANDSFREE** to answer using the speakerphone.

If you have call waiting service, press **ON** to answer the second call.

Using the Handset

Adjusting the Volume During a Call

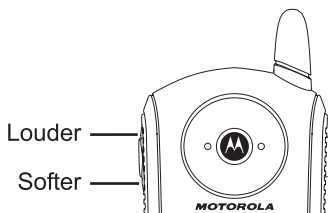

Inserting Pauses in a Number

When you call a number featuring a pause, the phone waits 3 seconds before transmitting the next digits in the dialing sequence. This is useful, for example, when you have to dial 9 to get a dial tone or for accessing a voicemail system.

To insert a pause within a number, press the pound key (#) twice. A “P” is displayed on the handset display.

Using Automated Dialing

You can retrieve numeric information (like a PIN or credit card number) from the phonebook during a phone call. This feature is useful when using automated response system.

For example, if you frequently access your bank account information over the phone, you can store your account number and PIN in the phonebook, and then access them during the call instead of entering them manually each time.

- 1 While on a call, scroll until ► points to the entry you want to recall.
- 2 Press **DIAL**.
- 3 Repeat steps 1 and 2 as often as necessary to complete your transaction.

Using the Speakerphone

To make a call using the speakerphone, press **HANDSFREE** and dial the number.

For optimal speakerphone sound quality, make sure the belt clip is on. This raises the handset up so it is not lying flat (the speakerphone is on the back of the handset).

When the speakerphone is on,  appears on the handset display.

If you have call waiting, press **ON** to answer the second call while using the speakerphone.

To adjust the speakerphone volume, press the volume up or volume down key on the side of the handset.

To toggle between the handset and the speakerphone, press **HANDSFREE**.

When you are finished talking, press **OFF** to hang up and turn the speakerphone off.

Note: Pressing Handsfree while in the caller ID list, redial list, or phonebook turns the speakerphone on and dials the selected number.

Muting a Call

Press **MUTE**. To unmute the call, press **UNMUTE**.

Putting a Call on Hold

Press **HOLD**.

To return to the call, press **UNHOLD** or **ON**.

When a call is on hold, you can use the intercom features (see the “Using the Intercom” section).

Redialing a Number

To redial the last number dialed, press **ON** and then press **REDIAL**.

To redial one of the last 5 numbers you dialed:

- 1 Press **REDIAL**
- 2 Scroll until **▶** points to the number you want to redial.
- 3 Press **DIAL** or **ON** or **HANDSFREE**.

If a number in the redial list matches a number in your phonebook, the phonebook name and number display in the redial list.

Finding a Lost or Misplaced Handset

To page a missing handset, press **PAGE** on the base station. All handsets registered to the base station will start beeping.

To stop paging all handsets, press **PAGE** again on the base station or press **EXIT** or **OFF** on any handset. To stop paging an individual handset, press **OK** on the handset.

Using the Phonebook

Storing numbers in the phonebook makes it easy to dial numbers you call frequently. You can enter numbers directly into the phonebook or add them from the caller ID or redial list.

Each handset has its own phonebook, which can hold 50 names and numbers. The base has a 48-entry phonebook that is shared among all handsets.

Storing a New Number

- 1 Select **PHONEBK**.
- 2 To store a number in the base phonebook, select **SHARED**. To store a number in the handset phonebook, select **PRIVATE**.
- 3 Scroll to **NEW ENTRY** and select **SELECT**.
- 4 Enter the name (up to 12 characters). The flashing underline shows the input cursor position. Select **DELETE** to erase characters to the left of the input cursor.

The following table shows how many times to press each button on the handset to enter letters and special characters.

Button	Number of Presses				
	1	2	3	4	5
1	space	-	*	,	1
2	A	B	C	(2
3	D	E	F)	3
4	G	H	I	#	4
5	J	K	L	/	5
6	M	N	O	'	6
7	P	Q	R	S	7
8	T	U	V	?	8
9	W	X	Y	Z	9

The first letter of the entry is an uppercase letter. To change the entry from uppercase to lowercase, press *. A flashing square indicates that you are in the uppercase text entry mode. A flashing cursor indicates that you are in the lowercase text entry mode.

- 5 Scroll down.
- 6 Enter the phone number (up to 24 digits). Select **DELETE** to erase characters to the left of the input cursor.
- 7 Scroll down.
- 8 To set the tones of incoming calls for this number, select **CHANGE**. A tone plays each time you select **CHANGE**. Stop at the ring tone you want to set.
- 9 Select **DONE**.

Storing a Recently Called Number

- 1 Press **REDIAL**. The display shows the last five numbers you dialed, with the most recent number at the top.
- 2 Scroll until **▶** points to the number you want to store.
- 3 Press **STORE**.
- 4 Enter the name (up to 12 characters). The flashing underline shows the input cursor position. Select **DELETE** to erase characters to the left of the input cursor. See *Storing a New Number* for information on entering text.
- 5 Scroll down until the phone number displays in the Number: field. Select **DELETE** to erase characters to the left of the input cursor if modifications need to be made.
- 6 Scroll down.
- 7 To set the tones of incoming calls for this number, select **CHANGE**. A tone plays each time you select **CHANGE**. Stop at the ring tone you want to set.
- 8 Select **DONE**.

Storing a Caller ID Number

- 1 From the caller ID list, select **OPTIONS**.
- 2 Scroll to **STORE** and select **SELECT**. The caller's name is displayed in the Name field.

If changes need to be made, select **DELETE** to erase characters to the left of the input cursor. See *Storing a New Number* for information on entering text.

- 3 Scroll down until the Number field is displayed.
If changes need to be made, select **DELETE** to erase characters to the left of the input cursor.
- 4 Scroll down.
- 5 To set the tones of incoming calls for this number, select **CHANGE**. A tone plays each time you select **CHANGE**. Stop at the ring tone you want to set.
- 6 Select **DONE**.

Editing a Phonebook Entry

- 1 Select **PHONEBK**.
- 2 Scroll down until ► points to the phonebook entry you want to edit.
- 3 Select **OPTIONS**.
- 4 Scroll down to **EDIT** and select **SELECT**.

To edit the name, select **DELETE** to erase characters to the left of the input cursor. See *Storing a New Number* for information on entering text.

The first letter of the entry is an uppercase letter. To change the entry from uppercase to lowercase, press *. A flashing square indicates that you are in the uppercase text entry mode. A flashing cursor indicates that you are in the lowercase text entry mode.

- 5 Scroll down to the phone number field and modify as necessary.
- 6 Scroll down.
- 7 To set the tones of incoming calls for this number, select **CHANGE**. A tone plays each time you select **CHANGE**. Stop at the ring tone you want to set.

- 8 Select **DONE**.

Deleting a Phonebook Entry

- 1 Select **PHONEBK**.
- 2 Scroll down until **▶** points to the phonebook entry you want to delete.
- 3 Select **OPTIONS**.
- 4 Scroll down to **DELETE** and select **SELECT**.

Sorting the Phonebook

Phonebook entries are stored in the order in which they were saved by default. However, you can set the phonebook to sort entries alphabetically.

Once sorted, a phonebook cannot be unsorted or reset to its previous list order.

- 1 Select **PHONEBK** and scroll to any phonebook entry.
- 2 Select **OPTIONS**.
- 3 Scroll down to **SORT PHONEBK** and select **SELECT**. The option “Alphabetically sort phonebk?” is displayed.
- 4 Select **YES** or **NO**.

Copying a Phonebook Entry

You can copy phonebook entries from your private phonebook to the shared phonebook and vice versa.

- 1 Select **PHONEBK** and scroll to any phonebook entry.
- 2 Select **OPTIONS**.
- 3 When in your private phonebook, to copy an entry to the shared phonebook, select **COPY TO SHARED**.

When in the shared phonebook, to copy an entry to your private phonebook, select **COPY TO PRVT.**

Calling a Number from the Phonebook

- 1 Select **PHONEBK**.
- 2 Scroll down until **▶** points to the phonebook entry you want to call.

To search numerically, press the numbers of the phonebook entry that you want to dial.

- 3 Press **ON** or **HANDSFREE**.

To speed dial, select **PHONEBK**, enter the location number, and then press **ON**.

Using Caller ID

If you subscribe to caller ID service, the caller's name and/or number are displayed when you receive an incoming call. If information on the caller is not available, or if you do not subscribe to caller ID service, **INCOMING CALL** is displayed.

Reviewing the List of Caller ID Calls

The handset can store up to 40 caller ID records.

- 1 Scroll down to view the recent calls list. The most recent call is listed first.
- 2 Scroll to review more calls.
- 3 To call the number, press **ON** or **HANDSFREE**.

To reformat the number before you call, select **FORMAT** until the correct format displays.

For example, if a number you want to call is stored with the area code (10 digits), but you do not use the area code to call this number, press **FORMAT** until the number appears without the area code (7 digits).

Deleting Caller ID Calls

- 1 From the caller ID list, select **OPTIONS**.
- 2 Scroll to **DELETE** (to delete the current caller ID entry) or **DELETE ALL** (to delete all caller ID records) and select **SELECT**.

If you select Delete All, select **YES** at the Delete All? prompt.

- 3 Press **NO** to return to the caller ID list.

Multihandset Functions

The following multihandset functions require at least 2 (up to 8) handsets registered to the base station.

You can expand your phone system by adding Motorola MD Series expansion handsets (up to 8). Expansion handsets do not require connection to a phone line. You can place the handset and its charging base anywhere a standard electrical outlet is available.

With multiple handsets, you can:

- Conference call
- Talk handset to handset on the intercom
- Set up handsets to automatically answer intercom calls
- Transfer calls from one handset to another
- Monitor a room

To order expansion handsets, call:

1-800-353-2729 U.S.A.

1-800-461-4575 Canada

1-888-390-6456 TTY (Text Telephone)

Or visit us online: www.motorola.com/cordless

Using the Intercom

The handsets and base station can be used as an intercom system, allowing you to talk to people in other parts of your home.

- 1 Press **INTERCOM**.

If you only have one additional handset, pressing **INTERCOM** automatically pages the handset.

If you have multiple handsets, a list of handsets is displayed.

- 2 Scroll to and select the handset you want to page.
- 3 Select **PAGE**. The other phone is paged.

To answer a page, press **OK**.

If your page is not answered after two minutes, or if the person you are paging selects **EXIT** or presses **OFF**, **NO ANSWER** is displayed on your handset and paging stops.

- 4 To end an intercom session, press **OFF**.

Enabling Auto-Answer

You can program a handset or base station to automatically answer a page by turning on the speakerphone. The handsets are not programmed to do this by default.

- 1 Select **MENU**.
- 2 Scroll to and select **INTERCOM SETUP**.
- 3 Scroll to and select one of the following options:
 - AFTER 1 RING:** The handset automatically answers a page after one ring.
 - AFTER 3 RINGS:** The handset automatically answers a page after three rings.
- 4 Select **EXIT** to return to the standby screen, or scroll to a different menu option.

Transferring Calls to Other Handsets

- 1 Select **HOLD**.
- 2 Press **INTERCOM**.
If you only have one additional handset, pressing **INTERCOM** automatically pages the handset. Continue to step 5.
- 3 Scroll to and select the handset to which you want to transfer the call.
- 4 Select **PAGE**.
- 5 If you want to announce the transfer to the other handset, speak once the page has been answered.
- 6 Select **UNHOLD**. The call is transferred to the other handset and all three individuals are on the call.
- 7 Press **OFF** to disconnect.

Conference Calling

Multiple handsets can participate in a call.

When only one handset is on a call, **LINE IN USE** is displayed. Once additional handsets join the call, **ON CONFERENCE** is displayed.

To connect to a call from an additional handset, press **ON** or **HANDSFREE**.

To join a conference call, press **ON** from the base station.

To disconnect from a conference call, press **OFF** on the handset.

Monitoring a Room

Room monitoring allows you to place a handset in a room and listen to the sounds in that room from another handset.

- 1 Place a handset in the room to be monitored.
- 2 On that handset, select **MENU**.
- 3 Scroll to **MONITOR ROOM** and select **SELECT. READY TO MONITOR ROOM** is displayed.
- 4 On the handset you want to listen from, press **INTERCOM**.

If you only have one additional handset, pressing **INTERCOM** automatically pages the handset.

- 5 If you have multiple additional handsets, scroll to the handset you want to monitor, and select **PAGE**.

The handset being monitored automatically answers the page, the microphone is turned on, and the speaker is turned off.

MONITORING (HANDSET NAME) is displayed on the handset from which you are monitoring.

To stop monitoring, select **CANCEL** or **OFF** on either handset. Monitoring also stops whenever an incoming call is answered.

Using the Answering Machine

The answering machine stores up to 15 minutes of messages and/or memos. You can listen to your messages from the base station, from the handset, or remotely. You can also set your phone to automatically forward answering machine messages to another phone number.

The answering machine at a glance:

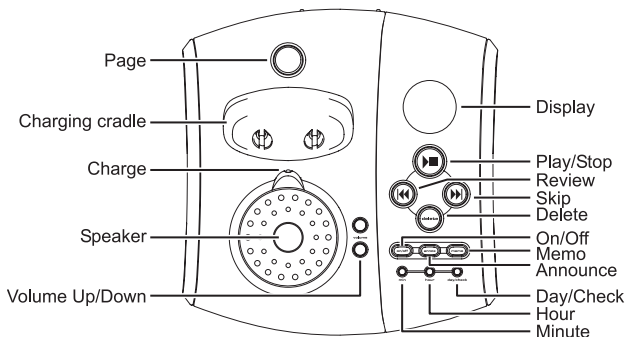

Setting Up the Answering Machine

You can set up the answering machine from a handset or the base station.

Turning the Answering Machine On or Off

- 1 Select **MENU** and then scroll to and select **ANS MACH SETUP**.

- 2 Scroll to and select **ANSWER ON/OFF**.
- 3 Scroll to and select **ON** or **OFF** and then select **DONE**.

Setting the Date and Time

To set the date and time, press and the **DAY/CHECK**, **HOOR**, and **MINUTE** buttons on the base until the correct setting is heard.

Setting Up Your Outgoing Message

You can record a personal outgoing message (OGM) that plays when you receive a call but cannot answer. If you do not record a personal message, a prerecorded greeting will play.

Recording an Outgoing Message

To record an outgoing message from the base, press and hold **ANNCE**. Release the button to stop recording.

To record an outgoing message from the handset:

- 1 Select **MENU** and then scroll to and select **ANS MACH SETUP**.
- 2 Scroll to and select **OUTGOING MSG**.
- 3 Scroll to and select **RECORD OGM**.
- 4 Select **YES** to record your message.
- 5 When you are finished recording, select **END**.

To replay your message, select **REPLAY**.

Erasing an Outgoing Message

You can erase a personally recorded message; the default greeting cannot be erased.

- 1 Select **MENU** and then scroll to and select **ANS MACH SETUP**.
- 2 Scroll to and select **OUTGOING MSG**.
- 3 Scroll to and select **ERASE OGM**.

4 Select **YES**.

To erase an outgoing message from the base, press **ANNCE** to play the message. As the message plays, press **DEL**.

Setting the Number of Rings Before the Answering Machine Picks Up

You can specify how many times you want your phone to ring before the answering machine picks up the call.

- 1 Select **MENU** and then scroll to and select **ANS MACH SETUP**.
- 2 Scroll to and select **RING NUMBER**.
- 3 Scroll to and select **3, 4, 5, 6, or TOLLSAVER** and then select **DONE**.

Toll Saver sets the answering machine to pick up the call after 3 rings when new messages are present, or after 5 rings when there are no new messages.

Using this feature, if you call long distance to check your messages and the phone does not pick up after the third ring, you can hang up and avoid the toll charge because no new messages are waiting.

Setting the Security ID Number

The security ID number allows you to remotely access your messages from any touch-tone phone.

- 1 Select **MENU** and then scroll to and select **ANS MACH SETUP**.
- 2 Scroll to and select **SECURITY ID**.
- 3 Enter your 3-digit security number and then select **DONE**.

Setting Voice Prompts

If you have a Canadian model MD760, you can set your voice mail prompts to either English or French.





- 1 Select **MENU** and then scroll to and select **ANS MACH SETUP**.
- 2 Scroll to and select **VOICE PROMPT**.
- 3 Scroll to and select either **ENGLISH** or **FRENCH**.

Recording a Memo

To record a message that you can play back later, press and hold **MEMO** on the base station. Release the button to stop recording.

Using the Answering Machine

Checking Messages from the Base Station

- | | |
|---|---------------------------|
| Press  | to play and stop messages |
| Press  | to skip forward |
| Press  | to skip backward |
| Press  | to delete message |

Checking Messages from a Handset

- 1 Select **MENU**, then scroll to and select **MESSAGES**.
- 2 Scroll to and select the function you want. The functions are:
 - 1: **REVIEW**
 - 2: **PLAY/STOP**
 - 3: **SKIP**

4: ANSWER ON/OFF

5: MEMO

7: REPEAT MENU

0: ERASE

Checking Messages Remotely

If you have a touch-tone phone, you can access your messages remotely.

- 1 Call your home.
- 2 When the answering machine picks up the call, press * and then enter your security ID number. A synthesized voice prompts you with instructions.
- 3 To skip the voice prompts and operate the base station directly, press the appropriate number key on the phone. The functions are:

Press 2 abc	to play/stop messages
Press 3 def	to skip forwards
Press 1 ↵	to skip backwards
Press 4 ghi	to turn the answering machine on/off
Press 5 jkl	to record a memo
Press 7 pqrs	to repeat the menu
Press 0 oper	to delete the message

Message Forwarding

Your Motorola phone can be set to automatically forward answering machine messages to another phone number.

To set up the phone number:

- 1 Select **MENU** and then scroll to and select **ANS MACH SETUP**.
- 2 Scroll to and select **FORWARD MSGS**.
- 3 Scroll to and select **SET FWD NUMBER**.
- 4 Enter the phone number to which you want to forward messages and then select **DONE**. If a pause is required, press the pound key (#) twice.
- 5 Scroll to and select **FORWARD ON/OFF**.
- 6 Select **ENABLE** and then select **DONE**.

To activate message forwarding, quickly press and release the **MEMO** button on the base. The message **FWD ANSWER ON** is displayed.

With Message Forwarding activated, the next time a message is received, the answering machine will call the phone number you specified. When you answer the call, you will be prompted for your security code. See “Setting the Security ID Number” for details. For more information retrieving your message, see “Checking Messages Remotely.”

To disable message forwarding, press and release **MEMO** again.

Screening Calls

You can screen a call by allowing the answering machine to pick up and listening to the message as it is being recorded.

- 1 When **RECORDING INCOMING MESSAGE** is displayed, select **SCREEN**.
- 2 To answer the call, press **ON**. To stop listening to the incoming message, press **OFF**.

Motorola Limited Warranty

Motorola Limited Warranty

for Consumer Products, Accessories, and Software
Purchased in the United States or Canada

What Does this Warranty Cover?

Subject to the exclusions contained below, Motorola, Inc. warrants its cordless telephones ("Products"), Motorola-branded or certified accessories sold for use with these Products ("Accessories"), and Motorola software contained on CD-ROMs or other tangible media and sold for use with these Products ("Software") to be free from defects in materials and workmanship under normal consumer usage for the period(s) outlined below. This limited warranty is a consumer's exclusive remedy, and applies as follows to new Motorola Products, Accessories and Software purchased by consumers in the United States or Canada, which are accompanied by this written warranty:

Products and Accessories as defined above, unless otherwise provided for below. Length of coverage: one (1) year from the date of purchase by the first consumer purchaser of the product unless otherwise provided for below.

- **Decorative Accessories and Cases.** Decorative covers, bezels, PhoneWrap® covers and cases. Length of coverage: limited lifetime warranty for the lifetime of ownership by the first consumer purchaser of the product.
- **Monaural Headsets.** Ear buds and boom headsets that transmit mono sound through a wired connection. Length of coverage: limited lifetime warranty for the lifetime of ownership by the first consumer purchaser of the product.

- **Products and Accessories that are Repaired or Replaced.** Length of coverage: The balance of the original warranty or for ninety (90) days from the date returned to the consumer, whichever is longer.
- **Software.** Applies only to physical defects in the media that embodies the copy of the software (e.g. CD-ROM, or floppy disk). Length of coverage: ninety (90) days from the date of purchase.

Exclusions

Normal Wear and Tear. Periodic maintenance, repair and replacement of parts due to normal wear and tear are excluded from coverage.

Batteries. Only batteries whose fully charged capacity falls below 80% of their rated capacity and batteries that leak are covered by this limited warranty.

Abuse & Misuse. Defects or damage that result from: (a) improper operation, storage, misuse or abuse, accident or neglect, such as physical damage (cracks, scratches, etc.) to the surface of the product resulting from misuse; (b) contact with liquid, water, rain, extreme humidity or heavy perspiration, sand, dirt or the like, extreme heat, or food; (c) use of the Products or Accessories for commercial purposes or subjecting the Product or Accessory to abnormal usage or conditions; or (d) other acts which are not the fault of Motorola, are excluded from coverage.

Use of Non-Motorola Products and Accessories. Defects or damage that result from the use of Non-Motorola branded or certified Products, Accessories, Software or other peripheral equipment are excluded from coverage.

Unauthorized Service or Modification. Defects or damages resulting from service, testing, adjustment, installation, maintenance, alteration, or modification in any way by someone other than Motorola, or its authorized service centers, are excluded from coverage.

Altered Products. Products or Accessories with (a) serial numbers or date tags that have been removed, altered, or obliterated; (b) broken seals or that show evidence of tampering; (c) mismatched board serial numbers; or (d) nonconforming or non-Motorola housings, or parts, are excluded from coverage.

Communication Services. Defects, damages, or the failure of Products, Accessories or Software due to any communication service or signal you may subscribe to or use with the Products, Accessories or Software is excluded from coverage.

Software Embodied in Physical Media. No warranty is made that the software will meet your requirements or will work in combination with any hardware or software applications provided by third parties, that the operation of the software products will be uninterrupted or error free, or that all defects in the software products will be corrected.

Software NOT Embodied in Physical Media. Software that is not embodied in physical media (e.g. software that is downloaded from the internet), is provided "as is" and without warranty.

Who is Covered

This warranty extends to the first end-user purchaser, only.

What will Motorola Do?

Motorola, at its option, will at no charge repair, replace or refund the purchase price of any Products, Accessories or Software that does not conform to this warranty. We may use functionally equivalent reconditioned/refurbished/pre-owned or new Products, Accessories or parts. No data, software or applications added to your Product, Accessory or Software, including but not limited to personal contacts, games and ringer tones, will be reinstalled. To avoid losing such data, software and applications please create a back up prior to requesting service.

How to Get Warranty Service or Other Information

In the USA, call:

1-800-353-2729

TTY 1-888-390-6456

In Canada, call:

1-800-461-4575

TTY 1-888-390-6456

For accessories and software, please call the telephone number designated above for the product with which they are used. You will receive instructions on how to ship the Products, Accessories or Software, at your expense, to a Motorola Authorized Repair Center. To obtain service, you must include: (a) a copy of your receipt, bill of sale or other

comparable proof of purchase; (b) a written description of the problem; (c) the name of your service provider, if applicable; (d) the name and location of the installation facility (if applicable) and, most importantly; (e) your address and telephone number.

What Other Limitations Are There?

ANY IMPLIED WARRANTIES, INCLUDING WITHOUT LIMITATION THE IMPLIED WARRANTIES OF MERCHANTABILITY AND FITNESS FOR A PARTICULAR PURPOSE, SHALL BE LIMITED TO THE DURATION OF THIS LIMITED WARRANTY, OTHERWISE THE REPAIR, REPLACEMENT, OR REFUND AS PROVIDED UNDER THIS EXPRESS LIMITED WARRANTY IS THE EXCLUSIVE REMEDY OF THE CONSUMER, AND IS PROVIDED IN LIEU OF ALL OTHER WARRANTIES, EXPRESS OR IMPLIED. IN NO EVENT SHALL MOTOROLA BE LIABLE, WHETHER IN CONTRACT OR TORT (INCLUDING NEGLIGENCE) FOR DAMAGES IN EXCESS OF THE PURCHASE PRICE OF THE PRODUCT, ACCESSORY OR SOFTWARE, OR FOR ANY INDIRECT, INCIDENTAL, SPECIAL OR CONSEQUENTIAL DAMAGES OF ANY KIND, OR LOSS OF REVENUE OR PROFITS, LOSS OF BUSINESS, LOSS OF INFORMATION OR DATA, SOFTWARE OR APPLICATIONS OR OTHER FINANCIAL LOSS ARISING OUT OF OR IN CONNECTION WITH THE ABILITY OR INABILITY TO USE THE PRODUCTS, ACCESSORIES OR SOFTWARE TO THE FULL EXTENT THESE DAMAGES MAY BE DISCLAIMED BY LAW.

Some states and jurisdictions do not allow the limitation or exclusion of incidental or consequential damages, or limitation on the length of an implied warranty, so the above limitations or exclusions may not apply to you. This warranty gives you specific legal rights, and you may also have other rights that vary from state to state or from one jurisdiction to another.

Laws in the United States and other countries preserve for Motorola certain exclusive rights for copyrighted Motorola software such as the exclusive rights to reproduce and distribute copies of the Motorola software. Motorola software may only be copied into, used in, and redistributed

with, the Products associated with such Motorola software. No other use, including without limitation disassembly of such Motorola software or exercise of the exclusive rights reserved for Motorola, is permitted.

Visit our website at:
www.motorola.com



MOTOROLA

514779-001
08/04

MGBI