

WARNING

TO PREVENT FIRE OR SHOCK HAZARD, DO NOT USE THIS PLUG WITH AN EXTENSION CORD, RECEPTACLE OR OTHER OUTLET UNLESS THE BLADES CAN BE FULLY INSERTED TO PREVENT BLADE EXPOSURE. TO PREVENT FIRE OR SHOCK HAZARD, DO NOT EXPOSE THIS APPLIANCE TO RAIN OR MOISTURE.



The lightning flash with arrowhead symbol, within an equilateral triangle is intended to alert the user to the presence of uninsulated 'dangerous voltage' within the product's enclosure that may be of sufficient magnitude to constitute a risk of electric shock to persons.

CAUTION

**RISK OF ELECTRIC SHOCK
DO NOT OPEN**

CAUTION: TO REDUCE THE RISK OF ELECTRIC SHOCK DO NOT REMOVE COVER (OR BACK), NO USER SERVICEABLE PARTS INSIDE. REFER SERVICING TO QUALIFIED SERVICE PERSONNEL.



The exclamation point within an equilateral triangle is intended to alert the user to the presence of important operating and maintenance (servicing) instructions in the literature accompanying the appliance.

IMPORTANT SAFETY PRECAUTIONS

INSTALLATION INSTRUCTION PRECAUTIONS:

- Never install telephone wiring during a lightning storm.
- Never install telephone jacks in wet locations unless the jack is specifically designed for wet locations.
- Never touch uninsulated telephone wires or terminals unless the telephone line has been disconnected at the network interface.
- Use caution when installing or modifying telephone lines.

Before using your telephone equipment, basic safety precautions must always be followed to reduce the risk of fire, electric shock and injury to persons, including the following:

1. Read and understand all instructions.
2. Follow all warnings and instructions marked on this product.
3. Unplug this product from the wall telephone jack and power outlet before cleaning. Do not use liquid cleaners or aerosol cleaners. Use a damp cloth for cleaning.
4. Do not use this product near water- for example, near a bathtub, washbowl, kitchen sink, or laundry tub, in a wet basement, or near a swimming pool.
5. Do not place this product on an unstable cart, stand, tripod, bracket, or table. The product may fall, causing serious injury and serious damage to the product.
6. Slots and openings in the cabinet and in the back or bottom are provided for ventilation and to ensure reliable operation of the product and to protect it from overheating. These openings must not be blocked or covered. The openings should never be blocked by placing the product on a bed, sofa, rug, or other similar surface. This product should never be placed near or over a radiator or heat

IMPORTANT SAFETY PRECAUTIONS (CONTINUED)

- source. This product should not be placed in an enclosed environment unless proper ventilation is provided.
7. This product should be operated only from the type of power source indicated on the marking label. If you are not sure of the type of power supply to your home, consult your dealer or local power company.
 8. Do not allow anything to rest on the power cord. Do not locate this product where the cord will be abused by persons walking on it. Do not attach power cord to building surfaces.
 9. Do not overload wall outlets and extension cords as this can result in the risk of fire or electric shock.
 10. Never push objects of any kind into this product through openings as they may touch dangerous voltage points or short out parts that could result in fire or electric shock. Never spill or spray any type of liquid on the product.
 11. To reduce the risk of electric shock, do not disassemble this product, but take it to a qualified serviceman when some service or repair work is required. Opening or removing covers may expose you to dangerous voltages or other risks. Incorrect re-assembly can cause electric shock when the appliance is subsequently used.
 12. Unplug the product from the wall outlet and refer servicing to qualified service personnel under the following conditions:
 - a. When the power-supply cord or plug is damaged or frayed.
 - b. If liquid has been spilled into the product.
 - c. If the product has been exposed to rain or water.
 - d. If the product does not operate normally by following the operating instructions. Adjust only those controls that are covered by the operating instructions, as an adjustment of other controls may result in damage and will often require extensive work by a qualified technician to restore the product to its normal operation.
 - e. If the product has been dropped or the cabinet has been damaged.
 - f. If the product exhibits a distinct change in performance.
 13. Avoid using a telephone (other than a cordless type) during an electrical storm. There may be a remote risk of electric shock from lightning.
 14. Do not use the telephone to report a gas leak in the vicinity of the leak.

SAVE THESE INSTRUCTIONS

BATTERY PRECAUTIONS

To reduce the risk of fire or injury to persons, read and follow these instructions.

1. Use only a 3.6V, 600MaH Ni-MH rechargeable battery in this unit.
2. Do not dispose of the battery in a fire, the cells may explode. Check with local codes for possible special disposal instructions.
3. Do not open or mutilate the battery as released electrolyte is corrosive and may cause damage to the eyes or skin. It may be toxic if swallowed.
4. Exercise care in handling the batteries in order not to short the battery with conducting material such as rings, bracelets and keys. The battery or conductors may overheat and cause burns.

IMPORTANT SAFETY PRECAUTIONS (CONTINUED)

FCC wants you to know

This equipment complied with part 68 of the FCC rules ACTA technical requirements. On the bottom of the base of this equipment is a label that contains, among other information, the FCC Registration Number and Ringer Equivalence Number (REN) for this equipment. You must, upon request, provide this information to your telephone company.

The USOC number of the registration jack for the equipment is RJ11C.

The FCC compliant telephone cord and modular plug is provided with this equipment. This equipment is designed to be connected to the telephone network or premises wiring using a compatible modular jack which is TIA/EIA-IS-968 compliant.

The REN is useful to determine the quantity of devices you may connect to your telephone line and still have all of those devices ring when your telephone number is called. In most, by not all areas, the sum of the RENs of all devices connected to one line should not exceed five (5.0). To be certain of the number of devices you may connect to your line, as determined by the REN, you should contact your local telephone company to determine the maximum REN for your calling area.

If your telephone equipment causes harm to the telephone network, the telephone company may discontinue your service temporarily. If possible, they will notify you in advance. But, if advance notice isn't practical, you will be notified as soon as possible. You will be informed of your right to file a complaint with the FCC.

Your telephone company may make changes in its facilities, equipment, operations or procedures that could affect the proper functioning of your equipment. If they do, you will be notified in advance to give you an opportunity to maintain uninterrupted telephone service. If you experience trouble with this telephone equipment, the telephone company may ask that you disconnect this equipment from the network until the problem has been corrected or until you are sure that the equipment is not malfunctioning.

This equipment cannot be used on telephone company provided coin service.

Connection to Party Line Service is subject to state tariffs.

This equipment is hearing aid compatible.

Warnings:

- Any changes or modifications not expressly approved by the party responsible for compliance could void the user's authority to operate the equipment.
- When your telephone is not in use, make sure the handset is engaged into the base unit.
- If it is determined that your telephone is malfunctioning, the FCC requires that it be disconnected from the modular outlet until the problem has been corrected.

NOTE: This equipment has been tested and found to comply with the limits for a Class B digital device, pursuant to Part 15 of the FCC Rules. These limits are designed to provide reasonable protection against harmful interference in a residential installation. This equipment generates, uses and can radiate radio frequency energy and, if not installed and used in accordance with the instructions, may cause harmful interference to radio communications.

IMPORTANT SAFETY PRECAUTIONS (CONTINUED)

However, there is no guarantee that interference will not occur in a particular installation. If this equipment does cause harmful interference to radio or television reception which can be determined by turning the equipment off and on, the user is encouraged to try to correct the interference by one or more of the following measures:

- Reorient or relocate the receiving antenna.
 - Increase the separation between the equipment and receiver.
 - Connect the equipment into an outlet on a circuit different from that to which the receiver is needed.
 - Consult the dealer or an experienced radio/TV technician for help.
1. If your local telephone exchange only accepts Pulse dialing, you may have to switch the Tone/Pulse switch to Tone to access certain services that require Tone signalling (such as home banking). After the initial line is connected to the number you are calling, switch the Tone/Pulse switch to Tone to access Tone signalling. When you have completed your call, switch the Tone/Pulse switch back to Pulse.
 2. Hearing aid compatibility - Your telephone is compatible for use with hearing aids.
 3. If there is a problem with this unit, the telephone company may ask you to disconnect this equipment from the network until the problem has been corrected or you are sure that the equipment is not malfunctioning.

WELCOME

Welcome to the world of Hello Kitty

My friends at Emerson Radio Corp. are producing this Hello Kitty Caller ID* Cordless Telephone, under license from Sanrio Company Ltd. We have taken great care to make sure your telephone was in perfect working order when it left our factory. It has been designed to give you many years of enjoyment and trouble free operation. Read this manual before operating this unit to become familiar with its features. In the event you require technical assistance, please contact my friends at the Emerson Radio Consumer Affairs Department at 1-800-898-9020. Retain this manual for future reference.

In the space provided, record the serial number.

Model: HK250

Serial Number _____

* You must subscribe to caller ID service from your local telephone company to receive caller identification.

LOCATION OF CONTROLS AND INDICATORS

HANDSET

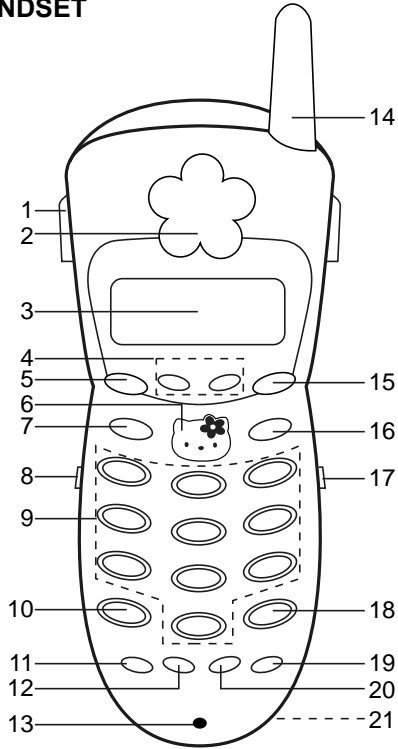

BASE

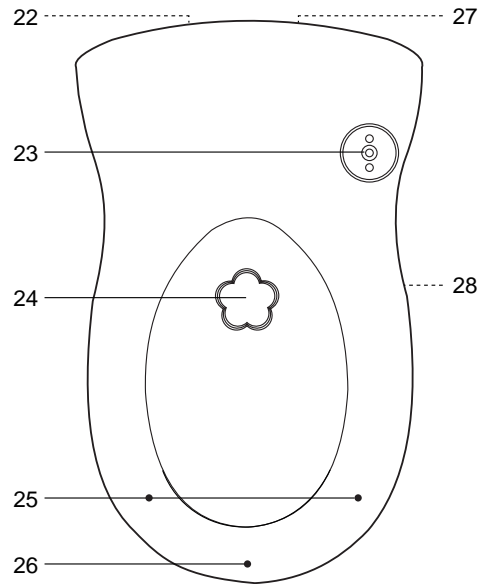

HANDSET:

1. Belt Clip
2. Earpiece
3. Display
4. REVIEW/VOLUME ▲/▼ Buttons
5. CID Button
6. TALK Button
7. ERASE Button
8. RINGER ON/OFF Switch
9. Key Buttons (0-9)
10. */TONE/◀ Button
11. FLASH Button
12. MEMO (Memory) Button
13. Microphone
14. Antenna
15. PROG (Program) Button

16. CHN (Channel) Button

17. Headset Jack
18. #/▶ Button
19. REDIAL Button
20. PAUSE Button
21. Battery Compartment (Rear of Unit)

BASE:

22. TEL LINE Jack (Rear of Base)
23. Hello Kitty Figure
24. PAGE Button
25. IN USE/Incoming Call Indicator
26. CHARGE Indicator
27. DC IN Jack (Rear of Base)
28. TONE/PULSE Switch

LOCATION OF CONTROLS AND INDICATORS (CONTINUED)

DISPLAY

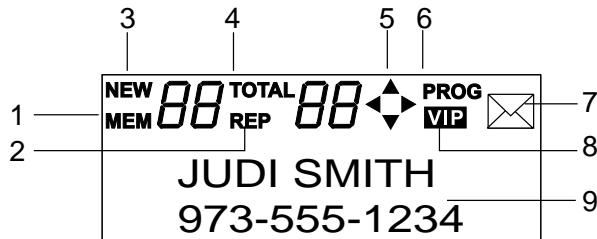

1. MEM (Memory) Indicator - Indicates the unit is in Memory Dial Programming mode or Memory Dialing mode.
2. REP (Repeat) Indicator - Indicates how many phone calls have been made from the same telephone number.
3. NEW Indicator - Indicates the number of new caller ID data items that have not been reviewed.
4. TOTAL Indicator - Indicates the total number of stored ID data items.
5. Arrow Indicators - Indicates which arrow button can be used.
6. PROG (Program) Indicator - Indicates the unit is in Programming mode.
7. Message (“”) Indicator - Indicates that mailbox in the central office has a message. If you have subscribed to Voice Mail message service and you have requested Visual Message Indication from your phone company, “” will appear on the LCD screen when in the Standby mode.
8. VIP Indicator - Indicates that priority ringer has been set for the displayed number.
9. Name/Number Indicator - Name and number of incoming call.

LCD BACK LIGHT

The LCD is back lit under the following conditions:

1. While receiving an incoming call (during ringing).
2. For 10 seconds, when the handset is picked up from the cradle.
3. For 10 seconds, when any button is pressed in the Programming mode, Caller ID Review mode or Stored Number Review mode.
4. For 10 seconds, when any button is pressed in any mode other than those listed above.

The LCD back light will go off 10 seconds after the Talk mode is terminated by pressing the TALK button or immediately after the handset is placed in the base.

INSTALLATION INSTRUCTIONS

1. Carefully unpack and remove your unit from the box.
2. Make sure all of the following items have been included:
 - Base Unit
 - Handset Unit
 - Rechargeable Ni-MH Battery Pack (3.6V, 600mAH)
 - AC Adapter (AC120V, 60Hz/DC9V, 300mA)
 - Telephone Cord
 - Memory Label
3. Make sure the Rechargeable Battery is installed or install the Rechargeable Battery as described on the next page.

PLEASE REFER TO THE FOLLOWING DIAGRAM FOR STEPS 4 THROUGH 7:

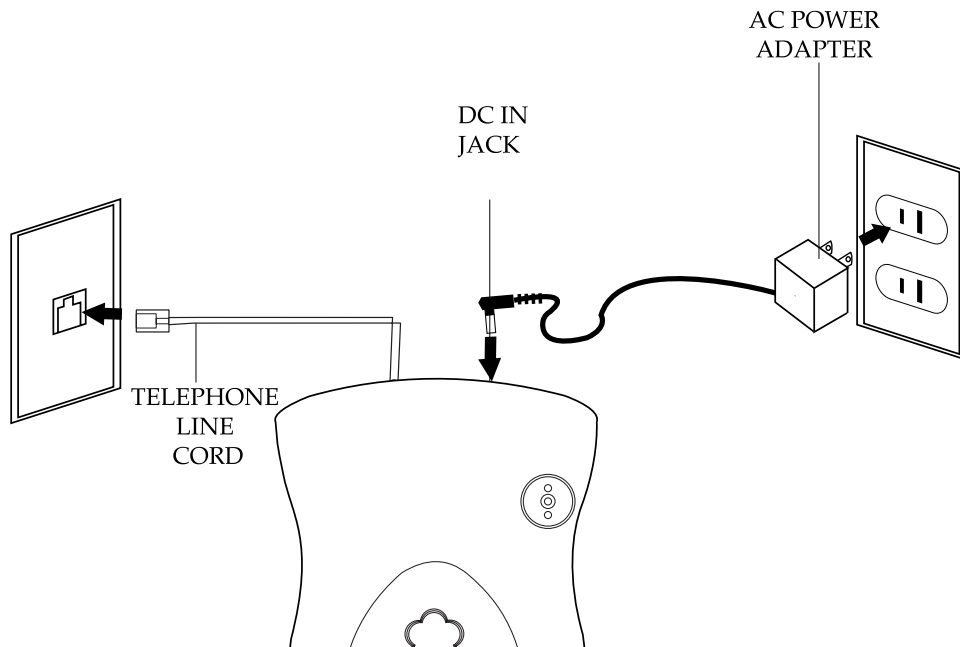

4. Slide the TONE/PULSE switch on the side of the Base unit to TONE or PULSE to match the service provided on your telephone line. If you are not sure of your service, please contact your telephone company. The factory preset position for this switch is TONE.
5. Connect one end of the telephone line cord into the TEL LINE jack on the rear of the base unit and the other end into a modular telephone jack.
6. Insert the small plug at the end of the AC adapter into the DC IN jack located at the rear of the base unit.

NOTE: Use only the AC adapter provided with your unit.

7. Plug the AC adapter into a standard 120V AC wall outlet.

INSTALLATION INSTRUCTIONS (CONTINUED)

Installation of the Rechargeable Battery

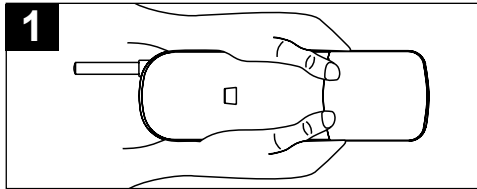

1 Remove the battery cover located on the rear of the handset by pressing on the top cover and sliding it downward.

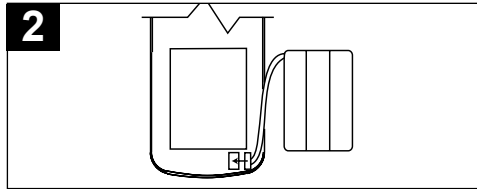

2 Plug the new battery into the rechargeable battery plug and insert the rechargeable battery into the battery compartment.

NOTE: The plug will fit only one way. If you have difficulty, be sure the plug and socket are aligned properly.

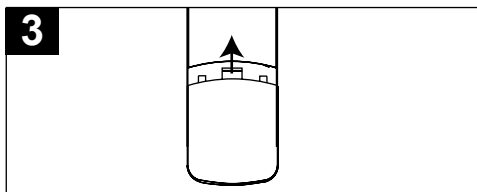

3 Put the battery cover back on by sliding it upward until it clicks into place.

Charging the Rechargeable Battery

Be sure the rechargeable battery be fully charged 12 hours prior to initial use. The handset's rechargeable battery will be charged when it's on the base's charge contacts; the CHARGE indicator will light when it is placed in the base.

NOTES:

- LOW BATTERY will appear in the display and the handset will beep every 30 seconds when the battery power is low and needs recharging. If the battery becomes weak while you are on a call, the TALK indicator will blink and the handset will beep once; end the call immediately and return to the base for recharging.
- Every few months, or when charging becomes abnormal, clean the contacts of the handset and the base with a standard pencil eraser.
- To maximize battery life, fully discharge the battery every month or two. To do this, simply unplug the telephone line cord and press the TALK button until the battery is discharged, and then recharge it.

SET-UP INSTRUCTIONS

SETTING THE LANGUAGE

Set the language (ENGLISH, SPANISH, FRENCH) as follows:

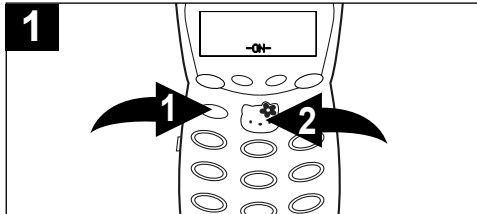

Press and hold the ERASE button ❶ for more than two seconds or press the TALK button ❷ twice to clear any displayed number and return to the Standby mode.

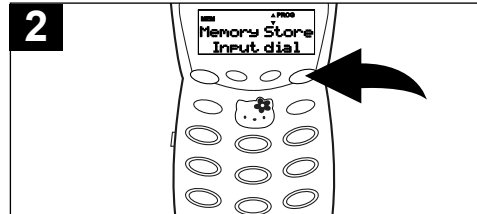

While in the Standby mode, press the PROG button.

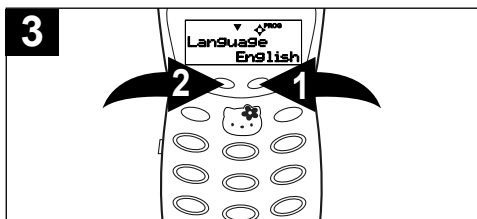

Press the REVIEW/VOLUME ▲ button ❶ once or the REVIEW/VOLUME ▼ button ❷ three times to enter the Language menu.

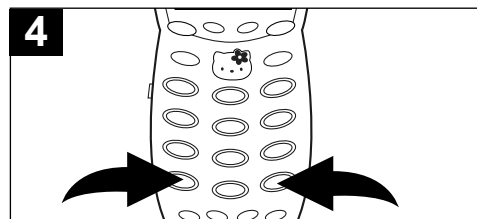

Press the ◀ or ▶ button ❶ to select the desired language (ENGLISH, SPANISH, FRENCH).

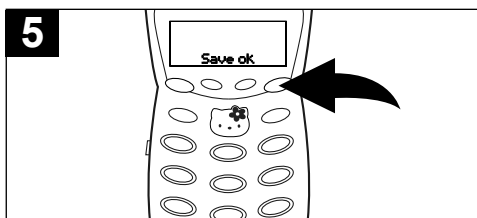

Press the PROG button again to store the language; "Save ok" will appear in the display for three seconds and a confirmation tone will be heard.

SET-UP INSTRUCTIONS (CONTINUED)

SETTING THE AREA CODE

In order for the Caller ID redial feature to work properly, you must set the phone to your local area code as described below. If you live in a town with more than one area code, do not enter an area code for this option.

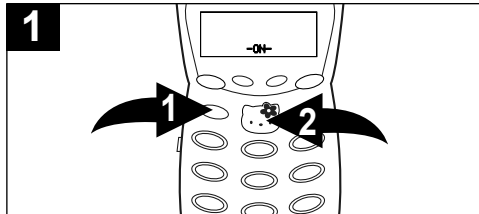

Press and hold the ERASE button ❶ for more than two seconds or press the TALK button ❷ twice to clear any displayed number and return to the Standby mode.

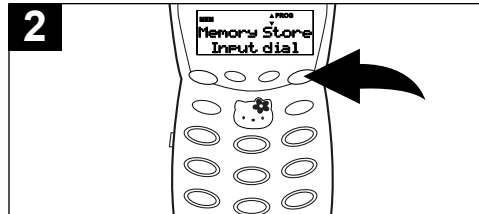

While in the Standby mode, press the PROG button.

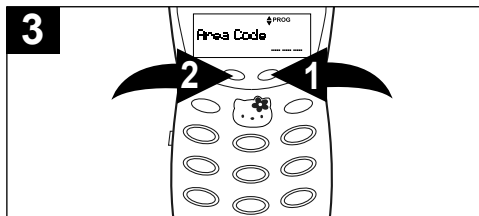

Press the REVIEW/VOLUME ▲ button ❶ twice or the REVIEW/VOLUME ▼ button ❷ twice to enter the Area Code menu.

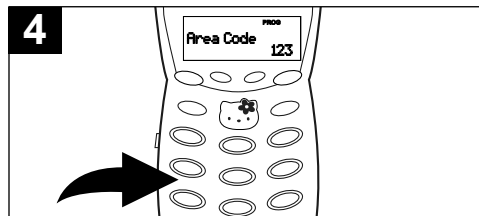

Use the Key buttons to enter in the area code.



Press the PROG button again to store the area code; "Save ok" will appear in the display for three seconds and a confirmation tone will be heard.

SET-UP INSTRUCTIONS (CONTINUED)

SETTING THE LCD CONTRAST

If you find the LCD screen difficult to read, set the contrast level as follows:

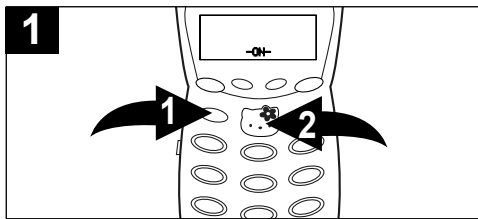

Press and hold the ERASE button ❶ for more than two seconds or press the TALK button ❷ twice to clear any displayed number and return to the Standby mode.

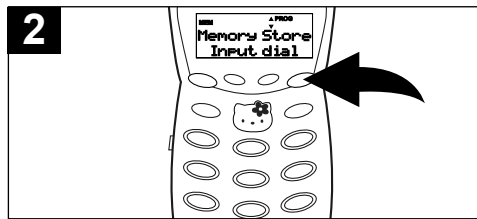

While in the Standby mode, press the PROG button.

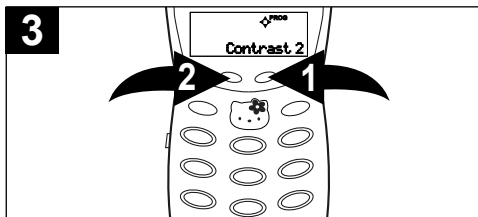

Press the REVIEW/VOLUME ▲ button ❶ three times or the REVIEW/VOLUME ▼ button ❷ once to enter the Contrast menu.

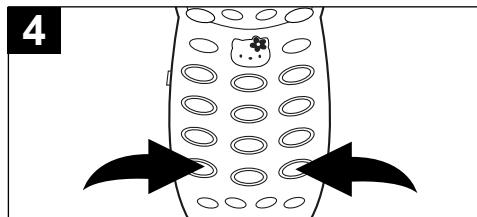

Press the ◀ or ▶ button to select one of the three contrast levels (3 being the darkest, 1 being the lightest).



Press the PROG button again to store the contrast level; "Save ok" will appear in the display for three seconds and a confirmation tone will be heard.

BASIC OPERATION

RINGER SWITCH

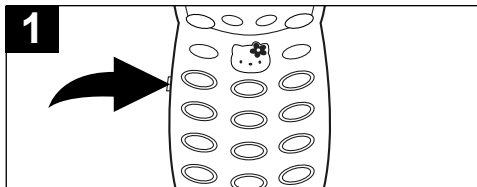

Slide the RINGER ON/OFF switch on the side of the handset to the ON position to turn the ringer on. Slide the RINGER switch to the OFF position to turn the ringer off.

STONE/PULSE SWITCH

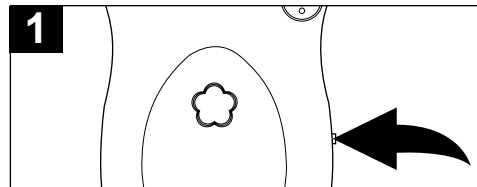

Slide the TONE/PULSE switch on the side of the base to TONE or PULSE to match the service provided on your telephone line. If you are not sure of your service, please contact your telephone company.

AUTO TALK AND AUTO STANDBY

The Auto Talk feature will allow you to answer a call by simply removing it from the base, there is no need to press the TALK button.

The Auto Standby feature allows you to hang up the phone by simply returning it to the base.

CONNECTING THE HEADSET

For hands-free conversation, a headset (not included) can be connected to the 2.5mm headset jack on the side of the handset unit. The handset receiver and microphone are disabled when a headset is connected. When the headset is connected, press the TALK button to answer or place a call. Refer to the headset manufacturer's manual for more details.

PLACING A CALL

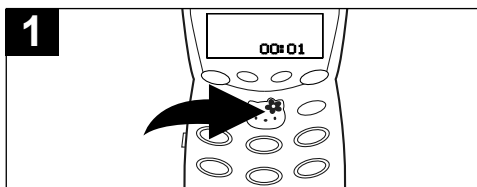

After the battery has been fully charged, press the TALK button and listen for a dial tone; the timer will appear in the display.

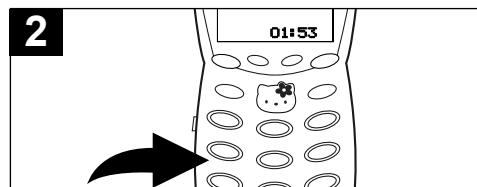

Press the Key buttons (0-9) to dial the phone number you wish to call. Ten seconds after dialing, the display will show the amount of time you have been on the phone.

BASIC OPERATION (CONTINUED)

RECEIVING A CALL

The last 99 incoming calls are saved in the Caller ID log.

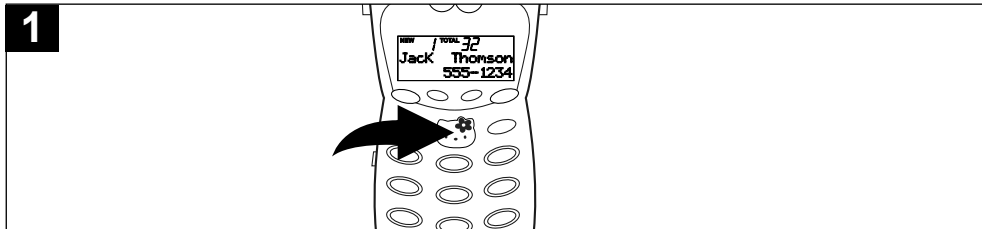

Make sure that the Caller ID service is turned on by your phone company. When you receive a call, the display will show the name of the caller and number of the call. To answer the call if the handset is out of the base, press the TALK button. If the handset is in the base, simply remove it from the base. The display will show the amount of time you have been on the phone.

NOTES:

- The incoming call indicator will blink on the base unit, even if the RINGER switch is off and a call is received.
- If you subscribe to Caller ID, the time and date are automatically set when the first call is received.
- If a call is received from an area which does not provide caller ID service, the display will show, "UNKNOWN". If a call is received from outside the Caller ID area, the display will show, "OUT OF AREA".
- If a call is received from a caller that has blocked his/her information, the display will show, "PRIVATE CALL".
- Calls picked up on the first ring will not be logged in the Caller ID log.
- Call Waiting calls are shown in the Caller ID log if you subscribe to the extra feature from the phone company that allows this.
- If there are new calls, "NEW" will blink in the display.
- If a call is received from the same number more than once since the last records were reviewed, no new entry is made, but the repeat (REP) indicator and the number of repeat calls is displayed.

BASIC OPERATION (CONTINUED)

REDIALING A NUMBER

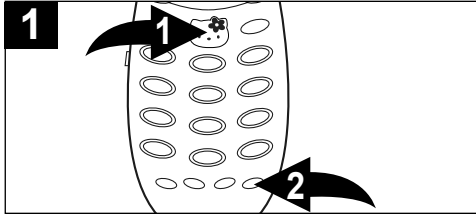

Press the TALK button ❶ (the light will come on), followed by the REDIAL button ❷ to automatically redial the last number dialed on this handset (up to 32 digits).

NOTE: Please note that only the last number you called on this handset can be stored in the Redial memory.

CHANNEL SELECTION

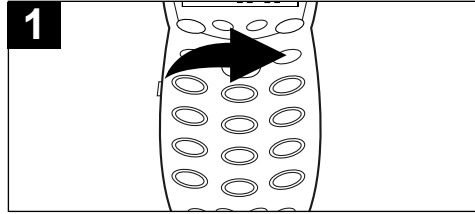

The base unit will automatically search for the clearest channel in the Standby mode. However, should you hear static or noise during the course of a conversation which makes it difficult to hear the caller, the CHN (Channel) button on the handset allows you to choose between 40 preset channels.

NOTE: The TALK LED will flash and the unit will sound two beeps to indicate the unit is changing to another channel. The unit will sound an error beep and return to the original channel if it cannot reach a clearer channel.

ENDING A CALL

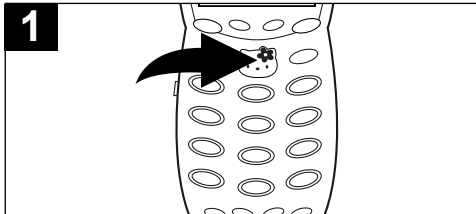

To end a call, simply return the handset to the base, or press the TALK button on the handset; the light will go off.

ADJUSTING EARPIECE VOLUME

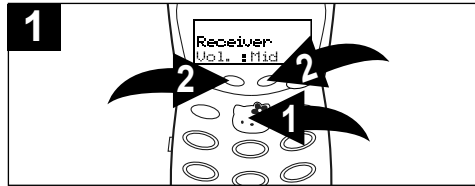

To adjust the volume in the earpiece, press the TALK button ❶ and the light will come on. Then, press the REVIEW/VOLUME ▲/▼ buttons ❷ until the desired volume level is reached.

OUT OF RANGE WARNING

The handset and base communicate up to a maximum range. The distance can be affected by the weather, power lines or other cordless telephones. You are out of range and should move closer when:

- You hear noise or static.
- Pressing the TALK button generates three short beeps.
- Pressing the CID button when a number is displayed generates three short beeps.
- You cannot receive an incoming call.

BASIC OPERATION (CONTINUED)

USING THE TONE BUTTON

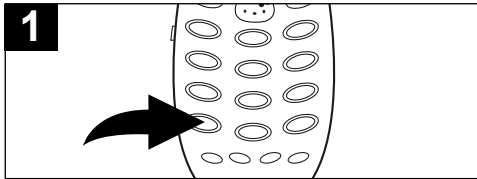

If you are in a Pulse dialing area you may still take advantage of touch-tone services after dialing to respond to touch-tone prompts. To do this, press the ***TONE/◀** button to temporarily change the dialing mode from Pulse to Tone after dialing in the Pulse mode. This will enable Pulse users to access touch-tone services. It will revert back to Pulse after hanging up.

CALL WAITING

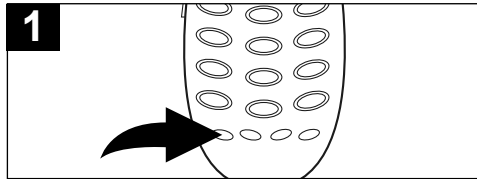

If you subscribe to Call Waiting through your local phone company, and you receive another phone call, the phone will alert you with a beep and the display will show the name and number. Simply press the **FLASH** button to answer the new call. Press the **FLASH** button again to return to the original call. Call Waiting Caller ID also needs to be subscribed to in order to see the new caller's name/number on the display if you are already on the phone.

PAGING THE HANDSET

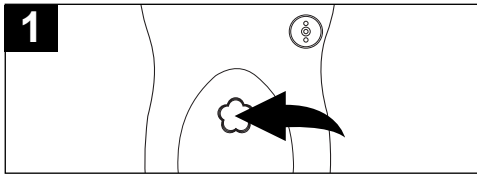

Press the **PAGE** button on the base to locate the handset when not in use; the handset will ring with three short beeps and the **TALK** button will blink. "Page" will appear in the display on the LCD during paging.

FINDING THE HANDSET

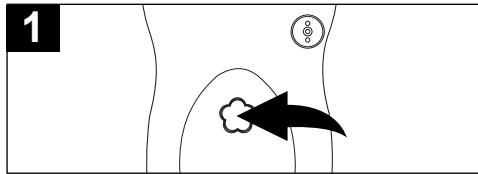

Press and hold the **PAGE** button on the base for more than three seconds to locate the handset when not in use; the handset will ring for 30 seconds repeating sequences of three short beeps. Press the **TALK** button to end the page function.

NOTE:

When an incoming call is received while paging and the **RINGER** switch is set to the **ON** position, the Page mode will be terminated and the incoming ringer will start.

BASIC OPERATION (CONTINUED)

MESSAGE WAITING FUNCTION

When a caller has recorded a message on a personal message service, “” will appear in the display and will disappear when you retrieve your message. This feature is only for subscribers of a voice mail message waiting service.

DIGITAL SECURITY SYSTEM

The security code prevents your cordless telephone conversation from being accessed by a phone on a different line. Once the handset battery is fully charged, the handset will automatically select the code from a total of over 65,000 combinations. The code is changed every time the handset is placed in the cradle.

If you experience difficulty with placing or receiving calls, a lost security code may be the cause of the problem. When this occurs, the handset can no longer communicate with the base. Reset by placing the handset on the base for 5-10 seconds. If that does not work, unplug the AC adaptor from the wall outlet. Disconnect the handset battery for 5-10 seconds, then reconnect. Place the handset back on the base and then replug the AC adaptor.

BASIC OPERATION (CONTINUED)

CHECKING THE CALLER ID LOG

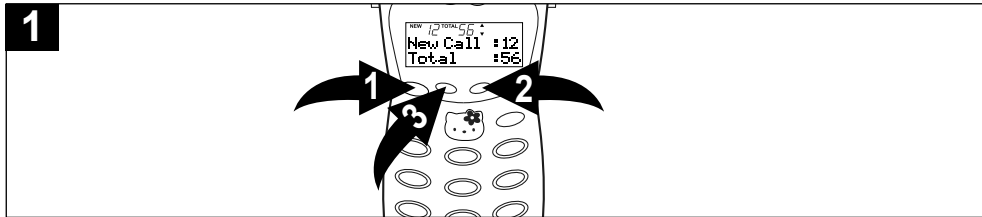

To scroll through the calls, press the CID button ❶; the New Calls and the Total Calls will appear in the display. Press the REVIEW/VOLUME ▲ button ❷ to go through the calls from the first call received to the last. Press the REVIEW/VOLUME ▼ button ❸ to go through the calls from the last call received to the first. Press the CID button ❶ again when done.

NOTES:

- The NEW indicator will blink until all new caller ID information has been reviewed.
- The REP indicator will appear in the display if you have received multiple new calls from the same number.

VIEWING LONG TELEPHONE NUMBERS/NAMES AND CHECKING THE DATE AND TIME

Due to display size limitations, a telephone number longer than 10 digits or a name more than 12 characters long cannot be viewed at one time. For the same reason, the received date and time cannot be displayed with the name and number. View long names/numbers as follows:

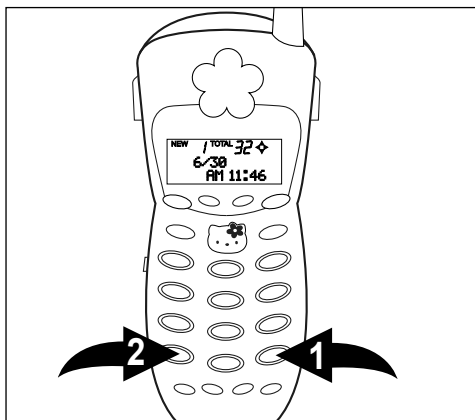

Press the ► button ❶ once or the ◀ button ❷ three times to display the full number of the call received.

Press the ► button ❶ twice or the ◀ button ❷ twice to display the full name of the call received.

Press the ► button ❶ three times or the ◀ button ❷ once to display the date and time of the call received.

BASIC OPERATION (CONTINUED)

DELETING ONE NAME/NUMBER FROM THE CALLER ID LOG

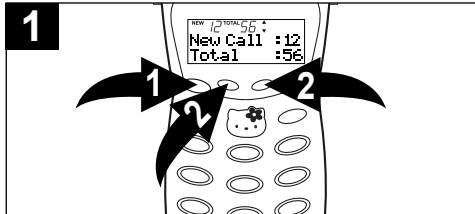

Scroll through the calls to select a number to delete by pressing the CID button ❶ and then scroll by pressing the REVIEW/VOLUME ▲/▼ buttons ❷.

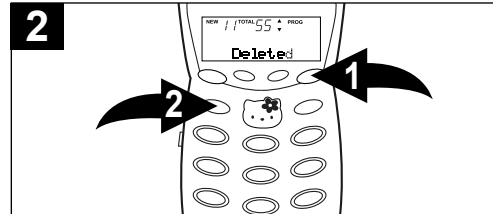

Press the PROG button ❶ then press the ERASE button ❷; "DELETED" will appear in the display and a confirmation tone will be heard.

DELETING ALL NAME(S)/NUMBER(S) FROM THE CALLER ID LOG

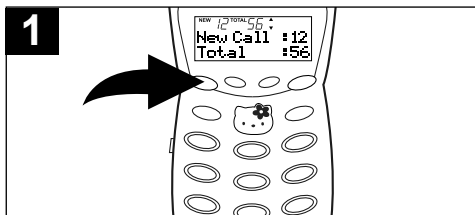

Press the CID button.

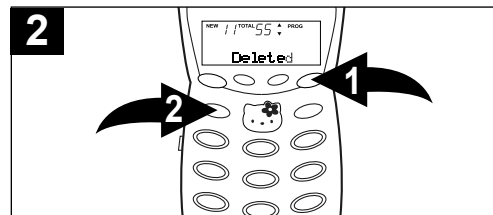

Press the PROG button ❶ then press the ERASE button ❷; "DELETED" will appear in the display and a confirmation tone will be heard.

DIALING A NUMBER IN THE CALLER ID DISPLAY

You can automatically call a number from the caller ID log as follows:



Scroll through the calls to select a number to dial by pressing the CID button ❶ and then scroll by pressing the REVIEW/VOLUME ▲/▼ buttons ❷.

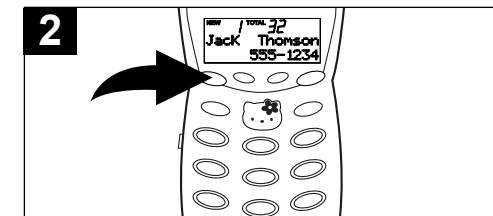

Press the CID button again to dial the number.

BASIC OPERATION (CONTINUED)

EDITING TELEPHONE NUMBERS

You can edit a phone number in the caller ID as follows:



Scroll through the calls to select a number to edit by pressing the CID button ❶ and then scroll by pressing the REVIEW/VOLUME ▲/▼ buttons ❷.

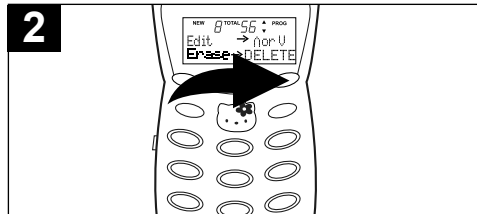

Press the PROG button to select the menu.

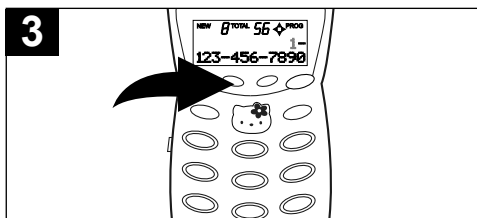

Press the REVIEW/VOLUME ▼ button to go to the number; the first "1" will start blinking.

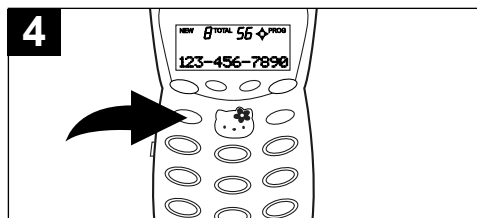

Press the ERASE button; the "1" will be deleted and the second digit will start blinking. Press a desired number to insert and it will be inserted before the first digit.

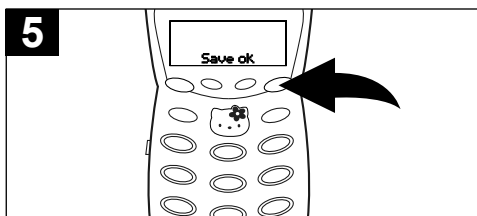

Press the PROG button again to store the new number; "Save ok" will appear in the display for three seconds and a confirmation tone will be heard.

BASIC OPERATION (CONTINUED)

EDITING CALLER NAMES

You can edit a name in the caller ID as follows:



Scroll through the calls to select a name to edit by pressing the CID button ❶ and then scroll by pressing the REVIEW/VOLUME ▲/▼ buttons ❷.

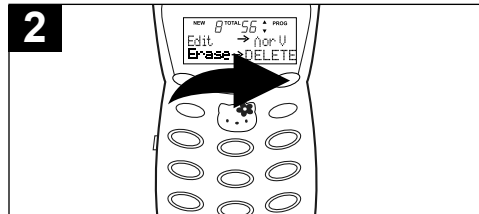

Press the PROG button to select the menu.

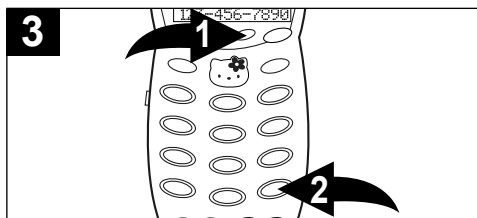

Press the REVIEW/VOLUME ▲ button ❶ to start character editing. Press the ► button ❷ repeatedly to move the cursor to the desired character to edit.

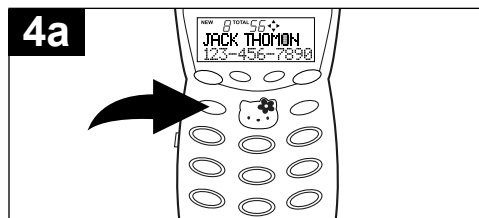

TO ERASE THE CHARACTER: Press the ERASE button; the next character will move one step to the left. Press a desired letter to insert and it will be inserted before the first character.

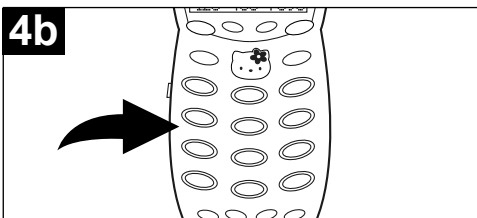

TO CHANGE THE CHARACTER: Press the key button to change to a different character (see chart on page 22).



Press the PROG button again to store the new name; "Save ok" will appear in the display for three seconds and a confirmation tone will be heard.

BASIC OPERATION (CONTINUED)

STORING NAMES AND TELEPHONE NUMBERS

The memory can store up to 20 name/telephone numbers.

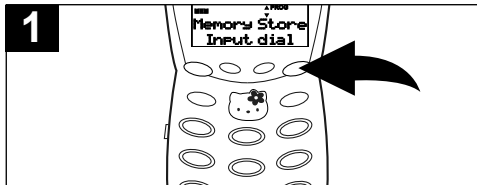

Press the PROG button while in the Standby mode.

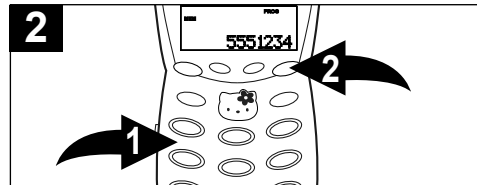

Using the Key buttons (0-9, *, #) ❶, enter the telephone number, then press the PROG button ❷ again.

NOTES:

- If a 17th digit is entered, the Store mode will be terminated with an error tone.
- If you misdial, press the ERASE button to clear the last digit.
- If desired, a pause can be inserted between digits by using the PAUSE button. When a pause is entered, "P" will be displayed.

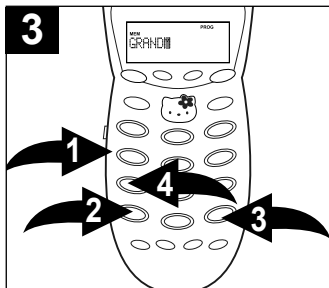

See the Character Map Chart on the top of the next page and using the Key buttons (0-9, *, #) ❶, enter the name. Press the ◀ ❷ or ▶ ❸ button to move the cursor to the right or the left after entering each character. For example, press the 4 button ❶ once to enter a "G", then press the ▶ button ❸. Press the 7 button ❹ three times to enter the second character, "R". Repeat this step until all letters have been entered (up to 16).

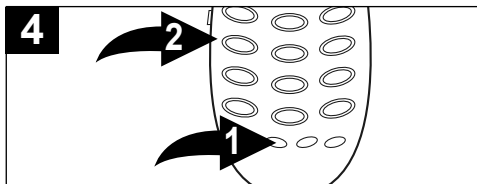

Press the MEMO button ❶. Enter two digits (01-20) using the Key buttons ❷ to assign the desired memory location to store the data. "0" must be added for memory locations 1 - 9.



One second after step 4, "Save ok" will appear in the display for three seconds and a confirmation tone will be heard.

NOTES:

- If the data is stored in a location where data has already been stored, the old data will be overwritten.

BASIC OPERATION (CONTINUED)

CHARACTER MAP CHART

Key	1 press	2 press	3 press	4 press	5 press	6 press	7 press	8 press
1	-	.	,	1	-	.	,	1
2	A	B	C	2	A	B	C	2
3	D	E	F	3	D	E	F	3
4	G	H	I	4	G	H	I	4
5	J	K	L	5	J	K	L	5
6	M	N	O	6	M	N	O	6
7	P	Q	R	7	P	Q	R	7
8	T	U	V	8	T	U	V	8
9	W	X	Y	9	W	X	Y	9
0	Space	0	Null	0	Null	Space	0	Null

SAVING CALLER ID INFORMATION TO THE MEMORY

The memory can save the information directly from the caller ID.

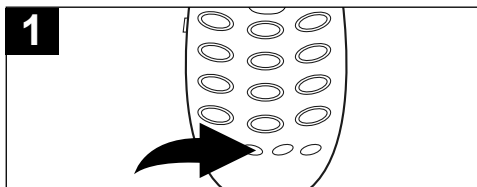

1
Scroll through the calls to select a number as previously described on page 21. Press the MEMO button.

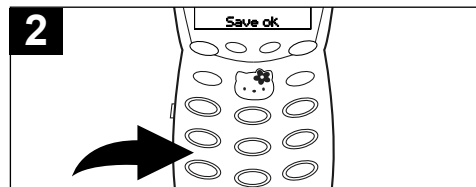

2
Enter two digits (01-20) using the key buttons to assign the desired memory location to store the data. One second after completing this step, "Save ok" will appear in the display.

DIALING A NUMBER FROM THE MEMORY

To select and dial a number from the memory, follow the steps below:

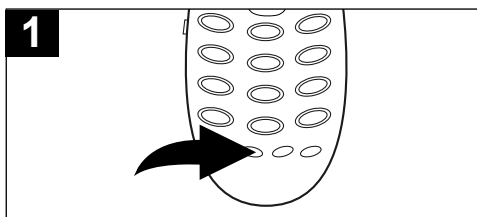

1
Press the MEMO button while in the Standby mode.

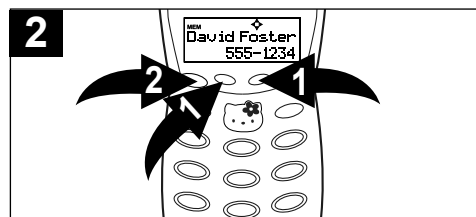

2
Press the key buttons to enter the memory location or the REVIEW/ VOLUME ▲/▼ buttons 1 to locate the number you would like to call, then press the CID button 2. The phone number will automatically be dialed.

BASIC OPERATION (CONTINUED)

DELETING A NUMBER FROM THE MEMORY

Delete a number from the memory as follows:

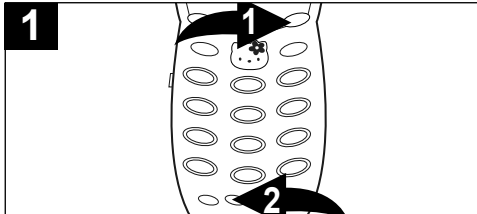

Press the PROG button ❶ while in the Standby mode, followed by the MEMO button ❷.

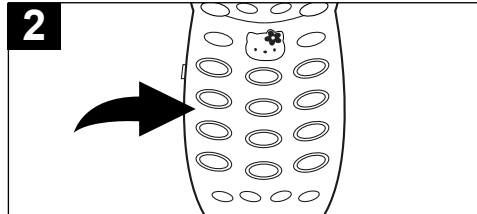

Enter the two digits (01-20) of the memory location you want to delete. One second after completing this step, "Deleted" will appear in the display for three seconds and a confirmation tone will be heard.

PREFERRED CALLS (VIP)

This function allows you to recognize an incoming caller from the ringing sound by assigning a priority VIP ring to the designated number from the memory as follows:

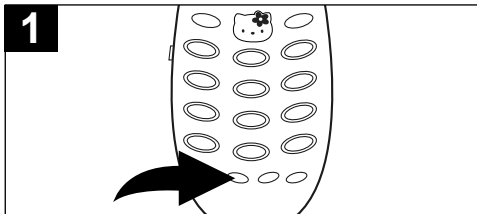

Press the MEMO button while in the Standby mode.

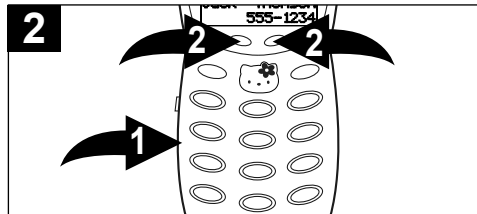

Press the key buttons ❶ to enter the memory location or the REVIEW/ VOLUME ▲/▼ buttons ❷ to locate the number you would like to assign a priority VIP ringer to.

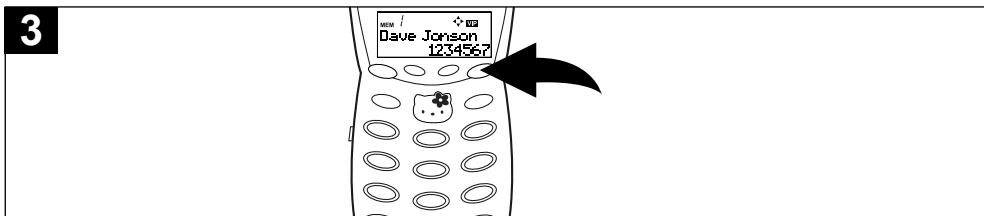

When finished, press the PROG button. The VIP indicator in the display will light and the handset will beep. 25 seconds after pressing the PROG button, the display will clear, a beep will sound and the unit will return to the Standby mode.

TROUBLESHOOTING GUIDE

SYMPTOM	SOLUTION
No dial tone.	<ul style="list-style-type: none"> • Make sure the telephone line cord is connected properly to the modular wall jack.
No power on the handset.	<ul style="list-style-type: none"> • Make sure the battery pack is properly connected inside the handset. • The handset may need recharging; recharge handset.
Handset does not charge.	<ul style="list-style-type: none"> • Make sure the charging contacts on both the base and handset are in contact during charging.
	<ul style="list-style-type: none"> • The charging contacts may be dirty; clean with alcohol-moistened cloth.
	<ul style="list-style-type: none"> • The battery may need to be replaced.
Range is limited.	<ul style="list-style-type: none"> • Move the base so it is centrally located in your residence and make sure the base is not located near an appliance.
Call received flutters or fades.	<ul style="list-style-type: none"> • The handset may need recharging; recharge handset.
Cannot hear ringer.	<ul style="list-style-type: none"> • Make sure the telephone line cord is connected properly to the modular wall jack.
	<ul style="list-style-type: none"> • Make sure RINGER ON/OFF switch is set to the ON position.
Caller ID information does not appear.	<ul style="list-style-type: none"> • You must subscribe to Caller ID service.
	<ul style="list-style-type: none"> • You must let the phone ring twice before answering.
Time does not automatically set.	<ul style="list-style-type: none"> • If you subscribe to Caller ID service, the time and date will automatically set during the first call.

If there was a power failure or if the unit was unplugged, replace the handset to the base for two to five seconds to reset the system.

CARE AND MAINTENANCE

1. Clean your phone with a damp (never wet) cloth. Solvent or detergent should never be used.
2. Avoid operating your unit under direct sunlight or in hot, humid or dusty places.
3. Keep your unit away from heating appliances.



TO FIND THE LOCATION AND
PHONE NUMBER OF YOUR
NEAREST AUTHORIZED
SERVICE CENTER...

CALL TOLL FREE: 1-800-695-0098

FOR ADDITIONAL SET-UP OR OPERATING ASSISTANCE
PLEASE CALL:
1-800-898-9020

FOR CUSTOMER SERVICE, PLEASE WRITE TO:
Emerson Radio Corp.
Consumer Affairs Dept.
1901 Diplomat Drive
Farmers Branch, TX 75234

LIMITED WARRANTY

Emerson Radio Corp. warrants manufacturing defects in original material, including original parts and workmanship, under normal use and conditions, for a period of one year from the date of original purchase in the U.S. With your dated proof of purchase, we will provide repair service at no charge for labor and parts at an authorized Depot Repair Facility, or replace the product in our discretion. For repair or replacement, pack your unit in a padded box, enclose your check or money order payable to Emerson Radio Corp. in the amount of \$9.00 (not required by California residents) to cover shipping and handling costs, and enclose a copy of your proof of purchase. Send your unit to:

Emerson Radio Corp.
1901 Diplomat Drive
Farmers Branch, TX 75234

This warranty does not cover damage from negligence, misuse, abuse, accident, failure to follow operating instructions, commercial use, rental, repairs by an unauthorized facility, or products purchased, used, serviced or damaged outside of the United States.

THIS WARRANTY GIVES YOU SPECIFIC LEGAL RIGHTS, AND YOU MAY ALSO HAVE OTHER RIGHTS WHICH VARY FROM STATE TO STATE.

AU898N



EMERSON
PART NO.: 21-2041
209-01

Printed in China



***CORDLESS TELEPHONE
WITH CALLER ID AND 20
MEMORY DIALING***

***OWNER'S MANUAL
HK250***