

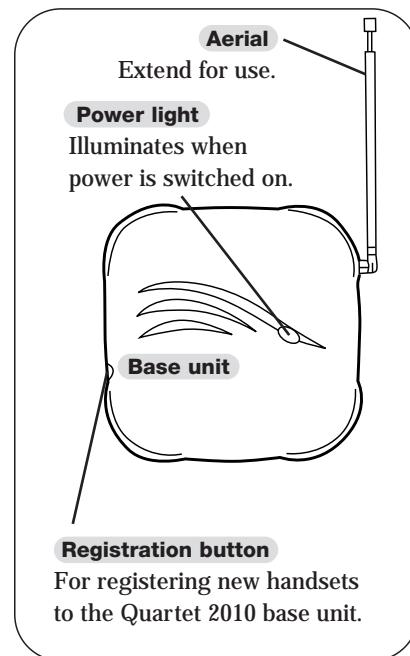

**Please open this page for an 'at a glance'
guide to your Quartet 2010.**

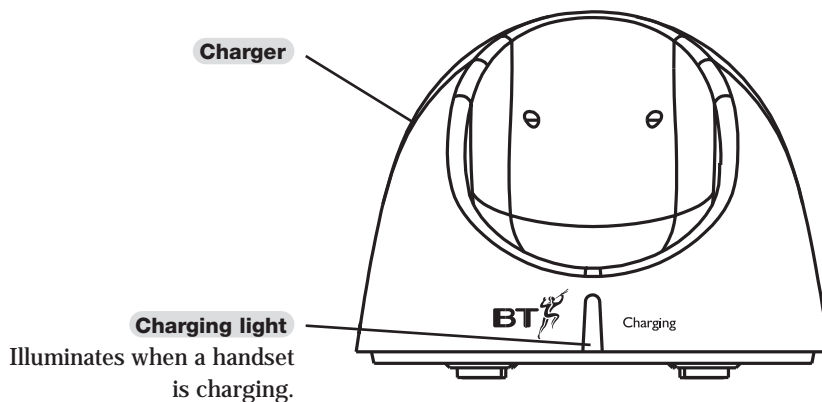

At a glance

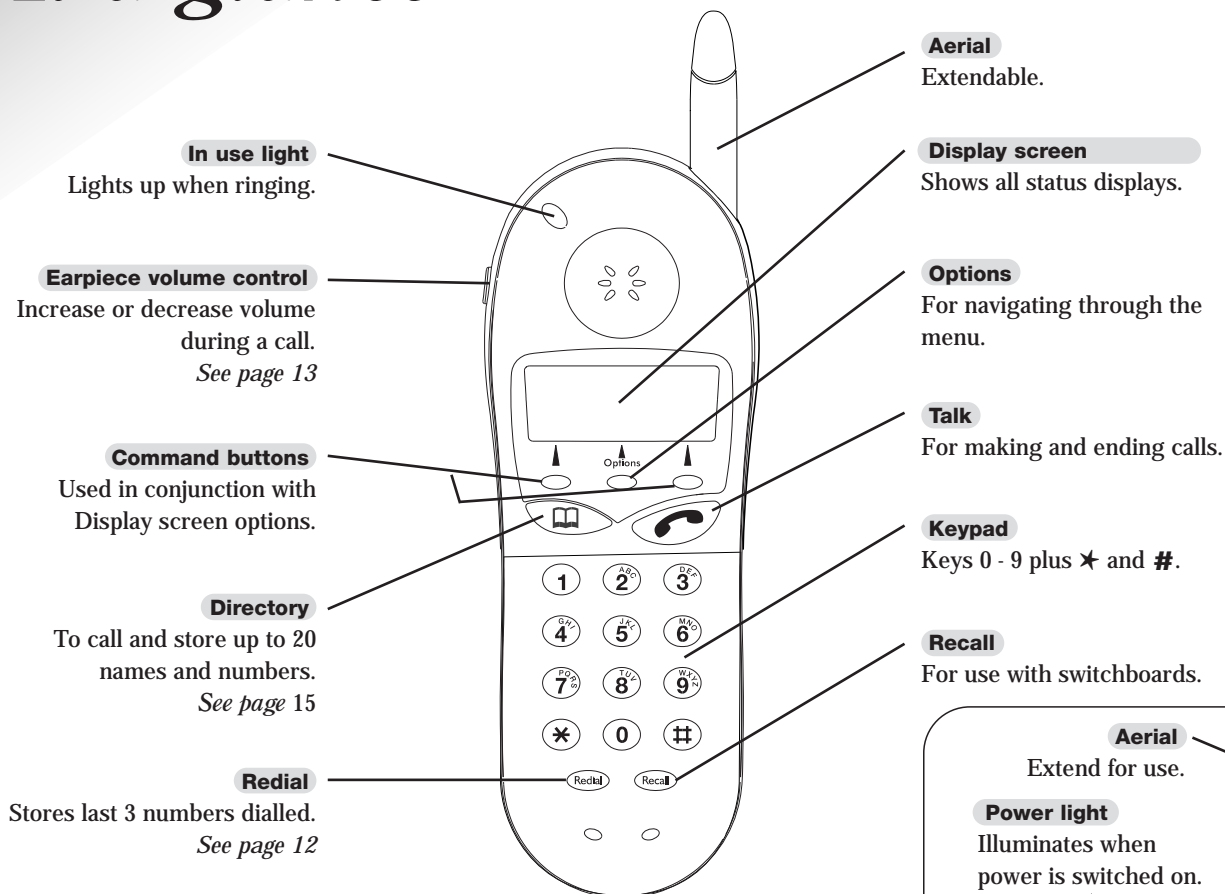

In this guide

<i>At a glance</i>	1
<i>Introduction</i>	4
<i>Setting up</i>	6
<i>Using your Quartet 2010</i>	8
<i>Making and receiving calls</i>	11
<i>Using the directory</i>	15
<i>Optional settings</i>	18
<i>Using Select Services</i>	21
<i>Using additional handsets</i>	30
<i>Wall mounting</i>	32
<i>Help and advice</i>	34
<i>Technical advice</i>	36
<i>Index</i>	38
<i>Wall mounting template</i>	39

Introduction

Your BT Quartet 2010 cordless telephone is designed for ease of use and is made to BT's high standards.

The BT Quartet 2010 combines the advantages of cordless operation with the performance of a high quality telephone. It offers unparalleled quality and features.

Cordless telephone functions

Your Quartet 2010 offers you the convenience and flexibility of a cordless telephone system and has been specifically designed to be easy to use. You can use up to 4 handsets with the base unit and transfer calls between them. The handset is highly functional and has a clear and simple display to assist you to use the many helpful features of your telephone, and BT Select Services.

Directory

The Directory, which you access via the directory button, allows you to store up to 20 names and numbers in alphabetical order. You can scroll through and edit or delete them. You can also preview entries and set up calls directly from them.

Select Services

Your Quartet 2010 is designed to make it easy for you to access and manage BT's Friends & Family and certain BT Select Services. For instance, you may also want to change the time for your Reminder Call or switch Call Waiting on or off.

These can all be edited, enabled or cancelled via the handset display.

Handset functions

Apart from some very basic functions on the base unit and charger, your Quartet 2010 is managed almost entirely from the handset. Using the handset's display screen and buttons, you can edit and activate the functions of your Quartet 2010, both on and off-line. The main method of control, is via a tree of *menus*, which you can access and navigate through by using buttons beneath the display. Please see 'Menu options', page 8.

Unpacking your Quartet 2010

Check that your BT Quartet 2010 is complete.
When you unpack it, you should have:

-
- BT Quartet 2010 base unit with telephone line cable attached.
-

- Cordless handset
-

- Charger
-

- 2 x 13 amp mains power adaptor plugs
-

- Wall plugs and screws
-



For your records

Date of purchase:
Place of purchase:
Serial number (on the underside of the telephone base unit):
Purchase price:

For warranty purposes, proof of purchase is required, so please keep your receipt.

Setting up

Follow these steps to get your Quartet 2010 ready for use.

Situating your Quartet 2010

Position your Quartet 2010 within 2 metres of a phone socket and 3 metres of a mains power socket.

Do not stand it on carpets or other similar surfaces which might generate fibres.

Do not cover or enclose the machine. Allow a free flow of air to its surfaces.

For the best performance do not position your Quartet 2010 close to other electrical equipment, eg. TV's or large metal objects, metal cabinets etc.

Your Quartet 2010 can be wall-mounted. For instructions on how to do this, see 'Wall-mounting' on page 39.

If you have any problems setting up or using your Quartet 2010, please call Helpline on **08457 697330**.

1 Plug your Quartet 2010 base unit into the telephone wall socket

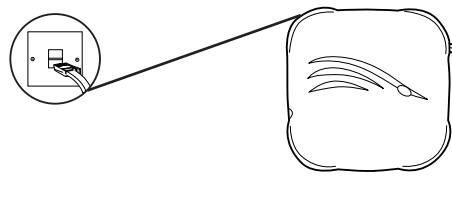

If you do not have a modern-style socket, call **Freefone 0800 800 150** and ask for a BT engineer to come and fit the correct type. This is a chargeable service.

2 Plug your Quartet 2010 base unit and charger into the mains power socket

There is one mains power adaptor for the charger and one for the base unit. Simply plug one end in the socket provided on the underside of each box, plug the other end into a mains power supply socket, and switch on.

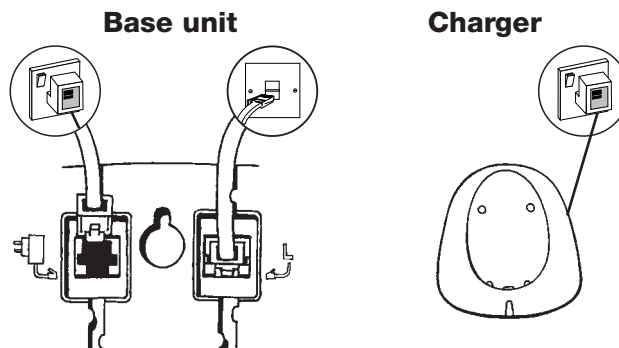

3 Charge the handset batteries for at least 24 hours

Before you use your Quartet 2010 for the first time, it is important to have the handset batteries fully charged. We recommend that you leave the Quartet 2010 handset on the cradle charger for at least 24 hours.

Battery Low Indication

When the batteries need re-charging, the display will show a 'battery low' symbol. Replace the handset on the charger to re-charge.

4 Aerial

It is advisable to extend the aerials on both the handset and base unit for optimum performance.

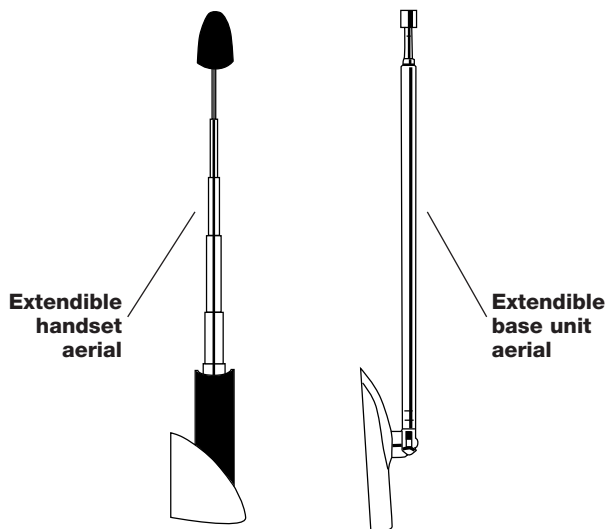

Your Quartet 2010 is now ready for use.

Using your Quartet 2010

Menu options

Your Quartet 2010 uses a display on the handset which allows you to select from the various product features detailed throughout this guide. Using the keypad, you are guided through the menu options by the prompts on the display.

At standby (that is the basic screen when not in use) the handset display shows:



Press the **Options** button. This opens the top level menu, showing the first of 2 main options. The first is:

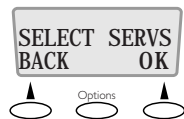

Press **Options** again. Display shows:



Each menu option offers you with a choice of prompts that appear on screen (ie. BACK, OK) which are selected using the 2 buttons located just below the display.

The Options button is in the middle of these.

For example, if you press **OK** when in SELECT SERVICES, you will be presented with a further menu of 7 screens, which you move between by pressing the **OPTIONS** button again.



Press **Options** button. Display shows:



Press **Options** button again. Display shows:

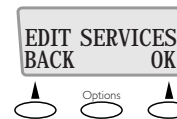
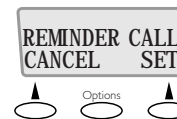
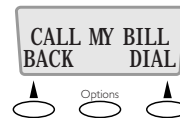

If you wish to select an option, press the right hand **OPTION** button, or **BACK** to move back to the previous menu.

When you wish to exit the menus completely, press and hold **BACK**.

The order of the select services will always start from the last service used.

Alternatively, if you press **OK** when in TELEPHONE, you will be presented with a further menu of 6 screens, which you also move between by pressing the **OPTIONS** button again.

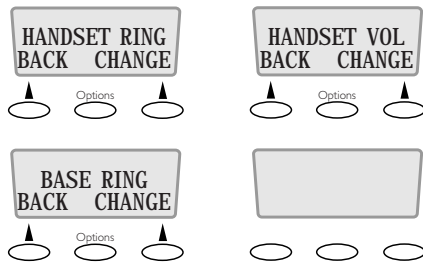

Display symbols

The following symbols may appear on your handset display.

When you have reached the feature you wish to select or change, just follow the on-screen menus.

Replacing the handset in the charger at any time will return the system to standby.

Using the menus you can edit and set up the Select Services you subscribe to, and the standard telephone settings.

MENU STRUCTURE (WHEN IN STANDBY)

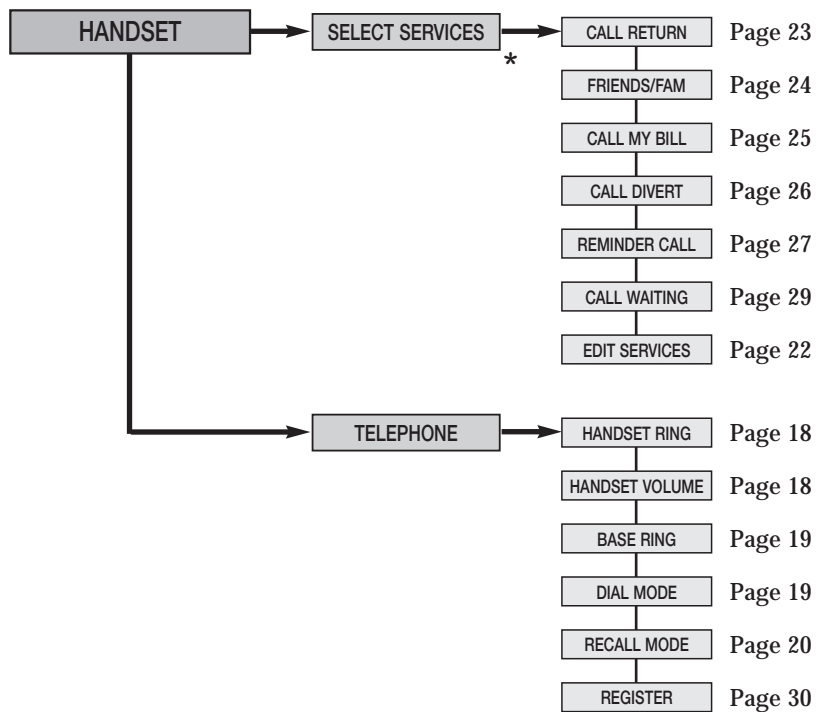

MENU STRUCTURE (DURING A CALL)

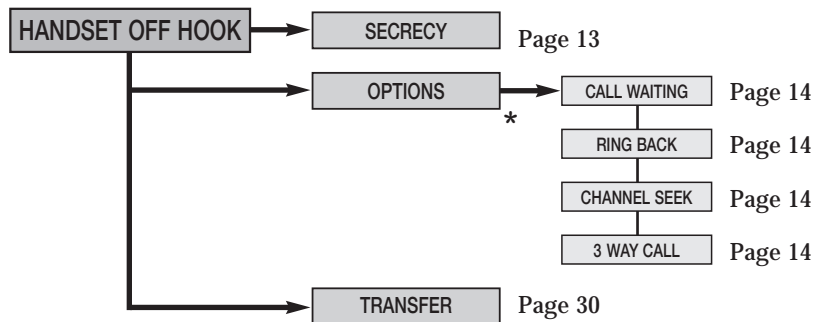

*The menu will begin from the last service used. This is designed to make the system easier to use.

DIAL

To make a call, you can choose to enter the number first, before you dial it.

Enter the number you wish to dial. The number will appear in handset display together with < for back and > for forward. The black cursor will flash.

<
>

To delete a digit press and release the button under the < symbol. Press the button under the > symbol to insert a space.

When you have entered the full number, press the **TALK** button. Your number will be dialled. (If you do not press the **TALK** button, you will be returned to

To end a call

Press buttons in order shown



Press the **TALK** button or replace the handset in its charger.

To redial the last number

Using the redial button that is located on the bottom left side of your handset:

Redial

Press the **REDIAL** button. The last number called appears in the display. This allows you to check it before dialling.



Press **TALK** to dial the call.

An alternative way of doing this is:



Redial

Press **TALK**, then the **REDIAL** button. The number is immediately dialled.

REDIAL will store the last 3 numbers called.

Redial

Press the **REDIAL** button until the number you wish to redial is displayed.



Press **TALK** to dial.

To receive a call

When the phone rings:

The light on the handset flashes.

Display shows CALL. This occurs both on and off the charger.

If the handset is in its charger:

Lift the handset and you are immediately in contact with the caller.



To end the call, press the **TALK** button or replace the handset in its charger.

If the handset is not in its charger:



Press the **TALK** button.

If another registered user picks up the call, an error tone sounds.



To end the call, press the **TALK** button or replace the handset in its charger.

To switch on the keyguard

You may like to lock your keypad when you are carrying it around. This stops you from accidentally dialling any numbers.



Press the left button (under the display) followed by the **★** button. Display shows KEYGUARD ON.



If you now try to dial, display will show KEYGUARD CANCEL. When you wish to cancel the keyguard, press the left button (under the display) followed by the **★** button.

Options during a call

You can use a number of additional functions during a call.

To adjust the handset earpiece volume (speech)

While on a call or listening to messages:

To adjust the volume of speech of the person you are talking to, press the **VOLUME** button situated at the top left-hand corner of the handset.

The volume will get louder or softer, depending on the start point, and will beep twice when it has reached either the highest or lowest volume setting. It will then go back the other way.

Press and release the volume button to increase/decrease for the required level.

To use the secrecy function

While on a call, if you wish to talk to someone close by without the person at the other end hearing the conversation, you can use the secrecy function.

During a call:

SEC Select the **SEC** option.
The display shows **SECURITY ON**.

This confirms that you have activated the secrecy function and you can now talk without the other person at the end of the line hearing you. You will also hear a beep every 5 seconds or so.

SEC To allow the caller to hear you again, select **SEC**. You can now resume your conversation.

To end the call and return to standby, press **TALK**.



Press buttons in order shown

For an explanation of Call Waiting service, please see page 22.

When you hear the Call Waiting beeps during a call:

Options



Press the **OPTIONS** button until the display shows CALL WAITING.

SWITCH

Press **SWITCH** to speak to the other caller. Your first call will be put 'on hold'.

SWITCH

Press **SWITCH** to toggle between the 2 callers.



When you wish to end one of the calls, press the **TALK** button. Your current call will end.



Your handset will ring, display showing CALL. Press the **TALK** button and you will be re-connected to the remaining caller. Press the **TALK** button again when you wish to end the call.

NOTE: Ring back service must be available – check with network provider.

Options



If the number you are calling is engaged, press the **OPTIONS** button until the display shows RING BACK.

OK

Press **OK**. The display shows PLEASE LISTEN and the voice says '*Your Ring Back request has been accepted*'.

To end the call, press the **TALK** button or replace the handset in its charger.

When the engaged number becomes free, your phone will ring and you will be connected to the person you were trying to contact. (They will answer the call as if you had just called them.)

Press the **OPTIONS** button until the display shows CHANNEL SEEK.

OK

Press

Using the Directory

Your Quartet 2010 can hold up to 20 names and numbers in its directory which will be stored in alphabetical order.

You can add names to the directory and edit or delete them as required.

You can also set up calls from entries in the directory.

To store an entry in the Directory

Press buttons in order shown



Press the **DIRECTORY** button. The display shows EMPTY or your first directory name.

NEW Select **NEW**. Display shows ENTER NAME.

KEYPAD Key the first letter of the name you wish to enter. (For instance, to display the letter C, press the **2** button until C appears on the display.)

You will now see the letter just entered, and the cursor will start flashing under the next letter space after a few seconds.

NOTE

If you want to enter 'C' followed by another 'C' wait for a few seconds for the cursor to automatically move onto the next space before entering the second 'C'.

>

Finish entering the letters of the name, using the > symbol to insert a space between the first and last name.

<

To delete a letter, use the < symbol.

SAVE

Press **SAVE**. The display shows ENTER NUMBER.

Enter the number in the same way as you entered the letters. If there are more than 12, they will be scrolled along, allowing the last 12 digits to be shown.

Insert a space if you wish (this is ignored during dialling).

To insert a pause in the string of digits (for instance for switchboard access), press the **REDIAL** button. The pause is shown as P.

Redial

SAVE

Press **SAVE**. Display shows UPDATING DIRECTORY followed by SAVED.

Display confirms name and number together for up to 15 seconds, then returns to standby.

BACK

Press and hold **BACK** to return to standby.

DIRECTORY FULL

If you try to store a new entry and you see the message DIRECTORY FULL, you will need to delete an entry before you can store any others. See 'to delete an entry in the directory' page 17.

AVAILABLE CHARACTERS

1 = & Õ () 1

2 = A B C 2

3 = D E F 3

4 = G H I 4

5 = J K L 5

6 = M N O 6

7 = P Q R S 7

8 = T U V 8

9 = W X Y Z 9

To add extra entries to the directory

Press buttons in order shown



Press the **DIRECTORY** button.

Options



Press the **OPTIONS** button.

NEW

Select **NEW**.

Follow the process on the previous page.

To edit an entry in the directory



Press the **DIRECTORY** button.



Use the **DIRECTORY** button to scroll through the names until the name you wish to edit appears.

Options



Press the **OPTIONS** button. The display shows the name.

EDIT

Press **EDIT**. You will now see the name, such as LOUISE DAVIES. Use the backspace, the forward space and the keypad to edit the name. Then press

SAVE

SAVE until a beep sounds.

SAVE

If it is only the number you wish to edit, press **SAVE** to confirm the name.

SAVE

Edit the number as before. Press **SAVE**. The revised name and number are displayed.

BACK

Press **BACK** to return to standby.

To view and then dial a call from the directory



Press the **DIRECTORY** button. The first stored name is displayed with the telephone number.



Press and release the **DIRECTORY** button to move to the next entry.

Or



Press and hold the **DIRECTORY** button to scroll through all entries. These are in alphabetical order. After reaching Z the scrolling takes you back to letter A.

If the number has more than 12 digits the display scrolls to the left.

Or



To go to a specific entry, use the **DIRECTORY** button then the handset keypad to enter the first letter of the name. For example, for "C Davis" press button **2** three times, for C, wait for the display to show the first directory entry under 'C', then press the directory button to access any further names under 'C'.



If there are no entries under a section beginning with the chosen letter, the display will move to the next section and letter.

To dial the number on the screen:



Press the **TALK** button. The name of the person will appear on the display for a few seconds before the call timing begins.

To delete an entry in the directory



Press the **DIRECTORY** button. The first entry appears on the display.



Use the **DIRECTORY** button to scroll through the names until the name you wish to delete appears.

Options



Press the **OPTIONS** button. The display shows the name.

DEL

Press **DEL**. The display shows DELETE?

YES

Press **YES**. After a few seconds you will hear a double beep and the display then shows UPDATING DIRECTORY then ENTRY DELETED.

After confirmation of the deletion has been displayed for one second, the next entry in the directory is displayed.

Optional settings

The following settings can be altered on your Quartet 2010.

To change the handset ringer melody

Press buttons in order shown

Options

Press the **OPTIONS** button until the display shows the TELEPHONE.

OK

Press **OK**. Display briefly shows MAKING LINK then HANDSET RING alternating with MELODY.

CHANGE

Press **CHANGE**. Display shows MELODY.

Options

Scroll through the options using the **OPTIONS** button. A different melody plays each time.

SAVE

Select one and press **SAVE**. Display returns to HANDSET RING alternating with the melody selected.

BACK

Press and hold **BACK** to return to standby.

To change the handset ringer volume

Options

Press the **OPTIONS** button until the display shows TELEPHONE.

OK

Press **OK**. The display briefly shows MAKING LINK then HANDSET RING.

Options

Press the **OPTIONS** button until the display shows HANDSET VOL alternating with VOLUME HIGH (LOW or OFF).

CHANGE

Press **CHANGE**. The display shows VOLUME HIGH (LOW or OFF).

Options

Scroll through the options using the **OPTIONS** button. You will hear the various volume options as well as see them on the display.

SAVE

Select one and press **SAVE**. The display returns to HANDSET VOL alternating with your selected volume level.

BACK

Press and hold **BACK** to return to standby.

To change the base unit ringer volume

Options

Press the **OPTIONS** button until the display shows TELEPHONE.

OK

Press **OK**. The display briefly shows MAKING LINK then HANDSET RING.

Options

Press the **OPTIONS** button until the display shows BASE RING alternating with VOLUME HIGH (LOW or OFF).

CHANGE

Press **CHANGE**. The display shows VOLUME HIGH (LOW or OFF).

Options

Scroll through the options using the **OPTIONS** button.

SAVE

Select one and press **SAVE**. A beep sounds. The display returns to BASE RING alternating with your selected volume levels.

BACK

Press and hold **BACK** to return to standby.

To change the dial mode

Options

Press the **OPTIONS** button until the display shows TELEPHONE.

OK

Press **OK**. The display briefly shows MAKING LINK then HANDSET RING.

Options

Press the **OPTIONS** button until the display shows DIAL MODE alternating with TONE.

CHANGE

Press **CHANGE**. The display shows TONE (or PULSE).

Options

Use the **OPTIONS** button to switch between the 2 settings.

SAVE

Select one and press **SAVE**. A beep sounds and the display returns to DIAL MODE alternating with your selected dial mode.

BACK

Press and hold **BACK** to return to standby.

To change recall mode

Press buttons in order shown

Options



Press the **OPTIONS** button until the display shows TELEPHONE.

OK

Press **OK**. The display briefly shows MAKING LINK then HANDSET RING.

Options



Press the **OPTIONS** button until the display shows RECALL MODE, alternating with TIMED BREAK (or EARTH).

CHANGE

Press **CHANGE**. The display shows TIMED BREAK (or EARTH).

Options



Use the **OPTIONS** button to switch between the 2 settings.

SAVE

Select one and press **SAVE**. A beep sounds. The display returns to RECALL MODE alternating with your selected recall mode.

BACK

Press and hold **BACK** to return to standby.

NOTE

It is recommended that on all BT lines, Dial Mode should be set to Tone. Recall mode to be set to Timed Break.

NOTE

Timed Break is required for use with Select Services.

Using Select Services

Your Quartet 2010 is designed to make it easy for you to access certain BT Select Services, Friends & Family and Call My Bill.

The available Select Services are Call Return, Call Diversion, Reminder Call, Call Waiting, Three Way Calling and Ring Back.

If you have any or all of these services (some do not require you to subscribe), your Quartet 2010 will help you to manage them from your handset using the *Select Services* menu.

When you start to use the *Select Services* menu, the handset will automatically take you to the last Select Service you accessed.

For information on BT Select Services, please call BT free on **0800 800 150** (residential) or **0800 800 152** (business)

PLEASE NOTE

If your Quartet 2010 is connected via a switchboard, the pre-programmed access to some Select Services will not be available but you can connect to the service by dialling your switchboard access code.

Please contact your switchboard provider if you are unsure.

Call Return

Using Call Return you can find out the number of the last person who called you and the date and time of the call by dialling **1471**. While on line you can return the call by dialling **3**.

Friends & Family

This is where the telephone number of the Friends & Family service is pre-programmed into your Quartet 2010, enabling you to dial the Friends & Family service and follow the instructions from the network to add or change numbers.

PLEASE NOTE

Before phoning the Friends & Family service, you need your BT customer number. This is in the top right-hand corner of your phone bill.

Call My Bill

This feature gives you the cost of calls recorded on your telephone number since your last bill. You can get an instant bill total including all charges up to the last working day.

PLEASE NOTE

Before phoning the Call My Bill service, you need your BT customer number. This is in the top right-hand corner of your phone bill.

Call Diversion

You can use your Quartet 2010 to request the network to divert all incoming calls to another number.

Using the Quartet 2010 you can only divert all calls.

Reminder Call

It is possible to select a Select Services option to ring you at a pre-set time, for instance, to remind you of an appointment.

Call Waiting

The Call Waiting service lets you know when you have another caller trying to contact you while you are already on the phone. You are alerted that a call is waiting by a series of on-the-line beeps.

Editing your Select Services

You may need to change some of your Select Services settings from time to time.

For example, Call Diversion has 3 optional access codes, **#21#**, **#61#** or **#67#**, each of which might be needed at different times. You may also want to change the divert number.

PLEASE NOTE

To make this type of change, you need to enter the Edit Services menu. Do not enter the Edit Select Services menu unless you are sure you wish to change your defaults.

3 Way Calling

You can hold a conversation with two other external callers. You can speak to both people at the same time or choose to switch between both callers.

VOICE PROMPTS

When using Select Services, your Quartet 2010 display may show 'Please listen' – listen to Select Service prompts which will guide you. Please refer to your Select Service instruction book for further details.

To make a Call Return call

Press buttons in order shown

Options



Press the **OPTIONS** button until the display shows SELECT SERVS.

OK

Press **OK**. The display shows the last Select Service accessed.

Options



Press the **OPTIONS** button until the display shows CALL RETURN.

Either



Press the **TALK** button. The display briefly shows MAKING LINK then PLEASE LISTEN. Follow the voice prompts.

Or

DIAL

Press **DIAL** and follow the voice prompts.

The CALL TIMER then replaces the number some seconds after the number has been dialled.



To end the call press **TALK**.

PLEASE NOTE

If you dial the number of the person who last called, you will be charged for this call

To edit Call Return

(Not to be edited unless requested by your Network Provider.)

Options



Press the **OPTIONS** button, the display shows SELECT SERVS.

OK

Press **OK**. The display shows the last Select Service accessed.

Options



Press the **OPTIONS** button until the display shows EDIT SERVS.

OK

Press **OK**.

Options



Press **OPTIONS** until the display shows CALL RETURN.

CHANGE

Select **CHANGE**. The display shows the current number the handset uses to access Call Return (1471).

< >

Using < > as required, edit the number displayed until it is the one you want, e.g. 1471.

SAVE

Press **SAVE**. The handset beeps and the display returns to CALL RETURN.

BACK

Press and hold **BACK** to return to standby.

To call Friends & Family

Press buttons in order shown

Options



Press the **OPTIONS** button. The display shows SELECT SERVS.

OK

Press **OK**. The display shows the last Select Service accessed.

Options



Press the **OPTIONS** button until the display shows FRIENDS/FAM.



Press the **TALK** button or **DIAL** button. The display briefly shows MAKING LINK then PLEASE LISTEN, the Friends & Family **0800** number is then shown. The call timer then replaces the number after a few seconds.

Follow the Friends & Family voice prompts.



To end the call, press the **TALK** button.

To set or edit Friends & Family

(Not to be edited unless requested by your Network Provider.)

Options



Press the **OPTIONS** button, the display shows SELECT SERVS.

OK

Press **OK**. The display shows the last Select Service accessed.

Options



Press the **OPTIONS** button until the display shows EDIT SERVS.

OK

Press **OK**.

Options



Press **OPTIONS** until the display shows FRIENDS/FAM.

CHANGE

Press **CHANGE**. The display shows the Friends & Family **0800** number. Edit the number if required, using the arrows to move the cursor over the digits.

< >

SAVE

Press **SAVE**. The display returns to FRIENDS/FAM.

BACK

Press and hold **BACK** to return to standby.

(Not to be edited unless requested by your Network Provider.)

Press the **OPTIONS** button. The display shows SELECT SERVS.

OK Press **OK**. The display shows the last Select Service accessed.

Press the **OPTIONS** button until the display shows EDIT SERVS.

OK Press **OK**.

Press the **OPTIONS** several times until the display shows CALL MY BILL.

CHANGE Select **CHANGE**. The display shows the current **0800** number for accessing Call My Bill. Edit the number if required, using the arrows to move the cursor over the digits.

SAVE When ready press **SAVE**. The display returns to CALL MY BILL.

BACK Press and hold **BACK** to return to standby.

To set your Call Diversion setting

Press buttons in order shown

Options



Press the **OPTIONS** button until the display shows SELECT SERVS.

OK

Press **OK**, then press the **OPTIONS** button until the display shows CALL DIVERT.

SET

Press **SET**. The display briefly shows MAKING LINK then PLEASE LISTEN. Follow the voice prompts.



To end the call press **TALK**.

To cancel your Call Diversion setting

Options



Press the **OPTIONS** button until the display shows SELECT SERVS.

OK

Press **OK**, then press the **OPTIONS** button until the display shows CALL DIVERT.

CANCEL

Press **CANCEL**. The display briefly shows MAKING LINK then PLEASE LISTEN. Follow the voice prompts.



To end the call press **TALK**.

To edit the Call Diversion set code

Options



Press the **OPTIONS** button, the display shows SELECT SERVS.

OK

Press **OK**. Display shows the last Select Service accessed.

Options



Press the **OPTIONS** button until the display shows EDIT SERVS.

OK

Press **OK**.

Options



Press the **OPTIONS** button until the display shows CALL DIVERT alternating with SET.

CHANGE

Press **CHANGE**.
Display shows the programmed code
★ 21★ for set.

Using the arrows as required enter or change the four-digit access number.

SAVE

Press **SAVE**. The display returns to CALL DIVERT alternating with SET.

BACK

Press and hold **BACK** to return to standby.

To edit the Call Diversion cancel code

Options

Press the **OPTIONS** button, the display shows SELECT SERVS.

OK

Press **OK**. Display shows the last Select Service accessed.

Options

Press the **OPTIONS** button until the display shows EDIT SERVS.

OK

Press **OK**.

Options

Press the **OPTIONS** button until the display shows CALL DIVERT alternating with CANCEL.

CHANGE

Press **CHANGE**.
Display shows the programmed code **#21#** for cancel.

Using the arrows as required enter or change the four-digit access number.

SAVE

Press **SAVE**. The display returns to CALL DIVERT alternating with SET or CANCEL.

BACK

Press and hold **BACK** to return to standby.

To edit the Reminder Call cancel code

Options

Press buttons in order shown

Press the **OPTIONS** button, the display shows SELECT SERVS.

OK

Press **OK**. The display shows the last Select Service accessed.

Options

Press the **OPTIONS** button until the display shows EDIT SERVS.

OK

Press **OK**.

Options

Press the **OPTIONS** button until the display shows REMINDER CALL alternating with SET or CANCEL.

CHANGE

Press **CHANGE**. The display shows **#55#**, the default setting.

KEYPAD

Using the numeric buttons as required enter the new code.

SAVE

Press **SAVE**. The display returns to REMINDER CALL. Your reminder call has been set.

BACK

Press and hold **BACK** to return to standby.

To edit or cancel the Reminder Call set up code

Press buttons in order shown

Options



Press the **OPTIONS** button, the display shows SELECT SERVS.

OK

Press **OK**. Display shows the last Select Service accessed.

Options



Press the **OPTIONS** button until the display shows EDIT SERVS.

OK

Press **OK**.

Options



Press the **OPTIONS** button until the display shows REMINDER CALL alternating with SET or CANCEL.

CHANGE

Press **CHANGE**. The display shows ★55★, as set previously.

KEYPAD

Using the numeric buttons as required enter the new code.

SAVE

Press **SAVE**. The display returns to REMINDER CALL. Your reminder call has been set.

BACK

Press and hold **BACK** to return to standby.

To turn your Reminder Call ON/OFF

Options



Press **OPTIONS** until the display shows SELECT SERVS.

OK

Press **OK**, then press **OPTIONS** until REMINDER CALL appears.

SET

Press **SET**. The display shows MAKING LINK, and then PLEASE LISTEN, then the number, then the time.

or

CANCEL

Press **CANCEL**. The display shows MAKING LINK and the REMINDER CALL.

The number is dialed.

The display shows PLEASE LISTEN. Follow the voice prompts.

The network voice confirms the setting or cancellation.



To end the call, press **TALK**.

To turn Call Waiting ON/OFF

Options



Press **OPTIONS** button until the display shows SELECT SERVS.

OK

Press **OK**. Press the **OPTIONS** button until the display shows CALL WAITING.

ON

Press **ON** or **OFF**. The display shows MAKING LINK followed by PLEASE LISTEN and your setting is confirmed by the voice.



To end the call press **TALK** or return the handset to the base unit.

To edit the Call Waiting code

(Not to be edited unless requested by your Network Provider.)

Options



Press the **OPTIONS** button. The display shows SELECT SERVS.

OK

Press **OK**. The display shows the last Select Service accessed.

Options



Press the **OPTIONS** button until the display shows EDIT SERVS.

OK

Press **OK**.

Options



Press the **OPTIONS** button until the display shows CALL WAITING alternating with ON.

Options



Press the **OPTIONS** button until the display shows CALL WAITING alternating with OFF.

CHANGE

Select **CHANGE**. The display shows the current setting, either **★43#** for ON or **#43#** for OFF.

<

Using the < as required to enter or edit the code as required.

SAVE

When ready press **SAVE**. The display returns to CALL WAITING alternating with your chosen setting.

BACK

Press and hold **BACK** to return to standby.

A double beep sounds and the display returns to standby. Your handset is now registered to the Quartet 2010 base unit.

You are Handset 1 and have taken an incoming call and wish to transfer it to another Quartet 2010 handset that is registered to your base unit.

During the call

TRANS Press **TRANS**. The display shows and TRANSFER X, where X is the number of one of the registered handsets.

KEYPAD Enter the number of the handset you wish to transfer the call to (**2, 3, 4**).

OK Press **OK**. The display shows HANDSET 1 and .

Press **TALK** or return the handset to the base unit. Your call has been transferred.

The display returns to standby.

If the call is not answered by the handset you have tried to transfer the call to after 30 seconds then the original handset will ring again.

To register your handset to another Quartet 2010 base

If you want to re-register the handset on another Quartet 2010 unit – then the handset needs to be completely reset. This is done by pressing the **VOLUME** button and the **REDIAL** button together until the display shows RESET.

VOL

Redial

OK Press **OK** to confirm.

You may then follow the instructions for registering an additional handset.

Charge the handset for 24 hours.
The handset display will show



YES Press **YES**. The display shows HANDSET X, with X flashing.

KEYPAD Enter the number of the handset to be registered. If yours is the second of two, enter **2**, if the first, enter **1** etc.

OK Press **OK**. The display reads PRESS BASE BUTTON.

Press the **BLACK** button on the base unit.

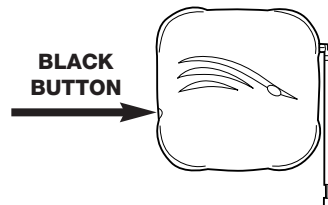

A double beep sounds and the display returns to standby. Your handset is now registered to the Quartet base unit.

NOTE

If the handset is reset the Directory memories will be erased and the handset options will return to their default settings.

Wall mounting

Your BT Quartet 2010 can be wall-mounted using the screws and wall plugs provided. Use the wall-mounting template opposite as a guide for the drill holes.

Before you wall-mount your Quartet 2010 or handset charger (or both), check that:

- The wall can support the weight of the apparatus.
- The position you choose leaves enough space for the unit to clear any obstruction on the wall with the aerial extended, such as a shelf.
- The positioning gives you sufficient radio coverage. Avoid mounting the units near large metal objects and minimising the amount of walls between the base unit and the handsets.

To wall-mount the Quartet 2010 base unit

- 1** Using a pencil, mark the place on the wall where you wish to place the screws using the wall-mounting template on page 39.
- 2** Drill two holes suitable for the screws and wall plugs supplied (if required).
- 3** Drive the screws into the wall, leaving about 5 mm free on which to hang the Quartet 2010.
- 4** Position the power and telephone cords down through the grooves before you hook the unit on the screws.

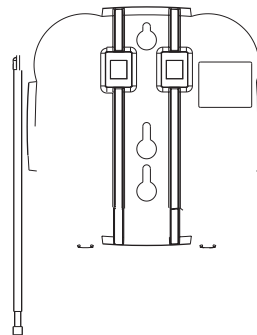

To wall-mount the handset charger

- 1 Using a pencil, mark two holes on the wall 48mm apart in the position you want to mount your charger.
- 2 Drill two holes with a drill bit suitable for the screws and wall-plugs supplied (if required).
- 3 Drive the screws into the wall, leaving about 9mm free on which to hang the charger.
- 4 Remove the back panel of your handset charger as shown.

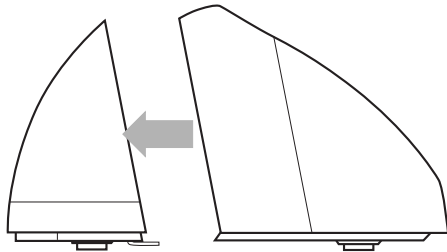

- 5 If you wish, you can rotate the back panel round and attach it to the bottom of the charger.

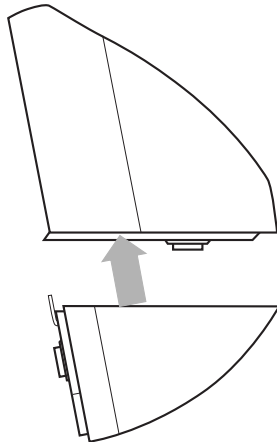

- 6 Press the power cord into its guide groove before you hook the unit on the screws.

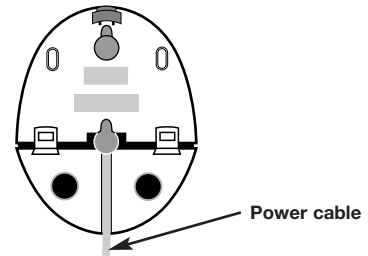

- 7 Hook the holes on the back of the charger over the screws heads in the wall.

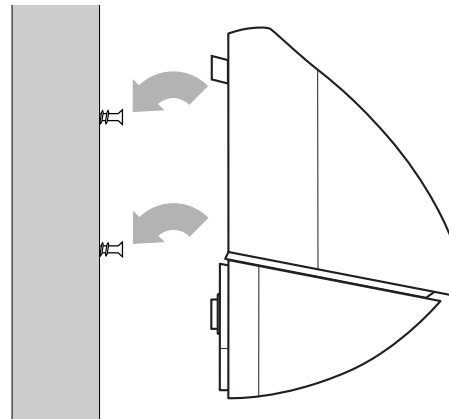

Help and advice

If you have any difficulty using your Quartet 2010, look in this section first for solutions to the most common problems

No dialling tone

Make sure the telephone lead is plugged into the telephone socket at the back of the Quartet 2010 and that the telephone lead is connected to your wall socket. Check that no other extension is in use.

Make sure that you are within range of the Quartet 2010 base unit. Move closer and try again.

Phone does not ring

Check that the handset ringer volume is not switched off.

Check that no other connected phones are off hook.

Check whether you have too many phone extensions in your home or office. For help with this, please refer to the section '*How many phones can you have?*' in Technical Advice on page 36.

BT can supply a REN booster to support up to 8 separate pieces of equipment connected to your line.

Cannot get through, even though dialling tone can be heard

You may be set to the wrong Dial Mode (Tone or Pulse). Check to see that it is correct for your use.

Batteries may be low, ensure that they are charged

Your handset may be out of range and you will need to move closer the the base unit.

Reception is poor during a call

You may need to change the channel. You can do this during the call.

Your handset may be out of range and you will need to move closer the the base unit.

Pre-programmed Select Services do not work

Dial the numbers below for further help.

BT Services Information

Freefone 0800 800 150 (*residential customers*).

Freefone 0800 800 152 (*business customers*).

BT Helpline 08457 697330

Please call the BT Helpline (local call rates) if you need further assistance with your BT Quartet 2010. Please have your Quartet 2010 Serial Number ready when calling the Helpline. For your convenience please enter the Serial Number, place and date of purchase on Page 5 of this user guide.

Emergency services

The emergency services can be contacted in the UK by dialling 999. You may also dial 112, which is valid in any country that is a member of the European Community.

In certain situations you may not be able to make an emergency call:

- If the telephone line is disconnected.
- If there is a line fault, whether on your phone or in the network.
- If there is a power failure.

If your BT Quartet 2010 is connected to a PBX (switchboard), you may have to dial an access number before entering 999 to contact the emergency services.

It is recommended that alternative arrangements are provided to enable you to make emergency calls during a mains power failure.

Safety instructions



Use only the power adaptor supplied and the handset battery pack supplied.



There is a slight chance that your phone could be damaged by an electrical storm. We recommend that you unplug your Quartet 2010 from the mains power and telephone line socket during storms.



The Quartet 2010 base unit, handset and charging units produce a small amount of heat during use. Therefore, we advise against placing these products on antique, veneered or wooden surfaces as damage may occur.



Do not use your Quartet 2010 in damp, humid conditions such as bathrooms.

Technical advice

Environment

Your BT Quartet 2010 should be kept free of dust, moisture, high temperature and vibration, and it should not be exposed to direct sunlight. It should not be used in bathrooms or near water.

Your Quartet 2010 is designed to be operated in a normal office or domestic environment only, where the relative humidity is no more than 60%.

Maintaining your Quartet 2010

Clean with a soft, dry cloth, do not use a damp cloth.

Do not use abrasive materials, solvents or aerosol cleaners as these may damage the unit. Do not place on untreated antique furniture.

How many phones can you have?

Although you may have any number of sockets, it is important to limit the number of phones and other pieces of apparatus connected in order to ensure that each phone will ring.

All telephone equipment has a Ringer Equivalence Number (REN), which is used to calculate how many pieces of apparatus may be connected to any one telephone line.

Telephones provided by BT have a REN of 1, unless otherwise stated on the underside of the phone. Even where the number of telephones has been limited, there is no guarantee that different types of phone on the same line will ring, even when the REN is less than 4.

You must not connect more than 4 products to a single line.

A Quartet 2010 with 4 additional handsets, has a REN value of 1.

Network connection information

Your Quartet 2010 is designed to work with both BT and other UK networks, including cable.

Although this equipment can use either Loop Disconnect (Pulse) or DTMF (Tone) signalling, the performance of the DTMF (Tone) signalling is subject to regulatory requirements for correct operation. It is therefore strongly recommended that your equipment is set to use DTMF (Tone) signalling for access to public or private emergency services.

DTMF signalling also provides faster call set-up.

Advice on connection to BT systems can be obtained by dialling BT **Freefone 0800 800 152**.

Guarantee

If you own your BT Quartet 2010 and it is under BT's guarantee, BT guarantees the product for one year, provided that:

The goods have only been used for their intended purpose, and have not been subjected to misuse or been wilfully or accidentally damaged.

The goods have not been tampered with or repaired by anyone other than BT, its staff or its agents.

If a fault does occur, and you bought the unit yourself, it will be repaired or replaced free of charge, provided you return it to where you purchased it and produce your receipt.

The terms and conditions of this guarantee do not affect your statutory rights.

If you own your BT Quartet 2010, but the guarantee period has expired:

If your BT Quartet 2010 needs repair after the guarantee period has ended, it must be repaired so as to remain compliant with the approval requirements for connection to the telephone network.

For details of BT's recommended repair agents, please call BT free of charge on **Freefone 0800 800 150**, or visit your nearest BT shop.

Index

Additional handsets	30	Mains power socket	6	Viewing an entry	17
Aerial	7	Maintenance	36	Volume, handset	14
		Making calls	11		
BT Services Information	34	Menu options	8	Wall Mounting	32
		Menu structure	10	Template	39
Call Diversion	26	Optional Settings	18		
Call My Bill	25				
Call Return	23	Recall mode	20		
Call Waiting	14, 29	Receiving calls	12		
Channel seeker	14	Redialling the last number	12		
Charging handset batteries	7	Registering	30		
		base unit	31		
Delete an entry	17	Reminder Call	27		
Dial mode	19	Ring back	14		
Directory	15	Ringer Equivalence Number			
		(REN)	36		
Edit an entry	16	Ringer melody	18		
Emergency Services	35	Safety Instructions	35		
Ending calls	12	Secrecy	13		
Environment	36	Select Services	21		
		Setting up	6		
Friends & Family	24	Store an entry	15		
		Symbols	9		
Guarantee	37				
		Technical Advice	36		
Help and Advice	34	Telephone wall socket	6		
Helpline	35	Three way calling	14		
		To view a number			
		before dialling	11		
Keypad guard	12	Transfer calls	30		

Wall mounting Template

Base station

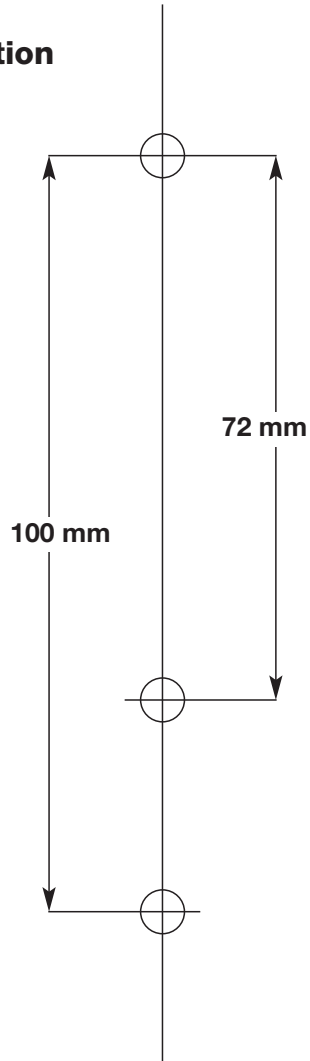

Handset charger

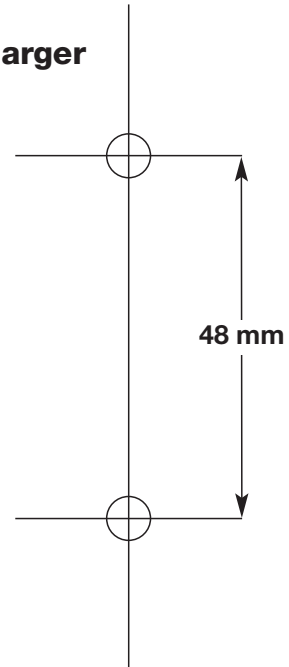



*Offices in Europe, North America,
Japan and Asia Pacific.*

The telecommunications services described in this publication are subject to availability and may be modified from time to time. Services and equipment are provided subject to British Telecommunications plc's respective standard conditions of contract. Nothing in this publication forms any part of any contract.

Touchtone™ is a registered trade mark of British Telecommunications plc in the UK.

© British Telecommunications plc 1998.
Registered Office: 81 Newgate Street, London EC1A 7AJ.
Registered in England No. 1800000.
Printed in Thailand. Quartet 2010 Issue 1 (11/98) 5
Designed by The Art & Design Partnership Limited.



CE compliant to 89/336/EEC
(EMC Directive) & 73/23/EEC
(Low Voltage Directive)

